

VICINITY MAP

SITE DATA TABLE	
GENERAL DESIGN DATA	
PARCEL NUMBERS	35284.4022, .4023, .4024, .4025, .4026, .4027, .4028, .4029
EXISTING ZONING	RSF
LANDUSE	RESIDENTIAL 4-10
PROJECT AREA (ac)	3.76
TOTAL LOT AREA (ac)	3.34
RIGHT OF WAY AREA (ac)	0.42
NUMBER OF LOTS	13
TOTAL TRACT AREA (ac)	0.00
MAXIMUM LOT AREA (ac)	0.45
MINIMUM LOT AREA (ac)	0.16
PROPERTY DENSITY (lots/ac)	3.46
AVERAGE LOT AREA (ac)	0.26
DOMESTIC WATER	CITY OF SPOKANE
SANITARY SEWER DISPOSAL	CITY OF SPOKANE
FIRE DEPARTMENT	CITY OF SPOKANE
DATUM	NAVD-88
PUBLIC ROAD AREA	- SF
ELECTRIC PROVIDER	AVISTA
GAS PROVIDER	AVISTA
OTHER PURVEYORS	TO BE DETERMINED

LEGEND

	NEW PL
	EX. PL

Line Table (L)

Line #	Length	Direction
L1	138.30	S89° 52' 24"W
L2	16.15	N0° 03' 00"E
L3	168.95	N0° 03' 00"E
L4	65.00	N0° 03' 00"E

Line Table (L)

Line #	Length	Direction
L5*	233.94	N0° 03' 00"E

*L5=L3+L4

Curve Table (C)

Curve #	Length	Radius	Delta
C1	53.42	59.11	51.78
C2*	91.45	103.00	50.87
C3*	91.45	103.00	50.87

*C2=C3

PARCEL LEGAL DESCRIPTION

FOUND IN SCOUT ASSESSORS INFORMATION

35284.4022
 WATERFORD AT GRAPETREE (AFN 5471328) LT 22 BLK 1
 .4023
 WATERFORD AT GRAPETREE (AFN 5471328) LT 23 BLK 1
 .4024
 WATERFORD AT GRAPETREE (AFN 5471328) LT 24 BLK 1
 .4025
 WATERFORD AT GRAPETREE (AFN 5471328) LT 25 BLK 1
 .4026
 WATERFORD AT GRAPETREE (AFN 5471328) LT 26 BLK 1
 .4027
 WATERFORD AT GRAPETREE (AFN 5471328) LT 27 BLK 1
 .4028
 WATERFORD AT GRAPETREE (AFN 5471328) LT 28 BLK 1
 .4029
 WATERFORD AT GRAPETREE (AFN 5471328) LT 29 BLK 1

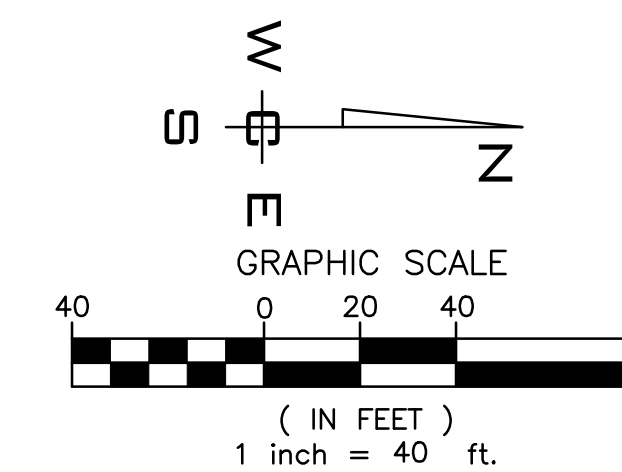

ENGINEER/CONTACT
 WHIPPLE CONSULTING ENGINEERS
 21 S. PINES ROAD
 SPOKANE VALLEY, WA 99216
 PHONE: 509-893-2617
 CONTACT: TODD R WHIPPLE, P.E.
 TODD@WHIPPLECE.COM

PROPERTY OWNER
 APPLETREE COURT CT.
 PO BOX 141749
 SPOKANE WA 99214.1749

*NOTE: Areas which have parking shall be 9.0' wide with gutter along normal curb line and parking area will rise with 2.0% grade

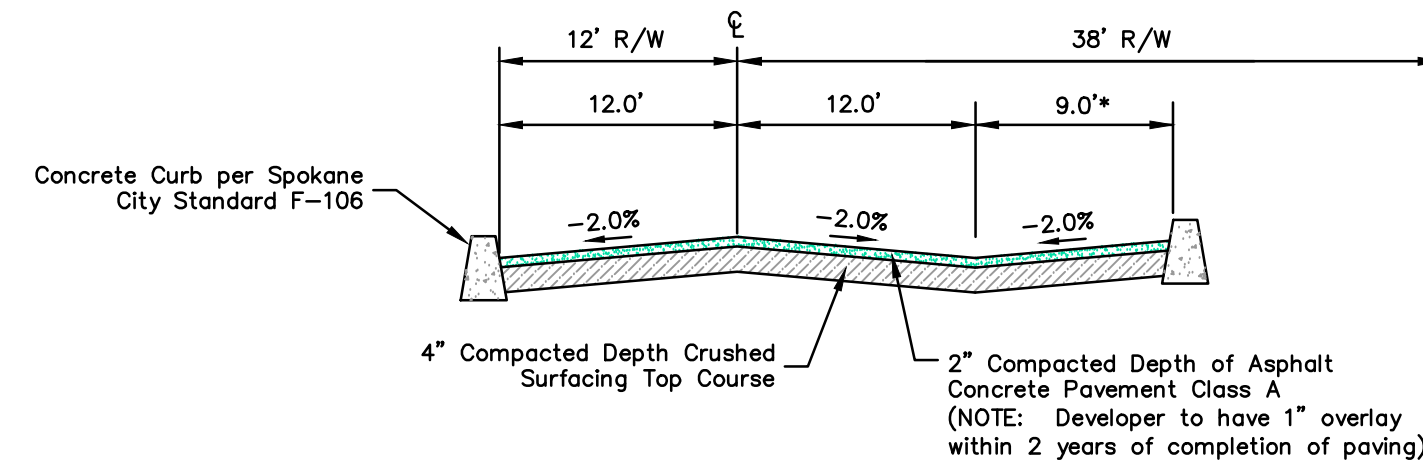

TYPICAL ROADWAY SECTION
 APPLETREE COURT
 (not to scale)

PLAN SHOWING RE-PLAT OVERLAYING ORIGINAL PLAT

SCALE: 1"=40'

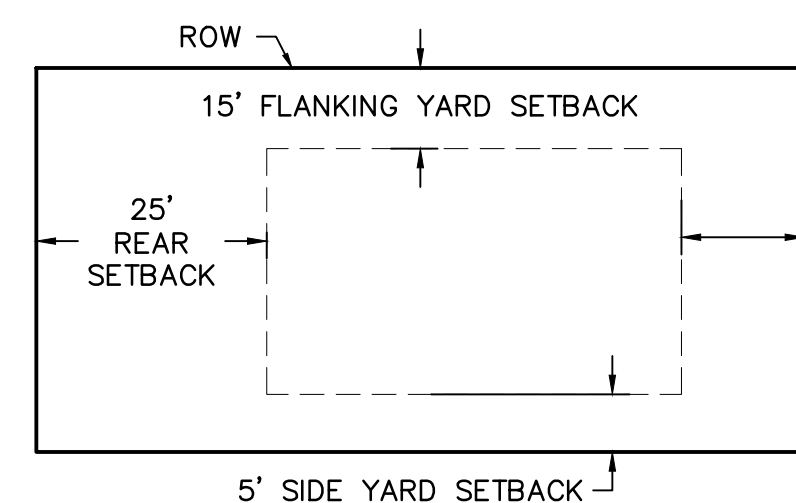

TYPICAL LOT SETBACK DETAIL
 NOT TO SCALE

NO.	DATE	BY	REVISIONS

SCALE:
HORIZONTAL:
 1"=40'
VERTICAL:

PROJ #: 15-1439
DATE: 10/10/18
DRAWN: JPP
REVIEWED: TRW

<input type="checkbox"/>	CIVIL
<input type="checkbox"/>	STRUCTURAL
<input type="checkbox"/>	SURVEYING
<input type="checkbox"/>	TRAFFIC
<input checked="" type="checkbox"/>	PLANNING
<input type="checkbox"/>	LANDSCAPE
<input type="checkbox"/>	OTHER



WATERFORD AT GRAPETREE
RE-PLAT
2423 S. APPLETREE CT.
SPOKANE, WA



SHEET
1 OF 1
JOB NUMBER
15-1439