



May 2024

Version 1

# City of Spokane Bicycle Parking Guidelines



Request a Bicycle Rack .....	3
Overview .....	4
Bike Parking Rates .....	5-7
Bicycle Rack Design Requirements .....	8-9
Bike Corrals.....	10
Installation Considerations.....	11
Short Term Bicycle Parking.....	12
Long Term Bicycle Parking.....	14
Recommended Bike Parking Models.....	20

## Request a bike rack!

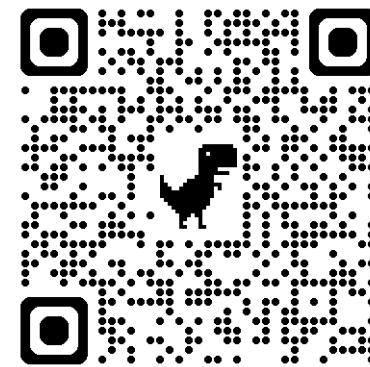

Scan Here

The City of Spokane's Planning and Economic Development Bike Rack Program provides a free bike racks for installation in the public right-of-way near businesses and commercial areas. These bike racks are intended for public bike and scooter parking throughout Spokane.

## Who can request one?

Residents and business owners in Spokane can request a bike rack.

## Why should you request a bike rack?

The City of Spokane supports bicycling as an efficient transportation option. More people now bicycle for commuting, shopping, and general transportation. Providing bicycle parking encourages people to bicycle: when people are confident in finding convenient and secure parking at their destination, they bicycle more often.

## Where can they be installed?

These bike racks/corrals will be installed on public sidewalks and in the public right-of-way. A bike rack requested through the City's Bike Rack Program will be installed by the City in order to ensure proper siting, permissions and installation.

## How much do they cost?

Nothing! The City of Spokane's shared mobility program for e-scooters and e-bikes, operated by Lime, funds these bike racks in order to support safe and secure parking options in accessible locations.

To learn more go to our website at:

<https://my.spokanecity.org/projects/bike-rack-program/>

Request a Bike Corral here:

<https://spokanecity.wufoo.com/forms/bike-rack-request/>

# Overview



Our Comprehensive Plan envisions Spokane as a place where riding a bicycle is a comfortable and integral part of daily life for people of all ages and abilities. Achieving this vision requires the provision of safe, reliable, and secure bicycle parking throughout the community. The guidance in this document ensures that bicycle parking facilities installed in Spokane meet city code, follow best practices, and, most importantly, address the practical needs of people bicycling for everyday transportation

## Purpose

Following the guidance in this document ensures that bicycle racks are safe, easy to use, and accessible. Errors in the selection or installation of bicycle parking infrastructure can unintentionally make racks unusable or dangerous, decreasing the viability of bicycling as a transportation option.

## Applicability

Standards in this guide follow Spokane Municipal Code (SMC) section 17C.230.200. When the use of an existing building changes, bicycle parking shall be provided to meet the standards established by this code, except where the new number is within 10% of the existing number of spaces. When conducting additions, alterations, increases in floor area of bicycle parking requirements by addition or alteration, the required number of bicycle parking spaces as required for the increase shall be provided.

For the full criteria, visit the [Spokane Municipal Code website](#).



This page intentionally left blank

# Bike Parking Rates

Every building in the City of Spokane should include bike parking at the rates detailed below. These rates can be found in the Spokane Municipal Code under Section 17C.230.200 Bicycle Parking.

	Building Use	Required Short-term Parking [3]	Required Long-term Parking
<b>Residential</b>	Group Living	0	1 per 10 residents
	Multifamily dwellings (ten or more units)	0	0.5 per unit
<b>Commercial</b>	Adult Business	1 per 5,000 sq. ft. of floor area	None below 12,000 sq. ft. of floor area; and then 1 per 12,000 sq. ft. of floor area
	Commercial Outdoor Recreation	1 per 5,000 sq. ft. of floor area	None below 12,000 sq. ft. of floor area; and then 1 per 12,000 sq. ft. of floor area
	Commercial Parking	None	None
	Drive-through Facility	None	None
	Major Event Entertainment	1 per 60 seats	None below 24,000 sq. ft. of floor area; and then 1 per 24,000 sq. ft. of floor area
	General Office & Medical & Dental	1 per 20,000 sq. ft. of floor area	None below 10,000 sq. ft. of floor area; and then 1 per 10,000 sq. ft. of floor area
	Quick Vehicle Servicing	1 per 20,000 sq. ft. of floor area	None below 12,000 sq. ft. of floor area; and then 1 per 12,000 sq. ft. of floor area
	Retail Sales & Service *	1 per 5,000 sq. ft. of floor area	None below 12,000 sq. ft. of floor area; and then 1 per 12,000 sq. ft. of floor area
	Temporary Lodging	1 per 30 rent-able rooms	None below 30 rent-able rooms; and then 1 per 30 rent-able rooms
	Theaters	1 per 30 seats	None below 12,000 sq. ft. of floor area; and then 1 per 12,000 sq. ft.
	Mini-storage Facilities	2 per development	None
	Vehicle Repair	1 per 20,000 sq. ft. of floor area	None below 12,000 sq. ft. of floor area; and then 1 per 12,000 sq. ft. of floor area

\* Includes: Retail, Personal Service, Repair-oriented, Restaurants and Bars, Health Clubs, Gyms, Lodges, Meeting Rooms and similar continuous entertainment, such as Arcades and Bowling Alleys, Retail sales and services of large items, such as appliances, furniture and equipment

[3] Baseline parking is 2 spots. SMC 17C.230.200(C)(1) Bicycle racks designed to accommodate two bicycles, such as an inverted-u rack, are considered two (2) bicycle parking spaces.

This page intentionally left blank

# Bike Parking Rates

	Building Use	Required Short-term Parking [3]	Required Long-term Parking
INDUSTRIAL	Industrial Services, Railroad Yards, Wholesale Sales	None	None below 20,000 sq. ft. of floor area; and then 1 per 20,000 sq. ft. of floor area
	Manufacturing and Production	None	None below 20,000 sq. ft. of floor area; and then 1 per 20,000 sq. ft. of floor area
	Warehouse and Freight Movement	None	None below 20,000 sq. ft. of floor area; and then 1 per 20,000 sq. ft. of floor area
	Waste-related	None	None below 20,000 sq. ft. of floor area; and then 1 per 20,000 sq. ft. of floor area
INSTITUTIONAL	Basic Utilities	1 per 20 vehicle spaces (whether vehicle parking is required by code or not)	None below 20 vehicle spaces; and then 1 per 20 vehicle spaces (whether vehicle parking is required by code or not)
	Colleges	1 per 20,000 sq. ft. of floor area associated with each building	None below 30 staff/faculty; and then 1 per 30 staff/faculty
	Community Service	1 per 5,000 sq. ft. of floor area	None below 12,000 sq. ft. of floor area; and then 1 per 12,000 sq. ft. of floor area
	Daycare	1 per 5,000 sq. ft. of floor area	None below 12,000 sq. ft. of floor area; and then 1 per 12,000 sq. ft. of floor area
	Medical Centers	1 per 20,000 sq. ft. of floor area	None below 12,000 sq. ft. of floor area; and then 1 per 12,000 sq. ft. of floor area
	Parks and Open Areas[1] [2]	1-3 amenities= 4 spaces 4-7 amenities= 8 spaces 7-12 amenities= 16 spaces 12+ amenities= 24 spaces Additionally: 1 per 10 vehicle spaces (whether vehicle parking is required by code or not)	None

# Bike Parking Rates

	Building Use	Required Short-term Parking [3]	Required Long-term Parking
INSTITUTIONAL	Religious Institutions	1 per 20,000 sq. ft. of floor area	None below 12,000 sq. ft. of floor area; and then 1 per 12,000 sq. ft. of floor area
	Schools: Grade, Elementary, Junior High	1 per classroom	None
OTHER	Agriculture	None	None
	Aviation and Surface Passenger Terminals	None	None
	Detention Facilities	None	None
	Essential Public Facilities	None	None
	Wireless Communication Facilities Rail Lines and Utility Corridors	None	None

[1] Parks and Open Space amenities, for the purpose of this section, are defined as park facilities such as playgrounds, ball fields, and splash pads. These do not include any natural area amenities such as habitat viewing station.

[2] Bicycle rack requirements based on amenities should be located near the amenities the racks are intended to serve

[3] Baseline parking is 2 spots. SMC 17C.230.200(C)(1) Bicycle racks designed to accommodate two bicycles, such as an inverted-u rack, are considered two (2) bicycle parking spaces.



# Bicycle Rack Design Requirements



Figure 1 - Rack design requirements

## Design Requirements

The following design features ensure the quality and usability of bicycle racks in Spokane.

Each bike rack must:

- ◆ Provide two points of contact between the bicycle and the rack.
- ◆ Allow for the frame and both wheels to be locked with a U-lock.
- ◆ Have a galvanized steel or stainless steel with powder-coating. This will make it theft resistant, and will also wear in an aesthetically pleasing manner.
- ◆ Not require the bike to be lifted.

## Inverted-U Racks

The Inverted-U Racks are simple, accommodate a variety of locks, and meet the above key design features.

This rack is the City's standard. The standard measurement are shown below in Figure 2. It can be used as a single stand-alone or as a corral, linked by parallel rails.

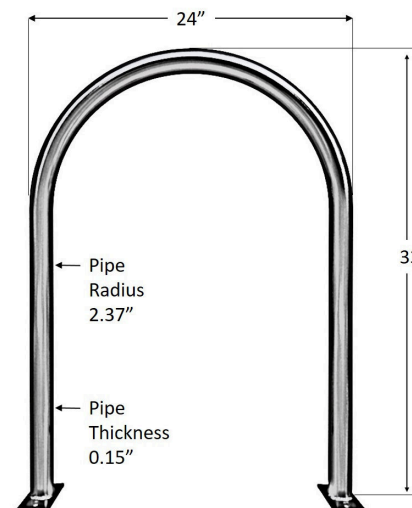

Figure 2 - Inverted U-rack dimensions

Please visit the link below to make a bike rack request for your business.

[Request a bike rack HERE](#)

## Examples of allowed and not allowed designs

Examples of bicycle racks that **do not** meet the design requirements:



Examples of bicycle racks that **do** meet the design requirements:

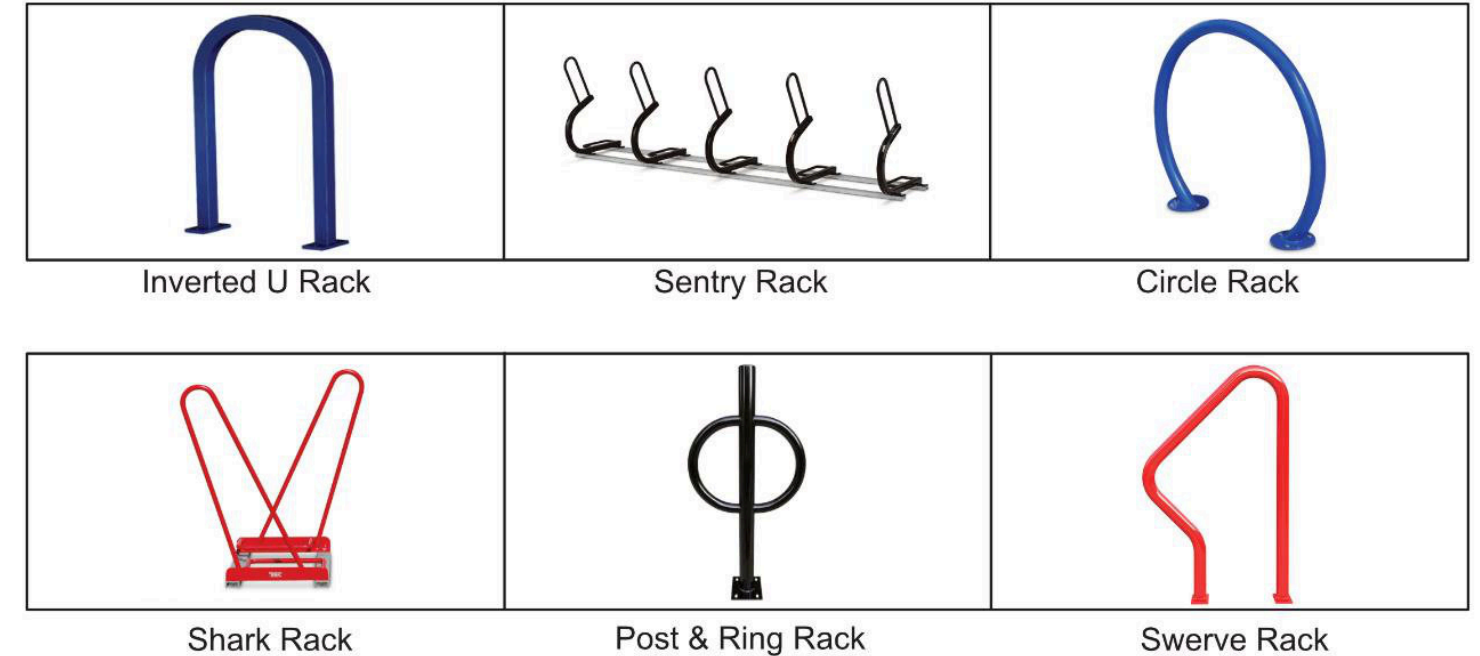

Figure 3- Allowed and not allowed bicycle rack types

For example makes and models of qualifying bike racks, please see [page 22](#).



# Bike Corrals

# Installation Considerations

## Bike Corral Spacing Requirements

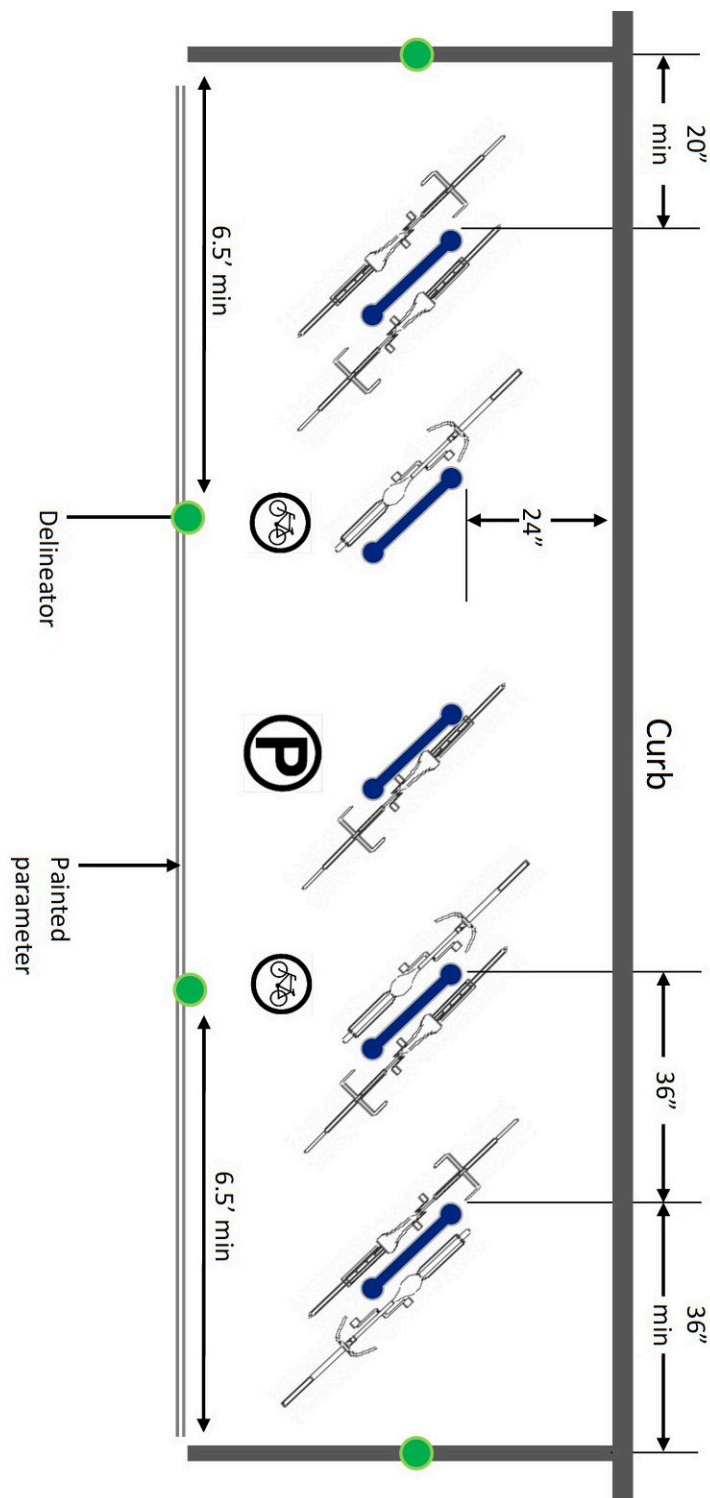

Bike Corrals are high-volume bike parking areas placed in the street in a parking stall or other available area within the public right-of-way. Bike Corrals are installed by the City of Spokane at locations with a high volume of bicycle trips. Bike Corrals can also be requested by individual businesses or property owners who desire to provide a high volume of bike parking near their location.

Bike Corrals consist of 3 to 6 inverted-U bike racks, accommodating 6-12 bicycles within a single car parking spot. Multiple Bike Corrals can be installed in adjoining spaces to offer even higher quantities of bike parking.

Components of a Bike Corral include:

- ◆ Three or more inverted-U bike racks
- ◆ Painted perimeter on the pavement
- ◆ Painted bike parking stencils to identify the purpose of the space
- ◆ Optional rubber curbs to prevent accidental damage to the bike racks by parked cars



**Request a bike rack [HERE](#).**

When installing a Bike Rack, please follow the spacing guidance included in this document on [page 15](#).

In downtown Spokane, numerous sidewalks are vaulted and have electric wiring, utilities, and usable building space directly under the sidewalk. It is important to contact the City of Spokane prior to installation of a downtown bike rack.



Image source: City of Spokane



Image source: City of Spokane



# Short Term Bicycle Parking

## Group Parking

Property owners & businesses located on the same side of the street and on the same block may establish a grouped short-term bicycle parking area that is consistent with SMC Section 17C.230.200 C.5

Short-term bicycle parking accommodates people parking their bikes for short periods, generally two hours or less. Typically, racks are placed in the public right-of-way, on sidewalks near the buildings they serve, or in the street near on-street vehicle parking areas.

## Placing a Short-Term Bike Rack

- ◆ Bike racks should be visible to people occupying the building and general passersby to reduce theft and increase comfort and security for people using the racks.
- ◆ Bike racks must be placed within 50 feet of the main entrance to the building to increase security and make bicycle travel convenient.
- ◆ Bike racks must be outside the building.
- ◆ Bike racks should fit entirely within the sidewalk's pedestrian buffer strip.
- ◆ Bike racks should be placed between parking stalls to avoid conflicts with opening car doors.
- ◆ Bike racks should be placed on paved surfaces or other surfaces that are stable, firm and slip-resistant consistent with ADA requirements.

## Avoid

- ◆ Bike racks cannot be installed adjacent to disabled parking zones.
- ◆ Bike racks should not be directly placed in front of windows and doors that would act as a fire escape.

**The bike rack pictured on the left is placed too closely to the building, allowing only one bike to use the rack at a time.**

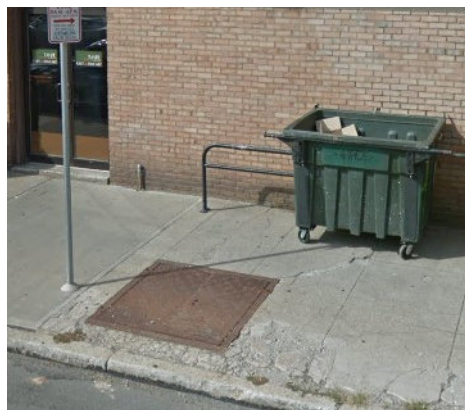

Figure 4: Improperly placed bike rack.

# Short-term parking

## Required Spacing

### On sidewalk, parallel to curb

- ◆ Must have a minimum sidewalk width of 9 feet.
- ◆ Must have a distance of at least 2 feet from the curb to prevent impacts from car door opening, 3 feet is recommended.
- ◆ Must have a minimum distance of 6 feet between the bicycle rack and the property line/building.
- ◆ Must be at least 15 feet from any fire hydrant.
- ◆ Must be located at a minimum of 5 feet from obstructions such as street trees, utilities, and street furniture.
- ◆ Must be at least 5 feet from loading/unloading zone at a bus stop.
- ◆ Recommended distance between multiple racks, end-to-end, is 6 feet.

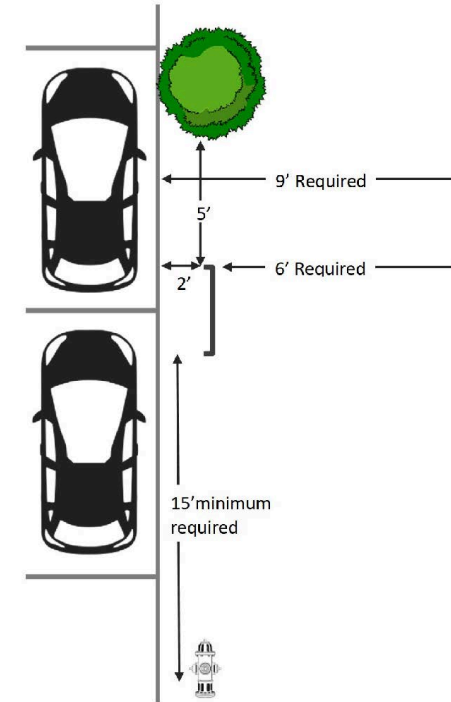

### On sidewalk, perpendicular to curb

- ◆ Must have a minimum sidewalk width of 15 feet.
- ◆ Must have a distance of at least 2 feet from the curb, 3 feet is recommended.
- ◆ Must have a minimum of 10 feet between the bicycle rack and the property line/building.
- ◆ Must be at least 5 from any fire hydrant.
- ◆ Must be located at a minimum of 5 feet from obstructions such as street trees, utilities, and street furniture.
- ◆ Must be at least 5 feet from any bus loading/unloading area.
- ◆ Recommended distance between multiple racks, side-by-side, is 3 feet.

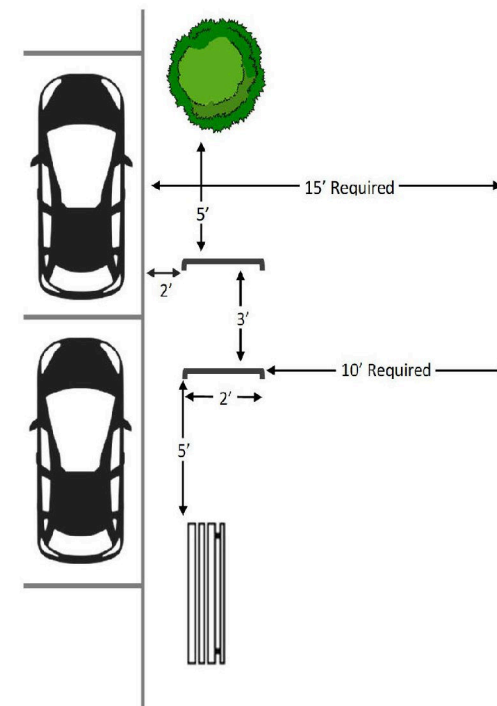



# Long Term Bicycle Parking



Source: [bikecoloradosprings.org](http://bikecoloradosprings.org)

Long-term bicycle parking provides employees, students, residents, commuters, and others who generally stay at a site for several hours with a secure and weather-protected place to park bicycles.

## Long-term parking must be located:

- ◆ Within a building, or
- ◆ On-Site, including parking structures and garages, or
- ◆ Within three hundred feet of the site.

## Additional Requirements

- ◆ Long-term bicycle parking must be provided in racks or bike lockers.
- ◆ At least twenty-five percent (25%) of the racks must be horizontal to accommodate those who cannot lift a bicycle into a vertical position and cargo, tandem, long-tailed or similar bicycles that do not fit into vertical racks.
- ◆ A garage dedicated exclusively to a residential unit may fulfill the requirements for one (1) long-term bicycle parking space.

## Security Requirements:

- ◆ To provide security, long-term bicycle parking must be:
- ◆ In a locked room; or
- ◆ In an enclosure with a locked gate or door. The walls of the enclosure are to be at least 8 feet tall or be floor-to ceiling; or
- ◆ In a permanently anchored, enclosed, and secured bike locker.
- ◆ To protect bicycles from the elements, long-term bicycle parking must be covered.
- ◆ The cover must be permanent and impervious
- ◆ Long-term bicycle parking shall be placed on floor and ground surfaces that are stable, firm, and slip-resistant consistent with ADA requirements.

# Long-term parking

- ◆ Residential in-unit long-term bicycle parking can be provided, but does not count towards fulfilling the long-term bicycle parking requirements.
- ◆ Long-term bike storage design details must be provided with site layouts to determine the number of bicycle parking spaces.

## Grouped Bicycle Parking Areas

Property owners and businesses located on the same block may establish a grouped bicycle parking area where long-term bicycle parking solutions may be implemented.

- ◆ These areas shall be located no further than 300 feet from each site they intend to serve.
- ◆ Bicycle parking shall be at a location that can be reached by an accessible route.
- ◆ Bicycle parking shall meet all other relevant standards of this section.



Image Source: [The League of American Bicyclists](http://The League of American Bicyclists)

# Long-term parking

## Horizontal Spacing

For horizontal racks such as the inverted-u rack, long-term bicycle parking spacing is as follows and shown in Figure 9:

- ◆ A minimum of 3 feet parallel spacing between each rack; and
- ◆ A minimum of 5 feet perpendicular access aisle between rows of bicycle parking; and
- ◆ A minimum of 2 feet 6 inches of perpendicular spacing between bicycle racks and walls or obstructions; and
- ◆ A minimum of 2 feet for user access between a wall or other obstruction and the side of the nearest parked bicycle

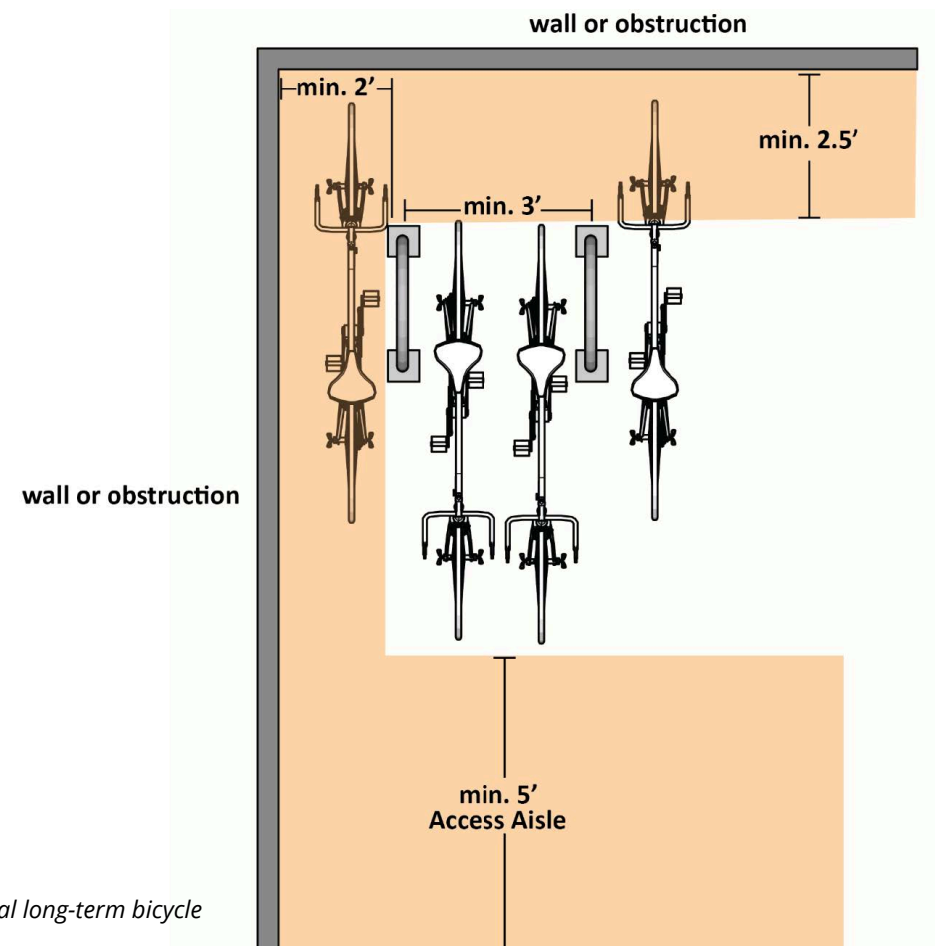

Figure 9 - Spacing requirements for horizontal long-term bicycle racks

## Vertical Spacing

For vertical wall-mounted racks, long-term bicycle parking must adhere to the following spacing requirements below and shown in Figures 11 and 12:

- ◆ A minimum of 3 feet parallel spacing between each rack; or,
- ◆ A minimum of 1 foot 6 inches parallel spacing combined with a minimum of 8 inch vertical off-set between each rack; and
- ◆ A minimum of 5 feet perpendicular access aisle between rows of bicycle parking, and
- ◆ A minimum of 1 foot 6 inches for user access between a wall or other obstruction and the side of the nearest parked bicycle.

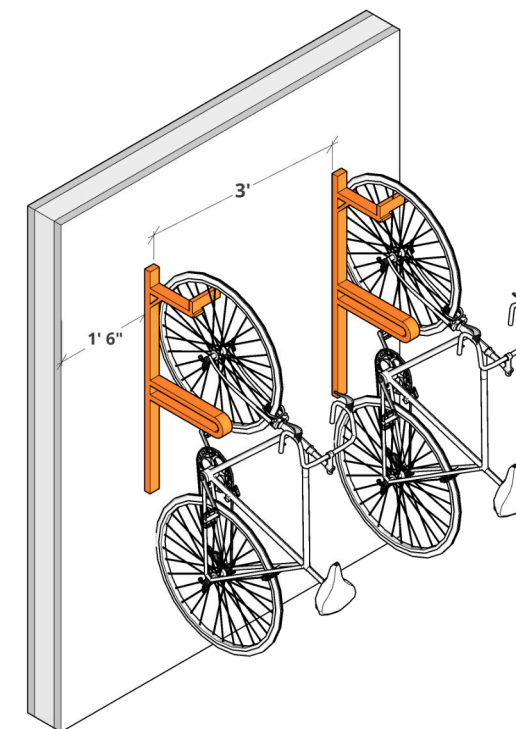

Figure 11 - Wall-mounted bicycle rack without vertical off-sets

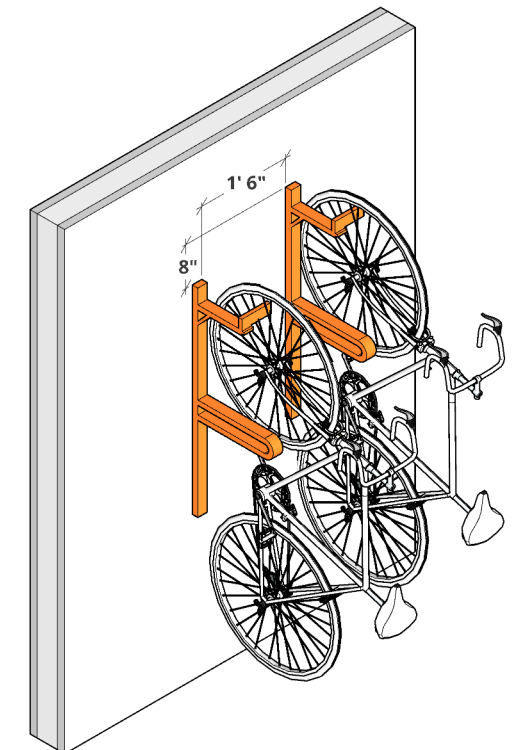

Figure 12 - Wall-mounted bicycle rack with vertical off-sets



# Long-term parking

## Vertical Spacing Continued

The minimum 5-foot access aisle between rows of vertical wall-mounted long-term bicycle parking is shown below in Figure 13.

For example models of qualifying wall-mounted bike racks, please see [page 22](#).

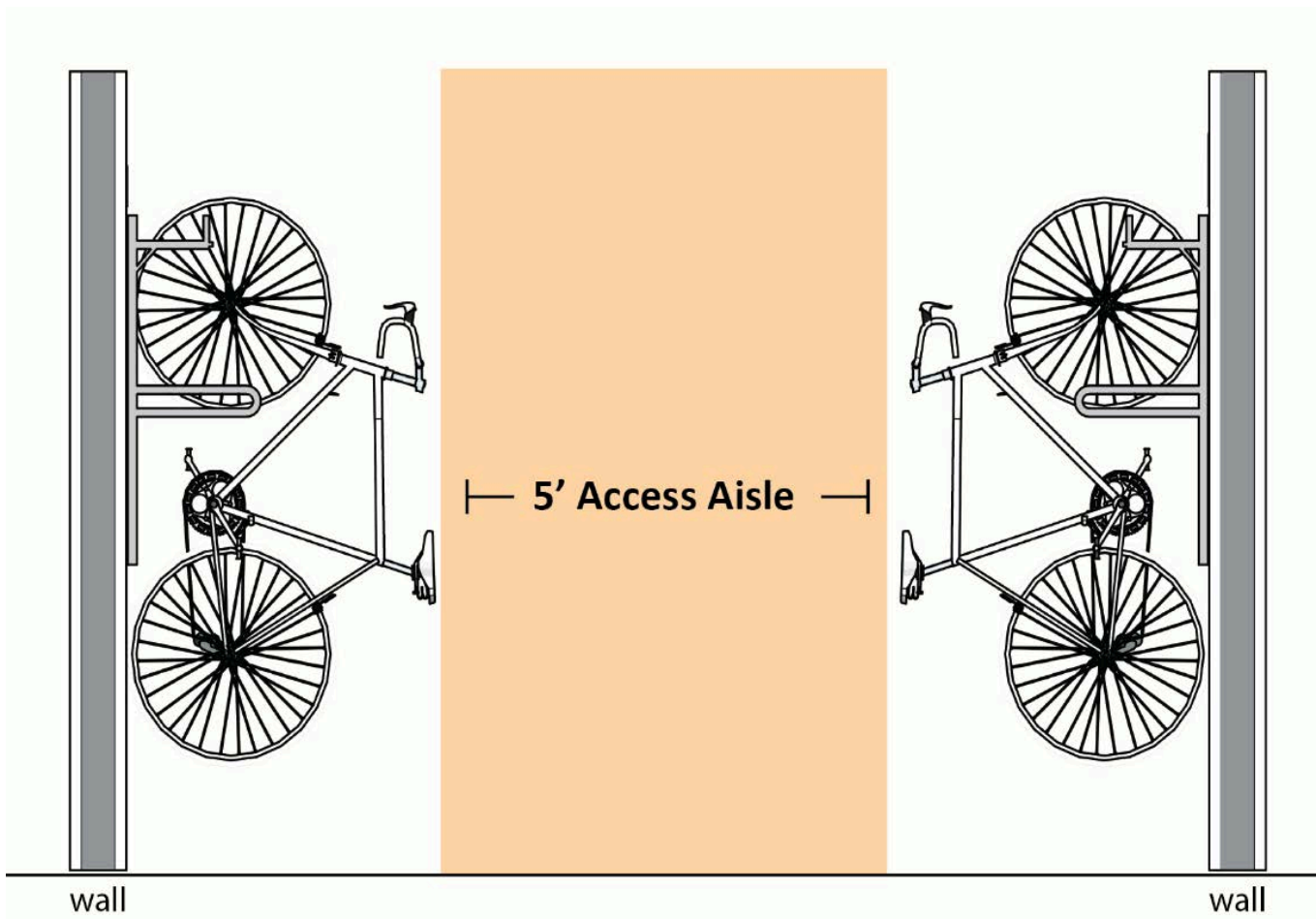

Figure 13 - Wall-mounted vertical bike rack access aisle



Source: [getmyPARKING.com](http://getmyPARKING.com)

## Bike Lockers

Bike lockers satisfy the requirement for long-term bicycle parking spaces. Bike lockers must be permanently anchored, enclosed and secured.

Typical minimum bike locker dimensions are shown below in Figure 14.

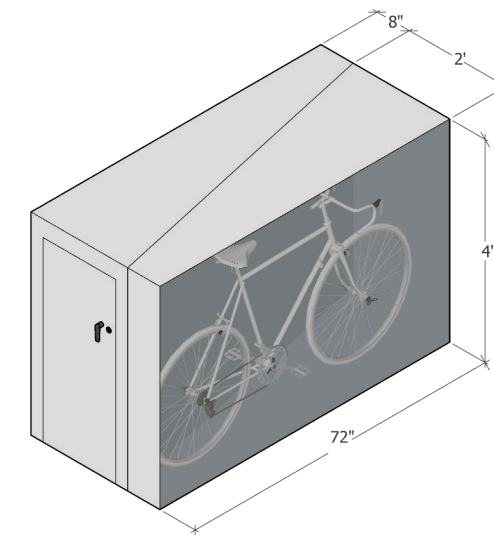

This style of bike locker holds two bikes.

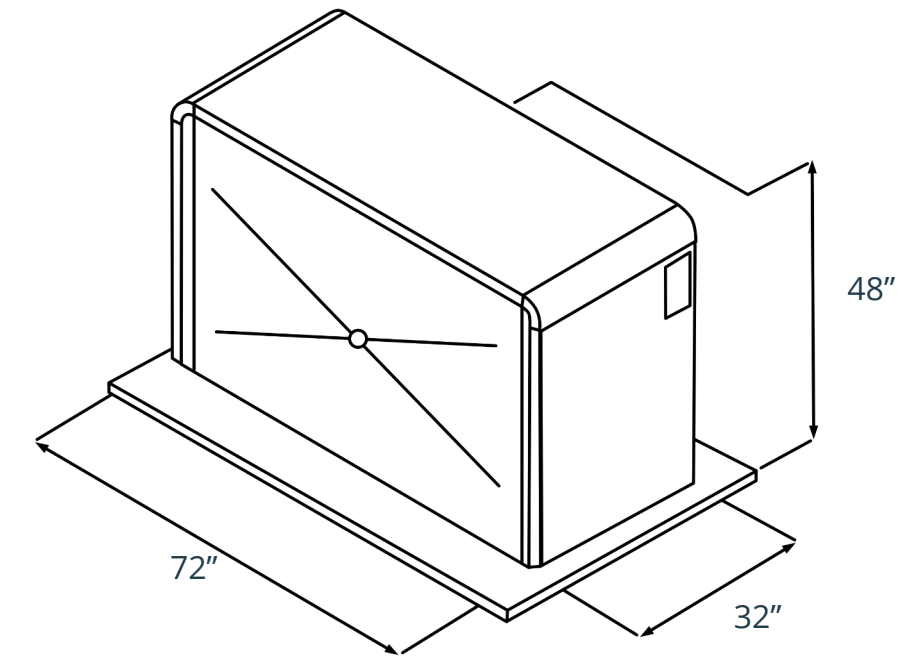
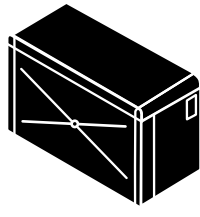
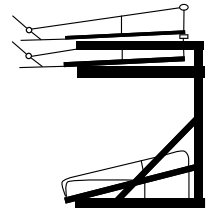
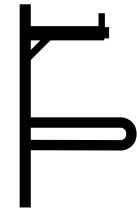
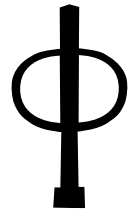
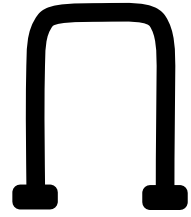

Figure 14 - Typical minimum bike locker dimensions.

For example models of qualifying bike lockers, please see [page 20](#).



# Recommended Bike Parking Models



Inverted-U Racks		Hitch Racks / Post & Ring		Vertical Racks		Double-decker racks		Bike Lockers	
Make	Model	Make	Model	Make	Model	Make	Model	Make	Model
Kinetic	<a href="#">Staple Rack</a>	Kinetic	<a href="#">Hitch Rack</a>	Kinetic	<a href="#">Vertical Rack</a>	Kinetic	<a href="#">Double Lift</a>	American Bicycle Security Company	<a href="#">Bike-Shell Model 302</a>
Saris	<a href="#">Bike Dock</a>	Madrax	<a href="#">Post and Ring</a>	Saris	<a href="#">Bike Trac</a>	Saris	<a href="#">Stack Rack</a>	Dero	<a href="#">D1 Bike Locker Single</a>
Dero	<a href="#">Hoop Rack</a>	Dero	<a href="#">Bike Hitch</a>	Madrax	<a href="#">Wall Rack</a>	Dero	<a href="#">Dero Duplex</a>	Madrax	<a href="#">Madlocker</a>
Madrax	<a href="#">U Bike Rack</a>	Saris	<a href="#">Post and Ring</a>	Dero	<a href="#">Ultra Space Saver</a>	Madrax	<a href="#">Bike Boost Storage</a>	Urban Racks	<a href="#">Urban Twin Locker</a>
Urban Racks	<a href="#">Urban Staple</a>			Urban Racks	<a href="#">Urban High Density</a>	Urban Racks	<a href="#">Urban Double Stacker</a>	CycleSafe	<a href="#">PROPARK Standard Model</a>
American Bicycle Security Company	<a href="#">LA Hoop Rack</a>			American Bicycle Security Company	<a href="#">Bike File</a>			Kinetic	<a href="#">Bike Locker</a>

This page intentionally left blank

