

## CITY OF SPOKANE



### REGARDING CITY COUNCIL MEETINGS

City Council's standing committee meetings, Briefing Sessions, Legislative Sessions and study sessions are held in City Council Chambers – Lower Level of City Hall, 808 W. Spokane Falls Blvd.

City Council Members, City staff, presenters and members of the public have the option to participate virtually via WebEx during all meetings, with the exception of Executive Sessions which are closed to the public. Call in information for the November 4, 2024, meetings is below. All meetings will be streamed live on Channel 5 and online at <https://my.spokanecity.org/citycable5/live> and <https://www.facebook.com/spokanecitycouncil>.

#### **WebEx call in information for the week of November 4, 2024:**

3:30 p.m. Briefing Session: 1-408-418-9388; access code: 249 250 76017; password: 0320

6:00 p.m. Legislative Session: 1-408-418-9388; access code: 249 538 30144; password: 0320

Thursday Study Session: 1-408-418-9388; access code: 249 143 67432; password: 0320

#### **To participate in public comment (including Open Forum):**

Testimony sign-up is open beginning at 5:00 p.m. on Friday, November 1, 2024, and ending at 6:00 p.m. on Monday, November 4, 2024, via the online testimony sign-up form link which can be accessed by clicking <https://forms.gle/Vd7n381x3seaL1NW6> or in person outside council chambers beginning at 8:00 a.m. on November 4, 2024. You must sign up by 6:00 p.m. to be called on to testify. (If you are unable to access the form by clicking the hyperlink, please copy and paste the link address into your browser window.) Instructions for participation are provided on the form when you sign up.

The open forum is a limited public forum; all matters discussed in the open forum shall relate to the affairs of the City and not relating to the current or advance agendas, pending hearing items, or initiatives or referenda in a pending election. "Affairs of the city" shall include (i) matters within the legislative, fiscal or regulatory purview of the city, (ii) any ordinance, resolution or other official act adopted by the city council, (iii) any rule adopted by the city, (iv) the delivery of city services and operation of city departments, (v) any act of members of the city council, the mayor or members of the administration, or (vi) any other matter deemed by the council president to fall within the affairs of the city, which determination may be overridden by majority vote of the council members present. Individuals speaking during the open forum shall address their comments to the council president and shall maintain decorum as laid out in Rule 2.15 (Participation by Members of the Public in Council Meetings).

## **CITY COUNCIL MEETINGS RULES – PUBLIC DECORUM**

**Strict adherence to the following rules of decorum by the public will be observed and adhered to during City Council meetings, including open forum, public comment period on legislative items, and Council deliberations:**

- 1. No Clapping!**
- 2. No Cheering!**
- 3. No Booing!**
- 4. No public outbursts!**
- 5. Two-minute time limit for comments made during open forum, and three-minute time limit on public testimony regarding legislative items!**

**In addition, please silence your cell phones when entering the Council Chambers!**

Further, keep the following City Council Rules in mind:

### **Rule 2.2 OPEN FORUM**

- A. After the conclusion of all legislative business, the council shall recess briefly and then convene for an open forum, unless a majority of council members vote otherwise. The open forum shall have twenty (20) spaces available. The individuals assigned to the twenty (20) spaces available will be chosen at random, with preference given to individuals who have not spoken at open forum during that calendar month. The council shall conclude open forum after twenty (20) speakers unless a majority of council members vote to allow additional speakers. The city clerk and other staff shall not be required to remain in attendance during the open forum. Nothing in this Rule 2.2 shall be deemed to require open forum or the legislative session to continue after 10:00 p.m., or to require open forum during a council “Town Hall” meeting contrary to Rule 2.14.F.
- B. Members of the public can sign up for open forum beginning no later than 5:00 p.m. on the Friday immediately preceding the legislative session and ending at 6:00 p.m. on the date of the meeting via the virtual testimony form linked in the meeting packet or in person outside council chambers beginning at 8:00 a.m. on the day of the legislative session. Speakers must sign themselves in using a name. Members of the public who are unable to sign up during the sign-up period or who attempt to sign up late will be added to the list of speakers at the discretion of the chair, or their designee. The order of the speakers will be determined at the discretion of the chair, taking into account any special accommodations for persons of limited English proficiency as provided in Rule 2.2.F below. Each speaker shall be limited to no more than two (2) minutes unless a majority of the council members in attendance vote on an alternate time limit.
- C. No action, other than a statement of council members’ intent to address the matter in the future, points of order, or points of information will be taken by council members during an open forum.
- D. The open forum is a limited public forum and all matters discussed in the open forum shall relate to the affairs of the city. “Affairs of the city” shall include (i) matters within the legislative, fiscal or regulatory purview of the city, (ii) any ordinance, resolution or other official act adopted by the city council, (iii) any rule adopted by the city, (iv) the delivery of city services and operation of city departments, (v) any act of members of the city council, the mayor or members of the administration, or (vi) any other matter deemed by the council president to fall within the affairs of the city, which determination may be overridden by majority vote of the council members present. Absent permission of the chair, no person shall be permitted to speak in open forum regarding items on that week’s current agenda or the next week’s advanced agenda, pending hearing items, or initiatives or referenda in a pending election. Legal or personal matters between private parties that do not impact the governance of the City of Spokane are not a permissible topic of open forum testimony.
- E. No person shall be permitted to display visual information during open forum, including but not limited to presentations, videos, or other media; however, members of the public may share this information with the council by emailing them at [citycouncil2@spokanecity.org](mailto:citycouncil2@spokanecity.org). Individuals speaking during open forum shall address their comments to the council president, and speakers as well as members of the audience shall comply with Rule 2.15 (Participation by Members of the Public in Council Meetings).
- F. Participation of individuals with limited English language proficiency in open forum shall be accommodated to the extent set forth in Rule 2.15.J.

### **Rule 2.7 SERVICE ANIMALS AT CITY COUNCIL MEETINGS**

- A. For purposes of these Rules, only dogs that are individually trained to do work or perform tasks for a person with a disability are recognized as service animals. Dogs or other animals whose sole function is to provide comfort or emotional support do not qualify as service animals under these Rules. Service animals are permitted to accompany people with disabilities in City Council meetings, as well as all areas where members of the public are allowed to go.

- B. Service animals must, at all times while present in a City Council meeting, be harnessed, leashed, or tethered, unless these devices interfere with the service animal's work or the individual's disability prevents using these devices, in which case, the individual must maintain control of the animal through voice, signal, or other effective controls.

## **Rule 2.15 PARTICIPATION OF MEMBERS OF THE PUBLIC IN COUNCIL MEETINGS**

The council encourages public participation in the legislative process. Council meetings shall be conducted in a manner that provides the opportunity for all attendees to hear, see and participate in the proceedings to the extent provided in these Rules and applicable city, state, and federal law. Speech or conduct that disrupts, disturbs, or otherwise impedes the orderly conduct of any council meeting is prohibited. In addition to these general principles governing public participation, the following specific rules apply:

- A. Members of the public may address the council regarding the following items during the council's legislative session: the consent agenda as a whole, all first reading ordinances together (with the exception of first reading ordinances associated with hearings, which shall be taken separately), final readings of regular and special budget ordinances, emergency ordinances, hearing items, special considerations, and other items before the city council requiring council action, except those that are adjudicatory or solely administrative in nature. This rule shall not limit the public's right to speak on issues that are not part of the current or advanced agendas during open forum.
- B. No member of the public may speak without first being recognized for that purpose by the chair. Except for named parties to an adjudicative hearing, a person may be required to sign a sign-up sheet and provide their city of residence as a condition of recognition. Council members must be recognized by the chair for the purpose of obtaining the floor.
- C. Each person speaking in a public council meeting shall verbally identify themselves by name, city of residence, and, if appropriate, representative capacity.
- D. Each speaker shall follow all written and verbal instructions so that verbal remarks are electronically recorded, and documents submitted for the record are identified and marked by the clerk.
- E. Those who wish to provide commentary but do not wish to give verbal comments at the podium may provide written comments to the council via letter or electronic mail.
- F. No person shall be permitted to conduct demonstrations, display banners, hold signs, applaud or boo speakers, use profanity, vulgar language or obscene speech, yell or make comments that attack or verbally insult any individual, or engage in other such disorderly conduct that disrupts, disturbs, or otherwise impedes the orderly conduct of the proceedings.
- G. Standing is permitted so long as doing so maintains compliance with applicable fire codes and the Americans with Disability Act (ADA), does not interfere with reserved seating areas, and does not impede access to entrances and exits to the Council Chambers, aisles, or pathways inside the Council Chambers. Attendees shall be mindful not to obstruct the views of others in Council Chambers when standing.
- H. A speaker asserting a statement of fact may be asked by a council member to document and identify the sources of the factual datum being asserted.
- I. When addressing the council, members of the public shall direct all remarks to the council president, shall refrain from remarks directed personally to any council member or any other individual, and shall confine remarks to the matters that are specifically before the council at that time.
- J. City employees or city officials (including members of city boards and commissions) may participate in public comment, including open forum, providing they are in compliance with the City of Spokane Code of Ethics and they do the following:
  - 1. Announce at the beginning of their testimony that they are there in their personal capacity or their capacity as a member of a relevant board, commission, committee or community group;
  - 2. Protect confidential information, including, but not limited to, confidential financial information and attorney-client communications;
  - 3. Do not use, or be perceived to use, city funds, including giving testimony during paid work time or while in uniform; or city property, including using a city-issued computer or cell phone, in giving testimony.
- K. When any person, including members of the public, city staff, and others, are addressing the council, council members shall observe the same decorum and process as the rules require among the members *inter se*. That is, a council member shall not engage the person addressing the council in colloquy but shall speak only when granted the floor by the council president. All persons and/or council members shall not interrupt one another. The duty of mutual respect and avoiding unlawful harassment set forth in Rule 1.2 and the rules governing debate set forth in *Robert's Rules of Order, Newly Revised*, shall extend to all speakers before the city council. The city council's policy advisor and/or a city attorney shall, with the assistance of council staff, assist the council president to ensure that all individuals desiring to speak shall be identified,

appropriately recognized, and provided the opportunity to speak. All persons attending city council meetings or city council sponsored meetings shall refrain from harassing other attendees or risk being removed and/or prohibited from attending future meetings.

- L. The city council intends to fully comply with chapter 18.11 SMC, Language Access in Municipal Proceedings. Rules regarding participation of individuals in council proceedings, including legislative sessions and open forum, shall be deemed amended to conform to any Language Access Plan adopted by the council pursuant to SMC 18.11.030. Except as otherwise provided in an adopted Language Access Plan, individuals with limited English language proficiency are encouraged to contact the council office director at least five (5) days prior to a scheduled legislative session for assistance with the signing up to testify or to arrange translation or interpretation assistance.
- M. City council legislative sessions are regularly video and audio recorded and available online (<https://vimeo.com/spokanecitycouncil>). Members of the public may also photograph or film council proceedings so long as doing so maintains compliance with applicable fire codes and the Americans with Disability Act (ADA), does not interfere with reserved seating areas, and does not impede access to entrances and exits to the Council Chambers, aisles, or pathways inside the Council Chambers. Attendees shall be mindful not to obstruct the views of others in Council Chambers when photographing or recording. No flash photography or other lighting is permitted.
- N. RCW 42.17A.555 generally prohibits the use of city facilities for electioneering. Therefore, no person may use the council meeting or facilities for the purpose of assisting a campaign for election of any person to any office, or for the promotion of or opposition to any ballot proposition. In this context, the term “facilities” includes council chambers, the council gallery and the speaking opportunities available through the public comment and open forum procedures set forth in these rules.

#### **Rule 2.16 PUBLIC TESTIMONY REGARDING LEGISLATIVE AGENDA ITEMS – TIME LIMITS**

- A. Members of the public can sign up to give testimony beginning no later than 5:00 p.m. on the Friday immediately preceding the legislative session and ending at 6:00 p.m. on the date of the meeting via the online testimony sign-up form linked in the meeting packet or in person outside council chambers beginning at 8:00 a.m. on the day of the legislative session. Speakers must sign in using a name. Members of the public who are unable to sign up during the sign-up period or who attempt to sign up late will not be added to the list of speakers. The order of the speakers shall be determined at the discretion of the chair.
- B. The city council shall take public testimony on all matters included on its legislative agenda as described at Rule 2.15(A), with those exceptions stated in Rule 2.16(B). Public testimony shall be limited to the final council action, except that public testimony shall be allowed at the first reading of ordinances. Public testimony shall be limited to three (3) minutes per speaker. The chair, absent a majority vote of the council, has the authority to lower the three (3) minutes per speaker time limit by announcing the new, lower time limit at the legislative session. The chair may allow additional time if the speaker is asked to respond to questions from the council. Public testimony and consideration of an item may be extended to a subsequent meeting by a majority vote of the council. Testimony on a legislative item deferred to a future date shall be taken on the future date, unless testimony on the date of deferral is allowed by the Council President.
- C. No public testimony shall be taken on oral amendments to consent or legislative agenda items, votes to override a mayoral veto, or solely procedural, parliamentary, or administrative matters of the council.
- D. Public testimony will be taken on consent and legislative items that are moved to council’s regular briefing session or study session unless a majority of council votes otherwise during the meeting in which the items are moved.
- E. For legislative or hearing items that may affect an identifiable individual, association, or group, the following procedure may be implemented at the discretion of the council president:
  - 1. Following an assessment by the chair of factors such as complexity of the issue(s), the apparent number of people indicating a desire to testify, representation by designated spokespersons, etc., the chair shall, in the absence of objection by the majority of the council present, impose the following procedural time limitations for taking public testimony regarding legislative matters:
    - a. There shall be up to fifteen (15) minutes for staff, board, or commission presentation of background information, if any.
    - b. The designated representative of the proponents of the issue shall speak first and may include within their presentation the testimony of expert witnesses, visual displays, and any other reasonable methods of presenting the case. Up to thirty (30) minutes may be granted for the proponent’s presentation. If there be more than one designated representative, they shall allocate the allotted time between or among themselves.
    - c. Following the presentation of the proponents of the issue, three (3) minutes shall be granted for any other person not associated with the designated representative of the proponents who wishes to

Speak on behalf of the proponent's position.

- d. The designated representative, if any, of the opponents of the issue shall speak following the presentation of the testimony of expert witnesses, visual displays, and any other reasonable methods of presenting the case. The designated representative(s) of the opponents shall have the same amount of time which was allotted to the proponents.
  - e. Following the presentation by the opponents of the issue, three (3) minutes shall be granted for any other person not associated with the designated representative of the opponents who wishes to speak on behalf of the opponents' position.
  - f. Up to ten (10) minutes of rebuttal time may be granted to the designated representative for each side, the proponents speaking first, the opponents speaking second.
2. In the event the party or parties representing one side of an issue has a designated representative and the other side does not, the chair shall publicly ask the unrepresented side if they wish to designate one or more persons to utilize the time allotted for the designated representative. If no such designation is made, each person wishing to speak on behalf of the unrepresented side shall be granted three (3) minutes to present their position, and no additional compensating time shall be allowed due to the fact that the side has no designated representative.
  3. In the event there appears to be more than two groups wishing to advocate their distinct positions on a specific issue, the chair may grant the same procedural and time allowances to each group or groups, as stated previously.
  4. In the event that the side for which individuals wish to speak is not identified, those wishing to give testimony shall be granted three (3) minutes to present their position after all sides have made their initial presentations and before each side's rebuttal period.
- F. The time taken for staff or council member questions and responses thereto shall be in addition to the time allotted for any individual or designated representative's testimony.
- G. No person shall be permitted to display visual information during their testimony, including but not limited to presentations, videos, or other media; however, members of the public may share this information with the council by emailing them at [citycouncil2spokanecity.org](mailto:citycouncil2spokanecity.org).
- H. In addition to in-person or remote verbal testimony, testimony may also be submitted by mail to City Council Office, Spokane City Hall, 808 W. Spokane Falls Blvd., Spokane, WA, 99201, by email to all council members, or via the contact form on the council's website.<sup>1</sup>

---

<sup>1</sup> <https://my.spokanecity.org/citycouncil/members/>

# THE CITY OF SPOKANE



## CURRENT COUNCIL AGENDA

MEETING OF MONDAY, NOVEMBER 4, 2024

### **MISSION STATEMENT**

**TO DELIVER EFFICIENT AND EFFECTIVE SERVICES  
THAT FACILITATE ECONOMIC OPPORTUNITY  
AND ENHANCE QUALITY OF LIFE.**

**MAYOR LISA BROWN**

**COUNCIL PRESIDENT BETSY WILKERSON**

**COUNCIL MEMBER JONATHAN BINGLE**

**COUNCIL MEMBER MICHAEL CATHCART**

**COUNCIL MEMBER PAUL DILLON**

**COUNCIL MEMBER KITTY KLITZKE**

**COUNCIL MEMBER LILI NAVARRETE**

**COUNCIL MEMBER ZACK ZAPPONE**

**CITY COUNCIL CHAMBERS  
CITY HALL**

**808 W. SPOKANE FALLS BLVD.  
SPOKANE, WA 99201**

City of Spokane Guest Wireless access for Council Chambers for November 4, 2024:

Username: **COS Guest**

Password: **K8vCr44y**

**Please note the space in username.  
Both username and password are case sensitive.**

## **LAND ACKNOWLEDGEMENT**

We acknowledge that we are on the unceded land of the Spokane people. And that these lands were once the major trading center for the Spokanes as they shared this place and welcomed other area tribes through their relations, history, trade, and ceremony. We also want to acknowledge that the land holds the spirit of the place, through its knowledge, culture, and all the original peoples Since Time Immemorial.

As we take a moment to consider the impacts of colonization may we also acknowledge the strengths and resiliency of the Spokanes and their relatives. As we work together making decisions that benefit all, may we do so as one heart, one mind, and one spirit.

We are grateful to be on the shared lands of the Spokane people and ask for the support of their ancestors and all relations. We ask that you recognize these injustices that forever changed the lives of the Spokane people and all their relatives.

We agree to work together to stop all acts of continued injustices towards Native Americans and all our relatives. It is time for reconciliation. We must act upon the truths and take actions that will create restorative justice for all people.

Adopted by Spokane City Council on the 22nd day of March, 2021  
*via Resolution 2021-0019*

## BRIEFING AND LEGISLATIVE SESSIONS

The Briefing Session is open to the public, but will be a workshop meeting. Discussion will be limited to Council Members and appropriate Staff and Counsel. The Legislative Session is also open to the public and public comment will be taken on Legislative Session items, except those that are adjudicatory or solely administrative in nature. Following the conclusion of the Legislative Agenda, an Open Forum will be held unless a majority of Council Members vote otherwise. Please see additional Open Forum information that appears at the end of the City Council agenda.

SPOKANE CITY COUNCIL BRIEFING SESSIONS (BEGINNING AT 3:30 P.M. EACH MONDAY) AND LEGISLATIVE SESSIONS (BEGINNING AT 6:00 P.M. EACH MONDAY) ARE BROADCAST LIVE ON CITY CABLE CHANNEL FIVE AND STREAMED LIVE ON THE CHANNEL FIVE WEBSITE. THE SESSIONS ARE REPLAYED ON CHANNEL FIVE ON THURSDAYS AT 6:00 P.M. AND FRIDAYS AT 10:00 A.M.

### ADDRESSING THE COUNCIL

- No member of the public may speak without first being recognized for that purpose by the Chair. Except for named parties to an adjudicative hearing, a person may be required to sign a sign-up sheet and provide their city of residence as a condition of recognition. Council Members must be recognized by the chair for the purpose of obtaining the floor.
- Each person speaking at the public microphone shall verbally identify themselves by name, city of residency and, if appropriate, representative capacity.
- Each speaker shall follow all written and verbal instructions so that verbal remarks are electronically recorded, and documents submitted for the record are identified and marked by the Clerk. (If you are submitting letters or documents to the Council Members, please provide a minimum of ten copies via the City Clerk. The City Clerk is responsible for officially filing and distributing your submittal.)
- In order that evidence and expressions of opinion be included in the record and that decorum befitting a deliberative process be maintained, no modes of expression including but not limited to demonstrations, banners, signs, applause, profanity, vulgar language, or personal insults will be permitted. To prevent disruption of council meetings and visual obstruction of proceedings, members of the audience shall remain seated during council meetings.
- A speaker asserting a statement of fact may be asked to document and identify the source of the factual datum being asserted.
- When addressing the Council, members of the public shall direct all remarks to the Council President, and shall confine their remarks to the matters that are specifically before the Council at that time or, if speaking during Open Forum, shall confine their remarks to affairs of the city.
- City staff may participate in public comment, including open forum, providing they are in compliance with the City of Spokane Code of Ethics and they follow the steps outlined in the City Council Rules of Procedure.

**SPEAKING TIME LIMITS:** Unless the time limit is adjusted by a majority vote of the Council, each person addressing the Council shall be limited to a two-minute speaking time during Open Forum and a three-minute speaking time for other matters. The chair may allow additional time if the speaker is asked to respond to questions from the Council. Public testimony and consideration of an item may be extended to a subsequent meeting by a majority vote of the Council. Note: No public testimony shall be taken on amendments to consent or legislative agenda items, or solely procedural, parliamentary, or administrative matters of the Council, including veto overrides.

**CITY COUNCIL AGENDA:** The City Council Advance and Current Agendas may be obtained prior to Council Meetings by accessing the City's website at <https://my.spokanecity.org/citycouncil/documents/>.



# **BRIEFING SESSION**

(3:30 p.m.)

(Council Chambers Lower Level of City Hall)  
(No Public Testimony Taken)

**ROLL CALL OF COUNCIL**

**INTERVIEWS OF NOMINEES TO BOARDS AND COMMISSIONS**

**COUNCIL OR STAFF REPORTS OF MATTERS OF INTEREST**

**ADVANCE AGENDA REVIEW (Staff or Council Member briefings and discussion)**

**APPROVAL BY MOTION OF THE ADVANCE AGENDA**

**CURRENT AGENDA REVIEW (Presentation of any new background information and discussion of any adjustments)**

---

# **EXECUTIVE SESSION**

(Closed Session of Council)

(Executive Session may be held or reconvened during the 6:00 p.m. Legislative Session)

---

# **LEGISLATIVE SESSION**

(6:00 P.M.)

(Council Reconvenes in Council Chamber)

**PLEDGE OF ALLEGIANCE**

**WORDS OF INSPIRATION AND SPECIAL INTRODUCTIONS**

**ROLL CALL OF COUNCIL**

**PROCLAMATIONS AND SALUTATIONS**

**REPORTS FROM COMMUNITY ORGANIZATIONS**

**ANNOUNCEMENTS**

(Announcements regarding Changes to the City Council Agenda)

# NO BOARDS AND COMMISSIONS APPOINTMENTS

## CONSENT AGENDA

The consent agenda consists of purchases and contracts for supplies and services provided to the city, as well as other agreements that arise (such as settlement or union agreements), and weekly claims and payments of previously approved obligations and biweekly payroll claims against the city. Any agreement over \$50,000 must be approved by the city council. Typically, the funding to pay for these agreements has already been approved by the city council through the annual budget ordinance, or through a separate special budget ordinance. If the contract requires a new allocation of funds, that fact usually will be indicated in the summary of the contract in the consent agenda.

Unless a council member requests that an item be considered separately, the council approves the consent agenda as a whole in a single vote. Note: The consent agenda is no longer read in full by the city clerk. The public is welcome to testify on matters listed in the consent agenda, but individual testimony is limited to three minutes for the entire consent agenda.

### REPORTS, CONTRACTS AND CLAIMS

### RECOMMENDATION

- |  |                |               |
|--|----------------|---------------|
| 1. Purchases from Pape Machinery (Spokane) for the Waste to Energy Facility of:  | Approve<br>All |               |
| a. John Deere 316GR Skid Steer Loader—\$64,234.67 (incl. tax).   |                | OPR 2024-0924 |
| b. John Deere 85P Tier Excavator equipped with a waste grapple, 18" bucket and thumb—\$171,671.04 (incl. tax).   |                | OPR 2024-0925 |
| (Council Sponsors: Council President Wilkerson and Council Members Bingle and Klitzke)   |                |               |
| 2. Contract Renewal 1 of 4 with Clean Energy dba Clean Energy Corp. (Newport Beach, CA) for operation and maintenance services for the compressed natural gas (CNG) site from October 1, 2024, to September 30, 2025—\$250,000 (plus applicable tax). (Council Sponsors: Council President Wilkerson and Council Members Bingle and Klitzke) | Approve        | OPR 2023-1095 |

- |   |                        |   |
|---|------------------------|---|
| <p>3. Five-year Value Blanket with Oxarc (Spokane) for the as-needed purchase of hydrochloric acid for use at the Waste to Energy Facility from January 1, 2025, to December 31, 2029—not to exceed \$625,000 (plus tax) (\$125,000 annually). (Council Sponsors: Council President Wilkerson and Council Members Bingle and Klitzke)</p>                     | <p>Approve</p>         | <p>OPR 2024-0926<br/>ITB 6063-24</p>    |
| <p>4. Value Blanket Renewal 2 of 4 with Helfrich Brothers Boiler Works, Inc. (Lawrence, MA) for the purchase of superheater tube panels for use at the Waste to Energy Facility from December 15, 2024, to December 14, 2025—not to exceed \$3,750,000 (plus tax). (Council Sponsors: Council President Wilkerson and Council Members Bingle and Klitzke)</p> | <p>Approve</p>         | <p>OPR 2022-0901<br/>ITB 5754-22</p>    |
| <p>5. Value Blanket Renewal 4 of 4 with WEMCO, Inc. (Spokane) for the as-needed purchase of mechanical OEM parts for the refuse crane system at the Waste to Energy Facility from December 1, 2024, to November 30, 2025—not to exceed \$160,000 (plus tax). (Council Sponsors: Council President Wilkerson and Council Members Bingle and Klitzke)</p>       | <p>Approve</p>         | <p>OPR 2020-0855<br/>RFQ 5338-20</p>    |
| <p>6. Contract renewal 3 of 4 with Knight Const. &amp; Supply, Inc. (Deer Park, WA) for mechanical repairs at the Waste to Energy Facility from November 1, 2024, to October 31, 2025—not to exceed \$2,200,000 (plus tax). (Council Sponsors: Council President Wilkerson and Council Members Bingle and Klitzke)</p>  | <p>Approve</p>         | <p>OPR 2021-0716<br/>PW ITB 5506-21</p> |
| <p>7. Contracts for the transportation of topsoil to the Northside Landfill for the Solid Waste Disposal Department from November 15, 2024, to November 14, 2025 with:</p>  | <p>Approve<br/>All</p> | <p>RFQ 6237-24</p>                      |
| <p style="padding-left: 40px;">a. Action Materials (Spokane)—not to exceed \$65,000 (plus tax).</p>   |                        | <p>OPR 2024-0927</p>                    |
| <p style="padding-left: 40px;">b. Circle M Construction &amp; Landscape Supplies, Inc. (Spokane Valley, WA)—not to exceed \$65,000 (plus tax).</p>  |                        | <p>OPR 2024-0928</p>                    |
| <p>(Council Sponsors: Council President Wilkerson and Council Members Bingle and Klitzke)</p>   |                        |   |
| <p>8. Public Works Agreement with Industrial Service Solutions aka Bay Valve Service, LLC (Longview, WA) for on-site valve repair services at the Waste to Energy</p>   | <p>Approve</p>         | <p>OPR 2024-0929<br/>ITB 6163-24</p>    |

Facility from January 1, 2025, to December 31, 2025—not to exceed \$150,000 (plus tax). (Council Sponsors: Council President Wilkerson and Council Members Bingle and Klitzke)

9. Five-year Preventative Maintenance Agreements with WEMCO, Inc. (Spokane) for the Waste to Energy Facility from January 1, 2025, to December 31, 2029, for:
- Approve All
- a. Crane, hoist, trolley and lifeline preventative maintenance and inspections—not to exceed \$430,000 (plus tax) (\$86,000 annually). OPR 2024-0930  
ITB 6184-24
  - b. Bridge crane maintenance and inspections—not to exceed \$370,000 (plus tax) (\$74,000 annually). OPR 2024-0931  
ITB 6185-24
- (Council Sponsors: Council President Wilkerson and Council Members Bingle and Klitzke)
10. Purchase from Titan Truck Equipment (Spokane Valley, WA) of two service truck bodies for the Water Department—\$121,693.42 (incl. tax). (Council Sponsors: Council President Wilkerson and Council Members Bingle and Klitzke) Approve OPR 2024-0932  
RFQ 6224-24
11. Purchase from Core & Main (Spokane Valley, WA) of miscellaneous water product fittings for connections to the new West Plains Booster Station project—\$177,300.46 (incl. tax). (Council Sponsors: Council President Wilkerson and Council Members Bingle and Klitzke) Approve OPR 2024-0933  
RFQ 6230-24
12. Public Works Agreement with K&N Electric Motors, Inc. (Spokane Valley, WA) to replace the failing trash rake on Powerhouse 2 at the Upriver Hydroelectric Project—\$1,246,438.37. (Council Sponsors: Council President Wilkerson and Council Members Bingle and Klitzke) Approve OPR 2024-0934  
PW ITB 6208-24
13. Purchases from Salt Distributors, Inc. (Spokane Valley, WA) for the Streets Department of:
- Approve All
- a. Road Salt—\$140,000. OPR 2024-0935
  - b. Ice Kicker—\$115,000. OPR 2024-0936
- (Council Sponsors: Council President Wilkerson and Council Members Bingle and Klitzke)

- |   |                |                                      |
|---|----------------|--------------------------------------|
| <b>14. Public Works Contract with NRC Environmental Services, Inc. (Seattle, WA) for as-needed removal of hazardous materials for various City of Spokane locations from September 30, 2024, to December 31, 2024—\$80,476 (plus applicable tax). (Council Sponsors: Council President Wilkerson and Council Members Bingle and Klitzke)</b>  | <b>Approve</b> | <b>OPR 2024-0937</b>                 |
| <b>15. Outside Special Counsel Contract Amendment with Keating Bucklin &amp; McCormack (Seattle, WA) in the legal matter of Estate of Robert Bradley, et al. v. City of Spokane—additional \$150,000. Total Contract Amount: \$400,000. (Council Sponsors: Council President Wilkerson and Council Members Bingle and Klitzke)</b>  | <b>Approve</b> | <b>OPR 2023-0240</b>                 |
| <b>16. Contract Amendment with Kittelson &amp; Associates, Inc. (Spokane) to continue design development for public infrastructure projects within the West Central Neighborhood portion of the West Quadrant Tax Increment Finance District—additional \$299,677 (plus applicable tax). (Council Sponsors: Council President Wilkerson and Council Members Bingle and Klitzke)</b> | <b>Approve</b> | <b>OPR 2023-1249</b>                 |
| <b>17. Amendment to Consultant Agreement with McMillen, Inc. (Boise, ID) for construction management and engineering support services for Upriver Dam through December 31, 2025—additional \$123,588 (plus applicable tax). (Council Sponsors: Council President Wilkerson and Council Members Bingle and Klitzke)</b>  | <b>Approve</b> | <b>OPR 2023-0884</b>                 |
| <b>18. Amendment No. 5 to the Interlocal Agreement between the City of Spokane and Spokane County for transfer and disposal services at the City's Waste to Energy Facility—\$8,000,000 Revenue. (Council Sponsors: Council President Wilkerson and Council Members Bingle and Klitzke)</b>   | <b>Approve</b> | <b>OPR 2014-0060</b>                 |
| <b>19. Contract Amendment with Waste Management of Washington, Inc. (Kirkland, WA) for the transportation and disposal of bypass waste from the Waste to Energy Facility and County Transfer Stations. (Council Sponsors: Council President Wilkerson and Council Members Bingle and Klitzke)</b>   | <b>Approve</b> | <b>OPR 2023-1043<br/>RFP 5817-23</b> |
| <b>20. Low Bid of Apollo Inc. (Kennewick, WA) for Plains Booster Station Replacement project—\$4,698,520.10 (plus tax). An administrative reserve of \$469,852.01</b>   | <b>Approve</b> | <b>OPR 2024-0938<br/>ENG 2018102</b> |

(plus tax), which is 10% of the contract price, will be set aside. (West Hills Neighborhood) (Council Sponsors: Council President Wilkerson and Council Members Bingle and Klitzke)

- 21. Administrative reserve increase to the contract with Shamrock Paving (Spokane) for 2023 Residential Chip Seal project due to project cost overruns—\$90,000. (Council Sponsors: Council President Wilkerson and Council Members Bingle and Klitzke) Approve OPR 2023-0851  
ENG 2023043
  
- 22. Administrative reserve increase to the contract with Hamilton Construction (Springfield, OR) for the Washington/Stevens Bridge Deck Repair project due to additional repairs—\$500,000. (Council Sponsors: Council President Wilkerson and Council Members Bingle and Klitzke) Approve OPR 2024-0164  
ENG 2021088
  
- 23. Amendment to Consultant Agreement with Parametrix, Inc. (Spokane) for Construction Management Services 2024-2025 (non-federal aid) projects for an additional amount of \$800,000. Total Contract Amount: \$1,600,000. (Various Neighborhoods). (Council Sponsors: Council President Wilkerson and Council Members Bingle and Klitzke) Approve OPR 2023-1197  
ENG 2023117
  
- 24. Amendment to Value Blanket with ATS Inland Northwest, LLC (Spokane Valley, WA) for the standardized purchase of HVAC equipment and controls upgrades for the HVAC system at Fire Station 1—additional \$160,000 (plus tax). Total Purchase Amount not to exceed: \$1,010,000. (Council Sponsors: Council President Wilkerson and Council Members Bingle and Klitzke) Approve OPR 2023-0978
  
- 25. Amendment to Master Installation Contract with ATS Inland Northwest, LLC (Spokane Valley, WA) for the replacement of HVAC equipment and full controls upgrades for the HVAC system at Fire Station 1—additional \$329,320 (plus tax). Total Contract Amount not to exceed \$1,025,000. (Council Sponsors: Council President Wilkerson and Council Members Bingle and Klitzke) Approve OPR 2023-0979
  
- 26. Public Works Agreement with Bozco Construction, LLC (Mead, WA) for the demolition and replacement of the courtyard water feature at the West Central Community Center from November 11, 2024, through October 31, 2025—\$67,900 (plus applicable tax) (plus Approve OPR 2024-0939  
IPWQ 6225-24

10% administrative reserve of \$6,790). (Council Sponsors: Council President Wilkerson and Council Members Bingle and Klitzke)

- 27. Public Works Agreement with Colvico, Inc. (Spokane) for the Spokane Water Department electrical supply upgrade from November 11, 2024, through October 31, 2025—\$269,460.09 (plus applicable tax) (plus 10% administrative reserve of \$26,946.01). (Council Sponsors: Council President Wilkerson and Council Members Bingle and Klitzke) Approve OPR 2024-0940  
PW ITB 6219-24
  
- 28. Report of the Mayor of pending: Approve & Authorize Payments CPR 2024-0002
  - a. Claims and payments of previously approved obligations, including those of Parks and Library, through October 25, 2024, total \$7,183,538.73, with Parks and Library claims approved by their respective boards. Warrants excluding Parks and Library total \$6,677,171.27. CPR 2024-0003
  - b. Payroll claims of previously approved obligations through October 26, 2024: \$9,516,549.61. CPR 2024-0003
  
- 29. a. City Council Meeting Minutes: October 14, October 21, and October 24, 2024. Approve All CPR 2024-0013
- b. City Council Public Safety and Community Health Standing Committee Meeting Minutes: October 7, 2024. CPR 2024-0018

---

# LEGISLATIVE AGENDA

## NO SPECIAL BUDGET ORDINANCES

### EMERGENCY ORDINANCES

(Require Five Affirmative, Recorded Roll Call Votes)

The following item was deferred until after the roundtables and town hall relating to homelessness have concluded (during the October 28, 2024, 3:30 p.m. Briefing Session) (ORD C36570):

~~ORD C36570 Relating to the siting and operation of city-owned and city-funded facilities, amending Sections 12.05.005, 12.05.062, and 12.05.063 of the Spokane Municipal Code, and declaring an emergency. (Deferred from~~

~~October 14, 2024, Advance Agenda during the October 7, 2024, 3:30 p.m. Briefing Session) (Council Sponsors: Council Members Cathcart and Bingle)~~

## **RESOLUTIONS & FINAL READING ORDINANCES**

(Require Four Affirmative, Recorded Roll Call Votes)

- RES 2024-0101** Relating to the Traffic Calming Fund and requesting the mayor use traffic calming funds to install a stop sign and speed tables on the Post Street Bridge. (Council Sponsors: Council President Wilkerson and Council Members Zappone and Cathcart)
- RES 2024-0102** Updating the City of Spokane's "School Zone Speed Limit Schedule" Resolution which was adopted on October 25, 2021. (Council Sponsors: Council President Wilkerson and Council Members Bingle and Klitzke)
- RES 2024-0103** "27 by 2027" Resolution proposing development of a connected 27-mile urban mobility network by the end of 2027. This network will connect low-volume, low-speed neighborhood (local access) streets to major city and regional pathways, using adaptive design strategies. The network will also use some permanent infrastructure and enhanced crossing devices, such as Ped Hybrid Beacons and Rectangular Rapid Flashing Beacons to make intersection crossings safe for people walking, bicycling, or rolling with adaptive devices. (Council Sponsors: Council President Wilkerson and Council Members Bingle and Klitzke)
- RES 2024-0104** Declaring Whitney Equipment Company, Inc. (Woodinville, WA) a sole-source provider and authorizing the City to enter into a value blanket order for Flygt Products for a five (5) year period without public bidding—\$500,000. (Council Sponsors: Council President Wilkerson and Council Members Bingle and Klitzke)
- RES 2024-0105** Regarding amendment to the City of Spokane Water and Hydroelectric Department – Fee & Cost Schedule for 2025. (Council Sponsors: Council President Wilkerson and Council Member Klitzke)
- ORD C36575** Regarding the preservation of salvageable material; amending section 08.02.031 of the Spokane Municipal Code; adopting a new chapter 15.06 to Title 15 of the Spokane Municipal Code. (Deferred from September 30, 2024, Agenda) (Council Sponsors: Council Members Klitzke and Dillon)

### Dillon Proposed Amendment:

- Request motion to amend Final Reading Ordinance C36575 with proposed amendment filed November 1, 2024, and included in agenda packet under Final Reading Ordinance C36575.



Cathcart Proposed Amendment:

- Request motion to amend Final Reading Ordinance C36575 with proposed amendment filed November 1, 2024, and included in agenda packet under Final Reading Ordinance C36575.

- ORD C36596 (To be considered under Hearings Item H1.)
- ORD C36597 Relating to council membership on the Community Housing and Human Services Board, and amending Section 04.34A.030 of the Spokane Municipal Code. (Council Sponsors: Council Members Zappone, Dillon, and Navarrete)
- ORD C36598 (To be considered under Hearings Item H2.b.)
- ORD C36599 (To be considered under Hearings Item H3.b.)

**FIRST READING ORDINANCES**

- ORD C36600 Relating to oversight of transportation infrastructure, amending Section 04.40.050 of the Spokane Municipal Code, and repealing sections 12.01.200 through 12.01.210 of the Spokane Municipal Code. (Council Sponsors: Council President Wilkerson and Council Member Zappone)

Zappone Proposed Amendment:

- Request motion to amend First Reading Ordinance C36600 with proposed amendments filed October 31, 2024, and included in agenda packet under First Reading Ordinance C36600.

- ORD C36601 Relating to revenue from automated safety cameras, renaming the Traffic Calming Fund the “Spokane Safe Streets for All Fund,” amending Sections 07.08.148, 16A.64.220 and 16A.64.240 of the Spokane Municipal Code, and repealing Section 16A.64.260 of the Spokane Municipal Code. (Council Sponsors: Council Members Zappone, Klitzke, and Dillon)
- ORD C36602 Relating to sewers, amending SMC section 13.03.0508; adopting new sections 13.03.0125, 13.03.0225, and 13.03.0501, to chapter 13.03 of the Spokane Municipal Code; and setting an effective date. (Council Sponsors: Council President Wilkerson and Council Members Bingle and Klitzke)

FURTHER ACTION DEFERRED

---

**NO SPECIAL CONSIDERATIONS**

---

## HEARINGS

### RECOMMENDATION

- |  |  |                             |
|--|--|-----------------------------|
| <p><b>H1. Final Reading Ordinance C36596 amending Title 17 of the Spokane Municipal Code to update land use application procedures which clarify, expedite, and consolidate the land use permitting process in accordance with Senate Bill 5290. Specifically amending Section 17A.020.030 “C” Definitions, Section 17A.020.200 “T” Definitions, Section 17E.020.080 Application Submittal Requirements, Section 17E.030.060 Establishment of Development Permit, Section 17E.040.080 Application Submittal Requirements, Section 17E.070.080 Application Submittal Requirements, Section 17G.061.110 Application Requirements, Section 17G.061.120 Determination of a Complete Application, Section 17G.061.130 Application Time Limits, Section 17G.061.150 Modification of Applications and Permits, Section 17G.080.040 Short Subdivisions, Section 17G.080.060 Binding Site Plan, setting an effective date, and other matters properly related thereto. (Council Sponsors: Council Members Bingle, Zappone, and Klitzke)</b></p> | <p><b>Pass<br/>Upon<br/>Roll Call<br/>Vote</b></p> | <p><b>ORD C36596</b></p>    |
| <p><b>H2. a. Hearing for the Citywide Capital Improvement Program for 2025-2030. (Council Sponsors: Council President Wilkerson and Council Members Cathcart and Zappone)</b></p>  | <p><b>Hold<br/>Hrg./<br/>Close<br/>Hrg.</b></p>    | <p><b>FIN 2024-0001</b></p> |
| <p><b>b. Final Reading Ordinance C36598 of the City of Spokane, Washington, adopting a Six-year Citywide Capital Improvement Program for the years 2025 through 2030 and amending the Citywide Capital Improvement Program (CIP) as referenced in Appendix C of the City of Spokane Comprehensive Plan. (Council Sponsors: Council President Wilkerson and Council Members Cathcart and Zappone)</b></p>   | <p><b>Pass<br/>Upon<br/>Roll Call<br/>Vote</b></p> | <p><b>ORD C36598</b></p>    |
| <p><b>H3. a. Hearing on possible revenue sources for the 2025 Budget. (Council Sponsors: Council President Wilkerson and Council Member Zappone)</b></p>   | <p><b>Hold<br/>Hrg./<br/>Close<br/>Hrg.</b></p>    | <p><b>FIN 2024-0001</b></p> |
| <p><b>b. Final Reading Ordinance C36599 updating the Annual City of Spokane property tax levy for 2025. (Council Sponsors: Council President Wilkerson and Council Member Zappone)</b></p>   | <p><b>Pass<br/>Upon<br/>Roll Call<br/>Vote</b></p> | <p><b>ORD C36599</b></p>    |

---

## OPEN FORUM

At the conclusion of legislative business, the Council shall recess briefly and then hold an open public comment period for up to 20 (twenty) speakers, unless a majority of council members vote otherwise. Each speaker is limited to no more than two minutes. In order to participate in Open Forum, you must sign up beginning at 5:00 p.m. on the Friday immediately preceding the legislative session and ending at 6:00 p.m. on the date of the meeting via the virtual testimony form linked in the meeting packet (<https://my.spokanecity.org/citycouncil/documents/>) or in person outside council chambers beginning at 8:00 a.m. on the day of the legislative session. The virtual sign-up form can also be found here: <https://forms.gle/Vd7n381x3seaL1NW6>. (If you are unable to access the form by clicking the hyperlink, please copy and paste the link address into your browser window.) Speakers must sign themselves in using a name. The individuals assigned to the twenty (20) spaces available will be chosen at random, with preference given to individuals who have not spoken at open forum during that calendar month. Instructions for virtual participation are provided on the form when you sign up. The Open Forum is a limited public forum; all matters discussed in the open forum shall relate to the affairs of the City other than items appearing on the Current or Advance Agendas, pending hearing items, and initiatives or referenda in a pending election. Individuals speaking during the open forum shall address their comments to the Council President and shall not use profanity, engage in obscene speech, or make personal comment or verbal insults about any individual.

---

## ADJOURNMENT

The November 4, 2024, Regular Legislative Session of the City Council is adjourned to November 11, 2024.

---

**AMERICANS WITH DISABILITIES ACT (ADA) INFORMATION:** The City of Spokane is committed to providing equal access to its facilities, programs and services for persons with disabilities. The Spokane City Council Chamber in the lower level of Spokane City Hall, 808 W. Spokane Falls Blvd., is wheelchair accessible and also is equipped with an infrared assistive listening system for persons with hearing loss. Headsets may be checked out (upon presentation of picture I.D.) at the City Cable 5 Production Booth located on the First Floor of the Municipal Building, directly above the Chase Gallery or through the meeting organizer. Individuals requesting reasonable accommodations or further information may call, write, or email Risk Management at 509.625.6221, 808 W. Spokane Falls Blvd, Spokane, WA, 99201; or [mlowmaster@spokanecity.org](mailto:mlowmaster@spokanecity.org). Persons who are deaf or hard of hearing may contact Risk Management through the Washington Relay Service at 7-1-1. Please contact us forty-eight (48) hours before the meeting date.

---

## NOTES

**Agenda Sheet for City Council:****Committee:** PIES **Date:** 10/21/2024**Committee Agenda type:** Consent**Date Rec'd**

10/22/2024

**Clerk's File #**

OPR 2024-0924

**Cross Ref #****Project #****Council Meeting Date:** 11/04/2024**Submitting Dept**

FLEET SERVICES

**Bid #****Contact Name/Phone**

RICK GIDDINGS 625-7706

**Requisition #**

RE 20599

**Contact E-Mail**

RGIDDINGS@SPOKANECITY.ORG

**Agenda Item Type**

Purchase w/o Contract

**Council Sponsor(s)**

BWILKERSON JBINGLE KKLITZKE

**Agenda Item Name**

5100 - PURCHASE OF SKID STEER LOADER FOR WASTE TO ENERGY

**Agenda Wording**

Fleet Services would like to purchase a John Deere 316GR Skid Steer Loader for the Waste to Energy facility from Pape Machinery using a SourceWell contract.

**Summary (Background)**

Fleet Services would like to purchase a John Deere 316GR Skid Steer Loader for the Waste to Energy facility from Pape Machinery using a SourceWell contract. This will replace an older unit requiring costly repairs. Total cost including sales tax is \$64,234.67.

Lease? NO

Grant related? NO

Public Works? NO

**Fiscal Impact**

Approved in Current Year Budget? YES

Total Cost \$ 64,234.67

Current Year Cost \$ 64,234.67

Subsequent Year(s) Cost \$ 0

**Narrative**

Quotes were solicited from 3 qualified dealers. Pape was awarded the sale based on unit capability, quality, dealer service, and cost.

**Amount****Budget Account**

Expense \$ 64,234.67

# 4490-44900-94000-56404-99999

Select \$

#

Select \$

#

Select \$

#

\$

#

\$

#



**Continuation of Wording, Summary, Approvals, and Distribution**

**Agenda Wording**

**Summary (Background)**

**Approvals**

<b><u>Dept Head</u></b>	GIDDINGS, RICHARD
<b><u>Division Director</u></b>	BOSTON, MATTHEW
<b><u>Accounting Manager</u></b>	ORLOB, KIMBERLY
<b><u>Legal</u></b>	SCHOEDEL, ELIZABETH
<b><u>For the Mayor</u></b>	PICCOLO, MIKE

**Additional Approvals**

<b><u>PURCHASING</u></b>	PRINCE, THEA

**Distribution List**

	caveryt@spokanecity.org
dpaine@spokanecity.org	tprince@spokanecity.org
atrussell@spokanecity.org	rgiddings@spokanecity.org

## Council Briefing Paper

### Public Infrastructure, Environment & Sustainability Committee

<b>Committee Date</b>	October 21, 2024
<b>Submitting Department</b>	Fleet Services
<b>Contact Name</b>	Rick Giddings
<b>Contact Email &amp; Phone</b>	<a href="mailto:rgiddings@spokanecity.org">rgiddings@spokanecity.org</a> 509-625-7706
<b>Council Sponsor(s)</b>	Wilkerson, Bingle, Klitzke
<b>Select Agenda Item Type</b>	<input checked="" type="checkbox"/> Consent <input type="checkbox"/> Discussion    Time Requested:
<b>Agenda Item Name</b>	5100 – Purchase of Skid Steer Loader for Waste to Energy
<b>Proposed Council Action</b>	<input checked="" type="checkbox"/> Approval to proceed to Legislative Agenda <input type="checkbox"/> Information Only
<b>Summary (Background)</b>	Fleet Services would like to purchase a John Deere 316GR Skid Steer Loader for the Waste to Energy facility from Pape Machinery using a SourceWell contract. This will replace an older unit requiring costly repairs. Total cost including sales tax is \$58,985.
*use the Fiscal Impact box below for relevant financial information	
<b>Fiscal Impact</b>	
<b>Approved in current year budget?</b> <input checked="" type="checkbox"/> Yes <input type="checkbox"/> No <input type="checkbox"/> N/A	
Total Cost: <u>\$58,985</u>	
Current year cost: \$58,985	
Subsequent year(s) cost: \$0	
<b>Narrative:</b> <u>Quotes were solicited from 3 qualified dealers. Pape was awarded the sale based on unit capability, quality, dealer service, and cost.</u>	
<b>Funding Source</b> <input checked="" type="checkbox"/> One-time <input type="checkbox"/> Recurring <input type="checkbox"/> N/A	
Specify funding source: Program revenue	
Is this funding source sustainable for future years, months, etc? Yes	
<b>Expense Occurrence</b> <input checked="" type="checkbox"/> One-time <input type="checkbox"/> Recurring <input type="checkbox"/> N/A	
Other budget impacts: (revenue generating, match requirements, etc.)	
<b>Operations Impacts</b> (If N/A, please give a brief description as to why)	
<ul style="list-style-type: none"> <li>• What impacts would the proposal have on historically excluded communities? None Identified.</li>   <li>• How will data be collected, analyzed, and reported concerning the effect of the program/policy by racial, ethnic, gender identity, national origin, income level, disability, sexual orientation, or other existing disparities? Data will not be collected.</li>   <li>• How will data be collected regarding the effectiveness of this program, policy, or product to ensure it is the right solution? Fleet Services collects lifecycle data for future evaluation.</li> </ul>	

COUNCIL RULES – ATTACHMENT B 1 (STANDARD BRIEFING PAPER)

- Describe how this proposal aligns with current City Policies, including the Comprehensive Plan, Sustainability Action Plan, Capital Improvement Program, Neighborhood Master Plans, Council Resolutions, and others? Aligns with the Centralized Fleet Management Policy

**Council Subcommittee Review**

- Please provide a summary of council subcommittee review. If not reviewed by a council subcommittee, please explain why not. No Subcommittee for this topic.

Quote Id: 31706460

---

Prepared For:  
**CITY OF SPOKANE FLEET**



Prepared By: **REESE DICKINSON**

Pape Machinery, Inc.  
6210 W Rowand Road  
Spokane, WA 99224

Tel: 509-838-5252  
Mobile Phone: 509-995-9858  
Fax: 509-558-2485  
Email: [rdickinson@papemachinery.com](mailto:rdickinson@papemachinery.com)



**Quote Summary**

**Prepared For:**

CITY OF SPOKANE FLEET  
 915 N NELSON ST  
 SPOKANE, WA 99202  
 Business: 509-625-6403  
 TPRINCE@SPOKANECITY.ORG

**Prepared By:**

REESE DICKINSON  
 Pape Machinery, Inc.  
 6210 W Rowand Road  
 Spokane, WA 99224  
 Phone: 509-838-5252  
 Mobile: 509-995-9858  
 rdickinson@papemachinery.com

*This sale is subject to Papé's Terms and Conditions of Sale effective on the date hereof, which are incorporated in full by this reference. The Terms and Conditions of Sale are available at [www.pape.com/terms](http://www.pape.com/terms), and will also be sent by mail or e-mail to the purchaser upon request.*

**Quote Id:** 31706460  
**Created On:** 20 September 2024  
**Last Modified On:** 24 September 2024  
**Expiration Date:** 20 October 2024

<b>Equipment Summary</b>	<b>Selling Price</b>	<b>Qty</b>	<b>Extended</b>
JOHN DEERE 318G Skid Steer	\$ 58,985.00 X	1 =	\$ 58,985.00
<b>Equipment Total</b>			<b>\$ 58,985.00</b>

**Quote Summary**

Equipment Total	\$ 58,985.00
SubTotal	\$ 58,985.00
Sales Tax - (8.90%)	\$ 5,249.67
<b>Total</b>	<b>\$ 64,234.67</b>
Down Payment	(0.00)
Rental Applied	(0.00)
<b>Balance Due</b>	<b>\$ 64,234.67</b>

Salesperson : X \_\_\_\_\_

Accepted By : X \_\_\_\_\_

# Selling Equipment

**MACHINERY**
**Quote Id:** 31706460

**Customer:** CITY OF SPOKANE FLEET

## JOHN DEERE 318G Skid Steer

**Hours:**
**Stock Number:**

				<b>Selling Price</b>
				\$ 58,985.00
<b>Code</b>	<b>Description</b>	<b>Qty</b>	<b>Unit</b>	<b>Extended</b>
0B70P	318G Skid Steer	1	\$ 63,163.00	\$ 63,163.00
<b>Standard Options - Per Unit</b>				
183E	JDLINK™	1	\$ 0.00	\$ 0.00
0202	United States	1	\$ 0.00	\$ 0.00
0259	English Operator's Manual	1	\$ 0.00	\$ 0.00
0351	Translated Text Labels	1	\$ 0.00	\$ 0.00
0505	EH, Cab/Heat/AC, Power Quik-Tatch, SL, 2 Speed, Attachment Performance	1	\$ 5,870.00	\$ 5,870.00
1053	Air Suspension Seat (Cloth with Heat)	1	\$ 684.00	\$ 684.00
1363	3-Inch Seat Belt with Shoulder Harness	1	\$ 290.00	\$ 290.00
4072	Engine - Turbocharged (Yanmar 4TNV86CHT 2.1L meets FT4 Emissions)	1	\$ 0.00	\$ 0.00
5241	10x16.5 10 PR Galaxy Hulk	1	\$ 220.00	\$ 220.00
8047	Counterweight, (Double Set)	1	\$ 819.00	\$ 819.00
8052	Keyless Start (Sealed Switch Module)	1	\$ 437.00	\$ 437.00
8055	Radio, AM/FM with Bluetooth	1	\$ 658.00	\$ 658.00
8057	Rear View Camera	1	\$ 931.00	\$ 931.00
<b>Standard Options Total</b>				<b>\$ 9,909.00</b>
<b>Dealer Attachments</b>				
AT333697	60 in. Dirt Bucket (14.3 cu. ft.) with Edge	1	\$ 1,797.00	\$ 1,797.00
Maxam	Solid Tires	4	\$ 875.00	\$ 3,500.00
<b>Dealer Attachments Total</b>				<b>\$ 5,297.00</b>
<b>Value Added Services Total</b>				<b>\$ 0.00</b>
<b>Suggested Price</b>				<b>\$ 78,369.00</b>
<b>Customer Discounts</b>				
<b>Customer Discounts Total</b>			<b>\$ -19,384.00</b>	<b>\$ -19,384.00</b>
<b>Total Selling Price</b>				<b>\$ 58,985.00</b>



**Agenda Sheet for City Council:**

**Committee:** PIES **Date:** 10/21/2024

**Committee Agenda type:** Consent

**Date Rec'd** 10/22/2024

**Clerk's File #** OPR 2024-0925

**Cross Ref #**

**Project #**

**Council Meeting Date:** 11/04/2024

<b>Submitting Dept</b>	FLEET SERVICES	<b>Bid #</b>	
------------------------	----------------	--------------	--

<b>Contact Name/Phone</b>	RICK GIDDINGS 625-7706	<b>Requisition #</b>	RE20593
---------------------------	------------------------	----------------------	---------

<b>Contact E-Mail</b>	RGIDDINGS@SPOKANECITY.ORG		
-----------------------	---------------------------	--	--

<b>Agenda Item Type</b>	Purchase w/o Contract		
-------------------------	-----------------------	--	--

<b>Council Sponsor(s)</b>	BWILKERSON JBINGLE KKLITZKE		
---------------------------	-----------------------------	--	--

<b>Agenda Item Name</b>	5100 - PURCHASE OF MINI EXCAVATOR FOR WASTE TO ENERGY		
-------------------------	---	--	--

**Agenda Wording**

Fleet Services would like to purchase a John Deere 85P Tier Excavator equipped with a waste grapple, 18" bucket and thumb for the Waste to Energy facility from Pape Machinery using a SourceWell contract.

**Summary (Background)**

Fleet Services would like to purchase a John Deere 85P Tier Excavator equipped with a waste grapple, 18" bucket and thumb for the Waste to Energy facility from Pape Machinery using a SourceWell contract. This will replace a costly rental unit that the department has been testing. Total cost including sales tax is \$171,671.04.

Lease? NO Grant related? NO Public Works? NO

**Fiscal Impact**

Approved in Current Year Budget? YES

Total Cost	\$ 171,671.04
------------	---------------

Current Year Cost	\$
-------------------	----

Subsequent Year(s) Cost	\$
-------------------------	----

**Narrative**

Quotes were solicited from 3 qualified dealers. Pape was awarded the sale based on unit capability, quality, dealer service, and cost.

<b>Amount</b>	<b>Budget Account</b>
---------------	-----------------------

Expense	\$ 171,671.04	# 4492
---------	---------------	--------

Select	\$	#
--------	----	---

Select	\$	#
--------	----	---

Select	\$	#
--------	----	---

	\$	#
--	----	---

	\$	#
--	----	---



**Continuation of Wording, Summary, Approvals, and Distribution**

**Agenda Wording**

**Summary (Background)**

**Approvals**

<b><u>Dept Head</u></b>	GIDDINGS, RICHARD
<b><u>Division Director</u></b>	BOSTON, MATTHEW
<b><u>Accounting Manager</u></b>	ORLOB, KIMBERLY
<b><u>Legal</u></b>	HARRINGTON,
<b><u>For the Mayor</u></b>	PICCOLO, MIKE

**Additional Approvals**

<b><u>PURCHASING</u></b>	PRINCE, THEA

**Distribution List**

	caveryt@spokanecity.org
dpaine@spokanecity.org	tprince@spokanecity.org
atrussell@spokanecity.org	rgiddings@spokanecity.org
fleetservicesaccounting@spokanecity.org	

## Council Briefing Paper

### Public Infrastructure, Environment & Sustainability Committee

<b>Committee Date</b>	October 21, 2024
<b>Submitting Department</b>	Fleet Services
<b>Contact Name</b>	Rick Giddings
<b>Contact Email &amp; Phone</b>	<a href="mailto:rgiddings@spokanecity.org">rgiddings@spokanecity.org</a> 509-625-7706
<b>Council Sponsor(s)</b>	Wilkerson, Bingle, Klitzke
<b>Select Agenda Item Type</b>	<input checked="" type="checkbox"/> Consent <input type="checkbox"/> Discussion    Time Requested:
<b>Agenda Item Name</b>	5100 – Purchase of Mini Excavator for Waste to Energy
<b>Proposed Council Action</b>	<input checked="" type="checkbox"/> Approval to proceed to Legislative Agenda <input type="checkbox"/> Information Only
<b>Summary (Background)</b>	Fleet Services would like to purchase a John Deere 85P Tier Excavator equipped with a waste grapple, 18” bucket and thumb for the Waste to Energy facility from Pape Machinery using a SourceWell contract. This will replace a costly rental unit that the department has been testing. Total cost including sales tax is \$171,671.04.
*use the Fiscal Impact box below for relevant financial information	
<b>Fiscal Impact</b>	
<b>Approved in current year budget?</b> <input checked="" type="checkbox"/> Yes <input type="checkbox"/> No <input type="checkbox"/> N/A	
Total Cost: <u>\$171,671.04</u>	
Current year cost: \$171,671.04	
Subsequent year(s) cost: \$0	
<b>Narrative:</b> <u>Quotes were solicited from 3 qualified dealers. Pape was awarded the sale based on unit capability, quality, dealer service, and cost.</u>	
<b>Funding Source</b> <input checked="" type="checkbox"/> One-time <input type="checkbox"/> Recurring <input type="checkbox"/> N/A	
Specify funding source: Program revenue	
Is this funding source sustainable for future years, months, etc? Yes	
<b>Expense Occurrence</b> <input checked="" type="checkbox"/> One-time <input type="checkbox"/> Recurring <input type="checkbox"/> N/A	
Other budget impacts: (revenue generating, match requirements, etc.)	
<b>Operations Impacts</b> (If N/A, please give a brief description as to why)	
<ul style="list-style-type: none"> <li>• What impacts would the proposal have on historically excluded communities? None Identified.</li>   <li>• How will data be collected, analyzed, and reported concerning the effect of the program/policy by racial, ethnic, gender identity, national origin, income level, disability, sexual orientation, or other existing disparities? Data will not be collected.</li>   <li>• How will data be collected regarding the effectiveness of this program, policy, or product to ensure it is the right solution? Fleet Services collects lifecycle data for future evaluation.</li> </ul>	

COUNCIL RULES – ATTACHMENT B 1 (STANDARD BRIEFING PAPER)

- Describe how this proposal aligns with current City Policies, including the Comprehensive Plan, Sustainability Action Plan, Capital Improvement Program, Neighborhood Master Plans, Council Resolutions, and others? Aligns with the Centralized Fleet Management Policy

**Council Subcommittee Review**

- Please provide a summary of council subcommittee review. If not reviewed by a council subcommittee, please explain why not. No Subcommittee for this topic.

Quote Id: 31526013

---

Prepared For:  
**CITY OF SPOKANE - SPOKANE**



Prepared By: **PETER VAN VOORHIS**

Pape Machinery, Inc.  
6210 W Rowand Road  
Spokane, WA 99224

Tel: 509-838-5252

Fax: 509-558-2485

Email: [pvanvoorhis@papemachinery.com](mailto:pvanvoorhis@papemachinery.com)

Date: 19 August 2024

Offer Expires: 18 September 2024

---

*Confidential*

**Quote Summary**

**Prepared For:**  
 CITY OF SPOKANE - SPOKANE  
 WA

**Prepared By:**  
 PETER VAN VOORHIS  
 Pape Machinery, Inc.  
 6210 W Rowand Road  
 Spokane, WA 99224  
 Phone: 509-838-5252  
 pvanvoorhis@papemachinery.com

*This sale is subject to Papé's Terms and Conditions of Sale effective on the date hereof, which are incorporated in full by this reference. The Terms and Conditions of Sale are available at [www.pape.com/terms](http://www.pape.com/terms), and will also be sent by mail or e-mail to the purchaser upon request.*

**Quote Id:** 31526013  
**Created On:** 19 August 2024  
**Last Modified On:** 23 September 2024  
**Expiration Date:** 18 September 2024

<b>Equipment Summary</b>	<b>Selling Price</b>	<b>Qty</b>	<b>Extended</b>
JOHN DEERE 85 P-Tier Excavator Sourcewell Contract #011723-JDC 33% With Waste Grapple	\$ 157,742.74 X	1 =	\$ 157,742.74
<b>Equipment Total</b>			<b>\$ 157,742.74</b>

**Quote Summary**

Equipment Total	\$ 157,742.74
SubTotal	\$ 157,742.74
Sales Tax - (8.90%)	\$ 13,928.30
Total	\$ 171,671.04
Down Payment	(0.00)
Rental Applied	(0.00)
<b>Balance Due</b>	<b>\$ 171,671.04</b>

Salesperson : X \_\_\_\_\_

Accepted By : X \_\_\_\_\_



# Selling Equipment

Quote Id: 31526013

## JOHN DEERE 85 P-Tier Excavator Sourcewell Contract #011723-JDC 33% With Waste Grapple

Hours:

Stock Number:

Code	Description	Qty
8230FF	85 P EXCAVATOR BASE MACHINE	1
<b>Standard Options - Per Unit</b>		
0202	Destination Code - United States	1
0259	English Customer Delivery Packet	1
0403	Configuration 3	1
<b>Dealer Attachments</b>		
	18" HD Dig Bkt w/Pins-PSM	1
	Hyd PGQC-PSM WL I-Lock (NI)	1
	PSM Hyd Prog Link Thumb-Pin Grabber (NI)	1
	Rotobec 110WG Waste & Recycling Grapple w/RT-222 Rotator and Male Quick adapter plate	1
<b>Other Charges</b>		
	Install-HPGQC	1
	Install-Thumb	1
	After Sales 500 Hour Service	1
	Freight and Delivery	1
	Setup	1
	Install-Arm Aux Line Combo Conv, (HKX)	1
	Rotobech install	1

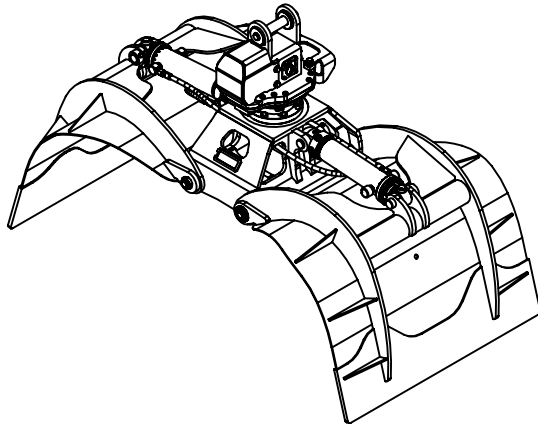

Max load:	- lb	- kg
Volume:	1.10 y <sup>3</sup>	.84 m <sup>3</sup>
Area tip to tip:	5.75 ft <sup>2</sup>	.53 m <sup>2</sup>
Rotator lifting capacity:	22000 lb	9979 kg
Torque at relief pressure:	10700 lb-in 913 psi	1209 Nm 63 bars
Weight:	1195 lb	542 kg

Rotator	Maximum pressure: 5000 psi    345 bars	Recommended flow: 10 gpm    38 l/min
Rotator recommended flow will produce a maximum speed of 30 rpm		

Cylinder	Diameter	Recommended pressure	Pressure range	Flow range	Lock valves
Standard	3 " (76 mm)	3250 psi (224 bars)	2500 - 4000 psi (172-276 bars)	10 - 15 gpm (38-57 l/min.)	No

Grapple cylinder maximum flow will theoretically produce a complete grapple open/close cycle in 4 seconds.

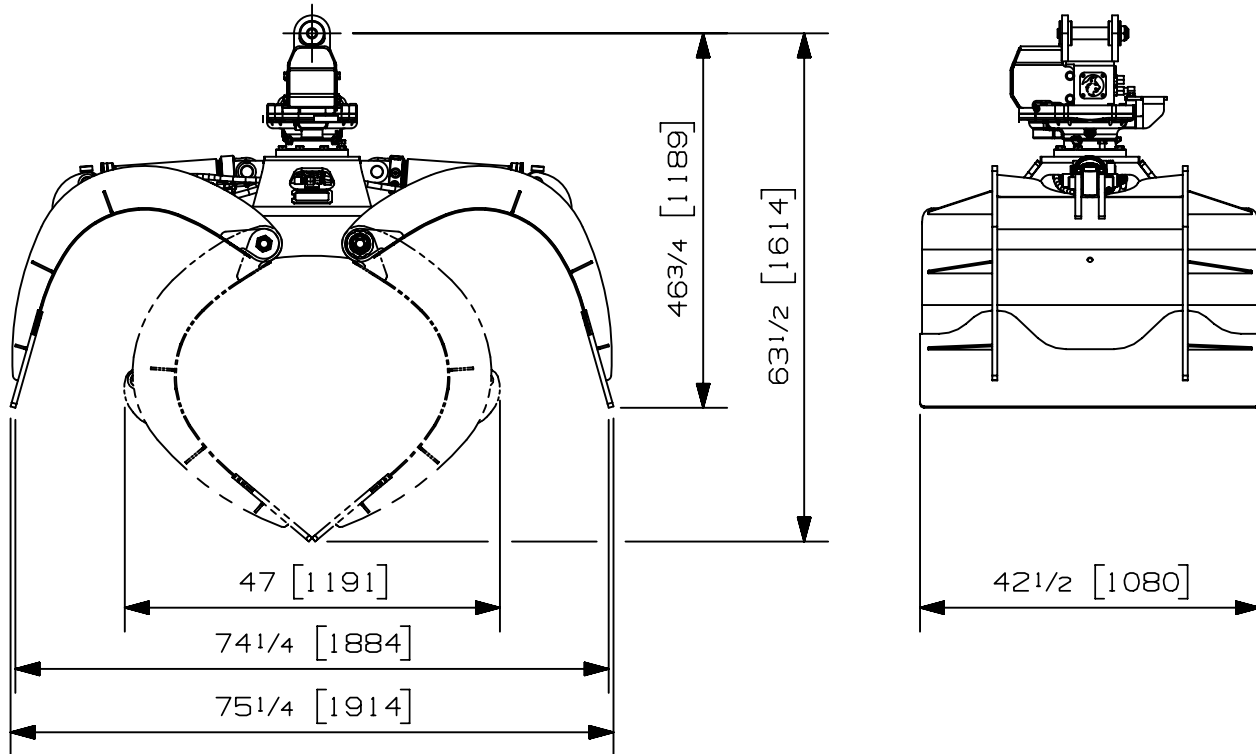

- Options:
- Holding valve
  - 
  - 
  -

web site: [www.rotobec.com](http://www.rotobec.com)

email: [rotobec@rotobec.com](mailto:rotobec@rotobec.com)

**Rotobec Inc.:** Head office serving OEM's and Eastern Canada    Ph: (418) 383-3002 Fax: (418) 383-5334  
**Rotobec West:** Branch serving Western Canada and Western USA    Ph: (250) 765-1161 Fax: (250) 765-0035  
**Rotobec USA:** Branch serving Eastern and Central USA    Ph: (603) 444-2103 Fax: (603) 444-0327

We reserve the right to change specifications and to improve our products without notice or obligation.

07011-5399  
10/11/2022 **J-M.L.**

## Mini Power Attachment PC025T RGP-252

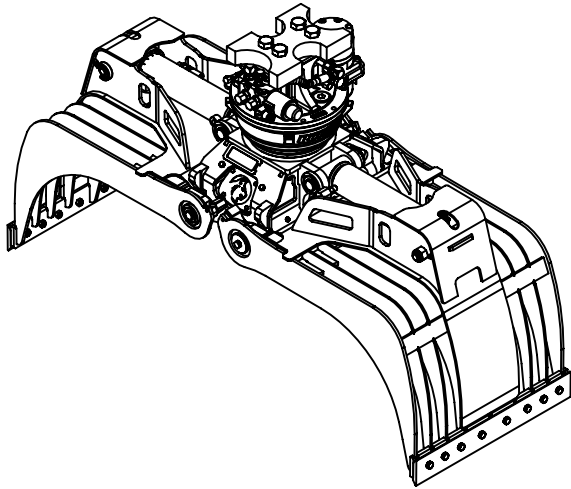

Max load:	- lb	- kg
Volume:	.31 y <sup>3</sup>	.24 m <sup>3</sup>
Area tip to tip:	2.80 ft <sup>2</sup>	.26 m <sup>2</sup>
Rotator lifting capacity:	25000 lb	11340 kg
Torque at relief pressure:	15720 lb-in 913 psi	1776 Nm 63 bars
Weight:	1070 lb	485 kg

Rotator	Maximum pressure: 4200 psi    290 bars	Recommended flow: 10 gpm    38 l/min
Rotator recommended flow will produce a maximum speed of 21 rpm		

Cylinder	Diameter	Recommended pressure	Pressure range	Flow range	Lock valves
Standard	3 " (76 mm)	3700 psi (255 bars)	3200 - 4200 psi (221-290 bars)	9 - 13 gpm (34-49 l/min.)	No

Grapple cylinder maximum flow will theoretically produce a complete grapple open/close cycle in 4 seconds.

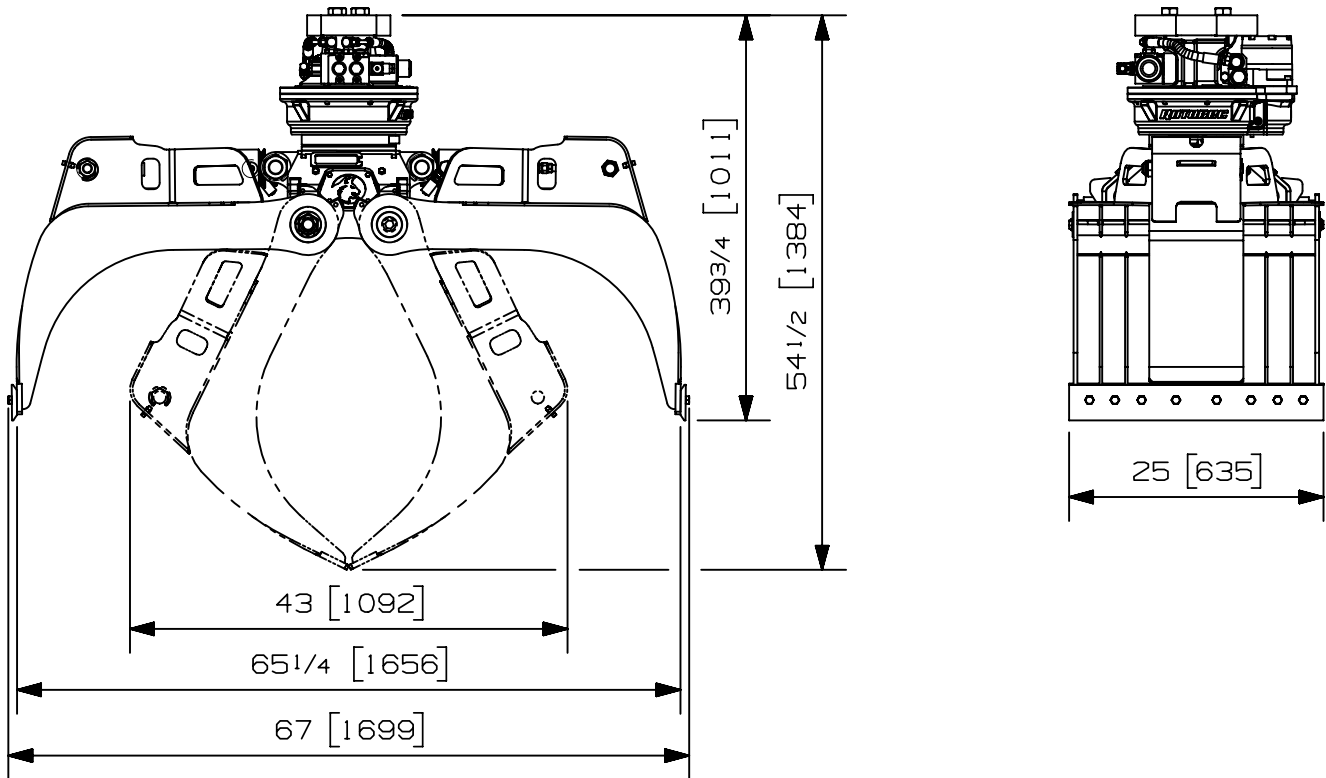

Options:

- See also RGP-252 Option for more options
- 
- 
- 

web site: [www.rotobec.com](http://www.rotobec.com)

email: [rotobec@rotobec.com](mailto:rotobec@rotobec.com)

**Rotobec Inc.:** Head office serving OEM's and Eastern Canada    Ph: (418) 383-3002 Fax: (418) 383-5334  
**Rotobec West:** Branch serving Western Canada and Western USA    Ph: (250) 765-1161 Fax: (250) 765-0035  
**Rotobec USA:** Branch serving Eastern and Central USA    Ph: (603) 444-2103 Fax: (603) 444-0327

We reserve the right to change specifications and to improve our products without notice or obligation.

07011-2125  
14/04/22 M.R.



STATE OF WASHINGTON

# BUSINESS LICENSE

Profit Corporation

PAPE' MACHINERY, INC.  
PAPE MACHINERY INC  
6210 W ROWAND RD  
SPOKANE WA 99224-5321

UNEMPLOYMENT INSURANCE - ACTIVE  
MINOR WORK PERMIT - ACTIVE  
MISCELLANEOUS VEHICLE DEALER SUBAGENCY #06989 - ACTIVE

INDUSTRIAL INSURANCE - ACTIVE  
TAX REGISTRATION - ACTIVE

Issue Date: Mar 22, 2024

Unified Business ID #: 602189602

Business ID #: 001

Location: 0016

Expires: Mar 31, 2025

### CITY/COUNTY ENDORSEMENTS:

- SPOKANE GENERAL BUSINESS - NON-RESIDENT - ACTIVE
- COLVILLE GENERAL BUSINESS - NON-RESIDENT #026960.0 - ACTIVE
- PACIFIC GENERAL BUSINESS - NON-RESIDENT #103475 - ACTIVE

### DUTIES OF MINORS:

Ages 16-17: CLEANING, ORGANIZING, ASSIST WITH PULLING PARTS, CLERICAL DUTIES, PREPARATION AND PRE-DELIVERY SETUP OF EQUIPMENT

### LICENSING RESTRICTIONS:

It is the business's responsibility to comply with minor work permit requirements. See WAC 296-125-030 and WAC 296-125-033 for Non-Agricultural and WAC 296-131-125 for Agricultural guidelines and restricted activities.

Only 17 year olds may drive on public roadways if such driving is occasional and incidental. Restricted to daylight hours. 16 and 17 year olds may occasionally drive on employer's private property. WAC 296-125-030 (2). See L&I's Policy: ES.C.4.3.

Service occupations: if a minor works past 8 p.m., minor must be supervised by a responsible adult employee who is

This document lists the registrations, endorsements, and licenses authorized for the business named above. By accepting this document, the licensee certifies the information on the application was complete, true, and accurate to the best of his or her knowledge, and that business will be conducted in compliance with all applicable Washington state, county, and city regulations.

Director, Department of Revenue

UBI: 602189602 001 0016

PAPE' MACHINERY, INC.  
PAPE MACHINERY INC  
6210 W ROWAND RD  
SPOKANE WA 99224-5321

FOLD HERE

STATE OF WASHINGTON

UNEMPLOYMENT INSURANCE - ACTIVE  
INDUSTRIAL INSURANCE - ACTIVE  
MINOR WORK PERMIT - ACTIVE  
TAX REGISTRATION - ACTIVE  
MISCELLANEOUS VEHICLE DEALER SUBAGENCY #06989 - ACTIVE  
SPOKANE GENERAL BUSINESS - NON-RESIDENT - ACTIVE  
COLVILLE GENERAL BUSINESS - NON-RESIDENT #026960.0 - ACTIVE  
PACIFIC GENERAL BUSINESS - NON-RESIDENT #103475 - ACTIVE

FOLD HERE

Expires: Mar 31, 2025

Director, Department of Revenue



STATE OF WASHINGTON

# BUSINESS LICENSE

Profit Corporation

PAPE' MACHINERY, INC.  
PAPE MACHINERY INC  
6210 W ROWAND RD  
SPOKANE WA 99224-5321  
on the premises at all times. WAC 296-125-030(30)

Issue Date: Mar 22, 2024  
Unified Business ID #: 602189602  
Business ID #: 001  
Location: 0016  
Expires: Mar 31, 2025

REGISTERED TRADE NAMES:  
PAPE MACHINERY INC

This document lists the registrations, endorsements, and licenses authorized for the business named above. By accepting this document, the licensee certifies the information on the application was complete, true, and accurate to the best of his or her knowledge, and that business will be conducted in compliance with all applicable Washington state, county, and city regulations.

Director, Department of Revenue

UBI: 602189602 001 0016

PAPE' MACHINERY, INC.  
PAPE MACHINERY INC  
6210 W ROWAND RD  
SPOKANE WA 99224-5321

FOLD HERE

STATE OF WASHINGTON

FOLD HERE

UNEMPLOYMENT INSURANCE - ACTIVE  
INDUSTRIAL INSURANCE - ACTIVE  
MINOR WORK PERMIT - ACTIVE  
TAX REGISTRATION - ACTIVE  
MISCELLANEOUS VEHICLE DEALER  
SUBAGENCY #06989 - ACTIVE  
SPOKANE GENERAL BUSINESS - NON-RESIDENT - ACTIVE  
COLVILLE GENERAL BUSINESS - NON-RESIDENT #026960.0 - ACTIVE  
PACIFIC GENERAL BUSINESS - NON-RESIDENT #103475 - ACTIVE

Expires: Mar 31, 2025

Director, Department of Revenue

## IMPORTANT!

### PLEASE READ THE FOLLOWING INFORMATION CAREFULLY BEFORE POSTING THIS LICENSE

#### General Information

Post this Business License in a visible location at your place of business.

If you were issued a Business License previously, **destroy the old one and post this one in its place.**

Login to My DOR at [dor.wa.gov](http://dor.wa.gov) if you need to make changes to your business name, location, mailing address, telephone number, or business ownership.

Telephone: 360-705-6741

#### Endorsements

All endorsements should be renewed by the expiration date that appears on the front of this license to avoid any late fees.

If there is no expiration date, the endorsements remain active as long as you continue required reporting. Tax Registration, Unemployment Insurance, and Industrial Insurance endorsements require you to submit periodic reports. Each agency will send you the necessary reporting forms and instructions.

For assistance or to request this document in an alternate format, visit <http://business.wa.gov/BLS> or call (360) 705-6741. Teletype (TTY) users may use the Washington Relay Service by calling 711.

BLS-700-107 (07/27/20)



**Agenda Sheet for City Council:**

**Committee:** PIES **Date:** 10/21/2024

**Committee Agenda type:** Consent

**Date Rec'd** 10/22/2024

**Clerk's File #** OPR 2023-1095

**Cross Ref #**

**Project #**

**Council Meeting Date:** 11/04/2024

<b>Submitting Dept</b>	FLEET SERVICES	<b>Bid #</b>	
------------------------	----------------	--------------	--

<b>Contact Name/Phone</b>	RICK GIDDINGS 625-7706	<b>Requisition #</b>	CR26799
---------------------------	------------------------	----------------------	---------

<b>Contact E-Mail</b>	RGIDDINGS@SPOKANECITY.ORG		
-----------------------	---------------------------	--	--

<b>Agenda Item Type</b>	Contract Item		
-------------------------	---------------	--	--

<b>Council Sponsor(s)</b>	BWILKERSON JBINGLE KKLITZKE		
---------------------------	-----------------------------	--	--

<b>Agenda Item Name</b>	5100 - CLEAN ENERGY CONTRACT EXTENSION		
-------------------------	--	--	--

**Agenda Wording**

Fleet Services would like to extend our contract with Clean Energy Inc. for the maintenance and repair of Solid Waste Collection's CNG Fueling Site. Contract cost is based on quantity of fuel dispensed at the site but is not to exceed \$250k.

**Summary (Background)**

Fleet Services would like to extend our contract with Clean Energy Inc. for the maintenance and repair of Solid Waste Collection's Compressed Natural Gas Fueling Site. Contract cost is based on quantity of fuel dispensed at the site but is not to exceed \$250,000 per year. This will be the first of 4 extensions.

Lease? NO Grant related? NO Public Works? NO

**Fiscal Impact**

Approved in Current Year Budget? YES

Total Cost	\$ 250,000.00
------------	---------------

Current Year Cost	\$ 250,000.00
-------------------	---------------

Subsequent Year(s) Cost	\$ 250,000.00
-------------------------	---------------

**Narrative**

The original contract was competed via an RFP. Clean Energy was the only qualified submitter.

**Amount**

**Budget Account**

Expense	\$ 250,000.00	# 5100-71600-48348-54201-55681
Select	\$	#
Select	\$	#
Select	\$	#
	\$	#
	\$	#



**Continuation of Wording, Summary, Approvals, and Distribution**

**Agenda Wording**

**Summary (Background)**

**Approvals**

<b><u>Dept Head</u></b>	GIDDINGS, RICHARD
<b><u>Division Director</u></b>	BOSTON, MATTHEW
<b><u>Accounting Manager</u></b>	ORLOB, KIMBERLY
<b><u>Legal</u></b>	HARRINGTON,
<b><u>For the Mayor</u></b>	PICCOLO, MIKE

**Additional Approvals**

<b><u>PURCHASING</u></b>	PRINCE, THEA

**Distribution List**

chad.lindholm@cleanenergyfuels.com	rhughes@spokanecity.org
rgiddings@spokanecity.org	tprince@spokanecity.org
atrussell@spokanecity.org	



## Council Briefing Paper

### Public Infrastructure, Environment & Sustainability Committee

<b>Committee Date</b>	October 21, 2024
<b>Submitting Department</b>	Fleet Services
<b>Contact Name</b>	Rick Giddings
<b>Contact Email &amp; Phone</b>	<a href="mailto:rgiddings@spokanecity.org">rgiddings@spokanecity.org</a> 509-625-7706
<b>Council Sponsor(s)</b>	Wilkerson, Bingle, Klitzke
<b>Select Agenda Item Type</b>	<input checked="" type="checkbox"/> Consent <input type="checkbox"/> Discussion    Time Requested:
<b>Agenda Item Name</b>	5100 – Clean Energy Contract Extension 1 of 4
<b>Proposed Council Action</b>	<input checked="" type="checkbox"/> Approval to proceed to Legislative Agenda <input type="checkbox"/> Information Only
<b>Summary (Background)</b>	Fleet Services would like to extend our contract with Clean Energy Inc. for the maintenance and repair of Solid Waste Collection’s Compressed Natural Gas Fueling Site. Contract cost is based on quantity of fuel dispensed at the site but is not to exceed \$250,000 per year. This will be the first of 4 extensions.
*use the Fiscal Impact box below for relevant financial information	
<b>Fiscal Impact</b>	
<b>Approved in current year budget?</b> <input checked="" type="checkbox"/> Yes <input type="checkbox"/> No <input type="checkbox"/> N/A Total Cost: <u>\$250,000</u> Current year cost: \$250,000 Subsequent year(s) cost: \$0	
<b>Narrative:</b> <u>The original contract was competed via an RFP. Clean Energy was the only qualified submitter.</u>	
<b>Funding Source</b> <input checked="" type="checkbox"/> One-time <input type="checkbox"/> Recurring <input type="checkbox"/> N/A Specify funding source: Program revenue Is this funding source sustainable for future years, months, etc? Yes	
<b>Expense Occurrence</b> <input checked="" type="checkbox"/> One-time <input type="checkbox"/> Recurring <input type="checkbox"/> N/A  Other budget impacts: (revenue generating, match requirements, etc.)	
<b>Operations Impacts</b> (If N/A, please give a brief description as to why)	
<ul style="list-style-type: none"> <li>• What impacts would the proposal have on historically excluded communities? None Identified.</li> <li>• How will data be collected, analyzed, and reported concerning the effect of the program/policy by racial, ethnic, gender identity, national origin, income level, disability, sexual orientation, or other existing disparities? Data will not be collected.</li> <li>• How will data be collected regarding the effectiveness of this program, policy, or product to ensure it is the right solution? Fleet Services collects lifecycle data for future evaluation.</li> </ul>	

COUNCIL RULES – ATTACHMENT B 1 (STANDARD BRIEFING PAPER)

- Describe how this proposal aligns with current City Policies, including the Comprehensive Plan, Sustainability Action Plan, Capital Improvement Program, Neighborhood Master Plans, Council Resolutions, and others? Aligns with the Centralized Fleet Management Policy

**Council Subcommittee Review**

- Please provide a summary of council subcommittee review. If not reviewed by a council subcommittee, please explain why not. No Subcommittee for this topic.



**City of Spokane**  
**CONTRACT RENEWAL #1 of 4**  
Title: **OPERATION AND MAINTENANCE  
SERVICES FOR CNG SITE**

This Contract Renewal is made and entered into by and between the **CITY OF SPOKANE** as ("City"), a Washington municipal corporation, and **CLEAN ENERGY dba CLEAN ENERGY CORP.**, whose address is 4675 MacArthur Court, Suite 800, Newport Beach, California 92660 as ("Contractor"), individually hereafter referenced as a "Party", and together as the "Parties".

*WHEREAS, the parties entered into a Contract wherein the Contractor agreed to provide Operation and Maintenance Services for the CNG Site, which is stated in the Contractor's September 15, 2023 Proposal attached to the original contract; and*

*WHEREAS, the initial contract provided for four (4) additional one (1) year renewals, with this being the first of those renewals;*

*-- NOW, THEREFORE, in consideration of these terms, the parties mutually agree as follows:*

**1. CONTRACT DOCUMENTS.**

The original Contract, dated December 18, 2023, and December 19, 2023, any previous amendment, renewals and / or extensions / thereto, are incorporated by reference into this document as though written in full and shall remain in full force and effect except as provided herein.

**2. EFFECTIVE DATE.**

This Contract Renewal shall become effective on October 1, 2024, and shall end September 30, 2025.

**3. COMPENSATION.**

The City shall pay an estimated maximum annual cost not to exceed **TWO HUNDRED FIFTY THOUSAND AND 00/100 (\$250,000.00)**, plus sales tax if applicable, for everything furnished and done under this Contract Renewal. This is the maximum amount to be paid under this Renewal, and shall not be exceeded without the prior written authorization of the City, memorialized with the same formality as the original Contract and this Renewal document.

**4. DEBARMENT AND SUSPENSION.**

The Contractor has provided its certification that it is in compliance with and shall not contract with individuals or organizations which are debarred, suspended, or otherwise excluded from or ineligible from participation in Federal Assistance Programs under Executive Order 12549 and "Debarment and Suspension", codified at 29 CFR part 98.

IN WITNESS WHEREOF, in consideration of the terms, conditions and covenants contained, or attached and incorporated and made a part, the parties have executed this Contract Renewal by having legally-binding representatives affix their signatures below.

**CLEAN ENERGY dba CLEAN ENERGY CORP. CITY OF SPOKANE**

By \_\_\_\_\_  
Signature Date

By \_\_\_\_\_  
Signature Date

\_\_\_\_\_  
Type or Print Name

\_\_\_\_\_  
Type or Print Name

\_\_\_\_\_  
Title

\_\_\_\_\_  
Title

Attest:

Approved as to form:

\_\_\_\_\_  
City Clerk

\_\_\_\_\_  
Assistant City Attorney

**Attachments that are part of this Agreement:**

Certificate of Debarment

24-209

**ATTACHMENT A**

**CERTIFICATION REGARDING DEBARMENT, SUSPENSION,  
INELIGIBILITY AND VOLUNTARY EXCLUSION**

1. The undersigned (i.e., signatory for the Subrecipient / Contractor / Consultant) certifies, to the best of its knowledge and belief, that it and its principals:
  - a. Are not presently debarred, suspended, proposed for debarment, declared ineligible, or voluntarily excluded from covered transactions by any federal department or agency;
  - b. Have not within a three-year period preceding this contract been convicted or had a civil judgment rendered against them for commission of fraud or a criminal offense in connection with obtaining, attempting to obtain, or performing a public (federal, state, or local) transaction or contract under a public transaction; violation of federal or state antitrust statutes or commission of embezzlement, theft, forgery, bribery, falsification or destruction of records, making false statements, tax evasion, receiving stolen property, making false claims, or obstruction of justice;
  - c. Are not presently indicted or otherwise criminally or civilly charged by a government entity (federal, state, or local) with commission of any of the offenses enumerated in paragraph (1)(b) of this certification; and,
  - d. Have not within a three-year period preceding this contract had one or more public transactions (federal, state, or local) terminated for cause or default.
  
2. The undersigned agrees by signing this contract that it shall not knowingly enter into any lower tier covered transaction with a person who is debarred, suspended, declared ineligible, or voluntarily excluded from participation in this covered transaction.
  
3. The undersigned further agrees by signing this contract that it will include the following clause, without modification, in all lower tier covered transactions and in all solicitations for lower tier covered transactions:

Certification Regarding Debarment, Suspension, Ineligibility and Voluntary Exclusion – Lower Tier Covered Transactions

1. The lower tier contractor certified, by signing this contract that neither it nor its principals is presently debarred, suspended, proposed for debarment, declared ineligible, or voluntarily excluded from participation in this transaction by any federal department or agency.
  
  2. Where the lower tier contractor is unable to certify to any of the statements in this contract, such contractor shall attach an explanation to this contract.
4. I understand that a false statement of this certification may be grounds for termination of the contract.

<hr/> Name of Subrecipient / Contractor / Consultant (Type or Print)	<hr/> Program Title (Type or Print)
<hr/> Name of Certifying Official (Type or Print)	<hr/> Signature
<hr/> Title of Certifying Official (Type or Print)	<hr/> Date (Type or Print)



STATE OF WASHINGTON  
**BUSINESS LICENSING SERVICE**

**Thank you for renewing online**

Your license renewal has been submitted. Please print this receipt for your records and allow 14 days to receive your new business license document in the mail.

**Previous Expiration Date:** Dec-31-2023

**New Expiration Date:** Dec-31-2024

**Confirmation Number:** 0-037-293-893

**Filing Date and Time:** 12/30/2023 02:39:31 PM

**Payment Method:** Bank Account

**Business Entity Information**

Legal Entity Name: CLEAN ENERGY DBA CLEAN ENERGY CORP.

Account ID: 602224232-001-0004

**Business Location Information**

Location Name: CLEAN ENERGY CORP.

Business Phone: (949) 437-1049

Business Fax: (949) 743-5060

Location Address: 4675 MACARTHUR CT STE 800 NEWPORT BEACH CA 92660-1895

Mailing Address: 4675 MACARTHUR CT STE 800 NEWPORT BEACH CA 92660-1895

Endorsement(s)	Begin	End	Count	Fee
Spokane General Business - Non-Resident	01/01/2024	12/31/2024	1	\$0.00
				<hr/>
				<b>\$0.00</b>

Fee Type	Begin	End	Count	Fee
BLS Processing Fee	01/01/2024		1	\$5.00
				<hr/>
				<b>\$5.00</b>

**Grand Total: \$5.00**

110-356-20369-700210

*Sally Guan* 12.30.23



CERTIFICATE OF LIABILITY INSURANCE

DATE (MM/DD/YYYY)
11/28/2023

THIS CERTIFICATE IS ISSUED AS A MATTER OF INFORMATION ONLY AND CONFERS NO RIGHTS UPON THE CERTIFICATE HOLDER. THIS CERTIFICATE DOES NOT AFFIRMATIVELY OR NEGATIVELY AMEND, EXTEND OR ALTER THE COVERAGE AFFORDED BY THE POLICIES BELOW.

IMPORTANT: If the certificate holder is an ADDITIONAL INSURED, the policy(ies) must have ADDITIONAL INSURED provisions or be endorsed. If SUBROGATION IS WAIVED, subject to the terms and conditions of the policy, certain policies may require an endorsement.

PRODUCER License # 0757776
HUB International Insurance Services Inc.
4695 MacArthur Court
Suite 600
Newport Beach, CA 92660
CONTACT NAME: Kimberly Shippey
PHONE (A/C, No, Ext):
FAX (A/C, No):
E-MAIL ADDRESS: kimberly.shippey@hubinternational.com
INSURER(S) AFFORDING COVERAGE
INSURER A: Federal Insurance Company
INSURER B: Pacific Indemnity Company
INSURER C:
INSURER D:
INSURER E:
INSURER F:

COVERAGES CERTIFICATE NUMBER: REVISION NUMBER:

THIS IS TO CERTIFY THAT THE POLICIES OF INSURANCE LISTED BELOW HAVE BEEN ISSUED TO THE INSURED NAMED ABOVE FOR THE POLICY PERIOD INDICATED. NOTWITHSTANDING ANY REQUIREMENT, TERM OR CONDITION OF ANY CONTRACT OR OTHER DOCUMENT WITH RESPECT TO WHICH THIS CERTIFICATE MAY BE ISSUED OR MAY PERTAIN, THE INSURANCE AFFORDED BY THE POLICIES DESCRIBED HEREIN IS SUBJECT TO ALL THE TERMS, EXCLUSIONS AND CONDITIONS OF SUCH POLICIES. LIMITS SHOWN MAY HAVE BEEN REDUCED BY PAID CLAIMS.

Table with columns: INSR LTR, TYPE OF INSURANCE, ADDL INSD, SUBR WVD, POLICY NUMBER, POLICY EFF (MM/DD/YYYY), POLICY EXP (MM/DD/YYYY), LIMITS. Rows include Commercial General Liability, Automobile Liability, Umbrella Liab, and Workers Compensation.

DESCRIPTION OF OPERATIONS / LOCATIONS / VEHICLES (ACORD 101, Additional Remarks Schedule, may be attached if more space is required)
RE: Maintenance Services Agmt at 915 North Nelson Street, Spokane, WA 99202 (Site #20369)
City of Spokane, its officers and employees are additional insured as respects general liability and auto liability, as required by written contract, subject to the terms and conditions of the policy and attached forms.
Excess liability is following form. Separation of Insureds applies. 30 day notice of cancellation, except 10 days for non-payment.

CERTIFICATE HOLDER: City of Spokane, 915 North Nelson, Spokane, WA 99202
CANCELLATION: SHOULD ANY OF THE ABOVE DESCRIBED POLICIES BE CANCELLED BEFORE THE EXPIRATION DATE THEREOF, NOTICE WILL BE DELIVERED IN ACCORDANCE WITH THE POLICY PROVISIONS.
AUTHORIZED REPRESENTATIVE: [Signature]

**Liability Insurance**

**Endorsement**

*Policy Period*                      NOVEMBER 30 2023 TO NOVEMBER 30 2024

*Policy Number*                    3581-68-98DAL

*Insured*                                CLEAN ENERGY A CA CORPORATION

*Name of Company*                FEDERAL INSURANCE COMPANY

This Endorsement applies to the following forms:

GENERAL LIABILITY

Under Who Is An Insured, the following provision is added:

**Who Is An Insured**

**Designated Persons Or Organizations**

Any person or organization designated below is an **insured**; but they are **insureds** only with respect to their liability arising out of your acts or failure to act.

Designated Insured

"ANY PERSON OR ORGANIZATION BUT ONLY TO THE EXTENT SPECIFIED UNDER WRITTEN CONTRACT, AGREEMENT OR PERMIT SIGNED PRIOR TO THE DATE OF AN OCCURRENCE COVERED BY THIS POLICY."

All other terms and conditions remain unchanged.

Authorized Representative





**THIS ENDORSEMENT CHANGES THE POLICY. PLEASE READ IT CAREFULLY.**

## COMMERCIAL AUTOMOBILE BROAD FORM ENDORSEMENT

This endorsement modifies insurance provided under the following:

### BUSINESS AUTO COVERAGE FORM

This endorsement modifies the Business Auto Coverage Form.

#### 1. EXTENDED CANCELLATION CONDITION

Paragraph A.2.b. - CANCELLATION - of the COMMON POLICY CONDITIONS form IL 00 17 is deleted and replaced with the following:

- b. 60 days before the effective date of cancellation if we cancel for any other reason.

#### 2. BROAD FORM INSURED

##### A. Subsidiaries and Newly Acquired or Formed Organizations As Insureds

The Named Insured shown in the Declarations is amended to include:

1. Any legally incorporated subsidiary in which you own more than 50% of the voting stock on the effective date of the Coverage Form. However, the Named Insured does not include any subsidiary that is an "insured" under any other automobile policy or would be an "insured" under such a policy but for its termination or the exhaustion of its Limit of Insurance.
2. Any organization that is acquired or formed by you and over which you maintain majority ownership. However, the Named Insured does not include any newly formed or acquired organization:
  - (a) That is an "insured" under any other automobile policy;
  - (b) That has exhausted its Limit of Insurance under any other policy; or
  - (c) 180 days or more after its acquisition or formation by you, unless you have given us written notice of the acquisition or formation.

Coverage does not apply to "bodily injury" or "property damage" that results from an "accident" that occurred before you formed or acquired the organization.

##### B. Employees as Insureds

Paragraph A.1. - WHO IS AN INSURED - of SECTION II - LIABILITY COVERAGE is amended to add the following:

- d. Any "employee" of yours while using a covered "auto" you don't own, hire or

borrow in your business or your personal affairs.

#### C. Lessors as Insureds

Paragraph A.1. - WHO IS AN INSURED - of SECTION II - LIABILITY COVERAGE is amended to add the following:

- e. The lessor of a covered "auto" while the "auto" is leased to you under a written agreement if:
  - (1) The agreement requires you to provide direct primary insurance for the lessor; and
  - (2) The "auto" is leased without a driver. Such leased "auto" will be considered a covered "auto" you own and not a covered "auto" you hire. However, the lessor is an "insured" only for "bodily injury" or "property damage" resulting from the acts or omissions by:
    1. You;
    2. Any of your "employees" or agents; or
    3. Any person, except the lessor or any "employee" or agent of the lessor, operating an "auto" with the permission of any of 1. and/or 2. above.

#### D. Persons And Organizations As Insureds Under A Written Insured Contract

Paragraph A.1 - WHO IS AN INSURED - of SECTION II - LIABILITY COVERAGE is amended to add the following:

- f. Any person or organization with respect to the operation, maintenance or use of a covered "auto", provided that you and such person or organization have agreed under an express provision in a written "insured contract", written agreement or a written permit issued to you by a governmental or public authority to add such person or organization to this policy as an "insured". However, such person or organization is an "insured" only:

- (1) with respect to the operation, maintenance or use of a covered "auto"; and
- (2) for "bodily injury" or "property damage" caused by an "accident" which takes place after:
  - (a) You executed the "insured contract" or written agreement; or
  - (b) The permit has been issued to you.

**3. FELLOW EMPLOYEE COVERAGE**

EXCLUSION B.5. - FELLOW EMPLOYEE - of SECTION II - LIABILITY COVERAGE does not apply.

**4. PHYSICAL DAMAGE - ADDITIONAL TEMPORARY TRANSPORTATION EXPENSE COVERAGE**

Paragraph A.4.a. - TRANSPORTATION EXPENSES - of SECTION III - PHYSICAL DAMAGE COVERAGE is amended to provide a limit of \$50 per day for temporary transportation expense, subject to a maximum limit of \$1,000.

**5. AUTO LOAN/LEASE GAP COVERAGE**

Paragraph A. 4. - COVERAGE EXTENSIONS - of SECTION III - PHYSICAL DAMAGE COVERAGE is amended to add the following:

**c. Unpaid Loan or Lease Amounts**

In the event of a total "loss" to a covered "auto", we will pay any unpaid amount due on the loan or lease for a covered "auto" minus:

- 1. The amount paid under the Physical Damage Coverage Section of the policy; and
- 2. Any:
  - a. Overdue loan/lease payments at the time of the "loss";
  - b. Financial penalties imposed under a lease for excessive use, abnormal wear and tear or high mileage;
  - c. Security deposits not returned by the lessor;
  - d. Costs for extended warranties, Credit Life Insurance, Health, Accident or Disability Insurance purchased with the loan or lease; and
  - e. Carry-over balances from previous loans or leases.

We will pay for any unpaid amount due on the loan or lease if caused by:

- 1. Other than Collision Coverage only if the Declarations indicate that Comprehensive Coverage is provided for any covered "auto";
- 2. Specified Causes of Loss Coverage only if the Declarations indicate that Specified Causes of Loss Coverage is provided for any covered "auto"; or
- 3. Collision Coverage only if the Declarations indicate that Collision Coverage is provided for any covered "auto".

**6. RENTAL AGENCY EXPENSE**

Paragraph A. 4. - COVERAGE EXTENSIONS - of SECTION III - PHYSICAL DAMAGE COVERAGE is amended to add the following:

**d. Rental Expense**

We will pay the following expenses that you or any of your "employees" are legally obligated to pay because of a written contract or agreement entered into for use of a rental vehicle in the conduct of your business:

MAXIMUM WE WILL PAY FOR ANY ONE CONTRACT OR AGREEMENT:

- 1. \$2,500 for loss of income incurred by the rental agency during the period of time that vehicle is out of use because of actual damage to, or "loss" of, that vehicle, including income lost due to absence of that vehicle for use as a replacement;
- 2. \$2,500 for decrease in trade-in value of the rental vehicle because of actual damage to that vehicle arising out of a covered "loss"; and
- 3. \$2,500 for administrative expenses incurred by the rental agency, as stated in the contract or agreement.
- 4. \$7,500 maximum total amount for paragraphs 1., 2. and 3. combined.

**7. EXTRA EXPENSE - BROADENED COVERAGE**

Paragraph A.4. - COVERAGE EXTENSIONS - of SECTION III - PHYSICAL DAMAGE COVERAGE is amended to add the following:

**e. Recovery Expense**

We will pay for the expense of returning a stolen covered "auto" to you.

**8. AIRBAG COVERAGE**

Paragraph B.3.a. - EXCLUSIONS - of SECTION III - PHYSICAL DAMAGE COVERAGE does not apply to the accidental or unintended discharge of an airbag. Coverage is excess over any other collectible insurance or warranty specifically designed to provide this coverage.

**9. AUDIO, VISUAL AND DATA ELECTRONIC EQUIPMENT - BROADENED COVERAGE**

Paragraph C.1.b. - LIMIT OF INSURANCE - of SECTION III - PHYSICAL DAMAGE is deleted and replaced with the following:

- b. \$2,000 is the most we will pay for "loss" in any one "accident" to all electronic equipment that reproduces, receives or transmits audio, visual or data signals which, at the time of "loss", is:
  - (1) Permanently installed in or upon the covered "auto" in a housing, opening or other location that is not normally used by the "auto" manufacturer for the installation of such equipment;
  - (2) Removable from a permanently installed housing unit as described in Paragraph 2.a. above or is an integral part of that equipment; or
  - (3) An integral part of such equipment.

**10. GLASS REPAIR-WAIVER OF DEDUCTIBLE**

Under Paragraph D. - DEDUCTIBLE - of SECTION III - PHYSICAL DAMAGE COVERAGE the following is added:

No deductible applies to glass damage if the glass is repaired rather than replaced.

#### 11. TWO OR MORE DEDUCTIBLES

Paragraph D.- DEDUCTIBLE - of SECTION III - PHYSICAL DAMAGE COVERAGE is amended to add the following:

If this Coverage Form and any other Coverage Form or policy issued to you by us that is not an automobile policy or Coverage Form applies to the same "accident", the following applies:

1. If the deductible under this Business Auto Coverage Form is the smaller (or smallest) deductible, it will be waived; or
2. If the deductible under this Business Auto Coverage Form is not the smaller (or smallest) deductible, it will be reduced by the amount of the smaller (or smallest) deductible.

#### 12. AMENDED DUTIES IN THE EVENT OF ACCIDENT, CLAIM, SUIT OR LOSS

Paragraph A.2.a. - DUTIES IN THE EVENT OF AN ACCIDENT, CLAIM, SUIT OR LOSS of SECTION IV - BUSINESS AUTO CONDITIONS is deleted and replaced with the following:

a. In the event of "accident», claim, "suit" or "loss", you must promptly notify us when the "accident" is known to:

- (1) You or your authorized representative, if you are an individual;
- (2) A partner, or any authorized representative, if you are a partnership;
- (3) A member, if you are a limited liability company; or
- (4) An executive officer, insurance manager, or authorized representative, if you are an organization other than a partnership or limited liability company.

Knowledge of an "accident", claim, "suit" or "loss" by other persons does not imply that the persons listed above have such knowledge.

Notice to us should include:

- (1) How, when and where the "accident" or "loss" occurred;
- (2) The "insured's" name and address; and
- (3) To the extent possible, the names and addresses of any injured persons or witnesses.

#### 13. WAIVER OF SUBROGATION

Paragraph A.5. - TRANSFER OF RIGHTS OF RECOVERY AGAINST OTHERS TO US of SECTION IV - BUSINESS AUTO CONDITIONS is deleted and replaced with the following:

5. We will waive the right of recovery we would otherwise have against another person or organization for "loss" to which this insurance applies, provided the "insured" has waived

their rights of recovery against such person or organization under a contract or agreement that is entered into before such "loss".

To the extent that the "insured's" rights to recover damages for all or part of any payment made under this insurance has not been waived, those rights are transferred to us. That person or organization must do everything necessary to secure our rights and must do nothing after "accident" or "loss" to impair them. At our request, the insured will bring suit or transfer those rights to us and help us enforce them.

#### 14. UNINTENTIONAL FAILURE TO DISCLOSE HAZARDS

Paragraph B.2. - CONCEALMENT, MISREPRESENTATION or FRAUD of SECTION IV- BUSINESS AUTO CONDITIONS - is deleted and replaced with the following:

If you unintentionally fail to disclose any hazards existing at the inception date of your policy, we will not void coverage under this Coverage Form because of such failure.

#### 15. AUTOS RENTED BY EMPLOYEES

Paragraph B.5. - OTHER INSURANCE of SECTION IV - BUSINESS AUTO CONDITIONS - is amended to add the following:

e. Any "auto" hired or rented by your "employee" on your behalf and at your direction will be considered an "auto" you hire. If an "employee's" personal insurance also applies on an excess basis to a covered "auto" hired or rented by your "employee" on your behalf and at your direction, this insurance will be primary to the "employee's" personal insurance.

#### 16. HIRED AUTO - COVERAGE TERRITORY

Paragraph B.7.b.(5). - POLICY PERIOD, COVERAGE TERRITORY of SECTION IV - BUSINESS AUTO CONDITIONS is deleted and replaced with the following:

- (5) A covered "auto" of the private passenger type is leased, hired, rented or borrowed without a driver for a period of 45 days or less; and

#### 17. RESULTANT MENTAL ANGUISH COVERAGE

Paragraph C. of - SECTION V - DEFINITIONS is deleted and replaced by the following:

"Bodily injury" means bodily injury, sickness or disease sustained by any person, including mental anguish or death as a result of the "bodily injury" sustained by that person.

CITY OF SPOKANE OFFICE OF THE CITY ATTORNEY  
**CONTRACT REQUEST FORM**

Requesting Department: Fleet Services

Contact Person: Thea Prince

SME: Rick Giddings

Type of Contract:  New Contract

Renewal

Amendment

Extension

What work or service is being provided: Operation and Maintenance Service for CNG Site

If Request Is For Amendment, Renewal or Extension, Provide OPR #: 2023-1095

Contractor/Consultant Name: Clean Energy dba Clean Energy Corp

Contractor/Consultant Address: 4675 Macarthur Ct., Ste 800, Newport Beach, CA  
92660-1895

Contract Begin Date: 10/1/24

Contract End Date: 9/30/25

Dollar Amount of Contract (Provide Breakdown Of Costs If Applicable): Not to exceed  
\$250,000.00 not including sales tax if applicable

Does Dollar Amount of Contract Include Sales Tax?  YES  NO

Funding Sources (e.g., CD, Dept. of Justice, Etc.): Dept

Federal Funding (DWSRF, CWSRF, WSDOT, FHWA, Etc.): N/A

Was The Contractor / Consultant Solicited by City's Request For Proposal / Quote / Bid?

If Yes, Provide City's Specifications And / Or City's Request for Proposals.

If Yes, Provide Copy of the Consultant's Proposal / Contractor's Bid / Quote.

If No, Provide Scope Of Work To Be Performed By The Consultant / Contractor.

If No, Provide Sole Source Justification Form For Contracts Greater Than \$10,000.

**\*\*\*REQUIRED ATTACHMENTS\*\*\***

Certificate of Insurance

Business License

Method of Procurement

Chosen from MRSC Roster? YES  NO

If not chosen from MRSC Roster, how chosen? \_\_\_\_\_

(Not required on Service contracts under \$10,000.00, but encouraged, and good to  
reference on contract.) \*\* Required On All Public Work/Prevailing Wage Contracts.

Invoice / Bid / Proposal / Quote

Sole Source Justification Form

Standardized Justification Form

**\*\*\*CONTRACT AMENDMENTS\*\*\***

Provide Reason For Amendment.

Provide Desired Changes In Contract Wording.

**NOTES:** Extension #1 of 4

---

---

**\*\*\*ONLY IF THIS IS A PUBLIC WORKS CONTRACT REQUEST\*\*\***

**Prevailing Wages:**

Did The City's Request For Quote / Bid Require Payment of Prevailing Wages By The Contractor?  Yes  No

If Federal Funds Are Involved, Did The City's Request For Quote / Bid Require Payment of Davis Bacon Wages By The Contractor?  Yes  No Wage Decision No.

**Performance / Payment Bond:**

Did the City's Request For Quote / Bid require a 100% Performance / Payment Bond By The Contractor?  Yes  No

For Contracts Up To \$150,000, Does The Contractor Want To Do A 10% Retainage In Lieu Of A Bond?  Yes  No

Rev. 1/12/2024



**Agenda Sheet for City Council:**

**Committee:** PIES **Date:** 10/21/2024

**Committee Agenda type:** Consent

**Date Rec'd** 10/22/2024

**Clerk's File #** OPR 2024-0926

**Cross Ref #**

**Project #**

**Council Meeting Date:** 11/04/2024

<b>Submitting Dept</b>	SOLID WASTE DISPOSAL	<b>Bid #</b>	ITB 6063-24
------------------------	----------------------	--------------	-------------

<b>Contact Name/Phone</b>	DAVID PAINE 625-6878	<b>Requisition #</b>	VB
---------------------------	----------------------	----------------------	----

<b>Contact E-Mail</b>	DPAINE@SPOKANECITY.ORG		
-----------------------	------------------------	--	--

<b>Agenda Item Type</b>	Purchase w/o Contract		
-------------------------	-----------------------	--	--

<b>Council Sponsor(s)</b>	BWILKERSON JBINGLE KKLITZKE		
---------------------------	-----------------------------	--	--

<b>Agenda Item Name</b>	4490-VALUE BLANKET FOR THE PURCHASE OF HYDROCHLORIC ACID		
-------------------------	--	--	--

**Agenda Wording**

Five year value blanket award to Oxarc (Spokane, WA) for the as-needed purchase of hydrochloric acid (HCL) for use at the Waste to Energy Facility from 1/1/2025-12/31/2029 and a total cost not to exceed \$625,000.00 plus tax.

**Summary (Background)**

Hydrochloric Acid (HCL) is used for the regeneration of the resin in the demineralized water system that provides water to the boilers at the WTE. On September 30, 2024, bidding closed on ITB 6063-24 for the as-needed annual requirement of Hydrochloric Acid (HCL). Four (4) responses were received and Oxarc was the low cost bidder. The value blanket award will be for five (5) years with no renewals. Pricing is firm for the first year of the value blanket.

Lease? NO Grant related? NO Public Works? NO

**Fiscal Impact**

Approved in Current Year Budget? YES

Total Cost	\$ 625,000.00
------------	---------------

Current Year Cost	\$ 125,000.00
-------------------	---------------

Subsequent Year(s) Cost	\$ 125,000.00
-------------------------	---------------

**Narrative**

This is a routine chemical supply expense that was planned for in the Solid Waste Disposal budget.

**Amount**

**Budget Account**

Expense	\$ 625,000.00	# 4490-44100-37148-53203
Select	\$	#
Select	\$	#
Select	\$	#
	\$	#
	\$	#



**Continuation of Wording, Summary, Approvals, and Distribution**

**Agenda Wording**

**Summary (Background)**

**Approvals**

**Dept Head**

AVERYT, CHRIS

**Division Director**

FEIST, MARLENE

**Accounting Manager**

ALBIN-MOORE, ANGELA

**Legal**

SCHOEDEL, ELIZABETH

**For the Mayor**

PICCOLO, MIKE

**Additional Approvals**

**PURCHASING**

PRINCE, THEA

**Distribution List**

mdorgan@spokanecity.org

jsalstrom@spokanecity.org

tprince@spokanecity.org

rrinderle@spokanecity.org

## Committee Agenda Sheet

### Public Infrastructure, Environment & Sustainability Committee

<b>Committee Date</b>	October 21, 2024
<b>Submitting Department</b>	Solid Waste Disposal
<b>Contact Name</b>	David Paine
<b>Contact Email &amp; Phone</b>	<a href="mailto:dpaine@spokanecity.org">dpaine@spokanecity.org</a> , 509-625-6878
<b>Council Sponsor(s)</b>	Wilkerson, Bingle, Klitzke
<b>Select Agenda Item Type</b>	<input checked="" type="checkbox"/> Consent <input type="checkbox"/> Discussion    Time Requested:
<b>Agenda Item Name</b>	Value blanket for the purchase of Hydrochloric Acid (HCL) for use at the Waste to Energy Facility.
<b>Proposed Council Action</b>	<input checked="" type="checkbox"/> Approval to proceed to Legislative Agenda <input type="checkbox"/> Information Only
<b>Summary (Background)</b>	<p>Hydrochloric Acid (HCL) is used for the regeneration of the resin in the demineralized water system that provides water to the boilers at the WTE.</p> <p>*use the Fiscal Impact box below for relevant financial information</p> <p>On September 30, 2024, bidding closed on ITB 6063-24 for the as-needed annual requirement of Hydrochloric Acid (HCL). Four (4) responses were received and Oxarc (Spokane, WA) was the low cost bidder. The value blanket award will be for five (5) years from Jan. 1, 2025 through Dec. 31, 2029 and a total cost not to exceed \$625,000.00 plus tax (approx. \$125,000.00 annually).</p>
<p><b>Fiscal Impact</b></p> <p><b>Approved in current year budget?</b>    <input checked="" type="checkbox"/> Yes    <input type="checkbox"/> No    <input type="checkbox"/> N/A</p> <p>Total Cost: <u>\$625,000.00 plus tax</u></p> <p>    Current year cost: \$125,000.00</p> <p>    Subsequent year(s) cost: \$125,000.00</p> <p><b>Narrative:</b> <u>This is a routine chemical supply expense that was planned for in the Solid Waste Disposal budget.</u></p> <p><b>Funding Source</b>    <input type="checkbox"/> One-time    <input checked="" type="checkbox"/> Recurring    <input type="checkbox"/> N/A</p> <p>Specify funding source: Program revenue</p> <p>Is this funding source sustainable for future years, months, etc? Yes</p> <p><b>Expense Occurrence</b>    <input type="checkbox"/> One-time    <input checked="" type="checkbox"/> Recurring    <input type="checkbox"/> N/A</p> <p>Other budget impacts: (revenue generating, match requirements, etc.)</p>	
<p><b>Operations Impacts (If N/A, please give a brief description as to why)</b></p> <ul style="list-style-type: none"> <li>• What impacts would the proposal have on historically excluded communities? Public works services and projects are designed to serve all citizens and businesses. We strive to offer a consistent level of service to all, to distribute public investment throughout the community and to respond to gaps in services identified in various City plans.</li> <li>• How will data be collected, analyzed, and reported concerning the effect of the program/policy by racial, ethnic, gender identity, national origin, income level, disability, sexual orientation, or other existing disparities? N/A</li> <li>• How will data be collected regarding the effectiveness of this program, policy, or product to ensure it is the right solution?</li> </ul>	



Public Works follows the City's established procurement and public works bidding regulations and policies to bring items forward, and then uses contract management best practices to ensure desired outcomes and regulatory compliance.

- Describe how this proposal aligns with current City Policies, including the Comprehensive Plan, Sustainability Action Plan, Capital Improvement Program, Neighborhood Master Plans, Council Resolutions, and others?

This work is consistent with annual budget strategies to limit costs and approved projects in the 6-year CIP.

**Council Subcommittee Review**

- Please provide a summary of council subcommittee review. If not reviewed by a council subcommittee, please explain why not.

Not applicable

### Bid Response Summary

**Bid Number** ITB 6063-24  
**Bid Title** Hydrochloric Acid, As Needed  
**Due Date** Monday, September 30, 2024 1:00:00 PM [(UTC-08:00) Pacific Time (US & Canada)]  
**Bid Status** Closed to Bidding  
**Company** OXARC  
**Submitted By** JARED FRITZ - Monday, September 30, 2024 9:19:12 AM [(UTC-08:00) Pacific Time (US & Canada)]  
 jfritz@oxarc.com

**Comments**

**Question Responses**

Group	Reference Number	Question	Response
BACKGROUND			
	#1	The City of Spokane, Solid Waste Disposal, Waste To Energy Facility (COS WTE), is located at 2900 S. Geiger Blvd, Spokane WA 99224-5400. COS WTEF operates a 24-hour/365 day per year environment and works under aggressive deadlines and schedules that require vendors to provide high service levels. COS WTEF is initiating this Invitation To Bid to solicit Bids from vendors who have a proven ability to provide spec'd spec's Hydrochloric Acid as needed.	Acknowledged
BID SUBMISSION			
	#1	Bid Responses shall be submitted electronically through the City of Spokane's bidding portal: <a href="https://spokane.procurement.com">https://spokane.procurement.com</a> on or before the Due Date and time mentioned above. Hard, e-mailed or faxed copies and/or late bids shall not be accepted.	Acknowledged
	#2	The City of Spokane is not responsible for bids electronically submitted late. It is the responsibility of the Bidder to be sure the bids are electronically submitted sufficiently ahead of time to be received no later than 1:00 p.m. Pacific Local Time, on the bid opening date.	Acknowledged
	#3	All communication between the Bidder and the City upon receipt of this bid shall be via the "Clarification Tab" within ProcureWare. Any other communication will be considered unofficial and non-binding on the City	Acknowledged
INTERPRETATION			
	#1	If the Bidder discovers any errors, discrepancies, or omissions in the Bid specifications, or has any questions about the specifications, the Bidder must notify Purchasing in writing. Any addenda issued by the Purchaser will be incorporated into the contract or purchase order.	I agree and I acknowledge
WITHDRAWAL OF BIDS			

<p>#1</p>	<p>Bidders may make written request to Purchasing for withdrawal of a sealed Bid prior to the scheduled Bid opening. Unless otherwise specified, no Bids may be withdrawn for a minimum of ninety (90) calendar days after the bid due date.</p>	<p>I agree and I acknowledge</p>
<p>EVALUATIONS OF BIDS</p>		
<p>1</p>	<p>Evaluation of Quotes Shall be based upon the following criteria, where applicable: A. The price, including sales tax and the effect of discounts. Price may be determined by life cycle costing or total cost quoting, when advantageous to the Purchaser. B. The quality of the items quoted, their conformity to specifications and the purpose for which they are required. C. The Bidder's ability to provide prompt and efficient service and/or delivery. D. The character, integrity, reputation, judgment, experience and efficiency of the Bidder. E. The quality of performance of previous contracts or services. F. The previous and existing compliance by the Bidder with the laws relating to the contract or services. G. Uniformity or interchangeability. H. The energy efficiency of the product throughout its life. J. Any other information having a bearing on the decision to award the contract.</p>	<p>Acknowledged</p>
<p>BIDDING ERRORS</p>		
<p>#1</p>	<p>Unit pricing will prevail in the circumstance of unit and extension pricing discrepancies. When, after the opening and tabulation of Bids, a Bidder claims error, and requests to be relieved of award, he will be required to promptly present certified work sheets. The Purchaser will review the work sheets and if the Purchaser is convinced, by clear and convincing evidence, that an honest, mathematically excusable error or critical omission of costs has been made, the Bidder may be relieved of his Bid.</p>	<p>I acknowledge and I understand</p>
<p>REJECTION OF BIDS</p>		
<p>#1</p>	<p>The Purchaser reserves the right to reject any or all Bids; to waive minor deviations from the specifications, to waive any informality in bids received, whenever it is in the Purchaser's best interest, and to accept or reject all or part of this Bid at prices shown.</p>	<p>I agree and I acknowledge</p>
<p>AWARD OF VALUE BLANKET ORDER</p>		
<p>#1</p>	<p>Award of contract or purchase, when made, will be to the Bidder whose Bid is the most favorable to the Purchaser, taking into consideration price and the other evaluation factors. STATE CONTRACTS WHERE APPLICABLE WILL BE CONSIDERED AS A BID. The City Council shall make the award of contract or purchase. Unsuccessful Bidders will not automatically be notified of Bid results.</p>	<p>I agree and I acknowledge</p>
<p>PAYMENT TERMS</p>		

	<p>Payment shall be made via direct deposit/ACH (except as provided by state law) according to net30 terms after receipt of the goods/services ordered. A completed ACH application is required before a City order will be issued. If the City objects to all or any portion of an invoice, it shall notify the supplier and reserve the right to pay only that portion of the invoice not in dispute. In that event, all parties shall immediately make every effort to settle the disputed amount.</p>	<p>I agree and I acknowledge</p>
<p><b>INVOICING</b></p>		
	<p>Invoices must be submitted to Spokane Solid Waste Disposal within 30 days of delivery. • All Invoices shall include Value Blanket Number, Quantity, Current Unit Pricing per Value Blanket, and Tax. • Payment of invoices shall be contingent upon receipt of sufficient detail to permit identification of the delivered items and compliance with contract conditions. Original invoices are required and shall not be approved for payment until all required support is provided. Invoices shall be emailed to <a href="mailto:mdorgan@spokanecity.org">mdorgan@spokanecity.org</a>.</p>	<p>I agree and I acknowledge</p>
<p><b>TERMS AND CONDITIONS</b></p>		
	<p>Bidder acknowledges that they have read and understand the Terms and Conditions Document in the "Documents" tab. If answer is "I don't agree and I don't acknowledge", include requested exception in proposal submittal on separate page and title as "Exception to Terms and Conditions". The City will consider and determine if exception will be accepted.</p>	<p>I agree and I acknowledge</p>
	<p>#1.2 EXCEPTION: If you took exception above, upload here.</p>	
	<p>ELIGIBILITY FOR CITY CONTRACTS: Section 18.09.050 of the Spokane Municipal Code states that the recipient of a City contract, award or purchase order shall certify that it is not knowingly or intentionally a nuclear weapons producer. The Bidder certifies that his/her firm is not a nuclear weapons producer.</p>	<p>I certify</p>
<p><b>BIDDER INFORMATION</b></p>		
	<p>Please indicate the appropriate point of contact (including phone number and email) regarding this Bid and placement of orders if awarded. If these actions will not be managed by the same person, please explicitly specify all relevant contacts.</p>	<p>Jared Fritz  <a href="mailto:jfritz@oxarc.com">jfritz@oxarc.com</a>            360-901-8584</p>
<p><b>ORGANIZATION</b></p>		
	<p>Organization: Bidder Should Enter If Proposal Is of an Individual, Partnership, Corporation, and Existing Under The Laws of What US State. Enter Information Here</p>	<p>Washington</p>
<p><b>BUSINESS REGISTRATION:</b></p>		
<p></p>		

1	<p>Section 8.01.070 of the Spokane Municipal Code states that no person may engage in business with the City without first having obtained and being the holder of a valid annual business registration or temporary business registration as provided in this chapter. The supplier shall be responsible for contacting the State of Washington Business License Services at <a href="http://bls.dor.wa.gov">http://bls.dor.wa.gov</a> or 1-360-705-6741 to obtain a business registration. If the supplier does not believe it is required to obtain a business registration, it may contact the City's Taxes and Licenses Division at 509-625-6070 to request an exemption status determination.</p>	I agree and I acknowledge
2	City of Spokane Business Registration Number:	A00192025
<p>PROPRIETARY INFORMATION/PUBLIC DISCLOSURE</p>		
1	<p>Materials submitted in response to this competitive procurement shall become the property of the City. All received Proposals shall remain confidential until the award of contract recommendation has been filed with the applicable Council Committee or the City Clerk for City Council action. Thereafter, the Proposals shall be deemed public records as defined in RCW 42.56, "Public Records." Any information in the Proposal that the Proposer desires to claim as proprietary and thus exempt from disclosure under the provisions of existing state law, shall be clearly designated. Each page claimed to be exempt from disclosure must be clearly identified by the word "Confidential" printed on it. Marking the entire Proposal exempt from disclosure will not be honored. The City will consider a Proposer's request for exemption from disclosure; however, the City will make a decision predicated upon state law and regulations. If any information is marked as proprietary in the Proposal, it will not be made available until the affected Proposer has been given an opportunity to seek a court injunction against the requested disclosure.</p>	I agree and I acknowledge
<p>BIDDER PREQUALIFICATION</p>		
#1	<p>Prior to award of contract or purchase, Bidders shall be required to submit evidence of sufficient facilities, equipment, experience and financial ability to insure completion of the work, unless waived by the COS WTEF.</p>	I agree and I acknowledge
<p>INSURANCE</p>		
1	<p>Awarded Vendor must provide Certificate of Insurance, at its own expense, prior to performing deliver for the below insurance coverage(s):</p>	I agree and I acknowledge
Empty row for insurance details		

2	a. Worker's Compensation Insurance in compliance with RCW 51.12.020 which requires subject employers to provide worker's compensation coverage for all their subject workers and Employer's Liability Insurance in the amount of \$1,000,000.00.	I agree and I acknowledge
3	b. General Liability Insurance on an occurrence basis, with a combined single limit of not less than \$1,000,000.00 for bodily injury and property damage. It shall include premises and operations, independent contractors, products and completed operations, personal injury liability, and contractual liability coverage for the indemnity provided under the contract. It shall provide that the City, its officers, and employees are additional insureds but only with respect to the Contractor's services to be provided under the contract; i. Acceptable supplementary Umbrella insurance coverage, combined with the Contractor's General Liability Insurance policy must be a minimum of \$1,500,000.00 in order to meet the insurance coverages required under this Contract.	I agree and I acknowledge
4	c. Property Insurance if materials and supplies are furnished by the Contractor. The amount of the insurance coverage shall be the value of the materials and supplies or the completed value of the improvement. Hazard or XCU (Explosion, Collapse, Underground) Insurance should be provided if any hazard exists; and	I agree and I acknowledge
5	d. Automobile Liability Insurance with a combined single limit, or the equivalent of not less than \$1,000,000.0 each accident for bodily injury and property damage, including coverage for owned, hired and non-owned vehicles.	I agree and I acknowledge
6	There shall be no cancellation, material change, reduction of limits or intent not to renew the insurance coverage(s) without thirty (30) days written notice from the Company or its insurer(s) to the City. As evidence of the insurance coverage(s) required by this Agreement, the Company shall furnish acceptable Certificates of Insurance (COI) upon request by the City. The certificate shall specify the City of Spokane as "Additional Insured" specifically for Company's services under this Agreement, as well as all of the parties who are additional insureds, and include applicable policy endorsements, the thirty (30) day cancellation clause, and the deduction or retention level. The Company shall be financially responsible for all pertinent deductibles, self-insured retentions, and/or self-insurance	I agree and I acknowledge

ADDITIONAL ITEMS

	#1	The City of Spokane reserves the right to purchase additional quantities of these items at the quoted price. Vendor agrees to sell at the same price, terms, and conditions. If Yes, prices are good until further written notice.	Yes
INTERLOCAL PURCHASE AGREEMENTS			
	#1	INTERLOCAL PURCHASE AGREEMENTS #1 The City of Spokane has entered into Interlocal Purchase Agreements with other public agencies pursuant to chapter 39.34 RCW. In submitting a response, the Bidder agrees to provide its services to other public agencies at the same contracted price, terms and conditions it is providing to the City of Spokane, contingent upon the supplier's review and approval at the time of a requested contract. The Vendor's right to refuse to enter into a contract with another public agency at the time of request shall be absolute.	Yes
MINORITY BUSINESS ENTERPRISE			
	#1	Vendor ( IS ) ( IS NOT ) a Minority Business Enterprise. A Minority Business Enterprise is defined as a "business, privately or publicly owned, at least 51% of which is owned by minority group members." For purpose of this definition, minority group members are Blacks, Hispanics, Asian Americans, American Indian or Alaskan Natives, or Women.	Is
SMALL BUSINESS			
	#1	Vendor ( IS ) ( IS NOT ) a small business concern. (A small business concern for the purpose of government procurement is a concern, including its affiliates, which is independently owned and operated, is not dominant in the field of operations in which it is bidding on government contracts, and can further qualify under the criteria concerning number of employees, average annual receipts, or other criteria as prescribed by the Small Business Administration).	Is
NON-COLLUSION			
	#1	The Bidder certifies that his/her firm has not entered into any agreement of any nature whatsoever to fix, maintain, increase, or reduce the prices or competition regarding the items covered by this Bid invitation.	Certifies No Agreement Has Been Entered
ACCEPTANCE PERIOD			
	#1	Bids must provide a minimum of ninety (90) calendar days for acceptance by the City from the due date.	I agree and I acknowledge
TERM OF VALUE BLANKET ORDER			

1	Upon City Council approval, the Value Blanket Order resulting from this ITB will be for a five year period, beginning January 1, 2025, and terminate on December 31, 2029. The Vendor's prices shall be firm throughout the first year.	I agree and I acknowledge
<b>GENERAL INSTRUCTIONS</b>		
#1	The Items to be furnished by the Bidder must be of the latest possible production.	I agree and I acknowledge
#2	Time is of the essence in the performance of this contract.	I agree and I acknowledge
#3	Successful bidder will designate a representative who will be available during regular City business hours to serve as a primary contact for the City in the implementation of this supply agreement and if any issues arise regarding the product.	I agree and I acknowledge
#4	The City of Spokane reserves the right to accept or reject any variance from the published specifications and to award the Bid in a manner that is most advantageous to the continued efficient operation of the City.	I agree and I acknowledge
#5	The City reserves the right to accept or reject any part of or all Bids, and to accept the Bid deemed to be in the best interest of the City.	I agree and I acknowledge
#6	The City of Spokane reserves the option of awarding this purchase by item grouping or by any manner most advantageous for the City.	I agree and I acknowledge
#7	Bidder should be aware that Bids may be rejected if all questions are not completely and correctly answered.	I agree and I acknowledge
<b>SPECIAL INSTRUCTIONS</b>		
#1	If the product differs from the provisions contained herein, these differences must be explained in detail.	I agree and I acknowledge
#2	Vendors found to have "overstated" the true ability of their product shall reimburse the City for all costs incurred with remanufacturing or replacement of units until all criteria has been satisfied. These costs shall also include legal, rentals, travel, etc.	I agree and I acknowledge
#3	The omission of any standard feature described herein shall not void the bidder's responsibility to furnish product of manufacturer's latest production. Product must be new and unused.	I agree and I acknowledge
#4	Successful bidder shall furnish standard warranty.	I agree and I acknowledge
#4.1	State warranty:	If defective or inaccurate warranty is in discussion.
#5	Federal and State laws governing this product and its final certification must be satisfied.	I agree and I acknowledge
#6	It shall be the Vendor's responsibility to conform to all Federal Standards for certification.	I agree and I acknowledge



#7	Delivery time shall be a consideration of awarding this contract. Therefore the City requests a completed delivery date as soon as possible after receipt any order placed against the resulting Value Blanket Contract award.	I agree and I acknowledge
#8	Any technical specifications and general provisions listed are the minimum acceptable requirements and failure to comply may be used as a basis for rejection of the Bid.	I agree and I acknowledge
POLYCHLORINATED BIPHENYLS (PCBs):		
1	In accordance with SMC 7.06.172(A), the Bidder certifies that the products bid and to be supplied (to include product packaging) do not contain polychlorinated biphenyls (PCB's). Moreover and consistent with SMC 7.06.172(B), the City of Spokane, at its sole discretion, may require (at no cost to the City) the apparent successful bidder to provide testing data (prior to contract execution or issue of purchase order) from an accredited laboratory or testing facility documenting the proposed products and or product packaging polychlorinated biphenyl levels.	Yes
1.1	As far as you know has this type product been tested for PCBs by a WA State accredited lab using EPA Method 1668c (or equivalent as updated)?	Yes
1.2	If so were PCBs found at a measurable level?	Yes
1.3	As far as you know has this actual product been tested for PCBs by a WA State accredited lab using EPA Method 1668 (or equivalent as updated)?	Yes
1.4	If so attach the results or note from whom the results can be obtained.	cascade columbia distribution
1.5	Do you have reason to believe the product contains measurable levels of PCBs?	No
1.6	Do you have reason to believe the product packaging contains measurable levels of PCBs?	No
TECHNICAL SPECIFICATIONS		
#1	Any references herein to a particular make or model number are intended not to be restrictive, but to set forth an acceptable level of quality and design.	I agree and I acknowledge
#2	Any Hydrochloric Acid delivered that does not meet specifications will not be acceptable. If the bidder's product is unsatisfactory but was inadvertently placed into the facilities system prior to rejection and subsequently causes physical damage or extra cleanup labor, the City will be reimbursed for any associated costs, and at the City's option, a new supplier will be used. Any equipment damage, down time, labor charges, fines, or any other costs caused by material that does not meet specifications or was not delivered on time, will be assumed by the vendor.	I agree and I acknowledge

#3	All Chemicals delivered shall be meet the following technical specifications that are the minimum acceptable specifications and failure to comply may be used as a basis for rejection of the Bid.	I agree and I acknowledge
#3.1	HYDROCHLORIC ACID 20 DEGREE BAUMCOMMERCIAL GRADE (9.6 pounds per gallon).	I agree and I acknowledge
#3.2	Hydrochloric Acid Weight: 30.5% - 32.0%.	I agree and I acknowledge
#3.3	Sulfate (SO4) Weight %: 0.5% Maximum by Weight.	I agree and I acknowledge
#3.4	Iron (as Fe): 5 ppm Maximum.	I agree and I acknowledge
#3.5	Total Oxidizing Substance as CL2: 30 ppm Maximum.	I agree and I acknowledge
#3.6	Total Organic Carbon: 20 ppm Maximum.	I agree and I acknowledge
#3.7	Color: (APHA): 25 Maximum.	I agree and I acknowledge
#3.8	Specific Gravity: 1.152 - 1.1628.	I agree and I acknowledge
#4	Bidder must uploaded Safety Date Sheet. Upload SDS	MURIATIC ACID 30-35__ CCDC 2-12-19 SDS.pdf
#5	State name(s) and address(es) of Original Equipment Manufacturer (OEM) and distributors (if applicable) to be used in the production and delivery of your product.	Cascade Columbia 6900 Fox Ave S, Seattle, WA 98108
#5.1	Vendor cannot change chemical sources without written approval by the City of Spokane.	I agree and I acknowledge
#6	Bidders must submit cover letters stating qualifications for supplying specified product on contract with the City of Spokane. Upload cover letter document.	city of spokane cover letter.doc
#7	References are to be included with Bid. Bidder shall furnish names, addresses, telephone numbers, and email addresses of representatives of at least three companies/municipalities which have been continually using the product being bid for at least two years. If no references are completely applicable, provide two references which most nearly apply. References must be located in similar climates.	Charles Noble 208-217-8135 cnoble@oxarc.com Rich ford 509-535-7794 rford@oxarc.com
#8	Awarded Vendor to provide Pump out Services of COS WTEF storage tank should need arise, providing associated labor and tankers required. This requirement may occur once every three or five years.	I agree and I acknowledge
#8.1	Should Pump-Out Services be required, Vendor would need an approximate advance notice of how many calendar days?	15 days
#9	EXCEPTIONS If you marked "I do not acknowledge and agree" on any of the areas above, explain here what you are taking exception to.	
DELIVERY		

#1	DELIVERY - F.O.B. POINT: Transferred into to storage tank at City of Spokane Waste To Energy Facility, South 2900 Geiger Blvd., Spokane WA 99224.	I agree and I acknowledge
#2	Capacity of Vendor's tankers shall comply with DOT specifications.	I agree and I acknowledge
#3	Delivery method is to be compatible with unloading equipment at delivery point – Waste to Energy Facility.	I agree and I acknowledge
#4	Vendors must provide 48 hour prior notification of delivery by contacting the Control Room at 509 625-6516.	I agree and I acknowledge
#5	Vendor shall check in at WTEF Control Room upon arriving at WTEF prior to offloading. All WTEF Safety procedures shall be adhered to while on WTEF premises. Contractor will be held responsible to comply with the established receiving program.	I agree and I acknowledge
#6	Deliveries shall be made between 7:30 a.m. and 2:30 p.m. Monday through Friday, with the exception of recognized holidays unless arranged in advance. The City is not liable for any charges due to traffic at the WTEF. Deliveries may be necessary on Holidays depending on last previous delivery.	I agree and I acknowledge
#7	Vendor shall provide Bill of Lading for each delivery reflecting quantity of pounds delivered and offloaded ensuring Bill of Lading is signed by WTEF City Employee.	I agree and I acknowledge
#7.1	Specification Sheet, Certificate of Analysis, Bill of Lading, Safety Date Sheet to accompany each delivery.	I agree and I acknowledge
#8	Quantities shown are estimates only and are not guaranteed. Actual usage may be more or less. Orders will be placed as needed throughout contract term. Payment would only be made for actual orders placed, delivered, and accepted.	I agree and I acknowledge
#8.1	Delivery frequency is approximately every 15 to 19 calendar days, more or less, with an average delivery weight of ranging from 7,680 lbs. to 9,600 lbs. more or less, equating to Annual Average Quantity ranging from 153,840 lbs. to 228,988 lbs. more or less.	I agree and I acknowledge
#8.1.1	Order History For Reference Only:	No
#8.1.1.1	1/1/2020 to 1/31/2020: Nineteen (19) Deliveries, Average pounds per delivery 7,731 bs, Total Pounds Delivered 146,880 lbs.	Acknowledged
#8.1.1.2	1/1/2021 to 12/31/2021: Twenty (20) Deliveries, Average pounds per delivery 8580 lbs, Total Pounds Delivered 171600 lbs.	Acknowledged
#8.1.1.3	1/1/2022 to 12/31/2022: Eighteen (18) Deliveries, Average pounds per delivery 8,547 lbs., Total Pounds Delivered 153,840 lbs.	Acknowledged
#8.1.1.4	1/1/2023 to 12/31/2023: Twenty Six (26) Deliveries, Average pounds per delivery 8,807 lbs., Total Pounds Delivered 228,988 lbs.	Acknowledged

#8.1.1.5	1/1/2024 to 7/30/2024. Sixteen (16) Deliveries thus far, Average pounds per delivery 8,310 lbs., Total Pounds Delivered thus far 132,999 lbs.	Acknowledged
#9	What is the minimum advance notice in calendar-days Supply would need to provide delivery. Enter number of calendars.	5 days
#9.1	Emergency deliveries to be made within 24 hours of request. COS WTEF will endeavor to keep emergency deliveries to a minimum. Could Vendor meet this requirement?	yes
#10	Contractor shall be available 24 hours on call.	I agree and I acknowledge
#11	EXCEPTIONS If you marked "I do not acknowledge and agree" on any of the areas above, explain here what you are taking exception to.	
<b>PRICING</b>		
#1	Sales Tax: The City of Spokane is not a tax exempt entity and is therefore obligated to pay sales tax under Washington State law. Sales tax should --not-- be included in bidder's unit pricing. All submissions shall be tabulated by the City who with the applicable sales tax rate whether that tax shall be charged through the supplier or paid by the City as use tax.	I agree and I acknowledge
#2	FREIGHT TRANSPORTATION CHARGES will be the responsibility of the winning Vendor.	I agree and I acknowledge
#3	Unit Pricing Shall be Delivered-Price-Per-Wet-Pound.	I agree and I acknowledge
#3.1	Delivered-Unit-Price-Per-Wet-Pound shall be all-inclusive of cost that could be incurred to include but not limited to: Hydrochloric Acid, Freight, Transport, Delivery, Handling, Demurrage Charges, Insurance and Security (if applicable), and Fuel Surcharge (if applicable).	I agree and I acknowledge
#3.2	Bidder acknowledges that the delivered-price-per-wet-pound indicated on the Pricing Page includes ALL expenses that could be incurred. No other costs will be allowed over and above the bid price.	I agree and I acknowledge
#3.3	Unit Pricing should Not Include Tax.	I agree and I acknowledge
#4	Bidder has entered Pricing on the Pricing Form.	I agree and I acknowledge
#4.1	The Vendor's prices shall be firm throughout the first year of the contract period.	I agree and I acknowledge
#4.2	PRICING ADJUSTMENTS:	Yes

#4.2.1	Adjustments to pricing shall be the result of increases at the manufacturer's level, incurred after contract commencement date, shall not produce a higher profit margin than that on the original contract, clearly identify the items impacted by the increase, and be accompanied by documentation acceptable to Spokane City sufficient to justify the requested increase. Spokane City will be the sole judge as to the acceptability of sources. Acceptance of a request will be at the sole discretion of Spokane City. Price increases will not be considered before the end of the first term (implied first 12-months) of the Contract. Approved price adjustments shall remain unchanged for at least 12 months thereafter unless due to extraordinary circumstances as documented by the Contractor and concurred with by the City. A written request for a price adjustment will be submitted a minimum of sixty (60) calendar days in advance of a proposed affective date. An approved price increase will become effective after the approval of the increase. Retroactive price increase adjustments will not be considered.	I agree and I acknowledge
#4.2.2	Back up documentation from manufacturer and/or other sources must be included to justify request. The United States published indices such as the Producer Price Index (PPI), or other government data, may be referenced to help substantiate the Vendor's documentation.	I agree and I acknowledge
#4.2.3	All price adjustments must be agreed on by both parties. Vendor must request pricing adjustment in writing, and cannot be applied retroactively to orders already placed with the Vendor. Price increases must apply to all or broad classes of customers and shall in no way single out the Purchaser.	I agree and I acknowledge
#4.2.4	Approved price changes will be put into effect through the use of a change order to the Agreement. Price changes will not be retroactive.	I agree and I acknowledge
#4.2.5	The City of Spokane reserves the right to cancel the contract if the escalation of price is not advantageous to the City. Failure to reach agreement on a request for an increase in price(s) can, at the sole option of the City, result in the termination of the Agreement for cause.	I agree and I acknowledge
#5	PRICE DECREASES: During the contract period, any price decreases obtained by Contractor shall be reflected in a contract price reduction to the Purchaser retroactive to the Vendor's effective date.	I agree and I acknowledge
#6	Cost for Pump-Out Services would be addressed when service is required.	I agree and I acknowledge
ADDITIONAL DOCUMENTS BIDDER WOULD LIKE TO UPLOAD		

#1	If you have additional information/documents to submit, upload them here.
#2	If you have additional information/documents to submit, upload them here.
#3	If you have additional information/documents to submit, upload them here.
#4	If you have additional information/documents to submit, upload them here.

**Pricing Responses**

Group	Reference Number	Description	Type	Unit Of Measure	Quantity	Unit Price	Ext Base Price	Comment
Annual Quantities shown on "Pricing Tab" are estimates only and are not to be construed as firm or guaranteed. Quantities are estimates only and are given for the purpose of comparing bids on a uniform basis. Unit Pricing SHOULD NOT include tax.								

PRODUCT	Spec'd	Base	Delivered- Price-Per- Wet- Pound	228,988.00	\$0.35	\$80,145.80
	<p>Hydrochloric Acid. Unit Pricing shall be Delivered-Price-Per-Wet-Pound. Delivered-Unit-Price-Per-Pound shall be all-inclusive of cost that could be incurred. Delivered-Unit-Price-Per-Pound should NOT include tax. Delivered-Unit-Price-Per-Pound shall be firm throughout the first year of the contract period. A written request for a price adjustment will be submitted a minimum of sixty (60) calendar days in advance of a proposed affective date. An approved price increase will become effective after the approval of the increase. Retroactive price increase adjustments will not be considered.</p>					

Approved price adjustments shall remain unchanged for at least 12 months thereafter unless due to extraordinary circumstances as documented by the Contractor and concurred with by the City. Annual estimated quantity is 228,988 pounds delivered.

EMERGENCY DELIVERY



<p>PRODUCT - EMERGENCY DELIVERY</p>	<p>All inclusive Delivered- Price-Per- Wet-Pound, for Emergency Delivery. Emergency Delivered- Unit-Price- Per-Pound should NOT include tax. Delivered- Unit-Price- Per-Pound shall be firm throughout the first year of the contract period. A written request for a price adjustment will be submitted a minimum of sixty (60) calendar days in advance of a proposed affective date. An approved price increase will become effective after the approval of the increase. Retroactive price increase adjustments will not be considered. Approved price adjustments shall remain unchanged for at least 12 months</p>	<p>Base</p>	<p>Delivered- Price-Per- Wet- Pound</p>	<p>1.00</p>	<p>\$75.00</p>	<p>\$75.00</p>
---	--	-------------	---	-------------	----------------	----------------

thereafter  
unless due to  
extraordinary  
circumstances  
as  
documented  
by the  
Contractor  
and  
concurred  
with by the  
City.

<b>Total Base Bid</b>	\$80,220.80
-----------------------	-------------



# OXARC, Inc. Memorandum

**Date:9-30-2024**

**TO: City of Spokane**

**From: Oxarc LLC**

**Subject: Hydrochloric Acid Bid**

**To who it may concern:**

**Oxarc LLC is capable of delivery and fulfilling the requirements of this bid for the Hydrochloric Acid. If there is any questions about deliveries please contact Jared Fritz at 360-901-8584 or [Jfritz@oxarc.com](mailto:Jfritz@oxarc.com).**



## SAFETY DATA SHEET

This Safety Data Sheet conforms to ANSI Z400.5, and to the format requirements of the Global Harmonizing System.

THIS SDS COMPLIES WITH 29 CFR 1910.1200 (HAZARD COMMUNICATION STANDARD)

IMPORTANT: Read this SDS before handling & disposing of this product.  
Pass this information on to employees, customers, & users of this product.

### SECTION 1. IDENTIFICATION OF THE SUBSTANCE OR MIXTURE AND OF THE SUPPLIER

PRODUCT IDENTITY: MURIATIC ACID (TECHNICAL GRADE) 30-35%  
SYNONYMS: Hydrochloric Acid, Hydronium chloride  
PRODUCT USES: Mineral Acid  
COMPANY IDENTITY: Cascade Columbia Distribution Company  
COMPANY ADDRESS: 6900 Fox Avenue S.  
COMPANY CITY: Seattle, WA 98108  
COMPANY PHONE: 1-206-763-2351  
EMERGENCY PHONES: CHEMTREC: 1-800-424-9300 (USA)  
CANUTEC: 1-613-996-6666 (CANADA)

### SECTION 2. HAZARDS IDENTIFICATION

**DANGER!!**



#### 2.1 HAZARD STATEMENTS: (CAT = Hazard Category)

- (H200s) PHYSICAL: Corrosive To Metals(CAT:1)  
**H290 MAY BE CORROSIVE TO METALS.**
- (H300s) HEALTH: Acute Toxicity, Oral(CAT:1)  
**H300 FATAL IF SWALLOWED.**
- (H300s) HEALTH: Skin Corrosion/Irritation(CAT:1)  
**H314 CAUSES SEVERE SKIN BURNS AND EYE DAMAGE.**
- (H300s) HEALTH: Acute Toxicity, Inhalation(CAT:3)  
**H331 TOXIC IF INHALED.(CAT:3)**
- (H300s) HEALTH: Specific Target Organ Toxicity, Single Exposure(CAT:3)  
**H335 MAY CAUSE RESPIRATORY IRRITATION.**

#### 2.2 PRECAUTIONARY STATEMENTS:

##### EXPOSURE PREVENTION:

**CAUSES SEVERE BURNS TO EYES, SKIN, AND DIGESTIVE TRACT.**

**DO NOT BREATHE FUME/GAS/MIST/VAPORS/SPRAY.**

**P100s = General, P200s = Prevention, P300s = Response, P400s = Storage, P500s = Disposal**

- P234 Keep only in original container.
- P260 Do not breathe dust/fume/gas/mist/vapors/spray.
- P264 Wash with soap & water thoroughly after handling.
- P270 Do not eat, drink or smoke when using this product.
- P271 Use only outdoors or in a well-ventilated area.
- P280 Wear protective gloves/protective clothing/eye protection/face protection.
- P301+330+331 IF SWALLOWED: Rinse mouth. Do NOT induce vomiting.
- P303+361+353 IF ON SKIN (OR HAIR): Remove/Take off immediately all contaminated clothing. Rinse skin with water/shower.
- P304+340 IF INHALED: Remove victim to fresh air & keep at rest in a position comfortable for breathing.
- P305+351+338 IF IN EYES: Rinse cautiously with water for several minutes. Remove contact lenses if present & easy to do - Continue rinsing.
- P310 Immediately call a POISON CENTER or doctor/physician.
- P312 Call a POISON CENTER or doctor/physician if you feel unwell.
- P363 Wash contaminated clothing before reuse.
- P390 Absorb spillage to prevent material damage.
- P403+233 Store in a well-ventilated place. Keep container tightly closed.
- P405 Store locked up.
- P406 Store in corrosive resistant container with a resistant inner liner.
- P500 Dispose of contents/container following local/regional/federal regulations.

**SEE SECTIONS 8, 11 & 12 FOR TOXICOLOGICAL INFORMATION.**

### SECTION 3. COMPOSITION/INFORMATION ON INGREDIENTS

MATERIAL	CAS#	EINECS#	WT %
Water	7732-18-5	-	65-70
Hydrochloric Acid	7647-01-0	231-595-7	30-35

TRACE COMPONENTS: Trace ingredients (if any) are present in < 1% concentration, (< 0.1% for potential carcinogens, reproductive toxins, respiratory tract mutagens, and sensitizers). None of the trace ingredients contribute significant additional hazards at the concentrations that may be present in this product. All pertinent hazard information has been provided in this document, per the requirements of the Federal Occupational Safety and Health Administration Standard (29 CFR 1910.1200), U.S. State equivalents, and Canadian Hazardous Materials Identification System Standard (CPR 4).

### SECTION 4. FIRST AID MEASURES

#### 4.1 MOST IMPORTANT SYMPTOMS/EFFECTS, ACUTE & DELAYED:

See Section 11 for symptoms/effects, acute & delayed.

#### 4.2 GENERAL ADVICE:

First Aid responders should pay attention to self-protection and use the recommended protective clothing (chemical resistant gloves, splash protection). If potential for exposure exists, refer to Section 8 for specific personal protective equipment.

#### 4.3 EYE CONTACT:

If this product enters the eyes, open eyes while under gently running water. Use sufficient force to open eyelids. "Roll" eyes to expose more surface. Minimum flushing is for 15 minutes. Seek immediate medical attention.

#### 4.4 SKIN CONTACT:

If the product contaminates the skin, immediately begin decontamination with running water. Minimum flushing is for 15 minutes. Remove contaminated clothing, taking care not to contaminate eyes. If skin becomes irritated and irritation persists, medical attention may be necessary. Wash contaminated clothing before reuse, discard contaminated shoes.

#### 4.5 INHALATION:

After high vapor exposure, remove to fresh air. If breathing is difficult, give oxygen. If breathing has stopped, trained personnel should immediately begin artificial respiration. If the heart has stopped, trained personnel should immediately begin cardiopulmonary resuscitation (CPR). Seek immediate medical attention.

#### 4.6 SWALLOWING:

If swallowed, CALL PHYSICIAN OR POISON CONTROL CENTER FOR MOST CURRENT INFORMATION. If professional advice is not available, give two glasses of water to drink. DO NOT INDUCE VOMITING. Never induce vomiting or give liquids to someone who is unconscious, having convulsions, or unable to swallow. Seek immediate medical attention.

#### 4.7 RESCUERS:

Rescuers should be taken for medical attention, if necessary. Take a copy of label and SDS to physician or health professional with victim.

#### 4.8 NOTES TO PHYSICIAN:

There is no specific antidote. Treatment of overexposure should be directed at the control of symptoms and the clinical condition of the patient. Any material aspirated during vomiting may cause lung injury. Therefore, emesis should not be induced mechanically or pharmacologically. If it is considered necessary to evacuate the stomach contents, this should be done by means least likely to cause aspiration (such as: Gastric lavage after endotracheal intubation). Victims of chemical exposure must be taken for medical attention.

### SECTION 5. FIRE FIGHTING MEASURES

#### 5.1 FIRE & EXPLOSION PREVENTIVE MEASURES:

Isolate from alkalis. Refer to Section 10 for incompatibilities.

#### 5.2 SUITABLE (& UNSUITABLE) EXTINGUISHING MEDIA:

Material does not burn. In case of fire in surroundings, use appropriate extinguishing media.

#### 5.3 SPECIAL PROTECTIVE EQUIPMENT & PRECAUTIONS FOR FIRE FIGHTERS:

Water spray may be ineffective on fire but can protect fire-fighters & cool closed containers. Use fog nozzles if water is used. Do not enter confined fire-space without full bunker gear. (Helmet with face shield, bunker coats, gloves & rubber boots).

5.4 SPECIFIC HAZARDS OF CHEMICAL & HAZARDOUS COMBUSTION PRODUCTS:

Reacts with most metals producing hydrogen which is extremely flammable & may explode. Applying to hot surfaces requires special precautions. Closed containers may explode if exposed to extreme heat.

**SECTION 6. ACCIDENTAL RELEASE MEASURES**

6.1 SPILL AND LEAK RESPONSE AND ENVIRONMENTAL PRECAUTIONS:

Uncontrolled releases should be responded to by trained personnel using pre-planned procedures. Proper protective equipment should be used. In case of a spill, clear the affected area, protect people, and respond with trained personnel. ELIMINATE all ignition sources (no smoking, flares, sparks, or flames in immediate area).

6.2 PERSONAL PRECAUTIONS, PROTECTIVE EQUIPMENT, EMERGENCY PROCEDURES:

The proper personal protective equipment for incidental releases (such as: 1 Liter of the product released in a well-ventilated area), use impermeable gloves, they should be Level B: triple-gloves (rubber gloves and nitrile gloves over latex gloves), chemical resistant suit and boots, hard-hat, and Self-Contained Breathing Apparatus specific for the material handled, goggles, face shield, and appropriate body protection. In the event of a large release, use impermeable gloves, specific for the material handled, chemically resistant suit and boots, and hard hat. Self-Contained Breathing Apparatus or respirator may be required where engineering controls are not adequate or conditions for potential exposure exist. When respirators are required, select NIOSH/MSHA approved based on actual or potential airborne concentrations in accordance with latest OSHA and/or ANSI recommendations.

6.3 ENVIRONMENTAL PRECAUTIONS:

Stop spill at source. Construct temporary dikes of dirt, sand, or any appropriate readily available material to prevent spreading of the material. Close or cap valves and/or block or plug hole in leaking container and transfer to another container. Keep from entering storm sewers and ditches which lead to waterways, and if necessary, call the local fire or police department for immediate emergency assistance.

6.4 METHODS AND MATERIAL FOR CONTAINMENT & CLEAN-UP:

Absorb spilled liquid with polypads or other suitable absorbent materials. If necessary, neutralize using suitable buffering material, (acid with soda ash or base with phosphoric acid), and test area with litmus paper to confirm neutralization. Clean up with non-combustible absorbent (such as: sand, soil, and so on). Shovel up and place all spill residue in suitable containers. dispose of at an appropriate waste disposal facility according to current applicable laws and regulations and product characteristics at time of disposal (see Section 13 - Disposal Considerations).

**SECTION 7. HANDLING AND STORAGE**

7.1 PRECAUTIONS FOR SAFE HANDLING:

Use only with adequate ventilation. Avoid breathing of vapor or spray mist. Do not get in eyes, on skin or clothing. Wear OSHA Standard full face shield. Consult Safety Equipment Supplier. Wear goggles, face shield, gloves, apron & footwear impervious to material. Wash clothing before reuse. NEVER pour water into this substance. When dissolving or diluting, always add it slowly to the water.

7.2 CONDITIONS FOR SAFE STORAGE, INCLUDING ANY INCOMPATIBILITIES:

Keep separated from strong oxidants, strong bases, combustible & reducing substances, metals. Keep cool. Keep dry. Keep inside a well-ventilated room. Do not store above 49 C/120 F. Keep container tightly closed & upright when not in use to prevent leakage. Reacts with most metals producing hydrogen which is extremely flammable & may explode. Wear full face shield, gloves & full protective clothing when opening or handling. When empty, drain completely, replace bungs securely.

7.3 NONBULK: CONTAINERS:

Store containers in a cool, dry location, away from direct sunlight, sources of intense heat, or where freezing is possible. Material should be stored in secondary containers or in a diked area, as appropriate. Store containers away from incompatible chemicals (see Section 10, Stability and Reactivity). Post warning and "NO SMOKING" signs in storage and use areas, as appropriate. Empty containers should be handled with care. Never store food, feed, or drinking water in containers which held this product.

7.4 BULK CONTAINERS:

All tanks and pipelines which contain this material must be labeled. Perform routine maintenance on tanks or pipelines which contain this product. Report all leaks immediately to the proper personnel.

**7.5 TANK CAR SHIPMENTS:**

Tank cars carrying this product should be loaded and unloaded in strict accordance with tank-car manufacturer's recommendation and all established on-site safety procedures. Appropriate personal protective equipment must be used (see Section 8, Engineering Controls and Personal Protective Equipment.). All loading and unloading equipment must be inspected, prior to each use. Loading and unloading operations must be attended, at all times. Tank cars must be level, brakes must be set or wheels must be locked or blocked prior to loading or unloading. Tank car (for loading) or storage tanks (for unloading) must be verified to be correct for receiving this product and be properly prepared, prior to starting the transfer operations. Hoses must be verified to be in the correct positions, before starting transfer operations. A sample (if required) must be taken and verified (if required) prior to starting transfer operations. All lines must be blown-down and purged before disconnecting them from the tank car or vessel.

**7.6 PROTECTIVE PRACTICES DURING MAINTENANCE OF CONTAMINATED EQUIPMENT:**

Follow practices indicated in Section 6 (Accidental Release Measures). Make certain application equipment is locked and tagged-out safely. Always use this product in areas where adequate ventilation is provided. Collect all rinsates and dispose of according to applicable Federal, State, Provincial, or local procedures.

**7.7 EMPTY CONTAINER WARNING:**

Empty containers may contain residue and can be dangerous. Do not attempt to refill or clean containers without proper instructions. Empty drums should be completely drained and safely stored until appropriately reconditioned or disposed. Empty containers should be taken for recycling, recovery, or disposal through suitably qualified or licensed contractor and in accordance with governmental regulations. **DO NOT PRESSURIZE, CUT, WELD, BRAZE, SOLDER, DRILL, GRIND, OR EXPOSE SUCH CONTAINERS TO HEAT, FLAME, SPARKS, STATIC ELECTRICITY, OR OTHER SOURCES OF IGNITION. THEY MAY BURST AND CAUSE INJURY OR DEATH.**

**SECTION 8. EXPOSURE CONTROLS/PERSONAL PROTECTION**

**8.1 EXPOSURE LIMITS:**

CHEMICAL	OSHA			ACGIH		HAP	NIOSH	
	TWA	STEL	CEILING	TLV	CEILING		IDLH	REL
Hydrochloric Acid	5ppm	5ppm	None Known	2ppm	7mg/m3	Yes	50ppm	5mpm

Each component showing `Yes' under "HAP" is an EPA Hazardous Air Pollutant.

**8.2 APPROPRIATE ENGINEERING CONTROLS:**

**RESPIRATORY EXPOSURE CONTROLS**

Use of engineering controls to eliminate worker exposure to fumes or mists is strongly recommended. If exposure limit is exceeded, a full-facepiece respirator with high efficiency dust/mist filter may be worn up to 50 times the exposure limit or the maximum use concentration specified by the regulatory agency or respirator supplier, whichever is lowest. For emergencies or instances where the exposure levels are not known, use a full-facepiece positive-pressure supplied air respirator. **WARNING: Air purifying respirators do not protect workers in oxygen-deficient atmospheres. Maintain airborne contaminant concentrations below exposure limits given above. If respiratory protection is needed, use only protection authorized in 29 CFR 1910.134, European Standard EN 149, or applicable State regulations. If adequate ventilation is not available or there is potential for airborne exposure above the exposure limits, a respirator may be worn up to the respirator exposure limitations, check with respirator equipment manufacturer's recommendations/limitations. For a higher level of protection, use positive pressure supplied air respiration protection or Self-Contained Breathing Apparatus or if oxygen levels are below 19.5% or are unknown.**

**EMERGENCY OR PLANNED ENTRY INTO UNKNOWN CONCENTRATIONS OR IDLH CONDITIONS**

Positive pressure, full-face piece Self-Contained Breathing Apparatus; or positive pressure, full-face piece Self-Contained Breathing Apparatus with an auxiliary positive pressure Self-Contained Breathing Apparatus.

**VENTILATION**

LOCAL EXHAUST: Necessary  
 SPECIAL: None  
 MECHANICAL (GENERAL): Necessary  
 OTHER: None  
 Please refer to ACGIH document, "Industrial Ventilation, A Manual of Recommended Practices", most recent edition, for details.

**8.3 INDIVIDUAL PROTECTION MEASURES, SUCH AS PERSONAL PROTECTIVE EQUIPMENT:**

**EYE PROTECTION:**

Splash goggles or safety glasses. Face-shields are recommended when the operation can generate splashes, sprays or mists.

**HAND PROTECTION:**

Use gloves chemically resistant to this material. Preferred examples: Butyl rubber, Chlorinated Polyethylene, Polyethylene, Ethyl vinyl alcohol laminate ("EVAL"), Polyvinyl alcohol ("PVA"). Examples of acceptable glove barrier materials include: Natural rubber ("latex"), Neoprene, Nitrile/butadiene rubber ("nitril" or "NBR"), Polyvinyl chloride ("PVC") or "vinyl"), Viton. NOTICE: The selection of a specific glove for a particular application and duration of use in a workplace should also take into account all relevant workplace factors such as, but not limited to: Other chemicals which may be handled, physical requirements (cut/puncture protection, dexterity, thermal protection), potential body reactions to glove materials, as well as the instructions/specifications provided by the glove supplier.

**BODY PROTECTION:**

Use body protection appropriate for task. Cover-all, rubber aprons, or chemical protective clothing made from impervious materials are generally acceptable, depending on the task.

**WORK & HYGIENIC PRACTICES:**

Provide readily accessible eye wash stations & safety showers. Wash at end of each shift & before eating, smoking or using the toilet. Remove clothing that becomes contaminated. Destroy contaminated leather articles. Launder or discard contaminated clothing.

**SECTION 9. PHYSICAL & CHEMICAL PROPERTIES**

APPEARANCE:	Fuming Liquid, Water-White to Light Yellow
ODOR:	Sharp, acid
ODOR THRESHOLD:	Not Available
pH (Neutrality):	0.0
MELTING POINT/FREEZING POINT:	Not Available
BOILING RANGE (IBP,50%,Dry Point):	80 100 105 C / 176 212 221 F
FLASH POINT (TEST METHOD):	Not Applicable
EVAPORATION RATE (n-Butyl Acetate=1):	0.319
FLAMMABILITY CLASSIFICATION:	Non-Combustible
LOWER FLAMMABLE LIMIT IN AIR (% by vol):	Not Applicable
UPPER FLAMMABLE LIMIT IN AIR (% by vol):	Not Available
VAPOR PRESSURE (mm of Hg)@20 C	17.0
VAPOR DENSITY (air=1):	0.802
GRAVITY @ 68/68 F / 20/20 C:	
DENSITY:	1.055 (10%); 1.150 (30%)
SPECIFIC GRAVITY (Water=1):	1.057 (10%); 1.152 (30%)
POUNDS/GALLON:	8.805 (10%); 9.596 (30%)
WATER SOLUBILITY:	Complete
PARTITION COEFFICIENT (n-Octane/Water):	Not Available
AUTO IGNITION TEMPERATURE:	Not Applicable
DECOMPOSITION TEMPERATURE:	Not Available
TOTAL VOC'S (TVOC)*:	0.0 Vol% /0.0 g/L / 0.000 Lbs/Gal
NONEXEMPT VOC'S (CVOC)*:	0.0 Vol% /0.0 g/L / 0.000 Lbs/Gal
HAZARDOUS AIR POLLUTANTS (HAPS):	31.0 Wt% / 322 g/L / 2.7 Lbs/Gal
NONEXEMPT VOC PARTIAL PRESSURE (mm of Hg @ 20 C)	0.0
VISCOSITY @ 20 C (ASTM D445):	Not Available

\* Using CARB (California Air Resources Board Rules).

**SECTION 10. STABILITY & REACTIVITY**

**10.1 REACTIVITY & CHEMICAL STABILITY:**

Stable under ordinary usage. Hydrogen chloride is a highly corrosive and toxic colorless gas that forms white fumes on contact with humidity. These fumes consist of hydrochloric acid which forms when hydrogen chloride dissolves in water.

**10.2 POSSIBILITY OF HAZARDOUS REACTIONS & CONDITIONS TO AVOID:**

Highly reactive with strong bases, metals, metal oxides, hydroxides, amines, carbonates and alkaline materials. Incompatible with cyanide, sulfides, sulfites, and formaldehyde.

**10.3 INCOMPATIBLE MATERIALS:**

The substance is a strong acid, reacts violently with strong bases causing fire & explosion hazard. Attacks many metals, forming flammable/explosive (hydrogen) gas.

**10.4 HAZARDOUS DECOMPOSITION PRODUCTS:**

When heated to decomposition, fumes will react with water or steam to produce heat and toxic, corrosive fumes. Thermal decomposition in the presence of oxidizing materials produces toxic chlorine fumes and explosive hydrogen gas.



## 10.5 HAZARDOUS POLYMERIZATION:

Will not occur.

**SECTION 11. TOXICOLOGICAL INFORMATION****11.1 ACUTE HAZARDS****11.1.1 EYE & SKIN CONTACT:**

Hydrochloric acid is corrosive to the eyes, skin, and mucous membranes. Causes severe burns to skin as well as defatting, dermatitis, and ulceration.

**11.1.2 EYE CONTACT:**

Severe burns to eyes causing redness, tearing, and blurred vision.

**11.1.3 INHALATION:**

Inhalation exposure may cause eye, nose, and respiratory tract irritation, inflammation, and pulmonary edema in humans.

**11.1.4 SWALLOWING:**

Harmful or fatal if swallowed. Oral exposure may cause corrosion of the mucous membranes, esophagus, and stomach. The symptoms of chemical pneumonitis may not show up for a few days.

**11.2 SUBCHRONIC HAZARDS/CONDITIONS AGGRAVATED****CONDITIONS AGGRAVATED**

Persons with severe skin, liver or kidney problems should avoid use.

**11.3 CHRONIC HAZARDS****11.3.1 CANCER, REPRODUCTIVE & OTHER CHRONIC HAZARDS:**

Chronic occupational exposure to hydrochloric acid has been reported to cause gastritis, chronic bronchitis, dermatitis, and photosensitization in workers. Prolonged exposure to low concentrations may also cause dental discoloration and erosion.

This product has no carcinogens listed by IARC, NTP, NIOSH, OSHA or ACGIH, as of this date, greater or equal to 0.1%.

**11.3.2 TARGET ORGANS:** May cause damage to target organs.**11.3.3 IRRITANCY OF PRODUCT:** This product is corrosive to contaminated tissue. Chronic inhalation exposure caused hyperplasia of the nasal mucosa, larynx, and trachea and lesions in the nasal cavity in rats.**11.3.4 SENSITIZATION TO THE PRODUCT:** Long-term exposure of hydrochloric acid may cause photosensitization in workers.**11.3.5 MUTAGENICITY:** No known reports of mutagenic effects in humans.**11.3.6 EMBRYOTOXICITY:** No known reports of embryotoxic effects in humans.**11.3.7 TERATOGENICITY:** No known reports of teratogenic effects in humans.**11.3.8 REPRODUCTIVE TOXICITY:** No known reports of reproductive effects in humans. In rats exposed to hydrochloric acid by inhalation, severe dyspnea, cyanosis, and altered estrus cycles have been reported in dams, and increased fetal mortality and decreased fetal weight have been reported in the offspring.

A mutagen is a chemical which causes permanent changes to genetic material (DNA) such that the changes will propagate through generational lines. An embryotoxin is a chemical which causes damage to a developing embryo (such as: within the eight weeks of pregnancy in humans), but the damage does not propagate across generational lines. A teratogen is a chemical which causes damage to a developing fetus, but the damage does not propagate across generational lines. A reproductive toxin is any substance which interferes in any way with the reproductive process.

**11.4 MAMMALIAN TOXICITY INFORMATION**

Animal	Exposure Route	LC50
Rat	Inhalation	3124 ppm/1 hr, 4701 ppm/30 min (Hydrogen Chloride Gas)
Rat	Oral	238-277 mg/kg, 7.8 mL/kg/ 3.3% HCl in water (female rat)
Mouse	Inhalation	1108 ppm/1 hr, 2644 ppm/30 min (Hydrogen Chloride Gas)

Mouse	Dermal	1449 mg/kg
Guinea Pig	Inhalation	4.3 mg/L/15min, 2.0mg/L/30min

**SECTION 12. ECOLOGICAL INFORMATION**

**12.1 ALL WORK PRACTICES MUST BE AIMED AT ELIMINATING ENVIRONMENTAL CONTAMINATION.**

**12.2 EFFECT OF MATERIAL ON PLANTS AND ANIMALS:**

This product may be harmful or fatal to plant and animal life if released into the environment. Refer to Section 11 (Toxicological Information) for further data on the effects of this product's components on test animals.

**12.3 EFFECT OF MATERIAL ON AQUATIC LIFE:**

LC50 / 48 hours:                      3.6 mg/L (Bluegill Sunfish)

**12.4 MOBILITY IN SOIL**

This material is a mobile liquid. Transport through soil may contaminate ground water and dissolve soil materials.

**12.5 DEGRADABILITY**

This product is biodegradable.

**12.6 ACCUMULATION**

This product does not accumulate or biomagnify in the environment.

**SECTION 13. DISPOSAL CONSIDERATIONS**

The generation of waste should be avoided or minimized wherever possible. Dispose of surplus and non-recyclable products via a licensed waste disposal contractor. Waste should not be disposed of untreated to the sewer unless fully compliant with the requirements of all authorities with jurisdiction. Waste packaging should be recycled. Incineration or landfill should only be considered when recycling is not feasible. This material and its container must be disposed of in a safe way. Care should be taken when handling emptied containers that have not been cleaned or rinsed out. Empty containers and liners may retain some product residues. Vapor from some product residues may create a highly flammable or explosive atmosphere inside the container. Do not cut, weld or grind used containers unless they have been cleaned thoroughly internally. Avoid dispersal of spilled material and runoff and contact with soil, waterways, drains and sewers. Processing, use or contamination may change the waste disposal requirements. Do not dispose of on land, in surface waters, or in storm drains. Waste should be recycled or disposed of in accordance with regulations. Large amounts should be collected for reuse or consigned to licensed hazardous waste haulers for disposal. **ALL DISPOSAL MUST BE IN ACCORDANCE WITH ALL FEDERAL, STATE, PROVINCIAL, AND LOCAL REGULATIONS. IF IN DOUBT, CONTACT PROPER AGENCIES. EPA CHARACTERISTIC: D002**

**SECTION 14. TRANSPORT INFORMATION**

MARINE POLLUTANT: No  
 DOT/TDG SHIP NAME: UN1789, Hydrochloric acid, 8, PG-II  
 DRUM LABEL: (CORROSIVE)  
 IATA / ICAO: UN1789, Hydrochloric acid, 8, PG-II  
 IMO / IMDG: UN1789, Hydrochloric acid, 8, PG-II  
 EMERGENCY RESPONSE GUIDEBOOK NUMBER: 157

**SECTION 15. REGULATORY INFORMATION**

**15.1 EPA REGULATION:**

**SARA SECTION 311/312 HAZARDS: Acute Health**

All components of this product are on the TSCA list.

SARA Title III Section 313 Supplier Notification

This product contains the indicated <\*> toxic chemicals subject to the reporting requirements of Section 313 of the Emergency Planning & Community Right-To-Know Act of 1986 & of 40 CFR 372. This information must be included in all MSDSs that are copied and distributed for this material.

SARA TITLE III INGREDIENTS	CAS#	EINECS#	(REG. SECTION)	RQ(LBS)
*Hydrochloric Acid	7647-01-0	231-595-7	(302,311,312,)	5000

Any release equal to or exceeding the RQ must be reported to the National

COMPANY IDENTITY: Cascade Columbia Distribution Company      SDS DATE: 02/12/2019  
PRODUCT IDENTITY: MURIATIC ACID (TECHNICAL GRADE) 30-35%      ORIGINAL DATE: 03/25/2015  
Response Center (800-424-8802) and appropriate state and local regulatory agencies as described in 40 CFR 302.6 and 40 CFR 355.40 respectively.  
Failure to report may result in substantial civil and criminal penalties.  
State & local regulations may be more restrictive than federal regulations.

#### 15.2 STATE REGULATIONS:

CALIFORNIA SAFE DRINKING WATER & TOXIC ENFORCEMENT ACT (PROPOSITION 65):  
This product contains no chemicals known to the State of California to cause cancer or reproductive toxicity.

#### 15.3 INTERNATIONAL REGULATIONS

The identified components of this product are listed on the chemical inventories of the following countries:  
Australia (AICS), Canada (DSL or NDSL), China (IECSC), Europe (EINECS, ELINCS), Japan (METI/CSCL, MHLW/ISHL), South Korea (KECI), New Zealand (NZIoC), Philippines (PICCS), Switzerland (SWISS), Taiwan (NECSI), USA (TSCA).

#### 15.4 CANADA: WORKPLACE HAZARDOUS MATERIALS INFORMATION SYSTEM (WHMIS)

D2B: Irritating to skin / eyes.  
E: Corrosive Material.

This product has been classified in accordance with hazard criteria of the Controlled Products Regulations (CPR) and the SDS contains all information required by the CPR.

### SECTION 16. OTHER INFORMATION

#### 16.1 HAZARD RATINGS:

HEALTH (NFPA): 3, HEALTH (HMIS): 3, FLAMMABILITY: 0, PHYSICAL HAZARD: 0  
(Personal Protection Rating to be supplied by user based on use conditions.)  
This information is intended solely for the use of individuals trained in the NFPA & HMIS hazard rating systems.

#### 16.2 EMPLOYEE TRAINING

See Section 2 for Risk & Safety Statements. Employees should be made aware of all hazards of this material (as stated in this SDS) before handling it.

#### 16.3 SDS DATE: 02/12/2019

#### NOTICE

The supplier disclaims all expressed or implied warranties of merchantability or fitness for a specific use, with respect to the product or the information provided herein, except for conformation to contracted specifications. All information appearing herein is based upon data obtained from manufacturers and/or recognized technical sources. While the information is believed to be accurate, we make no representations as to its accuracy or sufficiency. Conditions of use are beyond our control, and therefore users are responsible for verifying the data under their own operating conditions to determine whether the product is suitable for their particular purposes and they assume all risks of their handling, and disposal of the product. Users also assume all risks in regards to the publication or use of, or reliance upon information contained herein. This information relates only to the product designated herein, and does not relate to its use in combination with any other material or process.



< Business Lookup

### License Information:

[New search](#) [Back to results](#)

**Entity name:** OXARC, LLC

**Business name:** OXARC, LLC

**Entity type:** [Limited Liability Company](#)

**UBI #:** 328-037-121

**Business ID:** 001

**Location ID:** 0015

**Location:** Active

**Location address:** 4003 E BROADWAY AVE  
SPOKANE WA 99202-4528

**Mailing address:** PO BOX 3031  
SPOKANE WA 99220-3031

**Excise tax and reseller permit status:** [Click here](#)

**Secretary of State status:** [Click here](#)

### Endorsements

Endorsements held at this location	License #	Count	Details	Status	Expiration date	First issuance date
<a href="#">Spokane General Business</a>				Active	Sep-30-2025	Aug-07-2015

### Governing People May include governing people not registered with Secretary of State

Governing people	Title
FITZGERALD, JENNA	

### Registered Trade Names

Registered trade names	Status	First issued
OXARC	Active	Sep-25-1989

[View Additional Locations](#)

The Business Lookup information is updated nightly. Search date and time: 10/7/2024 8:19:45 AM

[Contact us](#)

[How are we doing?](#)  
[Take our survey!](#)

[Don't see what you expected?](#)  
[Check if your browser is supported](#)





< Business Lookup

### License Information:

[New search](#) [Back to results](#)

**Entity name:** OXARC, LLC

**Business name:** OXARC, LLC

**Entity type:** [Limited Liability Company](#)

**UBI #:** 328-037-121

**Business ID:** 001

**Location ID:** 0015

**Location:** Active

**Location address:** 4003 E BROADWAY AVE  
SPOKANE WA 99202-4528

**Mailing address:** PO BOX 3031  
SPOKANE WA 99220-3031

**Excise tax and reseller permit status:** [Click here](#)

**Secretary of State status:** [Click here](#)

### Endorsements

Endorsements held at this location	License #	Count	Details	Status	Expiration date	First issuance date
<a href="#">Spokane General Business</a>				Active	Sep-30-2025	Aug-07-2015

### Governing People May include governing people not registered with Secretary of State

Governing people	Title
FITZGERALD, JENNA	

### Registered Trade Names

Registered trade names	Status	First issued
OXARC	Active	Sep-25-1989

[View Additional Locations](#)

The Business Lookup information is updated nightly. Search date and time: 10/7/2024 8:19:45 AM

[Contact us](#)

[How are we doing?](#)  
[Take our survey!](#)

Don't see what you expected?  
[Check if your browser is supported](#)



**Agenda Sheet for City Council:****Committee:** PIES **Date:** 10/21/2024**Committee Agenda type:** Consent**Date Rec'd** 10/22/2024**Clerk's File #** OPR 2022-0901**Cross Ref #****Project #****Council Meeting Date:** 11/04/2024**Submitting Dept** SOLID WASTE DISPOSAL**Bid #** ITB 5754-22**Contact Name/Phone** DAVID PAINE 625-6878**Requisition #** VB 301414**Contact E-Mail** DPAINE@SPOKANECITY.ORG**Agenda Item Type** Purchase w/o Contract**Council Sponsor(s)** BWILKERSON JBINGLE KKLITZKE**Agenda Item Name** 4490-VALUE BLANKET RENEWAL FOR THE PURCHASE OF SUPERHEATER TUBE**Agenda Wording**

Value blanket renewal 2 of 4 with Helfrich Brothers Boiler Works, Inc. (Lawrence, MA) for the purchase of superheater tube panels for use at the Waste to Energy Facility from 12/15/2024-12/14/2025 and a total cost not to exceed \$3,750,000.00 plus tax

**Summary (Background)**

The superheater section of a boiler increases the temperature of steam and dries it out; increasing the energy realized in a turbine generator. High temps and corrosion cause wear on the boiler tubes, requiring periodic replacement. This is currently scheduled in 2026, requiring a tube order to be placed in 2024. Helfrich Brothers was the low-cost bidder for ITB 5754-22 for the purchase of these tubes and awarded a one year value blanket with four renewals. This will be the second renewal.

Lease? NO Grant related? NO Public Works? NO

**Fiscal Impact**

Approved in Current Year Budget?

Total Cost \$ 3,750,000.00

Current Year Cost \$ 0

Subsequent Year(s) Cost \$ 0

**Narrative**

This is a capital repair and maintenance expense that was planned for in the Solid Waste Disposal capital plan and budget.

**Amount****Budget Account**

Expense \$ 1,875,000.00 # 4490-44900-37145-54803-19047

Expense \$ 1,875,000.00 # 4490-44900-37145-54803-19048

Select \$ #

Select \$ #

\$ #

\$ #



**Continuation of Wording, Summary, Approvals, and Distribution**

**Agenda Wording**

**Summary (Background)**

**Approvals**

**Dept Head**

AVERYT, CHRIS

**Division Director**

FEIST, MARLENE

**Accounting Manager**

ALBIN-MOORE, ANGELA

**Legal**

SCHOEDEL, ELIZABETH

**For the Mayor**

PICCOLO, MIKE

**Additional Approvals**

**PURCHASING**

PRINCE, THEA

**Distribution List**

mdorgan@spokanecity.org

jsalstrom@spokanecity.org

tprince@spokanecity.org

rrinderle@spokanecity.org

## Committee Agenda Sheet

### Public Infrastructure, Environment & Sustainability Committee

<b>Committee Date</b>	October 21, 2024
<b>Submitting Department</b>	Solid Waste Disposal
<b>Contact Name</b>	David Paine
<b>Contact Email &amp; Phone</b>	<a href="mailto:dpaine@spokanecity.org">dpaine@spokanecity.org</a> , 509-625-6878
<b>Council Sponsor(s)</b>	Wilkerson, Bingle, Klitzke
<b>Select Agenda Item Type</b>	<input checked="" type="checkbox"/> Consent <input type="checkbox"/> Discussion    Time Requested:
<b>Agenda Item Name</b>	Value blanket renewal for the purchase of superheater tubes at the Waste to Energy Facility
<b>Proposed Council Action</b>	<input checked="" type="checkbox"/> Approval to proceed to Legislative Agenda <input type="checkbox"/> Information Only
<b>Summary (Background)</b>  *use the Fiscal Impact box below for relevant financial information	<p>The superheater section of a boiler increases the temperature of the steam and dries it out; increasing the amount of energy realized in the turbine generator. High temperatures, corrosion, and erosion in the boiler causes wear on the boiler tubes, requiring periodic replacement. This periodic replacement is currently scheduled in the six year capital plan for replacement in 2026.</p> <p>On October 24, 2022, bidding closed on ITB 5754-22 for the fabrication of these superheater tube panels. There were two responses to the bid, of which Helfrich Brothers Boiler Works, Inc., of Lawrence, MA was the lowest cost responsible bidder.</p> <p>The initial value blanket was for one-year, with the possibility of four (4) additional one-year renewals. This will be the second renewal and will be utilized for the purchase of the primary superheater pendants in 2025, which are scheduled for replacement in 2026. The term will be from December 15, 2024 through December 14, 2025. The installation of these tubes will be bid out separately. The total cost of the value blanket will be \$3,750,000.00, plus tax.</p>
<b>Fiscal Impact</b>	
<b>Approved in current year budget?</b> <input checked="" type="checkbox"/> Yes <input type="checkbox"/> No <input type="checkbox"/> N/A	
Total Cost: <u>\$3,750,000.00</u>	
Current year cost: 0	
Subsequent year(s) cost: 0	
<b>Narrative:</b> <u>This is a capital repair and maintenance expense that was planned for in the Solid Waste Disposal capital plan and budget.</u>	
<b>Funding Source</b> <input type="checkbox"/> One-time <input checked="" type="checkbox"/> Recurring <input type="checkbox"/> N/A	
Specify funding source: Program revenue	
Is this funding source sustainable for future years, months, etc? Yes	
<b>Expense Occurrence</b> <input checked="" type="checkbox"/> One-time <input type="checkbox"/> Recurring <input type="checkbox"/> N/A	
Other budget impacts: (revenue generating, match requirements, etc.)	



**Operations Impacts** (If N/A, please give a brief description as to why)

- What impacts would the proposal have on historically excluded communities?  
Public works services and projects are designed to serve all citizens and businesses. We strive to offer a consistent level of service to all, to distribute public investment throughout the community and to respond to gaps in services identified in various City plans.
- How will data be collected, analyzed, and reported concerning the effect of the program/policy by racial, ethnic, gender identity, national origin, income level, disability, sexual orientation, or other existing disparities?  
N/A
- How will data be collected regarding the effectiveness of this program, policy, or product to ensure it is the right solution?  
Public Works follows the City's established procurement and public works bidding regulations and policies to bring items forward, and then uses contract management best practices to ensure desired outcomes and regulatory compliance.
- Describe how this proposal aligns with current City Policies, including the Comprehensive Plan, Sustainability Action Plan, Capital Improvement Program, Neighborhood Master Plans, Council Resolutions, and others?  
This work is consistent with annual budget strategies to limit costs and approved projects in the 6-year CIP.

**Council Subcommittee Review**

- Please provide a summary of council subcommittee review. If not reviewed by a council subcommittee, please explain why not.

Not applicable

Value Blanket VB-301414		Base Year	1st Opt Year	2nd Opt Year
		VB-301414-000	VB-301414-001	VB-301414-002
		Valid from 12/15/2022 Through 14/14/2023	Valid from 12/15/2023 Through 12/14/2024	Valid from 12/15/2024 Through 12/14/2025
		Unit Price Each	Unit Price Each	Unit Price Each
Item	Qty 1 Lot More Or Less	All Ground FREIGHT CHARGES are the responsibility of the winning supplier per bid ITB 5754-23	All Ground FREIGHT CHARGES are the responsibility of the winning supplier per bid ITB 5754-23	All Ground FREIGHT CHARGES are the responsibility of the winning supplier per bid ITB 5754-23
Fabrication of thirty-two (32) 20-tube wide secondary Superheater pendants fitted with 310 SS rapper bars referenced in item 3 below to be delivered on or before October 30, 2023. The tube material will consist of 2" OD x .240 mwt, SA-213-TP310H on the first four (4) rows and 2 1/2" OD x .240 mwt, SA-213-TP310H on the next sixteen (16) rows. On row# 4, just above the middle slip spacer, a swaged stainless steel tube from 2" to 2 1/2" will be installed. A total of (19) 310 SS slip spacers will be installed in the middle section of each Superheater pendant and (10) 310 SS slip spacers will be installed in the upper section. The slips spacers will be the "D" type and cast from SA-351 CK 30 stainless steel. Both terminal tubes will have SA 210A1 "safe ends" installed to match existing. Comprising one lot. Quantity 1 Lot, More or less. All FREIGHT CHARGES are the responsibility of the winning supplier. Unit Pricing Should Not Include Tax.	1	\$1,281,390.00	\$1,383,910.00	\$1,488,000.00
Fabrication of thirty-four (34) 20-tube wide primary Superheater pendants fitted with 310 SS rapper bars referenced in item 4 below to be delivered during an agreed time in the duration of the contract. The tube material will consist of 2" OD x .240 mwt, SA-213-TP310H on the first four (4) rows and 2 1/2" OD x .240 mwt, SA-213-TP310H on the next sixteen (16) rows. On row# 4, just above the middle slip spacer, a swaged stainless steel tube from 2" to 2 1/2" will be installed. A total of (19) 310 SS slip spacers will be installed in the middle section of each Superheater pendant and (10) 310 SS slip spacers will be installed in the upper section. The slips spacers will be the "D" type and cast from SA-351 CK 30 stainless steel. Both terminal tubes will have SA 210A1 "safe ends" installed to match existing. All FREIGHT CHARGES are the responsibility of the winning supplier. Unit Pricing Should Not Include Tax.	1	\$1,361,475.00	\$1,470,395.00	\$1,581,000.00
Fabrication of thirty-four (32) sets of 310 SS rapper bars including rapper caps and SS hardware for the secondary pendants to be delivered during an agreed time in the duration of the contract. The rapper bars will be machined to fit vs. a casting type and shop installed. Winning bidder will provide a complete set of rapper bar drawings for the project. Comprising one lot. Quantity 1 Lot, More or less. All FREIGHT CHARGES are the responsibility of the winning supplier. Unit Pricing Should Not Include Tax.	1	\$159,845.00	\$172,635.00	\$185,600.00
Fabrication of thirty-four (34) sets of 310 SS rapper bars including rapper caps and SS hardware for the primary pendants to be delivered during an agreed time in the duration of the contract. The rapper bars will be machined to fit vs. a casting type and shop installed. Winning bidder will provide a complete set of rapper bar drawings for the project. Comprising one lot. Quantity 1 Lot, More or less. Unit Pricing Should Not Include Tax.	1	\$169,640.00	\$183,215.00	\$197,200.00
Materials, engineering and fabrication of two (2) complete sets of Penthouse Casing and Seal Plates per the provided drawings. Comprising one lot. Quantity 1 Lot, More or less. All FREIGHT CHARGES are the responsibility of the winning supplier. Unit Pricing Should Not Include Tax.	1	\$38,000.00	\$41,040.00	\$44,000.00
Option Supply and install 1 OGA 310SS 2 1/2" 180 degree tube shields, applied to row #20 on the upper third of the pendant and the middle sections. clips will be installed in (3) location. A total of 16 LF of coverage per pendant will be included in this option. Comprising one lot. Quantity 1 Lot, More or less. All FREIGHT CHARGES are the responsibility of the winning supplier. Unit Pricing Should Not Include Tax.	1	\$22,000.00	\$23,760.00	\$25,000.00
Option Supply and install 1 OGA 310SS 2" 180 degree tube shields, applied to row# 1 from just below the top bend the complete length of the pendant and around the lower tube bend and up 1 ft. on tube #4. Tube shields shall have clips installed in (3) location. A total of 35 LF of coverage per pendant will be included in the option. Shields shall have clips will be installed in (3) location. A total of 16 LF of coverage per pendant will be included in this option. Comprising one lot. Quantity 1 Lot, More or less. All FREIGHT CHARGES are the responsibility of the winning supplier. All FREIGHT CHARGES are the responsibility of the winning supplier. Unit Pricing Should Not Include Tax.	1	\$25,000.00	\$27,000.00	\$29,000.00
Percentage discount off list to be provided by Supplier for additional tube related items not listed in the Pricing tab but may be realized are needed at a later point in time. Enter Percentage Discount Off Supplier's List Cost.		5% Discount	5% Discount	5% Discount
Should Supplier not provide percentage off discount for additional tube related items not listed in the Pricing tab but may be realized are needed at a later point in time, Supplier shall provide Percentage Markup Above Supplier's Cost. Enter Percentage Markup Above Supplier cost here.		25% Markup	25% Markup	25% Markup
Vendor to provide discount percentage(s) and minimum quantity needed if any discounts apply based on order volume.		Any additional quantities over the original requirements HBBW will offer an 5% discount on the list pricing. This assume normal	Any additional quantities over the original requirements HBBW will offer an 5% discount on the list pricing. This assume normal	Any additional quantities over the original requirements HBBW will offer an 5% discount on the list pricing. This assume normal
Percentage discount off list to be provided by vendor for additional tube related items not listed in the Pricing tab but may be realized are needed at a later point in time.		HBBW will offer an 5% discount on the list pricing. This assume normal shipping	HBBW will offer an 5% discount on the list pricing. This assume normal shipping	HBBW will offer an 5% discount on the list pricing. This assume normal shipping
O: 978-683-7244   C: 781-636-8644 Helfrich Brothers Boiler Works, Inc.		Base Year Pricing Was Per HBBW's Response to ITB 5754-23	Name Signature Date	Name Signature Date Chris Sylvia  9-30-24



< Business Lookup

### License Information:

[New search](#) [Back to results](#)

**Entity name:** HELFRICH BROS BOILER WORKS, INC.

**Business name:** HELFRICH BROS BOILER WORKS INC

**Entity type:** [Profit Corporation](#)

**UBI #:** 603-344-193

**Business ID:** 001

**Location ID:** 0001

**Location:** Active

**Location address:** 39 MERRIMACK ST  
LAWRENCE MA 01843-1436

**Mailing address:** 39 MERRIMACK ST  
LAWRENCE MA 01843-1436

**Excise tax and reseller permit status:** [Click here](#)

**Secretary of State status:** [Click here](#)

### Endorsements

Endorsements held at this location	License #	Count	Details	Status	Expiration date	First issuance date
<a href="#">Spokane General Business - Non-Resident</a>				Active	Mar-31-2025	Dec-13-2013

### Governing People May include governing people not registered with Secretary of State

Governing people	Title
HELFRICH JR, VINCENT	
HELFRICH, JOSEPH	

### Registered Trade Names

Registered trade names	Status	First issued
HELFRICH BROS BOILER WORKS INC	Active	Dec-13-2013

The Business Lookup information is updated nightly. Search date and time: 10/9/2024 10:02:15 AM

[Contact us](#)

How are we doing?  
[Take our survey!](#)

Don't see what you expected?  
[Check if your browser is supported](#)





< Business Lookup

### License Information:

[New search](#) [Back to results](#)

**Entity name:** HELFRICH BROS BOILER WORKS, INC.

**Business name:** HELFRICH BROS BOILER WORKS INC

**Entity type:** [Profit Corporation](#)

**UBI #:** 603-344-193

**Business ID:** 001

**Location ID:** 0001

**Location:** Active

**Location address:** 39 MERRIMACK ST  
LAWRENCE MA 01843-1436

**Mailing address:** 39 MERRIMACK ST  
LAWRENCE MA 01843-1436

**Excise tax and reseller permit status:** [Click here](#)

**Secretary of State status:** [Click here](#)

### Endorsements

Endorsements held at this location	License #	Count	Details	Status	Expiration date	First issuance date
<a href="#">Spokane General Business - Non-Resident</a>				Active	Mar-31-2025	Dec-13-2013

### Governing People May include governing people not registered with Secretary of State

Governing people	Title
HELFRICH JR, VINCENT	
HELFRICH, JOSEPH	

### Registered Trade Names

Registered trade names	Status	First issued
HELFRICH BROS BOILER WORKS INC	Active	Dec-13-2013

The Business Lookup information is updated nightly. Search date and time: 10/9/2024 10:02:15 AM

[Contact us](#)

How are we doing?  
[Take our survey!](#)

Don't see what you expected?  
[Check if your browser is supported](#)





# CERTIFICATE OF LIABILITY INSURANCE

DATE (MM/DD/YYYY)

05/31/2024

THIS CERTIFICATE IS ISSUED AS A MATTER OF INFORMATION ONLY AND CONFERS NO RIGHTS UPON THE CERTIFICATE HOLDER. THIS CERTIFICATE DOES NOT AFFIRMATIVELY OR NEGATIVELY AMEND, EXTEND OR ALTER THE COVERAGE AFFORDED BY THE POLICIES BELOW. THIS CERTIFICATE OF INSURANCE DOES NOT CONSTITUTE A CONTRACT BETWEEN THE ISSUING INSURER(S), AUTHORIZED REPRESENTATIVE OR PRODUCER, AND THE CERTIFICATE HOLDER.

**IMPORTANT:** If the certificate holder is an **ADDITIONAL INSURED**, the policy(ies) must have **ADDITIONAL INSURED** provisions or be endorsed. If **SUBROGATION IS WAIVED**, subject to the terms and conditions of the policy, certain policies may require an endorsement. A statement on this certificate does not confer rights to the certificate holder in lieu of such endorsement(s).

<b>PRODUCER</b> Cleary Insurance Inc 226 Causeway Street  Boston MA 02114-2155		<b>CONTACT NAME:</b> Ruth Resca <b>PHONE (A/C, No, Ext):</b> (617) 723-0700 <b>E-MAIL ADDRESS:</b> rresca@clearyinsurance.com		<b>FAX (A/C, No):</b> (617) 723-7275
<b>INSURED</b>  Helfrich Brothers Boiler Works, Inc. 39 Merrimack Street  Lawrence MA 01843		<b>INSURER(S) AFFORDING COVERAGE</b>		<b>NAIC #</b>
		<b>INSURER A:</b> Admiral Insurance Company		24856
		<b>INSURER B:</b> Commerce Insurance Company		34754
		<b>INSURER C:</b> Starr Indemnity & Liability Company		38318
		<b>INSURER D:</b> Berkshire Hathaway Homestate Insurance Co.		20044
		<b>INSURER E:</b> Ironshore Specialty Insurance Company		25445
		<b>INSURER F:</b>		

**COVERAGES****CERTIFICATE NUMBER:** 2024-2025 Master Liabilit**REVISION NUMBER:**

THIS IS TO CERTIFY THAT THE POLICIES OF INSURANCE LISTED BELOW HAVE BEEN ISSUED TO THE INSURED NAMED ABOVE FOR THE POLICY PERIOD INDICATED. NOTWITHSTANDING ANY REQUIREMENT, TERM OR CONDITION OF ANY CONTRACT OR OTHER DOCUMENT WITH RESPECT TO WHICH THIS CERTIFICATE MAY BE ISSUED OR MAY PERTAIN, THE INSURANCE AFFORDED BY THE POLICIES DESCRIBED HEREIN IS SUBJECT TO ALL THE TERMS, EXCLUSIONS AND CONDITIONS OF SUCH POLICIES. LIMITS SHOWN MAY HAVE BEEN REDUCED BY PAID CLAIMS.

INSR LTR	TYPE OF INSURANCE	ADDL INSD	SUBR WVD	POLICY NUMBER	POLICY EFF (MM/DD/YYYY)	POLICY EXP (MM/DD/YYYY)	LIMITS	
A	<input checked="" type="checkbox"/> <b>COMMERCIAL GENERAL LIABILITY</b> <input type="checkbox"/> CLAIMS-MADE <input checked="" type="checkbox"/> OCCUR	Y	Y	CA-000042055-04	06/01/2024	06/01/2025	EACH OCCURRENCE	\$ 1,000,000
	DAMAGE TO RENTED PREMISES (Ea occurrence)						\$ 300,000	
	MED EXP (Any one person)						\$ 5,000	
	PERSONAL & ADV INJURY						\$ 1,000,000	
	GENERAL AGGREGATE						\$ 2,000,000	
GEN'L AGGREGATE LIMIT APPLIES PER: <input checked="" type="checkbox"/> POLICY <input type="checkbox"/> PRO-JECT <input type="checkbox"/> LOC OTHER:								
B	<input checked="" type="checkbox"/> <b>AUTOMOBILE LIABILITY</b> <input type="checkbox"/> ANY AUTO <input type="checkbox"/> OWNED AUTOS ONLY <input type="checkbox"/> HIRED AUTOS ONLY <input type="checkbox"/> SCHEDULED AUTOS <input type="checkbox"/> NON-OWNED AUTOS ONLY	Y	Y	L10664	06/01/2024	06/01/2025	COMBINED SINGLE LIMIT (Ea accident)	\$ 1,000,000
	BODILY INJURY (Per person)						\$	
	BODILY INJURY (Per accident)						\$	
	PROPERTY DAMAGE (Per accident)						\$	
C/F	<input type="checkbox"/> <b>UMBRELLA LIAB</b> <input checked="" type="checkbox"/> <b>EXCESS LIAB</b>	Y	Y	1000586389241/ BCS8800051	06/01/2024	06/01/2025	EACH OCCURRENCE	\$ 10,000,000
	<input type="checkbox"/> OCCUR <input type="checkbox"/> CLAIMS-MADE						AGGREGATE	\$ 10,000,000
DED RETENTION \$								
D	<b>WORKERS COMPENSATION AND EMPLOYERS' LIABILITY</b> ANY PROPRIETOR/PARTNER/EXECUTIVE OFFICER/MEMBER EXCLUDED? (Mandatory in NH) If yes, describe under DESCRIPTION OF OPERATIONS below	N/A	Y	HEWC524253	06/01/2024	06/01/2025	<input checked="" type="checkbox"/> PER STATUTE <input type="checkbox"/> OTHER	
	E.L. EACH ACCIDENT						\$ 1,000,000	
	E.L. DISEASE - EA EMPLOYEE						\$ 1,000,000	
DESCRIPTION OF OPERATIONS below								
E	Contractors Pollution Liability			ICELLUW00158980	06/01/2024	06/01/2025	Each Claim Limit	\$1,000,000
							Aggregate Limit	\$1,000,000

**DESCRIPTION OF OPERATIONS / LOCATIONS / VEHICLES (ACORD 101, Additional Remarks Schedule, may be attached if more space is required)**

PROFESSIONAL LIABILITY - INSURER G: Peleus Insurance Company NAIC# 34118 Pol No. 121 CTR 0213814-00 06/01/2024-06/01/2025 \$1,000,000 Ea Claim \$1,000,000 Aggregate  
City of Spokane Solid Waste Disposal is an additional insured when required by written contract. Coverage is primary noncontributory when required by written contract. Waiver of subrogation applies when required by written contract. Policy forms CG2010 12/19, CG2037 12/19, CG2404 05/09, CIC957 10-06, AD 6893 01/17 and WC000313. Umbrella coverage is follow form over General Liability, Auto Liability and Employers Liability. Per the cancellation clause contained in the policies noted on this certificate, the policy provisions include at least 30 days notice of cancellation except for non-payment of premium.

**CERTIFICATE HOLDER****CANCELLATION**

City of Spokane Solid Waste Disposal Attn: Michelle Dorgan 2900 S. Geiger Blvd. Spokane WA 99224	<b>SHOULD ANY OF THE ABOVE DESCRIBED POLICIES BE CANCELLED BEFORE THE EXPIRATION DATE THEREOF, NOTICE WILL BE DELIVERED IN ACCORDANCE WITH THE POLICY PROVISIONS.</b>  <b>AUTHORIZED REPRESENTATIVE</b> 
---	--

© 1988-2015 ACORD CORPORATION. All rights reserved.

AGENCY CUSTOMER ID: \_\_\_\_\_

LOC #: \_\_\_\_\_



# ADDITIONAL REMARKS SCHEDULE

Page \_\_\_\_ of \_\_\_\_

AGENCY Cleary Insurance Inc		NAMED INSURED Helfrich Brothers Boiler Works, Inc.	
POLICY NUMBER			
CARRIER	NAIC CODE	EFFECTIVE DATE:	

### ADDITIONAL REMARKS

**THIS ADDITIONAL REMARKS FORM IS A SCHEDULE TO ACORD FORM,**

**FORM NUMBER:** 25      **FORM TITLE:** Certificate of Liability Insurance: Notes

Certificate Holder and any other parties as required by written contract are Additional insured when required by written contract. Coverage is primary noncontributory when required by written contract. Waiver of subrogation applies when required by written contract. Policy forms CG2010 12/19, CG2037 12/19, CIC957 10-06, AD 6893 01/17 and WC000313. Umbrella coverage is follow form over General Liability, Auto Liability and Employers Liability.



**Agenda Sheet for City Council:**

**Committee:** PIES **Date:** 10/21/2024

**Committee Agenda type:** Consent

**Date Rec'd** 10/22/2024

**Clerk's File #** OPR 2020-0855

**Cross Ref #**

**Project #**

**Council Meeting Date:** 11/04/2024

<b>Submitting Dept</b>	SOLID WASTE DISPOSAL	<b>Bid #</b>	RFQ 5338-20
------------------------	----------------------	--------------	-------------

<b>Contact Name/Phone</b>	DAVID PAINE 625-6878	<b>Requisition #</b>	VB 301190
---------------------------	----------------------	----------------------	-----------

<b>Contact E-Mail</b>	DPAINE@SPOKANECITY.ORG		
-----------------------	------------------------	--	--

<b>Agenda Item Type</b>	Purchase w/o Contract		
-------------------------	-----------------------	--	--

<b>Council Sponsor(s)</b>	BWILKERSON JBINGLE KKLITZKE		
---------------------------	-----------------------------	--	--

<b>Agenda Item Name</b>	4490-VALUE BLANKET RENEWAL FOR BRIDGE CRANE REPLACEMENT PARTS		
-------------------------	---	--	--

**Agenda Wording**

Value blanket renewal 4 of 4 with WEMCO, Inc. (Spokane, WA) for the as-needed purchase of mechanical OEM parts for the refuse crane system at the Waste to Energy Facility from 12/1/2024-11/30/2025 and a total cost not to exceed \$160,000.00 plus tax.

**Summary (Background)**

In the event of a crane failure, a readily available supply of replacement parts need to be on hand. On October 15, 2020, bidding closed on RFQ 5338-20 for the as-needed purchase of new, OEM, mechanical replacement parts for the refuse crane system. WEMCO, Inc. was the only respondent. The initial value blanket award was for one year with the possibility of four (4) additional one-year renewals. This will be the final renewal.

Lease? NO Grant related? NO Public Works? NO

**Fiscal Impact**

Approved in Current Year Budget? YES

Total Cost \$ 160,000.00

Current Year Cost \$ 0

Subsequent Year(s) Cost \$ 0

**Narrative**

This is a routine repair and maintenance expense that was planned for in the Solid Waste Disposal budget. All funds are not typically utilized on this type of contract but need to be in place to avoid emergency spending in the event of equipment failures.

**Amount**

**Budget Account**

Expense	\$ 160,000.00	# 4490-44100-37148-53210-34002
---------	---------------	--------------------------------

Select	\$	#
--------	----	---

Select	\$	#
--------	----	---

Select	\$	#
--------	----	---

	\$	#
--	----	---

	\$	#
--	----	---



**Continuation of Wording, Summary, Approvals, and Distribution**

**Agenda Wording**

**Summary (Background)**

**Approvals**

<b><u>Dept Head</u></b>	AVERYT, CHRIS
<b><u>Division Director</u></b>	FEIST, MARLENE
<b><u>Accounting Manager</u></b>	ALBIN-MOORE, ANGELA
<b><u>Legal</u></b>	SCHOEDEL, ELIZABETH
<b><u>For the Mayor</u></b>	PICCOLO, MIKE

**Additional Approvals**

<b><u>PURCHASING</u></b>	PRINCE, THEA

**Distribution List**

	mdorgan@spokanecity.org
jsalstrom@spokanecity.org	tprince@spokanecity.org
rrinderle@spokanecity.org	



## Committee Agenda Sheet

### Public Infrastructure, Environment & Sustainability Committee

<b>Committee Date</b>	October 21, 2024
<b>Submitting Department</b>	Solid Waste Disposal
<b>Contact Name</b>	David Paine
<b>Contact Email &amp; Phone</b>	<a href="mailto:dpaine@spokanecity.org">dpaine@spokanecity.org</a> , 509-625-6878
<b>Council Sponsor(s)</b>	Wilkerson, Bingle, Klitzke
<b>Select Agenda Item Type</b>	<input checked="" type="checkbox"/> Consent <input type="checkbox"/> Discussion    Time Requested:
<b>Agenda Item Name</b>	Value blanket renewal for OEM bridge crane replacement parts
<b>Proposed Council Action</b>	<input checked="" type="checkbox"/> Approval to proceed to Legislative Agenda <input type="checkbox"/> Information Only
<b>Summary (Background)</b>  *use the Fiscal Impact box below for relevant financial information	<p>The Waste to Energy Facility replaced two bridge cranes with WEMCO brand cranes in 2017. To have a readily available supply of replacement parts on hand in the event of a failure, or for maintenance needs, an as-needed parts supplier is needed.</p> <p>On October 15, 2020 bidding closed on RFQ 5338-20 for the as-needed purchase of new, OEM, mechanical replacement parts for the refuse crane system. WEMCO Inc. (Spokane, WA) was the only response received. The value blanket award was for one year from December 1, 2020 through November 30, 2021 with the option of four (4) additional one-year renewals. This will be the final renewal and will span from December 1, 2024 through November 30, 2025, with a total cost not to exceed \$160,000.00 plus tax.</p>
<p><b>Fiscal Impact</b></p> <p><b>Approved in current year budget?</b>    <input checked="" type="checkbox"/> Yes    <input type="checkbox"/> No    <input type="checkbox"/> N/A</p> <p>Total Cost: <u>\$160,000.00 plus tax</u>  Current year cost: \$160,000.00  Subsequent year(s) cost: 0</p> <p><b>Narrative:</b> <u>This is a routine repair and maintenance supply expense that was planned for in the Solid Waste Disposal budget.</u></p> <p><b>Funding Source</b>    <input type="checkbox"/> One-time    <input checked="" type="checkbox"/> Recurring    <input type="checkbox"/> N/A  Specify funding source: Program revenue  Is this funding source sustainable for future years, months, etc? Yes</p> <p><b>Expense Occurrence</b>    <input type="checkbox"/> One-time    <input checked="" type="checkbox"/> Recurring    <input type="checkbox"/> N/A</p> <p>Other budget impacts: (revenue generating, match requirements, etc.)</p>	
<p><b>Operations Impacts (If N/A, please give a brief description as to why)</b></p> <ul style="list-style-type: none"> <li>What impacts would the proposal have on historically excluded communities?  Public works services and projects are designed to serve all citizens and businesses. We strive to offer a consistent level of service to all, to distribute public investment throughout the community and to respond to gaps in services identified in various City plans.</li> </ul>	

- How will data be collected, analyzed, and reported concerning the effect of the program/policy by racial, ethnic, gender identity, national origin, income level, disability, sexual orientation, or other existing disparities?  
N/A
- How will data be collected regarding the effectiveness of this program, policy, or product to ensure it is the right solution?  
Public Works follows the City's established procurement and public works bidding regulations and policies to bring items forward, and then uses contract management best practices to ensure desired outcomes and regulatory compliance.
- Describe how this proposal aligns with current City Policies, including the Comprehensive Plan, Sustainability Action Plan, Capital Improvement Program, Neighborhood Master Plans, Council Resolutions, and others?  
This work is consistent with annual budget strategies to limit costs and approved projects in the 6-year CIP.

**Council Subcommittee Review**

- Please provide a summary of council subcommittee review. If not reviewed by a council subcommittee, please explain why not.

Not applicable



**CITY OF SPOKANE - WTEF**  
 2900 S GEIGER BLVD  
 Spokane, Washington 99224-5400  
 PHONE: 509.625.6527

WEMCO		VB301190-000	VB301190-001	VB301190-002	VB301190-003	VB301190-004
Reference Bid RFQ 5165-19		Base Year	First Opt Year	Second Opt Year	Third Opt Year	Fourth Opt Year
New Spare Replacement Parts For Current Operating Refuse Crane System; As Needed - Annual Requirements		Valid from 12/01/2020 through 11/31/2021	Valid from 12/01/2021 through 11/31/2022	Valid from 12/01/2022 through 11/31/2023	Valid from 12/01/2023 through 11/31/2024	Valid from 12/01/2024 through 11/31/2025
MANUFACTURER	PART NUMBER	DESCRIPTION	Unit Price	Unit Price	Unit Price	Unit Price
WEMCO	318005-M-1003	Bridge Wheel	\$3,515.91	\$4,565.45	\$4,775.00	\$4,946.19
WEMCO	318005-M-1006	Bridge Wheel Axle (Non-Driven)	\$718.50	\$958.00	\$1,220.45	\$1,264.72
WEMCO	318005-M-1012	Bridge Wheel Axle (Driven)	\$1,417.98	\$1,890.64	\$2,493.59	\$2,584.03
WEMCO	318005-M-1001	Bridge End Truck Bearing Cap	\$1,086.06	\$1,448.06	\$1,574.00	\$1,764.57
WEMCO	318005-M-1002	Bridge End Truck Bearing Cap (Driven)	\$1,086.06	\$1,448.08	\$1,574.00	\$1,764.57
WEMCO	318005-M-3102	Trolley Wheel	\$2,833.52	\$3,985.45	\$4,138.34	\$4,288.44
WEMCO	318005-M-3106	Trolley Wheel Axle (Non-Driven)	\$596.78	\$795.71	\$904.22	\$1,050.47
WEMCO	318005-M-3107	Trolley Wheel Axle (Driven)	\$1,080.46	\$1,440.61	\$1,890.04	\$1,968.95
WEMCO	318005-M-3104	Trolley End Truck Bearing Cap	\$1,026.32	\$1,368.43	\$1,487.42	\$1,727.99
WEMCO	318005-M-3105	Trolley End Truck Bearing Cap	\$1,026.32	\$1,368.43	\$1,487.42	\$1,727.99
WEMCO	318005-P-3040L	Main Hoist Rope Guide Weldment End Bracket LH	\$509.96	\$679.95	\$715.74	No Bid, Removed From Crane
WEMCO	318005-P-3040R	Main Hoist Rope Guide Weldment End Bracket RH	\$509.96	\$679.95	\$715.74	No Bid, Removed From Crane
WEMCO	318005-M-4036	Main Hoist Equalizer Bar	\$930.30	\$1,240.40	\$1,528.11	\$1,583.53
WEMCO	318005-M-4020	Main Hoist Lower Sheave Pin	\$1,141.97	\$1,522.63	\$1,835.47	\$1,902.04
WEMCO	318005-M-4021	Main Hoist Lower Block Pin	\$588.27	\$757.69	\$814.72	\$946.49
WEMCO	318005-M-4003	Main Hoist Equalizer Weldment	\$2,594.07	\$3,456.76	\$3,679.53	\$4,397.91
WEMCO	318005-M-4048	Main Hoist Equalizer Weldment Pin	\$1,223.83	\$1,631.77	\$1,754.59	\$1,967.03
WEMCO	318005-A-4102L	Main Hoist Rope Guide (Left)	\$9,164.49	\$12,227.32	\$13,816.18	No Bid, Removed From Crane
WEMCO	318005-A-4102R	Main Hoist Rope Guide (Right)	\$9,164.49	\$12,227.32	\$13,816.18	No Bid, Removed From Crane
WEMCO	318005-M-4103	Main Hoist Rope Guide Weldment	\$183.27	\$244.36	\$285.61	No Bid, Removed From Crane
WEMCO	318005-M-4121	Main Hoist Rope Guide Flanged Hold-Down Roller	\$890.00	\$1,186.72	\$1,387.98	No Bid, Removed From Crane
WEMCO	318005-M-4126	Main Hoist Rope Guide Hold-Down Roller	\$418.00	\$557.33	\$651.85	No Bid, Removed From Crane
WEMCO	318005-M-4122	Main Hoist Rope Guide Seal Spacers	\$20.56	\$22.84	\$24.04	No Bid, Removed From Crane
WEMCO	318005-M-4123	Main Hoist Rope Guide Roller	\$614.00	\$818.66	\$957.50	No Bid, Removed From Crane
WEMCO	318005-M-4106	Main Hoist Rope Guide UHMW Wear Bar	\$182.96	\$215.25	\$240.50	No Bid, Removed From Crane
WEMCO	318005-M-4125	Main Hoist Rope Guide UHMW Wear Bar	\$289.20	\$348.47	\$389.35	No Bid, Removed From Crane
WEMCO	318005-M-4122	Main Hoist Rope Guide Seals	\$20.56	\$22.84	\$24.04	No Bid, Removed From Crane
WEMCO	318005-M-4116	ROUND TG&P, 1" OD X 5 3/4" LG STEEL AISI 4140	\$176.16	\$207.25	\$226.50	No Bid, Removed From Crane
WEMCO	318005-M-4115	ROUND TG&P, 1" OD X 7" LG STEEL AISI 4140	\$166.12	\$195.43	\$213.58	No Bid, Removed From Crane
WEMCO	318005-M-2015	End Tie Link Pins (Short)	\$534.33	\$628.62	\$675.94	\$757.78

WEMCO	318005-M-4035	Cable split bushing	\$171.85	\$214.82	\$237.37	\$250.39	\$259.47
WEMCO	318005-M-7301	Guide bar assembly (the one that got bent on the cable guide fiasco)	\$903.78	\$1,004.00	\$1,056.84	\$1,112.46	\$1,112.46
WEMCO	318005-M-4055	Sheave nest UHMW spacers	\$110.56	\$130.07	\$138.37	\$155.12	\$155.12
Timken	A6075	Main Hoist Rope Guide Bearings	\$22.72	\$32.70	\$49.89	\$68.46	No Bid, Removed From Crane
Timken	A6157	Main Hoist Rope Guide Bearings	\$12.38	\$17.81	\$27.17	\$31.84	No Bid, Removed From Crane
SKF	11289	Main Hoist Rope Guide Seals	\$5.27	\$7.47	\$8.77	\$12.06	No Bid, Removed From Crane
SKF	54925	Bridge Wheel Lip Seal 5.5" x 6.25" x 0.50"	\$38.44	\$59.23	\$89.52	\$95.82	\$67.90
SKF	29867	Bridge Wheel Axle Seal 3.0" x 3.75" x 0.375"	\$15.31	\$21.71	\$25.48	\$35.10	\$26.69
SKF	22216	Bridge Wheel Bearing 80mm x 140mm	\$247.41	\$295.39	\$416.92	\$478.75	\$422.66
SKF	47382	Trolley Wheel Seal, 4.75" x 5.751" x 0	\$60.25	\$86.41	\$100.25	\$115.13	\$104.99
SKF	23770	Trolley Drive Axle Seal, 2.375" x 3.50	\$14.91	\$21.14	\$24.82	\$34.20	\$25.99
SKF	22213	Trolley Wheel Bearing, 65mm x 120m	\$177.74	\$212.21	\$299.51	\$343.95	\$303.64
INA Shaeflter	SL045014-PP	Aux Hoist Lower Sheave Bearing, 70m	\$251.26	\$474.06	\$1,343.04	\$1,429.00	\$1,429.00
INA Shaeflter	SL045018-D-PP	Main Lower Sheave Bearing, 90mm x	\$434.98	\$759.93	\$2,335.04	\$2,473.85	\$2,473.85
General Bearing	31462-88	Aux Rope Guide Track, Flanged ball	\$5.24	\$6.84	\$17.34	\$17.04	\$16.04
Dodge	P4B-S2-407RE / 070383	Main Hoist Pillow Block, 4.4375"	\$1,997.75	\$2,691.96	\$3,240.94	\$3,687.97	\$3,015.91
Dodge	P4B-S1-207LE / 070419	Aux Hoist Pillow Block, 2.4375"	\$403.48	\$543.86	\$654.54	\$744.82	\$609.09
Duratrack	A2878-2	Festoon Trolley Wheel Bearings	No Bid	No Bid	No Bid	No Bid	No Bid
Duratrack	A-2335-1	Festoon Trolley Wheel	No Bid	No Bid	No Bid	No Bid	No Bid
Duratrack	BE6203-2	Festoon Tow Trolley Guide Wheel Bearing	No Bid	No Bid	No Bid	No Bid	No Bid
Duratrack	B2183-1	Festoon Tow Trolley Guide Wheel	No Bid	No Bid	No Bid	No Bid	No Bid
Duratrack	B2822-1	Festoon Main Wheel Assembly	\$25.41	\$33.88	\$45.23, Please Note, Duratrack now has a \$200 min. order	\$46.83 Please Note, Duratrack now has a \$200 min. order	\$50.91 Please Note, Duratrack now has a \$200 min. order
Duratrack	B2822-25	Festoon Anti-Lift Wheel Assembly	\$23.29	\$31.05	\$39.60 Please Note, Duratrack now has a \$200 min. order	\$42.90 Please Note, Duratrack now has a \$200 min. order	\$46.22 Please Note, Duratrack now has a \$200 min. order
Duratrack	A1101-1	Festoon Bumper Assembly	\$9.42	\$12.56	\$15.02 Please Note, Duratrack now has a \$200 min. order	\$17.35 Please Note, Duratrack now has a \$200 min. order	\$22.51 Please Note, Duratrack now has a \$200 min. order
Malmedie	TTXs 4	Main Hoist Gearbox to Drum Coupling	\$5,287.06	\$6,970.71	\$8,534.29	\$10,602.86	\$13,197.14
Malmedie	TTXs 1:3	Aux Hoist to Drum Coupling	\$3,176.47	\$4,248.21	\$5,638.46	\$6,542.86	\$7,297.14
Conductix-Wampfler	XA-11417X	Replacement Collector Shoe, 2 each per collector.	\$78.81	\$118.11	\$140.55	\$140.55	\$140.55
Gleason	GR03579105	Long Roller Assembly (Umbilical cable guide roller)	\$196.15	\$223.20	\$235.86	\$241.46	\$241.46
Gleason	GR015992	Complete roller guide assembly (Umbilical cable guide roller)	\$686.12	\$1,113.33	\$1,176.62	\$1,204.57	\$1,204.57
Osborn	97334	Aux Rope Guide Threaded V-Groove Track Roller	\$68.47	\$137.98	\$168.83	\$157.90	\$135.34
McMaster-Carr	2868T261	Main Hoist Equalizer Weldment Bushings	\$151.42	\$214.62	\$213.86	\$231.83	\$196.59
McMaster-Carr	6381K58	Main Hoist Equalizer Bar Bushing	\$23.75	\$35.33	\$35.71	\$62.64	\$65.78
McMaster-Carr	6391K684	End Tie Link Bushings	\$10.94	\$16.60	\$23.18	\$25.11	\$33.23, Replaced By 58365K132 on 9/11/2024
McMaster-Carr	6436K27	End Tie Link Lock Collars	\$19.43	\$27.53	\$39.66	\$42.97	\$39.94
Magnetek	111720	Mondel Brake Set	\$427.20	\$534.00	\$656.57	\$782.00	\$1,340.57
Magnetek	320420	Mondel 460V Brake Thruster	\$4,376.80	\$5,259.93	\$6,758.23	\$7,096.29	\$7,309.03
Magnetek	360481	Main Hoist Motor to Gearbox Coupling (Love Joy)	\$912.20	\$1,140.25	\$1,140.25	\$1,292.30	\$1,030.22
Sumitomo	PHD9065P3-LL-25	Main Hoist Gearbox Bearing and Seal Kit, Paramax 9065 Gearbox	\$4,646.28	\$5,468.56	\$6,433.60	\$7,172.35	\$13,311.47
Sumitomo	LHUXS-4B145L-Y1-39	Trolley Gearbox 988Z-PA247338 Bearing and seal kit	\$1,019.75	\$1,513.57	\$1,568.64	\$1,568.64	\$1,373.20

Sumitomo	988Z-PA247354	Rebuild Kit for BBB4 Cyclo Gearmotors	\$2,351.22	\$2,991.29	\$2,991.29	\$2,991.29	\$3,437.24
Sumitomo	988Z-PA247338	Rebuild Kit for BBB4 Cyclo Gearmotors	\$1,019.75	\$1,297.34	\$1,558.64	\$1,558.64	\$1,373.20
Crosby	1035036	Main Hoist Terminator Wedge Sockets	\$358.83	\$445.40	\$576.00	\$706.00	\$630.21
Sumitomo	LHJUS-4D195L-Y-35	988Z-PA247354 Bearing and seal kit	\$2,351.22	\$2,991.29	\$2,991.29	\$2,991.29	\$3,437.24
Sumitomo	AEPK4201-2	Toshiba Bridge Drive TENV Motor W/ brake	\$8,050.19	\$13,485.92	\$15,865.79	Discontinued by Toshiba. Replacement Sumitomo Part #GFC-LVM2-15, Replacement Price \$24,275.09	Discontinued by Toshiba. Replacement Sumitomo Part #GFC-LVM2-15, Replacement Price \$24,275.09
Wemco	3185005-W-4001	Main hoist drum	\$81,462.14	\$90,513.41	\$98,384.14	\$93,484.93	No Longer Used on Crane. Replaced By 14865-M-0001, Deep Groove Hoist Drum, \$88,491.62
Wemco	318005-M-4040	Rope Clamps	\$318.52	\$335.28	\$352.93	\$395.66	\$410.01
Magnatek	143-40395	AV551024 PPR encoder w/ epic connector	\$1,566.23	\$2,142.86	\$2,154.06	\$2,262.11	\$2,262.11
Magnatek	143-13183	175HP Bluemax Main hoist motor	\$31,158.46	\$35,294.45	\$57,193.05	\$60,330.22	\$54,250.00
Mondel	10269.0	Complete main hoist brake bearing and seal kit	\$25,450.00	\$22,016.92	\$14,758.14	\$12,922.27	\$12,922.27
Sumitomo	PHD9085P3-LL-25	Main hoist gear box to drum coupling	\$4,648.28	\$5,468.56	\$6,433.60	\$7,172.35	\$13,311.47
Wemco	3185005-W-4051	Main hoist gearbox key	\$161.30	\$189.76	\$208.51	\$233.76	\$242.23
Malmiede	318005-M-4010 or TTXs	Main hoist gear box to drum coupling	\$5,287.06	\$6,970.71	\$8,534.29	\$10,602.86	\$13,197.14
Avtron	AV65A1CMT8XP000	1024 PPR Encoder W/ Epic connector	\$2,329.42	\$2,911.74	\$2,654.84	\$2,906.88	\$2,553.00
Marathon	30 HP, 4P, TENV, 364T, Brake Provs	30 HP Aux hoist motor	\$5,882.36	\$12,682. discontinued by Marathon. Replaced by Magnetek Black Motor Line. New Part #MB03018-2286ke	\$12,682. discontinued by Marathon. Replaced by Magnetek Black Motor Line. New Part #MB03018-2286ke	\$15,718.77 Discontinued by Marathon. Replacement by Magnetek Black Motor Line. New Part # MB03018-2286ke	\$18,076.54 Discontinued by Marathon. Replacement by Magnetek Black Motor Line. New Part # MB03018-2286ke
Pintsch Bubenzer	81-000594710214	SFB 16, brake disk hub, motor side, 38mm	\$607.22	\$607.22	\$970.29	\$1,028.58	\$1,082.72
Pintsch Bubenzer	81-000594710214	SFB 16, brake disk hub, gear box side, 42mm	\$607.22	\$731.59	\$970.29	\$1,028.58	\$1,082.72
Pintsch Bubenzer	81-VALL, SFB 16 coil/body	SFB 16, 460V Brake coil	\$1,318.19	\$731.59	\$2,187.09	\$2,399.74	\$2,423.41
Pintsch Bubenzer	81-VALL, SFB 15 W/Hub	Complete aux hoist brake	\$2,016.68	\$1,588.18	\$3,253.21	\$3,797.54	\$3,468.10
Malmiede	3185005-M7208 or TTXs 1.3	Aux hoist to drum coupling	\$3,176.47	\$4,248.21	\$5,638.46	\$6,542.86	\$7,297.14
Sumitomo	AEPK4201-1	Toshiba trolley drive TENV Motor W/ brake	\$5,714.01	\$8,882.72	\$10,450.26	Discontinued by Toshiba. Replacement Sumitomo Part#GFC-LVM2-7.5, \$17,231.03	Discontinued by Toshiba. Replacement Sumitomo Part#GFC-LVM2-7.5, \$17,231.03
General	31462-88	Flanged ball bearing .375" x .8750" x .3438"	\$5.24	\$6.84	\$17.34	\$18.77	\$18.77
Percentage Off List for any other crane related associated Mechanical Spare Parts not listed on "RFQ 5338-20 Pricing Page", but may be realized are needed at a later point in time. Enter Percentage Off List			5%	5%	5%	5%	5%
Percentage Markup Above Vendor's Cost, should Vendor not provide percentage off list, for any other crane related associated Mechanical Spare Parts not listed on "RFQ 5338-20 Pricing Page", but may be realized are needed at a later point in time. Enter Percentage Markup Above Vendor's Cost			15%	15%	15%	15%	15%
Base Year Pricing Per WEMCO's response to RFQ 5165-19							Matt Humphrey
							Signature <i>Matthew J Humphrey</i>
							Date \$45,553.00



< Business Lookup

### License Information:

[New search](#) [Back to results](#)

**Entity name:** WASHINGTON EQUIPMENT MANUFACTURING COMPANY, INC.

**Business name:** WASHINGTON EQUIPMENT MANUFACTURING COMPANY, INC.

**Entity type:** [Profit Corporation](#)

**UBI #:** 601-174-038

**Business ID:** 001

**Location ID:** 0001

**Location:** Active

**Location address:** 5510 W THORPE RD  
SPOKANE WA 99224-5371

**Mailing address:** 5510 W THORPE RD  
SPOKANE WA 99224-5371

**Excise tax and reseller permit status:** [Click here](#)

**Secretary of State status:** [Click here](#)

### Endorsements

Endorsements held at this location	License #	Count	Details	Status	Expiration date	First issuance date
<a href="#">Minor Work Permit</a>				Active	Apr-30-2025	Feb-24-2020
<a href="#">Moses Lake General Business - Non-Resident</a>	BUS2020-0349			Active	Apr-30-2025	May-18-2020
<a href="#">Spokane General Business - Non-Resident</a>	T12003901BUS			Active	Apr-30-2025	Oct-15-2012

### Governing People May include governing people not registered with Secretary of State

Governing people	Title
ROUSE, JOHN	
ROUSE, JUSTON	
ROUSE, KARMA	
TURNER, MATTHEW	

### Registered Trade Names

Registered trade names	Status	First issued
WEMCO INC	Active	May-02-1989

The Business Lookup information is updated nightly. Search date and time: 10/2/2024 1:59:11 PM

[Contact us](#)

How are we doing?  
[Take our survey!](#)

Don't see what you expected?  
[Check if your browser is supported](#)





CERTIFICATE OF LIABILITY INSURANCE

DATE (MM/DD/YYYY)
4/30/2024

THIS CERTIFICATE IS ISSUED AS A MATTER OF INFORMATION ONLY AND CONFERS NO RIGHTS UPON THE CERTIFICATE HOLDER. THIS CERTIFICATE DOES NOT AFFIRMATIVELY OR NEGATIVELY AMEND, EXTEND OR ALTER THE COVERAGE AFFORDED BY THE POLICIES BELOW.

IMPORTANT: If the certificate holder is an ADDITIONAL INSURED, the policy(ies) must have ADDITIONAL INSURED provisions or be endorsed. If SUBROGATION IS WAIVED, subject to the terms and conditions of the policy, certain policies may require an endorsement.

Table with PRODUCER and INSURED information. PRODUCER: Hub International Northwest LLC, Spokane, WA 99220. INSURED: WEMCO, Inc., 5510 W Thorpe Road, Spokane, WA 99224. CONTACT NAME: Stacia Simpson, PHONE: (509) 319-2912, FAX: (A/C, No):, E-MAIL ADDRESS: Stacia.Simpson@hubinternational.com. INSURER(S) AFFORDING COVERAGE: Berkley Specialty Insurance Company (31295), Alaska National Insurance Company (38733), Navigators Specialty Insurance Company (36056).

COVERAGES CERTIFICATE NUMBER: REVISION NUMBER:

THIS IS TO CERTIFY THAT THE POLICIES OF INSURANCE LISTED BELOW HAVE BEEN ISSUED TO THE INSURED NAMED ABOVE FOR THE POLICY PERIOD INDICATED. NOTWITHSTANDING ANY REQUIREMENT, TERM OR CONDITION OF ANY CONTRACT OR OTHER DOCUMENT WITH RESPECT TO WHICH THIS CERTIFICATE MAY BE ISSUED OR MAY PERTAIN, THE INSURANCE AFFORDED BY THE POLICIES DESCRIBED HEREIN IS SUBJECT TO ALL THE TERMS, EXCLUSIONS AND CONDITIONS OF SUCH POLICIES. LIMITS SHOWN MAY HAVE BEEN REDUCED BY PAID CLAIMS.

Main coverage table with columns: INSR LTR, TYPE OF INSURANCE, ADDL INSD, SUBR WVD, POLICY NUMBER, POLICY EFF (MM/DD/YYYY), POLICY EXP (MM/DD/YYYY), LIMITS. Includes Commercial General Liability, Automobile Liability, Umbrella Liability, Workers Compensation, and Installation Floater.

DESCRIPTION OF OPERATIONS / LOCATIONS / VEHICLES (ACORD 101, Additional Remarks Schedule, may be attached if more space is required) PROJECT: PW ITB 5101-19 REFUSE CRANES QUARTERLY PREVENTIVE MAINTENANCE INSPECTIONS AND UNSCHEDULED SERVICES FOR TWO 9-TON, TOP RUNNING DOUBLE GRINDER (TRDG) BRIDGE CRANES

THE CITY OF SPOKANE, ITS OFFICERS AND EMPLOYEES ARE ADDITIONAL INSURED AS RESPECTS TO THE GENERAL & AUTO LIABILITY & WAIVER OF SUBROGATION IS GRANTED AS IT RELATES TO THE GENERAL & AUTO LIABILITY WITH THE TERMS AND CONDITIONS OF THE POLICIES. UMBRELLA FOLLOWS FORMS. THE COVERAGE IS PRIMARY AND NON-CONTRIBUTORY WHERE REQUIRED BY A WRITTEN CONTRACT.

CERTIFICATE HOLDER: CITY OF SPOKANE, 2900 S GEIGER BLVD., ATTN: MICHELLE DORGAN, SPOKANE, WA 99224. CANCELLATION: SHOULD ANY OF THE ABOVE DESCRIBED POLICIES BE CANCELLED BEFORE THE EXPIRATION DATE THEREOF, NOTICE WILL BE DELIVERED IN ACCORDANCE WITH THE POLICY PROVISIONS. AUTHORIZED REPRESENTATIVE: [Signature]



# WAIVER OF TRANSFER OF RIGHTS OF RECOVERY AGAINST OTHERS TO US

This endorsement modifies insurance provided under the following:

COMMERCIAL GENERAL LIABILITY COVERAGE PART  
PRODUCTS/COMPLETED OPERATIONS LIABILITY COVERAGE PART

## SCHEDULE

**Name Of Person Or Organization:**

All Persons or Organizations when such Waiver is required by written contract with you and executed prior to the occurrence of the injury or damage for which we make payments on your behalf.

Information required to complete this Schedule, if not shown above, will be shown in the Declarations.

The following is added to Paragraph 8. **Transfer Of Rights Of Recovery Against Others To Us** of Section IV – Conditions:

We waive any right of recovery we may have against the person or organization shown in the Schedule above because of payments we make for injury or damage arising out of your ongoing operations or "your work" done under a contract with that person or organization and included in the "products-completed operations hazard". This waiver applies only to the person or organization shown in the Schedule above.

THIS ENDORSEMENT CHANGES THE POLICY. PLEASE READ IT CAREFULLY.

**ADDITIONAL INSURED - PRIMARY AND NONCONTRIBUTORY -  
AUTOMATIC STATUS WHEN REQUIRED IN A WRITTEN CONTRACT OR  
AGREEMENT  
(Including Completed Operations)**

This endorsement modifies insurance provided under the following:

COMMERCIAL GENERAL LIABILITY COVERAGE PART

**SCHEDULE**

**Date:** 5/1/2023

**A. Section II - Who Is An Insured is amended** to include as an additional insured any person or organization for whom you are performing operations when you and such person or organization have agreed in writing in a contract or agreement that such person or organization be added as an additional insured on your policy. Such person or organization is an additional insured only with respect to liability for "bodily injury", "property damage" or "personal and advertising injury" caused, in whole or in part, by:

1. Your acts or omissions, or the acts or omissions of those acting on your behalf in the performance of your ongoing operations for the additional insured; or
2. "Your work" and included in the "products-completed operations hazard".

but only for "occurrences" or coverages not otherwise excluded in the Coverage Part to which this endorsement applies.

However the insurance afforded to such additional insured:

1. Only applies to the extent permitted by law; and
2. Will not be broader than that which you are required by the contract or agreement to provide for such additional insured.

**B.** Status as an additional insured for the person or organization to which this endorsement applies commences during the policy period and after such written contract or agreement has been executed.

**C.** With respect to the insurance afforded to the additional insured, the following additional exclusions apply:

This insurance does not apply to:

1. "Bodily injury", "property damage", "personal and advertising injury" or medical payments arising out of the rendering of, or the failure to render, any professional architectural, engineering or surveying services, including:
  - a. The preparing, approving, or failure to prepare or approve, maps, shop drawings, opinions, reports, surveys, field orders, change orders or drawings and specifications; or
  - b. Supervisory, inspection, architectural or engineering activities.

This exclusion applies even if the claims against any insured allege negligence or other wrongdoing in the supervision, hiring, employment, training or monitoring of others by that insured, if the "occurrence" which caused the "bodily injury" or "property damage", or the offense which caused the "personal and advertising injury", involved the rendering of or the failure to render any professional architectural, engineering, or surveying services.

2. "Bodily injury" or "property damage" included in the "products-completed operations hazard" and arising out of "your work" that was completed by or on behalf of any insured prior to the date shown in the Schedule of this endorsement.

**D. With respect to the insurance afforded to the additional insured, the following is added to **Section III – Limits Of Insurance:****

The most we will pay on behalf of the additional insured is the amount of insurance:

1. Required by the contract or agreement you have entered into with the additional insured; or
2. Available under the applicable limits of insurance;

whichever is less.

This endorsement shall not increase the applicable limits of insurance.

**E. The following condition is added to 4.a. of **Other Insurance** of **Section IV - Commercial General Liability Conditions:****

If required in a written contract, the Coverage Part to which this endorsement applies is primary and noncontributory in the event of an "occurrence" caused, in whole or in part, by your acts or omissions, or the acts or omissions of those acting on your behalf that:

1. Occurs while performing ongoing operations for the additional insured, or
2. Is included in the "products-completed operations hazard" and arises out of "your work" that was completed by or on behalf of any insured after the date shown in the Schedule of this endorsement.

All other terms and conditions remain unchanged.

**THIS ENDORSEMENT CHANGES THE POLICY. PLEASE READ IT CAREFULLY.**

**AMENDMENT OF CONDITIONS  
OTHER INSURANCE  
PRIMARY AND NON-CONTRIBUTING**

This endorsement modifies insurance provided under the following:

COMMERCIAL EXCESS LIABILITY COVERAGE PART

SCHEDULE

When required by written contract executed before the "loss."

- A. Section IV - Conditions, 9. Other Insurance is deleted and replaced by the following:
  - 9. This insurance is excess over any other insurance available to the insured except:
    - a. insurance that is purchased specifically to apply in excess of this policy; or
    - b. insurance available to the person or organization shown in the Schedule of this endorsement as an additional insured on the "controlling underlying insurance."
- B. When this insurance applies on a primary and non-contributing basis, the Limits of Insurance available for the additional insured will be the lesser of:
  - 1. the amounts shown in item 3 of the Declarations of this policy; or
  - 2. the amount of insurance you are required to provide the additional insured in the written contract or agreement.

All other terms of the policy remain unchanged.

**SECTION II – WHO IS AN INSURED**

The WHO IS AN INSURED section of the “controlling underlying insurance” is made part of this policy. Any person or organization that is an insured in “controlling underlying insurance” is an insured in this policy to the same extent.

**SECTION III – LIMITS OF INSURANCE**

The Limits of Insurance shown in the Declarations and the rules below fix the most we will pay regardless of the number of insureds, claims made or suits brought, or persons or organizations making claims or bringing suits.

1. The General Aggregate Limit is the most we will pay for the sum of all damages to which this insurance applies, except:
  - a. damages because of bodily injury or property damage included within any applicable products-completed operations hazard; or
  - b. damages arising out of the ownership, operation, maintenance or use of an automobile;
2. The Products-Completed Operations Aggregate Limit is the most we will pay for the sum of all damages included within any applicable products-completed operations hazard;
3. Subject to paragraphs 1. and 2. above, the Each Event Limit is the most we will pay for all damages that arise out of any one “event.”

**SECTION IV – CONDITIONS**

The CONDITIONS sections of the “controlling underlying insurance” are made part of this policy. If an inconsistency or contradiction exists between the Conditions of this policy and the Conditions of the “controlling underlying insurance,” the Conditions of this policy will apply.

1. Appeals  
At our discretion we may appeal any judgment which would result in a payment under this policy. When we do appeal, we will pay all costs associated with the appeal in addition to the Limits of Insurance. Any such appeal will not increase our Limits of Insurance.
2. Bankruptcy or Insolvency  
Bankruptcy or insolvency of the insured or the insured's estate will not relieve us of our obligations under this policy. Bankruptcy or insolvency of any company providing “controlling underlying insurance” will not reduce the “underlying limits” or increase our obligations under this policy. We will not be required to drop down or replace “controlling underlying insurance.”
3. Cancellation
  - a. The first Named Insured may cancel this policy at any time by providing us advanced written notice of the cancellation date.
  - b. We may cancel this policy at any time by providing the first Named Insured written notice of cancellation:
    - i. at least 10 days in advance if we cancel for non-payment of premium; or
    - ii. at least 30 days in advance if we cancel for any other reason:

- d. No insured will, except at that insured's own cost, voluntarily make a payment, assume any obligation or incur any expense, other than first aid, without our consent. Notice to us may be sent to our address shown in the Declarations.
7. **Legal Action Against Us**  
No person or organization has a right under this insurance:
- to join us as a party or otherwise bring us into a suit asking for damages from an insured; or
  - to sue us on this insurance unless all of its terms have been fully complied with.
8. **Maintenance of Controlling Underlying Insurance**  
During the "policy period" you must maintain "controlling underlying insurance" with "underlying limits" at least equal to the amounts shown in the Declarations. The "underlying limits" must be unimpaired at the beginning of this "policy period." If you fail to maintain the "controlling underlying insurance" this policy will be invalid. If you fail to maintain "underlying limits," we will only be liable to the extent we would have been liable had you maintained the "underlying limits." Reduction of "underlying limits" by the payment of judgments or settlements for "loss" to which this insurance applies, or would have applied but for the amount of the damages, will not be considered a failure to maintain "underlying limits."
9. **Other Insurance**  
This insurance is excess over any insurance available to the insured except insurance purchased specifically to apply in excess of this policy.
10. **Payment of Damages**  
When the amount of damages payable under this policy has been determined by final judgment or a written settlement agreement between the claimant and us, we will pay that amount, up to our applicable Limits of Insurance, after the "controlling underlying insurance" or the insured has paid the full amount of the "underlying limits."
11. **Premium**  
The Premium shown in the Declarations is the premium for the coverage we provide for the "policy period." The first Named Insured is responsible for the payment of all premiums under this policy. If this policy is cancelled prior to its expiration date return premium will be calculated as follows:
- if cancelled by us:  
$$\{[(\text{Premium}) - (\text{Minimum Earned Premium})] \times (\text{Pro Rata factor})\}$$
  - if cancelled by you:  
$$\{[(\text{Premium}) - (\text{Minimum Earned Premium})] \times \{(\text{Pro Rata factor}) \times (.90)\}\}$$
12. **Separation of Insureds**  
Except with respect to the Limits of Insurance and any rights or duties specifically assigned in this policy to the first Named Insured, this insurance applies:
- as if each Named Insured were the only Named Insured; and
  - separately to each insured against whom claim is made or suit is brought.
13. **Transfer of Rights of Recovery Against Others**  
If an insured has rights to recover all or part of any payment we have made under this insurance, the insured must preserve those rights and, at our request, pursue or transfer those rights to us. The insured must do nothing after an "event" to impair them.

**THIS ENDORSEMENT CHANGES THE POLICY. PLEASE READ IT CAREFULLY.**

**CONSTRUCTION PROJECT GENERAL AGGREGATE LIMIT WHEN  
REQUIRED BY CONTRACT AND  
MAXIMUM PER POLICY GENERAL AGGREGATE LIMIT**

This Endorsement modifies insurance provided under the following:

**COMMERCIAL GENERAL LIABILITY COVERAGE PART**

**SCHEDULE**

**Limits of Insurance**

Maximum Per Policy General Aggregate Limit \$5,000,000

- A. For all sums which the insured becomes legally obligated to pay as damages caused by "occurrences" under **Section I - Coverage A - Bodily Injury And Property Damage Liability**, and for all medical expenses caused by accidents under **Section I - Coverage C - Medical Payments**, which can be attributed only to ongoing operations at a single construction project:
1. A separate Construction Project General Aggregate Limit applies to each construction project when required in a written construction contract or agreement, and that limit is equal to the amount of the General Aggregate Limit shown in the Declarations.
  2. The Construction Project General Aggregate Limit is the most we will pay for the sum of all damages under **Coverage A**, except damages because of "bodily injury" or "property damage" included in the "products-completed operations hazard", and for medical expenses under **Coverage C** regardless of the number of:
    - a. Insureds;
    - b. Claims made or "suits" brought; or
    - c. Persons or organizations making claims or bringing "suits".
  3. Any payments made under **Coverage A** for damages or under **Coverage C** for medical expenses shall reduce the Construction Project General Aggregate Limit for that construction project. Such payments shall not reduce the General Aggregate Limit shown in the Declarations nor shall they reduce any other Construction Project General Aggregate Limit for any other construction project.
  4. The limits shown in the Declarations for Each Occurrence, Damage To Premises Rented To You and Medical Expense continue to apply. However, instead of being subject to the General Aggregate Limit shown in the Declarations, such limits will be subject to the applicable Construction Project General Aggregate Limit.
  5. The Maximum Per Policy General Aggregate Limit shown in the Schedule is the most we will pay for the sum of all Construction Project General Aggregate Limits and the General Aggregate Limit shown in the Declarations regardless of the number of:
    - a. Insureds;
    - b. Claims made or "suits" brought;
    - c. Persons or organizations making claims or bringing "suits"; or
    - d. Construction projects.

- B. For all sums which the insured becomes legally obligated to pay as damages caused by "occurrences" under **Section I - Coverage A - Bodily Injury And Property Damage Liability**, and for all medical expenses caused by accidents under **Section I - Coverage C - Medical Payments**, which cannot be attributed only to ongoing operations at a single construction project:
  - 1. Any payments made under **Coverage A** for damages or under **Coverage C** for medical expenses shall reduce the amount available under the General Aggregate Limit shown in the Declarations or the Products-Completed Operations Aggregate Limit shown in the Declarations, whichever is applicable; and
  - 2. Such payments shall not reduce any Construction Project General Aggregate Limit.
- C. When coverage for liability arising out of the "products-completed operations hazard" is provided, any payments for damages because of "bodily injury" or "property damage" included in the "products-completed operations hazard" will reduce the Products-Completed Operations Aggregate Limit shown in the Declarations, and not reduce the General Aggregate Limit shown in the Declarations nor the Construction Project General Aggregate Limit.
- D. If the applicable construction project has been abandoned, delayed, or abandoned and then restarted, or if the authorized contracting parties deviate from plans, blueprints, designs, specifications, or timetables, the project will still be deemed to be the same construction project.
- E. The provisions of **Section III - Limits Of Insurance** not otherwise modified by this endorsement shall continue to apply as stipulated.

All other terms and conditions of this policy remain unchanged.



**THIS ENDORSEMENT CHANGES THE POLICY. PLEASE READ IT CAREFULLY.**

## **WAIVER OF SUBROGATION**

### **SCHEDULE**

**Name of Person or Organization:**

As required by written contract or agreement.

Information required to complete this Schedule, if not shown above, will be shown in the Declarations.

The following is added to SECTION IV - CONDITIONS, 13. Transfer of Rights of Recovery Against Others.

We waive any right of recovery we may have against the person or organization shown in the Schedule above because of payments we make for injury or damage arising out of your ongoing operations or "your work" done under a contract with that person or organization. This waiver applies only to the person or organization shown in the Schedule above.

All other terms of the policy remain unchanged.

---

**WAIVER OF OUR RIGHT TO RECOVER FROM OTHERS ENDORSEMENT**

---

We have the right to recover our payments from anyone liable for an injury covered by this policy. We will not enforce our right against the person or organization named in the Schedule. (This agreement applies only to the extent that you perform work under

a written contract that requires you to obtain this agreement from us.)

This agreement shall not operate directly or indirectly to benefit any one not named in the Schedule.

**SCHEDULE**

Any person or organization for whom the Insured has agreed by written contract to furnish this waiver.

This endorsement changes the policy to which it is attached and, unless otherwise stated, is effective on the date issued at 12:01 A.M. standard time at your mailing address shown in the policy. **The information below is required only when this endorsement is issued subsequent to commencement of the policy.**

Endorsement Effective 5/1/2024

Policy No. 24HWS08952

Insured WEMCO, Inc.

Endorsement No. 5

Countersigned By \_\_\_\_\_



---

**BUSINESS AUTO COVERAGE ENHANCEMENT ENDORSEMENT**

---

**THIS ENDORSEMENT CHANGES THE POLICY. PLEASE READ IT CAREFULLY.**

This endorsement modifies insurance provided under the following:

**BUSINESS AUTO COVERAGE FORM**

Various provisions in this endorsement restrict coverage. Read the entire policy carefully to determine rights, duties, and what is and is not covered.

Throughout this policy, the words "you" and "your" refer to the Named Insured shown in the Declarations. The words "we", "us", and "our" refer to the company providing this insurance.

Other words and phrases that appear in quotation marks have special meaning. Refer to **SECTION V – DEFINITIONS** in the Business Auto Coverage Form.

The coverages provided by this endorsement apply per "accident" and, unless otherwise specified, are subject to all of the terms, conditions, exclusions and deductible provisions of the policy, to which it is attached.

**SECTION II – COVERED AUTO LIABILITY COVERAGE**, Paragraph A.1. Who Is An Insured is amended to include:

- d. Any "employee" of yours while operating an "auto" hired or rented under a contract or agreement in an "employee's" name, with your permission, while performing duties related to the conduct of your business.
- e. Any person or organization for whom you have agreed in writing to provide insurance such as is afforded by this Coverage Form, but only with respect to liability arising out of the ownership, maintenance or use of "autos" covered by this policy. If such person or organization has other insurance then this insurance is primary to and we will not seek contribution from the other insurance.

**SECTION IV – Business Auto Conditions, Paragraph A. 5. – Transfer of Rights of Recovery Against Others To Us** is amended to include:

**5. Transfer of Rights of Recovery Against Others to Us**

This condition does not apply to any person(s) or organization(s) to the extent that subrogation against that person or organization is waived prior to the "accident" or the "loss" under a contract with that person or organization.

**SECTION II – COVERED AUTO LIABILITY COVERAGE**, Paragraph A.2.a. (2) – **Supplementary Payments** is replaced by the following:

- (2) Up to \$10,000 for cost of bail bonds (including bonds for related traffic law violations) required because of an "accident" we cover. We do not have to furnish these bonds.

**SECTION II – COVERED AUTO LIABILITY COVERAGE**, Paragraph A.2.a. (4) – **Supplementary Payments** is replaced by the following:

- (4) All reasonable expenses incurred by the "insured" at our request, including actual loss of earnings up to \$500 a day because of time off from work.

**SECTION II – COVERED AUTO LIABILITY COVERAGE**, Paragraph A.2.c. – **Voluntary Property Damage** is added as follows:

**c. Voluntary Property Damage**

At your written request, we may make a voluntary payment for Property Damage caused by an “insured”, but without liability to a third party, up to \$25,000. We will not make a Voluntary Property Damage payment to anyone who is an “insured” under this policy.

**SECTION III – PHYSICAL DAMAGE COVERAGE**, Paragraph A.2. – **Towing** is replaced by the following:

**Towing**

We will pay up to \$500 for towing and labor costs incurred each time a covered “auto” that is a:

- a. Private passenger;
- b. Truck;
- c. Pick-up truck;
- d. Panel ; or
- e. Van

type vehicle under 20,000 lbs. of Gross Vehicle Weight is disabled. However, the labor must be performed at place of disablement.

**SECTION III – PHYSICAL DAMAGE COVERAGE**, Paragraph A.3. – **Glass Breakage – Hitting a Bird or Animal – Falling Objects or Missiles** is replaced by the following:

**Glass Breakage – Hitting a Bird or Animal – Falling Objects or Missiles**

If you carry Comprehensive Coverage for the damaged covered “auto”, we will pay the following under Comprehensive Coverage:

- a. Glass Breakage;
- b. “Loss” caused by hitting a bird or animal; and

- c. “Loss” caused by falling objects or missiles.

However, you have the option of having glass breakage caused by a covered “auto’s” collision or overturn considered a “loss” under Collision Coverage.

**Glass Repair – Waiver of Deductible**

No deductible applies to glass breakage, if the glass is repaired rather than replaced.

**SECTION III – PHYSICAL DAMAGE COVERAGE**, Paragraph A.4.a. – **Transportation Expenses** is replaced by the following:

**a. Transportation Expenses**

We will pay up to \$200 per day to a maximum of \$1,500 for temporary transportation expense incurred by you because of the total theft of a covered “auto” that is a:

- (1) Private passenger;
- (2) Truck;
- (3) Pick-up truck;
- (4) Panel; or
- (5) Van

type vehicle under 20,000 lbs. of Gross Vehicle Weight. We will pay only for those covered “autos” for which you carry either Comprehensive or Specified Causes of Loss Coverage. We will pay for temporary transportation expenses incurred during the period beginning 48 hours after the theft and ending, regardless of the policy’s expiration, when the covered “auto” is returned to use or we pay for its “loss”.

**SECTION III – PHYSICAL DAMAGE COVERAGE,**  
Paragraph A.4.b. – **Loss of Use Expenses** is  
replaced by the following:

**b. Loss of Use Expenses – Hired, Rented,  
or Borrowed Automobiles**

We will pay expenses for which an  
“insured” becomes legally responsible to  
pay for loss of use of a vehicle hired,  
rented or borrowed without a driver under  
a written rental contract or agreement.  
We will pay for loss of use expenses, if  
caused by:

- (1) Other than Collision, only if the  
Declarations indicate that  
Comprehensive Coverage is provided  
for the vehicle withdrawn from  
service.
- (2) Specified Causes of Loss only if the  
Declarations indicate that Specified  
Causes of Loss Coverage is provided  
for the vehicle withdrawn from  
service.
- (3) Collision only if the Declarations  
indicate that Collision Coverage is  
provided for the vehicle withdrawn  
from service.

However, the most we will pay for any  
expenses for loss of use is \$200 per day, to a  
maximum of \$1,500.

**SECTION III – PHYSICAL DAMAGE COVERAGE,**  
Paragraph A.4.c. – **Non-Transportation Loss of Use  
Expenses** is added as follows:

**c. Non-Transportation Loss of Use  
Expenses**

We will pay up to \$2,000 for non-  
transportation expense incurred by you,  
because of “loss” to a covered “auto”, if  
caused by:

- (1) Other than Collision, only if the  
Declarations indicate that  
Comprehensive Coverage is provided  
for the “auto” withdrawn from service;

- (2) Specified Causes of Loss only if the  
Declarations indicate that Specified  
Causes of Loss Coverage is provided  
for the “auto” withdrawn from service;  
or
- (3) Collision only if the Declarations  
indicate that Collision Coverage is  
provided for the “auto” withdrawn  
from service.

**SECTION III – PHYSICAL DAMAGE COVERAGE,**  
Paragraph A.4.d. – **Airbag Coverage** is added as  
follows:

**d. Airbag Coverage**

We will pay for the cost to repair, replace,  
or reset an airbag that inflates for any  
reason other than as a result of a  
collision, if the Declarations indicate that  
the covered “auto” has Comprehensive  
Coverage or Specified Causes of Loss  
Coverage.

**SECTION III – PHYSICAL DAMAGE COVERAGE,**  
Paragraph A.4.e. – **Rental Reimbursement  
Coverage** is added as follows:

**e. Rental Reimbursement Coverage**

We will pay up to \$75 per day for rental  
reimbursement expenses incurred by you  
for the rental of an “auto” because of  
“loss” to a covered “auto” that is a:

- (1) Private Passenger;
- (2) Truck;
- (3) Pick-up truck;
- (4) Panel; or
- (5) Van

type vehicle under 20,000 lbs. of Gross  
Vehicle Weight. Payment applies in  
addition to the otherwise applicable  
amount of each coverage you have on a  
covered “auto”. No deductibles apply to  
this coverage.

- (1) We will pay only for those expenses incurred during the policy period beginning 24 hours after the "loss" and ending, regardless of the policy's expiration, with the lesser of the following number of days:
  - (a) The number of days reasonably required to repair or replace the covered "auto".
  - (b) 30 days.
- (2) This coverage does not apply while there are spare or reserve "autos" available to you for your operations.
- (3) The Rental Reimbursement Coverage described above does not apply to a covered "auto" that is described or designated as a covered "auto" on Rental Reimbursement Coverage Form CA 99 23.

**SECTION IV – BUSINESS AUTO CONDITIONS –** Paragraph B.2. – Concealment, Misrepresentation Or Fraud is amended by adding **Unintentional Failure to Disclose Hazards** at the end of Paragraph B.2. as follows:

**Unintentional Failure to Disclose Hazards**

If you unintentionally fail to disclose any hazards existing at the inception date of your policy, we will not deny coverage under this Coverage Form because of such failure. However, this provision does not affect our right to collect additional premium or exercise our right of cancellation or non-renewal.

**SECTION IV – BUSINESS AUTO CONDITIONS –** Paragraph B.5.b. – **Other Insurance** is replaced by the following:

- b. For Hired Auto Physical Damage Coverage, the following are deemed to be covered "autos" you own:
  - (1) Any covered "auto" you lease, hire, rent, or borrow; and
  - (2) Any covered "auto" hired or rented by your "employee" under a contract in that individual "employee's" name, with your permission, while performing duties related to the conduct of your business.

However, any "auto" that is leased, hired, rented or borrowed with a driver is not a covered "auto".

**SECTION V – DEFINITIONS –** Paragraph C. – **"Bodily injury"** is replaced by the following:

- C. "Bodily injury" means bodily injury, sickness or disease sustained by a person including death or mental anguish resulting from any of these. Mental anguish means any type of mental or emotional illness or disease

This endorsement changes the policy to which it is attached and, unless otherwise stated, is effective on the date issued at 12:01 A.M. standard time at your mailing address shown in the policy. **The information below is required only when this endorsement is issued subsequent to commencement of the policy.**

Endorsement Effective 5/1/2017

Policy No. 17EPS08952

Insured WEMCO, Inc.

Endorsement No. 3

Countersigned By \_\_\_\_\_

**Agenda Sheet for City Council:****Committee:** PIES **Date:** 10/21/2024**Committee Agenda type:** Consent**Date Rec'd**

10/22/2024

**Clerk's File #**

OPR 2021-0716

**Cross Ref #****Project #****Council Meeting Date:** 11/04/2024**Submitting Dept**

SOLID WASTE DISPOSAL

**Bid #**

PW ITB 5506-21

**Contact Name/Phone**

DAVID PAINE 625-6878

**Requisition #**

CR 26788

**Contact E-Mail**

DPAINE@SPOKANECITY.ORG

**Agenda Item Type**

Contract Item

**Council Sponsor(s)**

BWILKERSON JBINGLE KKLITZKE

**Agenda Item Name**

4490-CONTRACT RENEWAL FOR MECHANICAL REPAIRS AT THE WASTE TO

**Agenda Wording**

Contract renewal 3 of 4 with Knight Const. & Supply, Inc. (Deer Park, WA) for mechanical repairs at the Waste to Energy Facility from 11/1/2024-10/31/2025 and a total cost not to exceed \$2,200,000.00 plus tax.

**Summary (Background)**

The necessary scheduled and emergency maintenance work at the Waste to Energy Facility requires specialized millwright skills. On Sept. 20, 2021, bidding closed on PW ITB 5506-21 for these services and Knight Const. & Supply, Inc. was the only respondent. The initial contract award was for one year with the possibility of four (4) additional one-year renewals. This will be the third renewal and pricing has been increased to reflect current prevailing wage rates.

Lease? NO Grant related? NO Public Works? YES

**Fiscal Impact**

Approved in Current Year Budget? YES

Total Cost \$ 2,200,000.00

Current Year Cost \$

Subsequent Year(s) Cost \$

**Narrative**

This is a routine repair and maintenance expense that was planned for in the Solid Waste Disposal budget.

**Amount****Budget Account**

Expense \$ 2,200,000.00

# 4490-44100-37148-54803-34002

Select \$

#

Select \$

#

Select \$

#

\$

#

\$

#



**Continuation of Wording, Summary, Approvals, and Distribution**

**Agenda Wording**

**Summary (Background)**

**Approvals**

<b><u>Dept Head</u></b>	AVERYT, CHRIS
<b><u>Division Director</u></b>	FEIST, MARLENE
<b><u>Accounting Manager</u></b>	ALBIN-MOORE, ANGELA
<b><u>Legal</u></b>	SCHOEDEL, ELIZABETH
<b><u>For the Mayor</u></b>	PICCOLO, MIKE

**Additional Approvals**

<b><u>PURCHASING</u></b>	PRINCE, THEA

**Distribution List**

Dave Knight, dave@knightconst.com	mdorgan@spokanecity.org
jsalstrom@spokanecity.org	tprince@spokanecity.org
rrinderle@spokanecity.org	



## Committee Agenda Sheet

### Public Infrastructure, Environment & Sustainability Committee

<b>Committee Date</b>	October 21, 2024
<b>Submitting Department</b>	Solid Waste Disposal
<b>Contact Name</b>	David Paine
<b>Contact Email &amp; Phone</b>	<a href="mailto:dpaine@spokanecity.org">dpaine@spokanecity.org</a> , 509-625-6878
<b>Council Sponsor(s)</b>	Wilkerson, Bingle, Klitzke
<b>Select Agenda Item Type</b>	<input checked="" type="checkbox"/> Consent <input type="checkbox"/> Discussion    Time Requested:
<b>Agenda Item Name</b>	Contract renewal for mechanical repairs at the Waste to Energy Facility
<b>Proposed Council Action</b>	<input checked="" type="checkbox"/> Approval to proceed to Legislative Agenda <input type="checkbox"/> Information Only
<b>Summary (Background)</b>  *use the Fiscal Impact box below for relevant financial information	<p>Necessary scheduled and emergency maintenance work at the Waste to Energy Facility requires specialized millwright skills. Contractors must be qualified to perform grate module inspections, replacements and repairs on Von Roll Type R-10046 grates and a Combustion Engineering Continuous Ash Discharge Spreader Stoker in accordance with manufacturers' specifications.</p> <p>On Sept. 20, 2021, bidding closed on PW ITB #5506-21 for these specialized services. Knight Const. &amp; Supply, Inc., of Deer Park, WA, was the only bid received and was determined to be responsive and responsible. The resulting contract was for one year, from Nov. 1, 2021 through Oct. 31, 2022, with the possibility of four (4) one-year renewals. This will be the third renewal and will span from Nov. 1, 2024 through Oct. 31, 2025 and have an anticipated cost not to exceed \$2,200,000.00 plus tax.</p>
<p><b>Fiscal Impact</b></p> <p><b>Approved in current year budget?</b>    <input checked="" type="checkbox"/> Yes    <input type="checkbox"/> No    <input type="checkbox"/> N/A</p> <p>Total Cost: <u>\$2,200,000.00</u></p> <p>    Current year cost: \$2,200,000.00</p> <p>    Subsequent year(s) cost:</p> <p><b>Narrative:</b> <u>This is a routine repair and maintenance expense that was planned for in the Solid Waste Disposal budget.</u></p> <p><b>Funding Source</b>    <input type="checkbox"/> One-time    <input checked="" type="checkbox"/> Recurring    <input type="checkbox"/> N/A</p> <p>Specify funding source: Program revenue</p> <p>Is this funding source sustainable for future years, months, etc? Yes</p> <p><b>Expense Occurrence</b>    <input type="checkbox"/> One-time    <input checked="" type="checkbox"/> Recurring    <input type="checkbox"/> N/A</p> <p>Other budget impacts: (revenue generating, match requirements, etc.)</p>	
<p><b>Operations Impacts (If N/A, please give a brief description as to why)</b></p> <ul style="list-style-type: none"> <li>What impacts would the proposal have on historically excluded communities? Public works services and projects are designed to serve all citizens and businesses. We strive to offer a consistent level of service to all, to distribute public investment throughout the community and to respond to gaps in services identified in various City plans.</li> </ul>	

- How will data be collected, analyzed, and reported concerning the effect of the program/policy by racial, ethnic, gender identity, national origin, income level, disability, sexual orientation, or other existing disparities?

N/A

- How will data be collected regarding the effectiveness of this program, policy, or product to ensure it is the right solution?

Public Works follows the City's established procurement and public works bidding regulations and policies to bring items forward, and then uses contract management best practices to ensure desired outcomes and regulatory compliance.

- Describe how this proposal aligns with current City Policies, including the Comprehensive Plan, Sustainability Action Plan, Capital Improvement Program, Neighborhood Master Plans, Council Resolutions, and others?

This work is consistent with annual budget strategies to limit costs and approved projects in the 6-year CIP.

### **Council Subcommittee Review**

- Please provide a summary of council subcommittee review. If not reviewed by a council subcommittee, please explain why not.

Not applicable



**City of Spokane**  
**CONTRACT RENEWAL #3 of 4**  
**Title: WASTE TO ENERGY MECHANICAL REPAIRS**

This Contract Renewal is made and entered into by and between the **CITY OF SPOKANE** as ("City"), a Washington municipal corporation, and **KNIGHT CONST. & SUPPLY, INC.**, whose address is 2601 East 6<sup>th</sup> Street, Deer Park, Washington 99006 as ("Contractor"), individually hereafter referenced as a "Party", and together as the "Parties".

*WHEREAS, the parties entered into a Contract wherein the Company agreed to perform Mechanical Repairs at the Waste to Energy Facility; and*

*WHEREAS, the initial Contract provided for four (4) additional one (1) year renewals, with this being the third of those renewals.*

*-- NOW, THEREFORE, in consideration of these terms, the parties mutually agree as follows:*

**1. CONTRACT DOCUMENTS.**

The original Contract, dated November 11, 2021, any previous amendments, renewals and / or extensions / thereto, are incorporated by reference into this document as though written in full and shall remain in full force and effect except as provided herein.

**2. EFFECTIVE DATE.**

This Contract Renewal shall become effective on November 1, 2024, and shall end October 31, 2025.

**3. COMPENSATION.**

The City shall pay an estimated maximum annual cost not to exceed **TWO MILLION TWO HUNDRED THOUSAND AND 00/100 (\$2,200,000.00), plus applicable sales tax**, for everything furnished and done under this Contract Renewal. This is the maximum amount to be paid under this Renewal, and shall not be exceeded without the prior written authorization of the City, memorialized with the same formality as the original Contract and this Renewal document.

**4. DEBARMENT AND SUSPENSION.**

The Contractor has provided its certification that it is in compliance with and shall not contract with individuals or organizations which are debarred, suspended, or otherwise excluded from or ineligible from participation in Federal Assistance Programs under Executive Order 12549 and "Debarment and Suspension", codified at 29 CFR part 98 (see Exhibit A).

IN WITNESS WHEREOF, in consideration of the terms, conditions and covenants contained, or attached and incorporated and made a part, the parties have executed this Contract Renewal by having legally-binding representatives affix their signatures below.

**KNIGHT CONST. & SUPPLY, INC.**

**CITY OF SPOKANE**

By \_\_\_\_\_  
Signature Date

By \_\_\_\_\_  
Signature Date

\_\_\_\_\_  
Type or Print Name

\_\_\_\_\_  
Type or Print Name

\_\_\_\_\_  
Title

\_\_\_\_\_  
Title

Attest:

Approved as to form:

\_\_\_\_\_  
City Clerk

\_\_\_\_\_  
Assistant City Attorney

**Attachments that are part of this Agreement:**

- Exhibit A – Certificate Regarding Debarment
- Exhibit B – Knight Const. & Supply, Inc., 2025 Billing Rates

**EXHIBIT A**

**CERTIFICATION REGARDING DEBARMENT, SUSPENSION,  
INELIGIBILITY AND VOLUNTARY EXCLUSION**

1. The undersigned (i.e., signatory for the Subrecipient / Contractor / Consultant) certifies, to the best of its knowledge and belief, that it and its principals:
  - a. Are not presently debarred, suspended, proposed for debarment, declared ineligible, or voluntarily excluded from covered transactions by any federal department or agency;
  - b. Have not within a three-year period preceding this contract been convicted or had a civil judgment rendered against them for commission of fraud or a criminal offense in connection with obtaining, attempting to obtain, or performing a public (federal, state, or local) transaction or contract under a public transaction; violation of federal or state antitrust statutes or commission of embezzlement, theft, forgery, bribery, falsification or destruction of records, making false statements, tax evasion, receiving stolen property, making false claims, or obstruction of justice;
  - c. Are not presently indicted or otherwise criminally or civilly charged by a government entity (federal, state, or local) with commission of any of the offenses enumerated in paragraph (1)(b) of this certification; and,
  - d. Have not within a three-year period preceding this contract had one or more public transactions (federal, state, or local) terminated for cause or default.
  
2. The undersigned agrees by signing this contract that it shall not knowingly enter into any lower tier covered transaction with a person who is debarred, suspended, declared ineligible, or voluntarily excluded from participation in this covered transaction.
  
3. The undersigned further agrees by signing this contract that it will include the following clause, without modification, in all lower tier covered transactions and in all solicitations for lower tier covered transactions:

Certification Regarding Debarment, Suspension, Ineligibility and Voluntary Exclusion – Lower Tier Covered Transactions

1. The lower tier contractor certifies, by signing this contract that neither it nor its principals is presently debarred, suspended, proposed for debarment, declared ineligible, or voluntarily excluded from participation in this transaction by any federal department or agency.
  
  2. Where the lower tier contractor is unable to certify to any of the statements in this contract, such contractor shall attach an explanation to this contract.
4. I understand that a false statement of this certification may be grounds for termination of the contract.

_____ Name of Subrecipient / Contractor / Consultant (Type or Print)	_____ Program Title (Type or Print)
_____ Name of Certifying Official (Type or Print)	_____ Signature
_____ Title of Certifying Official (Type or Print)	_____ Date (Type or Print)

**EXHIBIT B**



< Business Lookup

### License Information:

[New search](#) [Back to results](#)

**Entity name:** KNIGHT CONST. & SUPPLY, INC.

**Business name:** KNIGHT CONST. & SUPPLY, INC.

**Entity type:** [Profit Corporation](#)

**UBI #:** 600-074-664

**Business ID:** 001

**Location ID:** 0001

**Location:** Active

**Location address:** 2601 E 6TH ST  
DEER PARK WA 99006-5381

**Mailing address:** 2601 E 6TH ST  
DEER PARK WA 99006-5381

**Excise tax and reseller permit status:** [Click here](#)

**Secretary of State status:** [Click here](#)

### Endorsements

Endorsements held at this location	License #	Count	Details	Status	Expiration date	First issuance date
<a href="#">Deer Park General Business</a>				Active	Jul-31-2025	Sep-21-2020
<a href="#">Millwood General Business - Non-Resident</a>				Active	Jul-31-2025	Aug-10-2023
<a href="#">Minor Work Permit</a>				Active	Jul-31-2025	Jul-21-1995
<a href="#">Spokane General Business - Non-Resident</a>	T12001102BUS			Active	Jul-31-2025	Oct-15-2012
<a href="#">Spokane Valley General Business - Non-Resident</a>				Active	Jul-31-2025	Nov-28-2022

### Governing People May include governing people not registered with Secretary of State

Governing people	Title
KNIGHT, DAVID	
KNIGHT, DOUGLAS J	

The Business Lookup information is updated nightly. Search date and time: 9/30/2024 11:14:53 AM

[Contact us](#)

How are we doing?  
[Take our survey!](#)

Don't see what you expected?  
[Check if your browser is supported](#)





< Business Lookup

### License Information:

[New search](#) [Back to results](#)

**Entity name:** KNIGHT CONST. & SUPPLY, INC.

**Business name:** KNIGHT CONST. & SUPPLY, INC.

**Entity type:** [Profit Corporation](#)

**UBI #:** 600-074-664

**Business ID:** 001

**Location ID:** 0001

**Location:** Active

**Location address:** 2601 E 6TH ST  
DEER PARK WA 99006-5381

**Mailing address:** 2601 E 6TH ST  
DEER PARK WA 99006-5381

**Excise tax and reseller permit status:** [Click here](#)

**Secretary of State status:** [Click here](#)

### Endorsements

Endorsements held at this location	License #	Count	Details	Status	Expiration date	First issuance date
<a href="#">Deer Park General Business</a>				Active	Jul-31-2025	Sep-21-2020
<a href="#">Millwood General Business - Non-Resident</a>				Active	Jul-31-2025	Aug-10-2023
<a href="#">Minor Work Permit</a>				Active	Jul-31-2025	Jul-21-1995
<a href="#">Spokane General Business - Non-Resident</a>	T12001102BUS			Active	Jul-31-2025	Oct-15-2012
<a href="#">Spokane Valley General Business - Non-Resident</a>				Active	Jul-31-2025	Nov-28-2022

### Governing People May include governing people not registered with Secretary of State

Governing people	Title
KNIGHT, DAVID	
KNIGHT, DOUGLAS J	

The Business Lookup information is updated nightly. Search date and time: 9/30/2024 11:14:53 AM

[Contact us](#)

How are we doing?  
[Take our survey!](#)

Don't see what you expected?  
[Check if your browser is supported](#)







KNIGCON-01

MNEIGHBORS

# CERTIFICATE OF LIABILITY INSURANCE

DATE (MM/DD/YYYY)

8/14/2024

THIS CERTIFICATE IS ISSUED AS A MATTER OF INFORMATION ONLY AND CONFERS NO RIGHTS UPON THE CERTIFICATE HOLDER. THIS CERTIFICATE DOES NOT AFFIRMATIVELY OR NEGATIVELY AMEND, EXTEND OR ALTER THE COVERAGE AFFORDED BY THE POLICIES BELOW. THIS CERTIFICATE OF INSURANCE DOES NOT CONSTITUTE A CONTRACT BETWEEN THE ISSUING INSURER(S), AUTHORIZED REPRESENTATIVE OR PRODUCER, AND THE CERTIFICATE HOLDER.

**IMPORTANT:** If the certificate holder is an ADDITIONAL INSURED, the policy(ies) must have ADDITIONAL INSURED provisions or be endorsed. If SUBROGATION IS WAIVED, subject to the terms and conditions of the policy, certain policies may require an endorsement. A statement on this certificate does not confer rights to the certificate holder in lieu of such endorsement(s).

<b>PRODUCER</b> Spokane Office Marsh McLennan Agency LLC 501 N. Riverpoint Blvd., Ste 403 Spokane, WA 99202	<b>CONTACT NAME:</b> James Clegg <b>PHONE (A/C, No, Ext):</b> (509) 789-7438 <b>FAX (A/C, No):</b> <b>E-MAIL ADDRESS:</b> James.Clegg@MarshMMA.com
	<b>INSURER(S) AFFORDING COVERAGE</b> <b>INSURER A:</b> Cincinnati Insurance Company <b>INSURER B:</b> Cincinnati Indemnity Company <b>INSURER C:</b> <b>INSURER D:</b> <b>INSURER E:</b> <b>INSURER F:</b>

**COVERAGES**                      **CERTIFICATE NUMBER:**                      **REVISION NUMBER:**

THIS IS TO CERTIFY THAT THE POLICIES OF INSURANCE LISTED BELOW HAVE BEEN ISSUED TO THE INSURED NAMED ABOVE FOR THE POLICY PERIOD INDICATED. NOTWITHSTANDING ANY REQUIREMENT, TERM OR CONDITION OF ANY CONTRACT OR OTHER DOCUMENT WITH RESPECT TO WHICH THIS CERTIFICATE MAY BE ISSUED OR MAY PERTAIN, THE INSURANCE AFFORDED BY THE POLICIES DESCRIBED HEREIN IS SUBJECT TO ALL THE TERMS, EXCLUSIONS AND CONDITIONS OF SUCH POLICIES. LIMITS SHOWN MAY HAVE BEEN REDUCED BY PAID CLAIMS.

INSR LTR	TYPE OF INSURANCE	ADDL INSD	SUBR WVD	POLICY NUMBER	POLICY EFF (MM/DD/YYYY)	POLICY EXP (MM/DD/YYYY)	LIMITS
A	<b>COMMERCIAL GENERAL LIABILITY</b> <input type="checkbox"/> CLAIMS-MADE <input checked="" type="checkbox"/> OCCUR  GEN'L AGGREGATE LIMIT APPLIES PER: <input type="checkbox"/> POLICY <input checked="" type="checkbox"/> PRO-JECT <input type="checkbox"/> LOC OTHER:	X	X	ENP 0587046	8/19/2024	8/19/2025	EACH OCCURRENCE \$ 1,000,000 DAMAGE TO RENTED PREMISES (Ea occurrence) \$ 500,000 MED EXP (Any one person) \$ 10,000 PERSONAL & ADV INJURY \$ 1,000,000 GENERAL AGGREGATE \$ 2,000,000 PRODUCTS - COMP/OP AGG \$ 2,000,000 <b>WA STOP GAP</b> \$ 1,000,000
B	<b>AUTOMOBILE LIABILITY</b> <input checked="" type="checkbox"/> ANY AUTO OWNED AUTOS ONLY <input type="checkbox"/> SCHEDULED AUTOS <input type="checkbox"/> HIRED AUTOS ONLY <input type="checkbox"/> NON-OWNED AUTOS ONLY	X	X	ENP 0586986	8/19/2024	8/19/2025	COMBINED SINGLE LIMIT (Ea accident) \$ 1,000,000 BODILY INJURY (Per person) \$ BODILY INJURY (Per accident) \$ PROPERTY DAMAGE (Per accident) \$
A	<b>UMBRELLA LIAB</b> <input checked="" type="checkbox"/> OCCUR <b>EXCESS LIAB</b> <input type="checkbox"/> CLAIMS-MADE DED <input checked="" type="checkbox"/> RETENTION \$    0			ENP 0587046	8/19/2024	8/19/2025	EACH OCCURRENCE \$ 1,000,000 AGGREGATE \$ 1,000,000
	<b>WORKERS COMPENSATION AND EMPLOYERS' LIABILITY</b> ANY PROPRIETOR/PARTNER/EXECUTIVE OFFICER/MEMBER EXCLUDED? (Mandatory in NH)    Y/N <input type="checkbox"/> If yes, describe under DESCRIPTION OF OPERATIONS below		N/A				PER STATUTE    OTH-ER E.L. EACH ACCIDENT \$ E.L. DISEASE - EA EMPLOYEE \$ E.L. DISEASE - POLICY LIMIT \$

DESCRIPTION OF OPERATIONS / LOCATIONS / VEHICLES (ACORD 101, Additional Remarks Schedule, may be attached if more space is required)  
 Project: Waste To Energy Mechanical Repairs

City of Spokane is additional insured, on a primary/non-contributory basis, including waiver of subrogation, as per the attached forms.

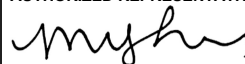
<b>CERTIFICATE HOLDER</b>  City of Spokane 808 W. Spokane Falls Blvd Spokane, WA 99201-3316	<b>CANCELLATION</b>  SHOULD ANY OF THE ABOVE DESCRIBED POLICIES BE CANCELLED BEFORE THE EXPIRATION DATE THEREOF, NOTICE WILL BE DELIVERED IN ACCORDANCE WITH THE POLICY PROVISIONS.  AUTHORIZED REPRESENTATIVE 
---	--

THIS ENDORSEMENT CHANGES THE POLICY. PLEASE READ IT CAREFULLY.

## CONTRACTORS ADDITIONAL INSURED - AUTOMATIC STATUS AND AUTOMATIC WAIVER OF SUBROGATION WHEN REQUIRED IN WRITTEN CONTRACT, AGREEMENT, PERMIT OR AUTHORIZATION

This endorsement modifies insurance provided under the following:

### COMMERCIAL GENERAL LIABILITY COVERAGE PART

#### A. Additional Insured - Owners, Lessees Or Contractors - Automatic Status For Other Parties When Required In Written Contract Or Agreement With You

1. **Section II - Who Is An Insured** is amended to include as an additional insured any person or organization you have agreed in writing in a contract or agreement to add as an additional insured on this Coverage Part. Such person(s) or organization(s) is an additional insured only with respect to liability for:

a. "Bodily injury", "property damage" or "personal and advertising injury" *caused, in whole or in part, by* the performance of your ongoing operations by you or on your behalf, under that written contract or written agreement. Ongoing operations does not apply to "bodily injury" or "property damage" occurring after:

(1) All work, including materials, parts or equipment furnished in connection with such work, on the project (other than service, maintenance or repairs) to be performed by or on behalf of the additional insured(s) at the location of the covered operations has been completed; or

(2) That portion of "your work" out of which the injury or damage arises has been put to its intended use by any person or organization other than another contractor or subcontractor engaged in performing operations for a principal as a part of the same project; and

b. "Bodily injury" or "property damage" *caused, in whole or in part, by* "your work" performed under that written contract or written agreement and in-

cluded in the "products-completed operations hazard", but only if:

(1) The Coverage Part to which this endorsement is attached provides coverage for "bodily injury" or "property damage" included within the "products-completed operations hazard"; and

(2) The written contract or written agreement requires you to provide additional insured coverage included within the "products-completed operations hazard" for that person or organization.

If the written contract or written agreement requires you to provide additional insured coverage included within the "products-completed operations hazard" for a specified length of time for that person or organization, the "bodily injury" or "property damage" must occur prior to the expiration of that period of time in order for this insurance to apply.

If the written contract or written agreement requires you to provide additional insured coverage for a person or organization per only ISO additional insured endorsement form number **CG 20 10**, without specifying an edition date, and without specifically requiring additional insured coverage included within the "products-completed operations hazard", this Paragraph **b.** does not apply to that person or organization.

2. If the written contract or written agreement described in Paragraph **1.** above specifically requires you to provide additional insured coverage to that person or organization:

a. *Arising out of* your ongoing operations or *arising out of* "your work"; or

- b. By way of an edition of an ISO additional insured endorsement that includes *arising out of* your ongoing operations or *arising out of* "your work";

then the phrase *caused, in whole or in part, by* in Paragraph **A.1.a.** and/or Paragraph **A.1.b.** above, whichever applies, is replaced by the phrase *arising out of*.

- 3. With respect to the insurance afforded to the additional insureds described in Paragraph **A.1.**, the following additional exclusion applies:

This insurance does not apply to "bodily injury", "property damage" or "personal and advertising injury" arising out of the rendering of, or the failure to render, any professional architectural, engineering or surveying services, including:

- a. The preparing, approving or failing to prepare or approve, maps, shop drawings, opinions, reports, surveys, field orders, change orders or drawings and specifications; or
- b. Supervisory, inspection, architectural or engineering activities.

This exclusion applies even if the claims against any insured allege negligence or other wrongdoing in the supervision, hiring, employment, training or monitoring of others by that insured, if the "occurrence" which caused the "bodily injury" or "property damage", or the offense which caused the "personal and advertising injury", involved the rendering of, or the failure to render, any professional architectural, engineering or surveying services.

- 4. This Paragraph **A.** does not apply to additional insureds described in Paragraph **B.**

**B. Additional Insured - State Or Governmental Agency Or Subdivision Or Political Subdivision - Automatic Status When Required In Written Permits Or Authorizations**

- 1. **Section II - Who Is An Insured** is amended to include as an additional insured any state or governmental agency or subdivision or political subdivision you have agreed in writing in a permit or authorization to add as an additional insured on this Coverage Part. Such state or governmental agency or subdivision or political subdivision is an additional insured only with respect to operations performed by you or on your behalf for which the state or governmental agency or subdivision or political subdivision has issued, in writing, a permit or authorization.

- 2. With respect to the insurance afforded to the additional insureds described in Paragraph **B.1.**, the following additional exclusions apply:

This insurance does not apply to:

- a. "Bodily injury", "property damage" or "personal and advertising injury" arising out of operations performed for the federal government, state or municipality; or
- b. "Bodily injury" or "property damage" included within the "products-completed operations hazard."

- C. The insurance afforded to additional insureds described in Paragraphs **A.** and **B.**:

- 1. Only applies to the extent permitted by law; and
- 2. Will not be broader than that which you are required by the written contract, written agreement, written permit or written authorization to provide for such additional insured; and
- 3. Does not apply to any person, organization, state, governmental agency or subdivision or political subdivision specifically named as an additional insured for the same project in the schedule of an endorsement added to this Coverage Part.

- D. With respect to the insurance afforded to the additional insureds described in Paragraphs **A.** and **B.**, the following is added to **Section III - Limits Of Insurance**:

The most we will pay on behalf of the additional insured is the amount of insurance:

- 1. Required by the written contract, written agreement, written permit or written authorization described in Paragraphs **A.** and **B.** For the purpose of determining the required amount of insurance only, we will include the minimum amount of any Umbrella Liability or Excess Liability coverage required for that additional insured in that written contract, written agreement, written permit or written authorization; or
- 2. Available under the applicable limits of insurance;

whichever is less.

This endorsement shall not increase the applicable limits of insurance.

- E. **Section IV - Commercial General Liability Conditions** is amended to add the following:

**Automatic Additional Insured Provision**

This insurance applies only if the "bodily injury" or "property damage" occurs, or the "personal and advertising injury" offense is committed:

1. During the policy period; and
  2. Subsequent to your execution of the written contract or written agreement, or the issuance of a written permit or written authorization, described in Paragraphs **A.** and **B.**
- F. Except when **G.** below applies, the following is added to **Section IV - Commercial General Liability Conditions, Other Insurance,** and supersedes any provision to the contrary:

**When Other Additional Insured Coverage Applies On An Excess Basis**

This insurance is primary to other insurance available to the additional insured described in Paragraphs **A.** and **B.** except:

1. As otherwise provided in **Section IV - Commercial General Liability Conditions, Other Insurance, b. Excess Insurance;** or
  2. For any other valid and collectible insurance available to the additional insured as an additional insured on another insurance policy that is written on an excess basis. In such case, this insurance is also excess.
- G. The following is added to **Section IV - Commercial General Liability Conditions, Other Insurance,** and supersedes any provision to the contrary:

**Primary Insurance When Required By Written Contract, Agreement, Permit Or Authorization**

Except when wrap-up insurance applies to the claim or "suit" on behalf of the additional insured, this insurance is primary to any other insurance available to the additional insured described in Paragraphs **A.** and **B.** provided that:

1. The additional insured is a Named Insured under such other insurance; and
2. You have agreed in writing in a contract, agreement, permit or authorization de-

scribed in Paragraph **A.** or **B.** that this insurance would be primary to any other insurance available to the additional insured.

As used in this endorsement, wrap-up insurance means a centralized insurance program under which one party has secured either insurance or self-insurance covering some or all of the contractors or subcontractors performing work on one or more specific project(s).

**Primary And Noncontributory Insurance When Required By Written Contract, Agreement, Permit Or Authorization**

Except when wrap-up insurance applies to the claim or "suit" on behalf of the additional insured, this insurance is primary to and will not seek contribution from any other insurance available to the additional insured described in Paragraphs **A.** and **B.** provided that:

1. The additional insured is a Named Insured under such other insurance; and
2. You have agreed in writing in a contract, agreement, permit or authorization described in Paragraph **A.** or **B.** that this insurance would be primary and would not seek contribution from any other insurance available to the additional insured.

As used in this endorsement, wrap-up insurance means a centralized insurance program under which one party has secured either insurance or self-insurance covering some or all of the contractors or subcontractors performing work on one or more specific project(s).

- H. **Section IV - Commercial General Liability Conditions, Transfer Of Rights Of Recovery Against Others To Us** is amended by the addition of the following:

**Waiver of Subrogation**

We waive any right of recovery against any additional insured under this endorsement, because of any payment we make under this endorsement, to whom the insured has waived its right of recovery in a written contract, written agreement, written permit or written authorization. Such waiver by us applies only to the extent that the insured has waived its right of recovery against such additional insured prior to loss.

**THIS ENDORSEMENT CHANGES THE POLICY. PLEASE READ IT CAREFULLY.**

## **DESIGNATED CONSTRUCTION PROJECT(S) GENERAL AGGREGATE LIMIT**

This endorsement modifies insurance provided under the following:

COMMERCIAL GENERAL LIABILITY COVERAGE PART  
**SCHEDULE**

**Designated Construction Project(s):**

ANY JOB SITE

Information required to complete this Schedule, if not shown above, will be shown in the Declarations.

- A.** For all sums which the insured becomes legally obligated to pay as damages caused by "occurrences" under Section I - Coverage **A**, and for all medical expenses caused by accidents under Section I - Coverage **C**, which can be attributed only to ongoing operations at a single designated construction project shown in the Schedule above:
1. A separate Designated Construction Project General Aggregate Limit applies to each designated construction project, and that limit is equal to the amount of the General Aggregate Limit shown in the Declarations.
  2. The Designated Construction Project General Aggregate Limit is the most we will pay for the sum of all damages under Coverage **A**, except damages because of "bodily injury" or "property damage" included in the "products-completed operations hazard", and for medical expenses under Coverage **C** regardless of the number of:
    - a. Insureds;
    - b. Claims made or "suits" brought; or
    - c. Persons or organizations making claims or bringing "suits".
  3. Any payments made under Coverage **A** for damages or under Coverage **C** for medical expenses shall reduce the Designated Construction Project General Aggregate Limit for that designated construction project. Such payments shall not reduce the General Aggregate Limit shown in the Declarations nor shall they reduce any other Designated Construction Project General Aggregate Limit for any other designated construction project shown in the Schedule above.
- B.** For all sums which the insured becomes legally obligated to pay as damages caused by "occurrences" under Section I - Coverage **A**, and for all medical expenses caused by accidents under Section I - Coverage **C**, which cannot be attributed only to ongoing operations at a single designated construction project shown in the Schedule above:
1. Any payments made under Coverage **A** for damages or under Coverage **C** for medical expenses shall reduce the amount available under the General Aggregate Limit or the Products-completed Operations Aggregate Limit, whichever is applicable; and
  2. Such payments shall not reduce any Designated Construction Project General Aggregate Limit.
- C.** When coverage for liability arising out of the "products-completed operations hazard" is provided, any payments for damages because

of "bodily injury" or "property damage" included in the "products-completed operations hazard" will reduce the Products-completed Operations Aggregate Limit, and not reduce the General Aggregate Limit nor the Designated Construction Project General Aggregate Limit.

**D.** If the applicable designated construction project has been abandoned, delayed, or aban-

doned and then restarted, or if the authorized contracting parties deviate from plans, blueprints, designs, specifications or timetables, the project will still be deemed to be the same construction project.

**E.** The provisions of Section III - Limits Of Insurance not otherwise modified by this endorsement shall continue to apply as stipulated.

**THIS ENDORSEMENT CHANGES THE POLICY. PLEASE READ IT CAREFULLY.**

**CinciPlus®**  
**BUSINESS AUTO XC+®**  
**(EXPANDED COVERAGE PLUS)**  
**ENDORSEMENT**

This endorsement modifies insurance provided by the following:

**BUSINESS AUTO COVERAGE FORM**

With respect to the coverage provided by this endorsement, the provisions of the Coverage Form apply unless modified by this endorsement.

**A. Blanket Waiver of Subrogation**

**SECTION IV - BUSINESS AUTO CONDITIONS, A. Loss Conditions, 5. Transfer of Rights of Recovery Against Others to Us** is amended by the addition of the following:

We waive any right of recovery we may have against any person or organization because of payments we make for "bodily injury" or "property damage" arising out of the operation of a covered "auto" when you have assumed liability for such "bodily injury" or "property damage" under an "insured contract", provided the "bodily injury" or "property damage" occurs subsequent to the execution or the "insured contract".

**B. Noncontributory Insurance**

**SECTION IV - BUSINESS AUTO CONDITIONS, B. General Conditions, 5. Other Insurance c.** is deleted in its entirety and replaced by the following:

- c. Regardless of the provisions of Paragraph a. above, this Coverage Form's Liability Coverage is primary and we will not seek contribution from any other insurance for any liability assumed under an "insured contract" that requires liability to be assumed on a primary noncontributory basis.

**C. Additional Insured by Contract**

**SECTION II - LIABILITY COVERAGE, A. Coverage, 1. Who is an Insured** is amended to include as an insured any person or organization for whom you have agreed in a valid written contract to provide insurance as afforded by this policy.

This provision is limited to the scope of the valid written contract.

This provision does not apply unless the valid written contract has been:

1. Executed prior to the accident causing "bodily injury" or "property damage"; and
2. Is still in force at the time of the "accident" causing "bodily injury" or "property damage".

**D. Employee Hired Auto**

**1. Changes in Liability Coverage**

The following is added to the **SECTION II - LIABILITY COVERAGE, A. Coverage, 1. Who is an Insured**:

An "employee" of yours is an "insured" while operating an "auto" hired or rented under a contract or agreement in that "employee's" name, with your permission, while performing duties related to the conduct of your business.

**2. Changes in General Conditions**

**SECTION IV - BUSINESS AUTO CONDITIONS, B. General Conditions, 5. Other Insurance** is deleted in its entirety and replaced by the following:

- b. For Hired Auto Physical Damage Coverage the following are deemed to be covered "autos" you own:

- (1) Any covered "auto" you lease, hire, rent or borrow; and
- (2) Any covered "auto" hired or rented by your "employee" under a contract in that individual "employee's" name, with your permission, while performing duties related to the conduct of your business.

However, any "auto" that is leased, hired, rented or borrowed with a driver is not a covered "auto".

#### **E. Audio, Visual and Data Electronic Equipment**

**SECTION III - PHYSICAL DAMAGE COVERAGE, C. Limit of Insurance** is amended by adding the following:

4. The most we will pay for all "loss" to audio, visual or data electronic equipment and any accessories used with this equipment as a result of any one "accident" is the lesser of:
  - a. The actual cash value of the damaged or stolen property as of the time of the "accident";
  - b. The cost of repairing or replacing the damaged or stolen property with other property of like kind and quality; or
  - c. \$2,500.

Provided the equipment, at the time of the "loss" is:

- a. Permanently installed in or upon the covered "auto" in a housing, opening or other location that is not normally used by the "auto" manufacturer for the installation of such equipment;
- b. Removable from a permanently installed housing unit as described in Paragraph 2.a. above; or
- c. An integral part of such equipment.

#### **F. Who is an Insured - Amended**

**SECTION II - LIABILITY COVERAGE, A. Coverage, 1. Who is an Insured** is amended by adding the following:

The following are "insureds":

1. Any subsidiary which is a legally incorporated entity of which you own a financial interest of more than 50% of the voting stock on the effective date of this coverage form.

However, the insurance afforded by this provision does not apply to any subsidiary that is an "insured" under any other automobile liability policy or would be an "insured" under such policy but for termination of such policy or the exhaustion of such policy's limits of insurance.

2. Any organization that is newly acquired or formed by you and over which you maintain majority ownership. The insurance provided by this provision:

- a. Is effective on the date of acquisition or formation, and is afforded for 180 days after such date;
  - b. Does not apply to "bodily injury" or "property damage" resulting from an "accident" that occurred before you acquired or formed the organization;
  - c. Does not apply to any newly acquired or formed organization that is a joint venture or partnership; and
  - d. Does not apply to an insured under any other automobile liability policy or would be an insured under such a policy but for the termination of such policy or the exhaustion of such policy's limits of insurance.
3. Any of your "employees" while using a covered "auto" in your business or your personal affairs, provided you do not own, hire or borrow that "auto".

#### **G. Liability Coverage Extensions - Supplementary Payments - Higher Limits**

**SECTION II - LIABILITY COVERAGE, A. Coverage, 2. Coverage Extensions, a. Supplementary Payments** is amended by:

1. Replacing the \$2,000 Limit of Insurance for bail bonds with \$4,000 in (2); and
2. Replacing the \$250 Limit of Insurance for reasonable expenses with \$500 in (4).

#### **H. Amended Fellow Employee Exclusion**

**SECTION II - LIABILITY COVERAGE, B. Exclusions, 5. Fellow Employee** is modified as follows:

Exclusion 5. **Fellow Employee** is deleted.

#### **I. Hired Auto - Physical Damage**

If hired "autos" are covered "autos" for Liability Coverage, then Comprehensive and Collision Physical Damage Coverages as provided under **SECTION III - PHYSICAL DAMAGE COVERAGE** of this Coverage Part are extended to "autos" you hire, subject to the following:

1. The most we will pay for "loss" to any hired "auto" is \$50,000 or the actual cash value or cost to repair or replace, whichever is the least, minus a deductible.
2. The deductible will be equal to the largest deductible applicable to any owned "auto" for that coverage, or \$1,000, whichever is less.
3. Hired Auto - Physical Damage coverage is excess over any other collectible insurance.



4. Subject to the above limit, deductible, and excess provisions we will provide coverage equal to the broadest coverage applicable to any covered "auto" you own insured under this policy.

Coverage includes loss of use of that hired auto, provided it results from an "accident" for which you are legally liable and as a result of which a monetary loss is sustained by the leasing or rental concern. The most we will pay for any one "accident" is \$3,000.

If a limit for Hired Auto - Physical Damage is shown in the Schedule, then that limit replaces, and is not added to, the \$50,000 limit indicated above and the deductibles shown in the Schedule are applicable.

#### J. Rental Reimbursement

**SECTION III - PHYSICAL DAMAGE COVERAGE** is amended by adding the following:

1. We will pay for rental reimbursement expenses incurred by you for the rental of an "auto" because of a "loss" to a covered "auto". Payment applies in addition to the otherwise applicable amount of each coverage you have on a covered "auto". No deductible applies to this coverage.
2. We will pay only for those expenses incurred during the policy period beginning 24 hours after the "loss" and ending, regardless of the policy's expiration, with the lesser of the following number of days:
  - a. The number of days reasonably required to repair the covered "auto". If "loss" is caused by theft, this number of days is added to the number of days it takes to locate the covered "auto" and return it to you; or
  - b. 30 days.
3. Our payment is limited to the lesser of the following amounts:
  - a. Necessary and actual expenses incurred; or
  - b. \$50 per day.
4. This coverage does not apply while there are spare or reserve "autos" available to you for your operations.
5. We will pay under this coverage only that amount of your rental reimbursement expenses which is not already provided for under **SECTION III - PHYSICAL DAMAGE COVERAGE, A. Coverage, 4. Coverage Extensions**.

#### K. Transportation Expense - Higher Limits

**SECTION III - PHYSICAL DAMAGE COVERAGE, A. Coverage, 4. Coverage Extensions** is amended by replacing \$20 per day with \$50 per day, and \$600 maximum with \$1,500 maximum in **Extension a. Transportation Expenses**.

#### L. Airbag Coverage

**SECTION III - PHYSICAL DAMAGE COVERAGE, B. Exclusions, 3.a.** is amended by adding the following:

However, the mechanical and electrical breakdown portion of this exclusion does not apply to the accidental discharge of an airbag. This coverage for airbags is excess over any other collectible insurance or warranty.

#### M. Loan or Lease Gap Coverage

1. **SECTION III - PHYSICAL DAMAGE COVERAGE, C. Limit of Insurance** is deleted in its entirety and replaced by the following, but only for private passenger type "autos" with an original loan or lease, and only in the event of a "total loss" to such a private passenger type "auto":
  - a. The most we will pay for "loss" in any one "accident" is the greater of:
    - (1) The amount due under the terms of the lease or loan to which your covered private passenger type "auto" is subject, but will not include:
      - (a) Overdue lease or loan payments;
      - (b) Financial penalties imposed under the lease due to high mileage, excessive use or abnormal wear and tear;
      - (c) Security deposits not refunded by the lessor;
      - (d) Costs for extended warranties, Credit Life Insurance, Health, Accident or Disability Insurance purchased with the loan or lease; and
      - (e) Carry-over balances from previous loans or leases, or
    - (2) Actual cash value of the stolen or damaged property.
  - b. An adjustment for depreciation and physical condition will be made in determining actual cash value at the time of "loss".

2. **SECTION V - DEFINITIONS** is amended by adding the following, but only for the purposes of this **Loan or Lease Gap Coverage**:

"Total loss" means a "loss" in which the cost of repairs plus the salvage value exceeds the actual cash value.

**N. Glass Repair - Waiver of Deductible**

**SECTION III - PHYSICAL DAMAGE COVERAGE, D. Deductible** is amended by adding the following:

No deductible applies to glass damage if the glass is repaired in a manner acceptable to us rather than replaced.

**O. Duties in the Event of an Accident, Claim, Suit or Loss - Amended**

**SECTION IV - BUSINESS AUTO CONDITIONS, A. Loss Conditions, 2. Duties in the Event of Accident, Claim, Suit or Loss, a.** is amended by adding the following:

This condition applies only when the "accident" or "loss" is known to:

1. You, if you are an individual;
2. A partner, if you are a partnership;
3. An executive officer or insurance manager, if you are a corporation; or
4. A member or manager, if you are a limited liability company.

**P. Unintentional Failure to Disclose Hazards**

**SECTION IV - BUSINESS AUTO CONDITIONS, B. General Conditions, 2. Concealment, Misrepresentation or Fraud** is amended by adding the following:

However, if you unintentionally fail to disclose any hazards existing on the effective date of this Coverage Form, we will not deny coverage under this Coverage Form because of such failure.

**Q. Mental Anguish Resulting from Bodily Injury**

**SECTION V - DEFINITIONS, C. "Bodily injury"** is deleted in its entirety and replaced by the following:

"Bodily injury" means bodily injury, sickness or disease sustained by a person, including mental anguish and death sustained by the same person that results from such bodily injury, sickness or disease. "Bodily injury" does not include mental anguish or death that does not result from bodily injury, sickness or disease.

**R. Coverage for Certain Operations in Connection with Railroads**

With respect to the use of a covered "auto" in operations for or affecting a railroad:

1. **SECTION V - DEFINITIONS, H. "Insured contract", 1.c.** is deleted in its entirety and replaced by the following:
  - c. An easement or license agreement;
2. **SECTION V - DEFINITIONS, H. "Insured contract", 2.a.** is deleted.

**THIS ENDORSEMENT CHANGES THE POLICY. PLEASE READ IT CAREFULLY.**

## **CANCELLATION OR NONRENEWAL BY US NOTIFICATION TO A DESIGNATED ENTITY**

This endorsement modifies insurance provided under the following:

**BUSINESSOWNERS PACKAGE POLICY  
CLAIMS-MADE EXCESS LIABILITY COVERAGE PART  
COMMERCIAL AUTO COVERAGE PART  
COMMERCIAL GENERAL LIABILITY COVERAGE PART  
COMMERCIAL UMBRELLA LIABILITY COVERAGE PART  
DENTIST'S PACKAGE POLICY  
ELECTRONIC DATA LIABILITY COVERAGE PART  
EXCESS LIABILITY COVERAGE PART  
LIQUOR LIABILITY COVERAGE PART  
OWNERS AND CONTRACTORS PROTECTIVE LIABILITY COVERAGE PART  
POLLUTION LIABILITY COVERAGE PART  
PRODUCTS/COMPLETED OPERATIONS COVERAGE PART  
PRODUCT WITHDRAWAL COVERAGE PART  
PROFESSIONAL LIABILITY COVERAGE PART  
PROFESSIONAL UMBRELLA LIABILITY COVERAGE PART  
PROFESSIONAL UMBRELLA LIABILITY COVERAGE PART - CLAIMS-MADE  
RAILROAD PROTECTIVE LIABILITY COVERAGE PART  
UNDERGROUND STORAGE TANK POLICY**

### **SCHEDULE**

Name and mailing address of person(s) or organization(s):

BLANKET WHEN REQUIRED BY WRITTEN CONTRACT OR AGREEMENT

Number of days notice (other than nonpayment of premium): 30

- A.** If we cancel or nonrenew this policy for any statutorily permitted reason other than nonpayment of premium we will mail notice to the person or organization shown in the Schedule. We will mail such notice at least the number of days shown in the Schedule before the effective date of cancellation or nonrenewal.
- B.** If we cancel this policy for nonpayment of premium, we will mail notice to the person or organization shown in the Schedule. We will mail such notice at least 10 days before the effective date of cancellation.
- C.** If notice is mailed, proof of mailing to the mailing address shown in the Schedule will be sufficient proof of notice.
- D.** In no event will coverage extend beyond the actual expiration, termination or cancellation of the policy.



## EVANSTON INSURANCE COMPANY

### ADVANTAGE CONTRACTOR'S POLLUTION LIABILITY PLUS COVERAGE FORM

VARIOUS PROVISIONS IN THIS POLICY MAY RESTRICT OR EXCLUDE COVERAGE. PLEASE READ THE ENTIRE POLICY CAREFULLY TO DETERMINE THE INSURED'S RIGHTS AND DUTIES AND WHAT IS AND IS NOT COVERED.

THE PROFESSIONAL LIABILITY INSURING AGREEMENT, PROFESSIONAL LIABILITY RECTIFICATION EXPENSE INSURING AGREEMENT, AND DISCIPLINARY PROCEEDING LEGAL EXPENSE REIMBURSEMENT COVERAGE EXTENSION PROVIDE CLAIMS-MADE AND REPORTED COVERAGE AND REQUIRE THAT A CLAIM BE FIRST MADE AGAINST THE INSURED DURING THE POLICY PERIOD AND REPORTED TO THE COMPANY IN WRITING DURING THE POLICY PERIOD OR ANY APPLICABLE EXTENDED REPORTING PERIOD WE PROVIDE UNDER SECTION V - EXTENDED REPORTING PERIOD.

AMOUNTS INCURRED AS SUPPLEMENTARY PAYMENTS WILL BE APPLIED AGAINST THE APPLICABLE SELF-INSURED RETENTION. ANY AMOUNTS INCURRED AS SUPPLEMENTARY PAYMENTS IN EXCESS OF THE DEFENSE EXPENSES AGGREGATE LIMIT SHOWN IN THE DECLARATIONS WILL REDUCE THE LIMIT OF INSURANCE AVAILABLE.

Throughout this policy the words "you" and "your" refer to the Named Insured shown in the Declarations and any other person or organization qualifying as a Named Insured under this policy. The word "insured" means any person or organization qualifying as such under Section III - Who Is An Insured. The words "we", "us", and "our" refer to the company providing this insurance. Other words and phrases that appear in quotation marks have special meaning. Refer to Section VII - Definitions.

#### SECTION I - COVERAGES

##### A. Insuring Agreements

Although various Insuring Agreements may be referenced in this policy, an Insuring Agreement is included within this policy only if that Insuring Agreement is designated as purchased by an "X" in the Declarations.

1. The following Insuring Agreements apply only if the "pollution condition" that causes a "pollution loss" takes place in the "coverage territory". The amount we will pay is limited as described in Section IV - Limits Of Insurance And Self-Insured Retention.

##### a. Contractor's Pollution Liability (Including Mold And Legionella)

We will pay on behalf of the insured those sums in excess of the Pollution Liability Self-Insured Retention shown in the Declarations that the insured becomes legally obligated to pay as "pollution loss" caused by a "pollution condition" to which this insurance applies, provided:

- (1) The "pollution condition" arises out of "your work"; and
- (2) The "bodily injury" or "property damage" occurs, or "cleanup costs" are incurred, during the policy period.

With respect to "bodily injury", "property damage", or "cleanup costs" caused by legionella, there must be a direct relation to a documented case of a legionella outbreak for coverage to apply.

##### b. Transportation Pollution Liability

We will pay on behalf of the insured those sums in excess of the Pollution Liability Self-Insured Retention shown in the Declarations that the insured becomes legally obligated to pay as "pollution loss" resulting from a "transportation pollution condition" to which this insurance applies, provided:

- (1) The "transportation pollution condition" arises out of "transported cargo" that is transported, delivered, or shipped by you in a "covered conveyance" or by a "carrier" on your behalf; and
- (2) The "bodily injury" or "property damage" occurs, or the "cleanup costs" are incurred, during the policy period.

This coverage shall not be utilized to evidence financial responsibility of any insured under any federal, state, provincial, or local law.

**c. Non-Owned Disposal Site Liability**

We will pay on behalf of the insured those sums in excess of the Pollution Liability Self-Insured Retention shown in the Declarations that the insured becomes legally obligated to pay as "pollution loss" resulting from a "pollution condition" at, on, or under a "non-owned disposal site"; provided:

- (1) Such "pollution condition" originates at a "non-owned disposal site";
- (2) The "pollution condition" arises from waste or material generated by "your work"; and
- (3) The "bodily injury" or "property damage" occurs, or the "cleanup costs" are incurred, during the policy period.

**d. Sudden And Accidental Discharge, Release, Or Escape Of Pollutants Liability**

We will pay on behalf of the insured those sums in excess of the Pollution Liability Self-Insured Retention shown in the Declarations that the insured becomes legally obligated to pay as "pollution loss" resulting from a sudden and accidental "pollution condition":

- (1) At, on, or under a Designated Location shown in the Declarations; or
- (2) Originating at and migrating from a Designated Location shown in the Declarations;

provided:

- (a) The "pollution condition" is the result of an unforeseen, unplanned, or unexpected event or circumstance;
- (b) The "pollution condition" commences during the policy period;
- (c) The "pollution condition" is first discovered by any insured no later than 7 days after it commences;
- (d) The insured reports the commencement of the "pollution condition" to us in writing no later than 21 days following its discovery by any insured; and
- (e) The "claim" is first made during the policy period.

**e. Crisis Management And Emergency Response Costs**

We will indemnify you for:

- (1) "Crisis management costs" you incur as a direct result of a "crisis management event", provided that the "crisis management event":
  - (a) Arises directly from a "pollution condition" that has resulted or is reasonably likely to result in a "pollution loss" covered under this policy;
  - (b) Commences during the policy period; and
  - (c) First becomes known to any "responsible insured" during the policy period and is reported to us in writing as soon as practicable, but in any event during the policy period or within 30 days after the end of the policy period.

We will pay those "crisis management costs" you incur even if coverage hereunder is still to be confirmed by us, but we will stop paying such "crisis management costs" as soon as it becomes evident, to either you or us, that this insurance does not apply. "Crisis management costs" are not subject to the Self-Insured Retention.

- (2) "Emergency response costs" you incur in excess of the Pollution Liability Self-Insured Retention shown in the Declarations as a direct result of a "pollution condition" that occurs in the "coverage territory" and has resulted in a "pollution loss" covered under this policy.

2. The following Insuring Agreements apply only if the "wrongful act" takes place in the "coverage territory". The amount we will pay is limited as described in Section IV - Limits Of Insurance And Self-Insured Retention.

**a. Professional Liability**

- (1) We will pay on behalf of the insured those sums in excess of the Professional Liability Self-Insured Retention shown in the Declarations that the insured becomes legally obligated to pay as "professional loss".
- (2) This insurance applies to "professional loss" only if:
- (a) The "wrongful act" takes place on or after the Professional Liability Retroactive Date, if any, shown in the Declarations and before the end of the policy period; and
- (b) A "claim" is first made against any insured during the policy period and reported to us during the policy period or the Extended Reporting Period, if applicable.

**b. Professional Liability Rectification Expense**

Upon the Named Insured's submission to us of satisfactory written proof of payment, we will reimburse the Named Insured for "rectification expense" incurred in excess of the Professional Liability Rectification Expense Self-Insured Retention shown in the Declarations with respect to any action to rectify or mitigate an actual, negligent act, error, or omission that would otherwise lead to a "claim" covered under this policy, provided that:

- (1) The act, error, or omission giving rise to the "rectification expense" happens on or after the Professional Liability Rectification Expense Retroactive Date shown in the Declarations;
- (2) The insured must provide us notice of the act, error, or omission and any proposed corrective action in writing as soon as practicable but in any event during the policy period or the Extended Reporting Period, if applicable; and
- (3) All "rectification expenses" must be approved by us prior to being incurred by the insured.

If we and the insured do not agree that the insured's proposed rectification action is reasonable, we and the insured may agree to submit such dispute to any form of alternative dispute resolution acceptable to both parties. Should we and the insured be unable to agree on the form of alternative dispute resolution, then such dispute will be submitted to binding arbitration administered by the American Arbitration Association under its Commercial Arbitration rules, and judgment on the award rendered by the arbitrators may be entered in any court having jurisdiction.

**B. Claims And Defense**

1. Solely with respect to Insuring Agreements **A.1.a.** Contractors Pollution Liability (Including Mold And Legionella), **A.1.b.** Transportation Pollution Liability, and **A.1.C.** Non-owned Disposal Site Liability under Section I - Coverages, coverage applies only if, prior to the policy period, no "responsible insured" knew that the "bodily injury", "property damage", or "cleanup costs" had occurred, in whole or in part. If any "responsible insured" knew, prior to the policy period, that the "bodily injury", "property damage", or "cleanup costs" occurred, then any continuation, change, or resumption of such "bodily injury", "property damage", or "cleanup costs" during or after the policy period will be deemed to have been known prior to the policy period.

"Bodily injury", "property damage", or "cleanup costs" which occur during the policy period and were not, prior to the policy period, known to have occurred by any "responsible insured", includes any continuation, change, or resumption of the "bodily injury", "property damage", or "cleanup costs" after the end of the policy period.

"Bodily injury", "property damage", or "cleanup costs" will be deemed to have been known to have occurred at the earliest time when any "responsible insured":

- a. Reports all or any part of the "bodily injury", "property damage", or "cleanup costs" to us or any other insurer;
- b. Receives a written or verbal demand or "claim" for "loss" because of the "bodily injury", "property damage", or "cleanup costs"; or
- c. Becomes aware by any other means that the "bodily injury", "property damage", or "cleanup costs" have occurred or have begun to occur.

"Loss" because of "bodily injury" includes damages claimed by any person or organization for care, loss of services, or death resulting at any time from the "bodily injury".

2. Solely with respect to the Insuring Agreement **2.a. Professional Liability**, a "claim" by a person or organization seeking "loss" directly arising out of a "wrongful act" will be deemed to have been made at the earlier of when notice of such "claim" is received by any insured or by us.

All "claims" for "loss" arising out of the same, related, or continuous "wrongful act" will be considered a single "claim", and will be deemed to have been made and reported at the time the first of those "claims" is made against any insured.

Any reported "wrongful act" that subsequently becomes a "claim" made against the insured and reported to us in writing will be deemed to have been first made on the date that the written notice of the "wrongful act" was first reported to us and will be subject to all of the terms and conditions of this policy.

3. We will:

- a. Have the right to investigate any "claim"; and
- b. Have the right and duty to defend the insured against any "suit";

for "loss" to which this insurance applies.

However, we will have no duty to defend the insured against any "claim" seeking "loss" to which this insurance does not apply. We may, at our discretion, investigate any "pollution condition" or "wrongful act" and settle any "claim" that may result. But:

- (1) The amount we will pay for "loss" is limited as described in Section **IV - Limits Of Insurance And Self-Insured Retention**; and
- (2) Our right and duty to defend ends when we have used up the applicable limit of insurance in the payment of judgments, settlements, or supplementary payments.

## **C. Supplementary Payments**

### **1. Loss Of Earnings And Expense Reimbursement**

We will pay, with respect to any "claim" we investigate or settle, or any "suit" against an insured we defend:

- a. All expenses we incur.
- b. All reasonable expenses incurred by the insured at our request to assist us in the investigation or defense of the "claim", including actual loss of earnings up to \$5,000 a day because of time off from work.
- c. All court costs taxed against the insured in the "suit". However, these payments do not include attorneys' fees or attorneys' expenses taxed against the insured.
- d. Pre-judgment interest awarded against the insured on that part of the judgment we pay. If we make an offer to pay the applicable limit of insurance, we will not pay any pre-judgment interest based on that period of time after the offer.
- e. All interest on the full amount of any judgment that accrues after entry of the judgment and before we have paid, offered to pay, or deposited in court the part of the judgment that is within the applicable limit of insurance.

Amounts paid under this Loss Of Earnings And Expense Reimbursement Supplementary Payment will reduce the Defense Expenses Aggregate Limit shown in the Declarations. Once that limit has been exhausted, amounts paid under this Supplementary Payment will reduce the applicable Limits Of Insurance shown in the Declarations.

### **2. Suit Against Indemnitee**

If we defend an insured against a "suit" and an indemnitee of the insured is also named as a party to the "suit", we will defend that indemnitee if all of the following conditions are met:

- a. The "suit" against the indemnitee seeks "loss" for which the insured has assumed the liability of the indemnitee in a contract or agreement that is an "insured contract";
- b. This insurance applies to such liability assumed by the insured;
- c. The obligation to defend, or the cost of the defense of, that indemnitee has also been assumed by the insured in the same "insured contract";

- d. The allegations in the "suit" and the information we know about the "pollution condition" or "wrongful act" are such that no conflict appears to exist between the interests of the insured and the interests of the indemnitee;
- e. The indemnitee and the insured ask us to conduct and control the defense of that indemnitee against such "suit" and agree that we can assign the same counsel to defend the insured and the indemnitee; and
- f. The indemnitee:
  - (1) Agrees in writing to:
    - (a) Cooperate with us in the investigation, settlement, or defense of the "suit";
    - (b) Immediately send us copies of any demands, notices, summonses, or legal papers received in connection with the "suit";
    - (c) Notify any other insurer whose coverage is available to the indemnitee; and
    - (d) Cooperate with us with respect to coordinating other applicable insurance available to the indemnitee; and
  - (2) Provides us with written authorization to:
    - (a) Obtain records and other information related to the "suit"; and
    - (b) Conduct and control the defense of the indemnitee in such "suit".

As long as the above conditions are met, attorneys' fees incurred by us in the defense of that indemnitee, necessary litigation expenses incurred by us, and necessary litigation expenses incurred by the indemnitee at our request will be paid as supplementary payments.

We may, at our option, appoint one counsel to defend all of the insureds and indemnitees of the insureds who are or may be involved with respect to such "suit".

Our obligation to defend an insured's indemnitee and to pay for attorneys' fees and necessary litigation expenses as supplementary payments ends when we have used up the applicable limit of insurance in the payment of judgments, settlements, or supplementary payments, or the conditions or the terms of the agreement set forth above are no longer met.

Amounts paid under this Suit Against Indemnity Supplementary Payment will reduce the Defense Expenses Aggregate Limit shown in the Declarations. Once that limit has been exhausted, amounts paid under this Supplementary Payment will reduce the Limits Of Insurance shown in the Declarations.

### **3. Pre-Claim Investigation Expenses**

- a. If, during the policy period, the insured first becomes aware of a specific "wrongful act" that is reasonably expected to result in a "claim" within the scope of this coverage, then the insured may elect to provide notice of a potential "claim" to us. Such notice to us shall be in writing, sent to us at the address shown in the claim reporting policyholder notice, and contain the following information:
  - (1) The description of the specific "wrongful act";
  - (2) The date on which such "wrongful act" took place;
  - (3) The damage which has or may result from such "wrongful act";
  - (4) The identity of any injured person or organization subject to such injury or damage; and
  - (5) The date and circumstances by which the insured first became aware of such "wrongful act".
- b. If such written notice is received by us during the policy period, we may, at our sole option, choose to investigate the "wrongful act". Such an investigation will be at our expense and will not reduce the Limits Of Insurance or be subject to the Self-Insured Retention provisions until one of the following occurs:
  - (1) A "claim" results from the "wrongful act" under investigation; or
  - (2) We incur the Pre-Claim Investigation Expenses Limit shown in the Declarations in expenses arising from the investigation.
- c. If a "claim" is made and reported to us, or once we incur the Pre-Claim Investigation Expenses Limit shown in the Declarations, any further payment will be considered "claims expense" and will reduce the applicable Limits Of Insurance and be subject to the Self-Insured Retention provisions of this insurance.



Any "claim" subsequently made against the "insured" arising out of such "wrongful act" will be deemed to have been first made on the date on which such written notice is first received by the company.

No coverage for pre-claim investigation expenses is provided by this Policy except as provided by this Paragraph C.3. Pre-Claim Investigation Expenses of Section I - Coverages.

#### **D. Coverage Extensions**

Although various Coverage Extensions are referenced in this policy, a Coverage Extension is included within this policy only if that Coverage Extension is designated as purchased by an "X" in the Declarations.

##### **1. Disciplinary Proceeding Legal Expense Reimbursement**

a. Upon the Named Insured's submission to us of satisfactory written proof of payment, we will reimburse the Named Insured for all reasonable and necessary legal fees and legal expenses incurred in response to a "disciplinary proceeding" against the Named Insured first initiated during the policy period or the Extended Reporting Period, if applicable, provided:

(1) The "wrongful act" giving rise to the "disciplinary proceeding" happens during the policy period and on or after the Professional Liability Retroactive Date shown in the Declarations; and

(2) Prior to the effective date of the first date of continuous coverage for this Coverage Extension with us, no "responsible insured" knew that such "wrongful act" had occurred, or any fact, circumstance, situation, or incident which would lead a reasonable person in the insured's position to conclude that a "claim" was likely.

b. The most we will reimburse the Named Insured under this Coverage Extension for legal fees or legal expenses as the result of any one "disciplinary proceeding" is the Each Disciplinary Proceeding Limit shown in the Declarations.

The most we will reimburse the Named Insured under this Coverage Extension for the sum of legal fees and legal expenses as the result of all "disciplinary proceeding" is the Aggregate Disciplinary Proceeding Limit shown in the Declarations.

The remaining legal fees or legal expenses are the sole responsibility of the Named Insured and do not reduce the Professional Liability Self-Insured Retention shown in the Declarations.

c. The Named Insured must provide to us written notice as soon as practicable of any "disciplinary proceeding" first initiated against the Named Insured during the policy period or the Extended Reporting Period, if applicable. In any event, such "disciplinary proceeding" must be reported to us no later than 60 days after the end of the policy period or the Extended Reporting Period, if applicable.

d. No reimbursement will be made for the Named Insured's payment of any taxes; criminal or civil fines, penalties, or sanctions; registration or licensing fees; or any monetary judgment, award, or settlement of any kind.

##### **2. Subpoena Assistance**

In the event that during the policy period:

a. The insured first receives a subpoena or a written request for the insured's records or files or notice of deposition relative to a "pollution condition" or a "wrongful act" in the performance of "your work"; and

b. The insured reports the receipt of such subpoena or written request to us within 30 days of such receipt and prior to a "claim" being first made against the insured arising out of such "pollution condition" or "wrongful act";

then we will pay on behalf of the insured up to the Subpoena Assistance Limit shown in the Declarations per policy period for reasonable and necessary legal fees and expenses incurred for engaging the services of legal counsel we select to assist the insured in responding to such subpoena or request.

Payments under these Coverage Extensions will be in addition to the General Aggregate Limit shown in the Declarations and not subject to the Self-Insured Retention.

#### **SECTION II - EXCLUSIONS**

A. With respect to all Insuring Agreements, Supplementary Payments, and Coverage Extensions, this insurance does not apply to:

##### **1. Contractual Liability**

"Loss" the insured is legally obligated to pay as damages as a result of the assumption of liability in a contract or agreement. However, this exclusion does not apply to liability:

- a. That the insured would have in the absence of the contract or agreement; or
- b. Solely with respect to coverage provided under Insuring Agreement **1.**, assumed in a contract or agreement that is an "insured contract", provided the "loss" occurs subsequent to the execution of the contract or agreement.

## **2. Fines, Penalties, And Punitive Damages**

Any punitive damages, exemplary damages, multiplied damages, fines, or penalties. However, this exclusion does not apply to punitive or exemplary damages where insurable by law.

## **3. Damage To Property**

"Property damage" in any way related to any real property or facility that is or was at any time owned, operated, or occupied by, or rented to you. However, this exclusion does not apply:

- a. If the real property or facility is operated or occupied by you for the purpose of performing "your work"; or
- b. To coverage provided under Insuring Agreements **A.1.d.** Sudden And Accidental Discharge, Release, Or Escape Of Pollutants Liability or **A.2.b.** Professional Liability Rectification Expense, if shown as purchased on the Declarations.

## **4. Damage To Your Product Or Your Work**

"Property damage" to "your product" or "your work" or any part of "your product" or "your work". This exclusion does not apply:

- a. If the damaged work or the work out of which the damage arises was performed on your behalf by a subcontractor; or
- b. To coverage provided under Insuring Agreement **A.2.b.** Professional Liability Rectification Expense, if shown as purchased in the Declarations.

## **5. Employer's Liability**

"Bodily injury" to:

- a. An "employee" of the insured arising out of and in the course of:
  - (1) Employment by the insured; or
  - (2) Performing duties related to the conduct of the insured's business; or
- b. The spouse, child, parent, brother, or sister of that "employee" as a consequence of such "bodily injury".

This exclusion applies whether the insured may be liable as an employer or in any other capacity and to any obligation to share damages with or repay someone else who must pay damages because of the injury. However, this exclusion does not apply to liability assumed by the insured under an "insured contract".

## **6. Expected Or Intended Injury**

"Bodily injury" or "property damage" expected or intended from the standpoint of any "responsible insured".

## **7. Impaired Property**

"Property damage" to "impaired property" or property that has not been physically injured, arising out of:

- a. A defect, deficiency, inadequacy, or dangerous condition in "your product" or "your work"; or
- b. A delay or failure by you or anyone acting on your behalf to perform a contract or agreement in accordance with its terms.

This exclusion does not apply to:

- (1) The loss of use of other property arising out of sudden and accidental physical injury to "your product" or "your work" after it has been put to its intended use; or
- (2) "Rectification expense" to the extent coverage is provided under Section I - Coverages, Paragraph **A.** Insuring Agreements, **2.b.** Professional Liability Rectification Expense.

## 8. Insured Versus Insured

Any "claim" made by or on behalf of an insured against any other insured. However, solely with respect to coverage provided under Insuring Agreement 1., this exclusion does not apply with respect to "claims" against you by any insured seeking coverage or indemnification pursuant to a written contract or agreement for a "claim" otherwise covered for "bodily injury", "property damage", or "cleanup costs".

## 9. Intentional Acts

"Loss" arising out of intentional, willful, or deliberate:

- a. Injury to persons or property; or
- b. Failure to comply with any permit, administrative complaint, notice of violation, notice letter, executive order, or instruction of any governmental or public agency or body.

However, this exclusion does not apply to:

- (1) An insured who did not commit, participate in, or have knowledge of any of the acts described above; or
- (2) "Claim expenses" incurred until an allegation is determined through final and non-appealable adjudication.

## 10. Known Circumstances Or Conditions

"Loss" caused by, arising out of, or in any way involving:

- a. A "pollution condition", including any subsequent continuation or resumption of or changes in such "pollution condition", that existed prior to the policy period and was known to any "responsible insured" at any time before the beginning of the policy period;
- b. A fact, event, circumstance, or condition known by any "responsible insured" prior to the inception date of this policy where any "responsible insured" should have reasonably foreseen that such fact, event, circumstance, or condition could give rise to a "claim" under this policy; or
- c. The rendering of or failure to render "professional services" prior to the inception date of this policy, if any "responsible insured" knew or should have reasonably foreseen that such rendering of or failure to render "professional services" could give rise to a "claim" under this policy.

## 11. Nuclear Energy Liability

"Loss":

- a. With respect to which an insured under this policy is also an insured under a nuclear energy liability policy issued by the Nuclear Energy Liability Insurance Association, Mutual Atomic Energy Liability Underwriters, Nuclear Insurance Association of Canada, or any of their successors, or would be an insured under any such policy but for its termination upon exhaustion of its limit of insurance;
- b. Resulting from the "hazardous properties" of "nuclear material" and with respect to which:
  - (1) Any person or organization is required to maintain financial protection pursuant to the Atomic Energy Act of 1954, or any law amendatory thereof; or
  - (2) The insured is, or had this policy not been issued would be, entitled to indemnity from the United States of America, or any agency thereof, under any agreement entered into by the United States of America, or any agency thereof, with any person or organization; or
- c. Resulting from the "hazardous properties" of "nuclear material", if:
  - (1) The "nuclear material":
    - (a) Is at any "nuclear facility" owned by or operated by or on behalf of an insured; or
    - (b) Has been discharged or dispersed therefrom;
  - (2) The "nuclear material" is contained in "spent fuel" or "waste" at any time possessed, handled, used, processed, stored, transported, or disposed of by or on behalf of an insured; or
  - (3) The "loss" arises out of the furnishing by an insured of services, materials, parts, or equipment in connection with the planning, construction, maintenance, operation, or use of any "nuclear facility", but if

such facility is located within the United States of America, its territories or possessions or Canada, this exclusion (3) applies only to "property damage" to such "nuclear facility" and any property thereat.

As used in this exclusion:

"Hazardous properties" includes radioactive, toxic, or explosive properties.

"Nuclear facility" means:

- a. Any "nuclear reactor";
- b. Any equipment or device designed or used for:
  - (1) Separating the isotopes of uranium or plutonium;
  - (2) Processing or utilizing "spent fuel"; or
  - (3) Handling, processing, or packaging "waste";
- c. Any equipment or device used for the processing, fabricating, or alloying of "special nuclear material" if at any time the total amount of such material in the custody of the insured at the premises where such equipment or device is located consists of or contains more than 25 grams of plutonium or uranium 233 or any combination thereof, or more than 250 grams of uranium 235;
- d. Any structure, basin, excavation, premises, or place prepared or used for the storage or disposal of "waste"; and includes the site on which any of the foregoing is located, all operations conducted on such site and all premises used for such operations.

"Nuclear material" means "source material", "special nuclear material", or "by-product material".

"Nuclear reactor" means any apparatus designed or used to sustain nuclear fission in a self-supporting chain reaction or to contain a critical mass of fissionable material.

"Property damage" includes all forms of radioactive contamination of property.

"Source material", "special nuclear material", and "by-product material" have the meanings given them in the Atomic Energy Act of 1954 or in any law amendatory thereof.

"Spent fuel" means any fuel element or fuel component, solid or liquid, which has been used or exposed to radiation in a "nuclear reactor".

"Waste" means any waste material:

- a. Containing "by-product material" other than the tailings or wastes produced by the extraction or concentration of uranium or thorium from any ore processed primarily for its "source material" content; and
- b. Resulting from the operation by any person or organization of any "nuclear facility" included under the first two paragraphs of the definition of "nuclear facility".

## **12. Other Enterprises**

"Loss" arising out of any business enterprise owned, operated, or managed by the insured or its parent company or any affiliate, successor, or assignee of such company not named in the Declarations. However, this exclusion does not apply to any person or organization who has controlling interest over you with respect to their liability arising out of their financial control over you or premises they own, maintain, or control while you lease or occupy such premises.

## **13. Professional Services**

"Loss" arising out of any "wrongful act". This exclusion applies even if the "claim" against any insured alleges negligence or other wrongdoing in the supervision, hiring, employment, training, or monitoring of others by that insured.

However, this exclusion does not apply to:

- a. A "claim" in which you committed a "wrongful act" relating to improper or inadequate supervision, direction, or control of any subcontractors for which you are legally liable when such subcontractors are performing operations on your behalf at a job site; or

- b. Coverage provided under Insuring Agreements **A.2.a.** Professional Liability or **A.2.b.** Professional Liability Rectification Expense, if shown as purchased in the Declarations.

#### **14. Property Damage To Cargo**

"Property damage" to "transported cargo".

#### **15. Property Damage To Conveyances**

"Property damage" to any "auto", railcar, train, watercraft, or aircraft operated by or on behalf of any insured resulting from a "pollution condition" caused by "transported cargo". However, this exclusion does not apply to any "claim" brought by any "carrier" for "property damage" arising out of the insured's negligence.

#### **16. Vehicles**

"Loss" arising out of the ownership, maintenance, use, operation, or entrustment to others of any aircraft, "unmanned aircraft", "auto", or watercraft. Use includes "loading or unloading", but does not include the movement of property by means of a mechanical device, other than a hand truck, that is not attached to the aircraft, "unmanned aircraft", "auto", or watercraft.

However, this exclusion does not apply to:

- a. "Loading or unloading" within the boundaries of any location covered by this policy;
- b. "Bodily injury" or "property damage" arising out of:

- (1) The delivery of any liquid product into a wrong receptacle or to a wrong address; or
- (2) The erroneous delivery of one liquid product for another by an "auto";

if the "bodily injury" or "property damage" occurs after such operations have been completed or abandoned at the site of such delivery.

Operations which may require further service, maintenance, correction, repair, or replacement of performance at the wrong address or because of any error, defect, or deficiency, but which are otherwise completed, will be deemed completed; or

- c. Coverage provided under Insuring Agreement **A.1.b.** Transportation Pollution Liability, if shown as purchased in the Declarations.

#### **17. War**

"Loss", however caused, arising, directly or indirectly, out of:

- a. War, including undeclared or civil war;
- b. Warlike action by a military force, including action taken in the hindering or defending against an actual or expected attack, by any government, sovereign, or other authority using military personnel or other agents; or
- c. Insurrection, rebellion, revolution, usurped power, or action taken by governmental authority in hindering or defending against any of these.

#### **18. Workers' Compensation And Similar Laws**

Any obligation of any insured under workers' compensation, disability benefits, unemployment compensation law, or any similar law.

#### **19. Your Products**

"Loss" arising out of "your product":

- a. Designed, manufactured, sold, handled, distributed, altered, or repaired by you or by others trading under your name, any failure to warn, or any reliance upon a representation or warranty made at any time with respect thereto; or
- b. Fabricated or installed by you, unless a "pollution condition" arises from the fabrication or installation of "your products" as part of "your work".

- B.** With respect to Insuring Agreement **A.2.**, Supplementary Coverages, and Coverage Extensions, this insurance does not apply to:

##### **1. Breach Of Contract**

"Claims" in any way involving an actual or alleged breach of contract, including, but not limited to, a breach of a written, express, oral, implied-in-law, or implied-in-fact contract.

## **2. Employment Practices**

"Claims" arising out of the employment relationship or the nature, terms, or conditions of employment or any workplace tort brought by or on behalf of any "employee", former "employee", prospective "employee", independent contractor, or consultant of the insured including, but not limited to, the following:

- a. Refusal to employ that person;
- b. Termination of that person's employment; or
- c. Employment-related practices, policies, acts, or omissions, such as coercion, demotion, evaluation, reassignment, discipline, defamation, harassment, humiliation, discrimination, or malicious prosecution directed at that person.

## **3. Executive Officer**

"Claims" arising out of your services or capacity as an executive officer, director, partner, trustee, or employee of a business enterprise not named in the Declarations.

## **4. Express Warranties**

"Claims" arising out of any express warranties or guarantees.

## **5. Financial Related Matters**

"Claims" arising out of any:

- a. Liability or breach of any duty or obligation owed by you:
  - (1) In connection with the operation or administration of any health, pension, or employee benefit scheme, plan, trust, or fund, including but not limited to, violation or alleged violation of any related legislation or regulation such as the Employee Retirement Income Security Act of 1974, as amended; or
  - (2) Regarding the sale or purchase of any stocks, shares, or other securities, or the misuse of any information relating to them, including breach or alleged breach of any related legislation or regulation, including but not limited to the Securities Act of 1933 and Securities Exchange Act of 1934, both as amended; or
- b. Breach of any fiduciary duty owed by you.

## **6. Insurance Or Bonds**

"Claims" arising out of the advising of, requiring of, or failure to advise of or require, or failure to obtain or maintain, any form of insurance or surety bond.

## **7. Intellectual Property Hazard**

"Claims" in any way involving any "intellectual property hazard", or any non-disclosure, non-compete, or non-solicitation agreement.

## **8. Knowingly Wrongful Acts**

"Claims" arising out of any dishonest, fraudulent, criminal, malicious, intentional, or illegal "wrongful act" or knowingly "wrongful act" of any "responsible insured".

## **9. Not Licensed As Required By Law**

"Claims" arising out of any acts or services performed by any insured that is not licensed or certified to perform such acts or services if such licensing or certification is required by law.

## **10. Patents Or Trade Secrets**

"Claims" arising out of any:

- a. Infringement or inducement of infringement of patent or trade secret or misappropriation of trade secrets or confidential or proprietary information relating to the Named Insured's business operations;
- b. Unfair competition based upon infringement of copyright, patent, trademark, service mark, trade name, or trade secret;

- c. The value of trade secrets, confidential processing methods, or other confidential or proprietary information;  
or
- d. Any dispute related to ownership of any intellectual property.

#### 11. Prior Claims

"Claims" first made against you prior to the inception of this coverage.

#### 12. Prior Notice

"Claims" arising out of any fact, circumstance, or situation that has been the subject of any notice given prior to the policy period under any other policy of insurance or to any reinsurer, risk retention group or captive (or any other self-insurance plan or trust by whatsoever name), or insurance representative.

### SECTION III - WHO IS AN INSURED

#### A. Each of the following is an insured under all Insuring Agreements, Supplementary Payments, and Coverage Extensions:

##### 1. If you are designated in the Declarations as:

- a. An individual, you and your spouse or "domestic partner" are insureds, but only with respect to the conduct of a business of which you are the sole owner.
- b. A partnership or joint venture, you are an insured. Your members, your partners, and their spouse or "domestic partner" are also insureds, but only with respect to the conduct of your business.
- c. A limited liability company, you are an insured. Your members are also insureds, but only with respect to the conduct of your business. Your managers are insureds, but only with respect to their duties as your managers.
- d. A corporation or an organization other than a partnership, joint venture, or limited liability company, you are an insured. Your "executive officers" and directors are insureds, but only with respect to their duties as your officers or directors. Your stockholders are also insureds, but only with respect to their liability as stockholders.

##### 2. Any subsidiary company of yours and any company over which you have active control or majority ownership interest, or exercise management or financial control is a Named Insured with respect to the conduct of your business, provided:

- a. You report all such entities to us within 180 days after you have acquired the organization; and
- b. There is no other similar primary insurance available to that organization, unless such entity has been specifically endorsed onto this policy.

However:

(1) Coverage is afforded only until the 180<sup>th</sup> day after you acquire the subsidiary or the end of the policy period, whichever is earlier; and

(2) Coverage does not apply to "loss" that first commences before you acquired the subsidiary.

##### 3. Your "employees", other than either your "executive officers" (if you are a corporation or an organization other than a partnership, joint venture, or limited liability company) or your managers (if you are a limited liability company), but only for acts within the scope of their employment by you or while performing duties related to the conduct of "your work".

##### 4. In the event of your bankruptcy, your trustees, and in the event of your death or incapacity, your legal representatives or executors, but only with respect to each such trustee's, representative's, or executor's vicarious liability resulting from "your work".

##### 5. Any organization you newly form, including any partnership, joint venture, or limited liability company, and over which you maintain ownership or majority interest, will qualify as an insured, if:

- a. You have contractually agreed to provide insurance for such organization;
- b. There is no other similar primary insurance available to that organization, unless such entity has been specifically endorsed onto this policy; and

c. You report to us within 180 days after such formation that you acquired or formed the organization.

However:

- (1) Coverage is afforded only until the 180<sup>th</sup> day after you form the organization or the end of the policy period, whichever is earlier; and
- (2) Coverage does not apply to "loss" that first commences before you formed the organization.

B. Solely with respect to coverage provided under Insuring Agreements **A.1.a.** through **A.1.e.** and Supplementary Payments, each of the following is also an insured:

1. Any person or organization who has controlling interest over you, but only with respect to their liability arising out of their financial control over you or premises they own, maintain, or control while you lease or occupy those premises.
2. Any:
  - a. Person or organization with whom the insured has agreed to provide additional insured status in a written contract or agreement executed prior to the "pollution loss", but only with respect to liability for "pollution loss" arising out of "your work"; and
  - b. Other person or organization you are required to add as an additional insured under the written contract or agreement described in Paragraph **a.** above.

However, any insurance afforded to such additional insured:

- (1) Only applies to the extent permitted by law;
- (2) Will not be broader than that which you are required by the contract or agreement to provide for such insured; and
- (3) Is limited to the lesser of the applicable Limits Of Insurance shown in the Declarations or the amount required by the written contract or agreement. This Paragraph **2.** does not apply to any person or organization specifically named as an additional insured in an endorsement attached to this policy.

#### **SECTION IV - LIMITS OF INSURANCE AND SELF-INSURED RETENTION**

##### **A. Limits Of Insurance**

1. The Limits Of Insurance shown in the Declarations and the rules below fix the most we will pay regardless of the number of insureds, "claims" made, or persons or organizations making "claims".
2. The General Aggregate Limit shown in the Declarations is the most we will pay for the sum of all "loss" and supplementary payments arising out of all "pollution conditions" and "wrongful acts" under all Insuring Agreements.
3. Subject to the General Aggregate Limit shown in the Declarations:
  - a. The Each Contractor's Pollution Condition Limit shown in the Declarations is the most we will pay under Insuring Agreement **A.1.a.** Contractor's Pollution Liability (Including Mold And Legionella) for the sum of all "pollution loss" and supplementary payments arising out of any one "pollution condition".
  - b. The Each Transportation Pollution Condition Limit shown in the Declarations is the most we will pay under Insuring Agreement **A.1.b.** Transportation Pollution Liability for the sum of all "pollution loss" and supplementary payments arising out of any one "transportation pollution condition".
  - c. The Each Non-Owned Disposal Site Pollution Condition Limit shown in the Declarations is the most we will pay under Insuring Agreement **A.1.C.** Non-Owned Disposal Site Liability for the sum of all "pollution loss" and supplementary payments arising out of any one "pollution condition" at a "non-owned disposal site".
  - d. The Each Sudden And Accidental Pollution Condition Limit shown in the Declarations is the most we will pay under Insuring Agreement **A.1.d.** Sudden And Accidental Discharge, Release, Or Escape Of Pollutants Liability for the sum of all "pollution loss" and supplementary payments arising out of any one "pollution condition".
  - e. The Each Crisis Management And Emergency Response Limit shown in the Declarations is the most we will pay under Insuring Agreement **A.1.e.** Crisis Management And Emergency Response Costs for the sum of all "crisis management costs " and "emergency response costs" arising out of any one "pollution condition".



- f. The Each Wrongful Act Limit shown in the Declarations is the most we will pay under Insuring Agreement **A.2.a.** Professional Liability for the sum of all "professional loss" and supplementary payments arising out of any one "wrongful act".
- g. The Each Professional Liability Rectification Expense Limit shown in the Declarations is the most we will pay under Insuring Agreement **A.2.b.** Professional Liability Rectification Expense for the sum of all "rectification expenses" arising out of any one "wrongful act". The remaining "rectification expenses" will be the sole responsibility of the Named Insured and do not reduce the Professional Liability Rectification Expense Self-Insured Retention shown in the Declarations.

In the event a "claim" arises out of the same reported "wrongful act" for which the insured incurred "rectification expense", the limit available for payment of the "claim" will be the Each Wrongful Act Limit shown in the Declarations excess of the Professional Liability Rectification Expense Self-Insured Retention, minus the amount we reimbursed the insured for "rectification expense" under Insuring Agreement **A.2.b.** Professional Liability Rectification Expense, subject to the General Aggregate Limit shown in the Declarations.

- 4. Amounts paid under Supplementary Payments **C.1.** Loss Of Earnings And Expense Reimbursement and **C.2.** Suit Against Indemnitee will reduce the Defense Expenses Aggregate Limit shown in the Declarations. Once that limit has been exhausted, amounts paid as supplementary payments will reduce the applicable limits described in Paragraphs **2.** and **3.** above.

The limits of insurance of this policy apply separately to each policy period, unless the policy period is extended after issuance for an additional period. In that case, the additional period will be deemed part of the last preceding period for purposes of determining the limits of insurance.

## **B. Self-Insured Retention**

- 1. You agree to assume the:
  - a. Pollution Liability Self-Insured Retention shown in the Declarations with respect to the Insuring Agreements under Section **A.1.**;
  - b. Professional Liability Self-Insured Retention shown in the Declarations with respect to Insuring Agreement **A.2.a.**; and
  - c. Professional Liability Rectification Expense Self-Insured Retention shown in the Declarations with respect to Insuring Agreement **A.2.b.**

Our obligation to pay "loss" or supplementary payments under this insurance and the applicable limit of insurance shown in the Declarations will apply in excess of the applicable Self-Insured Retention.

- 2. Regardless of whether or not there is any other insurance, whether or not collectible, applicable to a "claim", "pollution condition", or "wrongful act" within the Self-Insured Retention, you must make actual payment of the full Self-Insured Retention before the limits of insurance will apply. Compliance with this clause is a condition precedent for coverage under this insurance. We will make no payments of any type in the event you fail to comply with this clause.
- 3. You must not incur costs other than adjusting expenses without our written consent in the event of any "claim", "pollution condition", or "wrongful act" which appears likely to exceed the applicable Self-Insured Retention.
- 4. We have the right in all cases to assume control of the investigation, defense, and settlement of any "claim", "pollution condition", or "wrongful act" to which this insurance applies. When we exercise this right, the following apply:
  - a. You will remain responsible for the cost of all "loss" and supplementary payments within the applicable Self-Insured Retention;
  - b. At our request, you will advance to us any portion of the applicable Self-Insured Retention that we deem reasonable to pay for any "claim", "pollution condition", or "wrongful act";
  - c. If you have paid to us all or part of the applicable Self-Insured Retention and the total amount of the "loss" and supplementary payments that we pay for that "claim", "pollution condition", or "wrongful act" is less than the applicable Self-Insured Retention, then we will reimburse you the amount you paid in excess of the amount we pay; and

- d. We will have the sole and absolute right to settle the "claim" for any amount we deem reasonable, including any amount within the Self-Insured Retention. Although we agree to attempt to advise and consult with you prior to making any settlement, we will have no obligation to obtain your consent or the consent of any other insured to any settlement we make that requires payment from you of any amount within the Self-Insured Retention. You and any other insured hereby waive any claim or defense against us resulting from our entering into any such settlement without your approval.

**C. Multiple Insureds, Claims, And Claimants**

The inclusion herein of more than one insured in any "claim" or the making of "claims" by more than one person or organization will not operate to increase the Limits Of Insurance shown in the Declarations. More than one "claim" arising out of a single "pollution condition" or "wrongful act" will be treated as a single "claim". Such single "claim" will be deemed first made on the date on which the earliest "claim" arising out of such "pollution condition" or "wrongful act" is made or, with respect to written notice given to and accepted by us, on the date within the policy period on which such written notice of potential "claim" is first received by us.

**SECTION V - EXTENDED REPORTING PERIOD**

For the applicable claims-made coverages, the following applies:

- A.** We will provide one or more Extended Reporting Periods, as described below, if:

- 1. Claims-made coverage provided by this policy is canceled or not renewed; or
- 2. We renew or replace the claims-made coverage provided by this policy with insurance that:
  - a. Has a Retroactive Date later than the date shown in the Declarations; or
  - b. Does not apply to "professional services" coverage on a claims-made basis.

The quotation of a different premium, deductible, or limit of insurance for renewal does not constitute a cancellation or refusal to renew for the purpose of this provision.

- B.** The Extended Reporting Periods do not extend the policy period or change the scope of coverage provided. They apply only to injury from acts, errors, or omissions that occur before the end of the policy period but not before the applicable Retroactive Date shown in the Declarations, provided a "claim" for such injury is first made during the Extended Reporting Period.

Once in effect, the Extended Reporting Period may not be canceled.

- C.** A Basic Extended Reporting Period is automatically provided without additional charge. This period starts with the end of the policy period and lasts for 60 days.

The Basic Extended Reporting Period does not apply to "claims" that are covered under any subsequent insurance you purchase, or that would be covered but for exhaustion of the amount of insurance applicable to such "claims".

- D.** An Optional Extended Reporting Period is available, subject to Paragraph **E.** below, but only by an endorsement and for an extra charge. This Optional Extended Reporting Period starts when the Basic Extended Reporting Period, set forth in Paragraph C. above, ends.

You must give us a written request for the endorsement within 60 days after the end of the policy period. The Optional Extended Reporting Period will not go into effect unless you pay the additional premium promptly when due.

We will determine the additional premium in accordance with our rules and rates. In doing so, we may take into account the following:

- 1. The exposures insured;
- 2. Previous types and amounts of insurance;
- 3. Limits of insurance available under this policy for future payment of "professional loss"; and
- 4. Other related factors.

This endorsement will set forth the terms, not inconsistent with this section, applicable to the Optional Extended Reporting Period, including a provision to the effect that the insurance afforded for "claims" first received during such period is excess over any other valid and collectible insurance available under policies in force after the Optional Extended Reporting Period starts.

- E.** We do not have to provide an Optional Extended Reporting Period if:

1. There is any failure to pay any outstanding premiums when due;
  2. Any insured fails to repay any self-insured retention amount we have paid;
  3. Any insured has purchased any other insurance to replace the insurance provided under this endorsement; or
  4. The application for this policy, including any addenda thereto, contains any material misrepresentation of fact.
- F. The Extended Reporting Period will not reinstate or in any way increase the Limits Of Insurance shown in the Declarations.

## **SECTION VI - CONDITIONS**

### **A. Assignment**

This insurance may not be assigned without our prior consent, which consent will not be unreasonably withheld or delayed. Assignment of interest under this insurance will not bind us until our consent has been endorsed hereon.

### **B. Bankruptcy**

Bankruptcy or insolvency of the insured or the insured's estate will not relieve us of our obligations or increase our liability under this policy.

### **C. Cancellation Or Nonrenewal**

1. This policy may be canceled by you by surrender thereof to us or any of our authorized representatives or by mailing to us written notice stating when thereafter the cancellation will be effective.
2. If we decide to cancel or not to renew this policy, we will mail or deliver to the first Named Insured shown in the Declarations written notice of cancellation or nonrenewal not less than:
  - a. 10 days prior to cancellation if we cancel for non-payment of premium;
  - b. 90 days prior to cancellation if we cancel for material misrepresentation or material change in risk covered by this policy; or
  - c. 60 days prior to nonrenewal.
3. If we cancel this policy for a reason listed in Paragraph **b.(2)** above, we will provide written notice of cancellation to any person or organization who has been issued a certificate of insurance under this policy stating when, not less than 90 days from the date of such notice, cancellation will become effective, but only if:
  - a. Cancellation is for reasons other than nonpayment of premium or self-insured retention reimbursement;
  - b. You are required by written contract to provide the additional insured with such notice; and
  - c. You provide us with a list of the applicable additional insureds, including their complete mailing addresses, within 7 days of our request.
4. If notice is mailed, proof of mailing is sufficient proof of such notice.

### **D. Changes**

This policy contains all the agreements between you and us concerning the insurance afforded. The first Named Insured shown in the Declarations will act on behalf of all insureds for the receipt and acceptance of any endorsement issued by us to form a part of this policy. This policy's terms and conditions can be amended or waived only by endorsement issued by us and made a part of this policy. Notice to any agent or knowledge possessed by any agent or by any other person will not effect a waiver or change in any part of this policy or estop us from asserting any right under the terms and conditions of this policy.

### **E. Choice Of Law**

Unless otherwise expressly endorsed in this policy, the laws of New York, without giving effect to its conflicts of law principles, governs all matters arising out of or relating to this policy and all of the transactions it contemplates including, without limitation, its formation, validity, interpretation, construction, performance, and enforcement.

### **F. Currency Provision**

The limits of insurance, self-insured retention amount, and premiums shown in this policy are in United States currency. Any payments by us or you will be in United States currency.

### **G. Duties In The Event Of A Pollution Condition, Claim, Or Wrongful Act**

1. You must see to it that we are notified as soon as practicable in writing of a "pollution condition" or "wrongful act". To the extent possible, notice must contain:
  - a. How, when, and where the "pollution condition" or "wrongful act" took place;
  - b. The names and addresses of any claimants, injured persons, and witnesses;
  - c. The nature and location of any injury or damage arising out of the "pollution condition" or "wrongful act";
  - d. The date and details of "your work" that may have caused the "pollution condition" or "wrongful act";
  - e. Copies of any contracts that have been entered into by any insured that are related to "your work" performed or "professional services" rendered; and
  - f. Details explaining how the insured first became aware of the "pollution condition" or "wrongful act".
2. Any reported "wrongful act" that subsequently becomes a "claim" made against the insured and reported to us in writing will be deemed to have been first made on the date that the written notice of the "wrongful act" was first received by us and will be subject to all of the terms and conditions of this policy.
3. If a "claim" is made against any insured:
  - a. You must record and notify us as soon as practicable in writing of the specifics of the "claim" and the date received; and
  - b. You and any other involved insured must:
    - (1) Send us copies as soon as practicable of any demands, notices, summons, or legal papers received in connection with the "claim";
    - (2) Authorize us to obtain records and other information;
    - (3) Cooperate with us in the investigation, settlement, or defense of the "claim"; and
    - (4) Assist us, upon our request, in the enforcement of any right against any person or organization which may be liable to the insured because of injury or damage to which this insurance may also apply.
4. No insured will, except at that insured's own cost, voluntarily make a payment, assume any obligation, or incur any expense without our written consent. However, written consent is not required with respect to:
  - a. "Crisis management costs" that have been reported in accordance with Insuring Agreement **A.1.e.** Crisis Management Or Emergency Response Costs; or
  - b. "Emergency response costs" that have been reported and approved by us or our appointed representative by use of the emergency response hotline.
5. Notice to your insurance agent or broker does not constitute notice to us for purposes of the receipt of notice.

#### **H. Inspections And Surveys**

1. We have the right to:
  - a. Make inspections and surveys at any time;
  - b. Give you reports on the conditions we find; and
  - c. Recommend changes.
2. We are not obligated to make any inspections, surveys, reports, or recommendations, and any such actions we do undertake relate only to insurability and the premiums to be charged. We do not make safety inspections. We do not undertake to perform the duty of any person or organization to provide for the health or safety of workers or the public. And we do not warrant that conditions:
  - a. Are safe or healthful; or
  - b. Comply with laws, regulations, codes, or standards.
3. Paragraphs **a.** and **b.** of this condition apply not only to us but also to any rating, advisory, rate service, or similar organization which makes insurance inspections, surveys, reports, or recommendations.

4. Paragraph **b.** of this condition does not apply to any inspections, surveys, reports, or recommendations we may make relative to certification, under state or municipal statutes, ordinances, or regulations, of boilers, pressure vessels, or elevators.

#### **I. Legal Action Against Us**

No person or organization has a right under this policy:

1. To join us as a party or otherwise bring us into a "suit" asking for damages from an insured; or
2. To sue us on this policy unless all of its terms have been fully complied with.

A person or organization may sue us to recover on an agreed settlement or on a final judgment against an insured obtained after an actual trial; but we will not be liable for "losses" that are not payable under the terms of this policy or that are in excess of the applicable limit of insurance. An agreed settlement means a settlement and release of liability signed by us, the insured, and the claimant or the claimant's legal representative.

#### **J. No Duplication Of Coverage**

Only one Insuring Agreement will apply to the same "pollution condition". In the event that more than one Insuring Agreement can apply to the same "pollution condition", then the only Insuring Agreement that will apply will be that Insuring Agreement under which we have accepted coverage or that Insuring Agreement that has been held to apply to such "pollution condition".

However, this condition does not apply to Insuring Agreement **A.1.e.** Crisis Management And Emergency Response Costs.

#### **K. Other Insurance**

If other valid and collectible insurance is available to the insured for "loss" we cover under this policy, our obligations are limited as follows:

##### **1. Primary Insurance**

This insurance is primary except when Paragraph **b.** below applies. If this insurance is primary, our obligations are not affected unless any of the other insurance is also primary. In that case, we will share with all such other insurance by the method described in Paragraph **c.** below.

##### **2. Excess Insurance**

**a.** This insurance is excess over:

- (1) Any other insurance, whether primary, excess, contingent, or on any other basis, if you are an insured on an insurance policy that applies to "your work" performed at a specific job site and that insurance policy applies to a specific job site;
- (2) Any other valid and collectible insurance available to you covering liability for "loss" arising out of "your work" or "professional services", including that work or "professional services" for which you have been added as an additional insured by an endorsement, by definition in a contract or agreement, or by combination thereof; or
- (3) Any other valid and collectible insurance available to any person or entity performing functions for others on your behalf as defined in "your work" or "professional services" in this policy.

**b.** When this insurance is excess, we will have no duty to defend the insured against any "suit" if any other insurer has a duty to defend the insured against that "suit". If no other insurer defends, we will undertake to do so, but we will be entitled to the insured's rights against all those other insurers.

**c.** When this insurance is excess over other insurance, we will pay only our share of the amount of the "loss", if any, that exceeds the sum of:

- (1) The total amount that all such other insurance would pay for the damages in the absence of this insurance; and
- (2) The total of all deductible and self-insured amounts under all that other insurance.

We will share the remaining "loss", if any, with any other insurance that is not described in this Excess Insurance provision and was not bought specifically to apply in excess of the Limits Of Insurance shown in the Declarations of this policy.

### **3. Method Of Sharing**

If all of the other insurance permits contribution by equal shares, we will follow this method also. Under this approach each insurer contributes equal amounts until it has paid its applicable limit of insurance or none of the "loss" remains, whichever comes first.

If any of the other insurance does not permit contribution by equal shares, we will contribute by limits. Under this method, each insurer's share is based on the ratio of its applicable limit of insurance to the total applicable limits of insurance of all insurers.

### **4. Primary And Non-Contributory Insurance**

Regardless of Paragraphs 1. through 3. above, this insurance is primary to, and will not seek contribution from:

- a. Any other insurance available to any additional insured with whom you agree in a written contract or agreement to provide insurance on a primary and non-contributory basis;
- b. Any other insurance available to any additional insured specifically named in an endorsement attached to this policy as an additional insured on a primary and non-contributory basis; or
- c. Other valid and collectible insurance available, with respect to a "claim" covered under Insuring Agreement **A.1.b.** Transportation Pollution Liability.

### **L. Premium Audit**

1. We will compute all premiums for this policy in accordance with our rules, rates, rating plans, and minimum premium requirements.
2. Premium shown as Advance And Deposit Premium in the Declarations is a deposit premium only. At the close of each audit period, we will compute earned premium for that period. All audit premiums are due and payable on notice to the first Named Insured.
3. The first Named Insured must keep records of the information we need for premium computation and send us copies at such times as we may request.

### **M. Premiums**

The first Named Insured shown in the Declarations is responsible for the payment of all premiums and will be the payee for any return premiums we pay.

### **N. Representations**

By accepting this policy, you agree:

1. The statements in the applications, other materials submitted to us, and Declarations are accurate and complete;
2. Those statements are based upon representations you made to us; and
3. We have issued this policy in reliance upon your representations.

### **O. Separation Of Insureds**

Except with respect to the limits of insurance, and any rights or duties specifically assigned to the first Named Insured shown in the Declarations, this insurance applies:

1. As if each Named Insured were the only Named Insured; and
2. Separately to each insured against whom a "claim" is made.

### **P. Transfer Of Rights Of Recovery Against Others To Us**

If the insured has rights to recover all or part of any payment we have made under this insurance, those rights are transferred to us. The insured must do nothing after "loss" to impair our rights. At our request, the insured will bring "suit" or transfer those rights to us and help us enforce them.

However, we waive any right of recovery we may have against any person or organization with whom the insured has agreed in a written contract or agreement to provide a waiver of transfer of rights of recovery because of payments we make for injury or damage arising out of your ongoing operations or "your work" done under a written contract with that person or organization. But this waiver does not apply to any person or organization specifically named in an endorsement attached to this policy which waives our rights of subrogation and recovery.

## **Q. Transfer Of Your Rights And Duties Under This Policy**

Your rights and duties under this policy may not be transferred without our prior written consent except in the case of death of an individual Named Insured. If you die, your rights and duties will be transferred to your legal representative, but only while acting within the scope of duties as your legal representative. Until your legal representative is appointed, anyone having proper temporary custody of your property will have your rights and duties but only with respect to that property.

## **R. Waiver Of Self-Insured Retention Upon Successful Mediation**

The self-insured retention will be waived, up to a maximum of \$10,000, if:

1. A "claim" has not entered into litigation;
2. We and you mutually agree to "mediation" as a means to settle a "claim" made against the insured; and
3. Such "claim" is settled as a direct result of the "mediation" and within 30 days of the end of the "mediation".

When this occurs, we will not seek reimbursement from you for any qualifying self-insured retention amount we pay prior to the "mediation".

## **SECTION VII - DEFINITIONS**

- A.** "Auto" means a land motor vehicle, trailer, or semitrailer designed for travel on public roads, including any attached machinery or equipment.
- B.** "Bodily injury" means physical injury, sickness, disease, mental anguish, or emotional distress sustained by any person, including medical monitoring, loss of services, or death resulting from any of these at any time.
- C.** "Cargo" means waste, products, or materials carried or delivered by a "covered conveyance".
- D.** "Carrier" means a person or an entity, other than any insured or any subsidiary or affiliate company of any insured, engaged by the insured to transport material by aircraft, "auto", or watercraft, but only if such person or entity is properly licensed to transport such material and in the business of transporting such material.
- E.** "Claim" means the insured's or our receipt of:
1. A written demand for "loss"; or
  2. The service of "suit" or institution of arbitration proceedings against the insured.

However, "claim" does not include any "disciplinary proceeding".

- F.** "Cleanup costs" means reasonable and necessary expenses incurred in the investigation, evaluation, monitoring, testing, removal, containment, treatment, disposal, remediation, detoxification, or neutralization of, or response to any "pollutants":
1. To the extent required by federal, state, local, or provincial laws, including, but not limited to, statutes, rules, ordinances, guidance documents, regulations, and all amendments thereto, including state voluntary cleanup or risk-based corrective action guidance, governing the liability or responsibilities of the insured; or
  2. Which have been actually incurred by the government or any political subdivision of the United States of America or any state thereof, or by third parties.

"Cleanup costs" includes "restoration costs".

- G.** "Completed operations" means "your work" that has been completed. "Completed operations" does not include "your work" that has been abandoned or has not yet been completed. "Your work" will be deemed completed at the earliest of the following times:
1. When all work to be performed under the contract has been completed;
  2. When all of the work to be done at the site has been completed if the contract calls for work at more than one site; or
  3. When that part of the work done at a job site has been put to its intended use by any person or organization other than another contractor or subcontractor working on the same project. "Your work" that may require further service, maintenance, correction, repair, or replacement, but is otherwise complete, will be deemed completed.

- H.** "Coverage territory" means:

1. The United States of America and its territories or possessions; and
  2. International waters or airspace, but only if the "loss" occurs in the course of travel or transportation between any places included in Paragraph 1. above.
- I. "Covered conveyance" means any conveyance operated by or on behalf of an insured used for transporting property.
- J. "Crisis management consultant" means a professional firm or consultant that provides crisis management services and has been approved in writing by us, the approval for which will not be unreasonably withheld.
- K. "Crisis management costs" means those reasonable and necessary fees and expenses:
1. Incurred by you within 90 days after the "crisis management event" is discovered by you and is thereafter approved by us in writing; and
  2. For services provided to you by a "crisis management consultant" for the sole purpose of assisting you with:
    - (a) Managing the media in direct response to a "crisis management event" to which this insurance applies; or
    - (b) Minimizing the economic harm to you caused by a "crisis management event" to which this insurance applies by consulting with you with respect to maintaining and restoring your company's public image or reputation.

You must take reasonable steps to minimize "crisis management costs".

- L. "Crisis management event" means the public announcement by a third party that a "pollution condition" for which you are legally responsible has caused:
1. "Bodily injury" involving third parties; or
  2. "Property damage", but only to the extent resulting in actual physical damage to real property owned by third parties;

provided that one of your "executive officers" has proffered, at our sole discretion, a good faith opinion that the public announcement or accusation has caused or is reasonably likely to cause economic harm to, or a material adverse effect on, your company's image or goodwill.

- M. "Disciplinary proceeding" means the insured's receipt of any proceeding by a United States of America domiciled regulatory body, disciplinary board, or governmental agency, any of which has the authority to investigate charges of professional misconduct in the performance of "professional services"; however, "disciplinary proceedings" will not include any criminal proceeding.
- N. "Domestic partner" means any natural person qualifying as a domestic partner under the provisions of any applicable federal, state, or local law.
- O. "Emergency response costs" means reasonable and necessary costs incurred to mitigate a "pollution condition" constituting an emergency situation under applicable law whereby in the absence of such mitigation:
1. "Bodily injury" or "property damage" to third parties is imminent; or
  2. "Cleanup costs" pursuant to environmental law are incurred.
- P. "Employee" includes temporary and leased staff working on your behalf and under your direct supervision, but only with respect to "your work".
- Q. "Executive officer" means a person holding any of the officer positions created by your charter, constitution, by-laws, or any other similar governing document.
- R. "Impaired property" means tangible property, other than "your product" or "your work", that cannot be used or is less useful because:
1. It incorporates "your product" or "your work" that is known or thought to be defective, deficient, inadequate, or dangerous; or
  2. You have failed to fulfill the terms of a contract or agreement;
- if such property can be restored to use by the repair, replacement, adjustment, or removal of "your product" or "your work" or your fulfilling the terms of the contract or agreement.

- S. "Insured contract" means:



1. An obligation, as required by ordinance, to indemnify a municipality, except in connection with work for a municipality; or
  2. That part of any other contract or agreement pertaining to your business (including an indemnification of a municipality in connection with work performed for a municipality) under which you assume the tort liability of another party to pay for "bodily injury" or "property damage" to a third person or organization. Tort liability means a liability that would be imposed by law in the absence of any contract or agreement.
- T.** "Intellectual property hazard" means:
1. Infringement, in any manner, of a copyright, patent, trademark, service mark, trade dress, title or slogan, service name, trade name, or copyright joint ownership, or other intellectual property rights;
  2. Oral or written publication, in any manner, of material that slanders or libels a person or organization or disparages a person's or organization's goods, products, services, or claims;
  3. Piracy or unfair competition;
  4. Oral or written publication, in any manner, of material that violates a person's right to privacy;
  5. The use of another's style of doing business, intellectual property, trade secrets, or market share agreements;
  6. The use of another's advertising idea in your advertisement;
  7. Violations of the Lanham Act (15 USC §1051-1141N); and
  8. Violations of the Computer Fraud and Abuse Act (CFAA) (18 USC §1030), including violations of any regulations implementing the CFAA, and any similar state or federal law or regulation.
- U.** "Interrelated wrongful acts" means any "wrongful acts" that have as a common connection or nexus any fact, circumstance, situation, event, cause, transaction, or series of facts, circumstances, situations, events, causes, or transactions.
- V.** "Loading or unloading" means the handling of property:
- a. After it is moved from the place where it is accepted for movement into or onto a vehicle;
  - b. While it is in or on a vehicle; or
  - c. While it is being moved from a vehicle to the place where it is finally delivered.
- W.** "Loss" means "pollution loss" or "professional loss".
- X.** "Mediation" means the voluntary process in which an objective third party, who is a qualified professional mediator selected by the parties to the "claim" with our written agreement, intervenes between the parties to promote settlement of a "claim". "Mediation" does not include litigation, arbitration, or court mandated proceeding.
- Y.** "Mold" means any permanent or transient fungus, mold, mildew, or mycotoxin or any of the spores, scents, or by-products produced or released by fungus.
- Z.** "Natural resource damages" means physical injury to or destruction of, as well as the assessment of such injury or destruction, including the resulting loss of value of land, fish, wildlife, biota, air, water, groundwater, drinking water supplies, and other such resources belonging to, managed by, held in trust by, appertaining to, or otherwise controlled by the United States of America, any state or local government, any Native American tribe, or, if such resources are subject to a trust restriction on alienation, any member of a Native American tribe.
- AA.** "Non-owned disposal site" means a location you use for the treatment, storage, or disposal of waste or material, provided the "non-owned disposal site":
1. Is not managed, operated, owned, or leased by any insured or any subsidiary or affiliate of any insured;
  2. Is permitted or licensed by the applicable federal, state, local, or provincial authorities to accept such waste or material as of the date the waste or material is treated, stored, or disposed of at the "non-owned disposal site"; and
  3. Is not listed on a proposed or final Federal National Priorities List or any state or provincial equivalent National Priorities List, Superfund, or Hazardous Waste List prior to the treatment, storage, or disposal of the waste or material at the "non-owned disposal site".

**BB.** "Pollutants" means any solid, liquid, gaseous, thermal, biological, or low-level radioactive substance, material, or matter, irritant, or contaminant, including, but not limited to, electromagnetic frequency, smoke, vapor, soot, silt, sedimentation, fumes, acids, alkalis, chemicals, or waste. Waste includes medical waste and all other materials to be disposed of, recycled, stored, reconditioned, or reclaimed. With respect to Insuring Agreements **A.1.a.** Contractors Pollution Liability (Including Mold And Legionella) and **A.1.e.** Crisis Management And Emergency Response Costs only, "pollutants" includes "mold" and legionella pneumophila.

**CC.** "Pollution condition" means the discharge, dispersal, seepage, migration, growth, release, or escape of "pollutants". With respect to Insuring Agreements **A.1.b.** Transportation Pollution Liability and **A.1.e.** Crisis Management And Emergency Response Costs only, "pollution condition" includes "transportation pollution condition".

**DD.** "Pollution loss" means:

1. A monetary judgment, award, or settlement for "bodily injury" or "property damage"; or
2. "Cleanup costs".

**EE.** "Professional loss" means a monetary judgment, award, or settlement for a "wrongful act", including punitive or exemplary damages where insurable by law; however, "professional loss" does not include:

1. Multiplied portions of damages in excess of actual damages, including trebling of damages;
2. Any cost required to repair, build, or modify property to comply with any award or order by a court, administrative order, arbitration award, or any similar judgment;
3. Taxes, fines, or penalties imposed by law;
4. Sanctions;
5. Matters which are uninsurable under the law pursuant to which this policy will be construed;
6. The return, restitution, disgorgement, or off-set of any fees, costs, or expenses paid to or charged by any insured or any interest thereon;
7. Any other equitable relief;
8. Claimants' attorneys' fees or damages awarded for breach of contract, except attorneys' fees awarded for the successful prosecution of a "claim" otherwise covered by this policy; or
9. Any "rectification expense".

**FF.** "Professional services" means those functions as disclosed on the application or which are specifically shown in an endorsement to this policy performed for others by you or on your behalf that are related to your practice as a consultant, engineer, architect, surveyor, laboratory, project manager, or construction manager including, but not limited to, engineering services or the preparation or approval of maps, drawings, opinions, reports, surveys, designs, or specifications.

**GG.** "Property damage" means:

1. Physical injury to tangible property, including all resulting loss of use or diminution in value of that property. All such loss of use or diminution in value will be deemed to occur at the time of the physical injury that caused it;
2. Loss of use or diminution in value of tangible property that is not physically injured. All such loss of use or diminution in value will be deemed to occur at the time of the "claim"; or
3. "Natural resource damages".

**HH.** "Rectification Expense" means reasonable and necessary direct costs and expense incurred by the insured with respect to any action to rectify or mitigate a covered "wrongful act".

"Rectification expense" does not include any of the insured's profit, overhead, or mark-up, or any betterment to a project to which "rectification expense" applies.

**II.** "Responsible insured" means:

1. You, your "executive officer", director, partner, member, or manager;
2. Any insured who has responsibility, in whole or in part, for risk control, risk management, health and safety, or environmental affairs, control, or compliance; or

3. Any insured who signed or who has responsibility, in whole or in part, for completing the application on which we relied in issuing this policy.

**JJ.** "Restoration costs" means reasonable and necessary costs incurred by the insured with our consent, which will not be unreasonably withheld or delayed, to restore, repair, or replace real or personal property to substantially the same condition it was in prior to being damaged during work performed in the course of incurring "cleanup costs". However, such "restoration costs" will not exceed the actual cash value of such property immediately prior to incurring "cleanup costs" or include costs associated with improvements, betterments, ordinance, or law.

**KK.** "Suit" means a civil proceeding in which "loss" to which this insurance applies is alleged. "Suit" includes:

1. An arbitration proceeding in which such "loss" is claimed and to which the insured must submit or does submit with our consent; or
2. Any other alternative dispute resolution proceeding in which such "loss" is claimed and to which the insured submits with our consent.

"Suit" does not include any "disciplinary proceeding".

**LL.** "Transportation pollution condition" means the emission, discharge, dispersal, release, or escape of "pollutants" from a "covered conveyance" which occurs beyond the boundaries of a premises owned or occupied by, or rented or leased to, any insured.

**MM.** "Transported cargo" means the insured's "cargo" after it is moved from the place where it is accepted by or on behalf of an insured for movement into or onto a "covered conveyance", until the "cargo" is moved from the "covered conveyance" to the place where it is finally delivered on behalf of the insured. "Transported cargo" also includes "cargo" during "loading or unloading" to or from a "covered conveyance".

"Transported cargo" does not include "cargo" at rest for a period longer than 72 hours after it has been accepted on behalf of the insured for movement into or onto a "covered conveyance" but before it reaches the place of final delivery.

**NN.** "Unmanned aircraft" means an aircraft that is not designed, manufactured, or modified after manufacture to be controlled directly by a person from within or on the aircraft.

**OO.** "Wrongful act" means any actual or alleged act, error, or omission in the performance of "professional services" by you or any person for whose acts you are legally responsible.

"Wrongful act" includes "interrelated wrongful acts".

**PP.** "Your product":

1. Means:

(a) Any goods or products, other than real property, manufactured, sold, handled, distributed, or disposed of by:

(1) You;

(2) Others trading under your name; or

(3) A person or organization whose business or assets you have acquired; and

(b) Containers (other than vehicles), materials, parts, or equipment furnished in connection with such goods or products.

2. Includes:

(a) Warranties or representations made at any time with respect to the fitness, quality, durability, performance, or use of "your product"; and

(b) The providing of or failure to provide warnings or instructions.

3. Does not include vending machines or other property rented to or located for the use of others but not sold.

**QQ.** "Your work":

1. Means:

(a) Contracting work or contracting operations performed by you or on your behalf for others at a location that you do not own, control, rent, or occupy other than for the purpose of performing "your work"; and

**(b)** Materials, parts, or equipment furnished in connection with such work or operations.

**2.** Includes:

**(a)** Warranties or representations made at any time with respect to the fitness, quality, durability, performance, or use of "your work";

**(b)** The providing of or failure to provide warnings or instructions; and

**(c)** The "completed operations" of "your work".

ORP 2021-0716	Base Year			2nd Opt year			3rd Opt year		
	Valid from 11/1/2021 through 10/31/2022			Valid from 11/1/2023 through 10/31/2024			Valid from 11/1/2024 through 10/31/2025		
Description	Unit Type	Est Qty	Bid Unit Price	Unit Type	Est Qty	Bid Unit Price	Unit Type	Est Qty	Bid Unit Price
Set up/mobilization cost (outage only)	each: <u>\$7,800</u>	2	\$15,600.00	each: <u>\$7,800</u>	2	\$15,600.00	each: <u>\$8,900</u>	2	\$17,800.00
Demobilization cost (outage only)	each: <u>\$6,000</u>	2	\$1,200.00	each: <u>\$6,000</u>	2	\$12,000.00	each: <u>\$6,850</u>	2	\$13,700.00
Millwright-Journeyman (Straight Time Rate)	Hour	1-100+	\$117.00	Hour	1-100+	\$129.75	Hour	1-100+	\$135.00
Millwright-Journeyman (1.5-time rate)	Hour	1-100+	\$171.00	Hour	1-100+	\$188.25	Hour	1-100+	\$197.00
Millwright-Journeyman (2-time rate)	Hour	1-100+	\$227.00	Hour	1-100+	\$250.00	Hour	1-100+	\$260.00
Millwright-Foreman (Straight Time Rate)	Hour	1-100+	\$117.00	Hour	1-100+	\$129.75	Hour	1-100+	\$135.00
Millwright-Foreman (1.5-time rate)	Hour	1-100	\$171.00	Hour	1-100	\$188.25	Hour	1-100	\$197.00
Millwright-Foreman (2-time rate)	Hour	1-100	\$227.00	Hour	1-100	\$250.00	Hour	1-100	\$260.00
Heavy Equipment Operator (Straight Time Rate)	Hour	1-100	\$85.01	Hour	1-100	\$104.00	Hour	1-100	\$107.00
Heavy Equipment Operator (1.5-time rate)	Hour	1-100	\$125.01	Hour	1-100	\$150.50	Hour	1-100	\$157.00
Heavy Equipment Operator (2-time rate)	Hour	1-100	\$164.01	Hour	1-100	\$199.50	Hour	1-100	\$207.00
Heavy Equipment Operator- Foreman (Straight Time Rate)	Hour	1-100	\$85.01	Hour	1-100	\$104.00	Hour	1-100	\$107.00
Heavy Equipment Operator- Foreman (1.5-time rate)	Hour	1-100	\$125.01	Hour	1-100	\$150.50	Hour	1-100	\$157.00
Heavy Equipment Operator – Foreman (2-time rate)	Hour	1-100	\$164.01	Hour	1-100	\$199.50	Hour	1-100	\$207.00
Crane Operator-Journeyman (Straight Time Rate)	Hour	1-100	\$85.01	Hour	1-100	\$104.00	Hour	1-100	\$107.00
Crane Operator-Journeyman (1.5-time rate)	Hour	1-100	\$125.01	Hour	1-100	\$150.50	Hour	1-100	\$157.00
Crane Operator-Journeyman (2-time rate)	Hour	1-100	\$164.01	Hour	1-100	\$199.50	Hour	1-100	\$207.00
Laborer-Journeyman (Straight Time Rate)	Hour	1-100	\$74.75	Hour	1-100	\$85.50	Hour	1-100	\$89.00
Laborer-Journeyman (1.5-time rate)	Hour	1-100	\$109.75	Hour	1-100	\$124.00	Hour	1-100	\$131.00
Laborer-Journeyman (2-time rate)	Hour	1-100	\$143.75	Hour	1-100	\$165.00	Hour	1-100	\$172.00
Management Supervisor (Straight Time Rate)	Hour	1-100	\$117.00	Hour	1-100	\$129.75	Hour	1-100	\$135.00
Management Supervisor (1.5 time rate)	Hour	1-100	\$171.00	Hour	1-100	\$188.25	Hour	1-100	\$197.00
Management Supervisor (2-time rate)	Hour	1-100	\$227.00	Hour	1-100	\$250.00	Hour	1-100	\$260.00
Shop Labor-Fabricator/Machinist (Straight Time Rate)	Hour	1-100	\$70.00	Hour	1-100	\$75.00	Hour	1-100	\$80.00
Shop Labor-Fabricator/Machinist (1.5 time rate)	Hour	1-100	\$70.00	Hour	1-100	\$107.50	Hour	1-100	\$114.00
Crane Operator-Journeyman (Straight Time Rate)	Hour	1-100	\$85.01	Hour	1-100	\$104.00	Hour	1-100	\$107.00
Crane Operator-Journeyman (1.5-time rate)	Hour	1-100	\$125.01	Hour	1-100	\$150.50	Hour	1-100	\$157.00
Crane Operator-Journeyman (2-time rate)	Hour	1-100	\$164.01	Hour	1-100	\$199.50	Hour	1-100	\$207.00

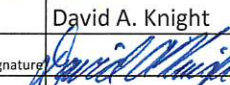
Scissors Lift-at least 26-foot working height	Day	1-100	\$56.00	Day	1-100	\$95.00	Day	1-100	\$95.00
	Week		\$126.00	Week		\$270.00	Week		\$270.00
Pick-up Truck-1/2 ton	Day	1-100	\$72.00	Day	1-100	\$105.00	Day	1-100	\$105.00
	Week		\$277.00	Week		\$420.00	Week		\$420.00
Pick-up Truck-3/4 ton	Day	1-100	\$72.00	Day	1-100	\$105.00	Day	1-100	\$105.00
	Week		\$277.00	Week		\$420.00	Week		\$420.00
Forklift-5,000 Lb.	Day	1-100	\$171.00	Day	1-100	\$225.00	Day	1-100	\$225.00
	Week		\$512.00	Week		\$780.00	Week		\$780.00
Welder-250 Amp	Day	1-100	\$66.00	Day	1-100	\$85.00	Day	1-100	\$85.00
	Week		\$252.00	Week		\$375.00	Week		\$375.00
Welder-300 XMT Amp	Day	1-100	\$66.00	Day	1-100	\$85.00	Day	1-100	\$85.00
	Week		\$252.00	Week		\$375.00	Week		\$375.00
Cargo Tool Trailer/ Office	Day	1-100	\$80.00	Day	1-100	\$110.00	Day	1-100	\$110.00
	Week		\$320.00	Week		\$440.00	Week		\$440.00
Manlift 40'w/Knuckle boom	Day	1-100	\$132.00	Day	1-100	\$250.00	Day	1-100	\$250.00
	Week		\$315.00	Week		\$725.00	Week		\$725.00
Manlift 80'	Day	1-100	\$776.00	Day	1-100	\$910.00	Day	1-100	\$910.00
	Week		\$2,300.00	Week		\$2,800.00	Week		\$2,800.00
Scissor lift	Day	1-100	\$56.00	Day	1-100	\$95.00	Day	1-100	\$95.00
	Week		\$126.00	Week		\$270.00	Week		\$270.00
Carry deck crane	Day	1-100	\$179.00	Day	1-100	\$625.00	Day	1-100	\$625.00
	Week		\$680.00	Week		\$1,700.00	Week		\$1,700.00
20-ton crane	Day	1-100	\$600.00	Day	1-100	\$1,300.00	Day	1-100	\$1,300.00
	Week		\$2,400.00	Week		\$3,900.00	Week		\$3,900.00
80-ton crane	Day	1-100	\$1,323.00	Day	1-100	\$1,750.00	Day	1-100	\$1,750.00
	Week		\$5,040.00	Week		\$5,000.00	Week		\$5,000.00
All terrain forklift	Day	1-100	\$231.00	Day	1-100	\$250.00	Day	1-100	\$250.00
	Week		\$624.00	Week		\$650.00	Week		\$650.00
% Markup for Sub contractors/ Parts /materials			15%			15%			15%
Knight Const. & Supply		Base Year Pricing was per Knight's response to PW ITB 5506-21		David A. Knight					
Dave Knight dave@knightconst.com				Signature			Signature		
Ryan Reed ryan@knightconst.com				Date	8-15-2024		Date		
509 276 2229									



**Agenda Sheet for City Council:**

**Committee:** PIES **Date:** 10/21/2024

**Committee Agenda type:** Consent

**Date Rec'd** 10/22/2024

**Clerk's File #** OPR 2024-0927

**Cross Ref #**

**Project #**

**Council Meeting Date:** 11/04/2024

<b>Submitting Dept</b>	SOLID WASTE DISPOSAL	<b>Bid #</b>	RFQ 6237-24
------------------------	----------------------	--------------	-------------

<b>Contact Name/Phone</b>	DAVID PAINE 625-6878	<b>Requisition #</b>	CR 26786
---------------------------	----------------------	----------------------	----------

<b>Contact E-Mail</b>	DPAINE@SPOKANECITY.ORG		
-----------------------	------------------------	--	--

<b>Agenda Item Type</b>	Contract Item		
-------------------------	---------------	--	--

<b>Council Sponsor(s)</b>	BWILKERSON JBINGLE KKLITZKE		
---------------------------	-----------------------------	--	--

<b>Agenda Item Name</b>	4490-CONTRACT FOR TRANSPORTATION OF TOPSOIL FOR THE NORTHSIDE		
-------------------------	---	--	--

**Agenda Wording**

Contract award 1 of 2 from RFQ 6237-24 to Action Materials (Spokane, WA) for the transportation of topsoil to the Northside Landfill from 11/15/2024-11/14/2025 and a total cost not to exceed \$65,000.00 plus tax.

**Summary (Background)**

The City's Landfill requires topsoil to use as ground cover for the active cell. American Recycling has a large amount of soil that can be used for this purpose. It would be obtained at no cost but Solid Waste Disposal would need to haul the soil. RFQ 6237-24 was issued for this service and three responses were received. The contract will be awarded to the two lowest-bidders; Action Materials and Circle M Landscaping. This will allow soil to be hauled as-needed without scheduling conflicts.

Lease? NO Grant related? NO Public Works? NO

**Fiscal Impact**

Approved in Current Year Budget? YES

Total Cost	\$ \$65,000.00
------------	----------------

Current Year Cost	\$ 0
-------------------	------

Subsequent Year(s) Cost	\$ 0
-------------------------	------

**Narrative**

This is an operating supply/contractual services expense that was planned for in the Solid Waste Disposal budget. This was awarded to two bidders, but overall spend between both contracts is anticipated to be no more than \$65,000.00.

**Amount**

**Budget Account**

Expense	\$ 65,000.00	# 4530-44800-53748-54201
---------	--------------	--------------------------

Select	\$	#
--------	----	---

Select	\$	#
--------	----	---

Select	\$	#
--------	----	---

	\$	#
--	----	---

	\$	#
--	----	---





## Committee Agenda Sheet

### Public Infrastructure, Environment & Sustainability Committee

<b>Committee Date</b>	October 21, 2024
<b>Submitting Department</b>	Solid Waste Disposal
<b>Contact Name</b>	David Paine
<b>Contact Email &amp; Phone</b>	<a href="mailto:dpaine@spokanecity.org">dpaine@spokanecity.org</a> , 509-625-6878
<b>Council Sponsor(s)</b>	Wilkerson, Bingle, Klitzke
<b>Select Agenda Item Type</b>	<input checked="" type="checkbox"/> Consent <input type="checkbox"/> Discussion    Time Requested:
<b>Agenda Item Name</b>	Contract for transportation of topsoil for the Northside Landfill
<b>Proposed Council Action</b>	<input checked="" type="checkbox"/> Approval to proceed to Legislative Agenda <input type="checkbox"/> Information Only
<b>Summary (Background)</b>	<p>The City's Northside Landfill requires topsoil to use as ground cover for the active cell. American Recycling has a large amount of topsoil that needs removed from their facility that can be used for this purpose. The soil would be obtained at no cost but the Solid Waste Disposal department needs to facilitate the transportation of the soil.</p> <p>On September 25, 2024, bidding closed on RFQ 6237-24 for dump truck services for transportation of topsoil. Three responses were received. Due to scheduling needs of this project, the contract will be awarded to the two lowest bidders; Action Materials (Spokane, WA) and Circle M Construction &amp; Landscape Supplies, Inc. (Spokane Valley, WA). The contracts will begin on November 15, 2024 and run through November 14, 2025 with a total cost not to exceed \$65,000.00 plus applicable taxes.</p>
<b>Summary (Background)</b>	<p>*use the Fiscal Impact box below for relevant financial information</p>
<b>Fiscal Impact</b>	
<b>Approved in current year budget?</b> <input checked="" type="checkbox"/> Yes <input type="checkbox"/> No <input type="checkbox"/> N/A Total Cost: <u>\$65,000.00</u> Current year cost: \$65,000.00 Subsequent year(s) cost: 0	
<b>Narrative:</b> <u>This is an operating supplies expense that was planned for in the Solid Waste Disposal budget.</u>	
<b>Funding Source</b> <input type="checkbox"/> One-time <input checked="" type="checkbox"/> Recurring <input type="checkbox"/> N/A Specify funding source: Program revenue Is this funding source sustainable for future years, months, etc? Yes	
<b>Expense Occurrence</b> <input checked="" type="checkbox"/> One-time <input type="checkbox"/> Recurring <input type="checkbox"/> N/A  Other budget impacts: (revenue generating, match requirements, etc.)	
<b>Operations Impacts (If N/A, please give a brief description as to why)</b>	
<ul style="list-style-type: none"> <li>What impacts would the proposal have on historically excluded communities?            Public works services and projects are designed to serve all citizens and businesses. We strive to offer a consistent level of service to all, to distribute public investment throughout the community and to respond to gaps in services identified in various City plans.</li> </ul>	

- How will data be collected, analyzed, and reported concerning the effect of the program/policy by racial, ethnic, gender identity, national origin, income level, disability, sexual orientation, or other existing disparities?  
N/A
- How will data be collected regarding the effectiveness of this program, policy, or product to ensure it is the right solution?  
Public Works follows the City's established procurement and public works bidding regulations and policies to bring items forward, and then uses contract management best practices to ensure desired outcomes and regulatory compliance.
- Describe how this proposal aligns with current City Policies, including the Comprehensive Plan, Sustainability Action Plan, Capital Improvement Program, Neighborhood Master Plans, Council Resolutions, and others?  
This work is consistent with annual budget strategies to limit costs and approved projects in the 6-year CIP.

**Council Subcommittee Review**

- Please provide a summary of council subcommittee review. If not reviewed by a council subcommittee, please explain why not.

Not applicable



**City of Spokane**  
**PERSONAL SERVICES AGREEMENT**  
**Title: DUMP TRUCK SERVICES**

This Agreement is made and entered into by and between the **CITY OF SPOKANE** as (“City”), a Washington municipal corporation, and **ACTION MATERIALS, INC.**, whose address is 8579 West Westbow Blvd., Spokane, Washington 99224 as (“Company”), individually hereafter referenced as a “Party”, and together as the “Parties”.

*WHEREAS, the purpose of this Agreement is to provide Dump Truck Services for Transport of Topsoil for the Waste to Energy Facility; and*

*WHEREAS, the Company was selected through RFQ 6237-24 issued by the City.*

*NOW, THEREFORE, in consideration of the terms, conditions, covenants and performance of the Scope of Work contained herein, the City and Company mutually agree as follows:*

**1. TERM OF AGREEMENT.**

The term of this Agreement begins on November 15, 2024, and shall run through November 14, 2025, unless amended by written agreement or terminated earlier under the provisions. This Agreement may be extended by written agreement of the parties not to exceed two (2) additional one year contract renewal periods.

**2. TIME OF BEGINNING AND COMPLETION.**

The Company shall begin the work outlined in the “Scope of Work” (“Work”) on the beginning date, above. The City will acknowledge in writing when the Work is complete. Time limits established under this Agreement shall not be extended because of delays for which the Company is responsible, but may be extended by the City, in writing, for the City’s convenience or conditions beyond the Company’s control.

**3. SCOPE OF WORK.**

The General Scope of Work for this Agreement is described in Action Materials, Inc. - RFQ 6237-24 Bid Response Summary dated September 25, 2024, which is attached as **Exhibit B** and made a part of this Agreement. In the event of a conflict or discrepancy in the Agreement documents, this City Personal Services Agreement controls.

The Work is subject to City review and approval. The Company shall confer with the City periodically, and prepare and present information and materials (e.g. detailed outline of completed Work) requested by the City to determine the adequacy of the Work or Company’s progress.

**4. COMPENSATION / PAYMENT.**

Total compensation for Company’s services under this Agreement shall not exceed **SIXTY-FIVE**

**THOUSAND AND NO/100 DOLLARS (\$65,000.00)**, and applicable tax, for everything furnished and done under this Agreement.

The Company shall submit its applications for payment to Spokane Solid Waste Disposal, 2900 South Geiger Blvd, Spokane, Washington, 99224. **Payment will be made via direct deposit/ACH** within thirty (30) days after receipt of the Company's application except as provided by state law. If the City objects to all or any portion of the invoice, it shall notify the Company and reserves the right to only pay that portion of the invoice not in dispute. In that event, the parties shall immediately make every effort to settle the disputed amount

**5. TAXES, FEES AND LICENSES.**

- A. Company shall pay and maintain in current status, all necessary licenses, fees, assessments, permit charges, etc. necessary to conduct the work included under this Agreement. It is the Company's sole responsibility to monitor and determine changes or the enactment of any subsequent requirements for said fees, assessments, or changes and to immediately comply.
- B. The cost of any permits, licenses, fees, etc. arising as a result of the projects included in this Agreement shall be included in the project budgets.

**6. CITY OF SPOKANE BUSINESS LICENSE.**

Section 8.01.070 of the Spokane Municipal Code states that no person may engage in business with the City without first having obtained a valid annual business registration. The Company shall be responsible for contacting the State of Washington Business License Services at [www.dor.wa.gov](http://www.dor.wa.gov) or 360-705-6741 to obtain a business registration. If the Company does not believe it is required to obtain a business registration, it may contact the City's Taxes and Licenses Division at (509) 625-6070 to request an exemption status determination.

**Subcontractor:** Subcontractor expenses will be reimbursed at the actual cost incurred and may not include a markup. Copies of all Subcontractor invoices that are rebilled to the City are required.

**7. SOCIAL EQUITY REQUIREMENTS / NON-DISCRIMINATION.**

No individual shall be excluded from participation in, denied the benefit of, subjected to discrimination under, or denied employment in the administration of or in connection with this Agreement because of age, sex, race, color, religion, creed, marital status, familial status, sexual orientation including gender expression or gender identity, national origin, honorably discharged veteran or military status, the presence of any sensory, mental or physical disability, or use of a service animal by a person with disabilities. The Company agrees to comply with, and to require that all subcontractors comply with, federal, state and local nondiscrimination laws, including but not limited to: the Civil Rights Act of 1964, the Rehabilitation Act of 1973, the Age Discrimination in Employment Act, and the American's With Disabilities Act, to the extent those laws are applicable.

**8. INDEMNIFICATION.**

The Company shall defend, indemnify, and hold the City and its officers and employees harmless from all claims, demands, or suits at law or equity asserted by third parties for bodily injury (including death) and/or property damage which arise from the Company's negligence or willful misconduct under this Agreement, including attorneys' fees and litigation costs; provided that nothing herein shall require a Company to indemnify the City against and hold harmless the City from claims, demands or suits based solely upon the negligence of the City, its agents, officers, and employees. If a claim or suit is caused by or results from the concurrent negligence of the Company's agents or employees and the City, its agents, officers and employees, this indemnity provision shall be valid and enforceable to the extent of the negligence of the Company, its agents or employees. The Company specifically assumes liability and agrees to defend, indemnity, and hold the City harmless for actions

brought by the Company's own employees against the City and, solely for the purpose of this indemnification and defense, the Company specifically waives any immunity under the Washington State industrial insurance law, or Title 51 RCW. The Company recognizes that this waiver was specifically entered into pursuant to the provisions of RCW 4.24.115 and was the subject of mutual negotiation. The indemnity and agreement to defend and hold the City harmless provided for in this section shall survive any termination or expiration of this agreement.

## **9. INSURANCE.**

During the period of the Agreement, the Company shall maintain in force at its own expense, each insurance noted below with companies or through sources approved by the State Insurance Commissioner pursuant to Title 48 RCW:

A. **Worker's Compensation Insurance** in compliance with RCW 51.12.020, which requires subject employers to provide workers' compensation coverage for all their subject workers and Employer's Liability Insurance in the amount of \$1,000,000;

B. **General Liability Insurance** on an occurrence basis, with a combined single limit of not less than \$1,000,000 each occurrence for bodily injury and property damage. It shall include contractual liability coverage for the indemnity provided under this agreement. It shall provide that the City, its officers and employees are additional insureds but only with respect to the Company's services to be provided under this Agreement;

i. Acceptable supplementary Umbrella coverage in combination with Commercial General Liability policy shall be a minimum of \$2M in order to meet the minimum insurance coverages required under this contract; and

C. **Automobile Liability Insurance** with a combined single limit, or the equivalent of not less than \$1,000,000 each accident for bodily injury and property damage, including coverage for owned, hired and non-owned vehicles.

D. **Pollution Legal Liability Insurance** with a minimum coverage for Bodily Injury and Property Damage of not less than \$1,000,000 per occurrence and \$3,000,000 aggregate. Pollution Liability covers sums the Operator is legally obligated to pay as a result of emission, discharge, release or escape of any contaminants, irritants, or pollutants in or on land, the atmosphere, or any water course of body of water, provided this results in environmental damage.

There shall be no cancellation, material change, reduction of limits or intent not to renew the insurance coverage(s) without sixty (60) days written notice from the Company or its insurer(s) to the City. As evidence of the insurance coverage(s) required by this Agreement, the Company shall furnish acceptable Certificates Of Insurance (COI) to the City at the time it returns this signed Agreement. The certificate shall specify the City of Spokane as "Additional Insured" specifically for Company's services under this Agreement, as well as all of the parties who are additional insureds, and include applicable policy endorsements, the sixty (60) day cancellation clause, and the deduction or retention level. The Company shall be financially responsible for all pertinent deductibles, self-insured retentions, and/or self-insurance.

## **10. DEBARMENT AND SUSPENSION.**

The Company has provided its certification that it is in compliance with and shall not contract with individuals or organizations which are debarred, suspended, or otherwise excluded from or ineligible from participation in Federal Assistance Programs under Executive Order 12549 and "Debarment and Suspension", codified at 29 CFR part 98 (see Exhibit A).

**11. AUDIT.**

The Company and its subcontractor shall maintain for a minimum of three (3) years following final payment all records related to its performance of the Agreement. The Company and its subcontractors shall provide access to authorized City representatives, at reasonable times and in a reasonable manner to inspect and copy any such record. In the event of conflict between this provision and related auditing provisions required under federal law applicable to the Agreement, the federal law shall prevail.

**12. KEY PERSONS.**

The Company shall not transfer or reassign any individual designated in this Agreement as essential to the Work, nor shall those key persons, or employees of Company identified as to be involved in the Project Work be replaced, removed or withdrawn from the Work without the express written consent of the City, which shall not be unreasonably withheld. If any such individual leaves the Company's employment, the Company shall present to the City one or more individuals with greater or equal qualifications as a replacement, subject to the City's approval, which shall not be unreasonably withheld. The City's approval does not release the Company from its obligations under this Agreement.

**13. ASSIGNMENT AND SUBCONTRACTING.**

The Company shall not assign or subcontract its obligations under this Agreement without the City's written consent, which may be granted or withheld in the City's sole discretion. Any subcontract made by the Company shall incorporate by reference this Agreement, except as otherwise provided. The Company shall ensure that all subcontractors comply with the obligations and requirements of the subcontract. The City's consent to any assignment or subcontract does not release the Company from liability or any obligation within this Agreement, whether before or after City consent, assignment or subcontract.

**14. TERMINATION.**

Either party may terminate this Agreement, with or without cause, by ten (10) days written notice to the other party. In the event of such termination, the City shall pay the Company for all work previously authorized and performed prior to the termination date.

**15. STANDARD OF PERFORMANCE.**

The standard of performance applicable to Company's services will be the degree of skill and diligence normally employed by professional Companies performing the same or similar services at the time the services under this Agreement are performed.

**16. OWNERSHIP AND USE OF RECORDS AND DOCUMENTS.**

Original documents, drawings, designs, reports, or any other records developed or created under this Agreement shall belong to and become the property of the City. All records submitted by the City to the Company shall be safeguarded by the Company. The Company shall make such data, documents and files available to the City upon the City's request. If the City's use of the Company's records or data is not related to this project, it shall be without liability or legal exposure to the Company.

Under Washington State Law (reference RCW Chapter 42.56, the *Public Records Act* [PRA]) all materials received or created by the City of Spokane are **public records** and are available to the public for viewing via the City Clerk's Records (online) or a valid Public Records Request (PRR).

**17. ANTI KICK-BACK.**

No officer or employee of the City of Spokane, having the power or duty to perform an official act or action related to this Agreement shall have or acquire any interest in the Agreement, or have solicited, accepted or granted a present or future gift, favor, service or other thing of value from or to any person involved in this Agreement.

**18. MISCELLANEOUS PROVISIONS.**

- A. **Amendments/Modifications:** This Agreement may be modified by the City in writing when necessary, and no modification or Amendment of this Agreement shall be effective unless signed by an authorized representative of each of the parties hereto.
- B. The Company, at no expense to the City, shall comply with all laws of the United States and Washington, the Charter and ordinances of the City of Spokane; and rules, regulations, orders and directives of their administrative agencies and officers. Without limiting the generality of this paragraph, the Company shall comply with the requirements of this Section.
- C. This Agreement shall be construed and interpreted under the laws of Washington. The venue of any action brought shall be in a court of competent jurisdiction, located in Spokane County, Washington.
- D. **Captions:** The titles of sections or subsections are for convenience only and do not define or limit the contents.
- E. **Severability:** If any term or provision is determined by a court of competent jurisdiction to be invalid or unenforceable, the remainder of this Agreement shall not be affected, and each term and provision shall be valid and enforceable to the fullest extent permitted by law.
- F. **Waiver:** No covenant, term or condition or the breach shall be deemed waived, except by written consent of the party against whom the waiver is claimed, and any waiver of the breach of any covenant, term or condition shall not be deemed a waiver of any preceding or succeeding breach of the same or any other covenant, term of condition. Neither the acceptance by the City of any performance by the Company after the time the same shall have become due nor payment to the Company for any portion of the Work shall constitute a waiver by the City of the breach or default of any covenant, term or condition unless otherwise expressly agreed to by the City in writing.
- G. **Entire Agreement:** This document along with any exhibits and all attachments, and subsequently issued addenda, comprises the entire agreement between the City and the Firm. If conflict occurs between Agreement documents and applicable laws, codes, ordinances or regulations, the most stringent or legally binding requirement shall govern and be considered a part of this Agreement to afford the City the maximum benefits.
- H. **No personal liability:** No officer, agent or authorized employee of the City shall be personally responsible for any liability arising under this Agreement, whether expressed or implied, nor for any statement or representation made or in any connection with this Agreement.

IN WITNESS WHEREOF, in consideration of the terms, conditions and covenants contained, or attached and incorporated and made a part, the parties have executed this Agreement by having legally-binding representatives affix their signatures below.

**ACTION MATERIALS, INC.**

**CITY OF SPOKANE**

By \_\_\_\_\_  
Signature Date

By \_\_\_\_\_  
Signature Date

\_\_\_\_\_  
Type or Print Name

\_\_\_\_\_  
Type or Print Name

\_\_\_\_\_  
Title

\_\_\_\_\_  
Title

Attest:

Approved as to form:

\_\_\_\_\_  
City Clerk

\_\_\_\_\_  
Assistant City Attorney

**Attachments that are part of this Agreement:**

Exhibit A – Certificate Regarding debarment

Exhibit B – Action Materials, Inc. – Bid Response Summary dated September 25, 2024.

24-195



**EXHIBIT A**

**CERTIFICATION REGARDING DEBARMENT, SUSPENSION,  
INELIGIBILITY AND VOLUNTARY EXCLUSION**

1. The undersigned (i.e., signatory for the Subrecipient / Contractor / Consultant) certifies, to the best of its knowledge and belief, that it and its principals:
  - a. Are not presently debarred, suspended, proposed for debarment, declared ineligible, or voluntarily excluded from covered transactions by any federal department or agency;
  - b. Have not within a three-year period preceding this contract been convicted or had a civil judgment rendered against them for commission of fraud or a criminal offense in connection with obtaining, attempting to obtain, or performing a public (federal, state, or local) transaction or contract under a public transaction; violation of federal or state antitrust statutes or commission of embezzlement, theft, forgery, bribery, falsification or destruction of records, making false statements, tax evasion, receiving stolen property, making false claims, or obstruction of justice;
  - c. Are not presently indicted or otherwise criminally or civilly charged by a government entity (federal, state, or local) with commission of any of the offenses enumerated in paragraph (1)(b) of this certification; and,
  - d. Have not within a three-year period preceding this contract had one or more public transactions (federal, state, or local) terminated for cause or default.
  
2. The undersigned agrees by signing this contract that it shall not knowingly enter into any lower tier covered transaction with a person who is debarred, suspended, declared ineligible, or voluntarily excluded from participation in this covered transaction.
  
3. The undersigned further agrees by signing this contract that it will include the following clause, without modification, in all lower tier covered transactions and in all solicitations for lower tier covered transactions:

Certification Regarding Debarment, Suspension, Ineligibility and Voluntary Exclusion – Lower Tier Covered Transactions

1. The lower tier contractor certified, by signing this contract that neither it nor its principals is presently debarred, suspended, proposed for debarment, declared ineligible, or voluntarily excluded from participation in this transaction by any federal department or agency.
  
2. Where the lower tier contractor is unable to certify to any of the statements in this contract, such contractor shall attach an explanation to this contract.
  
4. I understand that a false statement of this certification may be grounds for termination of the contract.

Name of Subrecipient / Contractor / Consultant (Type or Print)	Program Title (Type or Print)
Name of Certifying Official (Type or Print)	Signature
Title of Certifying Official (Type or Print)	Date (Type or Print)

**EXHIBIT B**



< Business Lookup

License Information:

[New search](#) [Back to results](#)

**Entity name:** ACTION MATERIALS, INC.

**Business name:** ACTION MATERIALS, INC.

**Entity type:** [Profit Corporation](#)

**UBI #:** 602-478-373

**Business ID:** 001

**Location ID:** 0001

**Location:** Active

**Location address:** 8579 W WESTBOW BLVD  
BLDG B  
SPOKANE WA 99224

**Mailing address:** PO BOX 19425  
SPOKANE WA 99219-9425

**Excise tax and reseller permit status:** [Click here](#)

**Secretary of State status:** [Click here](#)

Endorsements

Endorsements held at this location	License #	Count	Details	Status	Expiration date	First issuance date
<a href="#">Benton City General Business - Non-Resident</a>	4622			<a href="#">Active</a>	Mar-31-2025	Feb-02-2022
<a href="#">Cheney General Business - Non-Resident</a>	BUS2010-424			<a href="#">Active</a>	Mar-31-2025	Jan-14-2019
<a href="#">Minor Work Permit</a>				<a href="#">Active</a>	Mar-31-2025	Apr-06-2015
<a href="#">Spokane General Business - Non-Resident</a>	T13084847BUS			<a href="#">Active</a>	Mar-31-2025	Oct-15-2012
<a href="#">Spokane Valley General Business - Non-Resident</a>				<a href="#">Active</a>	Mar-31-2025	Jun-11-2010
<a href="#">Yakima General Business - Non-Resident</a>				<a href="#">Active</a>	Mar-31-2025	Mar-09-2021

Governing People May include governing people not registered with Secretary of State

Governing people	Title
MATSON, WADE	

[View Additional Locations](#)

The Business Lookup information is updated nightly. Search date and time: 9/30/2024 10:59:29 AM

[Contact us](#)

How are we doing?  
[Take our survey!](#)

Don't see what you expected?  
[Check if your browser is supported](#)



< Business Lookup

### License Information:

[New search](#) [Back to results](#)

**Entity name:** ACTION MATERIALS, INC.

**Business name:** ACTION MATERIALS, INC.

**Entity type:** [Profit Corporation](#)

**UBI #:** 602-478-373

**Business ID:** 001

**Location ID:** 0001

**Location:** Active

**Location address:** 8579 W WESTBOW BLVD  
BLDG B  
SPOKANE WA 99224

**Mailing address:** PO BOX 19425  
SPOKANE WA 99219-9425

**Excise tax and reseller permit status:** [Click here](#)

**Secretary of State status:** [Click here](#)

### Endorsements

Endorsements held at this location	License #	Count	Details	Status	Expiration date	First issuance date
<a href="#">Benton City General Business - Non-Resident</a>	4622			<a href="#">Active</a>	Mar-31-2025	Feb-02-2022
<a href="#">Cheney General Business - Non-Resident</a>	BUS2010-424			<a href="#">Active</a>	Mar-31-2025	Jan-14-2019
<a href="#">Minor Work Permit</a>				<a href="#">Active</a>	Mar-31-2025	Apr-06-2015
<a href="#">Spokane General Business - Non-Resident</a>	T13084847BUS			<a href="#">Active</a>	Mar-31-2025	Oct-15-2012
<a href="#">Spokane Valley General Business - Non-Resident</a>				<a href="#">Active</a>	Mar-31-2025	Jun-11-2010
<a href="#">Yakima General Business - Non-Resident</a>				<a href="#">Active</a>	Mar-31-2025	Mar-09-2021

### Governing People May include governing people not registered with Secretary of State

Governing people	Title
MATSON, WADE	

[View Additional Locations](#)

The Business Lookup information is updated nightly. Search date and time: 9/30/2024 10:59:29 AM

[Contact us](#)

How are we doing?  
[Take our survey!](#)

Don't see what you expected?  
[Check if your browser is supported](#)

CERTIFICATE OF LIABILITY INSURANCE

DATE (MM/DD/YYYY)  
7/31/2024

THIS CERTIFICATE IS ISSUED AS A MATTER OF INFORMATION ONLY AND CONFERS NO RIGHTS UPON THE CERTIFICATE HOLDER. THIS CERTIFICATE DOES NOT AFFIRMATIVELY OR NEGATIVELY AMEND, EXTEND OR ALTER THE COVERAGE AFFORDED BY THE POLICIES BELOW. THIS CERTIFICATE OF INSURANCE DOES NOT CONSTITUTE A CONTRACT BETWEEN THE ISSUING INSURER(S), AUTHORIZED REPRESENTATIVE OR PRODUCER, AND THE CERTIFICATE HOLDER.

IMPORTANT: If the certificate holder is an ADDITIONAL INSURED, the policy(ies) must have ADDITIONAL INSURED provisions or be endorsed. If SUBROGATION IS WAIVED, subject to the terms and conditions of the policy, certain policies may require an endorsement. A statement on this certificate does not confer any rights to the certificate holder in lieu of such endorsement(s).

PRODUCER <b>USI Insurance Services NW</b> 201 West North River Drive STE 615 Spokane, WA 99201 509 456-2648	CONTACT NAME: <b>Jordynn Michelson</b>
	PHONE (A/C, No, Ext): <b>509-606-0245</b> FAX (A/C, No): <b>610-362-8530</b> E-MAIL ADDRESS: <b>jordynn.michelson@usi.com</b>
INSURED  <b>Action Materials Inc</b> <b>PO Box 19425</b> <b>Spokane, WA 99219</b>	INSURER(S) AFFORDING COVERAGE      NAIC #
	INSURER A : <b>Alaska National Insurance Company</b> <b>38733</b>
	INSURER B : <b>Mt. Hawley Insurance Company</b> <b>37974</b>
	INSURER C :
	INSURER D :
	INSURER E :

COVERAGES      CERTIFICATE NUMBER:      REVISION NUMBER:

THIS IS TO CERTIFY THAT THE POLICIES OF INSURANCE LISTED BELOW HAVE BEEN ISSUED TO THE INSURED NAMED ABOVE FOR THE POLICY PERIOD INDICATED. NOTWITHSTANDING ANY REQUIREMENT, TERM OR CONDITION OF ANY CONTRACT OR OTHER DOCUMENT WITH RESPECT TO WHICH THIS CERTIFICATE MAY BE ISSUED OR MAY PERTAIN, THE INSURANCE AFFORDED BY THE POLICIES DESCRIBED HEREIN IS SUBJECT TO ALL THE TERMS, EXCLUSIONS AND CONDITIONS OF SUCH POLICIES. LIMITS SHOWN MAY HAVE BEEN REDUCED BY PAID CLAIMS.

INSR LTR	TYPE OF INSURANCE	ADDL INSR	SUBR WVD	POLICY NUMBER	POLICY EFF (MM/DD/YYYY)	POLICY EXP (MM/DD/YYYY)	LIMITS
A	<input checked="" type="checkbox"/> COMMERCIAL GENERAL LIABILITY <input type="checkbox"/> CLAIMS-MADE <input checked="" type="checkbox"/> OCCUR <input checked="" type="checkbox"/> PD Ded:1,000 GEN'L AGGREGATE LIMIT APPLIES PER: <input type="checkbox"/> POLICY <input checked="" type="checkbox"/> PRO-JECT <input type="checkbox"/> LOC OTHER:	X	X	24CPS08767	03/04/2024	03/04/2025	EACH OCCURRENCE      \$1,000,000 DAMAGE TO RENTED PREMISES (Ea occurrence)      \$500,000 MED EXP (Any one person)      \$15,000 PERSONAL & ADV INJURY      \$1,000,000 GENERAL AGGREGATE      \$2,000,000 PRODUCTS - COMP/OP AGG      \$2,000,000 <b>WA Stop Gap</b> \$1,000,000
A	<input checked="" type="checkbox"/> AUTOMOBILE LIABILITY <input checked="" type="checkbox"/> ANY AUTO OWNED AUTOS ONLY <input type="checkbox"/> SCHEDULED AUTOS <input checked="" type="checkbox"/> HIRED AUTOS ONLY <input checked="" type="checkbox"/> NON-OWNED AUTOS ONLY <input checked="" type="checkbox"/> MCS90	X	X	24CAS08767	03/04/2024	03/04/2025	COMBINED SINGLE LIMIT (Ea accident)      \$1,000,000 BODILY INJURY (Per person)      \$ BODILY INJURY (Per accident)      \$ PROPERTY DAMAGE (Per accident)      \$ \$
A	<input checked="" type="checkbox"/> UMBRELLA LIAB <input checked="" type="checkbox"/> OCCUR <input type="checkbox"/> EXCESS LIAB <input type="checkbox"/> CLAIMS-MADE <input type="checkbox"/> DED <input checked="" type="checkbox"/> RETENTION \$ \$10,000	X	X	24CLU08767	03/04/2024	03/04/2025	EACH OCCURRENCE      \$4,000,000 AGGREGATE      \$4,000,000 \$ PER STATUTE      OTH-ER E.L. EACH ACCIDENT      \$ E.L. DISEASE - EA EMPLOYEE      \$ E.L. DISEASE - POLICY LIMIT      \$
	WORKERS COMPENSATION AND EMPLOYERS' LIABILITY ANY PROPRIETOR/PARTNER/EXECUTIVE OFFICER/MEMBER EXCLUDED?    Y / N (Mandatory in NH) If yes, describe under DESCRIPTION OF OPERATIONS below		N / A				
B	Pollution Li			EGL0011576	03/04/2024	03/04/2025	2,000,000 limit/Ded \$5k
A	Leased Rented Equ			24CIA08767	03/04/2024	03/04/2025	550,000 limit/Ded \$10k
A	Instal Floater			24CIA08767	03/04/2024	03/04/2025	25,000 jobsit/ Ded 2500

DESCRIPTION OF OPERATIONS / LOCATIONS / VEHICLES (ACORD 101, Additional Remarks Schedule, may be attached if more space is required)  
**The General Liability and Automobile Liability policies include an automatic Additional Insured endorsement that provides Additional Insured status to City of Spokane its officers and employees. only when there is a written contract that requires such status, and only with regard to work performed by or on behalf of the named insured. The General Liability policy contains a special endorsement with Primary and Noncontributory wording, when required by written contract. The General Liability and Automobile Liability (See Attached Descriptions)**

CERTIFICATE HOLDER  <b>City of Spokane</b> <b>808 W Spokane Falls Blvd.</b> <b>Spokane, WA 99201</b>	CANCELLATION SHOULD ANY OF THE ABOVE DESCRIBED POLICIES BE CANCELLED BEFORE THE EXPIRATION DATE THEREOF, NOTICE WILL BE DELIVERED IN ACCORDANCE WITH THE POLICY PROVISIONS. AUTHORIZED REPRESENTATIVE 
--	---

## DESCRIPTIONS (Continued from Page 1)

policies includes a Waiver of Subrogation endorsement in favor of the additional insureds as referenced above. Per Project Aggregate applies to General Liability policy per the attached endorsement

---

**CONTRACTORS' GENERAL LIABILITY ENHANCEMENT ENDORSEMENT**

---

**THIS ENDORSEMENT CHANGES THE POLICY. PLEASE READ IT CAREFULLY.**

This endorsement modifies insurance provided under the following:

**COMMERCIAL GENERAL LIABILITY COVERAGE PART**

Coverage afforded under this extension of coverage endorsement does not apply to any person or organization covered as an additional insured on any other endorsement now or hereafter attached to this Coverage Part.

**SCHEDULE OF COVERAGES ARE SUMMARIZED BELOW**

- |   |   |
|---|---|
| <p><b>1. Miscellaneous Additional Insureds</b><br/>8 additional insured extensions.</p> <p><b>Primary and Noncontributory Insurance</b></p> <p><b>2. Damage To Premises Rented to You</b><br/>Limit increased to \$500,000.</p> <p><b>3. Medical Payments</b><br/>Limits increased to \$15,000.<br/>Reporting period increased to three years from the date of accident.</p> <p><b>4. Non-owned Watercraft</b><br/>Increased to 50 feet.</p> <p><b>5. Supplementary Payments</b><br/>Cost of bail bonds increased to \$10,000.<br/>Daily loss of earnings increased to \$500.</p> <p><b>6. Newly Formed Or Acquired Organizations</b><br/>Coverage extended to the end of the policy period or the next anniversary of this policy's effective date.</p> <p><b>7. Liberalization Clause</b></p> <p><b>8. Unintentional Failure To Disclose Hazards</b></p> <p><b>9. Notice of Occurrence</b></p> <p><b>10. Broad Knowledge of Occurrence</b></p> <p><b>11. Bodily Injury - Extension of Coverage</b></p> <p><b>12. Expected Or Intended Injury</b><br/>Reasonable force - bodily injury or property damage.</p> | <p><b>13. Blanket Waiver of Subrogation</b><br/>Waiver of subrogation where required by written contract or written agreement.</p> <p><b>14. In Rem Actions</b></p> <p><b>15. Voluntary Property Damage</b><br/>Limits added: \$5,000 occurrence, \$10,000 aggregate.</p> <p><b>1. MISCELLANEOUS ADDITIONAL INSURED</b></p> <p><b>Section II Who Is An Insured</b> is amended to include as an additional Insured any person or organization described in Paragraphs <b>2.a.</b> through <b>2.h.</b> below whom you are required to add as an additional insured on this policy under a written contract or written agreement. However, the written contract or written agreement must be:</p> <ol style="list-style-type: none"><li>1. Currently in effect or becoming effective during the term of this policy; and</li><li>2. Executed prior to the "bodily injury", "property damage" or "personal injury and advertising injury", but</li></ol> <p>Only the following persons or organizations are additional insureds under this endorsement and coverage provided to such additional insureds is limited as provided herein:</p> <ol style="list-style-type: none"><li>a. <b>State or Governmental Agency or Subdivision or Political Subdivisions</b></li></ol> |
|---|---|

Any state or governmental agency or subdivision or political subdivision that has issued a permit in connection with operations performed by you or on your behalf and that you are required by any ordinance, law or building code to include as an additional insured on this coverage part is an additional insured, but only with respect to liability for "bodily injury", "property damage", "personal and advertising injury" arising out of such operations.

The insurance provided to such state or political subdivision does not apply to any "bodily injury", "property damage" or "personal and advertising injury" arising out of operations performed for that state or political subdivision.

**b. Controlling Interest**

Any persons or organizations with a controlling interest in you but only with respect to their liability arising out of:

- (1) Their financial control of you, or
- (2) Premises they own, maintain or control while you lease or occupy these premises.

This insurance does not apply to structural alterations, new construction and demolition operations performed by or for such additional insured.

**c. Managers or Lessors of Premises**

A manager or lessor of premises but only with respect to liability arising out of the ownership, maintenance or use of that specific part of the premises leased to you and subject to the following additional exclusions:

This insurance does not apply to:

- (1) Any "occurrence" which takes place after you cease to be a tenant in that premises; or

- (2) Structural alterations, new construction or demolition operations performed by or on behalf of such additional insured.

**d. Mortgagee, Assignee or Receiver**

A mortgagee, assignee or receiver but only with respect to their liability as mortgagee, assignee, or receiver and arising out of the ownership, maintenance, or use of a premises by you.

This insurance does not apply to structural alterations, new construction or demolition operations performed by or for such additional insured.

**e. Owners or Other Interests From Whom Land Has Been Leased**

An owner or other interest from whom land has been leased by you but only with respect to liability arising out of the ownership, maintenance or use of that specific part of the land leased to you and subject to the following additional exclusions:

This insurance does not apply to:

- (1) Any "occurrence" which takes place after you cease to lease that land; or
- (2) Structural alterations, new construction or demolition operations performed by or on behalf of such additional insured.

**f. Co-owner of Insured Premises**

A co-owner of a premises co-owned by you and covered under this insurance but only with respect to the co-owners liability as co-owner of such premises.



**g. Lessor of Equipment**

Any person or organization from whom you lease equipment. Such person or organization is an additional insured only with respect to their liability for “bodily injury”, “property damage” or “personal and Advertising injury” caused, in whole or in part, by your maintenance, operation or use of equipment leased to you by such person or organization. A person’s or organization’s status as an additional insured under this endorsement ends when their written contract or written agreement with you for such leased equipment ends.

With respect to the insurance afforded these additional insureds, the following additional exclusions apply:

This insurance does not apply:

- (1) To any “occurrence” which takes place after the equipment lease expires; or
- (2) To “bodily injury”, “property damage”, or “personal and advertising injury” arising out of the sole negligence of such additional insured.

**h. Owners, Lessees or Contractors – Ongoing Operations and Completed Operations**

1. Any person or organization for whom you are performing operations or have performed operations when you and such person or organization have agreed in writing in a contract or agreement that such person or organization be added as an additional insured on your policy; and
2. Any other person or organization you are required to add as an additional insured under the contract or agreement described in Paragraph 1. above.

Such person(s) or organization(s) is an additional insured only with respect to liability for “bodily injury”, “property damage” or “personal and advertising injury” caused, in whole or in part, by:

- a. Your acts or omissions; or
- b. The acts or omissions of those acting on your behalf; or
- c. “Your Work” performed for the additional insured described in Paragraph 1. or 2. above and included in the “products-completed operations hazard.”

In the performance of your ongoing operations or completed operations for the additional insured described in Paragraph 1. or 2. above.

However, the insurance afforded to such additional insured described above:

- a. Only applies to the extent permitted by law; and
- b. Will not be broader than that which you are required by the contract or agreement to provide for such additional insured.

3. With respect to the insurance afforded to these additional insureds, the following additional exclusions apply:

This insurance does not apply to:

1. “Bodily injury”, “property damage” or “personal and advertising injury” arising out of the rendering of, or the failure to render, any professional architectural, engineering or surveying services, including:

- a. The preparing, approving, or failing to prepare or approve, maps, shop drawings, opinions, reports, surveys, field orders, change orders or drawings and specifications; or
- b. Supervisory, inspection, architectural or engineering activities.

This exclusion applies even if the claims against any insured allege negligence or other wrongdoing in the supervision, hiring, employment, training or monitoring of others by that insured, if the "occurrence" which caused the "bodily injury" or "property damage", or the offense which caused the "personal and advertising injury", involved the rendering of, or the failure to render, any professional architectural, engineering or surveying services.

### Primary And Noncontributory Insurance

The following is added to the **Other Insurance** Condition and supersedes any provision to the contrary:

This insurance is primary to and will not seek contribution from any other insurance available to an additional insured under your policy provided that:

- (1) The additional insured is a Named Insured under such other insurance; and
- (2) You have agreed in writing in a contract or agreement that this insurance would be primary and would not seek contribution from any other insurance available to the additional insured.

**Section III - Limits of Insurance**, the following is added:

With respect to the insurance afforded to the additional insureds described in Paragraphs **a.** through **h.** above, the most we will pay on behalf of such additional insured is the amount of insurance:

- (1) Required by the contract or agreement; or
- (2) Available under the applicable Limits of Insurance shown in the Declarations;

whichever is less.

This provision shall not increase the applicable Limits of Insurance shown in the Declaration.

### 2. Damage To Premises Rented to You

**SECTION III – LIMITS OF INSURANCE**, Paragraph **6.** is replaced by the following:

6. Subject to Paragraph **5.** above, the Damage to Premises Rented to You Limit is the most we will pay under Coverage **A** for damages because of "property damage" to any one premises, while rented to you, or in the case of damage by fire, while rented to you or temporarily occupied by you with permission of the owner.

If a limit is shown for Damage to Premises Rented to You the most we will pay under Coverage **A** for damages because of "property damage" to any one premises is the Limit shown in the Declarations or \$500,000, whichever is greater.

### 3. MEDICAL PAYMENTS

**A. Section III – Limits of Insurance**, Paragraph **7.** is replaced by the following:

7. Subject to Paragraph **5.** above the Medical Expense Limit is the most we will pay under **Coverage C** for all medical expenses because of "bodily injury" sustained by any one person.

If a limit is shown for Medical Expense in the Declarations the most we will pay under Coverage C for all medical expenses because of "bodily injury" sustained by any one person is the Limit shown in the Declarations or \$15,000, whichever is greater.

**B.** This provision 5. (Medical Payments) does not apply if **Section I - Coverage C Medical Payments** is excluded either by the provisions of the Coverage Part or by endorsement.

**C.** Paragraph **1.a.(3)(b) of Section I - Coverage C - Medical Payments**, is replaced by the following:

(b) The expenses are incurred and reported to us within three years of the date of the accident; and

#### **4. NON-OWNED WATERCRAFT**

**A.** If endorsement **CG 21 09, CG 21 10, CG 24 50, or CG 24 51 is attached to the policy, Paragraph A. 2. g. (2) (b)** is replaced by the following:

(b) A watercraft that you do not own that is:

(i) Less than 50 feet long; and

(ii) Not being used to carry persons or property for a charge.

**B.** If Paragraph **A.** does not apply, Paragraph **g. (2) of 2. EXCLUSION under SECTION I – COVERAGES, COVERAGE A – BODILY INJURY AND PROPERTY DAMAGE LIABILITY** is replaced by the following:

(2) A watercraft that you do not own that is:

(a) Less than 50 feet long; and

(b) Not being used to carry persons or property for a charge.

#### **5. SUPPLEMENTARY PAYMENTS**

**A.** Under **Section I - Supplementary Payments - Coverage A and B, Paragraph 1.b.**, the limit of \$250 shown for the cost of bail bonds is replaced by \$10,000;

**B.** In Paragraph **1.d.**, the limit of \$250 shown for daily loss of earnings is replaced by \$500.

#### **6. NEWLY FORMED OR ACQUIRED ORGANIZATIONS**

Paragraph **3.a.** of **Section II - Who Is An Insured** is deleted and replaced by the following:

Coverage under this provision is afforded only until the end of the policy period or the next anniversary of this policy's effective date after you acquire or form the organization, whichever is earlier.

#### **7. LIBERALIZATION CLAUSE**

If we adopt a change in our forms or rules which would broaden coverage for contractors under this endorsement without an additional premium charge, your policy will automatically provide the additional coverages as of the date the revision is effective in your state.

#### **8. UNINTENTIONAL FAILURE TO DISCLOSE HAZARDS**

**SECTION IV – COMMERCIAL GENERAL LIABILITY CONDITIONS – Paragraph 6. – Representations** is replaced by the following:

##### **6. Representations**

By accepting this policy, you agree:

**a.** The statements in the Declarations are accurate and complete;

**b.** Those statements are based upon representations you made to us; and

**c.** We have issued this policy in reliance upon your representations.

The unintentional omission of, or unintentional error in, any information you provided to us which we relied upon in issuing this policy will not prejudice your rights under this insurance. However, this provision does not affect our right to collect additional premium or to exercise our rights of cancellation or nonrenewal in accordance with applicable laws and regulations.

## 9. NOTICE OF OCCURRENCE

The following is added to Paragraph 2. of **Section IV - Commercial General Liability Conditions - Duties In The Event of Occurrence, Offense, Claim or Suit:**

Your rights under this Coverage Part will not be prejudiced if you fail to give us notice of an "occurrence", offense, claim or "suit" and that failure is solely due to your reasonable belief that the "bodily injury" or "property damage" is not covered under this Coverage Part. However, you shall give written notice of this "occurrence", offense, claim or "suit" to us as soon as you are aware that this insurance may apply to such "occurrence", offense, claim or "suit."

## 10. BROAD KNOWLEDGE OF OCCURRENCE

The following is added to Paragraph 2. of **Section IV - Commercial General Liability Conditions - Duties in The Event of Occurrence, Offense, Claim or Suit:**

You must give us or our authorized representative notice of an "occurrence", offense, claim, or "suit" only when the "occurrence", offense, claim or "suit" is known to:

- (1) You, if you are an individual;
- (2) A partner, if you are a partnership;
- (3) An executive officer or the employee designated by you to give such notice, if you are a corporation; or

- (4) A manager, if you are a limited liability company.

## 11. EXPANDED BODILY INJURY

**Section V - Definitions**, the definition of "bodily injury" is changed to read:

"Bodily injury" means bodily injury, sickness or disease sustained by a person, including death, humiliation, shock, mental anguish or mental injury by that person at any time which results as a consequence of the bodily injury, sickness or disease.

## 12. EXPECTED OR INTENDED INJURY

Exclusion a. of **Section I - Coverage A - Bodily Injury and Property Damage Liability** is replaced by the following:

- a. "Bodily injury" or "property damage" expected or intended from the standpoint of the insured. This exclusion does not apply to "bodily injury" or "property damage" resulting from the use of reasonable force to protect persons or property.

## 13. BLANKET WAIVER OF SUBROGATION

The **Transfer Of Rights Of Recovery Against Others To Us Condition (Section IV - Commercial General Liability Conditions)** is amended by the addition of the following:

We waive any right of recovery against any person or organization, because of any payment we make under this Coverage Part, to whom the insured has waived its right of recovery in a written contract or agreement. Such waiver by us applies only to the extent that the insured has waived its right of recovery against such person or organization prior to loss.

#### 14. IN REM ACTIONS

Any action in rem against any vessel owned, operated by or for, or chartered by or for you will be treated in the same manner as though the action were in personam against you.

#### 15. VOLUNTARY PROPERTY DAMAGE

The following is added, **Section I – Coverage A – Bodily Injury and Property Damage Liability 1., Insuring Agreement:**

We will pay, at your request, for “property damage” to property of others while in the care, custody or control of an insured, arising out of your business operations away from your insured premises for which this policy is written and occurring during the policy period.

However, the “property damage” must be the result of unintentional damage or destruction but does not include disappearance, theft, or loss of use.

You agree with us that we shall have no duty to defend any claims and/or “suits” for which the only coverage provided is under this coverage extension.

For the purpose of this coverage only, **Section I – Coverage A – Bodily Injury and Property Damage Liability 2. Exclusions J. (4.) is deleted.**

As respects coverage afforded under Voluntary Property Damage, the following is added to **Section III – Limits of Insurance:**

Regardless of the number of insureds, claims or “suits” brought, or persons or organizations making claims or bringing “suits”:

1. Subject to 2. Below, the most we will pay for “property damage” arising from any one “occurrence” arising out of “property damage to property of others caused by you and while in your care, custody or control is \$5,000.
2. The most we will pay for the sum of all “property damage” in an annual policy period is \$10,000. This amount is part of and not in addition to the General Aggregate Limit described in Paragraph 2. of **Section III – Limits of Insurance.**

This endorsement changes the policy to which it is attached and, unless otherwise stated, is effective on the date issued at 12:01 A.M. standard time at your mailing address shown in the policy. **The information below is required only when this endorsement is issued subsequent to commencement of the policy.**

Endorsement Effective

Policy No.

Insured

Endorsement No.

Countersigned By \_\_\_\_\_

Includes copyrighted material of Insurance Services Office, Inc., with its permission

---

**BUSINESS AUTO COVERAGE ENHANCEMENT ENDORSEMENT**

---

**THIS ENDORSEMENT CHANGES THE POLICY. PLEASE READ IT CAREFULLY.**

This endorsement modifies insurance provided under the following:

**BUSINESS AUTO COVERAGE FORM**

Various provisions in this endorsement restrict coverage. Read the entire policy carefully to determine rights, duties, and what is and is not covered.

Throughout this policy, the words “you” and “your” refer to the Named Insured shown in the Declarations. The words “we”, “us”, and “our” refer to the company providing this insurance.

Other words and phrases that appear in quotation marks have special meaning. Refer to **SECTION V – DEFINITIONS** in the Business Auto Coverage Form.

The coverages provided by this endorsement apply per “accident” and, unless otherwise specified, are subject to all of the terms, conditions, exclusions and deductible provisions of the policy, to which it is attached.

**SECTION II – COVERED AUTO LIABILITY COVERAGE**, Paragraph A.1. Who Is An Insured is amended to include:

- d. Any “employee” of yours while operating an “auto” hired or rented under a contract or agreement in an “employee’s” name, with your permission, while performing duties related to the conduct of your business.
- e. Any person or organization for whom you have agreed in writing to provide insurance such as is afforded by this Coverage Form, but only with respect to liability arising out of the ownership, maintenance or use of “autos” covered by this policy. If such person or organization has other insurance then this insurance is primary to and we will not seek contribution from the other insurance.

**SECTION IV – Business Auto Conditions, Paragraph A. 5. – Transfer of Rights of Recovery Against Others To Us** is amended to include:

**5. Transfer of Rights of Recovery Against Others to Us**

This condition does not apply to any person(s) or organization(s) to the extent that

subrogation against that person or organization is waived prior to the “accident” or the “loss” under a contract with that person or organization.

**SECTION II – COVERED AUTO LIABILITY COVERAGE**, Paragraph A.2.a. (2) – **Supplementary Payments** is replaced by the following:

- (2) Up to \$10,000 for cost of bail bonds (including bonds for related traffic law violations) required because of an “accident” we cover. We do not have to furnish these bonds.

**SECTION II – COVERED AUTO LIABILITY COVERAGE**, Paragraph A.2.a. (4) – **Supplementary Payments** is replaced by the following:

- (4) All reasonable expenses incurred by the “insured” at our request, including actual loss of earnings up to \$500 a day because of time off from work.

**SECTION II – COVERED AUTO LIABILITY COVERAGE**, Paragraph A.2.c. – **Voluntary Property Damage** is added as follows:

**c. Voluntary Property Damage**

At your written request, we may make a voluntary payment for Property Damage caused by an “insured”, but without liability to a third party, up to \$25,000. We will not make a Voluntary Property Damage payment to anyone who is an “insured” under this policy.

**SECTION III – PHYSICAL DAMAGE COVERAGE**, Paragraph A.2. – **Towing** is replaced by the following:

**Towing**

We will pay up to \$500 for towing and labor costs incurred each time a covered “auto” that is a:

- a. Private passenger;

- b. Truck;
- c. Pick-up truck;
- d. Panel ; or
- e. Van

type vehicle under 20,000 lbs. of Gross Vehicle Weight is disabled. However, the labor must be performed at place of disablement.

**SECTION III – PHYSICAL DAMAGE COVERAGE, Paragraph A.3. – Glass Breakage – Hitting a Bird or Animal – Falling Objects or Missiles** is replaced by the following:

**Glass Breakage – Hitting a Bird or Animal – Falling Objects or Missiles**

If you carry Comprehensive Coverage for the damaged covered “auto”, we will pay the following under Comprehensive Coverage:

- a. Glass Breakage;
- b. “Loss” caused by hitting a bird or animal; and
- c. “Loss” caused by falling objects or missiles.

However, you have the option of having glass breakage caused by a covered “auto’s” collision or overturn considered a “loss” under Collision Coverage.

**Glass Repair – Waiver of Deductible**

No deductible applies to glass breakage, if the glass is repaired rather than replaced.

**SECTION III – PHYSICAL DAMAGE COVERAGE, Paragraph A.4.a. – Transportation Expenses** is replaced by the following:

**a. Transportation Expenses**

We will pay up to \$200 per day to a maximum of \$1,500 for temporary transportation expense incurred by you because of the total theft of a covered “auto” that is a:

- (1) Private passenger;
- (2) Truck;

- (3) Pick-up truck;
- (4) Panel; or
- (5) Van

type vehicle under 20,000 lbs. of Gross Vehicle Weight. We will pay only for those covered “autos” for which you carry either Comprehensive or Specified Causes of Loss Coverage. We will pay for temporary transportation expenses incurred during the period beginning 48 hours after the theft and ending, regardless of the policy’s expiration, when the covered “auto” is returned to use or we pay for its “loss”.

**SECTION III – PHYSICAL DAMAGE COVERAGE, Paragraph A.4.b. – Loss of Use Expenses** is replaced by the following:

**b. Loss of Use Expenses – Hired, Rented, or Borrowed Automobiles**

We will pay expenses for which an “insured” becomes legally responsible to pay for loss of use of a vehicle hired, rented or borrowed without a driver under a written rental contract or agreement. We will pay for loss of use expenses, if caused by:

- (1) Other than Collision, only if the Declarations indicate that Comprehensive Coverage is provided for the vehicle withdrawn from service.
- (2) Specified Causes of Loss only if the Declarations indicate that Specified Causes of Loss Coverage is provided for the vehicle withdrawn from service.
- (3) Collision only if the Declarations indicate that Collision Coverage is provided for the vehicle withdrawn from service.

However, the most we will pay for any expenses for loss of use is \$200 per day, to a maximum of \$1,500.

**SECTION III – PHYSICAL DAMAGE COVERAGE,**  
Paragraph A.4.c. – **Non-Transportation Loss of Use Expenses** is added as follows:

**c. Non-Transportation Loss of Use Expenses**

We will pay up to \$2,000 for non-transportation expense incurred by you, because of “loss” to a covered “auto”, if caused by:

- (1) Other than Collision, only if the Declarations indicate that Comprehensive Coverage is provided for the “auto” withdrawn from service;
- (2) Specified Causes of Loss only if the Declarations indicate that Specified Causes of Loss Coverage is provided for the “auto” withdrawn from service; or
- (3) Collision only if the Declarations indicate that Collision Coverage is provided for the “auto” withdrawn from service.

**SECTION III – PHYSICAL DAMAGE COVERAGE,**  
Paragraph A.4.d. – **Airbag Coverage** is added as follows:

**d. Airbag Coverage**

We will pay for the cost to repair, replace, or reset an airbag that inflates for any reason other than as a result of a collision, if the Declarations indicate that the covered “auto” has Comprehensive Coverage or Specified Causes of Loss Coverage.

**SECTION III – PHYSICAL DAMAGE COVERAGE,**  
Paragraph A.4.e. – **Rental Reimbursement Coverage** is added as follows:

**e. Rental Reimbursement Coverage**

We will pay up to \$75 per day for rental reimbursement expenses incurred by you for the rental of an “auto” because of “loss” to a covered “auto” that is a:

- (1) Private Passenger;

- (2) Truck;
- (3) Pick-up truck;
- (4) Panel; or
- (5) Van

type vehicle under 20,000 lbs. of Gross Vehicle Weight. Payment applies in addition to the otherwise applicable amount of each coverage you have on a covered “auto”. No deductibles apply to this coverage.

- (1) We will pay only for those expenses incurred during the policy period beginning 24 hours after the “loss” and ending, regardless of the policy’s expiration, with the lesser of the following number of days:
  - (a) The number of days reasonably required to repair or replace the covered “auto”.
  - (b) 30 days.
- (2) This coverage does not apply while there are spare or reserve “autos” available to you for your operations.
- (3) The Rental Reimbursement Coverage described above does not apply to a covered “auto” that is described or designated as a covered “auto” on Rental Reimbursement Coverage Form CA 99 23.

**SECTION IV – BUSINESS AUTO CONDITIONS –**  
Paragraph B.2. – Concealment, Misrepresentation Or Fraud is amended by adding **Unintentional Failure to Disclose Hazards** at the end of Paragraph B.2. as follows:

**Unintentional Failure to Disclose Hazards**

If you unintentionally fail to disclose any hazards existing at the inception date of your policy, we will not deny coverage under this Coverage Form because of such failure. However, this provision does not affect our right to collect additional premium or exercise our right of cancellation or non-renewal.



**SECTION IV – BUSINESS AUTO CONDITIONS –**  
Paragraph B.5.b. – **Other Insurance** is replaced by the following:

- b. For Hired Auto Physical Damage Coverage, the following are deemed to be covered “autos” you own:
- (1) Any covered “auto” you lease, hire, rent, or borrow; and
  - (2) Any covered “auto” hired or rented by your “employee” under a contract in that individual “employee’s” name, with your permission, while performing duties related to the conduct of your business.

However, any “auto” that is leased, hired, rented or borrowed with a driver is not a covered “auto”.

**SECTION V – DEFINITIONS –** Paragraph C. – **“Bodily injury”** is replaced by the following:

- C. “Bodily injury” means bodily injury, sickness or disease sustained by a person including death or mental anguish resulting from any of these. Mental anguish means any type of mental or emotional illness or disease

---

**DESIGNATED CONSTRUCTION PROJECT(S) GENERAL AGGREGATE LIMIT**

---

**THIS ENDORSEMENT CHANGES THE POLICY. PLEASE READ IT CAREFULLY.**

This endorsement modifies insurance provided under the following:

COMMERCIAL GENERAL LIABILITY COVERAGE PART

**SCHEDULE**

**Designated Construction Project(s):**

All Projects

Information required to complete this Schedule, if not shown above, will be shown in the Declarations.

- A.** For all sums which the insured becomes legally obligated to pay as damages caused by "occurrences" under Section **I** – Coverage **A**, and for all medical expenses caused by accidents under Section **I** – Coverage **C**, which can be attributed only to ongoing operations at a single designated construction project shown in the Schedule above:
1. A separate Designated Construction Project General Aggregate Limit applies to each designated construction project, and that limit is equal to the amount of the General Aggregate Limit shown in the Declarations.
  2. The Designated Construction Project General Aggregate Limit is the most we will pay for the sum of all damages under Coverage **A**, except damages because of "bodily injury" or "property damage" included in the "products-completed operations hazard", and for medical expenses under Coverage **C** regardless of the number of:
    - a. Insureds;
    - b. Claims made or "suits" brought; or
    - c. Persons or organizations making claims or bringing "suits".
  3. Any payments made under Coverage **A** for damages or under Coverage **C** for medical expenses shall reduce the Designated Construction Project General Aggregate Limit for that designated construction project. Such payments shall not reduce the General Aggregate Limit shown in the Declarations nor shall they reduce any other Designated Construction Project General Aggregate Limit for any other designated construction project shown in the Schedule above.
  4. The limits shown in the Declarations for Each Occurrence, Damage To Premises Rented To You and Medical Expense continue to apply. However, instead of being subject to the General Aggregate Limit shown in the Declarations, such limits will be subject to the applicable Designated Construction Project General Aggregate Limit.

- B.** For all sums which the insured becomes legally obligated to pay as damages caused by "occurrences" under Section I – Coverage **A**, and for all medical expenses caused by accidents under Section I – Coverage **C**, which cannot be attributed only to ongoing operations at a single designated construction project shown in the Schedule above:
1. Any payments made under Coverage **A** for damages or under Coverage **C** for medical expenses shall reduce the amount available under the General Aggregate Limit or the Products-completed Operations Aggregate Limit, whichever is applicable; and
  2. Such payments shall not reduce any Designated Construction Project General Aggregate Limit.
- C.** When coverage for liability arising out of the "products-completed operations hazard" is provided, any payments for damages because of "bodily injury" or "property damage" included in the "products-completed operations hazard" will reduce the Products-completed Operations Aggregate Limit, and not reduce the General Aggregate Limit nor the Designated Construction Project General Aggregate Limit.
- D.** If the applicable designated construction project has been abandoned, delayed, or abandoned and then restarted, or if the authorized contracting parties deviate from plans, blueprints, designs, specifications or timetables, the project will still be deemed to be the same construction project.
- E.** The provisions of Section III – Limits Of Insurance not otherwise modified by this endorsement shall continue to apply as stipulated.

This endorsement changes the policy to which it is attached and, unless otherwise stated, is effective on the date issued at 12:01 A.M. standard time at your mailing address shown in the policy. **The information below is required only when this endorsement is issued subsequent to commencement of the policy.**

Endorsement Effective

Policy No.

Insured

Endorsement No. 22

Countersigned By \_\_\_\_\_

---

**STOP GAP - EMPLOYERS LIABILITY COVERAGE ENDORSEMENT - WASHINGTON**

---

**THIS ENDORSEMENT CHANGES THE POLICY. PLEASE READ IT CAREFULLY.**

This endorsement modifies insurance provided under the following:

COMMERCIAL GENERAL LIABILITY COVERAGE FORM

**SCHEDULE**

Limits Of Insurance		
<b>Bodily Injury By Accident</b>	\$1,000,000	<b>Each Accident</b>
<b>Bodily Injury By Disease</b>	\$1,000,000	<b>Aggregate Limit</b>
<b>Bodily Injury By Disease</b>	\$1,000,000	<b>Each Employee</b>
Information required to complete this Schedule, if not shown above, will be shown in the Declarations.		

**A. The following is added to Section I – Coverages:**

**Stop Gap – Employers Liability Coverage**

**1. Insuring Agreement**

a. We will pay those sums that the insured becomes legally obligated by Washington Law to pay as damages because of "bodily injury by accident" or "bodily injury by disease" to your "employee" to which this insurance applies. We will have the right and duty to defend the insured against any "suit" seeking those damages. However, we will have no duty to defend the insured against any "suit" seeking damages to which this insurance does not apply. We may, at our discretion, investigate any accident and settle any claim or "suit" that may result. But:

- (1) The amount we will pay for damages is limited as described in **Section III – Limits Of Insurance**; and
- (2) Our right and duty to defend end when we have used up the applicable limit of insurance in the payment of judgments or settlements under this coverage.

No other obligation or liability to pay sums or perform acts or services is covered unless explicitly provided for under Supplementary Payments.

**b. This insurance applies to "bodily injury by accident" or "bodily injury by disease" only if:**

**(1) The:**

- (a) "Bodily injury by accident" or "bodily injury by disease" takes place in the "coverage territory";
- (b) "Bodily injury by accident" or "bodily injury by disease" arises out of and in the course of the injured "employee's" employment by you; and
- (c) "Employee", at the time of the injury, was covered under a workers' compensation policy and subject to a "workers' compensation law" of Washington; and

**(2) The:**

- (a) "Bodily injury by accident" is caused by an accident that occurs during the policy period; or

- (b) "Bodily injury by disease" is caused by or aggravated by conditions of employment by you and the injured "employee's" last day of last exposure to the conditions causing or aggravating such "bodily injury by disease" occurs during the policy period.
- c. The damages we will pay, where recovery is permitted by law, include damages:
  - (1) For:
    - (a) Which you are liable to a third party by reason of a claim or "suit" against you by that third party to recover the damages claimed against such third party as a result of injury to your "employee";
    - (b) Care and loss of services; and
    - (c) Consequential "bodily injury by accident" or "bodily injury by disease" to a spouse, child, parent, brother or sister of the injured "employee";provided that these damages are the direct consequence of "bodily injury by accident" or "bodily injury by disease" that arises out of and in the course of the injured "employee's" employment by you; and
  - (2) Because of "bodily injury by accident" or "bodily injury by disease" to your "employee" that arises out of and in the course of employment, claimed against you in a capacity other than as employer.

## 2. Exclusions

This insurance does not apply to:

### a. Intentional Injury

"Bodily injury by accident" or "bodily injury by disease" intentionally caused or aggravated by you, or "bodily injury by accident" or "bodily injury by disease" resulting from an act which is determined to have been committed by you if it was reasonable to believe that an injury is substantially certain to occur.

### b. Fines Or Penalties

Any assessment, penalty or fine levied by any regulatory inspection agency or authority.

### c. Statutory Obligations

Any obligation of the insured under a workers' compensation, disability benefits or unemployment compensation law or any similar law.

### d. Contractual Liability

Liability assumed by you under any contract or agreement.

### e. Violation Of Law

"Bodily injury by accident" or "bodily injury by disease" suffered or caused by any employee while employed in violation of law with your actual knowledge or the actual knowledge of any of your "executive officers".

### f. Termination, Coercion Or Discrimination

Damages arising out of coercion, criticism, demotion, evaluation, reassignment, discipline, defamation, harassment, humiliation, discrimination against or termination of any "employee", or arising out of other employment or personnel decisions concerning the insured.

### g. Failure To Comply With "Workers' Compensation Law"

"Bodily injury by accident" or "bodily injury by disease" to an "employee" when you are:

- (1) Deprived of common law defenses; or
- (2) Otherwise subject to penalty;

because of your failure to secure your obligations or other failure to comply with any "workers' compensation law".

### h. Violation Of Age Laws Or Employment Of Minors

"Bodily injury by accident" or "bodily injury by disease" suffered or caused by any person:

- (1) Knowingly employed by you in violation of any law as to age; or
- (2) Under the age of 14 years, regardless of any such law.

### i. Federal Laws

Any premium, assessment, penalty, fine, benefit, liability or other obligation imposed by or granted pursuant to:

- (1) The Federal Employer's Liability Act (45 USC Section 51-60);

- (2) The Non-appropriated Fund Instrumentalities Act (5 USC Sections 8171-8173);
- (3) The Longshore and Harbor Workers' Compensation Act (33 USC Sections 910-950);
- (4) The Outer Continental Shelf Lands Act (43 USC Section 1331-1356);
- (5) The Defense Base Act (42 USC Sections 1651-1654);
- (6) The Federal Coal Mine Health and Safety Act of 1969 (30 USC Sections 901-942);
- (7) The Migrant and Seasonal Agricultural Worker Protection Act (29 USC Sections 1801-1872);
- (8) Any other workers compensation, unemployment compensation or disability laws or any similar law; or
- (9) Any subsequent amendments to the laws listed above.

**j. Punitive Damages**

Multiple, exemplary or punitive damages.

**k. Crew Members**

"Bodily injury by accident" or "bodily injury by disease" to a master or member of the crew of any vessel or any member of the flying crew of an aircraft.

**B. The Supplementary Payments** provisions apply to **Stop Gap - Employers Liability Coverage** as well as to Coverages **A** and **B**.

**C. For the purposes of this endorsement, Section II – Who Is An Insured** is replaced by the following:

**Section II – Who Is An Insured**

If you are designated in the Declarations as:

1. An individual, you and your spouse are insureds, but only with respect to the conduct of a business of which you are the sole owner.
2. A partnership or joint venture, you are an insured. Your members, your partners, and their spouses are also insureds, but only with respect to the conduct of your business.
3. A limited liability company, you are an insured. Your members are also insureds, but only with respect to the conduct of your business. Your managers are insureds, but only with respect to their duties as your managers.

4. An organization other than a partnership, joint venture or limited liability company, you are an insured. Your "executive officers" and directors are insureds, but only with respect to their duties as your officers or directors. Your stockholders are also insureds, but only with respect to their liability as stockholders.

No person or organization is an insured with respect to the conduct of any current or past partnership, joint venture or limited liability company that is not shown as a Named Insured in the Declarations.

**D. For the purposes of this endorsement, Section III – Limits Of Insurance** is replaced by the following:

1. The Limits Of Insurance shown in the Schedule of this endorsement and the rules below fix the most we will pay regardless of the number of:
  - a. Insureds;
  - b. Claims made or "suits" brought; or
  - c. Persons or organizations making claims or bringing "suits".
2. The "Bodily Injury By Accident" – Each Accident Limit shown in the Schedule of this endorsement is the most we will pay for all damages covered by this insurance because of "bodily injury by accident" to one or more "employees" in any one accident.
3. The "Bodily Injury By Disease" – Aggregate Limit shown in the Schedule of this endorsement is the most we will pay for all damages covered by this insurance and arising out of "bodily injury by disease", regardless of the number of "employees" who sustain "bodily injury by disease".
4. Subject to Paragraph **D.3.** of this endorsement, the "Bodily Injury By Disease" – Each "Employee" Limit shown in the Schedule of this endorsement is the most we will pay for all damages because of "bodily injury by disease" to any one "employee".

The limits of the coverage apply separately to each consecutive annual period and to any remaining period of less than 12 months, starting with the beginning of the policy period shown in the Declarations, unless the policy period is extended after issuance for an additional period of less than 12 months. In that case, the additional period will be deemed part of the last preceding period for purposes of determining the Limits of Insurance.

E. For the purposes of this endorsement, Condition **2. Duties In The Event Of Occurrence, Claim Or Suit** under **Section IV - Conditions** is replaced by the following:

**2. Duties In The Event Of Injury, Claim Or Suit**

a. You must see to it that we or our agent is notified as soon as practicable of a "bodily injury by accident" or "bodily injury by disease" which may result in a claim. To the extent possible, notice should include:

- (1) How, when and where the "bodily injury by accident" or "bodily injury by disease" took place;
- (2) The names and addresses of any injured persons and witnesses; and
- (3) The nature and location of any injury.

b. If a claim is made or "suit" is brought against any insured, you must:

- (1) Immediately record the specifics of the claim or "suit" and the date received; and
- (2) Notify us as soon as practicable.

You must see to it that we receive written notice of the claim or "suit" as soon as practicable.

c. You and any other involved insured must:

- (1) Immediately send us copies of any demands, notices, summonses or legal papers received in connection with the injury, claim, proceeding or "suit";
- (2) Authorize us to obtain records and other information;
- (3) Cooperate with us and assist us, as we may request, in the investigation or settlement of the claim or defense against the "suit";
- (4) Assist us, upon our request, in the enforcement of any right against any person or organization which may be liable to the insured because of injury to which this insurance may also apply; and

(5) Do nothing after an injury occurs that would interfere with our right to recover from others.

d. No insured will, except at that insured's own cost, voluntarily make a payment, assume any obligation, or incur any expense, other than for first aid, without our consent.

F. For the purposes of this endorsement, Paragraphs **4.** and **18.** of the **Definitions** section are replaced by the following:

**4.** "Coverage territory" means:

- a. The United States of America (including its territories and possessions), Puerto Rico and Canada;
- b. International waters or airspace, but only if the injury or damage occurs in the course of travel or transportation between any places included in **a.** above; or
- c. All other parts of the world if the injury or damage arises out of the activities of a person whose home is in the territory described in **a.** above, but who is away for a short time on your business;

provided the insured's responsibility to pay damages is determined in the United States (including its territories and possessions), Puerto Rico or Canada, in a suit on the merits according to the substantive law in such territory, or in a settlement we agree to.

**18.** "Suit" means a civil proceeding in which damages because of "bodily injury by accident" or "bodily injury by disease" to which this insurance applies are alleged. "Suit" includes:

- a. An arbitration proceeding in which such damages are claimed and to which the insured must submit or does submit with our consent; or
- b. Any other alternative dispute resolution proceeding in which such damages are claimed and to which the insured submits with our consent.

G. The following are added to the **Definitions** section:

1. "Workers' Compensation Law" means the Workers' Compensation Law and any Occupational Disease Law of Washington. This does not include provisions of any law providing non-occupational disability benefits.
2. "Bodily injury by accident" means bodily injury, sickness or disease sustained by a person, including death, resulting from an accident. A disease is not "bodily injury by accident" unless it results directly from "bodily injury by accident".

3. "Bodily injury by disease" means a disease sustained by a person, including death. "Bodily injury by disease" does not include a disease that results directly from an accident.

H. For the purposes of this endorsement, the definition of "bodily injury" does not apply.

This endorsement changes the policy to which it is attached and, unless otherwise stated, is effective on the date issued at 12:01 A.M. standard time at your mailing address shown in the policy. **The information below is required only when this endorsement is issued subsequent to commencement of the policy.**

Endorsement Effective

Policy No.

Insured Action Materials Inc.

Endorsement No.

Countersigned By \_\_\_\_\_



**Bid Response Summary**

**Bid Number** RFQ 6237-24  
**Bid Title** Dump Truck Services for Transport of Topsoil  
**Due Date** Wednesday, September 25, 2024 9:00:00 AM [(UTC-08:00) Pacific Time (US & Canada)]  
**Bid Status** Open for Bidding  
**Company** Action Materials, INC  
**Submitted By** Joshua Calkins - Tuesday, September 24, 2024 2:51:25 PM [(UTC-08:00) Pacific Time (US & Canada)]  
 joshua@actionmaterials.net

**Comments****Question Responses**

Group	Reference Number	Question	Response
BACKGROUND			
	#1	The City of Spokane, Solid Waste Disposal, Waste To Energy Facility (COS WTE), is located at 2900 S. Geiger Blvd, Spokane WA 99224-5400. COS WTEF operates a 24-hour/365 day per year environment and works under aggressive deadlines and schedules that require vendors to provide high service levels. COS WTEF is initiating this Invitation To Bid to solicit Bids from vendors who have a proven ability to provide Dump Truck Services for Transport of Topsoil.	Acknowledged
BID SUBMISSION			
	#1	Bid Responses shall be submitted electronically through the City of Spokane's bidding portal: <a href="https://spokane.procureware.com">https://spokane.procureware.com</a> on or before the Due Date and time mentioned above. Hard, e-mailed or faxed copies and/or late bids shall not be accepted.	Acknowledged
	#2	The City of Spokane is not responsible for bids electronically submitted late. It is the responsibility of the Bidder to be sure the bids are electronically submitted sufficiently ahead of time to be received no later than 1:00 p.m. Pacific Local Time, on the bid due date.	Acknowledged
	#3	All communication between the Bidder and the City upon receipt of this bid shall be via the "Clarification Tab" within ProcureWare. Any other communication will be considered unofficial and non-binding on the City	Acknowledged
INTERPRETATION			
	#1	If the Bidder discovers any errors, discrepancies, or omissions in the Bid specifications, or has any questions about the specifications, the Bidder must notify Purchasing in writing. Any addenda issued by the Purchaser will be incorporated into the contract or purchase order.	I agree and I acknowledge

WITHDRAWAL OF QUOTES		
#1	Bidders may quote prior to the scheduled bid due date. Unless otherwise specified, no Bids may be withdrawn for a minimum of ninety (90) calendar days after the bid due date.	I agree and I acknowledge
EVALUATIONS OF BIDS		
1	Evaluation of Quotes Shall be based upon the following criteria, where applicable: A. The price, including sales tax and the effect of discounts. Price may be determined by life cycle costing or total cost quoting, when advantageous to the Purchaser. B. The quality of the items quoted, their conformity to specifications and the purpose for which they are required. C. The Bidder's ability to provide prompt and efficient service and/or delivery. D. The character, integrity, reputation, judgment, experience and efficiency of the Bidder. E. The quality of performance of previous contracts or services. F. The previous and existing compliance by the Bidder with the laws relating to the contract or services. G. Uniformity or interchangeability. H. The energy efficiency of the product throughout its life. I. Any other information having a bearing on the decision to award the contract.	Acknowledged
QUOTING ERRORS		
#1	Unit pricing will prevail in the circumstance of unit and extension pricing discrepancies. When, after the opening and tabulation of Bids, a Bidder claims error, and requests to be relieved of award, he will be required to promptly present certified work sheets. The Purchaser will review the work sheets and if the Purchaser is convinced, by clear and convincing evidence, that an honest, mathematically excusable error or critical omission of costs has been made, the Bidder may be relieved of his Bid.	I acknowledge and I understand
REJECTION OF QUOTES		
#1	The Purchaser reserves the right to reject any or all Bids; to waive minor deviations from the specifications, to waive any informality in bids received, whenever it is in the Purchaser's best interest, and to accept or reject all or part of this Bid at prices shown.	I agree and I acknowledge
AWARD OF CONTRACT		

#1	<p>Award of contract or purchase, when made, will be to the Bidder whose Bid is the most favorable to the Purchaser, taking into consideration price and the other evaluation factors. STATE CONTRACTS WHERE APPLICABLE WILL BE CONSIDERED AS A BID. The City Council shall make the award of contract or purchase. Unsuccessful Bidders will not automatically be notified of Bid results.</p>	I agree and I acknowledge
PAYMENT TERMS		
#1	<p>Payment shall be made Net 30 via direct deposit/ACH (except as provided by state law) according to terms after receipt of the goods/services delivered and accepted. A completed ACH application is required before a City order will be issued. If the City objects to all or any portion of an invoice, it shall notify the supplier and reserve the right to pay only that portion of the invoice not in dispute. In that event, all parties shall immediately make every effort to settle the disputed amount.</p>	I agree and I acknowledge
INVOICING		
#1	<p>Invoices must be submitted to Spokane Solid Waste Disposal within 30 days of a transport. • All Invoices shall include OPR Contract Number, Copies of Weigh Tickets, for Quantity of Tons Transported that are being invoiced per Unit Pricing per Contract. • Payment of invoices shall be contingent upon receipt of sufficient detail to permit identification of the transported tons, and compliance with contract conditions. Original invoices are required and shall not be approved for payment until all required support is provided. Invoices shall be emailed to mdorgan@spokanecity.org.</p>	I agree and I acknowledge
TERMS AND CONDITIONS		
#1	<p>Bidder acknowledges that they have read and understand the Terms and Conditions Document in the "Documents" tab. If answer is "I don't agree and I don't acknowledge", include requested exception in proposal submittal on separate page and title as "Exception to Terms and Conditions". The City will consider and determine if exception will be accepted.</p>	I agree and I acknowledge
#1.2	<p>EXCEPTION: If you took exception above, upload here.</p>	

<p>#2</p>	<p>ELIGIBILITY FOR CITY CONTRACTS: Section 18.09.050 of the Spokane Municipal Code states that the recipient of a City contract, award or purchase order shall certify that it is not knowingly or intentionally a nuclear weapons producer. The Bidder certifies that his/her firm is not a nuclear weapons producer.</p>	<p>I certify</p>
<p>BIDDER INFORMATION</p>		
<p>#1</p>	<p>Please indicate the appropriate point of contact (including phone number and email) regarding this Bid and placement of orders if awarded. If these actions will not be managed by the same person, please explicitly specify all relevant contacts.</p>	<p>Joshua Calkins (509) 993-4936 joshua@actionmaterials.net</p>
<p>ORGANIZATION</p>		
<p>#1</p>	<p>Organization: Bidder Should Enter If Proposal Is of an Individual, Partnership, Corporation, and Existing Under The Laws of What US State. Enter Information Here</p>	<p>Corporation</p>
<p>BUSINESS REGISTRATION:</p>		
<p>1</p>	<p>Section 8.01.070 of the Spokane Municipal Code states that no person may engage in business with the City without first having obtained and being the holder of a valid annual business registration or temporary business registration as provided in this chapter. The supplier shall be responsible for contacting the State of Washington Business License Services at <a href="http://bls.dor.wa.gov">http://bls.dor.wa.gov</a> or 1-360-705-6741 to obtain a business registration. If the supplier does not believe it is required to obtain a business registration, it may contact the City's Taxes and Licenses Division at 509-625-6070 to request an exemption status determination.</p>	<p>I agree and I acknowledge</p>
<p>2</p>	<p>City of Spokane Business Registration Number:</p>	<p>602478373</p>
<p>PROPRIETARY INFORMATION/PUBLIC DISCLOSURE</p>		
Empty section for proprietary information/public disclosure		

1	<p>Materials submitted in response to this competitive procurement shall become the property of the City. All received Proposals shall remain confidential until the award of contract recommendation has been filed with the applicable Council Committee or the City Clerk for City Council action. Thereafter, the Proposals shall be deemed public records as defined in RCW 42.56, "Public Records." Any information in the Proposal that the Proposer desires to claim as proprietary and thus exempt from disclosure under the provisions of existing state law, shall be clearly designated. Each page claimed to be exempt from disclosure must be clearly identified by the word "Confidential" printed on it. Marking the entire Proposal exempt from disclosure will not be honored. The City will consider a Proposer's request for exemption from disclosure; however, the City will make a decision predicated upon state law and regulations. If any information is marked as proprietary in the Proposal, it will not be made available until the affected Proposer has been given an opportunity to seek a court injunction against the requested disclosure.</p>	I agree and I acknowledge
<p><b>BIDDER PREQUALIFICATION</b></p>		
#1	<p>Prior to award of contract or purchase, Bidders shall be required to submit evidence of sufficient facilities, equipment, experience and financial ability to insure completion of the work, unless waived by the COS WTEF.</p>	I agree and I acknowledge
<p><b>INSURANCE</b></p>		
1	<p>INSURANCE. During the period of the Agreement, the Company shall maintain in force at its own expense, each insurance noted below with companies or through sources approved by the State Insurance Commissioner pursuant to Title 48 RCW:</p>	I agree and I acknowledge
2	<p>A. Worker's Compensation Insurance in compliance with RCW 51.12.020 which requires subject employers to provide worker's compensation coverage for all their subject workers and Employer's Liability Insurance in the amount of \$1,000,000.00.</p>	I agree and I acknowledge
<p> </p>		

3	<p>B. General Liability Insurance on an occurrence basis, with a combined single limit of not less than \$1,000,000 each occurrence for bodily injury and property damage. It shall include contractual liability coverage for the indemnity provided under this Agreement. It shall provide that the City, its officers and employees are additional insureds but only with respect to the Company's services to be provided under this Agreement</p>	I agree and I acknowledge
#3.1	<p>i. Acceptable supplementary Umbrella insurance coverage combined with Company's General Liability insurance policy must be a minimum of \$1,000,000, in order to meet the insurance coverage limits required in this Agreement; and</p>	I agree and I acknowledge
4	<p>C. Automobile Liability Insurance with a combined single limit, or the equivalent of not less than \$1,000,000 each accident for bodily injury and property damage, including coverage for owned, hired and non-owned vehicles.</p>	I agree and I acknowledge
5	<p>D. Pollution Legal Liability Insurance with a minimum coverage for Bodily Injury and Property Damage of not less than \$1,000,000 per occurrence and \$3,000,000 aggregate. Pollution Liability covers sums the Operator is legally obligated to pay as a result of emission, discharge, release, or escape of any contaminants, irritants, or pollutants in or on land, the atmosphere, or any water course or body of water, provided this results in environmental damage.</p>	I agree and I acknowledge
6	<p>There shall be no cancellation, material change, reduction of limits or intent not to renew the insurance coverage(s) without thirty (30) days written notice from the Company or its insurer(s) to the City. As evidence of the insurance coverage(s) required by this Agreement, the Company shall furnish acceptable Certificates of Insurance (COI) upon request by the City. The certificate shall specify the City of Spokane as "Additional Insured" specifically for Company's services under this Agreement, as well as all of the parties who are additional insureds, and include applicable policy endorsements, the thirty (30) day cancellation clause, and the deduction or retention level. The Company shall be financially responsible for all pertinent deductibles, self-insured retentions, and/or self-insurance</p>	I agree and I acknowledge
<p>MINORITY BUSINESS ENTERPRISE</p>		

<p>#1</p>	<p>Vendor ( IS ) ( IS NOT ) a Minority Business Enterprise. A Minority Business Enterprise is defined as a “business, privately or publicly owned, at least 51% of which is owned by minority group members.” For purpose of this definition, minority group members are Blacks, Hispanics, Asian Americans, American Indian or Alaskan Natives, or Women.</p>	<p>Is Not</p>
<p><b>SMALL BUSINESS</b></p>		
<p>#1</p>	<p>Vendor ( IS ) ( IS NOT ) a small business concern. (A small business concern for the purpose of government procurement is a concern, including its affiliates, which is independently owned and operated, is not dominant in the field of operations in which it is bidding on government contracts, and can further qualify under the criteria concerning number of employees, average annual receipts, or other criteria as prescribed by the Small Business Administration).</p>	<p>Is Not</p>
<p><b>NON-COLLUSION</b></p>		
<p>#1</p>	<p>The Bidder certifies that his/her firm has not entered into any agreement of any nature whatsoever to fix, maintain, increase, or reduce the prices or competition regarding the items covered by this Bid invitation.</p>	<p>Certifies No Agreement Has Been Entered</p>
<p><b>ACCEPTANCE PERIOD</b></p>		
<p>#1</p>	<p>Bids must provide a minimum of ninety (90) calendar days for acceptance by the City from the bid due date.</p>	<p>I agree and I acknowledge</p>
<p><b>CONTRACT RENEWALS</b></p>		
<p>#1</p>	<p>Contract renewals or extensions shall be initiated at the discretion of the City and subject to mutual agreement. Resulting contract may be extended for two (2) additional one-year contract periods with the total contract period not to exceed three (3) years. Annual Price increases must be submitted to the City for approval. The City may require backup documentation for such price increase.</p>	<p>I agree and I acknowledge</p>
<p><b>TERM OF CONTRACT</b></p>		
<p>1</p>	<p>Upon City Council approval, the Contract resulting from this RFQ will be for a one-year period, beginning approximately November 15, 2024, and terminate on November 14, 2025. The Vendor’s prices shall be firm throughout the first year.</p>	<p>I agree and I acknowledge</p>
<p><b>GENERAL INSTRUCTIONS</b></p>		

#2	Time is of the essence in the performance of this contract.	I agree and I acknowledge
#3	Successful bidder will designate a representative who will be available during regular City business hours to serve as a primary contact for the City if any issues arise regarding service.	I agree and I acknowledge
#4	The City of Spokane reserves the right to accept or reject any variance from the published requirements and to award the Bid in a manner that is most advantageous to the continued efficient operation of the City.	I agree and I acknowledge
#5	The City reserves the right to accept or reject any part of or all Bids, and to accept the Bid deemed to be in the best interest of the City.	I agree and I acknowledge
#6	The City may choose from more than one vendor. The City of Spokane reserves the option of awarding by type or grouping, or by any manner most advantageous for the City.	I agree and I acknowledge
#7	Bidder should be aware that Bids may be rejected if all questions are not completely and correctly answered.	I agree and I acknowledge
<b>TECHNICAL REQUIREMENTS</b>		
#1	Performance Unless otherwise stated, the Vendor will be responsible for the furnishing of all labor, supervision, materials, tools, construction equipment, transportation, and other items of work and costs necessary for the proper performance and completion of the described Work. The apparent silence or omission as to any detail of any Work to be done or materials to be furnished and required for the proper performance of the Work, shall be regarded as meaning that the best general practice is to prevail, and that material and workmanship of the best quality are to be used, and interpretation of the scope of work shall be made upon this basis.	I agree and I acknowledge
#2	Scope of Work The scope of Services will include, but is not limited to, the following:	Yes
#2.1	Awarded vendor shall provide topsoil transport from American Recycling Corp., 6203 E. Mission Ave, Spokane Valley, WA 99212 to Northside Landfill, 7202 Nine Mile Road, Spokane, WA 99208.	I agree and I acknowledge
#2.2	Topsoil is expected to be contaminated with garbage debris intermixed. No testing data is available regarding topsoil.	We understand
#2.2.1	The Northside Landfill will use the topsoil as ground cover.	I agree and I acknowledge



#2.3	The Vendor shall have 12yd to 15yd rear dump box tandem axle trucks, with Pup Trailers to be able to transport 18 tons per each transport.	I agree and I acknowledge
#2.4	American Recycling will be responsible for loading Vendor's vehicles.	I agree and I acknowledge
#2.5	Vendor must ensure all load are tarped, prior to transporting.	I agree and I acknowledge
#2.6	Vendor shall ensure a weight ticket it submitted for each transport being invoiced. Load Tickets must be obtained from American Recycling.	I agree and I acknowledge
#2.7	Vendor will only be paid for actual tons transported, based on contract's all-inclusive-transported-cost-per-ton, supported by weigh tickets.	I agree and I acknowledge
#2.8	EXCEPTIONS If you marked "I do not acknowledge and agree" on any of the areas above, explain here what you are taking exception to.	
TRANSPORTS		
#1	SERVICE SCHEDULE: Vendor shall be responsible for coordinating deliveries with American Recycling and COS WTEF, Vendor is responsible to ensure minimum load weights are met. It is expected that transports are to occur between the hours of 6:00AM - 3:00PM, during weekdays of Monday, Tuesday, Wednesday, and Thursday. The COS WTEF retains the right to change time frames and weekdays.	I agree and I acknowledge
#1.1	Quantities shown are estimates only and are not guaranteed. Actual usage may be more or less.	I agree and I acknowledge
#1.2	Each transport is estimated to be 18 Tons.	I agree and I acknowledge
#1.3	Annual Estimated Quantity is 3,640 tons, equating to 200 transports, with each transport being 18 tons. Payment would only be made for actual transports performed supported by weigh tickets, throughout the term of Contract and any renewals.	I agree and I acknowledge
#2	Successful Vendor must use high quality, safe equipment and operating procedures.	I agree and I acknowledge
#3	DELIVERY - F.O.B. POINT: Transferred and unloaded at designated location at the Northside Landfill, 7202 Nine Mile Road, Spokane, WA 99208.	I agree and I acknowledge
#3.1	Vendor will be held responsible to comply with the established receiving program.	I agree and I acknowledge
#3.2	Vendor shall adhered to All WTEF Safety procedures shall be while on WTEF premises.	I agree and I acknowledge
DELIVERY DEFAULT		

#1	The acceptance of late performance by the Purchaser shall not waive the right to claim damage for such breach nor constitute a waiver of the requirements for the timely performance of any obligations remaining to be performed by Vendor.	I agree and I acknowledge
#2	Purchaser may procure from another source and Vendor will be required to pay any differences in cost.	I agree and I acknowledge
PRICING		
#1	Sales Tax: The City of Spokane is not a tax exempt entity and is therefore obligated to pay sales tax under Washington State law. Sales tax should --not-- be included in bidder's unit pricing. All submissions shall be tabulated by the City who with the applicable sales tax rate whether that tax shall be charged through the supplier or paid by the City as use tax.	I agree and I acknowledge
#2	Bidder acknowledges it would apply applicable Sale, which currently is 9%, when invoicing.	I agree and I acknowledge
#3	Unit Pricing should Not Include Tax.	I agree and I acknowledge
#4	Bidder's prices shall be firm throughout the first year of the contract period.	Yes
#5	Unit Pricing shall be all-inclusive-cost-per-Transported-Ton.	I agree and I acknowledge
#5.1	All-inclusive-cost-per-Transported-Ton shall be all-inclusive of cost that could be incurred, to include but not limited to: Transport, Obtaining Weigh Tickets, Delivery, Unloading, Demurrage Charges, and any Fuel Surcharge.	I agree and I acknowledge
#5.2	Bidder acknowledges that ALL expenses that could be incurred were taken into account in Vendor's all-inclusive-cost-per-Transported-Ton stated on Pricing Form. No other costs will be allowed later.	I agree and I acknowledge
#6	Bidder has completed Pricing Form,	Yes
#7	PRICING ADJUSTMENTS:	Yes

#8.1	<p>Adjustments to pricing shall be the result of increases at the manufacturer's level, incurred after contract commencement date, shall not produce a higher profit margin than that on the original contract, clearly identify the items impacted by the increase, and be accompanied by documentation acceptable to Spokane City sufficient to justify the requested increase. Spokane City will be the sole judge as to the acceptability of sources. Acceptance of a request will be at the sole discretion of Spokane City. Price increases will not be considered before the end of the first 12-months of the Contract. Approved price adjustments shall remain unchanged for at least 12 months thereafter unless due to extraordinary circumstances as documented by the Contractor and concurred with by the City. A written request for a price adjustment will be considered on anniversary date of contract award, should renewal be exercised. An approved price increase Retroactive price increase adjustments will not be considered.</p>	I agree and I acknowledge
#8.2	<p>Back up documentation from Vendor must be included to justify request.</p>	I agree and I acknowledge
#8.3	<p>All price adjustments must be agreed on by both parties. Vendor must request pricing adjustment in writing, and cannot be applied retroactively to transports already performed. Price increases must apply to all or broad classes of customers and shall in no way single out the Purchaser.</p>	I agree and I acknowledge
#8.4	<p>The City of Spokane reserves the right to cancel the contract if the escalation of price is not advantageous to the City. Failure to reach agreement on a request for an increase in price(s) can, at the sole option of the City, result in the termination of the Agreement for cause.</p>	I agree and I acknowledge
#9	<p>PRICE DECREASES. During the term of the contract, should the Vendor realize any or cost reductions, or enter into pricing agreements with other customers providing greater benefits or lower pricing, The Vendor shall immediately request that an amendment to the Contract to provide similar pricing to the City, if the contract with other customers offers similar usage quantities, and similar conditions impacting pricing. The Vendor shall immediately notify the City of any such contracts entered into by the Vendor. Price decreases may be considered and implemented at any time upon mutual consent of the parties.</p>	I agree and I acknowledge

ADDITIONAL DOCUMENTS BIDDER WOULD LIKE TO UPLOAD	
#1	If you have additional information/documents to submit, upload them here.
#2	If you have additional information/documents to submit, upload them here.
#3	If you have additional information/documents to submit, upload them here.
#4	If you have additional information/documents to submit, upload them here.

**Pricing Responses**

Group	Reference Number	Description	Type	Unit Of Measure	Quantity	Unit Price	Ext Base Price	Comment
<p>Annual Quantities shown on "Pricing Tab" are estimates only and are not to be construed as firm or guaranteed. Quantities are estimates only and are given for the purpose of comparing bids on a uniform basis. Unit Pricing SHOULD NOT include tax.</p>								
	#1	All-inclusive Unit Price per Transported-Ton shall be firm throughout the first year of the contract period. Annual estimated quantity is 3,640 Tons. Unit price should not include tax.	Base	Transported Cost Per Ton	3,640.00	\$14.25	\$51,870.00	
<b>Total Base Bid</b>							\$51,870.00	



**Agenda Sheet for City Council:**

**Committee:** PIES **Date:** 10/21/2024

**Committee Agenda type:** Consent

**Date Rec'd** 10/22/2024

**Clerk's File #** OPR 2024-0928

**Cross Ref #**

**Project #**

**Council Meeting Date:** 11/04/2024

<b>Submitting Dept</b>	SOLID WASTE DISPOSAL	<b>Bid #</b>	RFQ 6237-24
------------------------	----------------------	--------------	-------------

<b>Contact Name/Phone</b>	DAVID PAINE 625-6878	<b>Requisition #</b>	CR 26787
---------------------------	----------------------	----------------------	----------

<b>Contact E-Mail</b>	DPAINE@SPOKANECITY.ORG		
-----------------------	------------------------	--	--

<b>Agenda Item Type</b>	Contract Item		
-------------------------	---------------	--	--

<b>Council Sponsor(s)</b>	BWILKERSON JBINGLE KKLITZKE		
---------------------------	-----------------------------	--	--

<b>Agenda Item Name</b>	4490-CONTRACT FOR TRANSPORTATION OF TOPSOIL TO THE NORTHSIDE		
-------------------------	--	--	--

**Agenda Wording**

Contract award 2 of 2 from RFQ 6237-24 with Circle M Construction & Landscape Supplies, Inc. (Spokane Valley, WA) for topsoil hauling to the City's Northside Landfill from 11/15/2024-11/14/2025 and a total cost not to exceed \$65,000.00 plus tax.

**Summary (Background)**

The City's Landfill requires topsoil to use as ground cover for the active cell. American Recycling has a large amount of soil that can be used for this purpose. It would be obtained at no cost but Solid Waste Disposal would need to haul the soil. RFQ 6237-24 was issued for this service and three responses were received. The contract will be awarded to the two lowest-bidders; Action Materials and Circle M Landscaping. This will allow soil to be hauled as-needed without scheduling conflicts.

Lease? NO Grant related? NO Public Works? NO

**Fiscal Impact**

Approved in Current Year Budget? YES

Total Cost	\$ 65,000.00
------------	--------------

Current Year Cost	\$ 0
-------------------	------

Subsequent Year(s) Cost	\$ 0
-------------------------	------

**Narrative**

This is an operating supply/contractual services expense that was planned for in the Solid Waste Disposal budget. This was awarded to two bidders, but overall spend between both contracts is anticipated to be no more than \$65,000.00.

**Amount**

**Budget Account**

Expense	\$ 65,000.00	# 4530-44800-53748-54201
Select	\$	#
Select	\$	#
Select	\$	#
	\$	#
	\$	#



# Continuation of Wording, Summary, Approvals, and Distribution

## Agenda Wording

## Summary (Background)

### **Approvals**

<b><u>Dept Head</u></b>	AVERYT, CHRIS
<b><u>Division Director</u></b>	FEIST, MARLENE
<b><u>Accounting Manager</u></b>	ALBIN-MOORE, ANGELA
<b><u>Legal</u></b>	SCHOEDEL, ELIZABETH
<b><u>For the Mayor</u></b>	PICCOLO, MIKE

### **Additional Approvals**

<b><u>PURCHASING</u></b>	PRINCE, THEA

### **Distribution List**

Mark Townsend, mark@spokanelandscape.net	mdorgan@spokanecity.org
jsalstrom@spokanecity.org	tprince@spokanecity.org
rrinderle@spokanecity.org	

## Committee Agenda Sheet

### Public Infrastructure, Environment & Sustainability Committee

<b>Committee Date</b>	October 21, 2024
<b>Submitting Department</b>	Solid Waste Disposal
<b>Contact Name</b>	David Paine
<b>Contact Email &amp; Phone</b>	<a href="mailto:dpaine@spokanecity.org">dpaine@spokanecity.org</a> , 509-625-6878
<b>Council Sponsor(s)</b>	Wilkerson, Bingle, Klitzke
<b>Select Agenda Item Type</b>	<input checked="" type="checkbox"/> Consent <input type="checkbox"/> Discussion    Time Requested:
<b>Agenda Item Name</b>	Contract for transportation of topsoil for the Northside Landfill
<b>Proposed Council Action</b>	<input checked="" type="checkbox"/> Approval to proceed to Legislative Agenda <input type="checkbox"/> Information Only
<b>Summary (Background)</b>	<p>The City's Northside Landfill requires topsoil to use as ground cover for the active cell. American Recycling has a large amount of topsoil that needs removed from their facility that can be used for this purpose. The soil would be obtained at no cost but the Solid Waste Disposal department needs to facilitate the transportation of the soil.</p> <p>On September 25, 2024, bidding closed on RFQ 6237-24 for dump truck services for transportation of topsoil. Three responses were received. Due to scheduling needs of this project, the contract will be awarded to the two lowest bidders; Action Materials (Spokane, WA) and Circle M Construction &amp; Landscape Supplies, Inc. (Spokane Valley, WA). The contracts will begin on November 15, 2024 and run through November 14, 2025 with a total cost not to exceed \$65,000.00 plus applicable taxes.</p>
<b>Summary (Background)</b>	<p>*use the Fiscal Impact box below for relevant financial information</p>
<b>Fiscal Impact</b>	
<b>Approved in current year budget?</b> <input checked="" type="checkbox"/> Yes <input type="checkbox"/> No <input type="checkbox"/> N/A Total Cost: <u>\$65,000.00</u> Current year cost: \$65,000.00 Subsequent year(s) cost: 0	
<b>Narrative:</b> <u>This is an operating supplies expense that was planned for in the Solid Waste Disposal budget.</u>	
<b>Funding Source</b> <input type="checkbox"/> One-time <input checked="" type="checkbox"/> Recurring <input type="checkbox"/> N/A Specify funding source: Program revenue Is this funding source sustainable for future years, months, etc? Yes	
<b>Expense Occurrence</b> <input checked="" type="checkbox"/> One-time <input type="checkbox"/> Recurring <input type="checkbox"/> N/A  Other budget impacts: (revenue generating, match requirements, etc.)	
<b>Operations Impacts (If N/A, please give a brief description as to why)</b>	
<ul style="list-style-type: none"> <li>What impacts would the proposal have on historically excluded communities?            Public works services and projects are designed to serve all citizens and businesses. We strive to offer a consistent level of service to all, to distribute public investment throughout the community and to respond to gaps in services identified in various City plans.</li> </ul>	

- How will data be collected, analyzed, and reported concerning the effect of the program/policy by racial, ethnic, gender identity, national origin, income level, disability, sexual orientation, or other existing disparities?  
N/A
- How will data be collected regarding the effectiveness of this program, policy, or product to ensure it is the right solution?  
Public Works follows the City's established procurement and public works bidding regulations and policies to bring items forward, and then uses contract management best practices to ensure desired outcomes and regulatory compliance.
- Describe how this proposal aligns with current City Policies, including the Comprehensive Plan, Sustainability Action Plan, Capital Improvement Program, Neighborhood Master Plans, Council Resolutions, and others?  
This work is consistent with annual budget strategies to limit costs and approved projects in the 6-year CIP.

**Council Subcommittee Review**

- Please provide a summary of council subcommittee review. If not reviewed by a council subcommittee, please explain why not.

Not applicable





**City of Spokane**  
**PERSONAL SERVICES AGREEMENT**  
**Title: DUMP TRUCK SERVICES**

This Agreement is made and entered into by and between the **CITY OF SPOKANE** as (“City”), a Washington municipal corporation, and **CIRCLE M CONSTRUCTION & LANDSCAPE SUPPLIES, INC.**, whose address is 1820 North University Road, Spokane Valley, Washington 99206 as (“Company”), individually hereafter referenced as a “Party”, and together as the “Parties”.

*WHEREAS, the purpose of this Agreement is to provide Dump Truck Services for Transport of Topsoil for the Waste to Energy Facility; and*

*WHEREAS, the Company was selected through RFQ 6237-24 issued by the City.*

*NOW, THEREFORE, in consideration of the terms, conditions, covenants and performance of the Scope of Work contained herein, the City and Company mutually agree as follows:*

**1. TERM OF AGREEMENT.**

The term of this Agreement begins on November 14, 2024, and shall run through November 15, 2025, unless amended by written agreement or terminated earlier under the provisions. This Agreement may be extended by written agreement of the parties not to exceed two (2) additional one year contract renewal periods.

**2. TIME OF BEGINNING AND COMPLETION.**

The Company shall begin the work outlined in the “Scope of Work” (“Work”) on the beginning date, above. The City will acknowledge in writing when the Work is complete. Time limits established under this Agreement shall not be extended because of delays for which the Company is responsible, but may be extended by the City, in writing, for the City’s convenience or conditions beyond the Company’s control.

**3. SCOPE OF WORK.**

The General Scope of Work for this Agreement is described in Circle M Construction & Landscape Supplies, Inc., - RFQ 6237-24 Bid Response Summary dated September 25, 2024, which is attached as **Exhibit B** and made a part of this Agreement. In the event of a conflict or discrepancy in the Agreement documents, this City Personal Services Agreement controls.

The Work is subject to City review and approval. The Company shall confer with the City periodically, and prepare and present information and materials (e.g. detailed outline of completed Work) requested by the City to determine the adequacy of the Work or Company’s progress.

**4. COMPENSATION / PAYMENT.**

Total compensation for Company’s services under this Agreement shall not exceed **SIXTY-FIVE**

**THOUSAND AND NO/100 DOLLARS (\$65,000.00)**, and applicable tax, for everything furnished and done under this Agreement.

The Company shall submit its applications for payment to Spokane Solid Waste Disposal, 2900 South Geiger Blvd, Spokane, Washington, 99224. **Payment will be made via direct deposit/ACH** within thirty (30) days after receipt of the Company's application except as provided by state law. If the City objects to all or any portion of the invoice, it shall notify the Company and reserves the right to only pay that portion of the invoice not in dispute. In that event, the parties shall immediately make every effort to settle the disputed amount

**5. TAXES, FEES AND LICENSES.**

- A. Company shall pay and maintain in current status, all necessary licenses, fees, assessments, permit charges, etc. necessary to conduct the work included under this Agreement. It is the Company's sole responsibility to monitor and determine changes or the enactment of any subsequent requirements for said fees, assessments, or changes and to immediately comply.
- B. The cost of any permits, licenses, fees, etc. arising as a result of the projects included in this Agreement shall be included in the project budgets.

**6. CITY OF SPOKANE BUSINESS LICENSE.**

Section 8.01.070 of the Spokane Municipal Code states that no person may engage in business with the City without first having obtained a valid annual business registration. The Company shall be responsible for contacting the State of Washington Business License Services at [www.dor.wa.gov](http://www.dor.wa.gov) or 360-705-6741 to obtain a business registration. If the Company does not believe it is required to obtain a business registration, it may contact the City's Taxes and Licenses Division at (509) 625-6070 to request an exemption status determination.

**Subcontractor:** Subcontractor expenses will be reimbursed at the actual cost incurred and may not include a markup. Copies of all Subcontractor invoices that are rebilled to the City are required.

**7. SOCIAL EQUITY REQUIREMENTS / NON-DISCRIMINATION.**

No individual shall be excluded from participation in, denied the benefit of, subjected to discrimination under, or denied employment in the administration of or in connection with this Agreement because of age, sex, race, color, religion, creed, marital status, familial status, sexual orientation including gender expression or gender identity, national origin, honorably discharged veteran or military status, the presence of any sensory, mental or physical disability, or use of a service animal by a person with disabilities. The Company agrees to comply with, and to require that all subcontractors comply with, federal, state and local nondiscrimination laws, including but not limited to: the Civil Rights Act of 1964, the Rehabilitation Act of 1973, the Age Discrimination in Employment Act, and the American's With Disabilities Act, to the extent those laws are applicable.

**8. INDEMNIFICATION.**

The Company shall defend, indemnify, and hold the City and its officers and employees harmless from all claims, demands, or suits at law or equity asserted by third parties for bodily injury (including death) and/or property damage which arise from the Company's negligence or willful misconduct under this Agreement, including attorneys' fees and litigation costs; provided that nothing herein shall require a Company to indemnify the City against and hold harmless the City from claims, demands or suits based solely upon the negligence of the City, its agents, officers, and employees. If a claim or suit is caused by or results from the concurrent negligence of the Company's agents or employees and the City, its agents, officers and employees, this indemnity provision shall be valid and enforceable to the extent of the negligence of the Company, its agents or employees. The Company specifically assumes liability and agrees to defend, indemnity, and hold the City harmless for actions

brought by the Company's own employees against the City and, solely for the purpose of this indemnification and defense, the Company specifically waives any immunity under the Washington State industrial insurance law, or Title 51 RCW. The Company recognizes that this waiver was specifically entered into pursuant to the provisions of RCW 4.24.115 and was the subject of mutual negotiation. The indemnity and agreement to defend and hold the City harmless provided for in this section shall survive any termination or expiration of this agreement.

## **9. INSURANCE.**

During the period of the Agreement, the Company shall maintain in force at its own expense, each insurance noted below with companies or through sources approved by the State Insurance Commissioner pursuant to Title 48 RCW:

A. **Worker's Compensation Insurance** in compliance with RCW 51.12.020, which requires subject employers to provide workers' compensation coverage for all their subject workers and Employer's Liability Insurance in the amount of \$1,000,000;

B. **General Liability Insurance** on an occurrence basis, with a combined single limit of not less than \$1,000,000 each occurrence for bodily injury and property damage. It shall include contractual liability coverage for the indemnity provided under this agreement. It shall provide that the City, its officers and employees are additional insureds but only with respect to the Company's services to be provided under this Agreement;

i. Acceptable supplementary Umbrella coverage in combination with Commercial General Liability policy shall be a minimum of \$2M in order to meet the minimum insurance coverages required under this contract; and

C. **Automobile Liability Insurance** with a combined single limit, or the equivalent of not less than \$1,000,000 each accident for bodily injury and property damage, including coverage for owned, hired and non-owned vehicles.

D. **Pollution Legal Liability Insurance** with a minimum coverage for Bodily Injury and Property Damage of not less than \$1,000,000 per occurrence and \$3,000,000 aggregate. Pollution Liability covers sums the Operator is legally obligated to pay as a result of emission, discharge, release or escape of any contaminants, irritants, or pollutants in or on land, the atmosphere, or any water course of body of water, provided this results in environmental damage.

There shall be no cancellation, material change, reduction of limits or intent not to renew the insurance coverage(s) without sixty (60) days written notice from the Company or its insurer(s) to the City. As evidence of the insurance coverage(s) required by this Agreement, the Company shall furnish acceptable Certificates Of Insurance (COI) to the City at the time it returns this signed Agreement. The certificate shall specify the City of Spokane as "Additional Insured" specifically for Company's services under this Agreement, as well as all of the parties who are additional insureds, and include applicable policy endorsements, the sixty (60) day cancellation clause, and the deduction or retention level. The Company shall be financially responsible for all pertinent deductibles, self-insured retentions, and/or self-insurance.

## **10. DEBARMENT AND SUSPENSION.**

The Company has provided its certification that it is in compliance with and shall not contract with individuals or organizations which are debarred, suspended, or otherwise excluded from or ineligible from participation in Federal Assistance Programs under Executive Order 12549 and "Debarment and Suspension", codified at 29 CFR part 98 (see Exhibit A).

**11. AUDIT.**

The Company and its subcontractor shall maintain for a minimum of three (3) years following final payment all records related to its performance of the Agreement. The Company and its subcontractors shall provide access to authorized City representatives, at reasonable times and in a reasonable manner to inspect and copy any such record. In the event of conflict between this provision and related auditing provisions required under federal law applicable to the Agreement, the federal law shall prevail.

**12. KEY PERSONS.**

The Company shall not transfer or reassign any individual designated in this Agreement as essential to the Work, nor shall those key persons, or employees of Company identified as to be involved in the Project Work be replaced, removed or withdrawn from the Work without the express written consent of the City, which shall not be unreasonably withheld. If any such individual leaves the Company's employment, the Company shall present to the City one or more individuals with greater or equal qualifications as a replacement, subject to the City's approval, which shall not be unreasonably withheld. The City's approval does not release the Company from its obligations under this Agreement.

**13. ASSIGNMENT AND SUBCONTRACTING.**

The Company shall not assign or subcontract its obligations under this Agreement without the City's written consent, which may be granted or withheld in the City's sole discretion. Any subcontract made by the Company shall incorporate by reference this Agreement, except as otherwise provided. The Company shall ensure that all subcontractors comply with the obligations and requirements of the subcontract. The City's consent to any assignment or subcontract does not release the Company from liability or any obligation within this Agreement, whether before or after City consent, assignment or subcontract.

**14. TERMINATION.**

Either party may terminate this Agreement, with or without cause, by ten (10) days written notice to the other party. In the event of such termination, the City shall pay the Company for all work previously authorized and performed prior to the termination date.

**15. STANDARD OF PERFORMANCE.**

The standard of performance applicable to Company's services will be the degree of skill and diligence normally employed by professional Companies performing the same or similar services at the time the services under this Agreement are performed.

**16. OWNERSHIP AND USE OF RECORDS AND DOCUMENTS.**

Original documents, drawings, designs, reports, or any other records developed or created under this Agreement shall belong to and become the property of the City. All records submitted by the City to the Company shall be safeguarded by the Company. The Company shall make such data, documents and files available to the City upon the City's request. If the City's use of the Company's records or data is not related to this project, it shall be without liability or legal exposure to the Company.

Under Washington State Law (reference RCW Chapter 42.56, the *Public Records Act* [PRA]) all materials received or created by the City of Spokane are **public records** and are available to the public for viewing via the City Clerk's Records (online) or a valid Public Records Request (PRR).

**17. ANTI KICK-BACK.**

No officer or employee of the City of Spokane, having the power or duty to perform an official act or action related to this Agreement shall have or acquire any interest in the Agreement, or have solicited, accepted or granted a present or future gift, favor, service or other thing of value from or to any person involved in this Agreement.

**18. MISCELLANEOUS PROVISIONS.**

- A. **Amendments/Modifications:** This Agreement may be modified by the City in writing when necessary, and no modification or Amendment of this Agreement shall be effective unless signed by an authorized representative of each of the parties hereto.
- B. The Company, at no expense to the City, shall comply with all laws of the United States and Washington, the Charter and ordinances of the City of Spokane; and rules, regulations, orders and directives of their administrative agencies and officers. Without limiting the generality of this paragraph, the Company shall comply with the requirements of this Section.
- C. This Agreement shall be construed and interpreted under the laws of Washington. The venue of any action brought shall be in a court of competent jurisdiction, located in Spokane County, Washington.
- D. **Captions:** The titles of sections or subsections are for convenience only and do not define or limit the contents.
- E. **Severability:** If any term or provision is determined by a court of competent jurisdiction to be invalid or unenforceable, the remainder of this Agreement shall not be affected, and each term and provision shall be valid and enforceable to the fullest extent permitted by law.
- F. **Waiver:** No covenant, term or condition or the breach shall be deemed waived, except by written consent of the party against whom the waiver is claimed, and any waiver of the breach of any covenant, term or condition shall not be deemed a waiver of any preceding or succeeding breach of the same or any other covenant, term of condition. Neither the acceptance by the City of any performance by the Company after the time the same shall have become due nor payment to the Company for any portion of the Work shall constitute a waiver by the City of the breach or default of any covenant, term or condition unless otherwise expressly agreed to by the City in writing.
- G. **Entire Agreement:** This document along with any exhibits and all attachments, and subsequently issued addenda, comprises the entire agreement between the City and the Firm. If conflict occurs between Agreement documents and applicable laws, codes, ordinances or regulations, the most stringent or legally binding requirement shall govern and be considered a part of this Agreement to afford the City the maximum benefits.
- H. **No personal liability:** No officer, agent or authorized employee of the City shall be personally responsible for any liability arising under this Agreement, whether expressed or implied, nor for any statement or representation made or in any connection with this Agreement.

IN WITNESS WHEREOF, in consideration of the terms, conditions and covenants contained, or attached and incorporated and made a part, the parties have executed this Agreement by having legally-binding representatives affix their signatures below.

**CIRCLE M CONSTRUCTION AND  
LANDSCAPE SUPPLIES INC.**

**CITY OF SPOKANE**

By \_\_\_\_\_  
Signature Date

By \_\_\_\_\_  
Signature Date

\_\_\_\_\_  
Type or Print Name

\_\_\_\_\_  
Type or Print Name

\_\_\_\_\_  
Title

\_\_\_\_\_  
Title

Attest:

Approved as to form:

\_\_\_\_\_  
City Clerk

\_\_\_\_\_  
Assistant City Attorney

**Attachments that are part of this Agreement:**

Exhibit A – Certificate Regarding debarment

Exhibit B – Circle M Construction and Landscape Supplies Inc – Bid Response Summary dated September 25, 2024.

24-194

**EXHIBIT A**

**CERTIFICATION REGARDING DEBARMENT, SUSPENSION,  
INELIGIBILITY AND VOLUNTARY EXCLUSION**

1. The undersigned (i.e., signatory for the Subrecipient / Contractor / Consultant) certifies, to the best of its knowledge and belief, that it and its principals:
  - a. Are not presently debarred, suspended, proposed for debarment, declared ineligible, or voluntarily excluded from covered transactions by any federal department or agency;
  - b. Have not within a three-year period preceding this contract been convicted or had a civil judgment rendered against them for commission of fraud or a criminal offense in connection with obtaining, attempting to obtain, or performing a public (federal, state, or local) transaction or contract under a public transaction; violation of federal or state antitrust statutes or commission of embezzlement, theft, forgery, bribery, falsification or destruction of records, making false statements, tax evasion, receiving stolen property, making false claims, or obstruction of justice;
  - c. Are not presently indicted or otherwise criminally or civilly charged by a government entity (federal, state, or local) with commission of any of the offenses enumerated in paragraph (1)(b) of this certification; and,
  - d. Have not within a three-year period preceding this contract had one or more public transactions (federal, state, or local) terminated for cause or default.
  
2. The undersigned agrees by signing this contract that it shall not knowingly enter into any lower tier covered transaction with a person who is debarred, suspended, declared ineligible, or voluntarily excluded from participation in this covered transaction.
  
3. The undersigned further agrees by signing this contract that it will include the following clause, without modification, in all lower tier covered transactions and in all solicitations for lower tier covered transactions:

Certification Regarding Debarment, Suspension, Ineligibility and Voluntary Exclusion – Lower Tier Covered Transactions

1. The lower tier contractor certified, by signing this contract that neither it nor its principals is presently debarred, suspended, proposed for debarment, declared ineligible, or voluntarily excluded from participation in this transaction by any federal department or agency.
  
2. Where the lower tier contractor is unable to certify to any of the statements in this contract, such contractor shall attach an explanation to this contract.
  
4. I understand that a false statement of this certification may be grounds for termination of the contract.

Name of Subrecipient / Contractor / Consultant (Type or Print)	Program Title (Type or Print)
Name of Certifying Official (Type or Print)	Signature
Title of Certifying Official (Type or Print)	Date (Type or Print)

**EXHIBIT B**





< Business Lookup

### License Information:

[New search](#) [Back to results](#)

**Entity name:** CIRCLE M CONSTRUCTION & LANDSCAPE SUPPLIES, INC.

**Business name:** CIRCLE M CONSTRUCTION & LANDSCAPE SUPPLIES INC

**Entity type:** [Profit Corporation](#)

**UBI #:** 603-087-746

**Business ID:** 001

**Location ID:** 0001

**Location:** Active

**Location address:** 1820 N UNIVERSITY RD  
SPOKANE VALLEY WA 99206-6378

**Mailing address:** 1820 N UNIVERSITY RD  
SPOKANE VALLEY WA 99206-6378

**Excise tax and reseller permit status:** [Click here](#)

**Secretary of State status:** [Click here](#)

### Endorsements

Endorsements held at this location	License #	Count	Details	Status	Expiration date	First issuance date
<a href="#">Spokane General Business - Non-Resident</a>				Active	Feb-28-2025	Oct-23-2013
<a href="#">Spokane Valley General Business</a>				Active	Feb-28-2025	Apr-09-2021

### Governing People May include governing people not registered with Secretary of State

Governing people	Title
MICHIELLI III, PATRICK	
MICHIELLI, BRANDON	
MICHIELLI, TERESA	

### Registered Trade Names

Registered trade names	Status	First issued
CIRCLE M CONSTRUCTION & LANDSCAPE SUPPLIES INC.	Active	Oct-23-2013

[View Additional Locations](#)

The Business Lookup information is updated nightly. Search date and time: 9/30/2024 11:04:04 AM

[Contact us](#)

How are we doing?  
[Take our survey!](#)

Don't see what you expected?  
[Check if your browser is supported](#)



< Business Lookup

### License Information:

[New search](#) [Back to results](#)

**Entity name:** CIRCLE M CONSTRUCTION & LANDSCAPE SUPPLIES, INC.

**Business name:** CIRCLE M CONSTRUCTION & LANDSCAPE SUPPLIES INC

**Entity type:** [Profit Corporation](#)

**UBI #:** 603-087-746

**Business ID:** 001

**Location ID:** 0001

**Location:** Active

**Location address:** 1820 N UNIVERSITY RD  
SPOKANE VALLEY WA 99206-6378

**Mailing address:** 1820 N UNIVERSITY RD  
SPOKANE VALLEY WA 99206-6378

**Excise tax and reseller permit status:** [Click here](#)

**Secretary of State status:** [Click here](#)

### Endorsements

Endorsements held at this location	License #	Count	Details	Status	Expiration date	First issuance date
<a href="#">Spokane General Business - Non-Resident</a>				Active	Feb-28-2025	Oct-23-2013
<a href="#">Spokane Valley General Business</a>				Active	Feb-28-2025	Apr-09-2021

### Governing People May include governing people not registered with Secretary of State

Governing people	Title
MICHIELLI III, PATRICK	
MICHIELLI, BRANDON	
MICHIELLI, TERESA	

### Registered Trade Names

Registered trade names	Status	First issued
CIRCLE M CONSTRUCTION & LANDSCAPE SUPPLIES INC.	Active	Oct-23-2013

[View Additional Locations](#)

The Business Lookup information is updated nightly. Search date and time: 9/30/2024 11:04:04 AM

[Contact us](#)

How are we doing?  
[Take our survey!](#)

Don't see what you expected?  
[Check if your browser is supported](#)



# CERTIFICATE OF LIABILITY INSURANCE

DATE (MM/DD/YYYY)  
10/07/2024

THIS CERTIFICATE IS ISSUED AS A MATTER OF INFORMATION ONLY AND CONFERS NO RIGHTS UPON THE CERTIFICATE HOLDER. THIS CERTIFICATE DOES NOT AFFIRMATIVELY OR NEGATIVELY AMEND, EXTEND OR ALTER THE COVERAGE AFFORDED BY THE POLICIES BELOW. THIS CERTIFICATE OF INSURANCE DOES NOT CONSTITUTE A CONTRACT BETWEEN THE ISSUING INSURER(S), AUTHORIZED REPRESENTATIVE OR PRODUCER, AND THE CERTIFICATE HOLDER.

**IMPORTANT:** If the certificate holder is an ADDITIONAL INSURED, the policy(ies) must have ADDITIONAL INSURED provisions or be endorsed. If SUBROGATION IS WAIVED, subject to the terms and conditions of the policy, certain policies may require an endorsement. A statement on this certificate does not confer rights to the certificate holder in lieu of such endorsement(s).

<b>PRODUCER</b> FEDERATED MUTUAL INSURANCE COMPANY HOME OFFICE: P.O. BOX 328 OWATONNA, MN 55060	<b>CONTACT NAME:</b> CLIENT CONTACT CENTER	
	<b>PHONE (A/C, No, Ext):</b> 888-333-4949	<b>FAX (A/C, No):</b> 507-446-4664
<b>E-MAIL ADDRESS:</b> CLIENTCONTACTCENTER@FEDINS.COM		
<b>INSURERS AFFORDING COVERAGE</b>		<b>NAIC #</b>
<b>INSURER A:</b> FEDERATED RESERVE INSURANCE COMPANY		16024
<b>INSURER B:</b>		
<b>INSURER C:</b>		
<b>INSURER D:</b>		
<b>INSURER E:</b>		
<b>INSURER F:</b>		

<b>COVERAGES</b>	<b>CERTIFICATE NUMBER: 5</b>	<b>REVISION NUMBER: 0</b>
------------------	------------------------------	---------------------------

THIS IS TO CERTIFY THAT THE POLICIES OF INSURANCE LISTED BELOW HAVE BEEN ISSUED TO THE INSURED NAMED ABOVE FOR THE POLICY PERIOD INDICATED. NOTWITHSTANDING ANY REQUIREMENT, TERM OR CONDITION OF ANY CONTRACT OR OTHER DOCUMENT WITH RESPECT TO WHICH THIS CERTIFICATE MAY BE ISSUED OR MAY PERTAIN, THE INSURANCE AFFORDED BY THE POLICIES DESCRIBED HEREIN IS SUBJECT TO ALL THE TERMS, EXCLUSIONS AND CONDITIONS OF SUCH POLICIES. LIMITS SHOWN MAY HAVE BEEN REDUCED BY PAID CLAIMS.

INSR LTR	TYPE OF INSURANCE	ADDL INSR	SUBR WVD	POLICY NUMBER	POLICY EFF (MM/DD/YYYY)	POLICY EXP (MM/DD/YYYY)	LIMITS	
A	<input checked="" type="checkbox"/> COMMERCIAL GENERAL LIABILITY	Y	N	1895326	04/26/2024	04/26/2025	EACH OCCURRENCE	\$1,000,000
	<input type="checkbox"/> CLAIMS-MADE <input checked="" type="checkbox"/> OCCUR						DAMAGE TO RENTED PREMISES (Ea occurrence)	\$100,000
							MED EXP (Any one person)	EXCLUDED
							PERSONAL & ADV INJURY	\$1,000,000
							GENERAL AGGREGATE	\$2,000,000
GENL AGGREGATE LIMIT APPLIES PER:							PRODUCTS & COMP/OP ACC	\$2,000,000
	<input checked="" type="checkbox"/> POLICY <input type="checkbox"/> PRO-JECT <input type="checkbox"/> LOC							
	OTHER:							
A	AUTOMOBILE LIABILITY	N	N	1895326	04/26/2024	04/26/2025	COMBINED SINGLE LIMIT (Ea accident)	\$1,000,000
	<input checked="" type="checkbox"/> ANY AUTO						BODILY INJURY (Per Person)	
	<input type="checkbox"/> OWNED AUTOS ONLY <input type="checkbox"/> SCHEDULED AUTOS						BODILY INJURY (Per Accident)	
	<input type="checkbox"/> HIRED AUTOS OWNLY <input type="checkbox"/> NON-OWNED AUTOS ONLY						PROPERTY DAMAGE (Per Accident)	
A	<input checked="" type="checkbox"/> UMBRELLA LIAB <input checked="" type="checkbox"/> OCCUR	N	N	1895327	04/26/2024	04/26/2025	EACH OCCURRENCE	\$3,000,000
	<input type="checkbox"/> EXCESS LIAB <input type="checkbox"/> CLAIMS-MADE						AGGREGATE	\$3,000,000
	DED <input type="checkbox"/> RETENTION <input type="checkbox"/>							
A	WORKERS COMPENSATION AND EMPLOYERS' LIABILITY	N/A	N	1895326	04/26/2024	04/26/2025	<input type="checkbox"/> Y <input type="checkbox"/> N	
	ANY PROPRIETOR/PARTNER/ EXECUTIVE OFFICER/MEMBER EXCLUDED? (Mandatory in NH)						PER STATUTE	OTHER
	If yes, describe under DESCRIPTION OF OPERATIONS below						E.L EACH ACCIDENT	\$1,000,000
							E.L DISEASE EA EMPLOYEE	\$1,000,000
							E.L DISEASE POLICY LIMIT	\$1,000,000

DESCRIPTION OF OPERATIONS / LOCATIONS / VEHICLES (ACORD 101, Additional Remarks Schedule, may be attached if more space is required)  
**SEE ATTACHED PAGE**

<b>CERTIFICATE HOLDER</b> CITY OF SPOKANE SOLID WASTE DISPOSAL 808 W SPOKANE FALLS BLVD SPOKANE, WA 99201-3301	<b>CANCELLATION</b> SHOULD ANY OF THE ABOVE DESCRIBED POLICIES BE CANCELLED BEFORE THE EXPIRATION DATE THEREOF, NOTICE WILL BE DELIVERED IN ACCORDANCE WITH THE POLICY PROVISIONS.  AUTHORIZED REPRESENTATIVE  
---	---



AGENCY CUSTOMER ID: \_\_\_\_\_

LOC #: \_\_\_\_\_

**ADDITIONAL REMARKS SCHEDULE**

Page 1 of 1

AGENCY FEDERATED MUTUAL INSURANCE COMPANY		NAMED INSURED CIRCLE M CONSTRUCTION & LANDSCAPE SUPPLIES, INC. 1820 N UNIVERSITY RD SPOKANE VALLEY, WA 99206-6378	
POLICY NUMBER SEE CERTIFICATE # 5.0			
CARRIER SEE CERTIFICATE # 5.0	NAIC CODE	EFFECTIVE DATE: SEE CERTIFICATE # 5.0	

**ADDITIONAL REMARKS**

THIS ADDITIONAL REMARKS FORM IS A SCHEDULE TO ACORD FORM,

FORM NUMBER: 25 FORM TITLE: CERTIFICATE OF LIABILITY INSURANCE

ADDITIONAL NAMED INSUREDS INCLUDE  
CIRCLE M LANDSCAPE SUPPLY

STOP-GAP (EMPLOYER'S LIABILITY) COVERED STATE(S) WA

RFQ 5237-24

PROJECT: SOLID WASTE DISPOSAL, WASTE TO ENERGY FACILITY (COS WTE) 2900 S GEIGER BLVD SPOKANE, WA 99224  
SUBJECT TO THE TERMS AND CONDITIONS OF THE POLICY, ADDITIONAL INSUREDS ALSO INCLUDES CITY, ITS OFFICERS AND EMPLOYEES.

THE CERTIFICATE HOLDER IS AN ADDITIONAL INSURED ON GENERAL LIABILITY SUBJECT TO THE CONDITIONS OF THE ADDITIONAL INSURED - DESIGNATED PERSON OR ORGANIZATION ENDORSEMENT.

**THIS ENDORSEMENT CHANGES THE POLICY. PLEASE READ IT CAREFULLY.**

**ADDITIONAL INSURED - DESIGNATED  
PERSON OR ORGANIZATION**

This endorsement modifies insurance provided under the following:

COMMERCIAL GENERAL LIABILITY COVERAGE PART

**SCHEDULE**

Name Of Additional Insured Person(s) Or Organization(s):	DESCRIPTION OF INTEREST IF APPLICABLE:
City of Spokane Solid Waste Disposal 808 W Spokane Falls Blvd Spokane, WA 99201-3301	See IL-F-40-00001

Information required to complete this Schedule, if not shown above, will be shown in the Declarations.

**A. Section II - Who Is An Insured** is amended to include as an additional insured the person(s) or organization(s) shown in the Schedule, but only with respect to liability for "bodily injury", "property damage" or "personal and advertising injury" caused, in whole or in part, by your acts or omissions or the acts or omissions of those acting on your behalf:

1. In the performance of your ongoing operations; or
2. In connection with your premises owned by or rented to you.

However:

1. The insurance afforded to such additional insured only applies to the extent permitted by law; and
2. If coverage provided to the additional insured is required by a contract or agreement, the insurance afforded to such additional insured will not be broader than that which you are required by the contract or agreement to provide for such additional insured.

**B.** With respect to the insurance afforded to these additional insureds, the following is added to **Section III - Limits Of Insurance:**

If coverage provided to the additional insured is required by a contract or agreement, the most we will pay on behalf of the additional insured is the amount of insurance:

1. Required by the contract or agreement; or
2. Available under the applicable limits of insurance;

whichever is less.

This endorsement shall not increase the applicable limits of insurance.

**Insured:**

CIRCLE M CONSTRUCTION & LANDSCAPE SUPPLIES, INC.  
1820 N University Rd  
Spokane Valley, WA 99206-6378

**IL-F-40-00001 Extension Endorsement**

Any coverage provided by this endorsement applies only to delivery of Topsoil to American Recycling Corp. located at 6203 E. Mission Ave. to Northside Landfill located at 7202 Nine Mile Rd. Subject to the terms and conditions of the policy, Additional Insureds also includes City, its officers and employees.

### Bid Response Summary

**Bid Number** RFQ 6237-24  
**Bid Title** Dump Truck Services for Transport of Topsoil  
**Due Date** Wednesday, September 25, 2024 9:00:00 AM [(UTC-08:00) Pacific Time (US & Canada)]  
**Bid Status** Open for Bidding  
**Company** Circle M Construction and Landscape Supply Inc.  
**Submitted By** Mark Townsend - Tuesday, September 24, 2024 1:02:49 PM [(UTC-08:00) Pacific Time (US & Canada)]  
 mptpepsi@yahoo.com 5098903910

**Comments**

**Question Responses**

Group	Reference Number	Question	Response
BACKGROUND			
	#1	The City of Spokane, Solid Waste Disposal, Waste To Energy Facility (COS WTE), is located at 2900 S. Geiger Blvd, Spokane WA 99224-5400. COS WTEF operates a 24-hour/365 day per year environment and works under aggressive deadlines and schedules that require vendors to provide high service levels. COS WTEF is initiating this Invitation To Bid to solicit Bids from vendors who have a proven ability to provide Dump Truck Services for Transport of Topsoil.	Acknowledged
BID SUBMISSION			
	#1	Bid Responses shall be submitted electronically through the City of Spokane's bidding portal: <a href="https://spokane.procureware.com">https://spokane.procureware.com</a> on or before the Due Date and time mentioned above. Hard, e-mailed or faxed copies and/or late bids shall not be accepted.	Acknowledged
	#2	The City of Spokane is not responsible for bids electronically submitted late. It is the responsibility of the Bidder to be sure the bids are electronically submitted sufficiently ahead of time to be received no later than 1:00 p.m. Pacific Local Time, on the bid due date.	Acknowledged
	#3	All communication between the Bidder and the City upon receipt of this bid shall be via the "Clarification Tab" within ProcureWare. Any other communication will be considered unofficial and non-binding on the City	Acknowledged
INTERPRETATION			

<p>#1</p>	<p>If the Bidder discovers any errors, discrepancies, or omissions in the Bid specifications, or has any questions about the specifications, the Bidder must notify Purchasing in writing. Any addenda issued by the Purchaser will be incorporated into the contract or purchase order.</p>	<p>I agree and I acknowledge</p>
<p>WITHDRAWAL OF QUOTES</p>		
<p>#1</p>	<p>Bidders may quote prior to the scheduled bid due date. Unless otherwise specified, no Bids may be withdrawn for a minimum of ninety (90) calendar days after the bid due date.</p>	<p>I agree and I acknowledge</p>
<p>EVALUATIONS OF BIDS</p>		
<p>1</p>	<p>Evaluation of Quotes Shall be based upon the following criteria, where applicable: A. The price, including sales tax and the effect of discounts. Price may be determined by life cycle costing or total cost quoting, when advantageous to the Purchaser. B. The quality of the items quoted, their conformity to specifications and the purpose for which they are required. C. The Bidder's ability to provide prompt and efficient service and/or delivery. D. The character, integrity, reputation, judgment, experience and efficiency of the Bidder. E. The quality of performance of previous contracts or services. F. The previous and existing compliance by the Bidder with the laws relating to the contract or services. G. Uniformity or interchangeability. H. The energy efficiency of the product throughout its life. I. Any other information having a bearing on the decision to award the contract.</p>	<p>Acknowledged</p>
<p>QUOTING ERRORS</p>		
<p>#1</p>	<p>Unit pricing will prevail in the circumstance of unit and extension pricing discrepancies. When, after the opening and tabulation of Bids, a Bidder claims error, and requests to be relieved of award, he will be required to promptly present certified work sheets. The Purchaser will review the work sheets and if the Purchaser is convinced, by clear and convincing evidence, that an honest, mathematically excusable error or critical omission of costs has been made, the Bidder may be relieved of his Bid.</p>	<p>I acknowledge and I understand</p>



REJECTION OF QUOTES		
#1	The Purchaser reserves the right to reject any or all Bids; to waive minor deviations from the specifications, to waive any informality in bids received, whenever it is in the Purchaser's best interest, and to accept or reject all or part of this Bid at prices shown.	I agree and I acknowledge
AWARD OF CONTRACT		
#1	Award of contract or purchase, when made, will be to the Bidder whose Bid is the most favorable to the Purchaser, taking into consideration price and the other evaluation factors. STATE CONTRACTS WHERE APPLICABLE WILL BE CONSIDERED AS A BID. The City Council shall make the award of contract or purchase. Unsuccessful Bidders will not automatically be notified of Bid results.	I agree and I acknowledge
PAYMENT TERMS		
#1	Payment shall be made Net 30 via direct deposit/ACH (except as provided by state law) according to terms after receipt of the goods/services delivered and accepted. A completed ACH application is required before a City order will be issued. If the City objects to all or any portion of an invoice, it shall notify the supplier and reserve the right to pay only that portion of the invoice not in dispute. In that event, all parties shall immediately make every effort to settle the disputed amount.	I agree and I acknowledge
INVOICING		
#1	Invoices must be submitted to Spokane Solid Waste Disposal within 30 days of a transport. • All Invoices shall include OPR Contract Number, Copies of Weigh Tickets, for Quantity of Tons Transported that are being invoiced per Unit Pricing per Contract. • Payment of invoices shall be contingent upon receipt of sufficient detail to permit identification of the transported tons, and compliance with contract conditions. Original invoices are required and shall not be approved for payment until all required support is provided. Invoices shall be emailed to mdorgan@spokanecity.org.	I agree and I acknowledge
TERMS AND CONDITIONS		

#1	Bidder acknowledges that they have read and understand the Terms and Conditions Document in the "Documents" tab. If answer is "I don't agree and I don't acknowledge", include requested exception in proposal submittal on separate page and title as "Exception to Terms and Conditions". The City will consider and determine if exception will be accepted.	I agree and I acknowledge
#1.2	EXCEPTION: If you took exception above, upload here.	
#2	ELIGIBILITY FOR CITY CONTRACTS: Section 18.09.050 of the Spokane Municipal Code states that the recipient of a City contract, award or purchase order shall certify that it is not knowingly or intentionally a nuclear weapons producer. The Bidder certifies that his/her firm is not a nuclear weapons producer.	I certify
<b>BIDDER INFORMATION</b>		
#1	Please indicate the appropriate point of contact (including phone number and email) regarding this Bid and placement of orders if awarded. If these actions will not be managed by the same person, please explicitly specify all relevant contacts.	Mark Townsend 509-890-3910 mptpepsi@yahoo.com Brandon Michielli brandon@spokanelandscape.net
<b>ORGANIZATION</b>		
#1	Organization: Bidder Should Enter If Proposal Is of an Individual, Partnership, Corporation, and Existing Under The Laws of What US State. Enter Information Here	Corporation
<b>BUSINESS REGISTRATION:</b>		
1	Section 8.01.070 of the Spokane Municipal Code states that no person may engage in business with the City without first having obtained and being the holder of a valid annual business registration or temporary business registration as provided in this chapter. The supplier shall be responsible for contacting the State of Washington Business License Services at <a href="http://bls.dor.wa.gov">http://bls.dor.wa.gov</a> or 1-360-705-6741 to obtain a business registration. If the supplier does not believe it is required to obtain a business registration, it may contact the City's Taxes and Licenses Division at 509-625-6070 to request an exemption status determination.	I agree and I acknowledge
2	City of Spokane Business Registration Number:	603-087-746

<p>PROPRIETARY INFORMATION/PUBLIC DISCLOSURE</p>		
1	<p>Materials submitted in response to this competitive procurement shall become the property of the City. All received Proposals shall remain confidential until the award of contract recommendation has been filed with the applicable Council Committee or the City Clerk for City Council action. Thereafter, the Proposals shall be deemed public records as defined in RCW 42.56, "Public Records." Any information in the Proposal that the Proposer desires to claim as proprietary and thus exempt from disclosure under the provisions of existing state law, shall be clearly designated. Each page claimed to be exempt from disclosure must be clearly identified by the word "Confidential" printed on it. Marking the entire Proposal exempt from disclosure will not be honored. The City will consider a Proposer's request for exemption from disclosure; however, the City will make a decision predicated upon state law and regulations. If any information is marked as proprietary in the Proposal, it will not be made available until the affected Proposer has been given an opportunity to seek a court injunction against the requested disclosure.</p>	I agree and I acknowledge
<p>BIDDER PREQUALIFICATION</p>		
#1	<p>Prior to award of contract or purchase, Bidders shall be required to submit evidence of sufficient facilities, equipment, experience and financial ability to insure completion of the work, unless waived by the COS WTEF.</p>	I agree and I acknowledge
<p>INSURANCE</p>		
1	<p>INSURANCE. During the period of the Agreement, the Company shall maintain in force at its own expense, each insurance noted below with companies or through sources approved by the State Insurance Commissioner pursuant to Title 48 RCW:</p>	I agree and I acknowledge

2	A. Worker's Compensation Insurance in compliance with RCW 51.12.020 which requires subject employers to provide worker's compensation coverage for all their subject workers and Employer's Liability Insurance in the amount of \$1,000,000.00.	I agree and I acknowledge
3	B. General Liability Insurance on an occurrence basis, with a combined single limit of not less than \$1,000,000 each occurrence for bodily injury and property damage. It shall include contractual liability coverage for the indemnity provided under this Agreement. It shall provide that the City, its officers and employees are additional insureds but only with respect to the Company's services to be provided under this Agreement	I agree and I acknowledge
#3.1	i. Acceptable supplementary Umbrella insurance coverage combined with Company's General Liability insurance policy must be a minimum of \$1,000,000, in order to meet the insurance coverage limits required in this Agreement; and	I agree and I acknowledge
4	C. Automobile Liability Insurance with a combined single limit, or the equivalent of not less than \$1,000,000 each accident for bodily injury and property damage, including coverage for owned, hired and non-owned vehicles.	I agree and I acknowledge
5	D. Pollution Legal Liability Insurance with a minimum coverage for Bodily Injury and Property Damage of not less than \$1,000,000 per occurrence and \$3,000,000 aggregate. Pollution Liability covers sums the Operator is legally obligated to pay as a result of emission, discharge, release, or escape of any contaminants, irritants, or pollutants in or on land, the atmosphere, or any water course or body of water, provided this results in environmental damage.	I agree and I acknowledge

6	<p>There shall be no cancellation, material change, reduction of limits or intent not to renew the insurance coverage(s) without thirty (30) days written notice from the Company or its insurer(s) to the City. As evidence of the insurance coverage(s) required by this Agreement, the Company shall furnish acceptable Certificates of Insurance (COI) upon request by the City. The certificate shall specify the City of Spokane as "Additional Insured" specifically for Company's services under this Agreement, as well as all of the parties who are additional insureds, and include applicable policy endorsements, the thirty (30) day cancellation clause, and the deduction or retention level. The Company shall be financially responsible for all pertinent deductibles, self-insured retentions, and/or self-insurance</p>	I agree and I acknowledge
<b>MINORITY BUSINESS ENTERPRISE</b>		
#1	<p>Vendor ( IS ) ( IS NOT ) a Minority Business Enterprise. A Minority Business Enterprise is defined as a "business, privately or publicly owned, at least 51% of which is owned by minority group members." For purpose of this definition, minority group members are Blacks, Hispanics, Asian Americans, American Indian or Alaskan Natives, or Women.</p>	Is Not
<b>SMALL BUSINESS</b>		
#1	<p>Vendor ( IS ) ( IS NOT ) a small business concern. (A small business concern for the purpose of government procurement is a concern, including its affiliates, which is independently owned and operated, is not dominant in the field of operations in which it is bidding on government contracts, and can further qualify under the criteria concerning number of employees, average annual receipts, or other criteria as prescribed by the Small Business Administration).</p>	Is Not
<b>NON-COLLUSION</b>		
#1	<p>The Bidder certifies that his/her firm has not entered into any agreement of any nature whatsoever to fix, maintain, increase, or reduce the prices or competition regarding the items covered by this Bid invitation.</p>	Certifies No Agreement Has Been Entered

ACCEPTANCE PERIOD		
#1	Bids must provide a minimum of ninety (90) calendar days for acceptance by the City from the bid due date.	I agree and I acknowledge
CONTRACT RENEWALS		
#1	Contract renewals or extensions shall be initiated at the discretion of the City and subject to mutual agreement. Resulting contract may be extended for two (2) additional one-year contract periods with the total contract period not to exceed three (3) years. Annual Price increases must be submitted to the City for approval. The City may require backup documentation for such price increase.	I agree and I acknowledge
TERM OF CONTRACT		
1	Upon City Council approval, the Contract resulting from this RFQ will be for a one-year period, beginning approximately November 15, 2024, and terminate on November 14, 2025. The Vendor's prices shall be firm throughout the first year.	I agree and I acknowledge
GENERAL INSTRUCTIONS		
#2	Time is of the essence in the performance of this contract.	I agree and I acknowledge
#3	Successful bidder will designate a representative who will be available during regular City business hours to serve as a primary contact for the City if any issues arise regarding service.	I agree and I acknowledge
#4	The City of Spokane reserves the right to accept or reject any variance from the published requirements and to award the Bid in a manner that is most advantageous to the continued efficient operation of the City.	I agree and I acknowledge
#5	The City reserves the right to accept or reject any part of or all Bids, and to accept the Bid deemed to be in the best interest of the City.	I agree and I acknowledge
#6	The City may choose from more than one vendor. The City of Spokane reserves the option of awarding by type or grouping, or by any manner most advantageous for the City.	I agree and I acknowledge
#7	Bidder should be aware that Bids may be rejected if all questions are not completely and correctly answered.	I agree and I acknowledge

TECHNICAL REQUIREMENTS		
#1	Performance Unless otherwise stated, the Vendor will be responsible for the furnishing of all labor, supervision, materials, tools, construction equipment, transportation, and other items of work and costs necessary for the proper performance and completion of the described Work. The apparent silence or omission as to any detail of any Work to be done or materials to be furnished and required for the proper performance of the Work, shall be regarded as meaning that the best general practice is to prevail, and that material and workmanship of the best quality are to be used, and interpretation of the scope of work shall be made upon this basis.	I agree and I acknowledge
#2	Scope of Work The scope of Services will include, but is not limited to, the following:	Yes
#2.1	Awarded vendor shall provide topsoil transport from American Recycling Corp., 6203 E. Mission Ave, Spokane Valley, WA 99212 to Northside Landfill, 7202 Nine Mile Road, Spokane, WA 99208.	I agree and I acknowledge
#2.2	Topsoil is expected to be contaminated with garbage debris intermixed. No testing data is available regarding topsoil.	I agree and I acknowledge
#2.2.1	The Northside Landfill will use the topsoil as ground cover.	I agree and I acknowledge
#2.3	The Vendor shall have 12yd to 15yd rear dump box tandem axle trucks, with Pup Trailers to be able to transport 18 tons per each transport.	I agree and I acknowledge
#2.4	American Recycling will be responsible for loading Vendor's vehicles.	I agree and I acknowledge
#2.5	Vendor must ensure all load are tarped, prior to transporting.	I agree and I acknowledge
#2.6	Vendor shall ensure a weight ticket it submitted for each transport being invoiced. Load Tickets must be obtained from American Recycling.	I agree and I acknowledge
#2.7	Vendor will only be paid for actual tons transported, based on contract's all-inclusive-transported-cost-per-ton, supported by weigh tickets.	I agree and I acknowledge
#2.8	EXCEPTIONS If you marked "I do not acknowledge and agree" on any of the areas above, explain here what you are taking exception to.	
TRANSPORTS		

#1	SERVICE SCHEDULE: Vendor shall be responsible for coordinating deliveries with American Recycling and COS WTEF, Vendor is responsible to ensure minimum load weights are met. It is expected that transports are to occur between the hours of 6:00AM - 3:00PM, during weekdays of Monday, Tuesday, Wednesday, and Thursday. The COS WTEF retains the right to change time frames and weekdays.	I agree and I acknowledge
#1.1	Quantities shown are estimates only and are not guaranteed. Actual usage may be more or less.	I agree and I acknowledge
#1.2	Each transport is estimated to be 18 Tons.	I agree and I acknowledge
#1.3	Annual Estimated Quantity is 3,640 tons, equating to 200 transports, with each transport being 18 tons. Payment would only be made for actual transports performed supported by weigh tickets, throughout the term of Contract and any renewals.	I agree and I acknowledge
#2	Successful Vendor must use high quality, safe equipment and operating procedures.	I agree and I acknowledge
#3	DELIVERY - F.O.B. POINT: Transferred and unloaded at designated location at the Northside Landfill, 7202 Nine Mile Road, Spokane, WA 99208.	I agree and I acknowledge
#3.1	Vendor will be held responsible to comply with the established receiving program.	I agree and I acknowledge
#3.2	Vendor shall adhered to All WTEF Safety procedures shall be while on WTEF premises.	I agree and I acknowledge
DELIVERY DEFAULT		
#1	The acceptance of late performance by the Purchaser shall not waive the right to claim damage for such breach nor constitute a waiver of the requirements for the timely performance of any obligations remaining to be performed by Vendor.	I agree and I acknowledge
#2	Purchaser may procure from another source and Vendor will be required to pay any differences in cost.	I agree and I acknowledge
PRICING		
#1	Sales Tax: The City of Spokane is not a tax exempt entity and is therefore obligated to pay sales tax under Washington State law. Sales tax should --not-- be included in bidder's unit pricing. All submissions shall be tabulated by the City who with the applicable sales tax rate whether that tax shall be charged through the supplier or paid by the City as use tax.	I agree and I acknowledge



#2	Bidder acknowledges it would apply applicable Sale, which currently is 9%, when invoicing.	I agree and I acknowledge
#3	Unit Pricing should Not Include Tax.	I agree and I acknowledge
#4	Bidder's prices shall be firm throughout the first year of the contract period.	Yes
#5	Unit Pricing shall be all-inclusive-cost-per-Transported-Ton.	I agree and I acknowledge
#5.1	All-inclusive-cost-per-Transported-Ton shall be all-inclusive of cost that could be incurred, to include but not limited to: Transport, Obtaining Weigh Tickets, Delivery, Unloading, Demurrage Charges, and any Fuel Surcharge.	I agree and I acknowledge
#5.2	Bidder acknowledges that ALL expenses that could be incurred were taken into account in Vendor's all-inclusive-cost-per-Transported-Ton stated on Pricing Form. No other costs will be allowed later.	I agree and I acknowledge
#6	Bidder has completed Pricing Form,	Yes
#7	PRICING ADJUSTMENTS:	Yes
#8.1	Adjustments to pricing shall be the result of increases at the manufacturer's level, incurred after contract commencement date, shall not produce a higher profit margin than that on the original contract, clearly identify the items impacted by the increase, and be accompanied by documentation acceptable to Spokane City sufficient to justify the requested increase. Spokane City will be the sole judge as to the acceptability of sources. Acceptance of a request will be at the sole discretion of Spokane City. Price increases will not be considered before the end of the first 12-months of the Contract. Approved price adjustments shall remain unchanged for at least 12 months thereafter unless due to extraordinary circumstances as documented by the Contractor and concurred with by the City. A written request for a price adjustment will be considered on anniversary date of contact award, should renewal be exercised. An approved price increase Retroactive price increase adjustments will not be considered.	I agree and I acknowledge
#8.2	Back up documentation from Vendor must be included to justify request.	I agree and I acknowledge

#8.3	All price adjustments must be agreed on by both parties. Vendor must request pricing adjustment in writing, and cannot be applied retroactively to transports already performed. Price increases must apply to all or broad classes of customers and shall in no way single out the Purchaser.	I agree and I acknowledge
#8.4	The City of Spokane reserves the right to cancel the contract if the escalation of price is not advantageous to the City. Failure to reach agreement on a request for an increase in price(s) can, at the sole option of the City, result in the termination of the Agreement for cause.	I agree and I acknowledge
#9	PRICE DECREASES. During the term of the contract, should the Vendor realize any or cost reductions, or enter into pricing agreements with other customers providing greater benefits or lower pricing, The Vendor shall immediately request that an amendment to the Contract to provide similar pricing to the City, if the contract with other customers offers similar usage quantities, and similar conditions impacting pricing. The Vendor shall immediately notify the City of any such contracts entered into by the Vendor. Price decreases may be considered and implemented at any time upon mutual consent of the parties.	I agree and I acknowledge
ADDITIONAL DOCUMENTS BIDDER WOULD LIKE TO UPLOAD		
#1	If you have additional information/documents to submit, upload them here.	
#2	If you have additional information/documents to submit, upload them here.	
#3	If you have additional information/documents to submit, upload them here.	
#4	If you have additional information/documents to submit, upload them here.	

**Pricing Responses**

Group	Reference Number	Description	Type	Unit Of Measure	Quantity	Unit Price	Ext Base Price	Comment

<p>Annual Quantities shown on "Pricing Tab" are estimates only and are not to be construed as firm or guaranteed. Quantities are estimates only and are given for the purpose of comparing bids on a uniform basis. Unit Pricing SHOULD NOT include tax.</p>							
#1	<p>All-inclusive Unit Price per Transported-Ton shall be firm throughout the first year of the contract period. Annual estimated quantity is 3,640 Tons. Unit price should not include tax.</p>	Base	Transported Cost Per Ton	3,640.00	\$16.00	\$58,240.00	<p>Bid does not account for any dump fees at Northside Landfill, dump fees to be paid by the City.</p>
<b>Total Base Bid</b>		\$58,240.00					



**Agenda Sheet for City Council:**

**Committee:** PIES **Date:** 10/21/2024

**Committee Agenda type:** Consent

**Date Rec'd** 10/22/2024

**Clerk's File #** OPR 2024-0929

**Cross Ref #**

**Project #**

**Council Meeting Date:** 11/04/2024

<b>Submitting Dept</b>	SOLID WASTE DISPOSAL	<b>Bid #</b>	ITB 6163-24
------------------------	----------------------	--------------	-------------

<b>Contact Name/Phone</b>	DAVID PAINE 625-6878	<b>Requisition #</b>	CR 26790
---------------------------	----------------------	----------------------	----------

<b>Contact E-Mail</b>	DPAINE@SPOKANECITY.ORG		
-----------------------	------------------------	--	--

<b>Agenda Item Type</b>	Contract Item		
-------------------------	---------------	--	--

<b>Council Sponsor(s)</b>	BWILKERSON JBINGLE KKLITZKE		
---------------------------	-----------------------------	--	--

<b>Agenda Item Name</b>	4490-CONTRACT AWARD FOR ON-SITE VALVE REPAIRS		
-------------------------	---	--	--

**Agenda Wording**

Contract award to Industrial Service Solutions aka Bay Valve Service, LLC (Longview, WA) for on-site valve repair services at the Waste to Energy Facility from 1/1/2025-12/31/2025 and a total cost not to exceed \$150,000.00 plus tax.

**Summary (Background)**

The Waste to Energy Facility has many valves that are critical to its operations. On-site maintenance is required for safe and efficient operation. A valve failure could result in a plant shutdown. On Sep. 30, 2024 bidding closed to ITB 6163-24 for these valve repair services and Industrial Service Solutions, LLC, aka Bay Valve Service, LLC was the only respondent. The initial contract award will be for one year with the possibility of four (4) additional one-year renewals.

Lease? NO Grant related? NO Public Works? YES

**Fiscal Impact**

Approved in Current Year Budget? YES

Total Cost	\$ 150,000.00
------------	---------------

Current Year Cost	\$ 0
-------------------	------

Subsequent Year(s) Cost	\$ 0
-------------------------	------

**Narrative**

This is a routine repair and maintenance expense that was planned for in the Solid Waste Disposal budget. All funds are not typically utilized on this type of contract but need to be in place to avoid emergency spending in the event of equipment failures.

**Amount**

**Budget Account**

Expense	\$ 150,000.00	# 4490-44100-37148-54803-34002
Select	\$	#
Select	\$	#
Select	\$	#
	\$	#
	\$	#



**Continuation of Wording, Summary, Approvals, and Distribution**

**Agenda Wording**

**Summary (Background)**

**Approvals**

<b><u>Dept Head</u></b>	AVERYT, CHRIS
<b><u>Division Director</u></b>	FEIST, MARLENE
<b><u>Accounting Manager</u></b>	ALBIN-MOORE, ANGELA
<b><u>Legal</u></b>	SCHOEDEL, ELIZABETH
<b><u>For the Mayor</u></b>	PICCOLO, MIKE

**Additional Approvals**

<b><u>PURCHASING</u></b>	PRINCE, THEA

**Distribution List**

Mike Dombek, mdombek@iss-na.com	mdorgan@spokanecity.org
jsalstrom@spokanecity.org	tprince@spokanecity.org
rrinderle@spokanecity.org	

## Committee Agenda Sheet

### Public Infrastructure, Environment & Sustainability Committee

<b>Committee Date</b>	October 21, 2024
<b>Submitting Department</b>	Solid Waste Disposal
<b>Contact Name</b>	David Paine
<b>Contact Email &amp; Phone</b>	<a href="mailto:dpaine@spokanecity.org">dpaine@spokanecity.org</a> , 509-625-6878
<b>Council Sponsor(s)</b>	Wilkerson, Bingle, Klitzke
<b>Select Agenda Item Type</b>	<input checked="" type="checkbox"/> Consent <input type="checkbox"/> Discussion    Time Requested:
<b>Agenda Item Name</b>	Contract award for on-site valve repairs at the Waste to Energy Facility
<b>Proposed Council Action</b>	<input checked="" type="checkbox"/> Approval to proceed to Legislative Agenda <input type="checkbox"/> Information Only
<b>Summary (Background)</b>	<p>The Waste to Energy Facility has many types of valves which are critical to the operation of the plant. On-site maintenance is required for safe and efficient operation. Any number of valve failures could result in a plant shutdown.</p> <p>On September 30, 2024 bidding closed to ITB 6163-24 for these valve repair services and Industrial Service Solutions, LLC, dba Bay Valve Service, LLC (Longview, WA) was the only response received. The initial contract award would be from Jan. 1, 2025 through Dec. 31, 2025 with the option of four (4) additional one-year renewals and an annual cost not to exceed \$150,000.00 plus tax.</p>
<b>Summary (Background)</b>	<p>*use the Fiscal Impact box below for relevant financial information</p>
<p><b>Fiscal Impact</b></p> <p><b>Approved in current year budget?</b>    <input checked="" type="checkbox"/> Yes    <input type="checkbox"/> No    <input type="checkbox"/> N/A</p> <p>Total Cost: <u>\$150,000.00</u></p> <p>    Current year cost: \$150,000.00</p> <p>    Subsequent year(s) cost:</p> <p><b>Narrative:</b> <u>This is a routine repair and maintenance expense that was planned for in the Solid Waste Disposal budget.</u></p> <p><b>Funding Source</b>    <input type="checkbox"/> One-time    <input checked="" type="checkbox"/> Recurring    <input type="checkbox"/> N/A</p> <p>Specify funding source: Program revenue</p> <p>Is this funding source sustainable for future years, months, etc? Yes</p> <p><b>Expense Occurrence</b>    <input type="checkbox"/> One-time    <input checked="" type="checkbox"/> Recurring    <input type="checkbox"/> N/A</p> <p>Other budget impacts: (revenue generating, match requirements, etc.)</p>	
<p><b>Operations Impacts (If N/A, please give a brief description as to why)</b></p> <ul style="list-style-type: none"> <li>• What impacts would the proposal have on historically excluded communities? Public works services and projects are designed to serve all citizens and businesses. We strive to offer a consistent level of service to all, to distribute public investment throughout the community and to respond to gaps in services identified in various City plans.</li> <li>• How will data be collected, analyzed, and reported concerning the effect of the program/policy by racial, ethnic, gender identity, national origin, income level, disability, sexual orientation, or other existing disparities?</li> </ul>	

N/A

- How will data be collected regarding the effectiveness of this program, policy, or product to ensure it is the right solution?

Public Works follows the City's established procurement and public works bidding regulations and policies to bring items forward, and then uses contract management best practices to ensure desired outcomes and regulatory compliance.

- Describe how this proposal aligns with current City Policies, including the Comprehensive Plan, Sustainability Action Plan, Capital Improvement Program, Neighborhood Master Plans, Council Resolutions, and others?

This work is consistent with annual budget strategies to limit costs and approved projects in the 6-year CIP.

**Council Subcommittee Review**

- Please provide a summary of council subcommittee review. If not reviewed by a council subcommittee, please explain why not.

Not applicable



**City of Spokane**  
**PUBLIC WORKS AGREEMENT**  
Title: **ONSITE VALVE REPAIR SERVICES**

This Agreement is made and entered into by and between the **CITY OF SPOKANE** as (“City”), a Washington municipal corporation, and **INDUSTRIAL SERVICE SOLUTIONS, LLC.**, whose address is 213 Douglas St., Longview, Washington 98632, as (“Contractor”) individually hereafter referenced as a “Party”, and together as the “Parties”.

WHEREAS, the purpose of this Contract is to provide Onsite Valve Repair Services, scheduled and unscheduled at the Waste to Energy Facility; and

WHEREAS, the Contractor has been selected through PW ITB 6163-24 issued by the City.

NOW, THEREFORE, in consideration of the terms, conditions, covenants and performance of the Scope of Work contained herein, the City and Contractor mutually agree as follows:

**1. TERM OF AGREEMENT.**

The term of this Agreement begins on January 1, 2025, and ends on December 31, 2025, unless amended by written agreement or terminated earlier under the provisions. The contract may be renewed for four (4) additional one-year (1) contract period, subject to mutual agreement.

**2. TIME OF BEGINNING AND COMPLETION.**

The Contractor shall begin the work outlined in the “Scope of Work” (“Work”) on the beginning date, above. The City will acknowledge in writing when the Work is complete. Time limits established under this Agreement shall not be extended because of delays for which the Contractor is responsible, but may be extended by the City, in writing, for the City’s convenience or conditions beyond the Contractor’s control.

**3. SCOPE OF WORK.**

The Contractor shall provide Onsite Valve Repair Services, scheduled and unscheduled, in accordance with their response to ITB 6163-24 attached as Exhibit C.

The Work is subject to City review and approval. The Contractor shall confer with the City periodically, and prepare and present information and materials (e.g. detailed outline of completed Work) requested by the City to determine the adequacy of the Work or Contractor’s progress.

**4. COMPENSATION / PAYMENT.**

Total compensation for Contractor’s services under this Agreement shall be a maximum amount not to exceed **ONE HUNDRED FIFTY THOUSAND AND NO/100 DOLLARS (\$150,000.00)**, plus applicable sales tax, in accordance with Response to Request to ITB, attached as Exhibit C. This



is the maximum amount to be paid under this Agreement for the work described in Section 3 above, and shall not be exceeded without the prior written authorization of the City in the form of an executed amendment to this Agreement.

The Contractor will send its applications for payment to the Spokane Solid Waste Disposal, 4900 South Geiger Blvd., Spokane, Washington 99224. All invoices should include the City Clerk's File No. "OPR 2024-XXXX" and an approved L & I Intent to Pay Prevailing Wage number. The final invoice should include an approved Affidavit of Wages Paid number. Payment will not be made without this documentation included on the invoice.

## **5. TAXES, FEES AND LICENSES.**

- A. Contractor shall pay and maintain in current status, all necessary licenses, fees, assessments, permit charges, etc. necessary to conduct the work included under this Agreement. It is the Contractor's sole responsibility to monitor and determine changes or the enactment of any subsequent requirements for said fees, assessments, or changes and to immediately comply.
- B. The cost of any permits, licenses, fees, etc. arising as a result of the projects included in this Agreement shall be included in the project budgets.

## **6. PREVAILING WAGES.**

The following public works requirements apply to the work under this Agreement.

- A. The State prevailing rate of wages to be paid to all workmen, laborers or mechanics employed in the performance of any part of this Contract shall be in accordance with the provisions of Chapter 39.12 of the Revised Code of Washington (RCW) and the rules and regulations of the Washington State Department of Labor and Industries. (L&I).
- B. State of Washington prevailing wage rates applicable for this public works project, which is located in Spokane County, may be found at the following website address of the Department of Labor and Industries:

<https://fortress.wa.gov/lni/wagelookup/prvWagelookup.aspx>

Prevailing wages for all work performed pursuant to each work order must be the prevailing wage rates in effect at the beginning date for each contract year. On call contracts must have prevailing wage rates updated annually. Intents and affidavits for prevailing wages paid must be submitted annually for all work completed within the previous twelve-month period of the unit priced contract. (RCW 35.22.620)

Upon the anniversary date of the contract, labor rates may be adjusted according to the revised prevailing wages adopted by the Department of Labor and Industries at that time. In order to calculate the change in prevailing wages due to the Contractor, the Contractor shall provide to the City of Spokane a breakdown of the fully loaded labor rates for each classification of labor including hourly wage rates, fringe benefits, overhead and profit. The City of Spokane shall not pay for any price escalation for overhead, profit, equipment, material, or any other costs except for changes in the prevailing wages. The revised prevailing wages shall be effective for any Work issued after the anniversary date of the contract. The basis of modified prevailing wage rates applicable for the contract shall be calculated

and issued in writing by the City of Spokane, but such changes shall not be included in a change order. To the extent that the contract sum changes, a change order will be issued as appropriate.

C. A payment/performance bond is NOT required.

D. Statutory retainage is NOT required.

#### **7. CITY OF SPOKANE BUSINESS LICENSE.**

Section 8.01.070 of the Spokane Municipal Code states that no person may engage in business with the City without first having obtained a valid annual business registration. The Contractor shall be responsible for contacting the State of Washington Business License Services at [www.dor.wa.gov](http://www.dor.wa.gov) or 360-705-6741 to obtain a business registration. If the Contractor does not believe it is required to obtain a business registration, it may contact the City's Taxes and Licenses Division at (509) 625-6070 to request an exemption status determination.

#### **8. SOCIAL EQUITY REQUIREMENTS / NON-DISCRIMINATION.**

No individual shall be excluded from participation in, denied the benefit of, subjected to discrimination under, or denied employment in the administration of or in connection with this Agreement because of age, sex, race, color, religion, creed, marital status, familial status, sexual orientation including gender expression or gender identity, national origin, honorably discharged veteran or military status, the presence of any sensory, mental or physical disability, or use of a service animal by a person with disabilities. The Contractor agrees to comply with, and to require that all subcontractors comply with, federal, state and local nondiscrimination laws, including but not limited to: the Civil Rights Act of 1964, the Rehabilitation Act of 1973, the Age Discrimination in Employment Act, and the American's With Disabilities Act, to the extent those laws are applicable.

#### **9. INDEMNIFICATION.**

The Contractor shall defend, indemnify, and hold the City and its officers and employees harmless from all claims, demands, or suits at law or equity-asserted by third parties for bodily injury (including death) and/or property damage which arise from the Contractor's negligence or willful misconduct under this Agreement, including attorneys' fees and litigation costs; provided that nothing herein shall require a Contractor to indemnify the City against and hold harmless the City from claims, demands or suits based solely upon the negligence of the City, its agents, officers, and employees. If a claim or suit is caused by or results from the concurrent negligence of the Consultant's/Contractor's/Company's agents or employees and the City, its agents, officers and employees, this indemnity provision shall be valid and enforceable to the extent of the negligence of the Contractor, its agents or employees. The Contractor specifically assumes liability and agrees to defend, indemnify, and hold the City harmless for actions brought by the Contractor's own employees against the City and, solely for the purpose of this indemnification and defense, the Contractor specifically waives any immunity under the Washington State industrial insurance law, or Title 51 RCW. The Contractor recognizes that this waiver was specifically entered into pursuant to the provisions of RCW 4.24.115 and was the subject of mutual negotiation. The indemnity and agreement to defend and hold the City harmless provided for in this section shall survive any termination or expiration of this agreement.

#### **10. INSURANCE.**

During the period of the Agreement, the Contractor shall maintain in force at its own expense, each insurance noted below with companies or through sources approved by the State Insurance Commissioner pursuant to Title 48 RCW:

A. **Worker's Compensation Insurance** in compliance with RCW 51.12.020, which requires subject employers to provide workers' compensation coverage for all their subject workers and Employer's Liability Insurance in the amount of \$1,000,000;

B. **General Liability Insurance** on an occurrence basis, with a combined single limit of not less than \$1,000,000 each occurrence for bodily injury and property damage. It shall include contractual liability coverage for the indemnity provided under this agreement. It shall provide that the City, its officers and employees are additional insureds but only with respect to the Contractor's services to be provided under this Agreement;

- i. Acceptable supplementary Umbrella coverage in combination with Commercial General Liability policy shall be a minimum of \$2M in order to meet the minimum insurance coverages required under this contract;

C. **Automobile Liability Insurance** with a combined single limit, or the equivalent of not less than \$1,000,000 each accident for bodily injury and property damage, including coverage for owned, hired and non-owned vehicles; and

D. **Property Insurance** if materials and supplies are furnished by the Contractor. The amount of the insurance coverage shall be the value of the materials and supplies of the completed value of improvement. Hazard or XCU (explosion, collapse, underground) insurance should be provided if any hazard exists.

There shall be no cancellation, material change, or intent not to renew the insurance coverage(s) without thirty (30) days written notice from the Contractor or its insurer(s) or insurers authorized representative to the City. As evidence of the insurance coverages required by this Agreement, the Contractor shall furnish ACORD form insurance certificates to the City at the time it returns the signed Agreement. The certificate shall specify all of the parties who are additional insureds to the extent of Company's indemnify obligations, and include applicable blanket-form policy endorsements, including the blanket-form notice of cancellation endorsements (30 days). The Contractor shall be financially responsible for all pertinent deductibles, self-insured retentions, and/or self-insurance.

## **11. SUBCONTRACTOR RESPONSIBILITY.**

The Contractor must verify responsibility criteria for each first tier subcontractor, and a subcontractor of any tier that hires other subcontractors must verify responsibility criteria for each of its subcontractors. Verification shall include that each subcontractor, at the time of subcontract execution, meets the responsibility criteria listed in RCW 39.04.350(1) and possesses an electrical contractor license, if required by chapter 19.28 RCW, or an elevator contractor license, if required by chapter 70.87 RCW.

## **12. INDEPENDENT CONTRACTOR.**

The Contractor is an independent Contractor. This Agreement does not intend the Contractor to act as a City employee. The City has neither direct nor immediate control over the Contractor nor the right to control the manner or means by which the Contractor works. Neither the Contractor nor any Contractor employee shall be an employee of the City. This Agreement prohibits the Contractor to act as an agent or legal representative of the City. The Contractor is not granted express or implied rights or authority to assume or create any obligation or responsibility for or in the name of the City, or to bind the City. The City is not liable for or obligated to pay sick leave,

vacation pay, or any other benefit of employment, nor to pay social security or other tax that may arise from employment. The Contractor shall pay all income and other taxes as due.

**13. ASSIGNMENT AND SUBCONTRACTING.**

The Contractor shall not assign or subcontract its obligations under this Agreement without the City's written consent, which may be granted or withheld in the City's sole discretion. Any subcontract made by the Contractor shall incorporate by reference this Agreement, except as otherwise provided. The Contractor shall ensure that all subcontractors comply with the obligations and requirements of the subcontract. **If City approves Contractor's request to utilize a subcontractor/s for a portion of the work to be performed, such approval shall be conditioned upon Contractor obtaining a payment bond for each subcontractor's work in advance of such work being performed and in an amount determined by the City.** The City's consent to any assignment or subcontract does not release the Contractor from liability or any obligation within this Agreement, whether before or after City consent, assignment or subcontract.

**14. TERMINATION.**

Either party may terminate this Agreement, with or without cause, by ten (10) days written notice to the other party. In the event of such termination, the City shall pay the Contractor for all work previously authorized and performed prior to the termination date.

**15. STANDARD OF PERFORMANCE.**

The standard of performance applicable to Contractor's services will be the degree of skill and diligence normally employed by professional contractors in the region performing the same or similar Contracting services at the time the work under this Agreement are performed.

**16. ANTI KICK-BACK.**

No officer or employee of the City of Spokane, having the power or duty to perform an official act or action related to this Agreement shall have or acquire any interest in the Agreement, or have solicited, accepted or granted a present or future gift, favor, service or other thing of value from or to any person involved in this Agreement.

**17. CONSTRUAL.**

The Contractor acknowledges receipt of a copy of the Agreement documents and agrees to comply with them. The silence or omission in the Agreement documents concerning any detail required for the proper execution and completion of the work means that only the best general practice is to prevail and that only material and workmanship of the best quality are to be used. This Contract shall be construed neither in favor of nor against either party.

**18. DEBARMENT AND SUSPENSION.**

The Contractor has provided its certification that it is in compliance with and shall not contract with individuals or organizations which are debarred, suspended, or otherwise excluded from or ineligible from participation in Federal Assistance Programs under Executive Order 12549 and "Debarment and Suspension", codified at 29 CFR part 98.

**19. CONTRACTOR'S ACKNOWLEDGEMENT AND WARRANTY.**

The Contractor acknowledges that it has visited the site of the work, has examined it, and is qualified to perform the work required by this Agreement.

The Contractor guarantees and warranties all work, labor and materials under this Agreement for two (2) years following final acceptance. If any unsatisfactory condition or defect develops within that time, the Contractor will immediately place the work in a condition satisfactory to the City and

repair all damage caused by the condition or defect. The Contractor will repair or restore to the City's satisfaction, in accordance with the contract documents and at its expense, all property damaged by his performance under this Agreement. This warranty is in addition to any manufacturers' or other warranty in the Agreement documents.

**20. MISCELLANEOUS PROVISIONS.**

- A. **Amendments/Modifications:** The City may modify this Agreement and order changes in the work whenever necessary or advisable. The Contractor will accept modifications when ordered in writing by the City, and the Agreement time and compensation will be adjusted accordingly.
- B. The Contractor, at no expense to the City, shall comply with all laws of the United States and Washington, the Charter and ordinances of the City of Spokane; and rules, regulations, orders and directives of their administrative agencies and officers.
- C. This Agreement shall be construed and interpreted under the laws of Washington. The venue of any action brought shall be in a court of competent jurisdiction, located in Spokane County, Washington.
- D. **Captions:** The titles of sections or subsections are for convenience only and do not define or limit the contents.
- E. **Severability:** If any term or provision is determined by a court of competent jurisdiction to be invalid or unenforceable, the remainder of this Agreement shall not be affected, and each term and provision shall be valid and enforceable to the fullest extent permitted by law.
- F. **Waiver:** No covenant, term or condition or the breach shall be deemed waived, except by written consent of the party against whom the waiver is claimed, and any waiver of the breach of any covenant, term or condition shall not be deemed a waiver of any preceding or succeeding breach of the same or any other covenant, term or condition. Neither the acceptance by the City of any performance by the Contractor after the time the same shall have become due nor payment to the Contractor for any portion of the Work shall constitute a waiver by the City of the breach or default of any covenant, term or condition unless otherwise expressly agreed to by the City in writing.
- G. **Entire Agreement:** This document along with any exhibits and all attachments, and subsequently issued addenda, comprises the entire agreement between the City and the Contractor. If conflict occurs between Agreement documents and applicable laws, codes, ordinances or regulations, the most stringent or legally binding requirement shall govern and be considered a part of this Agreement to afford the City the maximum benefits.
- H. **No personal liability:** No officer, agent or authorized employee of the City shall be personally responsible for any liability arising under this Agreement, whether expressed or implied, nor for any statement or representation made or in any connection with this Agreement.
- I. Under Washington State Law (reference RCW Chapter 42.56, the *Public Records Act* [PRA]) all materials received or created by the City of Spokane are **public records** and are available to the public for viewing via the City Clerk's Records (online) or a valid Public Records Request (PRR).

IN WITNESS WHEREOF, in consideration of the terms, conditions and covenants contained, or attached and incorporated and made a part, the parties have executed this Agreement by having legally-binding representatives affix their signatures below.

**INDUSTRIAL SERVICE SOLUTIONS, LLC.**

**CITY OF SPOKANE**

By \_\_\_\_\_  
Signature Date

By \_\_\_\_\_  
Signature Date

\_\_\_\_\_  
Type or Print Name

\_\_\_\_\_  
Type or Print Name

\_\_\_\_\_  
Title

\_\_\_\_\_  
Title

Attest:

Approved as to form:

\_\_\_\_\_  
City Clerk

\_\_\_\_\_  
Assistant City Attorney

**Attachments that are part of this Agreement:**

- Exhibit A – Debarment Certification
- Exhibit B - Certification of Compliance with Wage Payment Statutes
- Exhibit C – Contractor’s ITB 6163-24 Bid Response Summary

**EXHIBIT A**

**CERTIFICATION REGARDING DEBARMENT, SUSPENSION,  
INELIGIBILITY AND VOLUNTARY EXCLUSION**

1. The undersigned (i.e., signatory for the Subrecipient / Contractor / Consultant) certifies, to the best of its knowledge and belief, that it and its principals:
  - a. Are not presently debarred, suspended, proposed for debarment, declared ineligible, or voluntarily excluded from covered transactions by any federal department or agency;
  - b. Have not within a three-year period preceding this contract been convicted or had a civil judgment rendered against them for commission of fraud or a criminal offense in connection with obtaining, attempting to obtain, or performing a public (federal, state, or local) transaction or contract under a public transaction; violation of federal or state antitrust statutes or commission of embezzlement, theft, forgery, bribery, falsification or destruction of records, making false statements, tax evasion, receiving stolen property, making false claims, or obstruction of justice;
  - c. Are not presently indicted or otherwise criminally or civilly charged by a government entity (federal, state, or local) with commission of any of the offenses enumerated in paragraph (1)(b) of this certification; and,
  - d. Have not within a three-year period preceding this contract had one or more public transactions (federal, state, or local) terminated for cause or default.
2. The undersigned agrees by signing this contract that it shall not knowingly enter into any lower tier covered transaction with a person who is debarred, suspended, declared ineligible, or voluntarily excluded from participation in this covered transaction.
3. The undersigned further agrees by signing this contract that it will include the following clause, without modification, in all lower tier covered transactions and in all solicitations for lower tier covered transactions:

Certification Regarding Debarment, Suspension, Ineligibility and Voluntary Exclusion – Lower Tier Covered Transactions

1. The lower tier contractor certified, by signing this contract that neither it nor its principals is presently debarred, suspended, proposed for debarment, declared ineligible, or voluntarily excluded from participation in this transaction by any federal department or agency.
  2. Where the lower tier contractor is unable to certify to any of the statements in this contract, such contractor shall attach an explanation to this contract.
4. I understand that a false statement of this certification may be grounds for termination of the contract.

<hr/> <p>Name of Subrecipient / Contractor / Consultant (Type or Print)</p>	<hr/> <p>Program Title (Type or Print)</p>
<hr/> <p>Name of Certifying Official (Type or Print)</p>	<hr/> <p>Signature</p>
<hr/> <p>Title of Certifying Official (Type or Print)</p>	<hr/> <p>Date (Type or Print)</p>



# Certification of Compliance with Wage Payment Statutes and Washington Department of Labor and Industries Training Requirement

The bidder hereby certifies that, within the three-year period immediately preceding the bid solicitation date (\_\_\_\_\_), the bidder is not a “willful” violator, as defined in RCW 49.48.082, of any provision of chapters 49.46, 49.48, or 49.52 RCW, as determined by a final and binding citation and notice of assessment issued by the Department of Labor and Industries or through a civil judgment entered by a court of limited or general jurisdiction.

As of July 1, 2019, have fulfilled the Department of Labor and Industries’ Public Works and Prevailing Wage Training Requirement before bidding and/or performing work on public works projects under RCW 39.04.350 and RCW 39.06.020 by either of the following:

- 1) Received training on the requirements related to public works and prevailing wage under chapter RCW 39.04.350 and chapter 39.12; or
- 2) Be certified exempt by the Department of Labor and Industries by having completed three or more public work projects and have a had a valid business license in Washington for three or more years.

I certify under penalty of perjury under the laws of the State of Washington that the foregoing is true and correct.

\_\_\_\_\_  
Bidder’s Business Name

\_\_\_\_\_  
Signature of Authorized Official\*

\_\_\_\_\_  
Printed Name

\_\_\_\_\_  
Title

\_\_\_\_\_  
Date

\_\_\_\_\_  
City

\_\_\_\_\_  
State

**Check One:**

Sole Proprietorship  Partnership  Joint Venture  Corporation

State of Incorporation, or if not a corporation, State where business entity was formed:

\_\_\_\_\_  
If a co-partnership, give firm name under which business is transacted:

\_\_\_\_\_  
*\* If a corporation, proposal must be executed in the corporate name by the president or vice-president (or any other corporate officer accompanied by evidence of authority to sign). If a co-partnership, proposal must be executed by a partner.*



## EXHIBIT C

### Bid Response Summary

**Bid Number** ITB 6163-24  
**Bid Title** Onsite Valve Repair Services, Scheduled and Unscheduled - Prevailing Wages  
**Due Date** Monday, September 30, 2024 1:00:00 PM [(UTC-08:00) Pacific Time (US & Canada)]  
**Bid Status** Closed to Bidding  
**Company** Bay Valve Service, LLC  
**Submitted By** mdombek@bay-valve.com mdombek@bay-valve.com - Monday, September 30, 2024 8:07:47 AM [(UTC-08:00) Pacific Time (US & Canada)]  
 mdombek@bay-valve.com

**Comments**

**Question Responses**

Group	Reference Number	Question	Response
MANDTORY Pre-Bid			
	#1	PRE-BID CONFERENCE. A MANDATORY pre-bid conference will be held on Friday, September 20, 2024 at 10:00 am. The location will be at the Waste to Energy Facility (WTEF) Admin Offices, 2900 S Geiger Blvd., Spokane WA. This meeting is MANDATORY ONLY for those companies who have not previously performed Onsite Valve Repair Services at the City of Spokane Waste to Energy Facility.	YES
Contact Information			
	#1	List the following information for the person submitting this response: Company Name, Name, Address, Telephone Number & e-mail address	Industrial Service Solutions, LLC Mike Dombek 213 Douglas St Longview, WA 98632
	#2	Provide the name, phone number, and email address for the person in your Company that would potentially sign a contract through the DocuSign process used by the City.	Mike Dombek 360-578-0658 mike.dombek@iss-na.com 213 Douglas St Longview, WA 98632
CERTIFICATION OF COMPLIANCE WITH WAGE PAYMENT STATUS			
	#1	The Contractor hereby certifies that, within the three-year period immediately preceding the bid solicitation date for this Project, the contractor is not a "willful" violator, as defined in RCW 49.48.082, of any provision of chapters 49.46, 49.48, or 49.52 RCW, as determined by a final and binding citation and notice of assessment issued by the Department of Labor and Industries or through a civil judgment entered by a court of limited or general jurisdiction. I certify (or declare) under penalty of perjury under the laws of the State of Washington that the foregoing is true and correct.	YES
Technical Group			

#1	Please complete and upload Bid Proposal Pages 13 - 17 of the Onsite Valve Repair Services Document in the Documents tab	Bid Response ITB 6163 24.pdf
#2	The bid shall be accompanied by a copy of bid bond/bid security payable to the order of the City of Spokane, in an amount of not less than five percent (5%) of the total bid amount. Bid bonds must be by a surety company authorized to do business as a surety in Washington State. As soon as the bid prices have been compared, the City will release the bid security of all except the three (3) lowest responsible bidders. When the service agreement is signed and returned with proof of insurance, the other bid security will be released. If the bidder is awarded the contract and fails to enter into a contract and to provide proof of insurance within the required time period, the bid security shall be forfeited to the City of Spokane. (Blank form available under the 'Documents' tab). In addition to the bid deposit types included in this section, a bidder may have on file with the City Clerk an annual bid bond approved by the City Attorney.	ACKNOWLEDGED
#2.1	Please complete and upload Bid Bond - Page 18 of the Onsite Valve Repair Services Document in the Documents tab	2024 09 27 ISS LLC Bid Bond City of Spokane.pdf
#3	Please complete and upload Subcontractor List of the Onsite Valve Repair Services Document in the Documents tab	Subcontractor List.pdf
#4	How many Addenda do you acknowledge receipt of?	1
#5	Acknowledge that you have read and understand the following Liquidated Damages Paragraph: In the event the bidder is awarded the contract and fails to complete the work within the time limit or any agreed upon time extensions, liquidated damages shall be paid to the City of Spokane in the amount of TEN THOUSAND DOLLARS (\$10,000.00) per working day until the work is satisfactorily completed.	ACKNOWLEDGED
#6	Acknowledge that you have read and understand the following Contract Completion Time Paragraph. The bidder must adhere to the City's outage schedule.	ACKNOWLEDGED
#7	Supplemental Bidder Responsibility: Bidder must meet the mandatory bidder responsibility criteria called out in City of Spokane Supplemental Bidder Responsibility Criteria Form to be considered a responsible bidder.	ACKNOWLEDGED
#7.1	Bidders can complete the "Supplemental Bidder Responsibility Criteria Form With Work Experience Form" From The Bid Document ITB 6163-24, and upload here:	Supplemental Bidder Responsibility Criteria.pdf
#7.1.1	If not uploaded above, after bid opening and prior to award, the apparent low bidder, or contacted bidders, shall complete, sign and submit this form with attached documentation within twenty four (24) hours of notification.	ACKNOWLEDGED

Definitions		
#1	Mobilization shall include all activities and associated costs for transportation and set up contractor's personnel, equipment, tooling, and operating supplies to the site; establishment of offices, buildings, and other necessary general facilities for the contractor's operations at the site unless otherwise agreed upon by both parties.	YES
#2	Demobilization shall include all activities and costs for transportation and teardown of personnel, equipment, tooling, and supplies not required or included in the contract from the site; including the disassembly, removal, and site cleanup of offices, buildings, and other facilities assembled on the site specifically for this contract. If additional mobilization and or demobilization activities and costs are required during the performance of the contract as a result of an approved work change order, all costs related to the work change order must have been captured in the work change order and approved by the city in advance.	YES
Terms & Conditions		
#1	Bidder accepts the Terms & Conditions of this RFQ in accordance with the document so named in the 'Documents' tab. Should Vendor have selected "No" to acceptance of Terms and Conditions as set forth in PW ITB document so named in the 'Documents' tab, Proposer must submit requested exceptions document with its proposal. The City will consider and determine if exception will be accepted.	YES
#1.1	EXCEPTION: If you took exception to above, upload here	
#2	ELIGIBILITY FOR CITY CONTRACTS: Section 18.09.050 of the Spokane Municipal Code states that the recipient of a City contract, award or purchase order shall certify that it is not knowingly or intentionally a nuclear weapons producer. The Bidder certifies that his/her firm is not a nuclear weapons producer.	Certifies
ADDITIONAL INFORMATION		
#1	If you have additional information/documents to submit, upload them here.	91624 COI City of Spokane.pdf
#2	If you have additional information/documents to submit, upload them here.	
#3	If you have additional information/documents to submit, upload them here.	
#4	If you have additional information/documents to submit, upload them here.	



CITY OF SPOKANE - PURCHASING  
808 W. Spokane Falls Blvd.  
Spokane, Washington 99201-3316  
(509) 625-6400

## INVITATION TO BID

<p>ITB NUMBER: 6163-24 TITLE: Onsite Valve Repair Services; Scheduled and Unscheduled – Prevailing Wages</p> <p>BID COORDINATOR: Rick Rinderle, City of Spokane Purchasing Department</p> <p>MANDATORY PRE-BID CONFERENCE: FRIDAY, SEPTEMBER 20, 2024 at 10:00 am Waste to Energy Facility, Admin Offices, 2900 S Geiger Blvd, Spokane, WA 99224</p> <p>QUESTION DEADLINE: WEDNESDAY, September 25, 2024, at 10:00am pdt</p>	<p>PROPOSAL DUE DATE: Monday, September 30, 2024 TIME: 1:00 pm pdt</p> <p><u>Bid Submittal:</u> All Bids shall be submitted electronically through the ProcureWare online procurement system portal: <a href="https://spokane.procureware.com">https://spokane.procureware.com</a> before the due date and time.</p>
--	--

**BID SUBMITTED BY:**

**COMPANY** Industrial Service Solutions, LLC

**MAILING ADDRESS** 213 Douglas Street,

Longview, WA 98632

**PHYSICAL ADDRESS** 213 Douglas Street,

Longview, WA 98632

**PHONE NUMBER** 360-578-0658

**E-MAIL ADDRESS** mike.dombek@iss-na.com

*Rick Rinderle*

**Rick Rinderle  
Purchasing**

**These Next Seven Pages (Pages #13 – 17) Comprising Bid Proposal Must be COMPLETED ENTIRELY and Uploaded Into ProcureWare Via The Question Tab and corresponding question #1.**

**BID PROPOSAL**

**PROJECT:** ITB 6163-24  
Onsite Valve Repair Services; Scheduled and Unscheduled

**BIDDER'S DECLARATION.**

The undersigned bidder certifies that it has examined the site, read and understands the specifications for the above project, and agrees to comply with all applicable federal, state and local laws and regulations. The bidder is advised that by signature of this bid proposal it has acknowledged all bid requirements and signed all certificates contained herein. Bid prices should have incorporated all travel, lodging cost per <https://www.gsa.gov/travel/plan-book/gsa-lodging>, per diem per <https://www.gsa.gov/travel/plan-book/per-diem-rates>.

**BID OFFER.**

The price(s) listed in this bid proposal is tendered as an offer to furnish all labor, materials, equipment and supervision required to complete the proposed project in strict accordance with the contract documents. The bidder proposes to do the project at the following price:

January 1, 2025 through December 31, 2025:

**(Do Not Include Washington State Sales Tax In Unit Pricing)**

<b>BID ITEM 1: UNIT PRICE PER COLD IRON OUTAGE</b>				
Line #	Description	Estimated Hours, More Or Less, That Could Be Incurred for A Single Cold Iron Outage	Unit Price	Extended Total
1	Straight Time	344 hours, more or less	\$ 158.00 / HR	\$ 54,352.00
2	Overtime Labor	299 hours, more or less	\$238.00 / HR	\$ 71,162.00
3	Mob			\$25,000.00
4	Demob			\$25,000.00
	All travel, lodging cost per <a href="https://www.gsa.gov/travel/plan-book/gsa-lodging">https://www.gsa.gov/travel/plan-book/gsa-lodging</a> , per diem per <a href="https://www.gsa.gov/travel/plan-book/per-diem-rates">https://www.gsa.gov/travel/plan-book/per-diem-rates</a>			
5	Percentage Markup For Parts / Materials Above Cost			25 %
6	List Any Other Cost To Be Incurred: Machine Shop Trailer, EVT Testing Equipmet, Specialty Equipment, ECT..			\$ 12,500.00
7	Applicable Tax Rate			9%

<b>BID ITEM 2: UNIT PRICE PER NON-COLD IRON OUTAGE</b>				
Line #	Description	Estimated Hours, More Or Less, That Could Be Incurred for A Single Non-Cold Iron Outage	Unit Price	Extended Total
1	Straight Time	80 hours, more or less	\$158.00 / HR	\$ 12,640.00
2	Overtime Labor	40 hours, more or less	\$238.00 / HR	\$9,520.00
3	Mob			\$ 4,907.00
4	Demob			\$ 4,907.00
	All travel, lodging cost per <a href="https://www.gsa.gov/travel/plan-book/gsa-lodging">https://www.gsa.gov/travel/plan-book/gsa-lodging</a> , per diem per <a href="https://www.gsa.gov/travel/plan-book/per-diem-rates">https://www.gsa.gov/travel/plan-book/per-diem-rates</a>			
5	Percentage Markup For Parts / Materials Above Cost			25 %
6	List Any Other Cost To Be Incurred:  Machine Shop Trailer, EVT Testing Equipmet, ECT..			\$ 7,500.00
7	Applicable Tax Rate			9%

<b>BID ITEM 3: UNSCHEUDLED SERVICES EMERGENCY</b>				
EMERGENCY: Contractor To Be On-Site At WTE After Notification Within				12 Hrs
Line #	Description	Estimated Hours, More Or Less, That Could Be Incurred	Unit Price	Extended Total
1	Straight Time	16 hours, more or less	\$ 158.00 HR	\$ 2,528.00
2	Overtime Labor	8 hours, more or less	\$238.00 / HR	\$1,904.00
3	Mob			\$4,907.00
4	Demob			\$4,907.00
	All travel, lodging cost per <a href="https://www.gsa.gov/travel/plan-book/gsa-lodging">https://www.gsa.gov/travel/plan-book/gsa-lodging</a> , per diem per <a href="https://www.gsa.gov/travel/plan-book/per-diem-rates">https://www.gsa.gov/travel/plan-book/per-diem-rates</a>			
5	Percentage Markup For Parts / Materials Above Cost			25 %
6	List Any Other Cost To Be Incurred:			\$ 7,500.00
7	Applicable Tax Rate			9%

<b>BID ITEM 4: UNSCHEDULED SERVICES NON-EMERGENCY</b>				
Line #	Description	Estimated Yearly Quantity of Hours, More Or Less, That Could Be Incurred	Unit Price	Extended Total
1	Straight Time	16 hours, more or less	\$158.00 / HR	\$2,528.00
2	Overtime Labor	8 hours, more or less	\$238.00 / HR	\$1,904.00
3	Mob			\$4,907.00
4	Demob			\$4,907.00
	All travel, lodging cost per <a href="https://www.gsa.gov/travel/plan-book/gsa-lodging">https://www.gsa.gov/travel/plan-book/gsa-lodging</a> , per diem per <a href="https://www.gsa.gov/travel/plan-book/per-diem-rates">https://www.gsa.gov/travel/plan-book/per-diem-rates</a>			
5	Percentage Markup For Parts / Materials Above Cost			25 %
6	List Any Other Cost To Be Incurred:  Machine Shop Trailer, EVT Testing Equipment, Specialty Equipment, ECT..			\$ 7,500.00
7	Applicable Tax Rate			9%

**ADDENDA.**

The undersigned acknowledges receipt of addenda number(s) Addendum 1 and agrees that their requirements have been included in this bid proposal.

**CONTRACT COMPLETION TIME.**

The bidder must adhere to the City's outage schedule.

**PERIOD OF PERFORMANCE:** The bidder agrees the period of performance of any contract resulting from this ITB is tentatively scheduled to begin on or about January 1, 2025, and to end on December 31, 2025.

Contract renewals or extensions shall be initiated at the discretion of the City and subject to mutual agreement. The contract may be extended for Four (4) one-year periods with the total contract period not to exceed five years.

**LIQUIDATED DAMAGES.** If the Work is not completed within the stated completion time, the Contractor agrees to pay to the City liquidated damages in the amount of \$10,000 for each and every calendar day the work remains uncompleted. Which is a reasonable forecast of the damages likely to occur if Work is unfinished by the completion date.

**CONTRACTOR RESPONSIBILITY.**

Washington State Contractor's Registration No. INDUSSS791JM  
(must be in effect at time of bid submittal)

U.B.I. Number 603199008

Washington Employment Security Department Number 235,951-01

Washington Excise Tax Registration Number 603-199-0002



**IF PARTNERSHIP**

I certify that I know or have satisfactory evidence that the above named person signed this bid proposal, on oath stated that he/she was authorized to sign it and acknowledged it as the partner(s) of the bidder, a partnership, to be the free and voluntary act of such party for the uses and purposes herein mentioned.

Signed and Sworn To (or Affirmed) Before Me On \_\_\_\_\_  
date

(Seal Or Stamp)

\_\_\_\_\_  
Signature of Notary Public

My appointment expires \_\_\_\_\_

**IF CORPORATION**

I certify that I know or have satisfactory evidence that the above named person signed this bid proposal, on oath stated that he/she was authorized to sign it and acknowledged it as the representative of the bidder, a corporation, to be the free and voluntary act of such party for the uses and purposes herein mentioned.

Signed and Sworn To (or Affirmed) Before Me On 09/27/2024  
date

(Seal Or Stamp)

  
\_\_\_\_\_  
Signature of Notary Public

Amy E Martin  
Notary  
Public  
exp 05/01/2025



City of Spokane Business License Number 603199008-001-0002  
(The successful bidder and all subcontractors shall be licensed or have applied for a license to do business in the City of Spokane prior to proceeding with the proposed project.)

As of July 1, 2019, Contractor has fulfilled training requirement or is exempt from L & I's Public Works Training Requirement under RCW 39.04.350 and RCW 39.06.020.  
( X YES ) ( \_\_\_\_\_ NO )

**BID SECURITY.**

A bid security in the amount of FIVE PERCENT (5%) of the total project bid as indicated above, is attached to this bid proposal. If the bidder is awarded the contract and fails to enter into a construction contract and/or furnish payment / performance bond(s) and proof of insurance within the required time period, the bid security shall be forfeited to the City of Spokane.

**NON-COLLUSION.**

The undersigned authorized representative of the undersigned firm, being first sworn on oath, certifies that the firm has not, directly or indirectly, entered into any agreement, participated in any collusion, or otherwise taken any action in restraint of free competitive bidding in connection with the project for which this bid proposal is submitted.

Name of Bidder: INDUSTRIAL SERVICE SOLUTIONS, LLC

  
*Signature of Bidder's Authorized Representative*

BRANCH MANAGER  
*Title*

213 DOUGLAS STREET, LONGVIEW, WA 98632  
*Address*

360-578-0658  
*Phone*

**IF INDIVIDUAL**

Signed and Sworn To (or Affirmed) Before Me On \_\_\_\_\_  
*date*

(Seal Or Stamp) \_\_\_\_\_  
*Signature of Notary Public*

My appointment expires \_\_\_\_\_

**Next Six Pages (plus) Need To Be Completed and Uploaded Into ProcureWare Via The Question Tab and corresponding question #7, else provide within 24 hours after notification.**

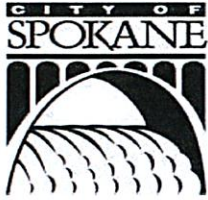

## City of Spokane, Washington Supplemental Bidder Responsibility Criteria

Should Bidders not have shall completed, sign and submit this form with attachments with Bid, then after bid opening and prior to award, the apparent low bidder, or those bidder contacted, shall complete, sign and submit this form with attachments to the City (See instructions at the end of this form). The form shall be submitted within twenty four (24) hours after the notification, unless a different time and date is required by the specifications or otherwise mutually agreed upon.	
Project Name Onsite Valve Repair Services; Scheduled and Unscheduled	
	Project # ITB 6163-24
<b>Part A: General Company Information</b>	
Company Name Industrial Service Solutions, LLC	
Address 213 Douglas Street, Longview, WA 98632	
Contact Name and Title Mike Dombek	Branch Manager
Contact Phone 360-578-0658	Contact E-mail mike.dombek@iss-na.com
Years in business as a Prime Contractor 40 +	Years in business as a sub-contractor 40 +
Years in business under present Name 10	
List any former company names under which the company, its owners, and/or its principals has operated in the past five (5) years	
Explain reason for name change(s) in the past five (5) years	
<b>Part B: Work Experience</b>	
If the request for bids has project specific criteria, including work experience, list at least the requested number of projects completed within the required time frame on the attached Project Experience form which are similar in type, size and scope of work required for this project	
<u>Multiple projects annually. power plants and paper mills.</u>	
<b>Part C: Performance Evaluation</b>	
Under past or present names does the bidder have a history of receiving "deficient" or "inadequate" evaluations on two (2) or more contracts from the City or other municipalities or another governmental agency on a public works project within the last five (5) years?	
<input type="checkbox"/> Yes <input checked="" type="checkbox"/> No	
If "Yes" attach a separate, signed / dated statement listing the projects and an explanation.	
<b>Part D: Record of Debarment / Disqualification</b>	

Has the bidder (including the primary contractor, any firm with which any of the primary contractor's owners, officers, or partners was associated) been debarred, disqualified, removed or has been otherwise prevented from bidding on, or completing any governmental agency or public works projects, including debarment by the federal, state or other municipal government during the last five (5) years?
<input type="checkbox"/> Yes <input checked="" type="checkbox"/> No
If "Yes", attach a separate signed / dated statement listing any debarments, disqualifications, removal, etc. from any governmental public works project and the basis for the action.
<b>Part E: Safety</b>
In the last five (5) years, has the bidder received willful or repeat violations of safety or health regulations by the OSHA or other agencies responsible for safety oversight? The Contractor shall submit safety records for the past three (3) years including OSHA 300A logs, recordable incidents, lost time accident statistics, EMR rating, OSHA type violations and NAICS code. The Contractor shall submit a list of any work activities previously performed at the City of Spokane WTEF. It is expected the contractor will have an EMR rating <1, OSHA recordable rate below industry average and no OSHA Violations for the past 3 years.
<input type="checkbox"/> Yes <input checked="" type="checkbox"/> No
If "Yes," attach a separate signed /dated statement describing each willful or repeat violation, including information about the dates and nature of the violations, the project on which the citation(s) was or were issued, the amount of penalty paid, if any. If the citation was appealed and a decision has been issued, state the case number and the date of the decision.
<b>Part F: Environmental</b>
In the last five (5) years, has the bidder received serious citations from government environmental enforcement agencies on projects for which the bidder was the contractor?
<input type="checkbox"/> Yes <input checked="" type="checkbox"/> No
If "Yes," attach a separate signed / dated statement describing each serious citation, including information about the dates of the citations, the nature of the violation, the project on which the citation(s) was or were issued, the amount of penalty paid, if any. If the citation was appealed and a decision has been issued, state the case number and the date of the decision.
<b>Part G: Discrimination</b>
Has the bidder or any of its owners, officers or partners been found guilty of violating or failing to comply with discrimination laws in contracting, employment or provision of public services?
<input type="checkbox"/> Yes <input checked="" type="checkbox"/> No
If "Yes", attach a separate signed / dated statement identifying the type of violation, who was involved, the name of the public agency, year of the investigation, the resolution in court or administrative process, and the grounds for the findings.
<b>Part H. Prevailing Wage</b>
In the last five (5) years, has the bidder received prevailing wage violations as determined by the applicable state or federal government agency monitoring prevailing and/or Davis Bacon wage compliance?
<input type="checkbox"/> Yes <input checked="" type="checkbox"/> No

<p>If "Yes," attach a separate signed/dated statement listing the prevailing wage violations, along with an explanation of each violation and how it was resolved. The City shall evaluate these explanations and the resolution of each violation to determine whether the violations demonstrate a pattern of failure to pay prevailing wages to workers unless there are extenuating circumstances acceptable to the City.</p>
<p><b>Part I. Claims Against Retainage and Bonds</b></p>
<p>Does the bidder have a record of multiple claims filed against the retainage or payment bonds for public works projects during the previous three (3) years?</p>
<p><input type="checkbox"/> Yes      <input checked="" type="checkbox"/> No</p>
<p>If "Yes", attach a separate signed / dated statement listing the claims filed against the retainage and/or payment bond for any completed public works projects and include for each project a written explanation of the circumstances surrounding the claim and the ultimate resolution of the claim. The City shall evaluate the statement to determine if it demonstrates a lack of effective management by the bidder of making timely and appropriate payments, unless there are extenuating circumstances acceptable to the City in its sole discretion.</p>
<p><b>Part J. Termination for Cause</b></p>
<p>Has the bidder had any public works contract terminated for cause by any government agency during the previous five (5) years?</p>
<p><input type="checkbox"/> Yes      <input checked="" type="checkbox"/> No</p>
<p>If "Yes", attach a separate signed / dated statement listing each contract terminated, the government agency terminating the contract and the circumstances involving the termination for cause. The City will determine if there are extenuating circumstances acceptable to the City in its sole discretion.</p>
<p><b>Part K: Litigation</b></p>
<p>Has the bidder been involved in lawsuits (or arbitrations for those instances where arbitration is completed in lieu of a lawsuit) with judgments entered against the bidder for failure to meet terms on contracts in the previous five (5) years?</p>
<p><input type="checkbox"/> Yes      <input checked="" type="checkbox"/> No</p>
<p>If "Yes", attach a list of lawsuits and/or arbitrations with judgments / arbitration awards entered against the bidder along with a written explanation of the circumstances surrounding each lawsuit and/or arbitration. The City will evaluate the explanations to determine whether the lawsuits and/or arbitrations demonstrate a pattern of failing to meeting terms of conditions of contracts, unless there are extenuating circumstances acceptable to the City in its sole discretion.</p>
<p><b>Part L: Delinquent State Taxes</b></p>
<p>Does the bidder owe delinquent taxes to the Washington State Department of Revenue without a payment plan approved by the Department before the date of contract award?</p>
<p><input type="checkbox"/> Yes      <input checked="" type="checkbox"/> No</p>
<p>If "Yes", attach a separate signed / dated statement describing the circumstances and stating that the bidder is not on the Washington State Department of Revenue's "Delinquent Taxpayer List".</p>
<p><b>Part M: Subcontractor Responsibility</b></p>
<p>Does the bidder's standard subcontract form include the subcontractor language required by RCW 39.06.020? Does the bidder have an established procedure which it uses to validate the responsibility of each of its subcontractor? Does the subcontract form require that each of the bidder's subcontractors have and document a similar procedure for sub-tier subcontractors?</p>

Yes     No

If "Yes" or "No", provide a copy of its standard subcontract form and a copy of the procedures used to validate the responsibility of subcontractors.

**Signature**

The undersigned certifies that the information and data contained herein is correct and complete. Failure to disclose information or submitting false or misleading information may result in rejection of my bid, revocation of award, contract termination, or may impact my firm's ability to bid on future projects by the City of Spokane.

Signature of Authorized Representative

Date



9/27/2024

Printed Name of Authorized Representative

Title

Mike Dombek

Branch Manager

BID BOND

We, Industrial Service Solutions, LLC, 940 Gessner Road, Suite 950, Houston, TX 77024 as Principal,  
and Berkley Insurance Company, 475 Steamboat Road, Greenwich, CT 06830 (203) 542-3800 as Surety, are held  
and firmly bound unto the CITY OF SPOKANE, a Washington State municipal corporation, in the penal  
sum of FIVE PERCENT (5%) OF THE TOTAL AMOUNT BID, for the payment of which we jointly and  
severally bind ourselves, and our legal representatives and successors THE CONDITIONS OF THE  
OBLIGATION are that if the City of Spokane shall make timely award to the Principal for the  
Onsite Valve Repair Services: Scheduled and Unscheduled  
according to the terms of the bid made by the Principal; and the Principal shall, within the specified time,  
enter into a contract with the City of Spokane and furnish bond(s) acceptable to the City, if required, then  
this obligation shall be null and void; otherwise it shall remain in full force and effect; but in no event will  
the surety's liability exceed this bond's face amount.

SIGNED AND SEALED on

September 30, 2024

AS PRINCIPAL

Industrial Service Solutions, LLC

By:

Kimmy Page

Title:

VP & General Counsel

A valid POWER OF  
ATTORNEY must accompany  
this bond.

Berkley Insurance Company

AS SURETY

Carol Quinn

By:

Lauren Blair

Lauren Blair Attorney in Fact



POWER OF ATTORNEY  
BERKLEY INSURANCE COMPANY  
WILMINGTON, DELAWARE

KNOW ALL MEN BY THESE PRESENTS, that BERKLEY INSURANCE COMPANY (the "Company"), a corporation duly organized and existing under the laws of the State of Delaware, having its principal office in Greenwich, CT, has made, constituted and appointed, and does by these presents make, constitute and appoint: *Anne M. Gliedt; Stephanie L. Klearman; DeAnna M. Maurer; Kevin McDaniel; Lauren Blair; Tamara Bowser; Roxanne Avila; Nancy Singleton; or Meredith McMillen of Lockton Companies, LLC of St. Louis, MO* its true and lawful Attorney-in-Fact, to sign its name as surety only as delineated below and to execute, seal, acknowledge and deliver any and all bonds and undertakings, with the exception of Financial Guaranty Insurance, providing that no single obligation shall exceed **Fifty Million and 00/100 U.S. Dollars (U.S.\$50,000,000.00)**, to the same extent as if such bonds had been duly executed and acknowledged by the regularly elected officers of the Company at its principal office in their own proper persons.

This Power of Attorney shall be construed and enforced in accordance with, and governed by, the laws of the State of Delaware, without giving effect to the principles of conflicts of laws thereof. This Power of Attorney is granted pursuant to the following resolutions which were duly and validly adopted at a meeting of the Board of Directors of the Company held on January 25, 2010:

**RESOLVED**, that, with respect to the Surety business written by Berkley Surety, the Chairman of the Board, Chief Executive Officer, President or any Vice President of the Company, in conjunction with the Secretary or any Assistant Secretary are hereby authorized to execute powers of attorney authorizing and qualifying the attorney-in-fact named therein to execute bonds, undertakings, recognizances, or other suretyship obligations on behalf of the Company, and to affix the corporate seal of the Company to powers of attorney executed pursuant hereto; and said officers may remove any such attorney-in-fact and revoke any power of attorney previously granted; and further

**RESOLVED**, that such power of attorney limits the acts of those named therein to the bonds, undertakings, recognizances, or other suretyship obligations specifically named therein, and they have no authority to bind the Company except in the manner and to the extent therein stated; and further

**RESOLVED**, that such power of attorney revokes all previous powers issued on behalf of the attorney-in-fact named; and further

**RESOLVED**, that the signature of any authorized officer and the seal of the Company may be affixed by facsimile to any power of attorney or certification thereof authorizing the execution and delivery of any bond, undertaking, recognizance, or other suretyship obligation of the Company; and such signature and seal when so used shall have the same force and effect as though manually affixed. The Company may continue to use for the purposes herein stated the facsimile signature of any person or persons who shall have been such officer or officers of the Company, notwithstanding the fact that they may have ceased to be such at the time when such instruments shall be issued.

IN WITNESS WHEREOF, the Company has caused these presents to be signed and attested by its appropriate officers and its corporate seal hereunto affixed this 2<sup>nd</sup> day of May, 2024.



Attest:  
By Philip S. Welt  
Philip S. Welt  
Executive Vice President & Secretary

Berkley Insurance Company  
By Jeffrey M. Hafter  
Jeffrey M. Hafter  
Senior Vice President

STATE OF CONNECTICUT )  
 ) ss:  
COUNTY OF FAIRFIELD )

Sworn to before me, a Notary Public in the State of Connecticut, this 2<sup>nd</sup> day of May, 2024, by Philip S. Welt and Jeffrey M. Hafter who are sworn to me to be the Executive Vice President and Secretary, and the Senior Vice President, respectively, of Berkley Insurance Company.

MARIA C. RINDBAKEN  
NOTARY PUBLIC  
CONNECTICUT

MY COMMISSION EXPIRES 04-30-2029

Maria C. Rindbaken  
Notary Public, State of Connecticut

CERTIFICATE

I, the undersigned, Assistant Secretary of BERKLEY INSURANCE COMPANY, DO HEREBY CERTIFY that the foregoing is a true, correct and complete copy of the original Power of Attorney; that said Power of Attorney has not been revoked or rescinded and that the authority of the Attorney-in-Fact set forth therein, who executed the bond or undertaking to which this Power of Attorney is attached, is in full force and effect as of this date.



Given under my hand and seal of the Company, this 30th day of September, 2024.

Vincent P. Forte  
Vincent P. Forte



THIS FORM MUST BE COMPLETED AND UPLOADED INTO THE CITY OF SPOKANE'S ELECTRONIC BIDDING SYSTEM OR INFORMATION MUST BE SUBMITTED ONLINE PER INSTRUCTIONS TO BIDDERS (Response Tab, Section Bid, Paragraph #3)

# SUBCONTRACTOR LIST

## City of Spokane Project Name: ITB 6163-24, Onsite Valve Repair Services; Scheduled and Unscheduled

This form is to be submitted with the Bid Proposal, or within one (1) hour after the published bid submittal time, unless bidder had submitted it with its bid response.

### **RCW 39.30.060** (as amended) states:

“Every invitation to bid on a prime contract that is expected to cost one million dollars or more for the construction, alteration, or repair of any public building or public work ... shall require each prime contract bidder to submit as part of the bid, or within one (1) hour after the published bid submittal time, the names of the subcontractors with whom the bidder, if awarded the contract, will subcontract for performance of the work of: electrical as described in chapter 19.28 RCW, or to name itself for the work.

**The prime contract bidder shall not list more than one (1) subcontractor for each category of work identified, unless subcontractors vary with bid alternates, in which case the prime contract bidder must indicate which subcontractor will be used for which alternate. Failure of the prime contract bidder to submit as part of the bid the names of such subcontractors or to name itself to perform such work or the naming of two or more subcontractors to perform the same work shall render the prime contract bidder's bid nonresponsive and, therefore, void.**” (emphasis added)

Subcontractor Named (List prime contract bidder if prime contract bidder intends to self-perform the work): \_\_\_\_\_

Work to be performed: N/A

Subcontractor Named: (List prime contract bidder if prime contract bidder intends to self-perform the work)) \_\_\_\_\_

Work to be performed: N/A

Subcontractor Named (List prime contract bidder if prime contract bidder intends to self-perform the work): \_\_\_\_\_

Work to be performed: N/A

Subcontractor Named (List prime contract bidder if prime contract bidder intends to self-perform the work): \_\_\_\_\_

Work to be performed: N/A

Subcontractor Named (List prime contract bidder if prime contract bidder intends to self-perform the work): \_\_\_\_\_

Work to be performed: N/A



# CERTIFICATE OF LIABILITY INSURANCE

7/1/2025

DATE (MM/DD/YYYY)

9/16/2024

THIS CERTIFICATE IS ISSUED AS A MATTER OF INFORMATION ONLY AND CONFERS NO RIGHTS UPON THE CERTIFICATE HOLDER. THIS CERTIFICATE DOES NOT AFFIRMATIVELY OR NEGATIVELY AMEND, EXTEND OR ALTER THE COVERAGE AFFORDED BY THE POLICIES BELOW. THIS CERTIFICATE OF INSURANCE DOES NOT CONSTITUTE A CONTRACT BETWEEN THE ISSUING INSURER(S), AUTHORIZED REPRESENTATIVE OR PRODUCER, AND THE CERTIFICATE HOLDER.

IMPORTANT: If the certificate holder is an ADDITIONAL INSURED, the policy(ies) must have ADDITIONAL INSURED provisions or be endorsed. If SUBROGATION IS WAIVED, subject to the terms and conditions of the policy, certain policies may require an endorsement. A statement on this certificate does not confer rights to the certificate holder in lieu of such endorsement(s).

<b>PRODUCER</b> LOCKTON COMPANIES, LLC 500 West Monroe, Suite 3400 CHICAGO IL 60661 (312) 669-6900 midwestcertificates@lockton.com		<b>CONTACT NAME:</b> <b>PHONE (A/C. No. Ext):</b> <span style="float:right"><b>FAX (A/C. No):</b></span> <b>E-MAIL ADDRESS:</b>																						
<b>INSURED</b> 1398515 Industrial Service Solutions LLC f/k/a Bay Valve Service & Engineering LLC Bay Valve Service, LLC 4385 S. 133rd Street Tukwila, WA 98168-3284		<table border="1"> <thead> <tr> <th colspan="2">INSURER(S) AFFORDING COVERAGE</th> <th>NAIC #</th> </tr> </thead> <tbody> <tr> <td><b>INSURER A :</b></td> <td>Starr Indemnity &amp; Liability Company</td> <td>38318</td> </tr> <tr> <td><b>INSURER B :</b></td> <td>Sentry Casualty Company</td> <td>28460</td> </tr> <tr> <td><b>INSURER C :</b></td> <td></td> <td></td> </tr> <tr> <td><b>INSURER D :</b></td> <td></td> <td></td> </tr> <tr> <td><b>INSURER E :</b></td> <td></td> <td></td> </tr> <tr> <td><b>INSURER F :</b></td> <td></td> <td></td> </tr> </tbody> </table>		INSURER(S) AFFORDING COVERAGE		NAIC #	<b>INSURER A :</b>	Starr Indemnity & Liability Company	38318	<b>INSURER B :</b>	Sentry Casualty Company	28460	<b>INSURER C :</b>			<b>INSURER D :</b>			<b>INSURER E :</b>			<b>INSURER F :</b>		
INSURER(S) AFFORDING COVERAGE		NAIC #																						
<b>INSURER A :</b>	Starr Indemnity & Liability Company	38318																						
<b>INSURER B :</b>	Sentry Casualty Company	28460																						
<b>INSURER C :</b>																								
<b>INSURER D :</b>																								
<b>INSURER E :</b>																								
<b>INSURER F :</b>																								

**COVERAGES**                      **CERTIFICATE NUMBER:** 20946546                      **REVISION NUMBER:** XXXXXXX

THIS IS TO CERTIFY THAT THE POLICIES OF INSURANCE LISTED BELOW HAVE BEEN ISSUED TO THE INSURED NAMED ABOVE FOR THE POLICY PERIOD INDICATED. NOTWITHSTANDING ANY REQUIREMENT, TERM OR CONDITION OF ANY CONTRACT OR OTHER DOCUMENT WITH RESPECT TO WHICH THIS CERTIFICATE MAY BE ISSUED OR MAY PERTAIN, THE INSURANCE AFFORDED BY THE POLICIES DESCRIBED HEREIN IS SUBJECT TO ALL THE TERMS, EXCLUSIONS AND CONDITIONS OF SUCH POLICIES. LIMITS SHOWN MAY HAVE BEEN REDUCED BY PAID CLAIMS.

INSR LTR	TYPE OF INSURANCE	ADDL INSD	SUBR WVD	POLICY NUMBER	POLICY EFF (MM/DD/YYYY)	POLICY EXP (MM/DD/YYYY)	LIMITS
A	<input checked="" type="checkbox"/> <b>COMMERCIAL GENERAL LIABILITY</b>  <input type="checkbox"/> CLAIMS-MADE <input checked="" type="checkbox"/> OCCUR  GEN'L AGGREGATE LIMIT APPLIES PER: <input type="checkbox"/> POLICY <input checked="" type="checkbox"/> PRO-JECT <input type="checkbox"/> LOC OTHER:	N	N	1000090558241	7/1/2024	7/1/2025	EACH OCCURRENCE \$ 1,000,000 DAMAGE TO RENTED PREMISES (Ea occurrence) \$ 300,000 MED EXP (Any one person) \$ 10,000 PERSONAL & ADV INJURY \$ 1,000,000 GENERAL AGGREGATE \$ 2,000,000 PRODUCTS - COMP/OP AGG \$ 2,000,000 \$
A	<input checked="" type="checkbox"/> <b>AUTOMOBILE LIABILITY</b> <input checked="" type="checkbox"/> ANY AUTO <input type="checkbox"/> OWNED AUTOS ONLY <input type="checkbox"/> SCHEDULED AUTOS <input type="checkbox"/> HIRED AUTOS ONLY <input type="checkbox"/> NON-OWNED AUTOS ONLY	N	N	1000635932241	7/1/2024	7/1/2025	COMBINED SINGLE LIMIT (Ea accident) \$ 5,000,000 BODILY INJURY (Per person) \$ XXXXXXXX BODILY INJURY (Per accident) \$ XXXXXXXX PROPERTY DAMAGE (Per accident) \$ XXXXXXXX \$ XXXXXXXX
A	<input type="checkbox"/> <b>UMBRELLA LIAB</b> <input checked="" type="checkbox"/> OCCUR <input checked="" type="checkbox"/> <b>EXCESS LIAB</b> <input type="checkbox"/> CLAIMS-MADE DED      RETENTION \$	N	N	1000095396241	7/1/2024	7/1/2025	EACH OCCURRENCE \$ 5,000,000 AGGREGATE \$ 5,000,000 \$ XXXXXXXX
B B	<b>WORKERS COMPENSATION AND EMPLOYERS' LIABILITY</b> ANY PROPRIETOR/PARTNER/EXECUTIVE OFFICER/MEMBER EXCLUDED? (Mandatory in NH) If yes, describe under DESCRIPTION OF OPERATIONS below	Y/N N	N/A	90-21694-003 (AOS) 90-21694-004 (WI)	7/1/2024 7/1/2024	7/1/2025 7/1/2025	<input checked="" type="checkbox"/> PER STATUTE <input type="checkbox"/> OTH-ER E.L. EACH ACCIDENT \$ 1,000,000 E.L. DISEASE - EA EMPLOYEE \$ 1,000,000 E.L. DISEASE - POLICY LIMIT \$ 1,000,000

DESCRIPTION OF OPERATIONS / LOCATIONS / VEHICLES (ACORD 101, Additional Remarks Schedule, may be attached if more space is required)

**CERTIFICATE HOLDER**

**CANCELLATION** See Attachment

<b>20946546</b> City of Spokane 808 W. Spokane Falls Blvd. Spokane WA 99201-3316	<p>SHOULD ANY OF THE ABOVE DESCRIBED POLICIES BE CANCELLED BEFORE THE EXPIRATION DATE THEREOF, NOTICE WILL BE DELIVERED IN ACCORDANCE WITH THE POLICY PROVISIONS.</p> <p>AUTHORIZED REPRESENTATIVE</p>
---	--

© 1988-2015 ACORD CORPORATION. All rights reserved.



City of Spokane

**To whom it may concern:**

In our continuing effort to provide timely certificate delivery, Lockton Companies is transitioning to paperless delivery of Certificates of Insurance.

To ensure electronic delivery for future renewals of this certificate, we need your email address. Please contact us via one of the methods below, referencing Certificate ID **20946546**.

- Email: [Chicagoedelivery@lockton.com](mailto:Chicagoedelivery@lockton.com)
- Phone: 866-297-8023

If you received this certificate through an internet link where the current certificate is viewable, we have your email and no further action is needed.

In the event your mailing address has changed, will change in the future, or you no longer require this certificate, please let us know using one of the methods above.

*The above inbox is for automating electronic delivery of certificates only. Please do NOT send future certificate requests to this inbox.*

Thank you for your cooperation and willingness in reducing our environmental footprint.

**Lockton Companies**

Lockton Companies  
500 W. Monroe Street, Suite 3400  
Chicago, IL 60661



< Business Lookup

### License Information:

[New search](#) [Back to results](#)

**Entity name:** INDUSTRIAL SERVICE SOLUTIONS, LLC

**Business name:** BAY VALVE SERVICE & ENGINEERING, LLC

**Entity type:** [Limited Liability Company](#)

**UBI #:** 603-199-008

**Business ID:** 001

**Location ID:** 0002

**Location:** Active

**Location address:** 213 DOUGLAS ST  
LONGVIEW WA 98632-1771

**Mailing address:** 4385 S 133RD ST  
TUKWILA WA 98168-3284

**Excise tax and reseller permit status:** [Click here](#)

**Secretary of State status:** [Click here](#)

### Endorsements

Endorsements held at this location	License #	Count	Details	Status	Expiration date	First issuance date
<a href="#">Kelso General Business - Non-Resident</a>	A040099			Active	Jan-31-2025	Apr-23-2015
<a href="#">Longview General Business</a>	824907			Active	Jan-31-2025	Feb-06-2018
<a href="#">Spokane General Business - Non-Resident</a>				Active	Jan-31-2025	Jan-22-2018

### Governing People May include governing people not registered with Secretary of State

Governing people	Title
PAGE, TAMMY	

### Registered Trade Names

Registered trade names	Status	First issued
BAY VALVE SERVICE	Active	Jul-24-2012
BAY VALVE SERVICE & ENGINEERING LLC	Active	Feb-13-2017
INDUSTRIAL SERVICE SOLUTIONS, LLC	Active	Mar-18-2024

[View Additional Locations](#)

The Business Lookup information is updated nightly. Search date and time: 10/2/2024 1:35:30 PM

[Contact us](#)

[How are we doing?](#)  
[Take our survey!](#)

[Don't see what you expected?](#)





< Business Lookup

### License Information:

[New search](#) [Back to results](#)

**Entity name:** INDUSTRIAL SERVICE SOLUTIONS, LLC

**Business name:** BAY VALVE SERVICE & ENGINEERING, LLC

**Entity type:** [Limited Liability Company](#)

**UBI #:** 603-199-008

**Business ID:** 001

**Location ID:** 0002

**Location:** Active

**Location address:** 213 DOUGLAS ST  
LONGVIEW WA 98632-1771

**Mailing address:** 4385 S 133RD ST  
TUKWILA WA 98168-3284

**Excise tax and reseller permit status:** [Click here](#)

**Secretary of State status:** [Click here](#)

### Endorsements

Endorsements held at this location	License #	Count	Details	Status	Expiration date	First issuance date
<a href="#">Kelso General Business - Non-Resident</a>	A040099			Active	Jan-31-2025	Apr-23-2015
<a href="#">Longview General Business</a>	824907			Active	Jan-31-2025	Feb-06-2018
<a href="#">Spokane General Business - Non-Resident</a>				Active	Jan-31-2025	Jan-22-2018

### Governing People May include governing people not registered with Secretary of State

Governing people	Title
PAGE, TAMMY	

### Registered Trade Names

Registered trade names	Status	First issued
BAY VALVE SERVICE	Active	Jul-24-2012
BAY VALVE SERVICE & ENGINEERING LLC	Active	Feb-13-2017
INDUSTRIAL SERVICE SOLUTIONS, LLC	Active	Mar-18-2024

[View Additional Locations](#)

The Business Lookup information is updated nightly. Search date and time: 10/2/2024 1:35:30 PM

[Contact us](#)

[How are we doing?](#)  
[Take our survey!](#)

[Don't see what you expected?](#)



**Agenda Sheet for City Council:****Committee:** PIES **Date:** 10/21/2024**Committee Agenda type:** Consent**Date Rec'd**

10/22/2024

**Clerk's File #**

OPR 2024-0930

**Cross Ref #****Project #****Council Meeting Date:** 11/04/2024**Submitting Dept**

SOLID WASTE DISPOSAL

**Bid #**

ITB 6184-24

**Contact Name/Phone**

DAVID PAINE 625-6878

**Requisition #****Contact E-Mail**

DPAINE@SPOKANECITY.ORG

**Agenda Item Type**

Contract Item

**Council Sponsor(s)**

BWILKERSON JBINGLE KKLITZKE

**Agenda Item Name**

4490-CONTRACT FOR CRANE/HOIST/TROLLEY/LIFELINE MAINTENANCE AND

**Agenda Wording**

Five year contract award to WEMCO, Inc. (Spokane, WA) for crane, hoist, trolley and lifeline preventative maintenance and inspections at the Waste to Energy Facility from 1/1/2025-12/31/2029 and a total cost not to exceed \$430,000.00 plus tax.

**Summary (Background)**

The Waste to Energy Facility utilizes a variety of cranes in many different areas. All of this equipment requires quarterly inspections and as-needed repairs and maintenance. On September 30, 2024, bidding closed on ITB 6184-24 for these services and WEMCO, Inc. was the only respondent. The resulting contract would be for five years with a total cost not to exceed \$430,000.00 plus tax.

Lease? NO Grant related? NO Public Works? YES

**Fiscal Impact**

Approved in Current Year Budget? YES

Total Cost \$ 430,000.00

Current Year Cost \$ 86,000.00

Subsequent Year(s) Cost \$ 86,000.00

**Narrative**

This is a routine repair and maintenance expense that was planned for in the Solid Waste Disposal budget. All funds are not typically utilized on this type of contract but need to be in place to avoid emergency spending in the event of equipment failures.

**Amount****Budget Account**

Expense \$ 430,000.00

# 4490-44100-37148-54803-34002

Select \$

#

Select \$

#

Select \$

#

\$

#

\$

#





**Continuation of Wording, Summary, Approvals, and Distribution**

**Agenda Wording**

**Summary (Background)**

**Approvals**

<b><u>Dept Head</u></b>	AVERYT, CHRIS
<b><u>Division Director</u></b>	FEIST, MARLENE
<b><u>Accounting Manager</u></b>	ALBIN-MOORE, ANGELA
<b><u>Legal</u></b>	HARRINGTON,
<b><u>For the Mayor</u></b>	PICCOLO, MIKE

**Additional Approvals**

<b><u>PURCHASING</u></b>	PRINCE, THEA

**Distribution List**

Matt Turner, mturner@wemcoinc.com	mdorgan@spokanecity.org
jsalstrom@spokanecity.org	tprince@spokanecity.org
rrinderle@spokanecity.org	mhumphrey@wemcoinc.com

## Committee Agenda Sheet

### Public Infrastructure, Environment & Sustainability Committee

<b>Committee Date</b>	October 21, 2024
<b>Submitting Department</b>	Solid Waste Disposal
<b>Contact Name</b>	David Paine
<b>Contact Email &amp; Phone</b>	<a href="mailto:dpaine@spokanecity.org">dpaine@spokanecity.org</a> , 509-625-6878
<b>Council Sponsor(s)</b>	Wilkerson, Bingle, Klitzke
<b>Select Agenda Item Type</b>	<input checked="" type="checkbox"/> Consent <input type="checkbox"/> Discussion    Time Requested:
<b>Agenda Item Name</b>	Contract for crane, hoist, trolley and lifeline maintenance and inspections at the Waste to Energy Facility.
<b>Proposed Council Action</b>	<input checked="" type="checkbox"/> Approval to proceed to Legislative Agenda <input type="checkbox"/> Information Only
<b>Summary (Background)</b>  *use the Fiscal Impact box below for relevant financial information	<p>The WTE Facility utilizes cranes in many different areas, including double girder top-riding cranes, in-house monorail cranes and two lifeline cranes in its operations. All of this equipment requires quarterly inspections and as-needed repairs by certified inspectors and technicians.</p> <p>On September 30, 2024 bidding closed on ITB 6184-24 for these services on all of the cranes excluding the two refuse-handling bridge cranes. WEMCO, Inc. of Spokane, WA was the only response received. The contract would be for five (5) years from January 1, 2025 through December 31, 2029 with a total cost not to exceed \$430,000.00 plus tax.</p>
<p><b>Fiscal Impact</b></p> <p><b>Approved in current year budget?</b>    <input checked="" type="checkbox"/> Yes    <input type="checkbox"/> No    <input type="checkbox"/> N/A</p> <p>Total Cost: <u>\$430,000.00 plus tax</u></p> <p>    Current year cost: \$86,000.00</p> <p>    Subsequent year(s) cost: \$86,000.00</p> <p><b>Narrative:</b> <u>This is a routine repair and maintenance expense that was planned for in the Solid Waste Disposal budget.</u></p> <p><b>Funding Source</b>            <input type="checkbox"/> One-time    <input checked="" type="checkbox"/> Recurring    <input type="checkbox"/> N/A</p> <p>Specify funding source: Program revenue</p> <p>Is this funding source sustainable for future years, months, etc? Yes</p> <p><b>Expense Occurrence</b>    <input type="checkbox"/> One-time    <input type="checkbox"/> Recurring    <input type="checkbox"/> N/A</p> <p>Other budget impacts: (revenue generating, match requirements, etc.)</p>	
<p><b>Operations Impacts</b> (If N/A, please give a brief description as to why)</p> <ul style="list-style-type: none"> <li>• What impacts would the proposal have on historically excluded communities? Public works services and projects are designed to serve all citizens and businesses. We strive to offer a consistent level of service to all, to distribute public investment throughout the community and to respond to gaps in services identified in various City plans.</li> <li>• How will data be collected, analyzed, and reported concerning the effect of the program/policy by racial, ethnic, gender identity, national origin, income level, disability, sexual orientation, or other existing disparities?</li> </ul>	

N/A

- How will data be collected regarding the effectiveness of this program, policy, or product to ensure it is the right solution?

Public Works follows the City's established procurement and public works bidding regulations and policies to bring items forward, and then uses contract management best practices to ensure desired outcomes and regulatory compliance.

- Describe how this proposal aligns with current City Policies, including the Comprehensive Plan, Sustainability Action Plan, Capital Improvement Program, Neighborhood Master Plans, Council Resolutions, and others?

This work is consistent with annual budget strategies to limit costs and approved projects in the 6-year CIP.

**Council Subcommittee Review**

- Please provide a summary of council subcommittee review. If not reviewed by a council subcommittee, please explain why not.

Not applicable



**City of Spokane**

**PREVENTATIVE MAINTENANCE AGREEMENT**

**Title: Quarterly Crane, Hoist, Trolley,  
and Lifeline Inspections and Services**

This Agreement is made and entered into by and between the **CITY OF SPOKANE** as ("City"), a Washington municipal corporation, and **WEMCO, INC.**, whose address is 5510 West Thorpe Road, Spokane, Washington 99224 as ("Contractor"), individually hereafter referenced as a "Party", and together as the "Parties".

*WHEREAS, the purpose of this Agreement is to provide Quarterly Crane, Hoist, Trolley and Lifeline Preventative Maintenance Inspections and Services; and*

*WHEREAS, the Contractor was selected from ITB 6184-24.*

*NOW, THEREFORE, in consideration of the terms, conditions, covenants and performance of the Scope of Work contained herein, the City and Contractor mutually agree as follows:*

**1. TERM OF AGREEMENT.**

The term of this Agreement begins on January 1, 2025, and ends on December 31, 2029, unless amended by written agreement or terminated earlier under the provisions.

**2. TIME OF BEGINNING AND COMPLETION.**

The Contractor shall begin the work outlined in the "Scope of Work" ("Work") on the beginning date, above. The City will acknowledge in writing when the Work is complete. Time limits established under this Agreement shall not be extended because of delays for which the Contractor is responsible, but may be extended by the City, in writing, for the City's convenience or conditions beyond the Contractor's control.

**3. SCOPE OF WORK.**

The Contractor's General Scope of Work for this Agreement is described in the City's ITB 6185-24 and Contractor's Response which is attached as **Attachment C** and made a part of this Agreement. In the event of a conflict or discrepancy in the Agreement documents, this City Agreement controls.

The Work is subject to City review and approval. The Contractor shall confer with the City periodically and prepare and present information and materials (e.g. detailed outline of completed Work) requested by the City to determine the adequacy of the Work or Contractor's progress.

**4. COMPENSATION / PAYMENT.**

Total compensation for Contractor's services under this Agreement shall be a maximum amount not to exceed **FOUR HUNDRED THIRTY THOUSAND AND NO/100 DOLLARS (\$430,000.00)**, plus applicable taxes, unless modified by a written amendment to this Agreement. This is the maximum amount to be paid under this Agreement for the work described in Section 3 above and

shall not be exceeded without the prior written authorization of the City in the form of an executed amendment to this Agreement.

The Contractor shall submit its applications for payment to Spokane Solid Waste Disposal, 2900 South Geiger Blvd., Spokane, Washington 99224. All invoices should include the City Clerk's File No. "OPR #2024-XXXX" and an approved L & I Intent to Pay Prevailing Wage number. The final invoice should include an approved Affidavit of Wages Paid number. Payment will not be made without this documentation included on the invoice. **Payment will be made via direct deposit/ACH** within thirty (30) days after receipt of the Company's application except as provided by state law. If the City objects to all or any portion of the invoice, it shall notify the Company and reserves the right to only pay that portion of the invoice not in dispute. In that event, the parties shall immediately make every effort to settle the disputed amount.

**5. LIQUIDATED DAMAGES.** Liquidated damages shall be in accordance with the contract documents.

**6. TAXES, FEES AND LICENSES.**

- A. Contractor shall pay and maintain in current status, all necessary licenses, fees, assessments, permit charges, etc. necessary to conduct the work included under this Agreement. It is the Contractor's sole responsibility to monitor and determine changes or the enactment of any subsequent requirements for said fees, assessments, or changes and to immediately comply.
- B. The cost of any permits, licenses, fees, etc. arising as a result of the projects included in this Agreement shall be included in the project budgets.

**7. PREVENTATIVE MAINTENANCE.**

The following Preventative Maintenance requirements apply to the Work under this Agreement:

- A. The Contractor shall pay state prevailing wages. The Contractor and all subcontractors will submit a "Statement of Intent to Pay Prevailing Wages," certified by the industrial statistician of the Department of Labor and Industries, prior to any payments. The "Statement of Intent to Pay Prevailing Wages" shall include: (1) the Contractor's registration number; and (2) the prevailing wages under RCW 39.12.020 and the number of workers in each classification. Each voucher claim submitted by a Contractor for payment on a project estimate shall state that the prevailing wages have been paid in accordance with the pre-filed statement or statements of intent to pay prevailing wages on file with the City. At the end of the work, the Contractor and subcontractors must submit an "Affidavit of Wages Paid," certified by the industrial statistician.
- B. **STATEMENT OF INTENT TO PAY PREVAILING WAGES TO BE POSTED.** For contracts in excess of \$10,000, the Contractor and each subcontractor required to pay the prevailing rate of wages shall post in a location readily visible at the job site: (1) a copy of a "Statement of Intent to Pay Prevailing Wages" approved by the industrial statistician of the Washington State Department of Labor and Industries (L & I); and (2) the address and telephone number of the industrial statistician of the Department of Labor and Industries where a complaint or inquiry concerning prevailing wages may be made.
- C. A payment/performance bond is NOT required.
- D. Statutory retainage is NOT required.

**8. CITY OF SPOKANE BUSINESS LICENSE.**

Section 8.01.070 of the Spokane Municipal Code states that no person may engage in business with the City without first having obtained a valid annual business registration. The Contractor shall be responsible for contacting the State of Washington Business License Services at [www.dor.wa.gov](http://www.dor.wa.gov) or 360-705-6741 to obtain a business registration. If the Contractor does not believe it is required to obtain a business registration, it may contact the City's Taxes and Licenses Division at (509) 625-6070 to request an exemption status determination.

**9. SOCIAL EQUITY REQUIREMENTS / NON-DISCRIMINATION.**

No individual shall be excluded from participation in, denied the benefit of, subjected to discrimination under, or denied employment in the administration of or in connection with this Agreement because of age, sex, race, color, religion, creed, marital status, familial status, sexual orientation including gender expression or gender identity, national origin, honorably discharged veteran or military status, the presence of any sensory, mental or physical disability, or use of a service animal by a person with disabilities. The Contractor agrees to comply with, and to require that all subcontractors comply with, federal, state and local nondiscrimination laws, including but not limited to: the Civil Rights Act of 1964, the Rehabilitation Act of 1973, the Age Discrimination in Employment Act, and the American's With Disabilities Act, to the extent those laws are applicable.

**10. INDEMNIFICATION.**

The Contractor shall defend, indemnify, and hold the City and its officers and employees harmless from all claims, demands, or suits at law or equity-asserted by third parties for bodily injury (including death) and/or property damage which arise from the Contractor's negligence or willful misconduct under this Agreement, including attorneys' fees and litigation costs; provided that nothing herein shall require a Contractor to indemnify the City against and hold harmless the City from claims, demands or suits based solely upon the negligence of the City, its agents, officers, and employees. If a claim or suit is caused by or results from the concurrent negligence of the Contractor's agents or employees and the City, its agents, officers and employees, this indemnity provision shall be valid and enforceable to the extent of the negligence of the Contractor, its agents or employees. The Contractor specifically assumes liability and agrees to defend, indemnify, and hold the City harmless for actions brought by the Contractor's own employees against the City and, solely for the purpose of this indemnification and defense, the Contractor specifically waives any immunity under the Washington State industrial insurance law, or Title 51 RCW. The Consultant/Contractor/Company recognizes that this waiver was specifically entered into pursuant to the provisions of RCW 4.24.115 and was the subject of mutual negotiation. The indemnity and agreement to defend and hold the City harmless provided for in this section shall survive any termination or expiration of this agreement.

**10. INSURANCE.**

During the period of the Contract, the Contractor shall maintain in force at its own expense, each insurance noted below with companies or through sources approved by the State Insurance Commissioner pursuant to Title 48 RCW:

A. **Worker's Compensation Insurance** in compliance with RCW 51.12.020, which requires subject employers to provide workers' compensation coverage for all their subject workers and Employer's Liability Insurance in the amount of \$1,000,000;

B. **General Liability Insurance** on an occurrence basis, with a combined single limit of not less than \$1,000,000 each occurrence for bodily injury and property damage. It shall include contractual liability coverage for the indemnity provided under this Contract. It shall provide that

the City, its officers and employees are additional insureds but only with respect to the Contractor's services to be provided under this Contract;

i. Acceptable supplementary Umbrella coverage in combination with Commercial General Liability policy shall be a minimum of \$2M in order to meet the minimum insurance coverages required under this contract; and

C. **Automobile Liability Insurance** with a combined single limit, or the equivalent of not less than \$1,000,000 each accident for bodily injury and property damage, including coverage for owned, hired and non-owned vehicles; and

D. **Property Insurance** if materials and supplies are furnished by the Contractor. The amount of the insurance coverage shall be the value of the materials and supplies of the completed value of improvement. Hazard or XCU (explosion, collapse, underground) insurance should be provided if any hazard exists.

There shall be no cancellation, material change, reduction of limits or intent not to renew the insurance coverage(s) without thirty (30) days written notice from the Consultant or its insurer(s) to the City. As evidence of the insurance coverage(s) required by this Agreement, the Consultant shall furnish acceptable Certificates of Insurance (COI) to the City at the time it returns this signed Agreement. The certificate shall specify the City of Spokane as "Additional Insured" specifically for Consultant's services under this Agreement, as well as all of the parties who are additional insureds, and include applicable policy endorsements, the thirty (30) day cancellation clause, and the deduction or retention level. The Consultant shall be financially responsible for all pertinent deductibles, self-insured retentions, and/or self-insurance.

#### **11. SUBCONTRACTOR RESPONSIBILITY.**

The Contractor must verify responsibility criteria for each first-tier subcontractor, and a subcontractor of any tier that hires other subcontractors must verify responsibility criteria for each of its subcontractors. Verification shall include that each subcontractor, at the time of subcontract execution, meets the responsibility criteria listed in RCW 39.04.350(1) and possesses an electrical contractor license, if required by chapter 19.28 RCW, or an elevator contractor license, if required by chapter 70.87 RCW.

#### **12. INDEPENDENT CONTRACTOR.**

The Contractor is an independent Contractor. This Agreement does not intend the Contractor to act as a City employee. The City has neither direct nor immediate control over the Contractor nor the right to control the manner or means by which the Contractor works. Neither the Contractor nor any Contractor employee shall be an employee of the City. This Agreement prohibits the Contractor to act as an agent or legal representative of the City. The Contractor is not granted express or implied rights or authority to assume or create any obligation or responsibility for or in the name of the City, or to bind the City. The City is not liable for or obligated to pay sick leave, vacation pay, or any other benefit of employment, nor to pay social security or other tax that may arise from employment. The Contractor shall pay all income and other taxes as due.

#### **13. ASSIGNMENT AND SUBCONTRACTING.**

The Contractor shall not assign or subcontract its obligations under this Agreement without the City's written consent, which may be granted or withheld in the City's sole discretion. Any subcontract made by the Contractor shall incorporate by reference this Agreement, except as otherwise provided. The Contractor shall ensure that all subcontractors comply with the obligations and requirements of the subcontract. The City's consent to any assignment or subcontract does not release the Contractor from liability or any obligation within this Agreement, whether before or after City consent, assignment or subcontract.

**14. TERMINATION.**

Either party may terminate this Agreement, with or without cause, by ten (10) days written notice to the other party. In the event of such termination, the City shall pay the Contractor for all work previously authorized and performed prior to the termination date.

**15. STANDARD OF PERFORMANCE.**

The standard of performance applicable to Contractor's services will be the degree of skill and diligence normally employed by professional contractors in the region performing the same or similar Contracting services at the time the work under this Agreement are performed.

**16. ANTI KICK-BACK.**

No officer or employee of the City of Spokane, having the power or duty to perform an official act or action related to this Agreement shall have or acquire any interest in the Agreement, or have solicited, accepted or granted a present or future gift, favor, service or other thing of value from or to any person involved in this Agreement.

**17. CONSTRUAL.**

The Contractor acknowledges receipt of a copy of the Agreement documents and agrees to comply with them. The silence or omission in the Agreement documents concerning any detail required for the proper execution and completion of the work means that only the best general practice is to prevail and that only material and workmanship of the best quality are to be used. This Contract shall be construed neither in favor of nor against either party.

**18. DEBARMENT AND SUSPENSION.**

The Contractor has provided its certification that it is in compliance with and shall not contract with individuals or organizations which are debarred, suspended, or otherwise excluded from or ineligible from participation in Federal Assistance Programs under Executive Order 12549 and "Debarment and Suspension", codified at 29 CFR part 98.

**19. CONTRACTOR'S ACKNOWLEDGEMENT AND WARRANTY.**

The Contractor acknowledges that it has visited the site of the work, has examined it, and is qualified to perform the work required by this Agreement.

The Contractor guarantees and warranties all work, labor and materials under this Agreement for one (1) year following final acceptance. If any unsatisfactory condition or defect develops within that time, the Contractor will immediately place the work in a condition satisfactory to the City and repair all damage caused by the condition or defect. The Contractor will repair or restore to the City's satisfaction, in accordance with the contract documents and at its expense, all property damaged by his performance under this Agreement. This warranty is in addition to any manufacturers' or other warranty in the Agreement documents.

**20. MISCELLANEOUS PROVISIONS.**

- A. **Amendments/Modifications:** The City may modify this Agreement and order changes in the work whenever necessary or advisable. The Contractor will accept modifications when ordered in writing by the City, and the Agreement time and compensation will be adjusted accordingly.
- B. The Contractor, at no expense to the City, shall comply with all laws of the United States and Washington, the Charter and ordinances of the City of Spokane; and rules, regulations, orders and directives of their administrative agencies and officers.
- C. This Agreement shall be construed and interpreted under the laws of Washington. The venue of any action brought shall be in a court of competent jurisdiction, located in Spokane County, Washington.



- D. **Captions:** The titles of sections or subsections are for convenience only and do not define or limit the contents.
- E. **Severability:** If any term or provision is determined by a court of competent jurisdiction to be invalid or unenforceable, the remainder of this Agreement shall not be affected, and each term and provision shall be valid and enforceable to the fullest extent permitted by law.
- F. **Waiver:** No covenant, term or condition or the breach shall be deemed waived, except by written consent of the party against whom the waiver is claimed, and any waiver of the breach of any covenant, term or condition shall not be deemed a waiver of any preceding or succeeding breach of the same or any other covenant, term of condition. Neither the acceptance by the City of any performance by the Contractor after the time the same shall have become due nor payment to the Contractor for any portion of the Work shall constitute a waiver by the City of the breach or default of any covenant, term or condition unless otherwise expressly agreed to by the City in writing.
- G. **Entire Agreement:** This document along with any exhibits and all attachments, and subsequently issued addenda, comprises the entire agreement between the City and the Contractor. If conflict occurs between Agreement documents and applicable laws, codes, ordinances or regulations, the most stringent or legally binding requirement shall govern and be considered a part of this Agreement to afford the City the maximum benefits.
- H. **No personal liability:** No officer, agent or authorized employee of the City shall be personally responsible for any liability arising under this Agreement, whether expressed or implied, nor for any statement or representation made or in any connection with this Agreement.
- I. Under Washington State Law (reference RCW Chapter 42.56, the *Public Records Act* [PRA]) all materials received or created by the City of Spokane are **public records** and are available to the public for viewing via the City Clerk's Records (online) or a valid Public Records Request (PRR).

IN WITNESS WHEREOF, in consideration of the terms, conditions and covenants contained, or attached and incorporated and made a part, the parties have executed this Agreement by having legally-binding representatives affix their signatures below.

**WEMCO, INC.**

**CITY OF SPOKANE**

By \_\_\_\_\_  
Signature Date

By \_\_\_\_\_  
Signature Date

\_\_\_\_\_  
Type or Print Name

\_\_\_\_\_  
Type or Print Name

\_\_\_\_\_  
Title

\_\_\_\_\_  
Title

Attest:

Approved as to form:

---

City Clerk

---

Assistant City Attorney

**Attachments that are part of this Agreement:**

Attachment A – Debarment Certification

Attachment B - Certification of Compliance with Wage Payment Statutes

Attachment C – Contractor’s Response to ITB 6184-24

24-202

**ATTACHMENT A**

**CERTIFICATION REGARDING DEBARMENT, SUSPENSION,  
INELIGIBILITY AND VOLUNTARY EXCLUSION**

1. The undersigned (i.e., signatory for the Subrecipient / Contractor / Consultant) certifies, to the best of its knowledge and belief, that it and its principals:
  - a. Are not presently debarred, suspended, proposed for debarment, declared ineligible, or voluntarily excluded from covered transactions by any federal department or agency;
  - b. Have not within a three-year period preceding this contract been convicted or had a civil judgment rendered against them for commission of fraud or a criminal offense in connection with obtaining, attempting to obtain, or performing a public (federal, state, or local) transaction or contract under a public transaction; violation of federal or state antitrust statutes or commission of embezzlement, theft, forgery, bribery, falsification or destruction of records, making false statements, tax evasion, receiving stolen property, making false claims, or obstruction of justice;
  - c. Are not presently indicted or otherwise criminally or civilly charged by a government entity (federal, state, or local) with commission of any of the offenses enumerated in paragraph (1)(b) of this certification; and,
  - d. Have not within a three-year period preceding this contract had one or more public transactions (federal, state, or local) terminated for cause or default.
  
2. The undersigned agrees by signing this contract that it shall not knowingly enter into any lower tier covered transaction with a person who is debarred, suspended, declared ineligible, or voluntarily excluded from participation in this covered transaction.
  
3. The undersigned further agrees by signing this contract that it will include the following clause, without modification, in all lower tier covered transactions and in all solicitations for lower tier covered transactions:

Certification Regarding Debarment, Suspension, Ineligibility and Voluntary Exclusion – Lower Tier Covered Transactions

1. The lower tier contractor certified, by signing this contract that neither it nor its principals is presently debarred, suspended, proposed for debarment, declared ineligible, or voluntarily excluded from participation in this transaction by any federal department or agency.
  
  2. Where the lower tier contractor is unable to certify to any of the statements in this contract, such contractor shall attach an explanation to this contract.
4. I understand that a false statement of this certification may be grounds for termination of the contract.

_____ Name of Subrecipient / Contractor / Consultant (Type or Print)	_____ Program Title (Type or Print)
_____ Name of Certifying Official (Type or Print)	_____ Signature
_____ Title of Certifying Official (Type or Print)	_____ Date (Type or Print)



**ATTACHMENT B**

**Certification of Compliance with Wage Payment Statutes and Washington Department of Labor and Industries Training Requirement**

The bidder hereby certifies that, within the three-year period immediately preceding the bid solicitation date (\_\_\_\_\_), the bidder is not a “willful” violator, as defined in RCW 49.48.082, of any provision of chapters 49.46, 49.48, or 49.52 RCW, as determined by a final and binding citation and notice of assessment issued by the Department of Labor and Industries or through a civil judgment entered by a court of limited or general jurisdiction.

As of July 1, 2019, have fulfilled the Department of Labor and Industries’ Public Works and Prevailing Wage Training Requirement before bidding and/or performing work on public works projects under RCW 39.04.350 and RCW 39.06.020 by either of the following:

- 1) Received training on the requirements related to public works and prevailing wage under chapter RCW 39.04.350 and chapter 39.12; or
- 2) Be certified exempt by the Department of Labor and Industries by having completed three or more public work projects and have a had a valid business license in Washington for three or more years.

I certify under penalty of perjury under the laws of the State of Washington that the foregoing is true and correct.

\_\_\_\_\_  
Bidder’s Business Name

\_\_\_\_\_  
Signature of Authorized Official\*

\_\_\_\_\_  
Printed Name

\_\_\_\_\_  
Title

\_\_\_\_\_  
Date

\_\_\_\_\_  
City

\_\_\_\_\_  
State

Check One:

Sole Proprietorship  Partnership  Joint Venture  Corporation

State of Incorporation, or if not a corporation, State where business entity was formed:

\_\_\_\_\_  
If a co-partnership, give firm name under which business is transacted:

\_\_\_\_\_

*\* If a corporation, proposal must be executed in the corporate name by the president or vice-president (or any other corporate officer accompanied by evidence of authority to sign). If a co-partnership, proposal must be executed by a partner.*

**ATTACHMENT C**



< Business Lookup

### License Information:

[New search](#) [Back to results](#)

**Entity name:** WASHINGTON EQUIPMENT MANUFACTURING COMPANY, INC.

**Business name:** WASHINGTON EQUIPMENT MANUFACTURING COMPANY, INC.

**Entity type:** [Profit Corporation](#)

**UBI #:** 601-174-038

**Business ID:** 001

**Location ID:** 0001

**Location:** Active

**Location address:** 5510 W THORPE RD  
SPOKANE WA 99224-5371

**Mailing address:** 5510 W THORPE RD  
SPOKANE WA 99224-5371

**Excise tax and reseller permit status:** [Click here](#)

**Secretary of State status:** [Click here](#)

### Endorsements

Endorsements held at this location	License #	Count	Details	Status	Expiration date	First issuance date
<a href="#">Minor Work Permit</a>				Active	Apr-30-2025	Feb-24-2020
<a href="#">Moses Lake General Business - Non-Resident</a>	BUS2020-0349			Active	Apr-30-2025	May-18-2020
<a href="#">Spokane General Business - Non-Resident</a>	T12003901BUS			Active	Apr-30-2025	Oct-15-2012

### Governing People May include governing people not registered with Secretary of State

Governing people	Title
ROUSE, JOHN	
ROUSE, JUSTON	
ROUSE, KARMA	
TURNER, MATTHEW	

### Registered Trade Names

Registered trade names	Status	First issued
WEMCO INC	Active	May-02-1989

The Business Lookup information is updated nightly. Search date and time: 10/2/2024 1:59:11 PM

[Contact us](#)

How are we doing?  
[Take our survey!](#)

Don't see what you expected?  
[Check if your browser is supported](#)





# CERTIFICATE OF LIABILITY INSURANCE

DATE (MM/DD/YYYY)

4/30/2024

THIS CERTIFICATE IS ISSUED AS A MATTER OF INFORMATION ONLY AND CONFERS NO RIGHTS UPON THE CERTIFICATE HOLDER. THIS CERTIFICATE DOES NOT AFFIRMATIVELY OR NEGATIVELY AMEND, EXTEND OR ALTER THE COVERAGE AFFORDED BY THE POLICIES BELOW. THIS CERTIFICATE OF INSURANCE DOES NOT CONSTITUTE A CONTRACT BETWEEN THE ISSUING INSURER(S), AUTHORIZED REPRESENTATIVE OR PRODUCER, AND THE CERTIFICATE HOLDER.

**IMPORTANT:** If the certificate holder is an ADDITIONAL INSURED, the policy(ies) must have ADDITIONAL INSURED provisions or be endorsed. If SUBROGATION IS WAIVED, subject to the terms and conditions of the policy, certain policies may require an endorsement. A statement on this certificate does not confer rights to the certificate holder in lieu of such endorsement(s).

<b>PRODUCER</b> Hub International Northwest LLC PO Box 3144 Spokane, WA 99220	<b>CONTACT NAME:</b> Stacia Simpson <b>PHONE (A/C, No, Ext):</b> (509) 319-2912 <b>FAX (A/C, No):</b>	
	<b>E-MAIL ADDRESS:</b> Stacia.Simpson@hubinternational.com	
<b>INSURER(S) AFFORDING COVERAGE</b>		<b>NAIC #</b>
<b>INSURED</b>  WEMCO, Inc. 5510 W Thorpe Road Spokane, WA 99224	<b>INSURER A :</b> Berkley Specialty Insurance Company	<b>31295</b>
	<b>INSURER B :</b> Alaska National Insurance Company	<b>38733</b>
	<b>INSURER C :</b> Navigators Specialty Insurance Company	<b>36056</b>
	<b>INSURER D :</b>	
	<b>INSURER E :</b>	
	<b>INSURER F :</b>	

**COVERAGES** **CERTIFICATE NUMBER:** **REVISION NUMBER:**

THIS IS TO CERTIFY THAT THE POLICIES OF INSURANCE LISTED BELOW HAVE BEEN ISSUED TO THE INSURED NAMED ABOVE FOR THE POLICY PERIOD INDICATED. NOTWITHSTANDING ANY REQUIREMENT, TERM OR CONDITION OF ANY CONTRACT OR OTHER DOCUMENT WITH RESPECT TO WHICH THIS CERTIFICATE MAY BE ISSUED OR MAY PERTAIN, THE INSURANCE AFFORDED BY THE POLICIES DESCRIBED HEREIN IS SUBJECT TO ALL THE TERMS, EXCLUSIONS AND CONDITIONS OF SUCH POLICIES. LIMITS SHOWN MAY HAVE BEEN REDUCED BY PAID CLAIMS.

INSR LTR	TYPE OF INSURANCE	ADDL INSD	SUBR WVD	POLICY NUMBER	POLICY EFF (MM/DD/YYYY)	POLICY EXP (MM/DD/YYYY)	LIMITS	
A	<b>COMMERCIAL GENERAL LIABILITY</b> <input type="checkbox"/> CLAIMS-MADE <input checked="" type="checkbox"/> OCCUR  GEN'L AGGREGATE LIMIT APPLIES PER: <input type="checkbox"/> POLICY <input checked="" type="checkbox"/> PROJECT <input type="checkbox"/> LOC OTHER:	X	X	CGL003439336	5/1/2024	5/1/2025	EACH OCCURRENCE	\$ 1,000,000
							DAMAGE TO RENTED PREMISES (Ea occurrence)	\$ 100,000
							MED EXP (Any one person)	\$ 5,000
							PERSONAL & ADV INJURY	\$ 1,000,000
							GENERAL AGGREGATE	\$ 2,000,000
							PRODUCTS - COMP/OP AGG	\$ 2,000,000
							<b>WA STOP GAP</b>	\$ 1,000,000
B	<b>AUTOMOBILE LIABILITY</b> <input checked="" type="checkbox"/> ANY AUTO OWNED AUTOS ONLY <input type="checkbox"/> SCHEDULED AUTOS <input checked="" type="checkbox"/> HIRED AUTOS ONLY <input checked="" type="checkbox"/> NON-OWNED AUTOS ONLY	X	X	24EAS08952	5/1/2024	5/1/2025	COMBINED SINGLE LIMIT (Ea accident)	\$ 1,000,000
							BODILY INJURY (Per person)	\$
							BODILY INJURY (Per accident)	\$
							PROPERTY DAMAGE (Per accident)	\$
C	<b>UMBRELLA LIAB</b> <input checked="" type="checkbox"/> OCCUR <b>EXCESS LIAB</b> <input type="checkbox"/> CLAIMS-MADE DED <input type="checkbox"/> RETENTION \$	X	X	SE24EXCZ01Y6BIC	5/1/2024	5/1/2025	EACH OCCURRENCE	\$ 5,000,000
							AGGREGATE	\$ 5,000,000
								\$
	<b>WORKERS COMPENSATION AND EMPLOYERS' LIABILITY</b> ANY PROPRIETOR/PARTNER/EXECUTIVE OFFICER/MEMBER EXCLUDED? (Mandatory in NH) <input type="checkbox"/> Y / N If yes, describe under DESCRIPTION OF OPERATIONS below		N / A				PER STATUTE	\$
							OTH-ER	\$
							E.L. EACH ACCIDENT	\$
							E.L. DISEASE - EA EMPLOYEE	\$
							E.L. DISEASE - POLICY LIMIT	\$
B	Installation Floater			24EIA08952	5/1/2024	5/1/2025	COC Limit	1,000,000

DESCRIPTION OF OPERATIONS / LOCATIONS / VEHICLES (ACORD 101, Additional Remarks Schedule, may be attached if more space is required)  
PROJECT: PW ITB 5101-19 REFUSE CRANES QUARTERLY PREVENTIVE MAINTENANCE INSPECTIONS AND UNSCHEDULED SERVICES FOR TWO 9-TON, TOP RUNNING DOUBLE GRINDER (TRDG) BRIDGE CRANES

THE CITY OF SPOKANE, ITS OFFICERS AND EMPLOYEES ARE ADDITIONAL INSURED AS RESPECTS TO THE GENERAL & AUTO LIABILITY & WAIVER OF SUBROGATION IS GRANTED AS IT RELATES TO THE GENERAL & AUTO LIABILITY WITH THE TERMS AND CONDITIONS OF THE POLICIES. UMBRELLA FOLLOWS FORMS. THE COVERAGE IS PRIMARY AND NON-CONTRIBUTORY WHERE REQUIRED BY A WRITTEN CONTRACT.

<b>CERTIFICATE HOLDER</b>  CITY OF SPOKANE 2900 S GEIGER BLVD. ATTN: MICHELLE DORGAN SPOKANE, WA 99224	<b>CANCELLATION</b>  SHOULD ANY OF THE ABOVE DESCRIBED POLICIES BE CANCELLED BEFORE THE EXPIRATION DATE THEREOF, NOTICE WILL BE DELIVERED IN ACCORDANCE WITH THE POLICY PROVISIONS.  AUTHORIZED REPRESENTATIVE 
---	--



# WAIVER OF TRANSFER OF RIGHTS OF RECOVERY AGAINST OTHERS TO US

This endorsement modifies insurance provided under the following:

COMMERCIAL GENERAL LIABILITY COVERAGE PART  
PRODUCTS/COMPLETED OPERATIONS LIABILITY COVERAGE PART

## SCHEDULE

**Name Of Person Or Organization:**

All Persons or Organizations when such Waiver is required by written contract with you and executed prior to the occurrence of the injury or damage for which we make payments on your behalf.

Information required to complete this Schedule, if not shown above, will be shown in the Declarations.

The following is added to Paragraph 8. **Transfer Of Rights Of Recovery Against Others To Us** of Section IV – Conditions:

We waive any right of recovery we may have against the person or organization shown in the Schedule above because of payments we make for injury or damage arising out of your ongoing operations or "your work" done under a contract with that person or organization and included in the "products-completed operations hazard". This waiver applies only to the person or organization shown in the Schedule above.

THIS ENDORSEMENT CHANGES THE POLICY. PLEASE READ IT CAREFULLY.

**ADDITIONAL INSURED - PRIMARY AND NONCONTRIBUTORY -  
AUTOMATIC STATUS WHEN REQUIRED IN A WRITTEN CONTRACT OR  
AGREEMENT  
(Including Completed Operations)**

This endorsement modifies insurance provided under the following:

COMMERCIAL GENERAL LIABILITY COVERAGE PART

**SCHEDULE**

**Date:** 5/1/2023

**A. Section II - Who Is An Insured is amended** to include as an additional insured any person or organization for whom you are performing operations when you and such person or organization have agreed in writing in a contract or agreement that such person or organization be added as an additional insured on your policy. Such person or organization is an additional insured only with respect to liability for "bodily injury", "property damage" or "personal and advertising injury" caused, in whole or in part, by:

1. Your acts or omissions, or the acts or omissions of those acting on your behalf in the performance of your ongoing operations for the additional insured; or
2. "Your work" and included in the "products-completed operations hazard".

but only for "occurrences" or coverages not otherwise excluded in the Coverage Part to which this endorsement applies.

However the insurance afforded to such additional insured:

1. Only applies to the extent permitted by law; and
2. Will not be broader than that which you are required by the contract or agreement to provide for such additional insured.

**B.** Status as an additional insured for the person or organization to which this endorsement applies commences during the policy period and after such written contract or agreement has been executed.

**C.** With respect to the insurance afforded to the additional insured, the following additional exclusions apply:

This insurance does not apply to:

1. "Bodily injury", "property damage", "personal and advertising injury" or medical payments arising out of the rendering of, or the failure to render, any professional architectural, engineering or surveying services, including:
  - a. The preparing, approving, or failure to prepare or approve, maps, shop drawings, opinions, reports, surveys, field orders, change orders or drawings and specifications; or
  - b. Supervisory, inspection, architectural or engineering activities.

This exclusion applies even if the claims against any insured allege negligence or other wrongdoing in the supervision, hiring, employment, training or monitoring of others by that insured, if the "occurrence" which caused the "bodily injury" or "property damage", or the offense which caused the "personal and advertising injury", involved the rendering of or the failure to render any professional architectural, engineering, or surveying services.

2. "Bodily injury" or "property damage" included in the "products-completed operations hazard" and arising out of "your work" that was completed by or on behalf of any insured prior to the date shown in the Schedule of this endorsement.

**D. With respect to the insurance afforded to the additional insured, the following is added to **Section III – Limits Of Insurance:****

The most we will pay on behalf of the additional insured is the amount of insurance:

1. Required by the contract or agreement you have entered into with the additional insured; or
2. Available under the applicable limits of insurance;

whichever is less.

This endorsement shall not increase the applicable limits of insurance.

**E. The following condition is added to 4.a. of **Other Insurance** of **Section IV - Commercial General Liability Conditions:****

If required in a written contract, the Coverage Part to which this endorsement applies is primary and noncontributory in the event of an "occurrence" caused, in whole or in part, by your acts or omissions, or the acts or omissions of those acting on your behalf that:

1. Occurs while performing ongoing operations for the additional insured, or
2. Is included in the "products-completed operations hazard" and arises out of "your work" that was completed by or on behalf of any insured after the date shown in the Schedule of this endorsement.

All other terms and conditions remain unchanged.

**THIS ENDORSEMENT CHANGES THE POLICY. PLEASE READ IT CAREFULLY.**

**AMENDMENT OF CONDITIONS  
OTHER INSURANCE  
PRIMARY AND NON-CONTRIBUTING**

This endorsement modifies insurance provided under the following:

COMMERCIAL EXCESS LIABILITY COVERAGE PART

SCHEDULE

When required by written contract executed before the "loss."

- A. Section IV - Conditions, 9. Other Insurance is deleted and replaced by the following:
  - 9. This insurance is excess over any other insurance available to the insured except:
    - a. insurance that is purchased specifically to apply in excess of this policy; or
    - b. insurance available to the person or organization shown in the Schedule of this endorsement as an additional insured on the "controlling underlying insurance."
- B. When this insurance applies on a primary and non-contributing basis, the Limits of Insurance available for the additional insured will be the lesser of:
  - 1. the amounts shown in item 3 of the Declarations of this policy; or
  - 2. the amount of insurance you are required to provide the additional insured in the written contract or agreement.

All other terms of the policy remain unchanged.

**SECTION II – WHO IS AN INSURED**

The WHO IS AN INSURED section of the “controlling underlying insurance” is made part of this policy. Any person or organization that is an insured in “controlling underlying insurance” is an insured in this policy to the same extent.

**SECTION III – LIMITS OF INSURANCE**

The Limits of Insurance shown in the Declarations and the rules below fix the most we will pay regardless of the number of insureds, claims made or suits brought, or persons or organizations making claims or bringing suits.

1. The General Aggregate Limit is the most we will pay for the sum of all damages to which this insurance applies, except:
  - a. damages because of bodily injury or property damage included within any applicable products-completed operations hazard; or
  - b. damages arising out of the ownership, operation, maintenance or use of an automobile;
2. The Products-Completed Operations Aggregate Limit is the most we will pay for the sum of all damages included within any applicable products-completed operations hazard;
3. Subject to paragraphs 1. and 2. above, the Each Event Limit is the most we will pay for all damages that arise out of any one “event.”

**SECTION IV – CONDITIONS**

The CONDITIONS sections of the “controlling underlying insurance” are made part of this policy. If an inconsistency or contradiction exists between the Conditions of this policy and the Conditions of the “controlling underlying insurance,” the Conditions of this policy will apply.

1. Appeals  
At our discretion we may appeal any judgment which would result in a payment under this policy. When we do appeal, we will pay all costs associated with the appeal in addition to the Limits of Insurance. Any such appeal will not increase our Limits of Insurance.
2. Bankruptcy or Insolvency  
Bankruptcy or insolvency of the insured or the insured's estate will not relieve us of our obligations under this policy. Bankruptcy or insolvency of any company providing “controlling underlying insurance” will not reduce the “underlying limits” or increase our obligations under this policy. We will not be required to drop down or replace “controlling underlying insurance.”
3. Cancellation
  - a. The first Named Insured may cancel this policy at any time by providing us advanced written notice of the cancellation date.
  - b. We may cancel this policy at any time by providing the first Named Insured written notice of cancellation:
    - i. at least 10 days in advance if we cancel for non-payment of premium; or
    - ii. at least 30 days in advance if we cancel for any other reason:

- d. No insured will, except at that insured's own cost, voluntarily make a payment, assume any obligation or incur any expense, other than first aid, without our consent. Notice to us may be sent to our address shown in the Declarations.
7. Legal Action Against Us  
No person or organization has a right under this insurance:
- to join us as a party or otherwise bring us into a suit asking for damages from an insured; or
  - to sue us on this insurance unless all of its terms have been fully complied with.
8. Maintenance of Controlling Underlying Insurance  
During the "policy period" you must maintain "controlling underlying insurance" with "underlying limits" at least equal to the amounts shown in the Declarations. The "underlying limits" must be unimpaired at the beginning of this "policy period." If you fail to maintain the "controlling underlying insurance" this policy will be invalid. If you fail to maintain "underlying limits," we will only be liable to the extent we would have been liable had you maintained the "underlying limits." Reduction of "underlying limits" by the payment of judgments or settlements for "loss" to which this insurance applies, or would have applied but for the amount of the damages, will not be considered a failure to maintain "underlying limits."
9. Other Insurance  
This insurance is excess over any insurance available to the insured except insurance purchased specifically to apply in excess of this policy.
10. Payment of Damages  
When the amount of damages payable under this policy has been determined by final judgment or a written settlement agreement between the claimant and us, we will pay that amount, up to our applicable Limits of Insurance, after the "controlling underlying insurance" or the insured has paid the full amount of the "underlying limits."
11. Premium  
The Premium shown in the Declarations is the premium for the coverage we provide for the "policy period." The first Named Insured is responsible for the payment of all premiums under this policy. If this policy is cancelled prior to its expiration date return premium will be calculated as follows:
- if cancelled by us:  
$$\{[(\text{Premium}) - (\text{Minimum Earned Premium})] \times (\text{Pro Rata factor})\}$$
  - if cancelled by you:  
$$\{[(\text{Premium}) - (\text{Minimum Earned Premium})] \times \{(\text{Pro Rata factor}) \times (.90)\}\}$$
12. Separation of Insureds  
Except with respect to the Limits of Insurance and any rights or duties specifically assigned in this policy to the first Named Insured, this insurance applies:
- as if each Named Insured were the only Named Insured; and
  - separately to each insured against whom claim is made or suit is brought.
13. Transfer of Rights of Recovery Against Others  
If an insured has rights to recover all or part of any payment we have made under this insurance, the insured must preserve those rights and, at our request, pursue or transfer those rights to us. The insured must do nothing after an "event" to impair them.

**THIS ENDORSEMENT CHANGES THE POLICY. PLEASE READ IT CAREFULLY.**

**CONSTRUCTION PROJECT GENERAL AGGREGATE LIMIT WHEN  
REQUIRED BY CONTRACT AND  
MAXIMUM PER POLICY GENERAL AGGREGATE LIMIT**

This Endorsement modifies insurance provided under the following:

**COMMERCIAL GENERAL LIABILITY COVERAGE PART**

**SCHEDULE**

**Limits of Insurance**

Maximum Per Policy General Aggregate Limit \$5,000,000

- A. For all sums which the insured becomes legally obligated to pay as damages caused by "occurrences" under **Section I - Coverage A - Bodily Injury And Property Damage Liability**, and for all medical expenses caused by accidents under **Section I - Coverage C - Medical Payments**, which can be attributed only to ongoing operations at a single construction project:
1. A separate Construction Project General Aggregate Limit applies to each construction project when required in a written construction contract or agreement, and that limit is equal to the amount of the General Aggregate Limit shown in the Declarations.
  2. The Construction Project General Aggregate Limit is the most we will pay for the sum of all damages under **Coverage A**, except damages because of "bodily injury" or "property damage" included in the "products-completed operations hazard", and for medical expenses under **Coverage C** regardless of the number of:
    - a. Insureds;
    - b. Claims made or "suits" brought; or
    - c. Persons or organizations making claims or bringing "suits".
  3. Any payments made under **Coverage A** for damages or under **Coverage C** for medical expenses shall reduce the Construction Project General Aggregate Limit for that construction project. Such payments shall not reduce the General Aggregate Limit shown in the Declarations nor shall they reduce any other Construction Project General Aggregate Limit for any other construction project.
  4. The limits shown in the Declarations for Each Occurrence, Damage To Premises Rented To You and Medical Expense continue to apply. However, instead of being subject to the General Aggregate Limit shown in the Declarations, such limits will be subject to the applicable Construction Project General Aggregate Limit.
  5. The Maximum Per Policy General Aggregate Limit shown in the Schedule is the most we will pay for the sum of all Construction Project General Aggregate Limits and the General Aggregate Limit shown in the Declarations regardless of the number of:
    - a. Insureds;
    - b. Claims made or "suits" brought;
    - c. Persons or organizations making claims or bringing "suits"; or
    - d. Construction projects.

- B. For all sums which the insured becomes legally obligated to pay as damages caused by "occurrences" under **Section I - Coverage A - Bodily Injury And Property Damage Liability**, and for all medical expenses caused by accidents under **Section I - Coverage C - Medical Payments**, which cannot be attributed only to ongoing operations at a single construction project:
  - 1. Any payments made under **Coverage A** for damages or under **Coverage C** for medical expenses shall reduce the amount available under the General Aggregate Limit shown in the Declarations or the Products-Completed Operations Aggregate Limit shown in the Declarations, whichever is applicable; and
  - 2. Such payments shall not reduce any Construction Project General Aggregate Limit.
- C. When coverage for liability arising out of the "products-completed operations hazard" is provided, any payments for damages because of "bodily injury" or "property damage" included in the "products-completed operations hazard" will reduce the Products-Completed Operations Aggregate Limit shown in the Declarations, and not reduce the General Aggregate Limit shown in the Declarations nor the Construction Project General Aggregate Limit.
- D. If the applicable construction project has been abandoned, delayed, or abandoned and then restarted, or if the authorized contracting parties deviate from plans, blueprints, designs, specifications, or timetables, the project will still be deemed to be the same construction project.
- E. The provisions of **Section III - Limits Of Insurance** not otherwise modified by this endorsement shall continue to apply as stipulated.

All other terms and conditions of this policy remain unchanged.



**THIS ENDORSEMENT CHANGES THE POLICY. PLEASE READ IT CAREFULLY.**

## **WAIVER OF SUBROGATION**

### **SCHEDULE**

**Name of Person or Organization:**

As required by written contract or agreement.

Information required to complete this Schedule, if not shown above, will be shown in the Declarations.

The following is added to SECTION IV - CONDITIONS, 13. Transfer of Rights of Recovery Against Others.

We waive any right of recovery we may have against the person or organization shown in the Schedule above because of payments we make for injury or damage arising out of your ongoing operations or "your work" done under a contract with that person or organization. This waiver applies only to the person or organization shown in the Schedule above.

All other terms of the policy remain unchanged.

---

**WAIVER OF OUR RIGHT TO RECOVER FROM OTHERS ENDORSEMENT**

---

We have the right to recover our payments from anyone liable for an injury covered by this policy. We will not enforce our right against the person or organization named in the Schedule. (This agreement applies only to the extent that you perform work under

a written contract that requires you to obtain this agreement from us.)

This agreement shall not operate directly or indirectly to benefit any one not named in the Schedule.

**SCHEDULE**

Any person or organization for whom the Insured has agreed by written contract to furnish this waiver.

This endorsement changes the policy to which it is attached and, unless otherwise stated, is effective on the date issued at 12:01 A.M. standard time at your mailing address shown in the policy. **The information below is required only when this endorsement is issued subsequent to commencement of the policy.**

Endorsement Effective 5/1/2024

Policy No. 24HWS08952

Insured WEMCO, Inc.

Endorsement No. 5

Countersigned By \_\_\_\_\_



---

**BUSINESS AUTO COVERAGE ENHANCEMENT ENDORSEMENT**

---

**THIS ENDORSEMENT CHANGES THE POLICY. PLEASE READ IT CAREFULLY.**

This endorsement modifies insurance provided under the following:

**BUSINESS AUTO COVERAGE FORM**

Various provisions in this endorsement restrict coverage. Read the entire policy carefully to determine rights, duties, and what is and is not covered.

Throughout this policy, the words "you" and "your" refer to the Named Insured shown in the Declarations. The words "we", "us", and "our" refer to the company providing this insurance.

Other words and phrases that appear in quotation marks have special meaning. Refer to **SECTION V – DEFINITIONS** in the Business Auto Coverage Form.

The coverages provided by this endorsement apply per "accident" and, unless otherwise specified, are subject to all of the terms, conditions, exclusions and deductible provisions of the policy, to which it is attached.

**SECTION II – COVERED AUTO LIABILITY COVERAGE**, Paragraph A.1. Who Is An Insured is amended to include:

- d. Any "employee" of yours while operating an "auto" hired or rented under a contract or agreement in an "employee's" name, with your permission, while performing duties related to the conduct of your business.
- e. Any person or organization for whom you have agreed in writing to provide insurance such as is afforded by this Coverage Form, but only with respect to liability arising out of the ownership, maintenance or use of "autos" covered by this policy. If such person or organization has other insurance then this insurance is primary to and we will not seek contribution from the other insurance.

**SECTION IV – Business Auto Conditions, Paragraph A. 5. – Transfer of Rights of Recovery Against Others To Us** is amended to include:

**5. Transfer of Rights of Recovery Against Others to Us**

This condition does not apply to any person(s) or organization(s) to the extent that subrogation against that person or organization is waived prior to the "accident" or the "loss" under a contract with that person or organization.

**SECTION II – COVERED AUTO LIABILITY COVERAGE**, Paragraph A.2.a. (2) – **Supplementary Payments** is replaced by the following:

- (2) Up to \$10,000 for cost of bail bonds (including bonds for related traffic law violations) required because of an "accident" we cover. We do not have to furnish these bonds.

**SECTION II – COVERED AUTO LIABILITY COVERAGE**, Paragraph A.2.a. (4) – **Supplementary Payments** is replaced by the following:

- (4) All reasonable expenses incurred by the "insured" at our request, including actual loss of earnings up to \$500 a day because of time off from work.

**SECTION II – COVERED AUTO LIABILITY COVERAGE**, Paragraph A.2.c. – **Voluntary Property Damage** is added as follows:

**c. Voluntary Property Damage**

At your written request, we may make a voluntary payment for Property Damage caused by an “insured”, but without liability to a third party, up to \$25,000. We will not make a Voluntary Property Damage payment to anyone who is an “insured” under this policy.

**SECTION III – PHYSICAL DAMAGE COVERAGE**, Paragraph A.2. – **Towing** is replaced by the following:

**Towing**

We will pay up to \$500 for towing and labor costs incurred each time a covered “auto” that is a:

- a. Private passenger;
- b. Truck;
- c. Pick-up truck;
- d. Panel ; or
- e. Van

type vehicle under 20,000 lbs. of Gross Vehicle Weight is disabled. However, the labor must be performed at place of disablement.

**SECTION III – PHYSICAL DAMAGE COVERAGE**, Paragraph A.3. – **Glass Breakage – Hitting a Bird or Animal – Falling Objects or Missiles** is replaced by the following:

**Glass Breakage – Hitting a Bird or Animal – Falling Objects or Missiles**

If you carry Comprehensive Coverage for the damaged covered “auto”, we will pay the following under Comprehensive Coverage:

- a. Glass Breakage;
- b. “Loss” caused by hitting a bird or animal; and

- c. “Loss” caused by falling objects or missiles.

However, you have the option of having glass breakage caused by a covered “auto’s” collision or overturn considered a “loss” under Collision Coverage.

**Glass Repair – Waiver of Deductible**

No deductible applies to glass breakage, if the glass is repaired rather than replaced.

**SECTION III – PHYSICAL DAMAGE COVERAGE**, Paragraph A.4.a. – **Transportation Expenses** is replaced by the following:

**a. Transportation Expenses**

We will pay up to \$200 per day to a maximum of \$1,500 for temporary transportation expense incurred by you because of the total theft of a covered “auto” that is a:

- (1) Private passenger;
- (2) Truck;
- (3) Pick-up truck;
- (4) Panel; or
- (5) Van

type vehicle under 20,000 lbs. of Gross Vehicle Weight. We will pay only for those covered “autos” for which you carry either Comprehensive or Specified Causes of Loss Coverage. We will pay for temporary transportation expenses incurred during the period beginning 48 hours after the theft and ending, regardless of the policy’s expiration, when the covered “auto” is returned to use or we pay for its “loss”.

**SECTION III – PHYSICAL DAMAGE COVERAGE,**  
Paragraph A.4.b. – **Loss of Use Expenses** is  
replaced by the following:

**b. Loss of Use Expenses – Hired, Rented,  
or Borrowed Automobiles**

We will pay expenses for which an  
“insured” becomes legally responsible to  
pay for loss of use of a vehicle hired,  
rented or borrowed without a driver under  
a written rental contract or agreement.  
We will pay for loss of use expenses, if  
caused by:

- (1) Other than Collision, only if the  
Declarations indicate that  
Comprehensive Coverage is provided  
for the vehicle withdrawn from  
service.
- (2) Specified Causes of Loss only if the  
Declarations indicate that Specified  
Causes of Loss Coverage is provided  
for the vehicle withdrawn from  
service.
- (3) Collision only if the Declarations  
indicate that Collision Coverage is  
provided for the vehicle withdrawn  
from service.

However, the most we will pay for any  
expenses for loss of use is \$200 per day, to a  
maximum of \$1,500.

**SECTION III – PHYSICAL DAMAGE COVERAGE,**  
Paragraph A.4.c. – **Non-Transportation Loss of Use  
Expenses** is added as follows:

**c. Non-Transportation Loss of Use  
Expenses**

We will pay up to \$2,000 for non-  
transportation expense incurred by you,  
because of “loss” to a covered “auto”, if  
caused by:

- (1) Other than Collision, only if the  
Declarations indicate that  
Comprehensive Coverage is provided  
for the “auto” withdrawn from service;

- (2) Specified Causes of Loss only if the  
Declarations indicate that Specified  
Causes of Loss Coverage is provided  
for the “auto” withdrawn from service;  
or
- (3) Collision only if the Declarations  
indicate that Collision Coverage is  
provided for the “auto” withdrawn  
from service.

**SECTION III – PHYSICAL DAMAGE COVERAGE,**  
Paragraph A.4.d. – **Airbag Coverage** is added as  
follows:

**d. Airbag Coverage**

We will pay for the cost to repair, replace,  
or reset an airbag that inflates for any  
reason other than as a result of a  
collision, if the Declarations indicate that  
the covered “auto” has Comprehensive  
Coverage or Specified Causes of Loss  
Coverage.

**SECTION III – PHYSICAL DAMAGE COVERAGE,**  
Paragraph A.4.e. – **Rental Reimbursement  
Coverage** is added as follows:

**e. Rental Reimbursement Coverage**

We will pay up to \$75 per day for rental  
reimbursement expenses incurred by you  
for the rental of an “auto” because of  
“loss” to a covered “auto” that is a:

- (1) Private Passenger;
- (2) Truck;
- (3) Pick-up truck;
- (4) Panel; or
- (5) Van

type vehicle under 20,000 lbs. of Gross  
Vehicle Weight. Payment applies in  
addition to the otherwise applicable  
amount of each coverage you have on a  
covered “auto”. No deductibles apply to  
this coverage.

- (1) We will pay only for those expenses incurred during the policy period beginning 24 hours after the "loss" and ending, regardless of the policy's expiration, with the lesser of the following number of days:
  - (a) The number of days reasonably required to repair or replace the covered "auto".
  - (b) 30 days.
- (2) This coverage does not apply while there are spare or reserve "autos" available to you for your operations.
- (3) The Rental Reimbursement Coverage described above does not apply to a covered "auto" that is described or designated as a covered "auto" on Rental Reimbursement Coverage Form CA 99 23.

**SECTION IV – BUSINESS AUTO CONDITIONS – Paragraph B.2. – Concealment, Misrepresentation Or Fraud is amended by adding **Unintentional Failure to Disclose Hazards** at the end of Paragraph B.2. as follows:**

**Unintentional Failure to Disclose Hazards**

If you unintentionally fail to disclose any hazards existing at the inception date of your policy, we will not deny coverage under this Coverage Form because of such failure. However, this provision does not affect our right to collect additional premium or exercise our right of cancellation or non-renewal.

**SECTION IV – BUSINESS AUTO CONDITIONS – Paragraph B.5.b. – Other Insurance** is replaced by the following:

- b. For Hired Auto Physical Damage Coverage, the following are deemed to be covered "autos" you own:
  - (1) Any covered "auto" you lease, hire, rent, or borrow; and
  - (2) Any covered "auto" hired or rented by your "employee" under a contract in that individual "employee's" name, with your permission, while performing duties related to the conduct of your business.

However, any "auto" that is leased, hired, rented or borrowed with a driver is not a covered "auto".

**SECTION V – DEFINITIONS – Paragraph C. – "Bodily injury"** is replaced by the following:

- C. "Bodily injury" means bodily injury, sickness or disease sustained by a person including death or mental anguish resulting from any of these. Mental anguish means any type of mental or emotional illness or disease

This endorsement changes the policy to which it is attached and, unless otherwise stated, is effective on the date issued at 12:01 A.M. standard time at your mailing address shown in the policy. **The information below is required only when this endorsement is issued subsequent to commencement of the policy.**

Endorsement Effective 5/1/2017

Policy No. 17EPS08952

Insured WEMCO, Inc.

Endorsement No. 3

Countersigned By \_\_\_\_\_

### Bid Response Summary

**Bid Number** ITB 6184-24  
**Bid Title** Quarterly Crane, Hoist, Trolley and Lifeline Preventative Maintenance Inspections and Services – Prevailing Wages  
**Due Date** Monday, September 30, 2024 1:00:00 PM [(UTC-08:00) Pacific Time (US & Canada)]  
**Bid Status** Closed to Bidding  
**Company** Wemco Inc.  
**Submitted By** Matt Humphrey - Monday, September 30, 2024 11:18:24 AM [(UTC-08:00) Pacific Time (US & Canada)]  
 mhumphrey@wemcoinc.com 5092444773  
**Comments**

#### Question Responses

Group	Reference Number	Question	Response
MANDATORY Pre-Bid			
	1	A MANDATORY pre-bid conference will be held on WEDNESDAY, SEPTEMBER 18, 2024, at 10:00 am. The location will be at the Waste to Energy Facility (WTEF) Admin Offices, 2900 S Geiger Blvd., Spokane WA. FIELD VERIFICATION REQUIRED. The Bidder is entirely responsible for inspecting all site conditions prior to submitting a service bid. This meeting is MANDATORY ONLY for those companies who have not previously performed Quarterly Crane, Hoist, Trolley and Lifeline Preventative Maintenance Inspections and Services at the City of Spokane Waste to Energy Facility.	Acknowledge
CONTACT INFORMATION			
	1	List the following information for the person submitting this response: Company Name, Name, Address, Telephone Number & e-mail address:	WEMCO Inc. Matt Humphrey 5510 West Thorpe Road Spokane, WA 99224 (509)998-5985 mhumphrey@wemcoinc.com
	2	Provide the name, phone number, and email address for the person in your Company that would potentially sign a contract through the DocuSign process used by the City	Matt Turner (590)999-9913 mturner@wemcoinc.com
TECHNICAL GROUP			
	1	Bidder acknowledges it has read and understands Bid # ITB 6184-24.	Acknowledge
	2	How Many Addenda Do You Acknowledge Receipt Of? Please Enter Number. If none were issued enter "0".	2
	3	Please Complete and Upload "Bid Proposal" Pages #15-18 of ITB 6184-24. Upload Here.	Bid Pricing Pages 15-18.pdf

4.	<p>The bid shall be accompanied by a copy of bid bond/bid security payable to the order of the City of Spokane, in an amount of not less than five percent (5%) of the total contract amount. Bid bonds must be by a surety company authorized to do business as a surety in Washington State. As soon as the bid prices have been compared, the City will release the bid security of all except the three (3) lowest responsible bidders. When the service agreement is signed and returned with proof of insurance, the other bid security will be released. If the bidder is awarded the contract and fails to enter into a contract and to provide proof of insurance within the required time period, the bid security shall be forfeited to the City of Spokane. (Blank form available under the 'Documents' tab). In addition to the bid deposit types included in this section, a bidder may have on file with the City Clerk an annual bid bond approved by the City Attorney.</p>	Acknowledge
4.1	<p>Please Complete and Upload "Bid Bond Form" – Page 19 of ITB 6184-24. Upload Here</p>	<p>Bid Bond - ITB 6184-24.pdf</p>
5	<p>Please Complete and Upload "Subcontractor List" – Page 20 of ITB 6184-24. Upload Here</p>	<p>Bid Pricing Page 20.pdf</p>
6	<p>Please Complete and Upload "Supplemental Bidder Responsibility Criteria Form With Work Experience Form" Pages #23 – 28 of ITB 6173-24. Upload Here</p>	<p>Bid Pricing Pages 23-28 - Signed - Final.pdf</p>
6.1	<p>Should Bidder not have provided 'Supplemental Bidder Responsibility Criteria Form With Work Experience Form" above, Bidder acknowledges after bid opening and prior to award, the apparent low bidder, or contacted bidders, shall complete, sign and submit this form with attached documentation within twenty four (24) hours of notification.</p>	<p>Acknowledge</p>
7	<p>Bidder acknowledges there may be a need for unscheduled, emergency services, in which case response time is critical and vendor must be on-site within 4 hours after notification.</p>	<p>Acknowledge</p>
8	<p>Acknowledge that that you have read and understand Liquidate Damages stated in the bid.</p>	<p>Acknowledge</p>
9	<p>If you took exception to any of the above, explain in detail.</p>	
<p><b>TERMS AND CONDITIONS</b></p>		



1	Bidder accepts the Terms and Conditions of this ITB in accordance with the document so named in the 'Documents' tab. Should Bidder have selected "Acknowledged With Exceptions" to acceptance of Terms and Conditions as set forth in ITB document so named in the 'Documents' tab, Bidder must submit requested exceptions document with its Bid. The City will consider and determine if exception will be accepted.	Acknowledged
1.1	EXCEPTION: If you took exception to above, upload here.	
2	ELIGIBILITY FOR CITY CONTRACTS: Section 18.09.050 of the Spokane Municipal Code states that the recipient of a City contract, award or purchase order shall certify that it is not knowingly or intentionally a nuclear weapons producer. The Bidder certifies that his/her firm is not a nuclear weapons producer.	I Certify
ADDITIONAL DOCUMENTS BIDDER WOULD LIKE TO UPLOAD		
1	ADDITIONAL DOCUMENTS BIDDER WOULD LIKE TO UPLOAD: Should Bidder Want To Upload Any Additional Document(s) Please Do So Here. ***Please Note: Should Bidder Want To Add More Than One Document, ensure all documents are combined into a single document prior to uploading as bidder would only be able to upload one document here.	Addendum 1 ITB 6184-24 - Signed.pdf
2	ADDITIONAL DOCUMENTS BIDDER WOULD LIKE TO UPLOAD: Should Bidder Want To Upload Any Additional Document(s) Please Do So Here. ***Please Note: Should Bidder Want To Add More Than One Document, ensure all documents are combined into a single document prior to uploading as bidder would only be able to upload one document here.	Addendum 2 ITB 6184-24 - Signed.PDF
3	ADDITIONAL DOCUMENTS BIDDER WOULD LIKE TO UPLOAD: Should Bidder Want To Upload Any Additional Document(s) Please Do So Here. ***Please Note: Should Bidder Want To Add More Than One Document, ensure all documents are combined into a single document prior to uploading as bidder would only be able to upload one document here..	WOSB Certification Certificate Expires 1-31-2025.pdf

4	<p>ADDITIONAL DOCUMENTS BIDDER WOULD LIKE TO UPLOAD: Should Bidder Want To Upload Any Additional Document(s) Please Do So Here. ***Please Note: Should Bidder Want To Add More Than One Document, ensure all documents are combined into a single document prior to uploading as bidder would only be able to upload one document here.</p>	<p>Safety Ratings - ITB 6184- 24.pdf</p>
---	---	--

**Addendum 1**  
**9/19/2024**

ITB 6184-24



**Quarterly Crane, Hoist, Trolley and Lifeline Preventative Maintenance Inspections and Services – Prevailing Wages**

**PLEASE NOTE: A SIGNED COPY OF THIS ADDENDUM SHOULD BE SUBMITTED WITH YOUR BID, OR THE BID MAY BE CONSIDERED NON-RESPONSIVE.**

Addendum 1 provides questions and responses that were asked during the Mandatory Pre-Bid Conference that was held Wednesday, September 18, 2024 at 10:00 am., at the Waste to Energy Facility (WTEF) Admin Offices, 2900 S Geiger Blvd., Spokane WA. The meeting was MANDATORY ONLY for those companies who have not previously performed Quarterly Crane, Hoist, Trolley and Lifeline Preventative Maintenance Inspections and Services at the City of Spokane Waste to Energy Facility.

Addendum also provides a copy of the sign-in sheet.

QUESTIONS: No questions were asked.

<b>ITB 6184-24, Quarterly Crane, Hoist, Trolley and Lifeline Preventative Maintenance Inspections and Services – Prevailing Wages</b>			
<b>MANDATORY PRE-BID CONFERENCE. A MANDATORY pre-bid conference held Wednesday, September 18, 2024 at 10:00 am., at the Waste to Energy Facility (WTEF) Admin Offices, 2900 S Geiger Blvd., Spokane WA. <u>The meeting was MANDATORY ONLY for those companies who have not previously performed Quarterly Crane, Hoist, Trolley and Lifeline Preventative Maintenance Inspections and Services at the City of Spokane Waste to Energy Facility.</u></b>			
Company Name	Individual's Printed Name	Signature	Email address
Whitney Equipment	Devek Nesbitt		dnesbitt@weci.com
WEMCO Inc	Matt Humphrey		Mhumphrey@wemcoinc.com

Rick Rinderle  
Procurement Specialist

The undersigned acknowledges receipt of this Addendum.

**WEMCO, Inc.**

Company

Matthew L Humphrey

Signature

Digitally signed by Matthew L. Humphrey  
DN: c=US, E=mhumphrey@wemcoinc.com,  
O=WEMCO Inc., CN=Matthew L. Humphrey  
Reason: I am approving this document  
Date: 2024.09.30 10:18:41-0700

**Addendum 2**  
**9/25/2024**

**ITB 6184-24**

**Quarterly Crane, Hoist, Trolley and Lifeline Preventative Maintenance Inspections and Services –  
Prevailing Wages**

**PLEASE NOTE: A SIGNED COPY OF THIS ADDENDUM SHOOULD BE SUBMITTED WITH YOUR BID, OR  
THE BID MAY BE CONSIDERED NON-RESPONSIVE.**

Addendum 2 make the following changes:

Addendum 2, ITB 6184-24, has been posted in the Documents tab, makes the following changes:  
**Bid Document “.ITB 6184-24 Document” 8/26/2024, has since been removed from the External Documents tab  
and replaced with titled document: “.ITB 6184-24 (Addendum 2 Bid Document) 9-25-2024, that made the one  
below change:**

**16. EXECUTION OF CONTRACT.** (Addendum 2, 9/25/2024)

Text Removed: ~~and payment/performance bonds~~

The undersigned acknowledges receipt of this Addendum.

**WEMCO, Inc.**

---

Company

Matthew L Humphrey

---

Signature

Digitally signed by Matthew L. Humphrey  
DN: C=US, E=mhumphrey@wemcoinc.com,  
O=WEMCO Inc., CN=Matthew L. Humphrey  
Reason: I am approving this document  
Date: 2024.09.25 10:20:10 -0700

**These Next Six Pages (Pages #13 – 18) Comprising Bid Proposal Must Be Completed and Uploaded Into ProcureWare Via The Question Tab and corresponding question #3.**

**BID PROPOSAL**

**PROJECT: # ITB 6184-24**

Quarterly Crane, Hoist, Trolley and Lifeline Preventative Maintenance Inspections and Services – Prevailing Wages

**BIDDER'S DECLARATION.**

The undersigned bidder certifies that it has examined the site, read and understands the specifications for the above project, and agrees to comply with all applicable federal, state and local laws and regulations. The bidder is advised that by signature of this bid proposal it has acknowledged all bid requirements and signed all certificates contained herein.

**BID OFFER.**

The price(s) listed in this bid proposal is tendered as an offer to furnish all labor, materials, equipment and supervision required to complete the proposed project in strict accordance with the contract documents. The bidder proposes to do the services at the following price:

January 1, 2025 Through December 31, 2025:

<b>SCHEDULED SERVICES</b>			
Annual Total Cost Comprised Of The Four (4) Quarterly Preventative Maintenance Inspections Per Calendar Year <b>"Inclusive of all lubrication-materials required, labor, travel cost"</b>	Cost Per Individual Quarterly Inspection	Qty	Total Annual Cost for 4 Quarterly Inspections
	<b>\$ 12,537.12</b>	4 Quarterly Inspects per year	<b>\$ 50,148.48</b>
		Subtotal	<b>\$ 50,148.48</b>
		Tax 9%	<b>\$ 4,513.36</b>
		Extended Total	<b>\$ 54,661.84</b>
Vendor's Percentage Markup Above Vendor's Cost For Any Parts and Materials Determined To Be Needed As Result Of Inspection, or that is required as a result of Unscheduled-Service request. Vendor would be responsible for installing/replacing under resulting contract at applicable hourly contract rate. <b>Percentage Markup will remain unchanged throughout the five-year contract period.</b> Enter Percentage Markup Above Vendor's Cost Here.			<u>20</u> %
<b>UNSCHEDULED SERVICES</b>			
Unscheduled Non-Emergency	Non-Emergency Repairs. Contractor shall be on site with 24 hours, unless a different response is mutually agreed upon and coordinated between Contractor and WTEF Maintenance Supervisor. On average it is estimated that there are 5 are Non-Emergency Calls per year that could result in an estimated annual total of 50 hours more or less.		

<b>Unscheduled Emergency</b>	Emergency Calls, Contractor shall be on site within 4 hours of notification. On average it is estimated that there are 4 Emergency Calls per year, that could result in an estimated annual total of 45 hours more or less.
<b>Straight Time Hourly Rate</b>	\$178.00
<b>Define Straight Time:</b>	6:00AM - 2:30PM, Monday-Friday
<b>Overtime Hourly Rate</b>	\$235.00
<b>Define Overtime:</b>	2:30PM - 6:00AM, Monday-Thursday
<b>Emergency Work Rate/After Straight Rate</b>	\$235.00
<b>Define Emergency Work Rate:</b>	After 2:30PM Friday - 6:00AM Monday
<b>Holiday Hourly Rate</b>	\$315.00
<b>Define Holiday Rate:</b>	New Year's Day, Memorial Day, Independence Day, Labor Day, Thanksgiving Day, Christmas Eve, Christmas Day
<b>Travel Cost Per "Unscheduled-Service"</b>	\$0.00
<b>Define Travel Cost Per "Unscheduled-Service":</b>	No Travel Charge

**ADDENDA.**

The undersigned acknowledges receipt of addenda number(s) 2 and agrees that their requirements have been included in this bid proposal.

**PERIOD OF PERFORMANCE.**

The bidder agrees the period of performance of any contract resulting from this ITB is tentatively scheduled to begin on or about January 1, 2025, and to end on December 31, 2029.

**LIQUIDATED DAMAGES.**

In the event the bidder is awarded the contract and fails to complete the work within the time limit or any agreed upon time extensions, liquidated damages shall be paid to the City of Spokane in the amount of Ten thousand Dollars (\$10,000.00) per working day until the work is satisfactorily completed.

**BIDDER RESPONSIBILITY.**

Washington State Contractor's Registration No. CC WASHIEM099QK  
(must be in effect at time of bid submittal)

U.B.I. Number 601-174-038

Washington Employment Security Department Number 000-669191-00-5

Washington Excise Tax Registration Number 601-174-038

City of Spokane Business License Number T12002901BUS

(The successful bidder and all subcontractors shall be licensed or have applied for a license to do business in the City of Spokane prior to proceeding with the proposed project.)

**BID SECURITY.**

A bid security in the amount of FIVE PERCENT (5%) of the total project bid as indicated above, is attached to this bid proposal. If the bidder is awarded the contract and fails to enter into a construction contract and/or furnish payment / performance bond(s) and proof of insurance within the required time period, the bid security shall be forfeited to the City of Spokane.

**NON-COLLUSION.**

The undersigned authorized representative of the undersigned firm, being first sworn on oath, certifies that the firm has not, directly or indirectly, entered into any agreement, participated in any collusion, or otherwise taken any action in restraint of free competitive bidding in connection with the project for which this bid proposal is submitted.

Name of Bidder: WEMCO, Inc.

  
\_\_\_\_\_  
*Signature of Bidder's Authorized Representative*

VP  
\_\_\_\_\_  
*Title*

5510 W. Thorpe Rd.  
Spokane, WA 99224  
\_\_\_\_\_  
*Address*

509-244-4773  
\_\_\_\_\_  
*Phone*

**IF INDIVIDUAL**

Signed and Sworn To (or Affirmed) Before Me On \_\_\_\_\_  
*date*

(Seal Or Stamp) \_\_\_\_\_  
*Signature of Notary Public*

My appointment expires \_\_\_\_\_

**IF PARTNERSHIP**

I certify that I know or have satisfactory evidence that the above named person signed this bid proposal, on oath stated that he/she was authorized to sign it and acknowledged it as the partner(s) of the bidder, a partnership, to be the free and voluntary act of such party for the uses and purposes herein mentioned.

Signed and Sworn To (or Affirmed) Before Me On \_\_\_\_\_  
date

(Seal Or Stamp)

\_\_\_\_\_  
Signature of Notary Public

My appointment expires \_\_\_\_\_

**\* IF CORPORATION**

I certify that I know or have satisfactory evidence that the above named person signed this bid proposal, on oath stated that he/she was authorized to sign it and acknowledged it as the representative of the bidder, a corporation, to be the free and voluntary act of such party for the uses and purposes herein mentioned.

Signed and Sworn To (or Affirmed) Before Me On 9/30/2024  
date

(Seal Or Stamp)

  
\_\_\_\_\_  
Signature of Notary Public

My appointment expires 1-19-2028





This Page (Page #20) Must Be Completed and Uploaded Into ProcureWare Via The Question Tab and corresponding question #5.

# SUBCONTRACTOR LIST

City of Spokane Project Name: ITB 6184-24, Quarterly Crane, Hoist, Trolley and Lifeline Preventative Maintenance Inspections and Services – Prevailing Wages.

*This form is to be submitted with the Bid Proposal, or within one (1) hour after the published bid submittal time, unless bidder had submitted it with its bid response.*

**RCW 39.30.060 (as amended) states:** “Every invitation to bid on a prime contract that is expected to cost one million dollars or more for the construction, alteration, or repair of any public building or public work ... shall require each prime contract bidder to submit as part of the bid, or within one (1) hour after the published bid submittal time, the names of the subcontractors with whom the bidder, if awarded the contract, will subcontract for performance of the work of: electrical as described in chapter 19.28 RCW, or to name itself for the work.

**The prime contract bidder shall** not list more than one (1) subcontractor for each category of work identified, unless subcontractors vary with bid alternates, in which case the prime contract bidder must indicate which subcontractor will be used for which alternate. Failure of the prime contract bidder to submit as part of the bid the names of such subcontractors or to name itself to perform such work or the naming of two or more subcontractors to perform the same work shall render the prime contract bidder's bid nonresponsive and, therefore, void.” (emphasis added)

Subcontractor Named (List prime contract bidder if prime contract bidder intends to self-perform the work): \_\_\_\_\_ **NO SUBCONTRACTORS WILL BE USED**

Work to be performed: \_\_\_\_\_

Subcontractor Named: (List prime contract bidder if prime contract bidder intends to self-perform the work) \_\_\_\_\_

Work to be performed: \_\_\_\_\_

Subcontractor Named (List prime contract bidder if prime contract bidder intends to self-perform the work): \_\_\_\_\_

Work to be performed: \_\_\_\_\_

Subcontractor Named (List prime contract bidder if prime contract bidder intends to self-perform the work): \_\_\_\_\_

Work to be performed: \_\_\_\_\_

Subcontractor Named (List prime contract bidder if prime contract bidder intends to self-perform the work): \_\_\_\_\_

Work to be performed: \_\_\_\_\_

This Page (Page #19) Must Be Completed and Uploaded Into ProcureWare Via The Question Tab and corresponding question #4.

BID BOND

We, Washington Equipment Manufacturing Company, Inc. dba WEMCO as Principal, and Merchants Bonding Company (Mutual) as Surety, are held and firmly bound unto the CITY OF SPOKANE, a Washington State municipal corporation, in the penal sum of FIVE PERCENT (5%) OF THE TOTAL AMOUNT BID, for the payment of which we jointly and severally bind ourselves, and our legal representatives and successors.

THE CONDITIONS OF THE OBLIGATION are that if the City of Spokane shall make timely award to the Principal for the

**Quarterly Crane, Hoist, Trolley and Lifeline Preventative Maintenance Inspections and Services – Prevailing Wages**

according to the terms of the bid made by the Principal; and the Principal shall, within the specified time, enter into a contract with the City of Spokane and furnish bond(s) acceptable to the City, if required, then this obligation shall be null and void; otherwise it shall remain in full force and effect; but in no event will the surety's liability exceed this bond's face amount.

SIGNED AND SEALED on September 30, 2024

AS PRINCIPAL

Washington Equipment Manufacturing Company, Inc. dba WEMCO

By:   
Title: \_\_\_\_\_

A valid POWER OF ATTORNEY must accompany this bond.

Merchants Bonding Company (Mutual)  
AS SURETY

By: 

PO Box 14498, Des Moines, IA 50306-3498  
Address

509-747-3121  
Phone

Attorney in Fact , Travis Long

# MERCHANTS BONDING COMPANY™

## POWER OF ATTORNEY

Know All Persons By These Presents, that MERCHANTS BONDING COMPANY (MUTUAL) and MERCHANTS NATIONAL BONDING, INC., both being corporations of the State of Iowa, d/b/a Merchants National Indemnity Company (in California only) (herein collectively called the "Companies") do hereby make, constitute and appoint, individually,

Daniel J Stowe; H Keith McNally; Ryan Pugh; Shelby Groth; Sydney Schmidt; Travis Long; WM Dinneen

their true and lawful Attorney(s)-in-Fact, to sign its name as surety(ies) and to execute, seal and acknowledge any and all bonds, undertakings, contracts and other written instruments in the nature thereof, on behalf of the Companies in their business of guaranteeing the fidelity of persons, guaranteeing the performance of contracts and executing or guaranteeing bonds and undertakings required or permitted in any actions or proceedings allowed by law.

This Power-of-Attorney is granted and is signed and sealed by facsimile under and by authority of the following By-Laws adopted by the Board of Directors of Merchants Bonding Company (Mutual) on April 23, 2011 and amended August 14, 2015 and adopted by the Board of Directors of Merchants National Bonding, Inc., on October 16, 2015.

"The President, Secretary, Treasurer, or any Assistant Treasurer or any Assistant Secretary or any Vice President shall have power and authority to appoint Attorneys-in-Fact, and to authorize them to execute on behalf of the Company, and attach the seal of the Company thereto, bonds and undertakings, recognizances, contracts of indemnity and other writings obligatory in the nature thereof."

"The signature of any authorized officer and the seal of the Company may be affixed by facsimile or electronic transmission to any Power of Attorney or Certification thereof authorizing the execution and delivery of any bond, undertaking, recognizance, or other suretyship obligations of the Company, and such signature and seal when so used shall have the same force and effect as though manually fixed."

In connection with obligations in favor of the Florida Department of Transportation only, it is agreed that the power and authority hereby given to the Attorney-in-Fact includes any and all consents for the release of retained percentages and/or final estimates on engineering and construction contracts required by the State of Florida Department of Transportation. It is fully understood that consenting to the State of Florida Department of Transportation making payment of the final estimate to the Contractor and/or its assignee, shall not relieve this surety company of any of its obligations under its bond.

In connection with obligations in favor of the Kentucky Department of Highways only, it is agreed that the power and authority hereby given to the Attorney-in-Fact cannot be modified or revoked unless prior written personal notice of such intent has been given to the Commissioner-Department of Highways of the Commonwealth of Kentucky at least thirty (30) days prior to the modification or revocation.

In Witness Whereof, the Companies have caused this instrument to be signed and sealed this 25th day of June, 2024.



MERCHANTS BONDING COMPANY (MUTUAL)  
MERCHANTS NATIONAL BONDING, INC.  
d/b/a MERCHANTS NATIONAL INDEMNITY COMPANY

By

*Larry Taylor*  
President

STATE OF IOWA  
COUNTY OF DALLAS ss.

On this 25th day of June, 2024, before me appeared Larry Taylor, to me personally known, who being by me duly sworn did say that he is President of MERCHANTS BONDING COMPANY (MUTUAL) and MERCHANTS NATIONAL BONDING, INC.; and that the seals affixed to the foregoing instrument are the Corporate Seals of the Companies; and that the said instrument was signed and sealed in behalf of the Companies by authority of their respective Boards of Directors.

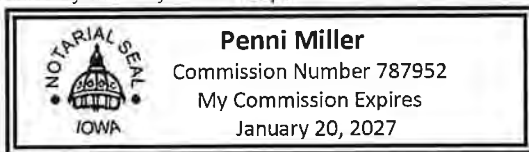

(Expiration of notary's commission does not invalidate this instrument)

*Penni Miller*  
Notary Public

I, William Warner, Jr., Secretary of MERCHANTS BONDING COMPANY (MUTUAL) and MERCHANTS NATIONAL BONDING, INC., do hereby certify that the above and foregoing is a true and correct copy of the POWER-OF-ATTORNEY executed by said Companies, which is still in full force and effect and has not been amended or revoked.

In Witness Whereof, I have hereunto set my hand and affixed the seal of the Companies on this 30th day of September, 2024.



*William Warner Jr.*  
Secretary

Next Six Pages (Pages #23 – 28, plus as needed) Completed and Uploaded Into ProcureWare Via The Question Tab and corresponding question #6, else provide within 24 hours after notification.



## City of Spokane, Washington Supplemental Bidder Responsibility Criteria

Should Bidders not have shall completed, sign and submit this form with attachments with Bid, then after bid opening and prior to award, the apparent low bidder, or those bidder contacted, shall complete, sign and submit this form with attachments to the City (See instructions at the end of this form). The form shall be submitted within twenty four (24) hours after the notification, unless a different time and date is required by the specifications or otherwise mutually agreed upon.	
Project Name: <b>Quarterly Crane, Hoist, Trolley and Lifeline Preventative Maintenance Inspections and Services – Prevailing Wages.</b>	
Project # <b>ITB 6184-24</b>	
<b>Part A: General Company Information</b>	
Company Name	
Address	
Contact Name and Title	
Contact Phone	Contact E-mail
Years in business as a Prime Contractor	Years in business as a sub-contractor
Years in business under present Name	
List any former company names under which the company, its owners, and/or its principals has operated in the past five (5) years	
Explain reason for name change(s) in the past five (5) years	
<b>Part B: Work Experience</b>	
If the request for bids has project specific criteria, including work experience, list at least the requested number of projects (or a minimum of two projects if a requested number was note stated) completed within the required time frame (last five years) on the attached Project Experience form which are similar in type, size and scope of work required for this project	
<b>Part C: Performance Evaluation</b>	
Under past or present names does the bidder have a history of receiving “deficient” or “inadequate” evaluations on two (2) or more contracts from the City or other municipalities or another governmental agency on a public works project within the last five (5) years?	
<input type="checkbox"/> Yes <input type="checkbox"/> No	
If “Yes” attach a separate, signed / dated statement listing the projects and an explanation.	
<b>Part D: Record of Debarment / Disqualification</b>	

Has the bidder (including the primary contractor, any firm with which any of the primary contractor's owners, officers, or partners was associated) been debarred, disqualified, removed or has been otherwise prevented from bidding on, or completing any governmental agency or public works projects, including debarment by the federal, state or other municipal government during the last five (5) years?
<input type="checkbox"/> Yes <input checked="" type="checkbox"/> No
If "Yes", attach a separate signed / dated statement listing any debarments, disqualifications, removal, etc. from any governmental public works project and the basis for the action.
<b>Part E: Safety</b>
In the last five (5) years, has the bidder received willful or repeat violations of safety or health regulations by the OSHA or other agencies responsible for safety oversight? The Contractor shall submit safety records for the past three (3) years including OSHA 300A logs, recordable incidents, lost time accident statistics, EMR rating, OSHA type violations and NAICS code. The Contractor shall submit a list of any work activities previously performed at the City of Spokane WTEF. It is expected the contractor will have an EMR rating <1, OSHA recordable rate below industry average and no OSHA Violations for the past 3 years.
<input type="checkbox"/> Yes <input checked="" type="checkbox"/> No
If "Yes," attach a separate signed /dated statement describing each willful or repeat violation, including information about the dates and nature of the violations, the project on which the citation(s) was or were issued, the amount of penalty paid, if any. If the citation was appealed and a decision has been issued, state the case number and the date of the decision.
<b>Part F: Environmental</b>
In the last five (5) years, has the bidder received serious citations from government environmental enforcement agencies on projects for which the bidder was the contractor?
<input type="checkbox"/> Yes <input checked="" type="checkbox"/> No
If "Yes," attach a separate signed / dated statement describing each serious citation, including information about the dates of the citations, the nature of the violation, the project on which the citation(s) was or were issued, the amount of penalty paid, if any. If the citation was appealed and a decision has been issued, state the case number and the date of the decision.
<b>Part G: Discrimination</b>
Has the bidder or any of its owners, officers or partners been found guilty of violating or failing to comply with discrimination laws in contracting, employment or provision of public services?
<input type="checkbox"/> Yes <input checked="" type="checkbox"/> No
If "Yes", attach a separate signed / dated statement identifying the type of violation, who was involved, the name of the public agency, year of the investigation, the resolution in court or administrative process, and the grounds for the findings.
<b>Part H. Prevailing Wage</b>
In the last five (5) years, has the bidder received prevailing wage violations as determined by the applicable state or federal government agency monitoring prevailing and/or Davis Bacon wage compliance?
<input type="checkbox"/> Yes <input checked="" type="checkbox"/> No

<p>If “Yes,” attach a separate signed/dated statement listing the prevailing wage violations, along with an explanation of each violation and how it was resolved. The City shall evaluation these explanations and the resolution of each violation to determine whether the violations demonstrate a pattern of failure to pay prevailing wages to workers unless there are extenuating circumstances acceptable to the City.</p>
<p><b>Part I. Claims Against Retainage and Bonds</b></p>
<p>Does the bidder have a record of multiple claims filed against the retainage or payment bonds for public works projects during the previous three (3) years?</p>
<p><input type="checkbox"/> Yes      <input checked="" type="checkbox"/> No</p>
<p>If “Yes”, attach a separate signed / dated statement listing the claims filed against the retainage and/or payment bond for any completed public works projects and include for each project a written explanation of the circumstances surrounding the claim and the ultimate resolution of the claim. The City shall evaluate the statement to determine if it demonstrates a lack of effective management by the bidder of making timely and appropriate payments, unless there are extenuating circumstances acceptable to the City in its sole discretion.</p>
<p><b>Part J. Termination for Cause</b></p>
<p>Has the bidder had any public works contract terminated for cause by any government agency during the previous five (5) years?</p>
<p><input type="checkbox"/> Yes      <input checked="" type="checkbox"/> No</p>
<p>If “Yes”, attach a separate signed / dated statement listing each contract terminated, the government agency terminating the contract and the circumstances involving the termination for cause. The City will determine if there are extenuating circumstances acceptable to the City in its sole discretion.</p>
<p><b>Part K: Litigation</b></p>
<p>Has the bidder been involved in lawsuits (or arbitrations for those instances where arbitration is completed in lieu of a lawsuit) with judgments entered against the bidder for failure to meet terms on contracts in the previous five (5) years?</p>
<p><input type="checkbox"/> Yes      <input checked="" type="checkbox"/> No</p>
<p>If “Yes”, attach a list of lawsuits and/or arbitrations with judgments / arbitration awards entered against the bidder along with a written explanation of the circumstances surrounding each lawsuit and/or arbitration. The City will evaluate the explanations to determine whether the lawsuits and/or arbitrations demonstrate a pattern of failing to meeting terms of conditions of contracts, unless there are extenuating circumstances acceptable to the City in its sole discretion.</p>
<p><b>Part L: Delinquent State Taxes</b></p>
<p>Does the bidder owe delinquent taxes to the Washington State Department of Revenue without a payment plan approved by the Department before the date of contract award?</p>
<p><input type="checkbox"/> Yes      <input checked="" type="checkbox"/> No</p>
<p>If “Yes”, attach a separate signed / dated statement describing the circumstances and stating that the bidder is not on the Washington State Department of Revenue’s “Delinquent Taxpayer List”.</p>
<p><b>Part M: Subcontractor Responsibility</b></p>
<p>Does the bidder’s standard subcontract form include the subcontractor language required by RCW 39.06.020? Does the bidder have an established procedure which it uses to validate the responsibility of each of its subcontractor? Does the subcontract form require that each of the bidder’s subcontractors have and document a similar procedure for sub-tier subcontractors?</p>

<input type="checkbox"/> Yes <input checked="" type="checkbox"/> No	
If "Yes" or "No", provide a copy of its standard subcontract form and a copy of the procedures used to validate the responsibility of subcontractors.	
<b>Signature</b>	
The undersigned certifies that the information and data contained herein is correct and complete. Failure to disclose information or submitting false or misleading information may result in rejection of my bid, revocation of award, contract termination, or may impact my firm's ability to bid on future projects by the City of Spokane.	
Signature of Authorized Representative	Date
	9/30/2024
Printed Name of Authorized Representative	Title
Matthew L Humphrey	Part Sales & Service Coordinator

## Attachment to Supplemental Bidder Responsibility Criteria

### Work Experience Form

Please complete one form per project and include the minimum number of projects (and forms) as requested. You may include any additional work experience you deem relevant in determining bidder responsibility. Please be sure to provide a thorough description of the work in order to demonstrate how your firm meets any required experience detailed in the specifications. You may attach additional documentation if needed.			
<b>PROJECT DETAIL</b>			
Bidder's Company Name  WEMCO, Inc.		Bidders Contact Name & Phone Number  Matt Humphrey, 509-244-4773	
Project Name Quarterly Crane/Hoist/Trolley and Lifeline Preventative Maintenance Inspections and Unscheduled Services		Project Contract Number OPR 2019-0959	
Project Owner City of Spokane		Project Location City of Spokane - WTEF	
Project Owner Contact Name & Title David Paine		Owner's Telephone Number (509)625-6878	
Notice to Proceed Date Current 5th Year Contract - 1/1/2024	Final Completion Date Current 5th Year Contract - 12/31/2024	Awarded Contract Value \$60,000.00	Final Contract Price \$60,000.00
Prime Contractor Name (If Not Bidder)  N/A		Contractor Contact Name & Phone Number (If Not Bidder)  N/A	
Brief Project Description  Quarterly Crane/Hoist/Trolley and Lifeline Preventative Maintenance Inspections and Unscheduled Services			
Brief Summary Of Technical Work Completed By Bidder, Including Any Relevant Details To Demonstrate Similar Experience And Any Required Experience Detailed In the Specifications Performed Quarterly Inspections and As Needed Repairs to Cranes, Hoists and Lifelines at WTEF for the City of Spokane the past 4.75 years. We continuously strive to provide thorough inspections of equipment for our clients to keep their employees safe and downtime to a minimum.			



## Instructions for the Supplemental Bidder Responsibility Form

<p>After bid opening and prior to award, the apparent low bidder shall complete, sign and submit this form with attached documentation to the City of Spokane Purchasing Section by one of the methods listed below within twenty four (24) hours of notification.</p>
<p>The City’s evaluation may include further investigations to establish the responsibility, qualifications, financial resources and experience of a bidder to complete the work of this contract. The City may contact previous owners or others to validate the information provided by the bidder. The City will assess the information provided and other information gathered in determining whether a bidder is responsible. List all information you feel is relevant to the City making an informed decision. The City reserves the right to request additional information from the bidder.</p>
<p>For criteria with check boxes, the bidder will check either “Yes” or “No. ” For each “Yes” answer on the form, the Bidder shall provide a signed and dated statement providing the project information requested and explaining the extenuating circumstances.</p>
<p><b>Form Submittal:</b></p>
<p>Submit this form to Purchasing Department by one of the following methods within twenty four (24) hours after the time of notification (unless the specifications provide a different time or date)</p>
<p>Emails (preferable)      <a href="mailto:RRinderle@spokanecity.org">RRinderle@spokanecity.org</a></p>
<p style="text-align: center;">with the Email Subject line: Supplemental Bidder Form for City of Spokane Quarterly Crane, Hoist, Trolley and Lifeline Preventative Maintenance Inspections and Services – Prevailing Wages.</p>
<p>Questions: Please call (509) 625-6527</p>

# Summary of Work-Related Injuries and Illnesses

Year 20 21

All establishments covered by Part 1904 must complete this Summary page, even if no work-related injuries or illnesses occurred during the year. Remember to review the Log to verify that the entries are complete and accurate before completing this summary.

Using the Log, count the individual entries you made for each category. Then write the totals below, making sure you've added the entries from every page of the Log. If you had no cases, write "0."

Employers, former employees, and their representatives have the right to review the OSHA Form 300 in its entirety. They also have limited access to the OSHA Form 301 or its equivalent. See 29 CFR Part 1904.35, in OSHA's recordkeeping rule, for further details on the access provisions for these forms.

### Number of Cases

Total number of deaths	Total number of cases with days away from work	Total number of cases with job transfer or restriction	Total number of other recordable cases
0 (G)	0 (H)	0 (I)	3 (J)

### Number of Days

Total number of days away from work	Total number of days of job transfer or restriction
0 (K)	0 (L)

### Injury and Illness Types

Total number of... (M)	(4) Poisonings	0
(1) Injuries	(5) Hearing loss	0
(2) Skin disorders	(6) All other illnesses	0
(3) Respiratory conditions		

Post this Summary page from February 1 to April 30 of the year following the year covered by the form.

Public reporting burden for this collection of information is estimated to average 58 minutes per response, including time to review the instructions, search and gather the data needed, and complete and review the collection of information. Persons are not required to respond to the collection of information unless it displays a currently valid OMB control number. If you have any comments about these estimates or any other aspects of this data collection, contact: US Department of Labor, OSHA Office of Statistical Analysis, Room N-3644, 200 Constitution Avenue, NW, Washington, DC 20210. Do not send the completed forms to this office.

### Establishment information

Your establishment name WEMCO, INC.  
 Street 5610 W. Thorpe Rd.  
 City Spokane State WA ZIP 99224

Industry description (e.g., *Manufacture of motor truck trailers*)  
MANUFACTURING  
 Standard Industrial Classification (SIC), if known (e.g., 3715)  
 \_\_\_\_\_

OR  
 North American Industrial Classification (NAICS), if known (e.g., 336212)  
333517

### Employment information

(If you don't have these figures, see the Worksheet on the back of this page to estimate.)

Annual average number of employees 85  
 Total hours worked by all employees last year 171,95

**Sign here**  
**Knowingly falsifying this document may result in a fine.**

I certify that I have examined this document and that to the best of my knowledge the entries are true, accurate, and complete.

Karna K Roker President  
 Company executive Title  
509 244-4773 01/25/2022  
 Phone Date

# Summary of Work-Related Injuries and Illnesses

Year 2022

U.S. Department of Labor  
Occupational Safety and Health Administration

Form approved OMB no. 1218-0176

All establishments covered by Part 1904 must complete this Summary page, even if no work-related injuries or illnesses occurred during the year. Remember to review the Log to verify that the entries are complete and accurate before completing this summary.

Using the Log, count the individual entries you made for each category. Then write the totals below, making sure you've added the entries from every page of the Log. If you had no cases, write "0."

Employees, former employees, and their representatives have the right to review the OSHA Form 300 in its entirety. They also have limited access to the OSHA Form 301 or its equivalent. See 29 CFR Part 1904.35, in OSHA's recordkeeping rule, for further details on the access provisions for these forms.

### Number of Cases

Total number of deaths	0	(G)	Total number of cases with job transfer or restriction	3	(I)	Total number of other recordable cases	2	(J)
------------------------	---	-----	--	---	-----	--	---	-----

### Number of Days

Total number of days away from work	0	(K)	Total number of days of job transfer or restriction	183	(L)
-------------------------------------	---	-----	---	-----	-----

### Injury and Illness Types

(1) Injuries	5	(4) Poisonings	0
(2) Skin disorders	0	(5) Hearing loss	0
(3) Respiratory conditions	0	(6) All other illnesses	0

**Post this Summary page from February 1 to April 30 of the year following the year covered by the form.**

Public reporting burden for this collection of information is estimated to average 50 minutes per response, including time to review the instructions, search and gather the data needed, and complete and review the collection of information. Persons are not required to respond to the collection of information unless it displays a currently valid OMB control number. If you have any comments about these estimates or any other aspects of this data collection, contact: US Department of Labor, OSHA Office of Statistical Analysis, Room N-3664, 200 Constitution Avenue, NW, Washington, DC 20210. Do not send the completed forms to this office.

### Establishment information

Your establishment name WEMCO

Street 5510 W. Thorpe Rd.

City Spokane State WA ZIP 99224

Industry description (e.g., *Manufacture of motor truck trailers*)

MANUFACTURING

Standard Industrial Classification (SIC), if known (e.g., 3715)

OR

North American Industrial Classification (NAICS), if known (e.g., 336212)

333517

**Employment information** (If you don't have these figures, see the Worksheet on the back of this page to estimate.)

Annual average number of employees 85

Total hours worked by all employees last year 170,234

### Sign here

Knowingly falsifying this document may result in a fine.

I certify that I have examined this document and that to the best of my knowledge the entries are true, accurate, and complete.

Company executive President  
 The 18, 2023  
 Date  
 Phone (509) 244-4713



# Summary of Work-Related Injuries and Illnesses

Year 20 23



All establishments covered by Part 1904 must complete this Summary page, even if no work-related injuries or illnesses occurred during the year. Remember to review the Log to verify that the entries are complete and accurate before completing this summary.

Using the Log, count the individual entries you made for each category. Then write the totals below, making sure you've added the entries from every page of the Log. If you had no cases, write "0."

Employees, former employees, and their representatives have the right to review the OSHA Form 300 in its entirety. They also have limited access to the OSHA Form 301 or its equivalent. See 29 CFR Part 1904.35, in OSHA's recordkeeping rule, for further details on the access provisions for these forms.

### Number of Cases

Total number of deaths	0	(G)	Total number of cases with days away from work	1	(H)	Total number of cases with job transfer or restriction	1	(I)	Total number of other recordable cases	4	(J)
------------------------	---	-----	--	---	-----	--	---	-----	--	---	-----

### Number of Days

Total number of days away from work	2	(K)	Total number of days of job transfer or restriction	9	(L)
-------------------------------------	---	-----	---	---	-----

### Injury and Illness Types

Total number of ...	(M)	(4) Poisonings	0
(1) Injuries	0	(5) Hearing loss	0
(2) Skin disorders	0	(6) All other illnesses	0
(3) Respiratory conditions	0		

Post this Summary page from February 1 to April 30 of the year following the year covered by the form.

Public reporting burden for this collection of information is estimated to average 50 minutes per response, including time to review the instructions, search and gather the data needed, and complete and review the collection of information. Persons are not required to respond to the collection of information unless it displays a currently valid OMB control number. If you have any comments about these estimates or any other aspects of this data collection, contact: US Department of Labor, OSHA Office of Statistical Analysis, Room N-3644, 200 Constitution Avenue, NW, Washington, DC 20210. Do not send the completed forms to this office.

### Establishment information

Your establishment name WEMCO  
 Street 5510 W. Thorpe Rd.  
 City Spokane State WA ZIP 99224

Industry description (e.g., Manufacture of motor truck trailers)  
 Standard Industrial Classification (SIC), if known (e.g., 3715) \_\_\_\_\_  
 OR \_\_\_\_\_  
 North American Industrial Classification (NAICS), if known (e.g., 336212) 333517

### Employment information (If you don't have these figures, see the Worksheet on the back of this page to estimate.)

Annual average number of employees 85  
 Total hours worked by all employees last year 108,413

### Sign here

Knowingly falsifying this document may result in a fine.

I certify that I have examined this document and that to the best of my knowledge the entries are true, accurate, and complete.

Kamak Rowe Title President  
 Company executive  
 Phone 509 244-4113 Date 1/18/24



# Log of Work-Related Injuries and Illnesses

**Attention:** This form contains information relating to employee health and must be used in a manner that protects the confidentiality of employees to the extent possible while the information is being used for occupational safety and health purposes.

Year 2022\_3

Form approved OMB no. 1218-0176

You must record information about every work-related death and about every work-related injury or illness that involves loss of consciousness, restricted work activity or job transfer, days away from work, or medical treatment beyond first aid. You must also record significant work-related injuries and illnesses that are diagnosed by a physician or licensed health care professional. You must also record work-related injuries and illnesses that meet any of the specific recording criteria listed in 29 CFR Part 1904.8 through 1904.12. Feel free to use two lines for a single case if you need to. You must complete an injury and illness incident Report (OSHA Form 301) or equivalent form for each injury or illness recorded on this form. If you're not sure whether a case is recordable, call your local OSHA office for help.

Establishment name WEMCO  
City Spokane State WA

Identify the person			Describe the case			Classify the case					Enter the number of days the injured or ill worker was:		Check the "Injury" column or choose one type of illness:								
(A) Case no.	(B) Employee's name	(C) Job title (e.g., Welder)	(D) Date of injury or onset of illness	(E) Where the event occurred (e.g., Loading dock north end)	(F) Describe injury or illness, parts of body affected, and object/substance that directly injured or made person ill (e.g., Second degree burns on right forearm, from acetylene torch)	Death (G)	Days away from work (H)	Job transfer or restriction (I)	Other recordable cases (J)	Away from work (K) days	On job transfer or restriction (L) days	Injury (1)	Skin disorder (2)	Respiratory condition (3)	Poisoning (4)	Hearing loss (5)	All other illnesses (6)				
1	John Spicer	Welder	4/11 month/day	Fab	debris in eye					0	0										
2	Tyler Shields	PM	5/9 month/day	I-90	Neck strain					2	0										
3	John Sanburn	Engineer	5/9 month/day	I-90	Neck strain					0	0										
4	Russell Kolar	Engineer	5/9 month/day	I-90	Neck strain, calf crushed					0	0										
5	John Spicer	Welder	8/10 month/day	Fab	debris in eye					0	9										
6	Nick Handley	welder	12/21 month/day	Fab	foot smooashed																
			month/day																		
			month/day																		
			month/day																		
			month/day																		
			month/day																		
			month/day																		
			month/day																		
<b>Page totals</b>																					
2																					
1																					
1																					
9																					
4																					

**Page 1 of 1**

Be sure to transfer these totals to the Summary page (Form 300A) before you post it.

Public reporting burden for this collection of information is estimated to average 14 minutes per response, including time to review the instructions, search and gather the data needed, and complete and review the collection of information. Persons are not required to respond to the collection of information unless it displays a currently valid OMB control number. If you have any comments about these estimates or any other aspect of this data collection, contact: US Department of Labor, OSHA Office of Statistical Analysis, Room N-3664, 200 Constitution Avenue, NW, Washington, DC 20210. Do not send the completed forms to this office.

235000992166700771110111

State of Washington  
 Department of Labor and Industries  
 PO Box 44140  
 Olympia WA 98504-4140

**THIS IS  
 NOT A  
 BILL**

12-08-23

DEC 13 2023

**Policyholder**  
**WEMCO INC**  
**5510 W THORPE RD**  
**SPOKANE WA 99224**

<b>Rate Notice: WA Workers' Compensation</b>	
Effective Date:	Experience Factor <sup>4</sup> :
<b>January 1, 2024</b>	<b>0.6000</b>
Experience Period:	
<b>July 1, 2019 - June 30, 2022</b>	
WA Unified Business Identifier (UBI):	
<b>601 174 038</b>	
L&I Account ID:	PAC Number:
<b>560,436-00</b>	<b>32179186</b>
Account Manager:	
<b>JAVIER PAREDES</b>	
<b>(360)902-6266</b>	

**What went into calculating your 2024 workers' comp rates?**

- 1. Change in L&I average 'base' rate:** 4.9% average rate increase for 2024; rates specific to your industry can be found on our website at [lni.wa.gov](http://lni.wa.gov)
- 2. Changes in industry costs:** Changes in claim costs compared to premiums collected for your industry ('risk class') in which some or all of your employees worked.
- 3. Your Experience Factor:** Based on the medical, wage replacement and disability benefit costs for worker claims on your account, during the experience period listed above.
- 4. A claim-free discount:** You earned a 40% claim-free discount in your Experience Factor. Learn how to keep the discount at [www.Lni.wa.gov/ClaimFreeDiscount](http://www.Lni.wa.gov/ClaimFreeDiscount).

Pay your premiums online: [www.Lni.wa.gov/QuarterlyReports](http://www.Lni.wa.gov/QuarterlyReports)

Need help understanding this notice? Call your account manager at the phone number shown above.

**Have a payroll service?**  
 Send them a copy of this notice.

Your Rate Information	Class Code	Class Code Description	Accident Fund (AF) <sup>1</sup>	Medical Aid Fund (MA) <sup>2</sup>	Stay at Work Program <sup>3</sup>	Supp. Pension Fund (SP) <sup>5</sup>	Hourly* Employer Contribution	Hourly* Employee Withholding	= Your Total Hourly* Rate [(1+2+3)x4]+5
		4904-00	Clerical Office NOC & Draftsmn	0.0183	0.0112	0.0003	0.1710	\$0.09995	\$0.08895
	5109-46	Hvy Mach & Equip Mfg or Rpr	0.7108	0.3022	0.0108	0.1710	\$0.60590	\$0.17940	\$0.7853
	6303-00	Sales Personnel NOC-Outside	0.0698	0.0342	0.0011	0.1710	\$0.13800	\$0.09610	\$0.2341
	7101-00	Corp Officer NOC (admin only)	0.0416	0.0160	0.0006	0.1710	\$0.11540	\$0.09050	\$0.2059

**Your experience factor history:**

This is the employer's contribution to workers' comp coverage.

Withhold this amount from employee pay for each hour\* they work. It is their contribution to workers' comp coverage.

On the Quarterly Report, the employer will multiply this number by the hours\* worked to calculate premiums.

**What's an experience factor?**  
 See back for an explanation.

**OSHA LOG SUMMARY AND INJURY RATES**

<b>YEAR</b>	<b>2024</b>	<b>2023</b>	<b>2022</b>	<b>2021</b>	<b>2020</b>	<b>2019</b>	<b>2018</b>	<b>2017</b>	<b>2016</b>	<b>2015</b>	<b>2014</b>
<b>TOTAL RECORDABLE INJURIES</b>	0	6	5	3	5	8	3	3	9	7	5
<b>TIME LOSS DAYS</b>	0	2	0	0	0	5	0	0	3	0	0
<b>JOB TRANSFER DAYS</b>	0	9	125	0	113	125	0	43	411	0	?
<b>EMR</b>	.60	.66	.88	1.17	.93	.75	.60	.60	.60	.62	.67
<b>TOTAL RECORDABLE INJURY RATE (TRIR)</b>	0	7.11	5.87	3.48	6.31	12.49	7.04	6.77	15.07	14.53	15.48
<b>AVG # OF EMPLOYEES</b>	85	85	85	85	76	61	41	43	54	48	36
<b>TOTAL HOURS WORKED</b>	TBD	168,613	170,234	171,951	158,234	128,065	85,179	88,605	119,438	96,312	64,578
<b>CASES WITH DAYS AWAY OR RESTRICTIONS</b>	0	2	3	0	3	3	0	1			
<b>DART RATE</b>	0	2.37	3.5	0	3.79	4.68	0	2.25			

TRIR = # OF INJURIES x 200,000 ÷ HOURS WORKED

DART = # OF INJURIES WITH DAYS AWAY OR RESTRICTIONS x 200,000 ÷ HOURS WORKED





JOIN FORCES. SUCCEED TOGETHER.

**HEREBY GRANTS  
WOMAN OWNED SMALL BUSINESS (WOSB) CERTIFICATION TO**

**Washington Equipment Manufacturing Company, Inc. DBA WEMCO INC.**

The identified small business is an eligible WOSB for the WOSB Program, as set forth in 13 C.F.R. part 127 and has been certified as such by an SBA approved Third Party Certifier pursuant to the Third Party Agreement, dated June 30, 2011, and available at [www.sba.gov/wosb](http://www.sba.gov/wosb).

The WOSB Certification expires on the date herein unless there is a change to the SBA's regulation that makes the WOSB ineligible or there is a change in the WOSB that makes the WOSB ineligible. If either occurs, this WOSB Certification is immediately invalid. The WOSB must not misrepresent its certification status to any other party, including any local or State government or contracting official or the Federal government or any of its contracting officials.

Majority Female Owner: Karma Rouse
NAICS: 333923, 236210, 237990, 238290, 332312, 332721, 332999, 333111, 333120, 333132, 333517, 333922, 336413, 811310 UNSPSC: 21101700, 21101703, 23242401, 23290000, 24101602, 24101619, 24101652, 24101653, 24101654, 31391500, 73161516
Certification Number: WOSB210143
Renewal Date: January 31, 2025
WOSB Regulation Expiration Date: 1/31/2027



Janice Greene, PhD, Women's Business Enterprise Council - Pacific President & CEO

Pamela Prince-Easton, WBENC President & CEO

LaKeshia White, Vice President, Certification



**Agenda Sheet for City Council:**

**Committee:** PIES **Date:** 10/21/2024

**Committee Agenda type:** Consent

**Date Rec'd** 10/22/2024

**Clerk's File #** OPR 2024-0931

**Cross Ref #**

**Project #**

**Council Meeting Date:** 11/04/2024

<b>Submitting Dept</b>	SOLID WASTE DISPOSAL	<b>Bid #</b>	ITB 6185-24
------------------------	----------------------	--------------	-------------

<b>Contact Name/Phone</b>	DAVID PAINE 625-6878	<b>Requisition #</b>	CR 26793
---------------------------	----------------------	----------------------	----------

<b>Contact E-Mail</b>	DPAINE@SPOKANECITY.ORG		
-----------------------	------------------------	--	--

<b>Agenda Item Type</b>	Contract Item		
-------------------------	---------------	--	--

<b>Council Sponsor(s)</b>	BWILKERSON JBINGLE KKLITZKE		
---------------------------	-----------------------------	--	--

<b>Agenda Item Name</b>	4490 CONTRACT FOR BRIDGE CRANE MAINTENANCE/INSPECTIONS		
-------------------------	--	--	--

**Agenda Wording**

Five year contract award to WEMCO, Inc. (Spokane, WA) for bridge crane maintenance and inspections at the Waste to Energy Facility from 1/1/2025-12/31/2029 and a cost not to exceed \$370,000.00 plus tax total.

**Summary (Background)**

In 2017, the Waste to Energy Facility installed two new bridge cranes that are used to feed trash into the furnace. These cranes require preventative maintenance and quarterly inspections to ensure they continue operating safely. On September 30, 2024, bidding closed on ITB 6185-24 for these services and Wemco Inc. was the only respondent. The resulting contract would be for five years. Annual expenditures are anticipated to be no more than \$74,000.00 plus tax.

Lease? NO Grant related? NO Public Works? YES

**Fiscal Impact**

Approved in Current Year Budget?

Total Cost	\$ 370,000.00
------------	---------------

Current Year Cost	\$ 74,000.00
-------------------	--------------

Subsequent Year(s) Cost	\$ 74,000.00
-------------------------	--------------

**Narrative**

This is a routine repair and maintenance expense that was planned for in the Solid Waste Disposal budget. All funds are not typically utilized on this type of contract but need to be in place to avoid emergency spending in the event of equipment failures.

**Amount**

**Budget Account**

Expense	\$ 370,000.00	# 4490-44100-37148-54803-34002
---------	---------------	--------------------------------

Select	\$	#
--------	----	---

Select	\$	#
--------	----	---

Select	\$	#
--------	----	---

	\$	#
--	----	---

	\$	#
--	----	---



**Continuation of Wording, Summary, Approvals, and Distribution**

**Agenda Wording**

**Summary (Background)**

**Approvals**

<b><u>Dept Head</u></b>	AVERYT, CHRIS
<b><u>Division Director</u></b>	FEIST, MARLENE
<b><u>Accounting Manager</u></b>	ALBIN-MOORE, ANGELA
<b><u>Legal</u></b>	SCHOEDEL, ELIZABETH
<b><u>For the Mayor</u></b>	PICCOLO, MIKE

**Additional Approvals**

<b><u>PURCHASING</u></b>	PRINCE, THEA

**Distribution List**

Matt Turner, mturner@wemcoinc.com	mdorgan@spokanecity.org
jsalstrom@spokanecity.org	tprince@spokanecity.org
rrinderle@spokanecity.org	mhumphrey@wemcoinc.com

## Committee Agenda Sheet

### Public Infrastructure, Environment & Sustainability Committee

<b>Committee Date</b>	October 21, 2024
<b>Submitting Department</b>	Solid Waste Disposal
<b>Contact Name</b>	David Paine
<b>Contact Email &amp; Phone</b>	<a href="mailto:dpaine@spokanecity.org">dpaine@spokanecity.org</a> , 509-625-6878
<b>Council Sponsor(s)</b>	Wilkerson, Bingle, Klitzke
<b>Select Agenda Item Type</b>	<input checked="" type="checkbox"/> Consent <input type="checkbox"/> Discussion    Time Requested:
<b>Agenda Item Name</b>	Contract for preventative maintenance and inspections of the bridge cranes at the Waste to Energy Facility.
<b>Proposed Council Action</b>	<input checked="" type="checkbox"/> Approval to proceed to Legislative Agenda <input type="checkbox"/> Information Only
<b>Summary (Background)</b>  *use the Fiscal Impact box below for relevant financial information	<p>In 2017, the Waste to Energy Facility installed two new 9-ton, top-running, double-girder bridge cranes. These cranes are used for continuously loading refuse into the furnace for incineration. Even though the cranes are fairly new, they still require preventative maintenance and quarterly inspections to ensure they continue operating safely.</p> <p>On September 30, 2024 bidding closed on ITB 6185-24 for these services and WEMCO, Inc., of Spokane, WA was the only response received. The contract award would be for five (5) years and run from January 1, 2024 through December 31, 2029. The estimated cost for the five year term is \$370,000.00 plus tax.</p>
<p><b>Fiscal Impact</b></p> <p><b>Approved in current year budget?</b>    <input checked="" type="checkbox"/> Yes    <input type="checkbox"/> No    <input type="checkbox"/> N/A</p> <p>Total Cost: <u>\$370,000.00</u></p> <p>    Current year cost: \$74,000.00</p> <p>    Subsequent year(s) cost: \$74,000.00</p> <p><b>Narrative:</b> <u>This is a routine repair and maintenance expense that was planned for in the Solid Waste Disposal budget.</u></p> <p><b>Funding Source</b>            <input type="checkbox"/> One-time    <input checked="" type="checkbox"/> Recurring    <input type="checkbox"/> N/A</p> <p>Specify funding source: Program revenue</p> <p>Is this funding source sustainable for future years, months, etc? Yes</p> <p><b>Expense Occurrence</b>    <input type="checkbox"/> One-time    <input checked="" type="checkbox"/> Recurring    <input type="checkbox"/> N/A</p> <p>Other budget impacts: (revenue generating, match requirements, etc.)</p>	
<p><b>Operations Impacts</b> (If N/A, please give a brief description as to why)</p> <ul style="list-style-type: none"> <li>• What impacts would the proposal have on historically excluded communities? Public works services and projects are designed to serve all citizens and businesses. We strive to offer a consistent level of service to all, to distribute public investment throughout the community and to respond to gaps in services identified in various City plans.</li> </ul>	

- How will data be collected, analyzed, and reported concerning the effect of the program/policy by racial, ethnic, gender identity, national origin, income level, disability, sexual orientation, or other existing disparities?  
N/A
- How will data be collected regarding the effectiveness of this program, policy, or product to ensure it is the right solution?  
Public Works follows the City's established procurement and public works bidding regulations and policies to bring items forward, and then uses contract management best practices to ensure desired outcomes and regulatory compliance.
- Describe how this proposal aligns with current City Policies, including the Comprehensive Plan, Sustainability Action Plan, Capital Improvement Program, Neighborhood Master Plans, Council Resolutions, and others?  
This work is consistent with annual budget strategies to limit costs and approved projects in the 6-year CIP.

**Council Subcommittee Review**

- Please provide a summary of council subcommittee review. If not reviewed by a council subcommittee, please explain why not.

Not applicable



**City of Spokane**  
**PREVENTATIVE MAINTENANCE AGREEMENT**  
  
**Title: Refuse Bridge Cranes Quarterly  
Maintenance Inspections and Services**

This Agreement is made and entered into by and between the **CITY OF SPOKANE** as (“City”), a Washington municipal corporation, and **WEMCO, INC.**, whose address is 5510 West Thorpe Road, Spokane, Washington 99224 as (“Contractor”), individually hereafter referenced as a “Party”, and together as the “Parties”.

*WHEREAS, the purpose of this Agreement is to provide Quarterly Inspections and as needed Services for Refuse Bridge Cranes; and*

*WHEREAS, the Contractor was selected from ITB 6185-24.*

*NOW, THEREFORE, in consideration of the terms, conditions, covenants and performance of the Scope of Work contained herein, the City and Contractor mutually agree as follows:*

**1. TERM OF AGREEMENT.**

The term of this Agreement begins on January 1, 2025, and ends on December 31, 2029, unless amended by written agreement or terminated earlier under the provisions.

**2. TIME OF BEGINNING AND COMPLETION.**

The Contractor shall begin the work outlined in the “Scope of Work” (“Work”) on the beginning date, above. The City will acknowledge in writing when the Work is complete. Time limits established under this Agreement shall not be extended because of delays for which the Contractor is responsible, but may be extended by the City, in writing, for the City’s convenience or conditions beyond the Contractor’s control.

**3. SCOPE OF WORK.**

The Contractor’s General Scope of Work for this Agreement is described in the City’s ITB 6185-24 and Contractor’s Response which is attached as **Attachment C** and made a part of this Agreement. In the event of a conflict or discrepancy in the Agreement documents, this City Agreement controls.

The Work is subject to City review and approval. The Contractor shall confer with the City periodically and prepare and present information and materials (e.g. detailed outline of completed Work) requested by the City to determine the adequacy of the Work or Contractor’s progress.

**4. COMPENSATION / PAYMENT.**

Total compensation for Contractor’s services under this Agreement shall be a maximum amount not to exceed **THREE HUNDRED SEVENTY THOUSAND AND NO/100 DOLLARS (\$370,000.00)**, plus applicable taxes, unless modified by a written amendment to this Agreement. This is the maximum amount to be paid under this Agreement for the work described in Section 3 above and

shall not be exceeded without the prior written authorization of the City in the form of an executed amendment to this Agreement.

The Contractor shall submit its applications for payment to Spokane Solid Waste Disposal, 2900 South Geiger Blvd., Spokane, Washington 99224. All invoices should include the City Clerk's File No. "OPR #2024-XXXX" and an approved L & I Intent to Pay Prevailing Wage number. The final invoice should include an approved Affidavit of Wages Paid number. Payment will not be made without this documentation included on the invoice. **Payment will be made via direct deposit/ACH** within thirty (30) days after receipt of the Company's application except as provided by state law. If the City objects to all or any portion of the invoice, it shall notify the Company and reserves the right to only pay that portion of the invoice not in dispute. In that event, the parties shall immediately make every effort to settle the disputed amount.

**5. LIQUIDATED DAMAGES.** Liquidated damages shall be in accordance with the contract documents.

**6. TAXES, FEES AND LICENSES.**

- A. Contractor shall pay and maintain in current status, all necessary licenses, fees, assessments, permit charges, etc. necessary to conduct the work included under this Agreement. It is the Contractor's sole responsibility to monitor and determine changes or the enactment of any subsequent requirements for said fees, assessments, or changes and to immediately comply.
- B. The cost of any permits, licenses, fees, etc. arising as a result of the projects included in this Agreement shall be included in the project budgets.

**7. PREVENTATIVE MAINTENANCE.**

The following Preventative Maintenance requirements apply to the Work under this Agreement:

- A. The Contractor shall pay state prevailing wages. The Contractor and all subcontractors will submit a "Statement of Intent to Pay Prevailing Wages," certified by the industrial statistician of the Department of Labor and Industries, prior to any payments. The "Statement of Intent to Pay Prevailing Wages" shall include: (1) the Contractor's registration number; and (2) the prevailing wages under RCW 39.12.020 and the number of workers in each classification. Each voucher claim submitted by a Contractor for payment on a project estimate shall state that the prevailing wages have been paid in accordance with the pre-filed statement or statements of intent to pay prevailing wages on file with the City. At the end of the work, the Contractor and subcontractors must submit an "Affidavit of Wages Paid," certified by the industrial statistician.
- B. **STATEMENT OF INTENT TO PAY PREVAILING WAGES TO BE POSTED.** For contracts in excess of \$10,000, the Contractor and each subcontractor required to pay the prevailing rate of wages shall post in a location readily visible at the job site: (1) a copy of a "Statement of Intent to Pay Prevailing Wages" approved by the industrial statistician of the Washington State Department of Labor and Industries (L & I); and (2) the address and telephone number of the industrial statistician of the Department of Labor and Industries where a complaint or inquiry concerning prevailing wages may be made.
- C. A payment/performance bond is NOT required.
- D. Statutory retainage is NOT required.

**8. CITY OF SPOKANE BUSINESS LICENSE.**

Section 8.01.070 of the Spokane Municipal Code states that no person may engage in business with the City without first having obtained a valid annual business registration. The Contractor shall be responsible for contacting the State of Washington Business License Services at [www.dor.wa.gov](http://www.dor.wa.gov) or 360-705-6741 to obtain a business registration. If the Contractor does not believe it is required to obtain a business registration, it may contact the City's Taxes and Licenses Division at (509) 625-6070 to request an exemption status determination.

**9. SOCIAL EQUITY REQUIREMENTS / NON-DISCRIMINATION.**

No individual shall be excluded from participation in, denied the benefit of, subjected to discrimination under, or denied employment in the administration of or in connection with this Agreement because of age, sex, race, color, religion, creed, marital status, familial status, sexual orientation including gender expression or gender identity, national origin, honorably discharged veteran or military status, the presence of any sensory, mental or physical disability, or use of a service animal by a person with disabilities. The Contractor agrees to comply with, and to require that all subcontractors comply with, federal, state and local nondiscrimination laws, including but not limited to: the Civil Rights Act of 1964, the Rehabilitation Act of 1973, the Age Discrimination in Employment Act, and the American's With Disabilities Act, to the extent those laws are applicable.

**10. INDEMNIFICATION.**

The Contractor shall defend, indemnify, and hold the City and its officers and employees harmless from all claims, demands, or suits at law or equity—asserted by third parties for bodily injury (including death) and/or property damage which arise from the Contractor's negligence or willful misconduct under this Agreement, including attorneys' fees and litigation costs; provided that nothing herein shall require a Contractor to indemnify the City against and hold harmless the City from claims, demands or suits based solely upon the negligence of the City, its agents, officers, and employees. If a claim or suit is caused by or results from the concurrent negligence of the Contractor's agents or employees and the City, its agents, officers and employees, this indemnity provision shall be valid and enforceable to the extent of the negligence of the Contractor, its agents or employees. The Contractor specifically assumes liability and agrees to defend, indemnify, and hold the City harmless for actions brought by the Contractor's own employees against the City and, solely for the purpose of this indemnification and defense, the Contractor specifically waives any immunity under the Washington State industrial insurance law, or Title 51 RCW. The Consultant/Contractor/Company recognizes that this waiver was specifically entered into pursuant to the provisions of RCW 4.24.115 and was the subject of mutual negotiation. The indemnity and agreement to defend and hold the City harmless provided for in this section shall survive any termination or expiration of this agreement.

**10. INSURANCE.**

During the period of the Contract, the Contractor shall maintain in force at its own expense, each insurance noted below with companies or through sources approved by the State Insurance Commissioner pursuant to Title 48 RCW:

A. **Worker's Compensation Insurance** in compliance with RCW 51.12.020, which requires subject employers to provide workers' compensation coverage for all their subject workers and Employer's Liability Insurance in the amount of \$1,000,000;

B. **General Liability Insurance** on an occurrence basis, with a combined single limit of not less than \$1,000,000 each occurrence for bodily injury and property damage. It shall include contractual liability coverage for the indemnity provided under this Contract. It shall provide that



the City, its officers and employees are additional insureds but only with respect to the Contractor's services to be provided under this Contract;

i. Acceptable supplementary Umbrella coverage in combination with Commercial General Liability policy shall be a minimum of \$2M in order to meet the minimum insurance coverages required under this contract; and

C. **Automobile Liability Insurance** with a combined single limit, or the equivalent of not less than \$1,000,000 each accident for bodily injury and property damage, including coverage for owned, hired and non-owned vehicles; and

D. **Property Insurance** if materials and supplies are furnished by the Contractor. The amount of the insurance coverage shall be the value of the materials and supplies of the completed value of improvement. Hazard or XCU (explosion, collapse, underground) insurance should be provided if any hazard exists.

There shall be no cancellation, material change, reduction of limits or intent not to renew the insurance coverage(s) without thirty (30) days written notice from the Consultant or its insurer(s) to the City. As evidence of the insurance coverage(s) required by this Agreement, the Consultant shall furnish acceptable Certificates of Insurance (COI) to the City at the time it returns this signed Agreement. The certificate shall specify the City of Spokane as "Additional Insured" specifically for Consultant's services under this Agreement, as well as all of the parties who are additional insureds, and include applicable policy endorsements, the thirty (30) day cancellation clause, and the deduction or retention level. The Consultant shall be financially responsible for all pertinent deductibles, self-insured retentions, and/or self-insurance.

#### **11. SUBCONTRACTOR RESPONSIBILITY.**

The Contractor must verify responsibility criteria for each first-tier subcontractor, and a subcontractor of any tier that hires other subcontractors must verify responsibility criteria for each of its subcontractors. Verification shall include that each subcontractor, at the time of subcontract execution, meets the responsibility criteria listed in RCW 39.04.350(1) and possesses an electrical contractor license, if required by chapter 19.28 RCW, or an elevator contractor license, if required by chapter 70.87 RCW.

#### **12. INDEPENDENT CONTRACTOR.**

The Contractor is an independent Contractor. This Agreement does not intend the Contractor to act as a City employee. The City has neither direct nor immediate control over the Contractor nor the right to control the manner or means by which the Contractor works. Neither the Contractor nor any Contractor employee shall be an employee of the City. This Agreement prohibits the Contractor to act as an agent or legal representative of the City. The Contractor is not granted express or implied rights or authority to assume or create any obligation or responsibility for or in the name of the City, or to bind the City. The City is not liable for or obligated to pay sick leave, vacation pay, or any other benefit of employment, nor to pay social security or other tax that may arise from employment. The Contractor shall pay all income and other taxes as due.

#### **13. ASSIGNMENT AND SUBCONTRACTING.**

The Contractor shall not assign or subcontract its obligations under this Agreement without the City's written consent, which may be granted or withheld in the City's sole discretion. Any subcontract made by the Contractor shall incorporate by reference this Agreement, except as otherwise provided. The Contractor shall ensure that all subcontractors comply with the obligations and requirements of the subcontract. The City's consent to any assignment or subcontract does not release the Contractor from liability or any obligation within this Agreement, whether before or after City consent, assignment or subcontract.

**14. TERMINATION.**

Either party may terminate this Agreement, with or without cause, by ten (10) days written notice to the other party. In the event of such termination, the City shall pay the Contractor for all work previously authorized and performed prior to the termination date.

**15. STANDARD OF PERFORMANCE.**

The standard of performance applicable to Contractor's services will be the degree of skill and diligence normally employed by professional contractors in the region performing the same or similar Contracting services at the time the work under this Agreement are performed.

**16. ANTI KICK-BACK.**

No officer or employee of the City of Spokane, having the power or duty to perform an official act or action related to this Agreement shall have or acquire any interest in the Agreement, or have solicited, accepted or granted a present or future gift, favor, service or other thing of value from or to any person involved in this Agreement.

**17. CONSTRUAL.**

The Contractor acknowledges receipt of a copy of the Agreement documents and agrees to comply with them. The silence or omission in the Agreement documents concerning any detail required for the proper execution and completion of the work means that only the best general practice is to prevail and that only material and workmanship of the best quality are to be used. This Contract shall be construed neither in favor of nor against either party.

**18. DEBARMENT AND SUSPENSION.**

The Contractor has provided its certification that it is in compliance with and shall not contract with individuals or organizations which are debarred, suspended, or otherwise excluded from or ineligible from participation in Federal Assistance Programs under Executive Order 12549 and "Debarment and Suspension", codified at 29 CFR part 98.

**19. CONTRACTOR'S ACKNOWLEDGEMENT AND WARRANTY.**

The Contractor acknowledges that it has visited the site of the work, has examined it, and is qualified to perform the work required by this Agreement.

The Contractor guarantees and warranties all work, labor and materials under this Agreement for one (1) year following final acceptance. If any unsatisfactory condition or defect develops within that time, the Contractor will immediately place the work in a condition satisfactory to the City and repair all damage caused by the condition or defect. The Contractor will repair or restore to the City's satisfaction, in accordance with the contract documents and at its expense, all property damaged by his performance under this Agreement. This warranty is in addition to any manufacturers' or other warranty in the Agreement documents.

**20. MISCELLANEOUS PROVISIONS.**

- A. **Amendments/Modifications:** The City may modify this Agreement and order changes in the work whenever necessary or advisable. The Contractor will accept modifications when ordered in writing by the City, and the Agreement time and compensation will be adjusted accordingly.
- B. The Contractor, at no expense to the City, shall comply with all laws of the United States and Washington, the Charter and ordinances of the City of Spokane; and rules, regulations, orders and directives of their administrative agencies and officers.
- C. This Agreement shall be construed and interpreted under the laws of Washington. The venue of any action brought shall be in a court of competent jurisdiction, located in Spokane County, Washington.

- D. **Captions:** The titles of sections or subsections are for convenience only and do not define or limit the contents.
- E. **Severability:** If any term or provision is determined by a court of competent jurisdiction to be invalid or unenforceable, the remainder of this Agreement shall not be affected, and each term and provision shall be valid and enforceable to the fullest extent permitted by law.
- F. **Waiver:** No covenant, term or condition or the breach shall be deemed waived, except by written consent of the party against whom the waiver is claimed, and any waiver of the breach of any covenant, term or condition shall not be deemed a waiver of any preceding or succeeding breach of the same or any other covenant, term of condition. Neither the acceptance by the City of any performance by the Contractor after the time the same shall have become due nor payment to the Contractor for any portion of the Work shall constitute a waiver by the City of the breach or default of any covenant, term or condition unless otherwise expressly agreed to by the City in writing.
- G. **Entire Agreement:** This document along with any exhibits and all attachments, and subsequently issued addenda, comprises the entire agreement between the City and the Contractor. If conflict occurs between Agreement documents and applicable laws, codes, ordinances or regulations, the most stringent or legally binding requirement shall govern and be considered a part of this Agreement to afford the City the maximum benefits.
- H. **No personal liability:** No officer, agent or authorized employee of the City shall be personally responsible for any liability arising under this Agreement, whether expressed or implied, nor for any statement or representation made or in any connection with this Agreement.
- I. Under Washington State Law (reference RCW Chapter 42.56, the *Public Records Act* [PRA]) all materials received or created by the City of Spokane are **public records** and are available to the public for viewing via the City Clerk's Records (online) or a valid Public Records Request (PRR).

IN WITNESS WHEREOF, in consideration of the terms, conditions and covenants contained, or attached and incorporated and made a part, the parties have executed this Agreement by having legally-binding representatives affix their signatures below.

**WEMCO, INC.**

**CITY OF SPOKANE**

By \_\_\_\_\_  
Signature Date

By \_\_\_\_\_  
Signature Date

\_\_\_\_\_  
Type or Print Name

\_\_\_\_\_  
Type or Print Name

\_\_\_\_\_  
Title

\_\_\_\_\_  
Title

Attest:

Approved as to form:

---

City Clerk

---

Assistant City Attorney

**Attachments that are part of this Agreement:**

Attachment A – Debarment Certification

Attachment B - Certification of Compliance with Wage Payment Statutes

Attachment C – Contractor’s Response to ITB 6185-24

24-201

**ATTACHMENT A**

**CERTIFICATION REGARDING DEBARMENT, SUSPENSION,  
INELIGIBILITY AND VOLUNTARY EXCLUSION**

1. The undersigned (i.e., signatory for the Subrecipient / Contractor / Consultant) certifies, to the best of its knowledge and belief, that it and its principals:
  - a. Are not presently debarred, suspended, proposed for debarment, declared ineligible, or voluntarily excluded from covered transactions by any federal department or agency;
  - b. Have not within a three-year period preceding this contract been convicted or had a civil judgment rendered against them for commission of fraud or a criminal offense in connection with obtaining, attempting to obtain, or performing a public (federal, state, or local) transaction or contract under a public transaction; violation of federal or state antitrust statutes or commission of embezzlement, theft, forgery, bribery, falsification or destruction of records, making false statements, tax evasion, receiving stolen property, making false claims, or obstruction of justice;
  - c. Are not presently indicted or otherwise criminally or civilly charged by a government entity (federal, state, or local) with commission of any of the offenses enumerated in paragraph (1)(b) of this certification; and,
  - d. Have not within a three-year period preceding this contract had one or more public transactions (federal, state, or local) terminated for cause or default.
  
2. The undersigned agrees by signing this contract that it shall not knowingly enter into any lower tier covered transaction with a person who is debarred, suspended, declared ineligible, or voluntarily excluded from participation in this covered transaction.
  
3. The undersigned further agrees by signing this contract that it will include the following clause, without modification, in all lower tier covered transactions and in all solicitations for lower tier covered transactions:

Certification Regarding Debarment, Suspension, Ineligibility and Voluntary Exclusion – Lower Tier Covered Transactions

1. The lower tier contractor certified, by signing this contract that neither it nor its principals is presently debarred, suspended, proposed for debarment, declared ineligible, or voluntarily excluded from participation in this transaction by any federal department or agency.
  
2. Where the lower tier contractor is unable to certify to any of the statements in this contract, such contractor shall attach an explanation to this contract.

4. I understand that a false statement of this certification may be grounds for termination of the contract.

_____ Name of Subrecipient / Contractor / Consultant (Type or Print)	_____ Program Title (Type or Print)
_____ Name of Certifying Official (Type or Print)	_____ Signature
_____ Title of Certifying Official (Type or Print)	_____ Date (Type or Print)



**ATTACHMENT B**

**Certification of Compliance with Wage Payment Statutes and Washington Department of Labor and Industries Training Requirement**

The bidder hereby certifies that, within the three-year period immediately preceding the bid solicitation date (\_\_\_\_\_), the bidder is not a “willful” violator, as defined in RCW 49.48.082, of any provision of chapters 49.46, 49.48, or 49.52 RCW, as determined by a final and binding citation and notice of assessment issued by the Department of Labor and Industries or through a civil judgment entered by a court of limited or general jurisdiction.

As of July 1, 2019, have fulfilled the Department of Labor and Industries’ Public Works and Prevailing Wage Training Requirement before bidding and/or performing work on public works projects under RCW 39.04.350 and RCW 39.06.020 by either of the following:

- 1) Received training on the requirements related to public works and prevailing wage under chapter RCW 39.04.350 and chapter 39.12; or
- 2) Be certified exempt by the Department of Labor and Industries by having completed three or more public work projects and have a had a valid business license in Washington for three or more years.

I certify under penalty of perjury under the laws of the State of Washington that the foregoing is true and correct.

\_\_\_\_\_  
Bidder’s Business Name

\_\_\_\_\_  
Signature of Authorized Official\*

\_\_\_\_\_  
Printed Name

\_\_\_\_\_  
Title

_____ Date	_____ City	_____ State
_____	_____	_____

*Check One:*  
Sole Proprietorship  Partnership  Joint Venture  Corporation   
State of Incorporation, or if not a corporation, State where business entity was formed:

\_\_\_\_\_  
If a co-partnership, give firm name under which business is transacted:

*\* If a corporation, proposal must be executed in the corporate name by the president or vice-president (or any other corporate officer accompanied by evidence of authority to sign). If a co-partnership, proposal must be executed by a partner.*

**ATTACHMENT C**

### Bid Response Summary

**Bid Number** ITB 6185-24  
**Bid Title** Refuse Cranes Quarterly Preventative Maintenance Inspections and Services – Prevailing Wage  
**Due Date** Monday, September 30, 2024 1:00:00 PM [(UTC-08:00) Pacific Time (US & Canada)]  
**Bid Status** Closed to Bidding  
**Company** Wemco Inc.  
**Submitted By** Matt Humphrey - Monday, September 30, 2024 11:21:08 AM [(UTC-08:00) Pacific Time (US & Canada)]  
 mhumphrey@wemcoinc.com 5092444773

**Comments**

**Question Responses**

Group	Reference Number	Question	Response
MANDTORY Pre-Bid			
	#1	A MANDATORY pre-bid conference will be held on MONDAY, SEPTEMBER 23, 2024, at 1:00 pm. The location will be at the Waste to Energy Facility (WTEF) Admin Offices, 2900 S Geiger Blvd., Spokane WA. FIELD VERIFICATION REQUIRED. The Bidder is entirely responsible for inspecting all site conditions prior to submitting a service bid. This meeting is MANDATORY ONLY for those companies who have not previously performed Refuse Cranes Quarterly Preventative Maintenance Inspections and Services at the City of Spokane Waste to Energy Facility.	Acknowledged
CONTACT INFORMATION			
	1	List the following information for the person submitting this response: Company Name, Name, Address, Telephone Number & e-mail address:	WEMCO Inc. Matt Humphrey 5510 West Thorpe Road Spokane, WA 99224 (509)998-5985 mhumphrey@wemcoinc.com
	2	Provide the name, phone number, and email address for the person in your Company that would potentially sign a contract through the DocuSign process used by the City	Matt Turner (509)999-9913 mhumphrey@wemcoinc.com
TECHNICAL GROUP			
	1	Bidder acknowledges it has read and understands Bid # ITB 6185-24.	Acknowledged
	2	How Many Addenda Do You Acknowledge Receipt Of? Please Enter Number. If none were issued enter "0".	2
	3	Please Complete and Upload "Bid Proposal" Pages #15-18 of ITB 6185-24. Upload Here.	Bid Pricing Pages 15-18.pdf



4.	<p>The bid shall be accompanied by a copy of bid bond/bid security payable to the order of the City of Spokane, in an amount of not less than five percent (5%) of the total contract amount. Bid bonds must be by a surety company authorized to do business as a surety in Washington State. As soon as the bid prices have been compared, the City will release the bid security of all except the three (3) lowest responsible bidders. When the service agreement is signed and returned with proof of insurance, the other bid security will be released. If the bidder is awarded the contract and fails to enter into a contract and to provide proof of insurance within the required time period, the bid security shall be forfeited to the City of Spokane. (Blank form available under the 'Documents' tab). In addition to the bid deposit types included in this section, a bidder may have on file with the City Clerk an annual bid bond approved by the City Attorney.</p>	Acknowledged
4.1	<p>Please Complete and Upload "Bid Bond Form" – Page 19 of ITB 6185-24. Upload Here</p>	Bid Bond - ITB 6185-24.pdf
5	<p>Please Complete and Upload "Subcontractor List" – Page 20 of ITB 6185-24. Upload Here</p>	Bid Pricing Page 20.pdf
6	<p>Please Complete and Upload "Supplemental Bidder Responsibility Criteria Form With Work Experience Form" Pages #23 – 28 of ITB 6185-24. Upload Here</p>	Bid Pricing Pages 23-28 - Signed - Final.pdf
6.1	<p>Should Bidder not have provided 'Supplemental Bidder Responsibility Criteria Form With Work Experience Form" above, Bidder acknowledges after bid opening and prior to award, the apparent low bidder, or contacted bidders, shall complete, sign and submit this form with attached documentation within twenty four (24) hours of notification.</p>	Acknowledged
7	<p>Bidder acknowledges there may be a need for unscheduled, emergency services should crane failure be incurred, in which case response time is critical vendor must be on-site within 2 hours of notification.</p>	Acknowledged
8	<p>Acknowledge that that you have read and understand Liquidate Damages of the bid.</p>	I Acknowledge and Agree
9	<p>If you took exception to any of the above, explain in detail.</p>	
<p><b>TERMS AND CONDITIONS</b></p>		
<p></p>		

1	Bidder accepts the Terms and Conditions of this ITB in accordance with the document so named in the 'Documents' tab. Should Bidder have selected "Acknowledged With Exceptions" to acceptance of Terms and Conditions as set forth in ITB document so named in the 'Documents' tab, Bidder must submit requested exceptions document with its Bid. The City will consider and determine if exception will be accepted.	Acknowledge
1.1	EXCEPTION: If you took exception to above, upload here.	
2	ELIGIBILITY FOR CITY CONTRACTS: Section 18.09.050 of the Spokane Municipal Code states that the recipient of a City contract, award or purchase order shall certify that it is not knowingly or intentionally a nuclear weapons producer. The Bidder certifies that his/her firm is not a nuclear weapons producer.	I Certify
ADDITIONAL DOCUMENTS BIDDER WOULD LIKE TO UPLOAD		
1	If you have additional information/documents to submit, upload them here.	Addendum 1 ITB 6185-24 - Signed.pdf
2	If you have additional information/documents to submit, upload them here.	Addendum 2 ITB 6185-24 - Signed.pdf
3	If you have additional information/documents to submit, upload them here.	WOSB Certification Certificate Expires 1-31-2025.pdf
4	If you have additional information/documents to submit, upload them here.	Safety Ratings - ITB 6185-24.pdf

**Addendum 1**  
**9/23/2024**

ITB 6185-24

**Refuse Cranes Quarterly Preventative Maintenance Inspections and Services – Prevailing Wage**

**PLEASE NOTE: A SIGNED COPY OF THIS ADDENDUM SHOULD BE SUBMITTED WITH YOUR BID, OR THE BID MAY BE CONSIDERED NON-RESPONSIVE.**

Addendum 1 provides questions and responses that were asked during the Mandatory Pre-Bid Conference that was held Monday, September 23, 2024 at 1:00 pm., at the Waste to Energy Facility (WTEF) Admin Offices, 2900 S Geiger Blvd., Spokane WA. The meeting was MANDATORY ONLY for those companies who have not previously performed Refuse Cranes Quarterly Preventative Maintenance Inspections and Services at the City of Spokane Waste to Energy Facility. Addendum also provides a copy of the sign-in sheet.

QUESTIONS, No Questions Were Asked.

ITB 6185-24 Refuse Cranes Qrtly Preventative Maint Inspections & Services - Prevailing Wages			
MANDATORY PRE-BID CONFERENCE. A MANDATORY pre-bid conference held Monday, September 23, 2024 at 1:00 pm., at the Waste to Energy Facility (WTEF) Admin Offices, 2900 S Geiger Blvd., Spokane WA. <u>This meeting is MANDATORY ONLY for those companies who have not previously performed Refuse Cranes Quarterly Preventative Maintenance Inspections and Services at the City of Spokane Waste to Energy Facility.</u>			
Company Name	Individual's Printed Name	Signature	Email address
WEMCO Inc	Math Humphrey	<i>Matthew Humphrey</i>	mhumphrey@wemcoinc.com

Rick Rinderle  
Procurement Specialist

The undersigned acknowledges receipt of this Addendum.

**WEMCO, Inc.**

---

Company

Matthew L Humphrey

---

Signature

Digitally signed by Matthew L. Humphrey  
DN: C=US, E=mhumphrey@wemcoinc.com,  
O=WEMCO Inc., CN=Matthew L. Humphrey  
Reason: I am approving this document  
Date: 2024.09.30 10:11:31-0700

**Addendum 2**  
**9/25/2024**

ITB 6185-24

**Refuse Cranes Quarterly Preventative Maintenance Inspections and Services – Prevailing Wage**

**PLEASE NOTE: A SIGNED COPY OF THIS ADDENDUM SHOULD BE SUBMITTED WITH YOUR BID, OR THE BID MAY BE CONSIDERED NON-RESPONSIVE.**

Addendum 2 make the following changes:

Addendum 2, ITB 6185-24, has been posted in the Documents tab, makes the following changes:  
Bid Document “.ITB 6185-24 Refuse Crane Inspection Document” has since been removed from the External Documents tab and replaced with titled document: “.ITB 6184-24 (Addendum 2 Bid Document 9-25-2024 Refuse Crane Inspections Document, that made the one below change:

16. **EXECUTION OF CONTRACT.** (Addendum 2, 9/25/2024)

Text Removed: ~~and payment/performance bonds~~

The undersigned acknowledges receipt of this Addendum.

**WEMCO, Inc.**

---

Company

Matthew L Humphrey

---

Digitally signed by Matthew L Humphrey  
DN: c=US, email=ermlumh@wemcoinc.com,  
o=WEMCO Inc., cn=Matthew L Humphrey  
Reason: I am approving this document  
Date: 2024.09.30 10:12:02-0700

Signature

**These Next Six Pages (Pages #15 – 18) Comprising Bid Proposal Must Be Completed and Uploaded Into ProcureWare Via The Question Tab and corresponding question #3.**

**BID PROPOSAL**

**PROJECT:** # ITB 6185-24

Refuse Cranes Quarterly Preventative Maintenance Inspections and Services For Two 9-Ton, Top-Running Double Girder (TRDG) Bridge Cranes – Prevailing Wages

**BIDDER'S DECLARATION.**

The undersigned bidder certifies that it has examined the site, read and understands the specifications for the above project, and agrees to comply with all applicable federal, state and local laws and regulations. The bidder is advised that by signature of this bid proposal it has acknowledged all bid requirements and signed all certificates contained herein.

**BID OFFER.**

The price(s) listed in this bid proposal is tendered as an offer to furnish all labor, materials, equipment, and supervision required to complete the proposed project in strict accordance with the contract documents. The bidder proposes to do the services at the following price:

January 1, 2025 Through December 31, 2025:

<b>SCHEDULED SERVICES</b>	
Total Number Of Hours Required To Complete All Work and Requirements Associated With "Four Quarterly Inspects pertaining to two refuse cranes, 9-Ton, Top-Running Double Girder (TRDG) Bridge Cranes".	<u>160</u> hrs. Total Annual Hrs. Required
Total Labor Cost for To Complete All Work and Requirements Associated With Four Quarterly Inspects	\$ <u>28,480.00</u> Total Annual Labor Cost Labor To Be Incurred
Total Equipment & Materials Cost, <u>Plus Vendor's Percentage Markup Above Vendor's Cost</u> , To Complete All Work and Requirements Associated With Four Quarterly Inspects.	\$ <u>12,400.00</u> Total Annual Material/Equipment Cost
Annual Subtotal	\$ <u>40,880.00</u>
Applicable Tax ( Rate 9%)	\$ <u>3,679.20</u>
<b>Extended Total Annual Cost To Be Incurred To Complete All Work and Requirements Associated With Four Quarterly Inspection</b>	<b>\$ <u>44,559.20</u></b>

UNSCHEDULED SERVICES	
Unscheduled Non-Emergency	Non-Emergency Repairs. Contractor shall be on site with 24 hours, unless a different response is mutually agreed upon and coordinated between Contractor and WTEF Maintenance Supervisor.
Unscheduled Emergency	<b>Emergency Calls, Contractor shall be on site within 2 hours of notification</b>
Straight Time Hourly Rate	<b>\$178.00</b> Hourly Rate
Straight Time Defined	<b>6:00AM - 2:30PM, Monday-Friday</b>
Overtime Hourly Rate	<b>\$ 235.00</b> Hourly Rate
Overtime Rate Defined	<b>2:30PM - 6:00AM, Monday-Thursday</b>
Emergency Work Hourly Rate After Straight Rate	<b>\$ 235.00</b> Hourly Rate
Emergency Work Rate Defined	<b>After 2:30PM Friday - 6:00AM Monday</b>
Holiday Hourly Rate	<b>\$ 315.00</b> Hourly Rate
Holiday Rate Defined	<b>New Year's Day, Memorial Day, Independence Day, Labor Day, Thanksgiving Day, Christmas Eve, Christmas Day</b>
Travel Cost Per "Unscheduled Service"	<b>\$ 0.00</b>
Define Travel Cost Per "Unscheduled-Service":	<b>No Travel Charge</b>
Vendor's Percentage Markup Above Vendor's Cost For Any Parts and Materials Determined To Be Needed As Result Of Inspection, or that is required as a result of Unscheduled-Service request. Vendor would be responsible for installing/replacing under resulting contract at applicable hourly contract rate. <b>Percentage Markup will remain unchanged throughout the five-year contract period.</b> Enter Percentage Markup Above Vendor's Cost Here.	<u>          20          </u> %
Applicable Tax	9.00%

**ADDENDA.**

The undersigned acknowledges receipt of addenda number(s)           2           and agrees that their requirements have been included in this bid proposal.

**PERIOD OF PERFORMANCE.**

The bidder agrees the period of performance of any contract resulting from this ITB is tentatively scheduled to begin on or about January 1, 2025, and to end on December 31, 2029.

**LIQUIDATED DAMAGES.**

In the event the bidder is awarded the contract and fails to complete the work within the time limit or any agreed upon time extensions, liquidated damages shall be paid to the City of Spokane in the amount of Ten thousand Dollars (\$10,000.00) per working day until the work is satisfactorily completed.

**BIDDER RESPONSIBILITY.**

Washington State Contractor's Registration No. CC WASHIEM099QK  
(must be in effect at time of bid submittal)

U.B.I. Number 601-174-038

Washington Employment Security Department Number 000-669191-00-5

Washington Excise Tax Registration Number 601-174-038

City of Spokane Business License Number T12002901BUS  
(The successful bidder and all subcontractors shall be licensed or have applied for a license to do business in the City of Spokane prior to proceeding with the proposed project.)

**BID SECURITY.**

A bid security in the amount of FIVE PERCENT (5%) of the total project bid as indicated above, is attached to this bid proposal. If the bidder is awarded the contract and fails to enter into a construction contract and/or furnish payment / performance bond(s) and proof of insurance within the required time period, the bid security shall be forfeited to the City of Spokane.

**NON-COLLUSION.**

The undersigned authorized representative of the undersigned firm, being first sworn on oath, certifies that the firm has not, directly or indirectly, entered into any agreement, participated in any collusion, or otherwise taken any action in restraint of free competitive bidding in connection with the project for which this bid proposal is submitted.

Name of Bidder: WEMCO, Inc.

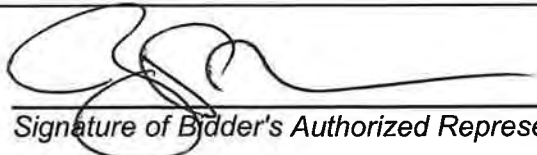
  
*Signature of Bidder's Authorized Representative*

VP  
Title

5510 W. Thorpe Rd.  
Spokane, WA 99224  
Address

509-244-4773

Phone \_\_\_\_\_

**IF INDIVIDUAL**

Signed and Sworn To (or Affirmed) Before Me On \_\_\_\_\_  
date

(Seal Or Stamp)

\_\_\_\_\_  
Signature of Notary Public

My appointment expires \_\_\_\_\_

**IF PARTNERSHIP**

I certify that I know or have satisfactory evidence that the above named person signed this bid proposal, on oath stated that he/she was authorized to sign it and acknowledged it as the partner(s) of the bidder, a partnership, to be the free and voluntary act of such party for the uses and purposes herein mentioned.

Signed and Sworn To (or Affirmed) Before Me On \_\_\_\_\_  
date

(Seal Or Stamp)

\_\_\_\_\_  
Signature of Notary Public

My appointment expires \_\_\_\_\_

**\* IF CORPORATION**

I certify that I know or have satisfactory evidence that the above named person signed this bid proposal, on oath stated that he/she was authorized to sign it and acknowledged it as the representative of the bidder, a corporation, to be the free and voluntary act of such party for the uses and purposes herein mentioned.

Signed and Sworn To (or Affirmed) Before Me On 9/30/2024  
date

(Seal Or Stamp)

  
\_\_\_\_\_  
Signature of Notary Public

My appointment expires 1-19-2028





**This Page (Page #19) Must Be Completed and Uploaded Into ProcureWare Via The Question Tab and corresponding question #4.**

**BID BOND**

We, Washington Equipment Manufacturing Company, Inc. dba WEMCO as Principal,  
and Merchants Bonding Company (Mutual) as Surety,  
are held and firmly bound unto the CITY OF SPOKANE, a Washington State municipal  
corporation, in the penal sum of FIVE PERCENT (5%) OF THE TOTAL AMOUNT BID, for the  
payment of which we jointly and severally bind ourselves, and our legal representatives and  
successors.

THE CONDITIONS OF THE OBLIGATION are that if the City of Spokane shall make  
timely award to the Principal for the

**Refuse Cranes Quarterly Preventative Maintenance Inspections and Services For Two  
9-Ton, Top-Running Double Girder (TRDG) Bridge Cranes – Prevailing Wages**

according to the terms of the bid made by the Principal; and the Principal shall, within the  
specified time, enter into a contract with the City of Spokane and furnish bond(s) acceptable to  
the City, if required, then this obligation shall be null and void; otherwise it shall remain in full  
force and effect; but in no event will the surety's liability exceed this bond's face amount.

SIGNED AND SEALED on September 30, 2024

AS PRINCIPAL

Washington Equipment Manufacturing Company, Inc. dba WEMCO

By:  \_\_\_\_\_

Title: VP \_\_\_\_\_

A valid POWER OF  
ATTORNEY must  
accompany this bond.

Merchants Bonding Company (Mutual)

AS SURETY

By:  \_\_\_\_\_

PO Box 14498, Des Moines, IA 50306-3498  
Address

509-747-3121  
Phone

Attorney in Fact, Travis Long

**MERCHANTS**  
**BONDING COMPANY™**  
**POWER OF ATTORNEY**

Know All Persons By These Presents, that MERCHANTS BONDING COMPANY (MUTUAL) and MERCHANTS NATIONAL BONDING, INC., both being corporations of the State of Iowa, d/b/a Merchants National Indemnity Company (in California only) (herein collectively called the "Companies") do hereby make, constitute and appoint, individually,

Daniel J Stowe; H Keith McNally; Ryan Pugh; Shelby Groth; Sydney Schmidt; Travis Long; WM Dinneen

their true and lawful Attorney(s)-in-Fact, to sign its name as surety(ies) and to execute, seal and acknowledge any and all bonds, undertakings, contracts and other written instruments in the nature thereof, on behalf of the Companies in their business of guaranteeing the fidelity of persons, guaranteeing the performance of contracts and executing or guaranteeing bonds and undertakings required or permitted in any actions or proceedings allowed by law.

This Power-of-Attorney is granted and is signed and sealed by facsimile under and by authority of the following By-Laws adopted by the Board of Directors of Merchants Bonding Company (Mutual) on April 23, 2011 and amended August 14, 2015 and adopted by the Board of Directors of Merchants National Bonding, Inc., on October 16, 2015.

"The President, Secretary, Treasurer, or any Assistant Treasurer or any Assistant Secretary or any Vice President shall have power and authority to appoint Attorneys-in-Fact, and to authorize them to execute on behalf of the Company, and attach the seal of the Company thereto, bonds and undertakings, recognizances, contracts of indemnity and other writings obligatory in the nature thereof."

"The signature of any authorized officer and the seal of the Company may be affixed by facsimile or electronic transmission to any Power of Attorney or Certification thereof authorizing the execution and delivery of any bond, undertaking, recognizance, or other suretyship obligations of the Company, and such signature and seal when so used shall have the same force and effect as though manually fixed."

In connection with obligations in favor of the Florida Department of Transportation only, it is agreed that the power and authority hereby given to the Attorney-in-Fact includes any and all consents for the release of retained percentages and/or final estimates on engineering and construction contracts required by the State of Florida Department of Transportation. It is fully understood that consenting to the State of Florida Department of Transportation making payment of the final estimate to the Contractor and/or its assignee, shall not relieve this surety company of any of its obligations under its bond.

In connection with obligations in favor of the Kentucky Department of Highways only, it is agreed that the power and authority hereby given to the Attorney-in-Fact cannot be modified or revoked unless prior written personal notice of such intent has been given to the Commissioner-Department of Highways of the Commonwealth of Kentucky at least thirty (30) days prior to the modification or revocation.

In Witness Whereof, the Companies have caused this instrument to be signed and sealed this 25th day of June, 2024.



MERCHANTS BONDING COMPANY (MUTUAL)  
MERCHANTS NATIONAL BONDING, INC.  
d/b/a MERCHANTS NATIONAL INDEMNITY COMPANY

By

*Larry Taylor*  
President

STATE OF IOWA  
COUNTY OF DALLAS ss.

On this 25th day of June, 2024, before me appeared Larry Taylor, to me personally known, who being by me duly sworn did say that he is President of MERCHANTS BONDING COMPANY (MUTUAL) and MERCHANTS NATIONAL BONDING, INC.; and that the seals affixed to the foregoing instrument are the Corporate Seals of the Companies; and that the said instrument was signed and sealed in behalf of the Companies by authority of their respective Boards of Directors.

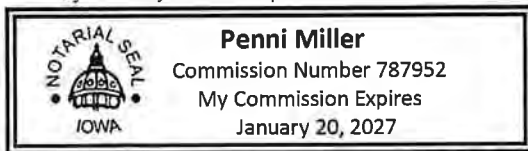

(Expiration of notary's commission does not invalidate this instrument)

*Penni Miller*  
Notary Public

I, William Warner, Jr., Secretary of MERCHANTS BONDING COMPANY (MUTUAL) and MERCHANTS NATIONAL BONDING, INC., do hereby certify that the above and foregoing is a true and correct copy of the POWER-OF-ATTORNEY executed by said Companies, which is still in full force and effect and has not been amended or revoked.

In Witness Whereof, I have hereunto set my hand and affixed the seal of the Companies on this 30th day of September, 2024.



*William Warner Jr.*  
Secretary

This Page (Page #19) Must Be Completed and Uploaded Into ProcureWare Via The Question Tab and corresponding question #5.

# SUBCONTRACTOR LIST

**City of Spokane Project Name: ITB 6185-24, Refuse Cranes Quarterly Preventative Maintenance Inspections and Services For Two 9-Ton, Top-Running Double Girder (TRDG) Bridge Cranes – Prevailing Wages**

*This form is to be submitted with the Bid Proposal, or within one (1) hour after the published bid submittal time, unless bidder had submitted it with its bid response.*

**RCW 39.30.060 (as amended) states:**

*“Every invitation to bid on a prime contract that is expected to cost one million dollars or more for the construction, alteration, or repair of any public building or public work ... shall require each prime contract bidder to submit as part of the bid, or within one (1) hour after the published bid submittal time, the names of the subcontractors with whom the bidder, if awarded the contract, will subcontract for performance of the work of: electrical as described in chapter 19.28 RCW, or to name itself for the work.*

***The prime contract bidder shall not list more than one (1) subcontractor for each category of work identified, unless subcontractors vary with bid alternates, in which case the prime contract bidder must indicate which subcontractor will be used for which alternate. Failure of the prime contract bidder to submit as part of the bid the names of such subcontractors or to name itself to perform such work or the naming of two or more subcontractors to perform the same work shall render the prime contract bidder's bid nonresponsive and, therefore, void.**” (emphasis added)*

**Subcontractor Named (List prime contract bidder if prime contract bidder intends to self-perform the work):** \_\_\_\_\_ **NO SUBCONTRACTORS WILL BE USED**

**Work to be performed:**

\_\_\_\_\_

**Subcontractor Named: (List prime contract bidder if prime contract bidder intends to self-perform the work)** \_\_\_\_\_

**Work to be performed:**

\_\_\_\_\_

**Subcontractor Named (List prime contract bidder if prime contract bidder intends to self-perform the work):** \_\_\_\_\_

**Work to be performed:**

\_\_\_\_\_

**Subcontractor Named (List prime contract bidder if prime contract bidder intends to self-perform the work):** \_\_\_\_\_

**Work to be performed:**

\_\_\_\_\_

**Subcontractor Named (List prime contract bidder if prime contract bidder intends to self-perform the work):** \_\_\_\_\_

**Work to be performed:**

\_\_\_\_\_

Next Six Pages (Pages #23 – 28, plus as needed) Completed and Uploaded Into ProcureWare Via The Question Tab and corresponding question #6, else provide within 24 hours after notification.



## City of Spokane, Washington Supplemental Bidder Responsibility Criteria

Should Bidders not have shall completed, sign and submit this form with attachments with Bid, then after bid opening and prior to award, the apparent low bidder, or those bidder contacted, shall complete, sign and submit this form with attachments to the City (See instructions at the end of this form). The form shall be submitted within twenty four (24) hours after the notification, unless a different time and date is required by the specifications or otherwise mutually agreed upon.	
Project Name: <b>Quarterly Crane, Hoist, Trolley and Lifeline Preventative Maintenance Inspections and Services – Prevailing Wages.</b>	
Project # <b>ITB 6184-24</b>	
<b>Part A: General Company Information</b>	
Company Name	
Address	
Contact Name and Title	
Contact Phone	Contact E-mail
Years in business as a Prime Contractor	Years in business as a sub-contractor
Years in business under present Name	
List any former company names under which the company, its owners, and/or its principals has operated in the past five (5) years	
Explain reason for name change(s) in the past five (5) years	
<b>Part B: Work Experience</b>	
If the request for bids has project specific criteria, including work experience, list at least the requested number of projects (or a minimum of two projects if a requested number was note stated) completed within the required time frame (last five years) on the attached Project Experience form which are similar in type, size and scope of work required for this project	
<b>Part C: Performance Evaluation</b>	
Under past or present names does the bidder have a history of receiving “deficient” or “inadequate” evaluations on two (2) or more contracts from the City or other municipalities or another governmental agency on a public works project within the last five (5) years?	
<input type="checkbox"/> Yes <input type="checkbox"/> No	
If “Yes” attach a separate, signed / dated statement listing the projects and an explanation.	
<b>Part D: Record of Debarment / Disqualification</b>	

Has the bidder (including the primary contractor, any firm with which any of the primary contractor's owners, officers, or partners was associated) been debarred, disqualified, removed or has been otherwise prevented from bidding on, or completing any governmental agency or public works projects, including debarment by the federal, state or other municipal government during the last five (5) years?
<input type="checkbox"/> Yes <input checked="" type="checkbox"/> No
If "Yes", attach a separate signed / dated statement listing any debarments, disqualifications, removal, etc. from any governmental public works project and the basis for the action.
<b>Part E: Safety</b>
In the last five (5) years, has the bidder received willful or repeat violations of safety or health regulations by the OSHA or other agencies responsible for safety oversight? The Contractor shall submit safety records for the past three (3) years including OSHA 300A logs, recordable incidents, lost time accident statistics, EMR rating, OSHA type violations and NAICS code. The Contractor shall submit a list of any work activities previously performed at the City of Spokane WTEF. It is expected the contractor will have an EMR rating <1, OSHA recordable rate below industry average and no OSHA Violations for the past 3 years.
<input type="checkbox"/> Yes <input checked="" type="checkbox"/> No
If "Yes," attach a separate signed /dated statement describing each willful or repeat violation, including information about the dates and nature of the violations, the project on which the citation(s) was or were issued, the amount of penalty paid, if any. If the citation was appealed and a decision has been issued, state the case number and the date of the decision.
<b>Part F: Environmental</b>
In the last five (5) years, has the bidder received serious citations from government environmental enforcement agencies on projects for which the bidder was the contractor?
<input type="checkbox"/> Yes <input checked="" type="checkbox"/> No
If "Yes," attach a separate signed / dated statement describing each serious citation, including information about the dates of the citations, the nature of the violation, the project on which the citation(s) was or were issued, the amount of penalty paid, if any. If the citation was appealed and a decision has been issued, state the case number and the date of the decision.
<b>Part G: Discrimination</b>
Has the bidder or any of its owners, officers or partners been found guilty of violating or failing to comply with discrimination laws in contracting, employment or provision of public services?
<input type="checkbox"/> Yes <input checked="" type="checkbox"/> No
If "Yes", attach a separate signed / dated statement identifying the type of violation, who was involved, the name of the public agency, year of the investigation, the resolution in court or administrative process, and the grounds for the findings.
<b>Part H. Prevailing Wage</b>
In the last five (5) years, has the bidder received prevailing wage violations as determined by the applicable state or federal government agency monitoring prevailing and/or Davis Bacon wage compliance?
<input type="checkbox"/> Yes <input checked="" type="checkbox"/> No

<p>If “Yes,” attach a separate signed/dated statement listing the prevailing wage violations, along with an explanation of each violation and how it was resolved. The City shall evaluate these explanations and the resolution of each violation to determine whether the violations demonstrate a pattern of failure to pay prevailing wages to workers unless there are extenuating circumstances acceptable to the City.</p>
<p><b>Part I. Claims Against Retainage and Bonds</b></p>
<p>Does the bidder have a record of multiple claims filed against the retainage or payment bonds for public works projects during the previous three (3) years?</p>
<p><input type="checkbox"/> Yes      <input checked="" type="checkbox"/> No</p>
<p>If “Yes”, attach a separate signed / dated statement listing the claims filed against the retainage and/or payment bond for any completed public works projects and include for each project a written explanation of the circumstances surrounding the claim and the ultimate resolution of the claim. The City shall evaluate the statement to determine if it demonstrates a lack of effective management by the bidder of making timely and appropriate payments, unless there are extenuating circumstances acceptable to the City in its sole discretion.</p>
<p><b>Part J. Termination for Cause</b></p>
<p>Has the bidder had any public works contract terminated for cause by any government agency during the previous five (5) years?</p>
<p><input type="checkbox"/> Yes      <input checked="" type="checkbox"/> No</p>
<p>If “Yes”, attach a separate signed / dated statement listing each contract terminated, the government agency terminating the contract and the circumstances involving the termination for cause. The City will determine if there are extenuating circumstances acceptable to the City in its sole discretion.</p>
<p><b>Part K: Litigation</b></p>
<p>Has the bidder been involved in lawsuits (or arbitrations for those instances where arbitration is completed in lieu of a lawsuit) with judgments entered against the bidder for failure to meet terms on contracts in the previous five (5) years?</p>
<p><input type="checkbox"/> Yes      <input checked="" type="checkbox"/> No</p>
<p>If “Yes”, attach a list of lawsuits and/or arbitrations with judgments / arbitration awards entered against the bidder along with a written explanation of the circumstances surrounding each lawsuit and/or arbitration. The City will evaluate the explanations to determine whether the lawsuits and/or arbitrations demonstrate a pattern of failing to meeting terms of conditions of contracts, unless there are extenuating circumstances acceptable to the City in its sole discretion.</p>
<p><b>Part L: Delinquent State Taxes</b></p>
<p>Does the bidder owe delinquent taxes to the Washington State Department of Revenue without a payment plan approved by the Department before the date of contract award?</p>
<p><input type="checkbox"/> Yes      <input checked="" type="checkbox"/> No</p>
<p>If “Yes”, attach a separate signed / dated statement describing the circumstances and stating that the bidder is not on the Washington State Department of Revenue’s “Delinquent Taxpayer List”.</p>
<p><b>Part M: Subcontractor Responsibility</b></p>
<p>Does the bidder’s standard subcontract form include the subcontractor language required by RCW 39.06.020? Does the bidder have an established procedure which it uses to validate the responsibility of each of its subcontractor? Does the subcontract form require that each of the bidder’s subcontractors have and document a similar procedure for sub-tier subcontractors?</p>

<input type="checkbox"/> Yes <input checked="" type="checkbox"/> No	
If "Yes" or "No", provide a copy of its standard subcontract form and a copy of the procedures used to validate the responsibility of subcontractors.	
<b>Signature</b>	
The undersigned certifies that the information and data contained herein is correct and complete. Failure to disclose information or submitting false or misleading information may result in rejection of my bid, revocation of award, contract termination, or may impact my firm's ability to bid on future projects by the City of Spokane.	
Signature of Authorized Representative	Date
	9/30/2024
Printed Name of Authorized Representative	Title
Matthew L Humphrey	Part Sales & Service Coordinator

## Attachment to Supplemental Bidder Responsibility Criteria

### Work Experience Form

Please complete one form per project and include the minimum number of projects (and forms) as requested. You may include any additional work experience you deem relevant in determining bidder responsibility. Please be sure to provide a thorough description of the work in order to demonstrate how your firm meets any required experience detailed in the specifications. You may attach additional documentation if needed.			
<b>PROJECT DETAIL</b>			
Bidder's Company Name  WEMCO, Inc.		Bidders Contact Name & Phone Number  Matt Humphrey, 509-244-4773	
Project Name Quarterly Crane/Hoist/Trolley and Lifeline Preventative Maintenance Inspections and Unscheduled Services		Project Contract Number OPR 2019-0959	
Project Owner City of Spokane		Project Location City of Spokane - WTEF	
Project Owner Contact Name & Title David Paine		Owner's Telephone Number (509)625-6878	
Notice to Proceed Date Current 5th Year Contract - 1/1/2024	Final Completion Date Current 5th Year Contract - 12/31/2024	Awarded Contract Value \$60,000.00	Final Contract Price \$60,000.00
Prime Contractor Name (If Not Bidder)  N/A		Contractor Contact Name & Phone Number (If Not Bidder)  N/A	
Brief Project Description  Quarterly Crane/Hoist/Trolley and Lifeline Preventative Maintenance Inspections and Unscheduled Services			
Brief Summary Of Technical Work Completed By Bidder, Including Any Relevant Details To Demonstrate Similar Experience And Any Required Experience Detailed In the Specifications Performed Quarterly Inspections and As Needed Repairs to Cranes, Hoists and Lifelines at WTEF for the City of Spokane the past 4.75 years. We continuously strive to provide thorough inspections of equipment for our clients to keep their employees safe and downtime to a minimum.			



## Instructions for the Supplemental Bidder Responsibility Form

<p>After bid opening and prior to award, the apparent low bidder shall complete, sign and submit this form with attached documentation to the City of Spokane Purchasing Section by one of the methods listed below within twenty four (24) hours of notification.</p>
<p>The City’s evaluation may include further investigations to establish the responsibility, qualifications, financial resources and experience of a bidder to complete the work of this contract. The City may contact previous owners or others to validate the information provided by the bidder. The City will assess the information provided and other information gathered in determining whether a bidder is responsible. List all information you feel is relevant to the City making an informed decision. The City reserves the right to request additional information from the bidder.</p>
<p>For criteria with check boxes, the bidder will check either “Yes” or “No. ” For each “Yes” answer on the form, the Bidder shall provide a signed and dated statement providing the project information requested and explaining the extenuating circumstances.</p>
<p><b>Form Submittal:</b></p>
<p>Submit this form to Purchasing Department by one of the following methods within twenty four (24) hours after the time of notification (unless the specifications provide a different time or date)</p>
<p>Emails (preferable)      <a href="mailto:RRinderle@spokanecity.org">RRinderle@spokanecity.org</a></p>
<p style="text-align: center;">with the Email Subject line: Supplemental Bidder Form for City of Spokane Quarterly Crane, Hoist, Trolley and Lifeline Preventative Maintenance Inspections and Services – Prevailing Wages.</p>
<p>Questions: Please call (509) 625-6527</p>

# LIBBY DAM 300-TON POWERHOUSE GANTRY CRANE REHAB



📍 Libby, MT

✂ Firm Role: Prime Contractor

🔊 Delivery Method: Design-Build

## CONTRACT NUMBER:

W912DW20F2045

**START DATE:** 7/15/2020

## SUBSTANTIAL COMPLETION:

2/22/2022

## ORIGINAL ESTIMATE:

\$5,587,000

## FINAL CONTRACT VALUE:

\$6,168,865

**CAPACITY (IN TONS):** 300

**SPAN (IN FEET):** 63

## PROJECT RELEVANCY:



New Component Design & Install



Occupied Facility



Over 15-Ton & 50' Span



Synchronized Trolleys on the Same Crane



Lead & Asbestos Abatement Work Completed



Low Headroom Constraints



Replacement of Runway Conductor Bar & Feeder Upgrades



Demolition of Existing Equipment



## PROJECT SUMMARY

Garco WEMCO JV was awarded the contract to perform the rehabilitation of the Libby Dam 300-ton Powerhouse Gantry Crane. Our team designed and engineered the complete replacement of the two traveling hoist trolleys, each of which features a 150-ton main hoist and a 25-ton aux hoist. Additionally, our team replaced a 15-ton bulkhead high lift hoisting system used in a dynamic river environment. This replacement included the bulkhead hoist platform that the bulkhead hoist mounts to, which is analogous to a stationary trolley rigid mounted to the side of the gantry structure. The replacement of the platform required detailed structural analysis, including the structural engineering review of the gantry structure connection points and load paths into the structure's legs.

This project also involved the redesign of an existing cab. The refurbished cab features a boom mounted PLC monitor, JR Merit chair and controls, radio controller, and camera system for monitoring several travel and hoisting operations on the crane. The control system includes the incorporation of load cells that will allow the monitoring of combined loads when using multiple hoists.

This crane rehabilitation required the design of a new control system configured to fit inside the crane girders. To ensure Garco WEMCO JV could accommodate the new control system into the existing area available inside the gantry cranes girders and legs, the team performed an on-site survey of the inside and outside of the crane using Leica 3D scanners. The team then converted this scanned data into the CAD software to compare it to the owner-provided original construction prints. Utilizing these technological tools allowed our team to model the new control system panels into the inside of the crane in real space to confirm everything would fit. The control system consists of a closed loop flux vector VFD controlled hoisting and scalar volts per hertz VFD set travel drives.

Additionally, sizing new mechanical components and fitting them into allowable spaces on the existing equipment was a challenge. Extreme caution was taken to allow the critical features of the crane such as overall lift heights, head room, and max travels not to change outside of the operating parameters of the specification.

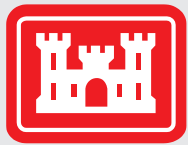
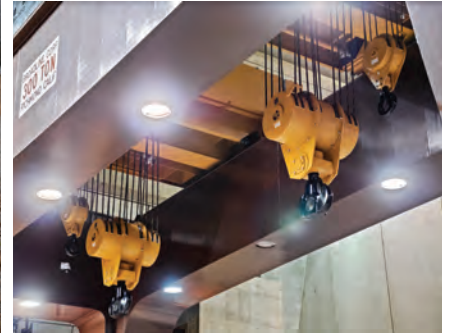

## US Army Corps of Engineers®

### RELEVANT TEAM MEMBERS:

- Juston Rouse, Lead Estimator/  
Project Executive
- Matt Turner, Project Manager
- Hollis Barnett, Project Executive
- Casey Stulc, P6 Scheduler/  
Garco Project Manager
- Nick Creel, Superintendent
- Curtis Puckett, Quality Control  
Manager
- Jacob Culley, DOR Mechanical
- James Beckley, On-site Foreman
- Justin Almeida, Lead Service Tech
- Matt Humphrey, NCCCO Crane  
Inspector

The newer and larger gearboxes and equipment configurations had to be taken into careful consideration. This rehabilitated equipment was more robust than the existing to accommodate current performance specifications. It was also extremely important to confirm locations were figured exactly to the old equipment for proper use after completion.

Manufacturing for this project included the following systems designed and engineered by the Garco WEMCO JV: fabrication of new structures for the gantry frame, fabrication of two new traveling trolleys, two new main hoists 150-ton, two new aux hoists 30-ton, one new bulkhead gate hoist, with new lifting beam, newly renovated cab with complete control systems including integrated cameras and new gantry drives. This project also included the complete rehabilitation of the project's lifting devices for the crane, including structural and mechanical analysis complete inspection, and weld repair and load testing with repainting.

Installing newly designed and manufactured components on an existing crane structure within an operating facility required close communication and coordination with the USACE team. Garco WEMCO JV developed multiple construction site plans to communicate approach prior to beginning work on site. Due to site constraints associated with working inside an existing dam, early planning helped to ensure success once the construction team arrived on site. The plans included 3-D models to verify temporary installation equipment layout did not conflict with the existing dam structure or components. The JV team utilized a mobile crane to remove existing crane equipment and install newly manufactured equipment. The JV team performed structural analysis to confirm the mobile crane setup/loading would not impact or damage the existing structure. Equipment install, testing, and commissioning completed as planned in February 2022.



### OWNER CONTACT

Bradley Brandt, PR, United States Army Corps of Engineers  
p: 509.244.5572 e: [bradley.r.brandt@usace.army.mil](mailto:bradley.r.brandt@usace.army.mil)

# OAHE POWERPLANT BRIDGE CRANE REHAB



📍 Pierre, SD

✂ Firm Role: General Contractor

📣 Delivery Method: Design-Build

## CONTRACT NUMBER:

W9128F18C002

**START DATE:** 12/1/2017

## SUBSTANTIAL COMPLETION:

7/30/2021

## ORIGINAL ESTIMATE:

\$4,465,541

## FINAL CONTRACT VALUE:

\$8,139,969

**CAPACITY (IN TONS):** (2) 250

**SPAN (IN FEET):** 70

## PROJECT RELEVANCY:



Walkway System Upgrades



New Component Design & Install



Crane Lighting Addition



Over 15-Ton & 50' Span



Synchronized Trolleys on the Same Crane



Synchronized Bridge Cranes on the Same Runway



Active Occupied Facility



Lead & Asbestos Abatement Work Completed



Low Headroom Constraints



Rail Survey & Adjustments



Replacement of Runway Conductor Bar & Feeder Upgrades



Demolition of Existing Cranes & Equipment



## PROJECT SUMMARY

WEMCO proposed on and was awarded the Oahe Powerplant Bridge Crane Rehab Project to perform the mechanical and electrical rehabilitation on two 250-Ton bridge cranes. The project requirements had extensive inspection work on all mechanical and structural components of the crane, inspections included non-destructive testing of all welds and load-bearing elements. A review of the inspection reports showed the cranes needed substantial upgrade work that was not originally included in the base contract. WEMCO's third-party weld inspections showed cracked and inconsistent welding, not meeting the AWS code requirements on 80% of the four hoist trolleys. Further, the hoist drums had cracks in the welds at the shaft hubs and spoke plates, and numerous other deficiencies accompanied these significant concerns, including cracked sheaves and steel-on-steel connections in the cranes end truck bogie pins, final gearing on three of the four aux hoist systems was misaligned and severely worn. Based on WEMCO's analyses, the Government agreed that additional work was required to bring the cranes into compliance with industry standards and make them safe to operate. As such, the Government issued a Contract Modification for the complete replacement of all four hoist trolleys on the cranes. The additional scope is represented in the increase from the original to final contract shown above.

As with its other work, WEMCO provided a quality product, not only maintaining the AS9100 and ISO9001D certified manufacturer environment, but also completing critical paintwork under WEMCO's SSPC QP 3 certification. WEMCO's fabricators hold multiple AWS welding certifications, including AWS D1.1, D14.1, D1.6, and D1.5 (fracture critical). Applying this vast knowledge and experience, the new fabrication on the four new hoist trolleys was held to the highest welding quality and applicable industry standards listed.

With seven qualified overhead crane inspectors with crane tech certifications, and three with NCCCO certifications for overhead crane and hoist inspectors, Garco WEMCO JV is well qualified to balance delivering a high-quality product and overcoming any unanticipated issues that may arise during the design, manufacturing or installation phases.



## US Army Corps of Engineers.

### RELEVANT TEAM MEMBERS:

- Juston Rouse, Installation Supervisor
- Matt Turner, Project Manager
- TJ Shields, PM and On-Site CQCM
- Jake Culley, Engineering Manager
- Nick Creel, Removal Work Site Superintendent (Garco)
- Jacob Culley, Mechanical DOR
- James Beckley, Superintendent
- Tyler Shields, CQCM
- Justin Almeida, Lead Service Tech
- Matt Humphrey, NCCCO Crane Inspector

Garco WEMCO JV possesses extensive experience with the removal and installation of a wide variety of type and size of cranes. While this project was awarded before the formation of our Joint Venture, Garco supplied one of its project managers and ironworker general foreman to supervise, plan and schedule the coordinated removal and re-installation of the cranes at the Oahe Dam. This scope of work was performed under a critical subcontract that included the required jacking and rigging services, site supervision, and essential plans for safety. Removal work was completed with careful consideration for the integrity of the cranes. To achieve this removal and re-installation, we used an innovative system consisting of four hydraulic jacks operated on a track system with a bridge and a rotator that can spin the girders out of the way of the rails. The trolleys were taken down by jacking them up and splitting the end ties on the bridge beams then rolling them apart. This allowed for the necessary space to lower the trolleys between the crane girders and safely use the second crane in the powerhouse to load the complete hoist trolleys out onto trucks for transport to WEMCO's facility.

The exact process above in a reversed sequence was used to put the first crane back into service in 2020. Once the crane was in the air and on the rails, we completed the required field wiring and ran the crane through the startup and commissioning, followed by final testing. Crane number two was returned to Oahe Dam for install and final testing in June of 2021.



### OWNER CONTACT

Cody Nickolas, Contracting Officer's Representative (COR)  
United States Army Corps of Engineers  
p: 605.945.3414 e: Cody.J.Nickolas@usace.army.mil

# BOEING FREDERICKSON CRANE 36 REHAB



📍 Puyallup, WA

✂ Firm Role: Design-Builder

📣 Delivery Method: Design-Build

## CONTRACT NUMBER:

7001249872

**START DATE:** 8/31/22

## SUBSTANTIAL COMPLETION:

2/24/23

## ORIGINAL ESTIMATE:

\$443,876

## FINAL CONTRACT VALUE:

\$664,174

**CAPACITY (IN TONS):** N/A

**SPAN (IN FEET):** N/A

## PROJECT RELEVANCY:



New Component Design  
& Install



Active Occupied Facility

## RELEVANT TEAM MEMBERS:

- Juston Rouse, Project Executive Technical
- Matt Turner, Project Executive Finance
- TJ Shields, Project Manager
- Matt Humphrey, Technical Service Lead/Inspector
- Charles Newton, EIT Lead Designer
- Jacob Culley, DOR (Mechanical)
- Russell Kolar, EIT
- Josh Morris, Field Service Lead/Inspector
- John Sanborn, Controls Engineer
- Tim Olson, DOR (Structural)



## PROJECT SUMMARY

WEMCO designed six new sets of end trucks of all various sizes for a custom crane inside a tankline. The installation had to be performed on top of a mezzanine with limited floor loading capacity and the work had to be completed without interrupting day-to-day production. WEMCO self-performed all design, fabrication, CNC machining, installation and commissioning.

WEMCO self-performed 100% of the design and engineering, manufacturing, testing, and commissioning; including manufacturing UL508 panels in our own shop. All hoists were designed and manufactured completely at WEMCO's facility. 75% of contract value of the installation of cranes and hoists on rails was self-performed. A rigging company was utilized to perform the lifting of cranes into position on rails and dropping of old equipment to the floor.



## OWNER CONTACT

Dave Dotson, Project Engineer, Boeing  
p: 253.315.4354 e: david.g.dotson@boeing.com



509.244.4773  
juston@wemcoinc.com



#### PROFESSIONAL EXPERIENCE

- 21 years in A/E/C Industry
- 18 years at WEMCO



#### CERTIFICATES & TRAINING

- First Aid & CPR
- CQM-C
- CraneTech Overhead Crane & Hoist Operator
- CraneTech Overhead Crane & Hoist Inspector
- NCCCO Certified Crane Inspector, Certification #1503108972R
- NCCCO Certified Crane Operator, Certification #1503108972R
- NCCCO Alternate Commissioner
- Forklift Operator Certificate
- Aerial Lift Operator Certificate

## JUSTON ROUSE

PRE-CONSTRUCTION PROJECT MANAGER/CQC/  
INSPECTOR | WEMCO

Juston began his career with WEMCO in 2006. Working throughout the shop and as a service tech provided him with an unmatched level of technical knowledge. After gaining experience in each department, he became a pivotal piece of the management team. Juston's hands on approach ensures that every project is completed with professional oversight and unwavering standards. He is experienced in each phase of product realization including risk management, budgeting, project management and manufacturing. He is an expert in field of overhead bridge cranes. Juston sits on the CMAA Crane Manufacturers Mechanical Engineering Committee, he is an NCCCO Certified Crane Inspector, Operator, and Alternate NCCCO Commissioner.



#### RELEVANT PROJECT EXPERIENCE

##### **DALLES DAM: 480-TON EMERGENCY INTAKE GANTRY CRANE REPLACEMENT**

THE DALLES, OR

**\$12.1M | Design-Build | Anticipated Completion 2024**

**Role:** Program Manager

**Contact:** Griffin Johnson, COR, USACE, Portland District

**p:** 541.952.9261 **e:** Griffin.W.Johnson@usace.army.mil

##### **GARCO CONSTRUCTION: FARWEST STEEL BRIDGE CRANES FOR NEW FACILITY (4)**

POST FALLS, ID

**\$1.7M | Design-Build | Completion 12/2023**

**Role:** Project Executive

**Contact:** Sean LaRue, Project Manager, Garco Construction

**p:** 509.535.4688 **e:** slarue@garco.com

##### **OAHE DAM: (2) 250-TON POWERHOUSE CRANES REHABILITATION**

FORT PIERRE, SD

**\$8.1M | Design-Build | Completion 02/2022**

**Role:** Installation Supervisor

**Contact:** Cody Nickolas, COR, USACE, Omaha District

**p:** 605.945.3414 **e:** Cody.J.Nickolas@usace.army.mil

##### **LIBBY DAM: 300-TON POWERHOUSE GANTRY CRANE REHAB**

LIBBY, MT

**\$6.1M | Design-Build | Completion 02/2022**

**Role:** Project Executive

**Contact:** Bradley Brandt, COR, USACE,

**p:** 509.979.8093 **e:** Bradley.R.Brandt@usace.army.mil

##### **LUCKY PEAK DAM: NEW 200-TON EMERGENCY GATE HOISTS**

BOISE, ID

**\$3.8M | Design-Build | Completion 12/2020**

**Role:** Program Manager

**Contact:** Nathan Pierson, COR, USACE

**p:** 208.954.9570 **e:** Nathan.R.Pierson@usace.army.mil

##### **FORT RANDALL DAM: (2) 155-TON SPAN POWERHOUSE CRANE REHABILITATION**

PICKSTOWN, SD

**\$3.8M | Design-Build | Completion 09/2017**

**Role:** CQC/Installation Supervisor

**Contact:** Todd Kjellse, Project CQC, USACE

**p:** 605.469.0880 **e:** todd.l.kjellsen@usace.army.mil



509.244.4773

mturner@wemcoinc.com



### PROFESSIONAL EXPERIENCE

- 12 years in A/E/C Industry
- 10 years at WEMCO



### EDUCATION

- Master's Degree - Business Administration, Whitworth University
- Bachelor's Degree - Operations & Supply Chain Management, Gonzaga University



### CERTIFICATES & TRAINING

- First Aid & CPR
- CQM-C
- NCCCO Certified Crane Inspector
  - License #1503108973R
  - Exp 3/31/2025
- CraneTech Certified Overhead Crane & Hoist Operator
- CraneTech Certified Overhead Crane & Hoist Inspector
- Forklift Operator Certification
- Aerial Lift Operator Certification
- Primavera P6

# MATT D. TURNER

CONSTRUCTION-SR. PROJECT MANAGER/CQC/VP | WEMCO

Matt has extensive experience in project and operations management in the industries serving cranes and lifting systems, material handling, aerospace, heavy hydraulics, machine tools industrial equipment, and oil and gas. He has successfully executed contracts with design-build project requirements for clients including the US Army Corps of Engineers, Boeing, Google, and other Public Works agencies. Matt has earned his success in managing high-risk projects with demanding deliverables requiring a higher level of budget control, contract management ability, risk assessment, and technical specification conformance.



### RELEVANT PROJECT EXPERIENCE

#### HOWARD HANSEN DAM: 45-TON GATE HOIST

RAVENSDALE, WA

**\$1.3M | Design-Build | Completion 04/2024**

**Role:** Project Manager

**Contact:** Torrey Crossman, Project Manager, BCI Construction

**p:** 802.309.3764 **e:** tcrossman@bciconusa.com

#### JOHN DAY DAM: NEW 20-TON TRASH RAKE GANTRY CRANE

JOHN DAY, OR

**\$3.7M | Design-Build | Completion 07/2022**

**Role:** Project Manager

**Contact:** Austin Breeden, Project Manager, Knight Construction

**p:** 509.990.8515 **e:** AustinB@knightconst.com

#### LIBBY DAM: 300-TON POWERHOUSE GANTRY CRANE REHABILITATION

LIBBY, MT

**\$6.1M | Design-Build | Completion 02/2022**

**Role:** Program Manager

**Contact:** Bradley Brandt, Contracting Officer's Rep., (COR), USACE

**p:** 509.979.8093 **e:** Bradley.R.Brandt@usace.army.mil

#### OAHE DAM: (2) 250-TON POWERHOUSE CRANES REHABILITATION

FORT PIERRE, SD

**\$8.1M | Design-Build | Completion 02/2022**

**Role:** Project Manager

**Contact:** Cody Nickolas, Contracting Officer's Rep., (COR), USACE

**p:** 605.945.3414 **e:** Cody.J.Nickolas@usace.army.mil

#### LUCKY PEAK DAM: NEW 200-TON EMERGENCY GATE HOISTS

BOISE, ID

**\$3.8M | Design-Build | Completion 12/2020**

**Role:** Project Manager

**Contact:** Nathan Pierson, Contracting Officer's Rep., COR, USACE

**p:** 208.954.9570 **e:** Nathan.R.Pierson@usace.army.mil

#### USACE FORT RANDALL DAM: (2) 155-TON SPAN POWERHOUSE CRANE REHABILITATION

PICKSTOWN, SD

**\$3.8M | Design-Build | Completion 09/2017**

**Role:** Project Manager

**Contact:** Todd Kjellse, Project CQC, USACE

**p:** 605.469.0880 **e:** todd.l.kjellsen@usace.army.mil





509.244.4773

tshields@wemcoinc.com



#### PROFESSIONAL EXPERIENCE

- 12 years in A/E/C Industry
- 12 years at WEMCO



#### CERTIFICATES & TRAINING

- First Aid & CPR
- CQM-C
- CraneTech Overhead Crane & Hoist Operator Certification
- CraneTech Overhead Crane & Hoist Inspector Certification
- Forklift Operator Cert
- Aerial Lift Operator Cert

## TYLER J. SHIELDS

PRE-CONSTRUCTION PROJECT MANAGER/QC | WEMCO

Mr. Shields came to WEMCO as a shop hand in 2011 and has learned the business from the shop floor up. He has proven to be not only a great leader, but an excellent Project Manager, Site Foreman, and CQC Manager. Tyler was first promoted to purchasing manager where he excelled. When working as the purchasing manager, Tyler began managing small projects throughout the shop. His customer satisfaction and on time delivery ratings were outstanding and because of his hard work, understanding of our supply chain, and dedication to customers, he was promoted to a full-time project manager in 2014. Tyler regularly fills the role of project foreman during the installation phases of work on many WEMCO projects and has also held the position of CQC Manager for USACE projects.



#### RELEVANT PROJECT EXPERIENCE

##### **BOEING: 17-07 BRIDGE & HOIST CARRIER REPLACEMENT**

AUBURN, WA

**\$2M | Design-Build | Completion 11/2023**

**Role:** Project Manager

**Contact:** Rajesh Bangdiwala, Project Manager

**p:** 919.602.4096 **e:** Rajesh.S.Bangdiwala@boeing.com

##### **OAHE DAM: (2) 250-TON POWERHOUSE CRANES REHABILITATION**

FORT PIERRE, SD

**\$8.1M | Design-Build | Completed 02/2022**

**Role:** Project Foreman/Assistant Project Manager

**Contact:** Cody Nickolas, COR, USACE, Omaha District

**p:** 605.945.3414 **e:** Cody.J.Nickolas@usace.army.mil

##### **BLUE ORIGIN: 625-TON ACTUATING HYDRAULIC TEST PRESS**

MERRIT ISLAND, FL

**\$1M | Design-Build | Completion 03/2020**

**Role:** Project Manager

**Contact:** Haley Brodecki, Project Manager

**p:** 360.840.7943 **e:** hbrodecki@blueorigin.com

##### **FORT RANDALL DAM: (2) 155-TON POWERHOUSE CRANE REHABILITATION**

PICKSTOWN, SD

**\$3.8M | Design-Build | Completed 09/2017**

**Role:** Project Foreman

**Contact:** Todd Kjellse, Project CQC, USACE, Omaha District

**p:** 605.469.0880 **e:** todd.l.kjellsen@usace.army.mil

##### **BOEING STATIC TEST CRANE: 5-TON UHSG, 286'-6" SPAN**

EVERETT, WA

**\$3.1M | Design-Build | Completed 12/2016**

**Role:** Project Foreman

**Contact:** Graham Bennett, Engineer, Boeing Site Services

**p:** 425.220.8431 **e:** graham.bennett@boeing.com

##### **SEAPORT STEEL: (2) 15-TON & (2) 25-TON BRIDGE CRANES**

AIRWAY HEIGHTS, WA

**\$1.1M | Design-Build | Completed 01/2015**

**Role:** Project Manager/Project Foreman

**Contact:** Galen Hyatt, Site Supervisor

**p:** 509.244.5482 **e:** galenh@seaportsteel.com



509.244.4773  
mhumphrey@wemcoinc.com



#### PROFESSIONAL EXPERIENCE

- 19 years in A/E/C Industry
- 12 years at WEMCO
- Over 20,000 Hours of Crane Inspection & Maintenance



#### EDUCATION

- Spokane Community College - Diesel & Heavy Duty Equipment AAS - 2005



#### CERTIFICATES & TRAINING

- NDT Electromagnetic Wire Rope Inspector - 2021
- Harrington Crane & Hoist Service Academy - 2023
- MSHA Surface & Underground Mine Safety Certification - 2023
- CraneTech Certified Overhead Crane & Hoist Operator - 2023
- NCCCO Certified Overhead Crane & Hoist Inspector - 2023  
NCCCO #2003190953, Exp. 3/2025



# MATT HUMPHREY

SERVICE & INSPECTION MANAGER | WEMCO

Matt's experience includes installation, testing, and inspection of bridge, gantry, and jib cranes and other specialized lifting equipment with a range of capacities from 500 pounds to 450 tons. As the lead service & inspection technician for customers like BNSF, Avista, and Boeing, Matt is requested by name for emergency troubleshooting and repairs, maintenance and upgrade recommendations, and on-site training of facility staff. He has installed and inspected over 500 cranes during his career and is a technical specialist for numerous crane and hoist brands including Whiting, CMCO, Yale, Stahl, Harrington, Gorbel and WEMCO.



#### RELEVANT PROJECT EXPERIENCE

##### THE BOEING COMPANY: 17-06 BLDG BRIDGE CRANE WITH 5 AUTOMATED HOIST RAILS

AUBURN, WA

\$9.8M | Design-Build | Completion 01/2024

Role: Installation, Commissioning, & Load Test Technician

Contact: Rajesh Bangdiwala, Project Manager, Boeing

p: 919.602.4096 e: rajesh.s.bangdiwala@boeing.com

##### GARCO CONSTRUCTION: FARWEST STEEL BRIDGE CRANES FOR NEW FACILITY (4)

POST FALLS, ID

\$1.7M | Design-Build | Completion 12/2023

Role: Installation, Commissioning, & Load Test Technician

Contact: Sean LaRue, Project Manager, Garco Construction

p: 509.535.4688 e: slarue@garco.com

##### STOKE SPACE TECHNOLOGIES: 10-TON GANTRY CRANES (2) 20-TON GANTRY CRANES (2)

KENT, WA

\$1.01M | Design-Build | Completion 10/2023

Role: Installation Technician

Contact: Gene Kraft, Principal Manufacturing Engineer, Stoke Space

p: 432.207.0902 e: gkraft@stokespace.com

##### HECLA LUCKY FRIDAY MINE: 15-TON MONORAIL HOIST & RUNWAY

MULLAN, ID

\$90K | Design-Build | Completion 07/2023

Role: Installation, Commissioning, & Load Test Technician

Contact: Tim Felzian, Project Manager, Hecla Limited

p: 208.744.1846 e: tfelzian@hecla-mining.com

##### LIBBY DAM: 300-TON POWERHOUSE GANTRY CRANE REHAB

LIBBY, MT

\$6.1M | Design-Build | Completion 02/2022

Role: Inspection Manager, Technical Lead for in-process testing

Contact: Bradley Brandt, Contracting Officer's Representative (COR), USACE

p: 509.979.8093 e: Bradley.R.Brandt@usace.army.mil

##### OAHE DAM: (2) 250-TON POWERHOUSE CRANES REHAB

FORT PIERRE, SD

\$8.1M | Design-Build | Completion 02/2022

Role: Inspection Manager, Technical Lead

Contact: Cody Nickolas, Contracting Officer's Representative (COR), USACE



509.244.4773  
nrosenoff@wemcoinc.com



#### PROFESSIONAL EXPERIENCE

- 20 Years in Heavy Equipment
- 4 years at WEMCO
- 8,000+ Hours of Crane Inspection & Maintenance



#### EDUCATION

- Spokane Community College - Diesel & Heavy Duty Equipment AAS - 2002



#### CERTIFICATES & TRAINING

- Class A Commercial Driver's License
- NDT Electromagnetic Wire Rope Inspector - 2021
- Harrington Crane & Hoist Service Academy - 2021
- MSHA Surface & Underground Mine Safety Certification - 2023
- CraneTech Certified Overhead Crane & Hoist Operator - 2023
- CraneTech Certified Overhead Crane & Hoist Inspector - 2023
- CPR, First Aid, CPR Certified
- Forklift & Aerial Lift Certified

# NICK ROSENOFF

FIELD SERVICE TECHNICIAN | WEMCO

Mr. Rosenoff began working on industrial equipment as a young boy on his parent's farm. After graduating from high school, he went on to obtain a degree in diesel & heavy equipment mechanics. His extensive experience puts him at the forefront of our field service department where he is responsible for inspecting, testing, and maintaining cranes for nearly 150 customers. Mr. Rosenoff is also an integral part of our installation team, ensuring that each project meets the CMAA Standards.



#### RELEVANT PROJECT EXPERIENCE

##### THORPE-ABBOTT PROPERTIES: (2) 100-TON BRIDGE CRANES ANNUAL INSPECTIONS

SPOKANE, WA

T&M | Completed Annually 2020-2023

Role: Crane & Hoist Inspector, Maintenance Technician

Contact: Christopher Dibble, Warehouse Manager

p: 509.244.4773 e: cdibble@wemcoinc.com

##### GARCO CONSTRUCTION: (4) FARWEST STEEL BRIDGE CRANES FOR NEW FACILITY

POST FALLS, ID

\$1.7M | Design-Build | Completion 12/2023

Role: Installation & Commissioning Technician

Contact: Sean LaRue, Project Manager, Garco Construction

p: 509.535.4688 e: slarue@garco.com

##### HECLA LUCKY FRIDAY MINE: 30-TON BRIDGE CRANE & 5-TON MONORAIL

MULLAN, ID

\$328K | Design-Build | Completion 07/2023

Role: Installation, Commissioning, & Load Test Technician

Contact: Doug Bayer, Project Manager, Hecla Limited

p: 208.744.1846 e: dbayer@hecla-mining.com

##### OAHE DAM: (2) 250-TON POWERHOUSE CRANES REHABILITATION

FORT PIERRE, SD

\$8.1M | Design-Build | W9128F18C0002 | Completion 02/2022

Role: Installation & Commissioning Technician

Contact: Cody Nickolas, COR, USACE, Omaha District

p: 605.945.3414 e: Cody.J.Nickolas@usace.army.mil

#### PREVIOUS WORK EXPERIENCE

##### WM WINKLER COMPANY, EQUIPMENT MECHANIC

SPOKANE, WA 2003-2005, 2014-2020

Role: Equipment Mechanic, Maintenance Manager

Contact: Brian Winkler, Owner, Winkler Construction

p: 509.489.6100 e: brian@wmwinkler.com

##### SHAMROCK PAVING, EQUIPMENT MECHANIC

SPOKANE, WA 2005-2014

Role: Equipment Mechanic, Maintenance Manager

Contact: Kerry Strehlou, Equipment Manager

p: 509.999.5597



509.844.8018  
jbeckley@wemcoinc.com



#### PROFESSIONAL EXPERIENCE

- 14 years in A/E/C Industry
- 4 years at WEMCO



#### EDUCATION

- 5 year, 8000 hour Apprenticeship - Journeyman Ironworker, June 2007
- Local 14 Apprenticeship, Spokane



#### CERTIFICATES & TRAINING

- OSHA 10
- OSHA 30
- First Aid & CPR
- Lead Hazard
- Forklift Safety
- Scaffold User
- Steel Erection Safety
- Boom Truck Training
- Scaffold Erector/Dismantler
- Ironworker's National WCP
- Qualified Rigger and Signal Person
- W-FCAW Seismic/E7IT-8/Copper
- NDT Trained for Electromagnetic Inspection of Wire Ropes
- Portable Line Boring Certificate

# JAMES BECKLEY

SITE SUPERINTENDENT | WEMCO

James Beckley has spent most of his career in field leadership roles and is known for his ability maintain a safe job site and deliver a quality product. As an expert rigger, he is detail oriented and can effectively lead teams through rigging of complex loads.

As project superintendent, James is responsible for safety, supervision, and coordination of all daily construction activities on the job site. He also manages logistics to ensure proper transportation, delivery, and staging of all materials and equipment. James will ensure a smooth and uniform work flow in compliance with construction documents, contract requirements, safety, security, and environmental concerns.



#### RELEVANT PROJECT EXPERIENCE

##### **BOEING: 17-07 BRIDGE & HOIST CARRIER REPLACEMENT**

AUBURN, WA

**\$2M | Design-Build | Completion 11/2023**

**Role:** Installation Foreman, Site Superintendent

**Contact:** Rajesh Bangdiwala, Project Manager

**p:** 919.602.4096 **e:** Rajesh.S.Bangdiwala@boeing.com

##### **OAHE DAM: (2) 250-TON POWERHOUSE CRANES REHAB**

FORT PIERRE, SD

**\$8.1M | Design-Build | Completion 02/2022**

**Role:** SSHO and Installation Supervisor Alternate

**Contact:** Cody Nickolas, Contracting Officer's Rep., (COR), USACE

**p:** 605.945.3414 **e:** Cody.J.Nickolas@usace.army.mil

##### **LUCKY PEAK DAM: NEW 200-TON EMERGENCY GATE HOISTS**

BOISE, ID

**\$3.8M | Design-Build | Completion 12/2020**

**Role:** Installation Supervisor

**Contact:** Nathan Pierson, Contracting Officer's Rep., (COR), USACE

**p:** 208.954.9570 **e:** nathan.r.pierson@usace.army.mil

#### PREVIOUS WORK EXPERIENCE

##### **PRECISION PRECAST ERECTORS**

POST FALLS, ID

**2019-2020 | Role:** Field Superintendent

**Responsibilities:** Plan grid tracking for rigging and welding activities, job cost reporting, and ensuring safety standards.

##### **NORDHOLM COMPANIES**

EVERETT, WA

**2016-2019 | Role:** Field Superintendent

**Responsibilities:** Job site supervision and coordination, team member training, materials and supply management, and site safety.

##### **AMERICAN IRONWORKERS & ERECTORS**

SPOKANE, WA

**2009-2016 | Role:** Field Superintendent

**Responsibilities:** Team coordination and scheduling, developing standard operating procedures, and ensuring safe work practices.



509.244.4773

jalmeida@wemcoinc.com



#### PROFESSIONAL EXPERIENCE

- 13 years in A/E/C Industry
- 11 years at WEMCO as a full-time Crane & Hoist Inspector/Installation Technician
- Over 20,000 of Crane Inspection and Maintenance



#### CERTIFICATES & TRAINING

- First Aid & CPR
- Forklift Operator Certification
- Aerial Lift Operator Certification
- NDT Electromagnetic Wire Rope Inspector
- CraneTech Certified Overhead Crane & Hoist Inspector
- CraneTech Certified Overhead Crane & Hoist Operator

Customers include: BNSF, Avista Utilities, Pacific Steel, USACE, Hecla Mine, City of Spokane, Schweitzer Engineering Laboratories, RW Fab, Inland Northwest Precast, Winkler Construction.

## JUSTIN "LJ" ALMEIDA

CRANE & HOIST INSPECTOR, INSTALL TECH | WEMCO

Justin has been with WEMCO for over 11 years and has assembled, wired, installed, and tested hundreds of cranes and material handling devices with a range of capacities from 500 pounds to 300 tons. He has extensive electrical expertise and experience with a wide range of hoist brands including CMCO, Yale, Stahl, Harrington, Gobel and WEMCO. His excellence in workmanship has been repeatedly recognized by customers who have given him the highest marks on customer feedback cards, CPARS, and references.



#### RELEVANT PROJECT EXPERIENCE

##### BECHTEL NATIONAL: CRANE INSPECTION AND REPAIRS

RICHLAND, WA

\$106K | Service & Inspection | Completion 03/2024

Role: Lead Inspector

Contact: Sue Harp, AR, BNI

p: 509.827.4429 e: csharp@bechtel.us

##### THORPE-ABBOTT PROPERTIES: (2) 100-TON BRIDGE CRANES ANNUAL INSPECTIONS

SPOKANE, WA

T&M | Completed Annually | 2015, 2018-2022

Role: Crane & Hoist Inspector, Maintenance Technician

Contact: Christopher Dibble, Warehouse Manager

p: 509.244.4773 e: cdibble@wemcoinc.com

##### LIBBY DAM: 300-TON POWERHOUSE GANTRY CRANE REHAB

LIBBY, MT

\$6.1M | Design-Build | W9128F19D0023 | Completion 02/2022

Role: Installation Technician, Crane & Hoist Inspector

Contact: Bradley Brandt, Contracting Officer's Representative (COR), USACE

p: 509.979.8093 e: Bradley.R.Brandt@usace.army.mil

##### OAHE DAM: (2) 250-TON POWERHOUSE CRANES REHAB

FORT PIERRE, SD

\$8.1M | Design-Build | W9128F18C0002 | Completion 02/2022

Role: Assistant Crane & Hoist Inspector, Load Test Operator

Contact: Cody Nickolas, Contracting Officer's Representative (COR), USACE

p: 605.945.3414 e: Cody.J.Nickolas@usace.army.mil

##### LUCKY PEAK DAM: NEW 200-TON EMERGENCY GATE HOISTS

BOISE, ID

\$3.8M | Design-Build | W912EF19D0023 | Completion 12/2020

Role: Installation Technician, Crane & Hoist Inspector

Contact: Nathan Pierson, COR, USACE

p: 208.954.9570 e: Nathan.R.Pierson@usace.army.mil

##### FORT RANDALL DAM: (2) 155-TON SPAN POWERHOUSE CRANE REHABILITATION

PICKSTOWN, SD

\$3.8M | Design-Build | W9128F15C0008 | Completion 09/2017

Role: Installation Technician, Assistant Crane & Hoist Inspector

Contact: Todd Kjellse, Project CQC, USACE

p: 605.469.0880 e: todd.l.kjellsen@usace.army.mil



509.244.4773  
jculley@wemcoinc.com

### PROFESSIONAL EXPERIENCE

- 20 years in A/E/C Industry
- Licensed PE in WA State

### EDUCATION

- Gonzaga University- Bachelor of Science Mechanical Engineering, 2002

### CERTIFICATES & TRAINING

- Registered Professional Engineer, 2011
- First Aid & CPR Certified
- CQM-C

# JACOB CULLEY

DESIGNER OF RECORD/MECHANICAL  
ENGINEER, P.E. | WEMCO

Jacob has over 20 years of progressive engineering experience with a broad mix of mid to large scale material handling and processing projects for the mining, hydroelectric, and agricultural industries as well as new product development activities in the construction and secondary packaging sectors. The breadth of his experience includes early stage system development, system level design/integration, and component level detailed design. In addition to his design experience, he has experience in project site activities including site erection, startup, and commissioning.

### RELEVANT PROJECT EXPERIENCE

#### BONNEVILLE DAM: 65-TON TAILRACE GANTRY CRANE

BONNEVILLE, OR

\$6.37M | Design-Build | Anticipated Completion 03/2026

Role: Mechanical Designer of Record

Contact: Griffin Johnson, COR, USACE, Portland District

p: 541.952.9261 e: Griffin.W.Johnson@usace.army.mil

#### MCNARY DAM: NAVIGATION LOCK CRANE #2 REPLACEMENT

UMATILLA, OR

\$10.28M | Design-Build | Anticipated Completion 10/2025

Role: Mechanical Designer of Record, DQC Manager

Contact: Rebekah Sheridan, COR, USACE, Walla Walla District

p: 509.818.2520 e: Rebekah.A.Sheridan@usace.army.mil

#### MCNARY DAM: NAVIGATION LOCK CRANE #1 REPLACEMENT

UMATILLA, OR

\$8.43M | Design-Build | Anticipated Completion 10/2024

Role: Mechanical Designer of Record, DQC Manager

Contact: Rebekah Sheridan, COR, USACE, Walla Walla District

p: 509.818.2520 e: Rebekah.A.Sheridan@usace.army.mil

#### THE DALLES DAM: 480-TON EMERGENCY INTAKE GANTRY CRANE REPLACEMENT

THE DALLES, OR

\$12.1M | Design-Build | Completion 01/2024

Role: DQC Manager

Contact: Griffin Johnson, COR, USACE, Portland District

p: 541.952.9261 e: Griffin.W.Johnson@usace.army.mil

#### LIBBY DAM: 300-TON POWERHOUSE GANTRY CRANE REHAB

LIBBY, MT

\$6.1M | Design-Build | Completion 03/2022

Role: Mechanical Designer of Record

Contact: Bradley Brandt, COR, USACE, Seattle District

p: 509.979.8093 e: Bradley.R.Brandt@usace.army.mil

#### LOWER GRANITE JFF GATE HOIST

LOWER GRANITE LAKE, WA

\$282K | Design-Build | Completion 12/2021

Role: Mechanical Designer of Record

Contact: Jeff Harper, Northbank Civil & Marine Inc.

p: 360.984.3336 e: JeffH@northbankcm.com



509.244.4773  
tolson@wemcoinc.com



#### PROFESSIONAL EXPERIENCE

- 12 years in A/E/C Industry
- Licensed PE in WA, ID, TX, ND, IN



#### EDUCATION

- Washington State University- B.S. & M.S. Civil & Structural Engineering, 2010



#### CERTIFICATES & TRAINING

- First Aid & CPR
- Registered Professional Engineer, 2014

## TIM OLSON

STRUCTURAL ENGINEER, P.E. | WEMCO

Mr. Olson is experienced with design and analysis of structures for numerous industries and uses. In 2011, he began his engineering career at Sarens USA, where he was responsible for design and engineering of gantry cranes, elevated runways, temporary structures, and rigging for heavy lifts. He has experience with installations, removals, and specialized transports of payloads weighing up to 600 tons.



#### RELEVANT PROJECT EXPERIENCE

##### **BONNEVILLE DAM: 65-TON TAILRACE GANTRY CRANE**

BONNEVILLE, OR

**\$6.37M | Design-Build | Anticipated Completion 03/2026**

**Role:** Structural Designer of Record

**Contact:** Griffin Johnson, COR, USACE, Portland District

**p:** 541.952.9261 **e:** Griffin.W.Johnson@usace.army.mil

##### **MCNARY DAM: NAVIGATION LOCK CRANE #2 REPLACEMENT**

PLYMOUTH, WA

**\$8.2M | Design-Build | Anticipated Completion 10/2025**

**Role:** Structural Design & Analysis

**Contact:** Rebekah Sheridan, COR, USACE, Walla Walla District

**p:** 509.818.2520 **e:** Rebekah.A.Sheridan@usace.army.mil

##### **MCNARY DAM: NAVIGATION LOCK CRANE #1 REPLACEMENT**

UMATILLA, OR

**\$8.43M | Design-Build | Anticipated Completion 10/2024**

**Role:** Structural Design & Analysis

**Contact:** Rebekah Sheridan, COR, USACE, Walla Walla District

**p:** 509.818.2520 **e:** Rebekah.A.Sheridan@usace.army.mil

##### **PERTAMINA BALONGAN REFINERY REACTOR TURNABLE & TAILING FRAME DESIGN**

BALONAN, JAVA ISLAND, INDONESIA

**\$ N/D | Design-Build | Completion 02/2022**

**Role:** Structural Engineer of Record **Firm:** Lowther-Rolton LLC

**Contact:** Apriadi Bunda, Consortium of ETI, Yuhan Tech, PBAS

##### **NOVO TEMPO GENERATOR REPLACEMENT**

PORT OF ACU, BRAZIL

**\$ N/D | Design-Build | Completion 11/2021**

**Role:** Third Party Prof. Engineer Reviewer **Firm:** Lowther-Rolton LLC

**Contact:** Rick Brenner Siemens Energy **p:** +49 (911) 6505 6505

##### **GAINESVILLE POWER PLANT BUILDING ANALYSIS**

GAINESVILLE, FL

**\$3.8M | Design-Build | Completion 09/2021**

**Role:** Structural Engineer of Record **Firm:** Lowther-Rolton LLC

**Contact:** Rick Brenner, Siemens Energy **p:** +49 (911) 6505 6505

##### **COMANCHE PEAK NUCLEAR POWER PLANT STATOR REPLACEMENT PROJECT**

GLEN ROSE, TX

**\$ N/D | Firm Fixed Price | Completion 12/2018**

**Role:** Structural Engineer **Firm:** Lowther-Rolton LLC

**Contact:** Rick Brenner, Siemens Energy **p:** +49 (911) 6505 6505



509.244.4773

kharrison@wemcoinc.com



### PROFESSIONAL EXPERIENCE

- 21 years in A/E/C Industry
- Licensed PE in WA State



### EDUCATION

- Washington State University- B.S. Mechanical Engineering, Minor in Material Science, 2003



### CERTIFICATES & TRAINING

- Registered Professional Engineer, 2010
- USACE CQM-C, 2024
- AWS Certified Welding Engineer, 2018
- AWS Certified Welding Inspector, 2016
- AWS D1.1 Standard Welding of Structural Steel, 2005
- AWS Section IX Training, 2006
- ASME B&PV Code Training, 2010
- Practical Introduction to Finite Element Analysis, 2015
- Interactive Leadship, Bill Sweigert

# KYLE HARRISON

DESIGN WQCM/MECHANICAL ENGINEER, CWENG, CWI, P.E. | WEMCO

Mr. Harrison is a multifaceted professional adept in material science, welding inspections, welding processes, and project management. With a mastery over material properties and welding techniques, he ensures the integrity and quality of welded structures through meticulous inspections and expert guidance. His proficiency extends to project management, where he orchestrates seamless coordination between teams, ensuring projects are completed efficiently and to the highest standards.



### RELEVANT PROJECT EXPERIENCE

#### DALLES DAM: 480-TON EMERGENCY INTAKE GANTRY CRANE REPLACEMENT

THE DALLES, OR

\$12.1M | Design-Build | Anticipated Completion 2024

Role: Project Manager

Contact: Griffin Johnson, COR, USACE, Portland District

p: 541.952.9261 e: Griffin.W.Johnson@usace.army.mil

#### BULL SHOALS DAM: 170-TON BRIDGE CRANE REPLACEMENT

LAKEVIEW, AR

\$5.7M | Design-Build | Anticipated Completion 2026

Role: Project Manager

Contact: David Glorit, COR, USACE, Little Rock District

p: 501.324.5717 e: David.A.Glorit@usace.army.mil

#### GARRISON DAM: INTAKE BRIDGE AUXILIARY CRANE REHABILITATION

RIVERDALE, ND

\$1.79M | Design-Build | Anticipated Completion 2025

Role: Project Manager

Contact: Leeann Wimer, COR, USACE, Omaha District

p: 701.654.7714 e: Leeann.R.Wimer@usace.army.mil

#### ALBENI FALLS DAM: SPILLWAY GATE REPAIRS

OLDTOWN, ID

\$3.13M | Design-Build | Anticipated Completion 2025

Role: Welding Engineer

Contact: Katlyn Struxness, COR, USACE, Seattle District

p: 509-873-1361 e: Katlyn.T.Struxness@usace.army.mil

#### BECHTEL NATIONAL: CRANE INSPECTION AND REPAIRS

RICHLAND, WA

\$106K | Service & Inspection | Completion 03/2024

Role: Project Manager

Contact: Sue Harp, AR, BNI

p: 509.827.4429 e: csharp@bechtel.us

### PREVIOUS WORK EXPERIENCE

#### WAGSTAFF MANUFACTURING

SPOKANE, WA 2003-2021

Role: Manufacturing Engineering Manager, Welding Engineer

Contact: Courtney Johnson, Wagstaff Mfg.

p: 509.994.8094





509.244.4773

jsanborn@wemcoinc.com



#### PROFESSIONAL EXPERIENCE

- 20 years in A/E/C Industry
- 4 years at WEMCO



#### EDUCATION

- Spokane Community College - A.A.S. Fluid Power Technology, 1995
- Spokane Community College - A.A.S. Automation Specialist, 1996



#### CERTIFICATES & TRAINING

- UL508A Qualified Manufacturer Technical Representative
- UL508A Certification: Designing for Compliance in Industrial Control Panels
- Arc Flash Electrical Safety Training
- CraneTech Certified Overhead Crane & Hoist Operator
- CraneTech Certified Overhead Crane & Hoist Inspector

# JOHN SANBORN

CONTROLS ENGINEER | WEMCO

John's experience in machine controls and industrial automation adds extreme value to WEMCO's engineering and automation division. He has been involved in the design, programming, and commissioning of many customized industrial automation systems and complex crane and hoisting systems. His 20+ years of industry experience coupled with his drive for success, ensure the creation of high quality products in the most efficient manner possible.



#### RELEVANT PROJECT EXPERIENCE

##### **MCNARY DAM: 50-TON NAVIGATION LOCK DERRICK CRANE**

BENTON COUNTY, WA

**\$8.2M | Design-Build | Anticipated Completion 10/2024**

**Role:** Controls Engineer

**Contact:** Michael Timm, CQC, USACE

**p:** 541.922.1328 **e:** Michael.B.Timm@usace.army.mil

##### **BOEING: 17-07 BRIDGE & HOIST CARRIER REPLACEMENT**

AUBURN, WA

**\$2M | Design-Build | Completion 11/2023**

**Role:** Controls Engineer

**Contact:** Rajesh Bangdiwala, Project Manager

**p:** 919.602.4096 **e:** Rajesh.S.Bangdiwala@boeing.com

##### **JOHN DAY DAM: NEW 20-TON TRASH RAKE GANTRY CRANE**

JOHN DAY, OR

**\$3.7M | Design-Build | Completion 03/2022**

**Role:** Controls Engineer

**Contact:** Austin Breden, Project Manager, Knight Construction

**p:** 509.990.8515 **e:** AustinB@knightconst.com

##### **LIBBY DAM: 300-TON POWERHOUSE GANTRY CRANE REHABILITATION**

LIBBY, MT

**\$6.1M | Design-Build | Completion 02/2022**

**Role:** Controls Engineer, FAT Testing Support

**Contact:** Bradley Bandt, Contracting Officer's Representative (COR)

**p:** 509.979.8093 **e:** Bradley.R.Brandt@usace.army.mil

##### **BOEING: 18-41 SIL OVERHEAD CRANE SYSTEM**

KENT, WA

**\$450K | Design-Build | Completion 12/2020**

**Role:** Controls Engineer

**Contact:** Ross Liston, Project Manager, Schuchart

**p:** 206.682.3030 **e:** ross.liston@schuchart.com

##### **CENTRAL NEBRASKA WOOD PRODUCTS: AUTOMATED PLYWOOD & DIMENSIONAL LUMBER HANDLING MACHINES**

SUTTON, NE

**Design-Build | Completion 02/2019**

**Role:** Controls Engineer

**Contact:** Kurt Andres, General Manager

**p:** 402.773.4319 **e:** kurt@nebraskawood.com



509.244.4773  
cnewton@wemcoinc.com



#### PROFESSIONAL EXPERIENCE

- 10 years in A/E/C Industry
- 10 years at WEMCO



#### EDUCATION

- Eastern Washington University - B.S. Mechanical Engineering, 2014



#### CERTIFICATES & TRAINING

- CQM-C, 2021
- Crane Manufacturers Association of America (CMAA) Mechanical Sub-Committee Chairman
- Crane Manufacturers Association of America (CMAA) Qualified Engineering Delegate
- First Aid & CPR

## CHARLES D. NEWTON

MECHANICAL ENGINEER | WEMCO

Mr. Newton's design experience has involved a vast variety of electro-mechanical projects ranging from cranes to full automated machinery. WEMCO's environment of quickly designing and building quality products has quickly expanded his knowledge of cranes and given him the opportunity to work on cranes with features such as polar rotating trolleys and a range of capacities from 1000 lbs to 450-tons.



#### RELEVANT PROJECT EXPERIENCE

##### HOWARD HANSEN DAM: 45-TON GATE HOIST

RAVENSDALE, WA

**\$1.3M | Design-Build | Completed 04/2024**

**Role:** Mechanical Engineer

**Contact:** Torrey Crossman, Project Manager, BCI Construction

**p:** 802.309.3764 **e:** tcrossman@bciconusa.com

##### JOHN DAY DAM: NEW 20-TON TRASH RAKE GANTRY CRANE

JOHN DAY, OR

**\$3.7M | Design-Build | Completed 03/2022**

**Role:** Mechanical Engineer

**Contact:** Austin Breeden, Project Manager, Knight Construction

**p:** 509.990.8515 **e:** AustinB@knightconst.com

##### OAHE DAM: (2) 250-TON POWERHOUSE CRANES REHABILITATION

FORT PIERRE, SD

**\$8.1M | Design-Build | Completed 02/2022**

**Role:** Mechanical Engineer

**Contact:** Cody Nickolas, COR, USACE, Omaha District

**p:** 605.945.3414 **e:** Cody.J.Nickolas@usace.army.mil

##### FORT RANDALL DAM: (2) 155-TON POWERHOUSE CRANE REHABILITATION

PICKSTOWN, SD

**\$3.8M | Design-Build | Completed 09/2017**

**Role:** Mechanical Engineer

**Contact:** Todd Kjellse, Project CQC, USACE

**p:** 605.469.0880 **e:** todd.l.kjellsen@usace.army.mil

##### THE BOEING COMPANY: 5-TON STATIC TEST CRANE

EVERETT, WA

**\$3.1M | Design-Build | Completed 12/2016**

**Role:** Mechanical Engineer

**Contact:** Graham Bennett, Engineer, Boeing Site Services

**p:** 425.220.8431 **e:** graham.bennett@boeing.com

##### SEAPORT STEEL: (2) 15-TON & (2) 25-TON BRIDGE CRANES

AIRWAY HEIGHTS, WA

**\$1.1M | Design-Build | Completed 01/2015**

**Role:** Mechanical Engineer

**Contact:** Galen Hyatt, Site Supervisor

**p:** 509.244.5482 **e:** galenh@seaportsteel.com

# Summary of Work-Related Injuries and Illnesses



All establishments covered by Part 1904 must complete this Summary page, even if no work-related injuries or illnesses occurred during the year. Remember to review the Log to verify that the entries are complete and accurate before completing this summary.

Using the Log, count the individual entries you made for each category. Then write the totals below, making sure you've added the entries from every page of the Log. If you had no cases, write "0."

Employees, former employees, and their representatives have the right to review the OSHA Form 300 in its entirety. They also have limited access to the OSHA Form 301 or its equivalent. See 29 CFR Part 1904.35, in OSHA's recordkeeping rule, for further details on the access provisions for these forms.

### Number of Cases

Total number of deaths	Total number of cases with days away from work	Total number of cases with job transfer or restriction	Total number of other recordable cases
<u>0</u>	<u>0</u>	<u>0</u>	<u>3</u>
(G)	(H)	(I)	(J)

### Number of Days

Total number of days away from work	Total number of days of job transfer or restriction
<u>0</u>	<u>0</u>
(K)	(L)

### Injury and Illness Types

Total number of . . . (M)			
(1) Injuries	<u>3</u>	(4) Poisonings	<u>0</u>
(2) Skin disorders	<u>0</u>	(5) Hearing loss	<u>0</u>
(3) Respiratory conditions	<u>0</u>	(6) All other illnesses	<u>0</u>

Post this Summary page from February 1 to April 30 of the year following the year covered by the form.

Public reporting burden for this collection of information is estimated to average 58 minutes per response, including time to review the instructions, search and gather the data needed, and complete and review the collection of information. Persons are not required to respond to the collection of information unless it displays a currently valid OMB control number. If you have any comments about these estimates or any other aspects of this data collection, contact: US Department of Labor, OSHA Office of Statistical Analysis, Room N-3644, 200 Constitution Avenue, NW, Washington, DC 20210. Do not send the completed forms to this office.

### Establishment information

Your establishment name WEMCO, Inc.  
 Street 5610 W. Thorpe Rd.  
 City Spokane State WA ZIP 99224

Industry description (e.g., Manufacture of motor truck trailers)

Manufacturing

Standard Industrial Classification (SIC), if known (e.g., 3715)

OR

North American Industrial Classification (NAICS), if known (e.g., 336212)

333517

**Employment information** (If you don't have these figures, see the Worksheet on the back of this page to estimate.)

Annual average number of employees

85

Total hours worked by all employees last year

171,951

**Sign here**

Knowingly falsifying this document may result in a fine.

I certify that I have examined this document and that to the best of my knowledge the entries are true, accurate, and complete.

Karma R. Rourke President

Company executive

509 244-4773

Phone

Title

01/25/2022

Date

# Summary of Work-Related Injuries and Illnesses

Year 2022



U.S. Department of Labor  
Occupational Safety and Health Administration

Form approved OMB no. 1218-0176

All establishments covered by Part 1904 must complete this Summary page, even if no work-related injuries or illnesses occurred during the year. Remember to review the Log to verify that the entries are complete and accurate before completing this summary.

Using the Log, count the individual entries you made for each category. Then write the totals below, making sure you've added the entries from every page of the Log. If you had no cases, write "0."

Employees, former employees, and their representatives have the right to review the OSHA Form 300 in its entirety. They also have limited access to the OSHA Form 301 or its equivalent. See 29 CFR Part 1904.35, in OSHA's recordkeeping rule, for further details on the access provisions for these forms.

### Number of Cases

Total number of deaths	Total number of cases with days away from work	Total number of cases with job transfer or restriction	Total number of other recordable cases
<u>0</u>	<u>0</u>	<u>3</u>	<u>2</u>
(G)	(H)	(I)	(J)

### Number of Days

Total number of days away from work	Total number of days of job transfer or restriction
<u>0</u>	<u>183</u>
(K)	(L)

### Injury and Illness Types

Total number of . . . (M)	
(1) Injuries	<u>5</u>
(2) Skin disorders	<u>0</u>
(3) Respiratory conditions	<u>0</u>
(4) Poisonings	<u>0</u>
(5) Hearing loss	<u>0</u>
(6) All other illnesses	<u>0</u>

Post this Summary page from February 1 to April 30 of the year following the year covered by the form.

Public reporting burden for this collection of information is estimated to average 50 minutes per response, including time to review the instructions, search and gather the data needed, and complete and review the collection of information. Persons are not required to respond to the collection of information unless it displays a currently valid OMB control number. If you have any comments about these estimates or any other aspects of this data collection, contact: US Department of Labor, OSHA Office of Statistical Analysis, Room N-3644, 200 Constitution Avenue, NW, Washington, DC 20210. Do not send the completed forms to this office.

### Establishment information

Your establishment name WEMCO  
 Street 5510 W. Thorpe Rd.  
 City Spokane State WA ZIP 99224  
 Industry description (e.g., Manufacture of motor truck trailers) manufacturing  
 Standard Industrial Classification (SIC), if known (e.g., 3715) \_\_\_\_\_  
 OR \_\_\_\_\_  
 North American Industrial Classification (NAICS), if known (e.g., 336212) 333517

### Employment information (If you don't have these figures, see the Worksheet on the back of this page to estimate.)

Annual average number of employees 85  
 Total hours worked by all employees last year 170,234

### Sign here

Knowingly falsifying this document may result in a fine.

I certify that I have examined this document and that to the best of my knowledge the entries are true, accurate, and complete.

Company executive (509) 244-4773 Title President  
 Phone \_\_\_\_\_ Date 1/10/2023

# Log of Work-Related Injuries and Illnesses

**Attention:** This form contains information relating to employee health and must be used in a manner that protects the confidentiality of employees to the extent possible while the information is being used for occupational safety and health purposes.

You must record information about every work-related death and about every work-related injury or illness that involves loss of consciousness, restricted work activity or job transfer, days away from work, or medical treatment beyond first aid. You must also record significant work-related injuries and illnesses that are diagnosed by a physician or licensed health care professional. You must also record work-related injuries and illnesses that meet any of the specific recording criteria listed in 29 CFR Part 1904.8 through 1904.12. Feel free to use two lines for a single case if you need to. You must complete an Injury and Illness Incident Report (OSHA Form 301) or equivalent form for each injury or illness recorded on this form. If you're not sure whether a case is recordable, call your local OSHA office for help.

Establishment name WEMCO  
 City Spokane State WA

Identify the person		Describe the case				Classify the case				Enter the number of days the injured or ill worker was:		Check the "Injury" column or choose one type of illness:					
(A) Case no.	(B) Employee's name	(C) Job title (e.g., Welder)	(D) Date of injury or onset of illness	(E) Where the event occurred (e.g., Loading dock north end)	(F) Describe injury or illness, parts of body affected, and object/substance that directly injured or made person ill (e.g., Second degree burns on right forearm from acetylene torch)	CHECK ONLY ONE box for each case based on the most serious outcome for that case:				Away from work (K)	On job transfer or restriction (L)	(M)					
						Death (G)	Days away from work (H)	Job transfer or restriction (I)	Other recordable cases (J)	Days	Days	Injury (1)	Skin disorder (2)	Respiratory condition (3)	Poisoning (4)	Hearing loss (5)	All other illnesses (6)
1	Michael Loomis	Assembly	4/7	Assembly	Exacerbation of hernia (D)	<input type="checkbox"/>	<input type="checkbox"/>	<input checked="" type="checkbox"/>	<input type="checkbox"/>	0	125	<input checked="" type="checkbox"/>	<input type="checkbox"/>	<input type="checkbox"/>	<input type="checkbox"/>	<input type="checkbox"/>	<input type="checkbox"/>
2	Alex Pizeno	Fabricator	5/19	Fab Dept.	Hose hit chest	<input type="checkbox"/>	<input type="checkbox"/>	<input checked="" type="checkbox"/>	<input type="checkbox"/>	0	8	<input checked="" type="checkbox"/>	<input type="checkbox"/>	<input type="checkbox"/>	<input type="checkbox"/>	<input type="checkbox"/>	<input type="checkbox"/>
3	Cody Razo	Fabricator	6/9	Fab Dept.	Debris in @ eye	<input type="checkbox"/>	<input type="checkbox"/>	<input type="checkbox"/>	<input checked="" type="checkbox"/>	0	0	<input checked="" type="checkbox"/>	<input type="checkbox"/>	<input type="checkbox"/>	<input type="checkbox"/>	<input type="checkbox"/>	<input type="checkbox"/>
4	Chance Adcox	Fabricator	7/14	Fab Dept	Debris in @ eye	<input type="checkbox"/>	<input type="checkbox"/>	<input type="checkbox"/>	<input checked="" type="checkbox"/>	0	0	<input checked="" type="checkbox"/>	<input type="checkbox"/>	<input type="checkbox"/>	<input type="checkbox"/>	<input type="checkbox"/>	<input type="checkbox"/>
5	Elliott Davis	Machinist	10/4	Machine Shop	Pulled/Tore (R) shoulder	<input type="checkbox"/>	<input type="checkbox"/>	<input checked="" type="checkbox"/>	<input type="checkbox"/>	0	50	<input checked="" type="checkbox"/>	<input type="checkbox"/>	<input type="checkbox"/>	<input type="checkbox"/>	<input type="checkbox"/>	<input type="checkbox"/>
Page totals						0	0	3	2	0	183	5	0	0	0	0	0

Public reporting burden for this collection of information is estimated to average 14 minutes per response, including time to review the instructions, search and gather the data needed, and complete and review the collection of information. Persons are not required to respond to the collection of information unless it displays a currently valid OMB control number. If you have any comments about these estimates or any other aspects of this data collection, contact: US Department of Labor, OSHA Office of Statistical Analysis, Room N-3644, 200 Constitution Avenue, NW, Washington, DC 20210. Do not send the completed forms to this office.

Be sure to transfer these totals to the Summary page (Form 300A) before you post it.

# Summary of Work-Related Injuries and Illnesses



All establishments covered by Part 1904 must complete this Summary page, even if no work-related injuries or illnesses occurred during the year. Remember to review the Log to verify that the entries are complete and accurate before completing this summary.

Using the Log, count the individual entries you made for each category. Then write the totals below, making sure you've added the entries from every page of the Log. If you had no cases, write "0."

Employees, former employees, and their representatives have the right to review the OSHA Form 300 in its entirety. They also have limited access to the OSHA Form 301 or its equivalent. See 29 CFR Part 1904.35, in OSHA's recordkeeping rule, for further details on the access provisions for these forms.

### Number of Cases

Total number of deaths	Total number of cases with days away from work	Total number of cases with job transfer or restriction	Total number of other recordable cases
<u>0</u>	<u>1</u>	<u><del>1</del> 1</u>	<u>4</u>
(G)	(H)	(I)	(J)

### Number of Days

Total number of days away from work	Total number of days of job transfer or restriction
<u>2</u>	<u>9</u>
(K)	(L)

### Injury and Illness Types

Total number of . . . (M)			
(1) Injuries	<u>6</u>	(4) Poisonings	<u>0</u>
(2) Skin disorders	<u>0</u>	(5) Hearing loss	<u>0</u>
(3) Respiratory conditions	<u>0</u>	(6) All other illnesses	<u>0</u>

Post this Summary page from February 1 to April 30 of the year following the year covered by the form.

Public reporting burden for this collection of information is estimated to average 50 minutes per response, including time to review the instructions, search and gather the data needed, and complete and review the collection of information. Persons are not required to respond to the collection of information unless it displays a currently valid OMB control number. If you have any comments about these estimates or any other aspects of this data collection, contact: US Department of Labor, OSHA Office of Statistical Analysis, Room N-3644, 200 Constitution Avenue, NW, Washington, DC 20210. Do not send the completed forms to this office.

### Establishment information

Your establishment name WEMCO  
 Street 5510 W. Thorpe Rd.  
 City Spokane State WA ZIP 99224

Industry description (e.g., *Manufacture of motor truck trailers*)

manufacturing

Standard Industrial Classification (SIC), if known (e.g., 3715)

OR

North American Industrial Classification (NAICS), if known (e.g., 336212)

336212

**Employment information** (If you don't have these figures, see the Worksheet on the back of this page to estimate.)

Annual average number of employees 85

Total hours worked by all employees last year 108,413

### Sign here

Knowingly falsifying this document may result in a fine.

I certify that I have examined this document and that to the best of my knowledge the entries are true, accurate, and complete.

Karmak Rouse President  
 Company executive Title  
509 244 4173 1/8/24  
 Phone Date

# Log of Work-Related Injuries and Illnesses

**Attention:** This form contains information relating to employee health and must be used in a manner that protects the confidentiality of employees to the extent possible while the information is being used for occupational safety and health purposes.

You must record information about every work-related death and about every work-related injury or illness that involves loss of consciousness, restricted work activity or job transfer, days away from work, or medical treatment beyond first aid. You must also record significant work-related injuries and illnesses that are diagnosed by a physician or licensed health care professional. You must also record work-related injuries and illnesses that meet any of the specific recording criteria listed in 29 CFR Part 1904.8 through 1904.12. Feel free to use two lines for a single case if you need to. You must complete an Injury and Illness Incident Report (OSHA Form 301) or equivalent form for each injury or illness recorded on this form. If you're not sure whether a case is recordable, call your local OSHA office for help.

Establishment name WEMCO  
 City Spokane State WA

Identify the person			Describe the case		
(A) Case no.	(B) Employee's name	(C) Job title (e.g., Welder)	(D) Date of injury or onset of illness	(E) Where the event occurred (e.g., Loading dock north end)	(F) Describe injury or illness, parts of body affected, and object/substance that directly injured or made person ill (e.g., Second degree burns on right forearm from acetylene torch)
1	John Spicer	Welder	4/11 month/day	Fab	debris in @ eye
2	Tyler Shields	PM	5/1 month/day	I-90	Neck strain
3	John Sanborn	Engineer	5/19 month/day	I-90	Neck strain
4	Russell Kolar	Engineer	5/19 month/day	I-90	Neck strain, @ calf crushed
5	John Spicer	Welder	8/10 month/day	Fab	debris in @ eye
6	Nick Haudley	welder	12/21 month/day	Fab	@ foot smooched
			month/day		
			month/day		
			month/day		
			month/day		
			month/day		
			month/day		
			month/day		

Classify the case			
CHECK ONLY ONE box for each case based on the most serious outcome for that case:			
Death (G)	Days away from work (H)	Remained at Work	
		Job transfer or restriction (I)	Other recordable cases (J)
<input type="checkbox"/>	<input type="checkbox"/>	<input type="checkbox"/>	<input checked="" type="checkbox"/>
<input type="checkbox"/>	<input type="checkbox"/>	<input type="checkbox"/>	<input checked="" type="checkbox"/>
<input type="checkbox"/>	<input type="checkbox"/>	<input type="checkbox"/>	<input checked="" type="checkbox"/>
<input type="checkbox"/>	<input checked="" type="checkbox"/>	<input type="checkbox"/>	<input type="checkbox"/>
<input type="checkbox"/>	<input type="checkbox"/>	<input type="checkbox"/>	<input checked="" type="checkbox"/>
<input type="checkbox"/>	<input type="checkbox"/>	<input checked="" type="checkbox"/>	<input type="checkbox"/>
<input type="checkbox"/>	<input type="checkbox"/>	<input type="checkbox"/>	<input type="checkbox"/>
<input type="checkbox"/>	<input type="checkbox"/>	<input type="checkbox"/>	<input type="checkbox"/>
<input type="checkbox"/>	<input type="checkbox"/>	<input type="checkbox"/>	<input type="checkbox"/>
<input type="checkbox"/>	<input type="checkbox"/>	<input type="checkbox"/>	<input type="checkbox"/>
<input type="checkbox"/>	<input type="checkbox"/>	<input type="checkbox"/>	<input type="checkbox"/>

Enter the number of days the injured or ill worker was:	
Away from work (K)	On Job transfer or restriction (L)
0 days	0 days
0 days	0 days
0 days	0 days
2 days	0 days
0 days	0 days
0 days	9 days
days	days
days	days
days	days
days	days
days	days
days	days
days	days

**Page totals** →   1     1     4     2     9  

Be sure to transfer these totals to the Summary page (Form 300A) before you post it.

Page 1 of 1

Check the "Injury" column or choose one type of illness:						
(M)	Injury	Skin disorder	Respiratory condition	Poisoning	Hearing loss	All other illnesses
(1)	<input checked="" type="checkbox"/>	<input type="checkbox"/>	<input type="checkbox"/>	<input type="checkbox"/>	<input type="checkbox"/>	<input type="checkbox"/>
(2)	<input checked="" type="checkbox"/>	<input type="checkbox"/>	<input type="checkbox"/>	<input type="checkbox"/>	<input type="checkbox"/>	<input type="checkbox"/>
(3)	<input checked="" type="checkbox"/>	<input type="checkbox"/>	<input type="checkbox"/>	<input type="checkbox"/>	<input type="checkbox"/>	<input type="checkbox"/>
(4)	<input checked="" type="checkbox"/>	<input type="checkbox"/>	<input type="checkbox"/>	<input type="checkbox"/>	<input type="checkbox"/>	<input type="checkbox"/>
(5)	<input checked="" type="checkbox"/>	<input type="checkbox"/>	<input type="checkbox"/>	<input type="checkbox"/>	<input type="checkbox"/>	<input type="checkbox"/>
(6)	<input checked="" type="checkbox"/>	<input type="checkbox"/>	<input type="checkbox"/>	<input type="checkbox"/>	<input type="checkbox"/>	<input type="checkbox"/>
	<input type="checkbox"/>	<input type="checkbox"/>	<input type="checkbox"/>	<input type="checkbox"/>	<input type="checkbox"/>	<input type="checkbox"/>
	<input type="checkbox"/>	<input type="checkbox"/>	<input type="checkbox"/>	<input type="checkbox"/>	<input type="checkbox"/>	<input type="checkbox"/>
	<input type="checkbox"/>	<input type="checkbox"/>	<input type="checkbox"/>	<input type="checkbox"/>	<input type="checkbox"/>	<input type="checkbox"/>
	<input type="checkbox"/>	<input type="checkbox"/>	<input type="checkbox"/>	<input type="checkbox"/>	<input type="checkbox"/>	<input type="checkbox"/>
	<input type="checkbox"/>	<input type="checkbox"/>	<input type="checkbox"/>	<input type="checkbox"/>	<input type="checkbox"/>	<input type="checkbox"/>
	<input type="checkbox"/>	<input type="checkbox"/>	<input type="checkbox"/>	<input type="checkbox"/>	<input type="checkbox"/>	<input type="checkbox"/>
	<input type="checkbox"/>	<input type="checkbox"/>	<input type="checkbox"/>	<input type="checkbox"/>	<input type="checkbox"/>	<input type="checkbox"/>
	<input type="checkbox"/>	<input type="checkbox"/>	<input type="checkbox"/>	<input type="checkbox"/>	<input type="checkbox"/>	<input type="checkbox"/>
	<input type="checkbox"/>	<input type="checkbox"/>	<input type="checkbox"/>	<input type="checkbox"/>	<input type="checkbox"/>	<input type="checkbox"/>
	<input type="checkbox"/>	<input type="checkbox"/>	<input type="checkbox"/>	<input type="checkbox"/>	<input type="checkbox"/>	<input type="checkbox"/>
	<input type="checkbox"/>	<input type="checkbox"/>	<input type="checkbox"/>	<input type="checkbox"/>	<input type="checkbox"/>	<input type="checkbox"/>
	<input type="checkbox"/>	<input type="checkbox"/>	<input type="checkbox"/>	<input type="checkbox"/>	<input type="checkbox"/>	<input type="checkbox"/>
	<input type="checkbox"/>	<input type="checkbox"/>	<input type="checkbox"/>	<input type="checkbox"/>	<input type="checkbox"/>	<input type="checkbox"/>

Public reporting burden for this collection of information is estimated to average 14 minutes per response, including time to review the instructions, search and gather the data needed, and complete and review the collection of information. Persons are not required to respond to the collection of information unless it displays a currently valid OMB control number. If you have any comments about these estimates or any other aspects of this data collection, contact: US Department of Labor, OSHA Office of Statistical Analysis, Room N-3644, 200 Constitution Avenue, NW, Washington, DC 20210. Do not send the completed forms to this office.

235000992166700171110111

State of Washington  
 Department of Labor and Industries  
 PO Box 44140  
 Olympia WA 98504-4140

**THIS IS  
 NOT A  
 BILL**

12-08-23

DEC 13 2023

**Policyholder**  
**WEMCO INC**  
**5510 W THORPE RD**  
**SPOKANE WA 99224**

<b>Rate Notice: WA Workers' Compensation</b>	
Effective Date:	Experience Factor <sup>4</sup> :
<b>January 1, 2024</b>	<b>0.6000</b>
Experience Period:	
<b>July 1, 2019 - June 30, 2022</b>	
WA Unified Business Identifier (UBI):	
<b>601 174 038</b>	
L&I Account ID:	PAC Number:
<b>560,436-00</b>	<b>32179186</b>
Account Manager:	
<b>JAVIER PAREDES</b>	
<b>(360)902-6266</b>	

**What went into calculating your 2024 workers' comp rates?**

- 1. Change in L&I average 'base' rate:** 4.9% average rate increase for 2024; rates specific to your industry can be found on our website at [lni.wa.gov](http://lni.wa.gov)
- 2. Changes in industry costs:** Changes in claim costs compared to premiums collected for your industry ('risk class') in which some or all of your employees worked.
- 3. Your Experience Factor:** Based on the medical, wage replacement and disability benefit costs for worker claims on your account, during the experience period listed above.
- 4. A claim-free discount:** You earned a 40% claim-free discount in your Experience Factor. Learn how to keep the discount at [www.Lni.wa.gov/ClaimFreeDiscount](http://www.Lni.wa.gov/ClaimFreeDiscount).

Pay your premiums online: [www.Lni.wa.gov/QuarterlyReports](http://www.Lni.wa.gov/QuarterlyReports)

Need help understanding this notice? Call your account manager at the phone number shown above.

*Have a payroll service?  
 Send them a copy of this notice.*

Your Rate Information	Class Code	Class Code Description	Accident Fund (AF) <sup>1</sup>	Medical Aid Fund (MA) <sup>2</sup>	Stay at Work Program <sup>3</sup>	Supp. Pension Fund (SP) <sup>5</sup>	Hourly* Employer Contribution	Hourly* Employee Withholding	= Your Total Hourly* Rate [(1+2+3)x4]+5
		4904-00	Clerical Office NOC & Draftsmn	0.0183	0.0112	0.0003	0.1710	\$0.09995	\$0.08895
	5109-46	Hvy Mach & Equip Mfg or Rpr	0.7108	0.3022	0.0108	0.1710	\$0.60590	\$0.17940	\$0.7853
	6303-00	Sales Personnel NOC-Outside	0.0698	0.0342	0.0011	0.1710	\$0.13800	\$0.09610	\$0.2341
	7101-00	Corp Officer NOC (admin only)	0.0416	0.0160	0.0006	0.1710	\$0.11540	\$0.09050	\$0.2059

Your experience factor history:

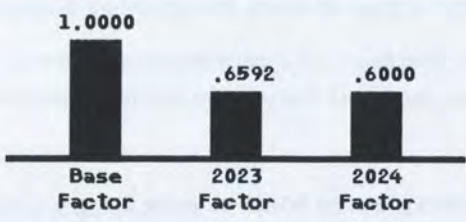

This is the employer's contribution to workers' comp coverage.

Withhold this amount from employee pay for each hour\* they work. It is their contribution to workers' comp coverage.

On the Quarterly Report, the employer will multiply this number by the hours\* worked to calculate premiums.

**What's an experience factor?**  
 See back for an explanation.



**OSHA LOG SUMMARY AND INJURY RATES**

<b>YEAR</b>	<b>2024</b>	<b>2023</b>	<b>2022</b>	<b>2021</b>	<b>2020</b>	<b>2019</b>	<b>2018</b>	<b>2017</b>	<b>2016</b>	<b>2015</b>	<b>2014</b>
<b>TOTAL RECORDABLE INJURIES</b>	0	6	5	3	5	8	3	3	9	7	5
<b>TIME LOSS DAYS</b>	0	2	0	0	0	5	0	0	3	0	0
<b>JOB TRANSFER DAYS</b>	0	9	125	0	113	125	0	43	411	0	?
<b>EMR</b>	.60	.66	.88	1.17	.93	.75	.60	.60	.60	.62	.67
<b>TOTAL RECORDABLE INJURY RATE (TRIR)</b>	0	7.11	5.87	3.48	6.31	12.49	7.04	6.77	15.07	14.53	15.48
<b>AVG # OF EMPLOYEES</b>	85	85	85	85	76	61	41	43	54	48	36
<b>TOTAL HOURS WORKED</b>	TBD	168,613	170,234	171,951	158,234	128,065	85,179	88,605	119,438	96,312	64,578
<b>CASES WITH DAYS AWAY OR RESTRICTIONS</b>	0	2	3	0	3	3	0	1			
<b>DART RATE</b>	0	2.37	3.5	0	3.79	4.68	0	2.25			

TRIR = # OF INJURIES x 200,000 ÷ HOURS WORKED

DART = # OF INJURIES WITH DAYS AWAY OR RESTRICTIONS x 200,000 ÷ HOURS WORKED



**HEREBY GRANTS  
WOMAN OWNED SMALL BUSINESS (WOSB) CERTIFICATION TO**

**Washington Equipment Manufacturing Company, Inc. DBA WEMCO INC.**

The identified small business is an eligible WOSB for the WOSB Program, as set forth in 13 C.F.R. part 127 and has been certified as such by an SBA approved Third Party Certifier pursuant to the Third Party Agreement, dated June 30, 2011, and available at [www.sba.gov/wosb](http://www.sba.gov/wosb).

The WOSB Certification expires on the date herein unless there is a change to the SBA's regulation that makes the WOSB ineligible or there is a change in the WOSB that makes the WOSB ineligible. If either occurs, this WOSB Certification is immediately invalid. The WOSB must not misrepresent its certification status to any other party, including any local or State government or contracting official or the Federal government or any of its contracting officials.

Majority Female Owner: Karma Rouse
NAICS: 333923, 236210, 237990, 238290, 332312, 332313, 332721, 332999, 333111, 333120, 333132, 333517, 333922, 336413, 811310 UNSPSC: 21101700, 21101703, 23242401, 23290000, 24101602, 24101619, 24101652, 24101653, 24101654, 31391500, 73161516
Certification Number: WOSB210143
Renewal Date: January 31, 2025
WOSB Regulation Expiration Date: 1/31/2027



Janice Greene, PhD, Women's Business Enterprise Council - Pacific President & CEO

Pamela Prince-Easton, WBENC President & CEO

LaKesha White, Vice President, Certification



< Business Lookup

License Information:

[New search](#) [Back to results](#)

**Entity name:** WASHINGTON EQUIPMENT MANUFACTURING COMPANY, INC.

**Business name:** WASHINGTON EQUIPMENT MANUFACTURING COMPANY, INC.

**Entity type:** [Profit Corporation](#)

**UBI #:** 601-174-038

**Business ID:** 001

**Location ID:** 0001

**Location:** Active

**Location address:** 5510 W THORPE RD  
SPOKANE WA 99224-5371

**Mailing address:** 5510 W THORPE RD  
SPOKANE WA 99224-5371

**Excise tax and reseller permit status:** [Click here](#)

**Secretary of State status:** [Click here](#)

Endorsements

Endorsements held at this location	License #	Count	Details	Status	Expiration date	First issuance date
<a href="#">Minor Work Permit</a>				Active	Apr-30-2025	Feb-24-2020
<a href="#">Moses Lake General Business - Non-Resident</a>	BUS2020-0349			Active	Apr-30-2025	May-18-2020
<a href="#">Spokane General Business - Non-Resident</a>	T12003901BUS			Active	Apr-30-2025	Oct-15-2012

Governing People May include governing people not registered with Secretary of State

Governing people	Title
ROUSE, JOHN	
ROUSE, JUSTON	
ROUSE, KARMA	
TURNER, MATTHEW	

Registered Trade Names

Registered trade names	Status	First issued
WEMCO INC	Active	May-02-1989

The Business Lookup information is updated nightly. Search date and time: 10/2/2024 1:59:11 PM

[Contact us](#)

How are we doing?  
[Take our survey!](#)

Don't see what you expected?  
[Check if your browser is supported](#)





WEMCINC-01

SSIMPSON1

# CERTIFICATE OF LIABILITY INSURANCE

DATE (MM/DD/YYYY)

4/30/2024

**THIS CERTIFICATE IS ISSUED AS A MATTER OF INFORMATION ONLY AND CONFERS NO RIGHTS UPON THE CERTIFICATE HOLDER. THIS CERTIFICATE DOES NOT AFFIRMATIVELY OR NEGATIVELY AMEND, EXTEND OR ALTER THE COVERAGE AFFORDED BY THE POLICIES BELOW. THIS CERTIFICATE OF INSURANCE DOES NOT CONSTITUTE A CONTRACT BETWEEN THE ISSUING INSURER(S), AUTHORIZED REPRESENTATIVE OR PRODUCER, AND THE CERTIFICATE HOLDER.**

**IMPORTANT: If the certificate holder is an ADDITIONAL INSURED, the policy(ies) must have ADDITIONAL INSURED provisions or be endorsed. If SUBROGATION IS WAIVED, subject to the terms and conditions of the policy, certain policies may require an endorsement. A statement on this certificate does not confer rights to the certificate holder in lieu of such endorsement(s).**

<b>PRODUCER</b> Hub International Northwest LLC PO Box 3144 Spokane, WA 99220	CONTACT NAME: <b>Stacia Simpson</b>
	PHONE (A/C, No, Ext): <b>(509) 319-2912</b> FAX (A/C, No):
	E-MAIL ADDRESS: <b>Stacia.Simpson@hubinternational.com</b>
	INSURER(S) AFFORDING COVERAGE      NAIC #
	INSURER A : <b>Berkley Specialty Insurance Company</b> <b>31295</b>
	INSURER B : <b>Alaska National Insurance Company</b> <b>38733</b>
	INSURER C : <b>Navigators Specialty Insurance Company</b> <b>36056</b>
	INSURER D :
	INSURER E :
	INSURER F :

**INSURED**  
  
**WEMCO, Inc.**  
**5510 W Thorpe Road**  
**Spokane, WA 99224**

**COVERAGES**

**CERTIFICATE NUMBER:**

**REVISION NUMBER:**

THIS IS TO CERTIFY THAT THE POLICIES OF INSURANCE LISTED BELOW HAVE BEEN ISSUED TO THE INSURED NAMED ABOVE FOR THE POLICY PERIOD INDICATED. NOTWITHSTANDING ANY REQUIREMENT, TERM OR CONDITION OF ANY CONTRACT OR OTHER DOCUMENT WITH RESPECT TO WHICH THIS CERTIFICATE MAY BE ISSUED OR MAY PERTAIN, THE INSURANCE AFFORDED BY THE POLICIES DESCRIBED HEREIN IS SUBJECT TO ALL THE TERMS, EXCLUSIONS AND CONDITIONS OF SUCH POLICIES. LIMITS SHOWN MAY HAVE BEEN REDUCED BY PAID CLAIMS.

INSR LTR	TYPE OF INSURANCE	ADDL INSD	SUBR WVD	POLICY NUMBER	POLICY EFF (MM/DD/YYYY)	POLICY EXP (MM/DD/YYYY)	LIMITS	
<b>A</b>	<b>COMMERCIAL GENERAL LIABILITY</b> <input type="checkbox"/> CLAIMS-MADE <input checked="" type="checkbox"/> OCCUR  GEN'L AGGREGATE LIMIT APPLIES PER: <input type="checkbox"/> POLICY <input checked="" type="checkbox"/> PROJECT <input type="checkbox"/> LOC OTHER:	<b>X</b>	<b>X</b>	<b>CGL003439336</b>	<b>5/1/2024</b>	<b>5/1/2025</b>	EACH OCCURRENCE	\$ <b>1,000,000</b>
							DAMAGE TO RENTED PREMISES (Ea occurrence)	\$ <b>100,000</b>
							MED EXP (Any one person)	\$ <b>5,000</b>
							PERSONAL & ADV INJURY	\$ <b>1,000,000</b>
							GENERAL AGGREGATE	\$ <b>2,000,000</b>
							PRODUCTS - COMP/OP AGG	\$ <b>2,000,000</b>
							<b>WA STOP GAP</b>	\$ <b>1,000,000</b>
<b>B</b>	<b>AUTOMOBILE LIABILITY</b> <input checked="" type="checkbox"/> ANY AUTO OWNED AUTOS ONLY <input type="checkbox"/> SCHEDULED AUTOS <input checked="" type="checkbox"/> HIRED AUTOS ONLY <input checked="" type="checkbox"/> NON-OWNED AUTOS ONLY	<b>X</b>	<b>X</b>	<b>24EAS08952</b>	<b>5/1/2024</b>	<b>5/1/2025</b>	COMBINED SINGLE LIMIT (Ea accident)	\$ <b>1,000,000</b>
							BODILY INJURY (Per person)	\$
							BODILY INJURY (Per accident)	\$
							PROPERTY DAMAGE (Per accident)	\$
								\$
<b>C</b>	<b>UMBRELLA LIAB</b> <input checked="" type="checkbox"/> OCCUR <input checked="" type="checkbox"/> EXCESS LIAB <input type="checkbox"/> CLAIMS-MADE DED    RETENTION \$	<b>X</b>	<b>X</b>	<b>SE24EXCZ01Y6BIC</b>	<b>5/1/2024</b>	<b>5/1/2025</b>	EACH OCCURRENCE	\$ <b>5,000,000</b>
							AGGREGATE	\$ <b>5,000,000</b>
								\$
	<b>WORKERS COMPENSATION AND EMPLOYERS' LIABILITY</b> ANY PROPRIETOR/PARTNER/EXECUTIVE OFFICER/MEMBER EXCLUDED? (Mandatory in NH) <input type="checkbox"/> Y / N If yes, describe under DESCRIPTION OF OPERATIONS below		<b>N / A</b>				PER STATUTE    OTH-ER	
							E.L. EACH ACCIDENT	\$
							E.L. DISEASE - EA EMPLOYEE	\$
							E.L. DISEASE - POLICY LIMIT	\$
<b>B</b>	<b>Installation Floater</b>			<b>24EIA08952</b>	<b>5/1/2024</b>	<b>5/1/2025</b>	<b>COC Limit</b>	<b>1,000,000</b>

DESCRIPTION OF OPERATIONS / LOCATIONS / VEHICLES (ACORD 101, Additional Remarks Schedule, may be attached if more space is required)  
 PROJECT: PW ITB 5101-19 REFUSE CRANES QUARTERLY PREVENTIVE MAINTENANCE INSPECTIONS AND UNSCHEDULED SERVICES FOR TWO 9-TON, TOP RUNNING DOUBLE GRINDER (TRDG) BRIDGE CRANES

THE CITY OF SPOKANE, ITS OFFICERS AND EMPLOYEES ARE ADDITIONAL INSURED AS RESPECTS TO THE GENERAL & AUTO LIABILITY & WAIVER OF SUBROGATION IS GRANTED AS IT RELATES TO THE GENERAL & AUTO LIABILITY WITH THE TERMS AND CONDITIONS OF THE POLICIES. UMBRELLA FOLLOWS FORMS. THE COVERAGE IS PRIMARY AND NON-CONTRIBUTORY WHERE REQUIRED BY A WRITTEN CONTRACT.

**CERTIFICATE HOLDER**

**CANCELLATION**

CITY OF SPOKANE 2900 S GEIGER BLVD. ATTN: MICHELLE DORGAN SPOKANE, WA 99224	SHOULD ANY OF THE ABOVE DESCRIBED POLICIES BE CANCELLED BEFORE THE EXPIRATION DATE THEREOF, NOTICE WILL BE DELIVERED IN ACCORDANCE WITH THE POLICY PROVISIONS.
	AUTHORIZED REPRESENTATIVE 

# WAIVER OF TRANSFER OF RIGHTS OF RECOVERY AGAINST OTHERS TO US

This endorsement modifies insurance provided under the following:

COMMERCIAL GENERAL LIABILITY COVERAGE PART  
PRODUCTS/COMPLETED OPERATIONS LIABILITY COVERAGE PART

## SCHEDULE

**Name Of Person Or Organization:**

All Persons or Organizations when such Waiver is required by written contract with you and executed prior to the occurrence of the injury or damage for which we make payments on your behalf.

Information required to complete this Schedule, if not shown above, will be shown in the Declarations.

The following is added to Paragraph 8. **Transfer Of Rights Of Recovery Against Others To Us** of Section IV – Conditions:

We waive any right of recovery we may have against the person or organization shown in the Schedule above because of payments we make for injury or damage arising out of your ongoing operations or "your work" done under a contract with that person or organization and included in the "products-completed operations hazard". This waiver applies only to the person or organization shown in the Schedule above.

THIS ENDORSEMENT CHANGES THE POLICY. PLEASE READ IT CAREFULLY.

**ADDITIONAL INSURED - PRIMARY AND NONCONTRIBUTORY -  
AUTOMATIC STATUS WHEN REQUIRED IN A WRITTEN CONTRACT OR  
AGREEMENT  
(Including Completed Operations)**

This endorsement modifies insurance provided under the following:

COMMERCIAL GENERAL LIABILITY COVERAGE PART

**SCHEDULE**

**Date:** 5/1/2023

**A. Section II - Who Is An Insured is amended** to include as an additional insured any person or organization for whom you are performing operations when you and such person or organization have agreed in writing in a contract or agreement that such person or organization be added as an additional insured on your policy. Such person or organization is an additional insured only with respect to liability for "bodily injury", "property damage" or "personal and advertising injury" caused, in whole or in part, by:

1. Your acts or omissions, or the acts or omissions of those acting on your behalf in the performance of your ongoing operations for the additional insured; or
2. "Your work" and included in the "products-completed operations hazard".

but only for "occurrences" or coverages not otherwise excluded in the Coverage Part to which this endorsement applies.

However the insurance afforded to such additional insured:

1. Only applies to the extent permitted by law; and
2. Will not be broader than that which you are required by the contract or agreement to provide for such additional insured.

**B.** Status as an additional insured for the person or organization to which this endorsement applies commences during the policy period and after such written contract or agreement has been executed.

**C.** With respect to the insurance afforded to the additional insured, the following additional exclusions apply:

This insurance does not apply to:

1. "Bodily injury", "property damage", "personal and advertising injury" or medical payments arising out of the rendering of, or the failure to render, any professional architectural, engineering or surveying services, including:
  - a. The preparing, approving, or failure to prepare or approve, maps, shop drawings, opinions, reports, surveys, field orders, change orders or drawings and specifications; or
  - b. Supervisory, inspection, architectural or engineering activities.

This exclusion applies even if the claims against any insured allege negligence or other wrongdoing in the supervision, hiring, employment, training or monitoring of others by that insured, if the "occurrence" which caused the "bodily injury" or "property damage", or the offense which caused the "personal and advertising injury", involved the rendering of or the failure to render any professional architectural, engineering, or surveying services.

2. "Bodily injury" or "property damage" included in the "products-completed operations hazard" and arising out of "your work" that was completed by or on behalf of any insured prior to the date shown in the Schedule of this endorsement.

**D. With respect to the insurance afforded to the additional insured, the following is added to **Section III – Limits Of Insurance:****

The most we will pay on behalf of the additional insured is the amount of insurance:

1. Required by the contract or agreement you have entered into with the additional insured; or
2. Available under the applicable limits of insurance;

whichever is less.

This endorsement shall not increase the applicable limits of insurance.

**E. The following condition is added to 4.a. of **Other Insurance** of **Section IV - Commercial General Liability Conditions:****

If required in a written contract, the Coverage Part to which this endorsement applies is primary and noncontributory in the event of an "occurrence" caused, in whole or in part, by your acts or omissions, or the acts or omissions of those acting on your behalf that:

1. Occurs while performing ongoing operations for the additional insured, or
2. Is included in the "products-completed operations hazard" and arises out of "your work" that was completed by or on behalf of any insured after the date shown in the Schedule of this endorsement.

All other terms and conditions remain unchanged.



**THIS ENDORSEMENT CHANGES THE POLICY. PLEASE READ IT CAREFULLY.**

**AMENDMENT OF CONDITIONS  
OTHER INSURANCE  
PRIMARY AND NON-CONTRIBUTING**

This endorsement modifies insurance provided under the following:

COMMERCIAL EXCESS LIABILITY COVERAGE PART

SCHEDULE

When required by written contract executed before the "loss."

- A. Section IV - Conditions, 9. Other Insurance is deleted and replaced by the following:
  - 9. This insurance is excess over any other insurance available to the insured except:
    - a. insurance that is purchased specifically to apply in excess of this policy; or
    - b. insurance available to the person or organization shown in the Schedule of this endorsement as an additional insured on the "controlling underlying insurance."
- B. When this insurance applies on a primary and non-contributing basis, the Limits of Insurance available for the additional insured will be the lesser of:
  - 1. the amounts shown in item 3 of the Declarations of this policy; or
  - 2. the amount of insurance you are required to provide the additional insured in the written contract or agreement.

All other terms of the policy remain unchanged.

**SECTION II – WHO IS AN INSURED**

The WHO IS AN INSURED section of the “controlling underlying insurance” is made part of this policy. Any person or organization that is an insured in “controlling underlying insurance” is an insured in this policy to the same extent.

**SECTION III – LIMITS OF INSURANCE**

The Limits of Insurance shown in the Declarations and the rules below fix the most we will pay regardless of the number of insureds, claims made or suits brought, or persons or organizations making claims or bringing suits.

1. The General Aggregate Limit is the most we will pay for the sum of all damages to which this insurance applies, except:
  - a. damages because of bodily injury or property damage included within any applicable products-completed operations hazard; or
  - b. damages arising out of the ownership, operation, maintenance or use of an automobile;
2. The Products-Completed Operations Aggregate Limit is the most we will pay for the sum of all damages included within any applicable products-completed operations hazard;
3. Subject to paragraphs 1. and 2. above, the Each Event Limit is the most we will pay for all damages that arise out of any one “event.”

**SECTION IV – CONDITIONS**

The CONDITIONS sections of the “controlling underlying insurance” are made part of this policy. If an inconsistency or contradiction exists between the Conditions of this policy and the Conditions of the “controlling underlying insurance,” the Conditions of this policy will apply.

1. Appeals  
At our discretion we may appeal any judgment which would result in a payment under this policy. When we do appeal, we will pay all costs associated with the appeal in addition to the Limits of Insurance. Any such appeal will not increase our Limits of Insurance.
2. Bankruptcy or Insolvency  
Bankruptcy or insolvency of the insured or the insured's estate will not relieve us of our obligations under this policy. Bankruptcy or insolvency of any company providing “controlling underlying insurance” will not reduce the “underlying limits” or increase our obligations under this policy. We will not be required to drop down or replace “controlling underlying insurance.”
3. Cancellation
  - a. The first Named Insured may cancel this policy at any time by providing us advanced written notice of the cancellation date.
  - b. We may cancel this policy at any time by providing the first Named Insured written notice of cancellation:
    - i. at least 10 days in advance if we cancel for non-payment of premium; or
    - ii. at least 30 days in advance if we cancel for any other reason:

- d. No insured will, except at that insured's own cost, voluntarily make a payment, assume any obligation or incur any expense, other than first aid, without our consent. Notice to us may be sent to our address shown in the Declarations.
7. **Legal Action Against Us**  
No person or organization has a right under this insurance:
- to join us as a party or otherwise bring us into a suit asking for damages from an insured; or
  - to sue us on this insurance unless all of its terms have been fully complied with.
8. **Maintenance of Controlling Underlying Insurance**  
During the "policy period" you must maintain "controlling underlying insurance" with "underlying limits" at least equal to the amounts shown in the Declarations. The "underlying limits" must be unimpaired at the beginning of this "policy period." If you fail to maintain the "controlling underlying insurance" this policy will be invalid. If you fail to maintain "underlying limits," we will only be liable to the extent we would have been liable had you maintained the "underlying limits." Reduction of "underlying limits" by the payment of judgments or settlements for "loss" to which this insurance applies, or would have applied but for the amount of the damages, will not be considered a failure to maintain "underlying limits."
9. **Other Insurance**  
This insurance is excess over any insurance available to the insured except insurance purchased specifically to apply in excess of this policy.
10. **Payment of Damages**  
When the amount of damages payable under this policy has been determined by final judgment or a written settlement agreement between the claimant and us, we will pay that amount, up to our applicable Limits of Insurance, after the "controlling underlying insurance" or the insured has paid the full amount of the "underlying limits."
11. **Premium**  
The Premium shown in the Declarations is the premium for the coverage we provide for the "policy period." The first Named Insured is responsible for the payment of all premiums under this policy. If this policy is cancelled prior to its expiration date return premium will be calculated as follows:
- if cancelled by us:  
$$\{[(\text{Premium}) - (\text{Minimum Earned Premium})] \times (\text{Pro Rata factor})\}$$
  - if cancelled by you:  
$$\{[(\text{Premium}) - (\text{Minimum Earned Premium})] \times \{(\text{Pro Rata factor}) \times (.90)\}\}$$
12. **Separation of Insureds**  
Except with respect to the Limits of Insurance and any rights or duties specifically assigned in this policy to the first Named Insured, this insurance applies:
- as if each Named Insured were the only Named Insured; and
  - separately to each insured against whom claim is made or suit is brought.
13. **Transfer of Rights of Recovery Against Others**  
If an insured has rights to recover all or part of any payment we have made under this insurance, the insured must preserve those rights and, at our request, pursue or transfer those rights to us. The insured must do nothing after an "event" to impair them.

**THIS ENDORSEMENT CHANGES THE POLICY. PLEASE READ IT CAREFULLY.**

**CONSTRUCTION PROJECT GENERAL AGGREGATE LIMIT WHEN  
REQUIRED BY CONTRACT AND  
MAXIMUM PER POLICY GENERAL AGGREGATE LIMIT**

This Endorsement modifies insurance provided under the following:

**COMMERCIAL GENERAL LIABILITY COVERAGE PART**

**SCHEDULE**

**Limits of Insurance**

Maximum Per Policy General Aggregate Limit \$5,000,000

- A. For all sums which the insured becomes legally obligated to pay as damages caused by "occurrences" under **Section I - Coverage A - Bodily Injury And Property Damage Liability**, and for all medical expenses caused by accidents under **Section I - Coverage C - Medical Payments**, which can be attributed only to ongoing operations at a single construction project:
1. A separate Construction Project General Aggregate Limit applies to each construction project when required in a written construction contract or agreement, and that limit is equal to the amount of the General Aggregate Limit shown in the Declarations.
  2. The Construction Project General Aggregate Limit is the most we will pay for the sum of all damages under **Coverage A**, except damages because of "bodily injury" or "property damage" included in the "products-completed operations hazard", and for medical expenses under **Coverage C** regardless of the number of:
    - a. Insureds;
    - b. Claims made or "suits" brought; or
    - c. Persons or organizations making claims or bringing "suits".
  3. Any payments made under **Coverage A** for damages or under **Coverage C** for medical expenses shall reduce the Construction Project General Aggregate Limit for that construction project. Such payments shall not reduce the General Aggregate Limit shown in the Declarations nor shall they reduce any other Construction Project General Aggregate Limit for any other construction project.
  4. The limits shown in the Declarations for Each Occurrence, Damage To Premises Rented To You and Medical Expense continue to apply. However, instead of being subject to the General Aggregate Limit shown in the Declarations, such limits will be subject to the applicable Construction Project General Aggregate Limit.
  5. The Maximum Per Policy General Aggregate Limit shown in the Schedule is the most we will pay for the sum of all Construction Project General Aggregate Limits and the General Aggregate Limit shown in the Declarations regardless of the number of:
    - a. Insureds;
    - b. Claims made or "suits" brought;
    - c. Persons or organizations making claims or bringing "suits"; or
    - d. Construction projects.

- B. For all sums which the insured becomes legally obligated to pay as damages caused by "occurrences" under **Section I - Coverage A - Bodily Injury And Property Damage Liability**, and for all medical expenses caused by accidents under **Section I - Coverage C - Medical Payments**, which cannot be attributed only to ongoing operations at a single construction project:
1. Any payments made under **Coverage A** for damages or under **Coverage C** for medical expenses shall reduce the amount available under the General Aggregate Limit shown in the Declarations or the Products-Completed Operations Aggregate Limit shown in the Declarations, whichever is applicable; and
  2. Such payments shall not reduce any Construction Project General Aggregate Limit.
- C. When coverage for liability arising out of the "products-completed operations hazard" is provided, any payments for damages because of "bodily injury" or "property damage" included in the "products-completed operations hazard" will reduce the Products-Completed Operations Aggregate Limit shown in the Declarations, and not reduce the General Aggregate Limit shown in the Declarations nor the Construction Project General Aggregate Limit.
- D. If the applicable construction project has been abandoned, delayed, or abandoned and then restarted, or if the authorized contracting parties deviate from plans, blueprints, designs, specifications, or timetables, the project will still be deemed to be the same construction project.
- E. The provisions of **Section III - Limits Of Insurance** not otherwise modified by this endorsement shall continue to apply as stipulated.

All other terms and conditions of this policy remain unchanged.

**THIS ENDORSEMENT CHANGES THE POLICY. PLEASE READ IT CAREFULLY.**

## **WAIVER OF SUBROGATION**

### **SCHEDULE**

**Name of Person or Organization:**

As required by written contract or agreement.

Information required to complete this Schedule, if not shown above, will be shown in the Declarations.

The following is added to SECTION IV - CONDITIONS, 13. Transfer of Rights of Recovery Against Others.

We waive any right of recovery we may have against the person or organization shown in the Schedule above because of payments we make for injury or damage arising out of your ongoing operations or "your work" done under a contract with that person or organization. This waiver applies only to the person or organization shown in the Schedule above.

All other terms of the policy remain unchanged.

---

**WAIVER OF OUR RIGHT TO RECOVER FROM OTHERS ENDORSEMENT**

---

We have the right to recover our payments from anyone liable for an injury covered by this policy. We will not enforce our right against the person or organization named in the Schedule. (This agreement applies only to the extent that you perform work under

a written contract that requires you to obtain this agreement from us.)

This agreement shall not operate directly or indirectly to benefit any one not named in the Schedule.

**SCHEDULE**

Any person or organization for whom the Insured has agreed by written contract to furnish this waiver.

This endorsement changes the policy to which it is attached and, unless otherwise stated, is effective on the date issued at 12:01 A.M. standard time at your mailing address shown in the policy. **The information below is required only when this endorsement is issued subsequent to commencement of the policy.**

Endorsement Effective 5/1/2024

Policy No. 24HWS08952

Insured WEMCO, Inc.

Endorsement No. 5

Countersigned By \_\_\_\_\_



---

**BUSINESS AUTO COVERAGE ENHANCEMENT ENDORSEMENT**

---

**THIS ENDORSEMENT CHANGES THE POLICY. PLEASE READ IT CAREFULLY.**

This endorsement modifies insurance provided under the following:

**BUSINESS AUTO COVERAGE FORM**

Various provisions in this endorsement restrict coverage. Read the entire policy carefully to determine rights, duties, and what is and is not covered.

Throughout this policy, the words “you” and “your” refer to the Named Insured shown in the Declarations. The words “we”, “us”, and “our” refer to the company providing this insurance.

Other words and phrases that appear in quotation marks have special meaning. Refer to **SECTION V – DEFINITIONS** in the Business Auto Coverage Form.

The coverages provided by this endorsement apply per “accident” and, unless otherwise specified, are subject to all of the terms, conditions, exclusions and deductible provisions of the policy, to which it is attached.

**SECTION II – COVERED AUTO LIABILITY COVERAGE**, Paragraph A.1. Who Is An Insured is amended to include:

- d. Any “employee” of yours while operating an “auto” hired or rented under a contract or agreement in an “employee’s” name, with your permission, while performing duties related to the conduct of your business.
- e. Any person or organization for whom you have agreed in writing to provide insurance such as is afforded by this Coverage Form, but only with respect to liability arising out of the ownership, maintenance or use of “autos” covered by this policy. If such person or organization has other insurance then this insurance is primary to and we will not seek contribution from the other insurance.

**SECTION IV – Business Auto Conditions, Paragraph A. 5. – Transfer of Rights of Recovery Against Others To Us** is amended to include:

**5. Transfer of Rights of Recovery Against Others to Us**

This condition does not apply to any person(s) or organization(s) to the extent that subrogation against that person or organization is waived prior to the “accident” or the “loss” under a contract with that person or organization.

**SECTION II – COVERED AUTO LIABILITY COVERAGE**, Paragraph A.2.a. (2) – **Supplementary Payments** is replaced by the following:

- (2) Up to \$10,000 for cost of bail bonds (including bonds for related traffic law violations) required because of an “accident” we cover. We do not have to furnish these bonds.

**SECTION II – COVERED AUTO LIABILITY COVERAGE**, Paragraph A.2.a. (4) – **Supplementary Payments** is replaced by the following:

- (4) All reasonable expenses incurred by the “insured” at our request, including actual loss of earnings up to \$500 a day because of time off from work.



**SECTION II – COVERED AUTO LIABILITY COVERAGE**, Paragraph A.2.c. – **Voluntary Property Damage** is added as follows:

**c. Voluntary Property Damage**

At your written request, we may make a voluntary payment for Property Damage caused by an “insured”, but without liability to a third party, up to \$25,000. We will not make a Voluntary Property Damage payment to anyone who is an “insured” under this policy.

**SECTION III – PHYSICAL DAMAGE COVERAGE**, Paragraph A.2. – **Towing** is replaced by the following:

**Towing**

We will pay up to \$500 for towing and labor costs incurred each time a covered “auto” that is a:

- a. Private passenger;
- b. Truck;
- c. Pick-up truck;
- d. Panel ; or
- e. Van

type vehicle under 20,000 lbs. of Gross Vehicle Weight is disabled. However, the labor must be performed at place of disablement.

**SECTION III – PHYSICAL DAMAGE COVERAGE**, Paragraph A.3. – **Glass Breakage – Hitting a Bird or Animal – Falling Objects or Missiles** is replaced by the following:

**Glass Breakage – Hitting a Bird or Animal – Falling Objects or Missiles**

If you carry Comprehensive Coverage for the damaged covered “auto”, we will pay the following under Comprehensive Coverage:

- a. Glass Breakage;
- b. “Loss” caused by hitting a bird or animal; and

- c. “Loss” caused by falling objects or missiles.

However, you have the option of having glass breakage caused by a covered “auto’s” collision or overturn considered a “loss” under Collision Coverage.

**Glass Repair – Waiver of Deductible**

No deductible applies to glass breakage, if the glass is repaired rather than replaced.

**SECTION III – PHYSICAL DAMAGE COVERAGE**, Paragraph A.4.a. – **Transportation Expenses** is replaced by the following:

**a. Transportation Expenses**

We will pay up to \$200 per day to a maximum of \$1,500 for temporary transportation expense incurred by you because of the total theft of a covered “auto” that is a:

- (1) Private passenger;
- (2) Truck;
- (3) Pick-up truck;
- (4) Panel; or
- (5) Van

type vehicle under 20,000 lbs. of Gross Vehicle Weight. We will pay only for those covered “autos” for which you carry either Comprehensive or Specified Causes of Loss Coverage. We will pay for temporary transportation expenses incurred during the period beginning 48 hours after the theft and ending, regardless of the policy’s expiration, when the covered “auto” is returned to use or we pay for its “loss”.

**SECTION III – PHYSICAL DAMAGE COVERAGE,**  
Paragraph A.4.b. – **Loss of Use Expenses** is  
replaced by the following:

**b. Loss of Use Expenses – Hired, Rented,  
or Borrowed Automobiles**

We will pay expenses for which an  
“insured” becomes legally responsible to  
pay for loss of use of a vehicle hired,  
rented or borrowed without a driver under  
a written rental contract or agreement.  
We will pay for loss of use expenses, if  
caused by:

- (1) Other than Collision, only if the  
Declarations indicate that  
Comprehensive Coverage is provided  
for the vehicle withdrawn from  
service.
- (2) Specified Causes of Loss only if the  
Declarations indicate that Specified  
Causes of Loss Coverage is provided  
for the vehicle withdrawn from  
service.
- (3) Collision only if the Declarations  
indicate that Collision Coverage is  
provided for the vehicle withdrawn  
from service.

However, the most we will pay for any  
expenses for loss of use is \$200 per day, to a  
maximum of \$1,500.

**SECTION III – PHYSICAL DAMAGE COVERAGE,**  
Paragraph A.4.c. – **Non-Transportation Loss of Use  
Expenses** is added as follows:

**c. Non-Transportation Loss of Use  
Expenses**

We will pay up to \$2,000 for non-  
transportation expense incurred by you,  
because of “loss” to a covered “auto”, if  
caused by:

- (1) Other than Collision, only if the  
Declarations indicate that  
Comprehensive Coverage is provided  
for the “auto” withdrawn from service;

- (2) Specified Causes of Loss only if the  
Declarations indicate that Specified  
Causes of Loss Coverage is provided  
for the “auto” withdrawn from service;  
or
- (3) Collision only if the Declarations  
indicate that Collision Coverage is  
provided for the “auto” withdrawn  
from service.

**SECTION III – PHYSICAL DAMAGE COVERAGE,**  
Paragraph A.4.d. – **Airbag Coverage** is added as  
follows:

**d. Airbag Coverage**

We will pay for the cost to repair, replace,  
or reset an airbag that inflates for any  
reason other than as a result of a  
collision, if the Declarations indicate that  
the covered “auto” has Comprehensive  
Coverage or Specified Causes of Loss  
Coverage.

**SECTION III – PHYSICAL DAMAGE COVERAGE,**  
Paragraph A.4.e. – **Rental Reimbursement  
Coverage** is added as follows:

**e. Rental Reimbursement Coverage**

We will pay up to \$75 per day for rental  
reimbursement expenses incurred by you  
for the rental of an “auto” because of  
“loss” to a covered “auto” that is a:

- (1) Private Passenger;
- (2) Truck;
- (3) Pick-up truck;
- (4) Panel; or
- (5) Van

type vehicle under 20,000 lbs. of Gross  
Vehicle Weight. Payment applies in  
addition to the otherwise applicable  
amount of each coverage you have on a  
covered “auto”. No deductibles apply to  
this coverage.

- (1) We will pay only for those expenses incurred during the policy period beginning 24 hours after the "loss" and ending, regardless of the policy's expiration, with the lesser of the following number of days:
  - (a) The number of days reasonably required to repair or replace the covered "auto".
  - (b) 30 days.
- (2) This coverage does not apply while there are spare or reserve "autos" available to you for your operations.
- (3) The Rental Reimbursement Coverage described above does not apply to a covered "auto" that is described or designated as a covered "auto" on Rental Reimbursement Coverage Form CA 99 23.

**SECTION IV – BUSINESS AUTO CONDITIONS –** Paragraph B.2. – Concealment, Misrepresentation Or Fraud is amended by adding **Unintentional Failure to Disclose Hazards** at the end of Paragraph B.2. as follows:

**Unintentional Failure to Disclose Hazards**

If you unintentionally fail to disclose any hazards existing at the inception date of your policy, we will not deny coverage under this Coverage Form because of such failure. However, this provision does not affect our right to collect additional premium or exercise our right of cancellation or non-renewal.

This endorsement changes the policy to which it is attached and, unless otherwise stated, is effective on the date issued at 12:01 A.M. standard time at your mailing address shown in the policy. **The information below is required only when this endorsement is issued subsequent to commencement of the policy.**

Endorsement Effective 5/1/2017

Policy No. 17EPS08952

Insured WEMCO, Inc.

Endorsement No. 3

Countersigned By \_\_\_\_\_

**SECTION IV – BUSINESS AUTO CONDITIONS –** Paragraph B.5.b. – **Other Insurance** is replaced by the following:

- b. For Hired Auto Physical Damage Coverage, the following are deemed to be covered "autos" you own:
  - (1) Any covered "auto" you lease, hire, rent, or borrow; and
  - (2) Any covered "auto" hired or rented by your "employee" under a contract in that individual "employee's" name, with your permission, while performing duties related to the conduct of your business.

However, any "auto" that is leased, hired, rented or borrowed with a driver is not a covered "auto".

**SECTION V – DEFINITIONS –** Paragraph C. – **"Bodily injury"** is replaced by the following:

- C. "Bodily injury" means bodily injury, sickness or disease sustained by a person including death or mental anguish resulting from any of these. Mental anguish means any type of mental or emotional illness or disease

**Agenda Sheet for City Council:****Committee:** PIES **Date:** 10/21/2024**Committee Agenda type:** Consent**Date Rec'd**

10/22/2024

**Clerk's File #**

OPR 2024-0932

**Cross Ref #****Project #****Council Meeting Date:** 11/04/2024**Submitting Dept**

WATER &amp; HYDROELECTRIC SERVICES

**Bid #**

RFQ 6224-24

**Contact Name/Phone**

LOREN SEARL 509-625-7821

**Requisition #****Contact E-Mail**

LSEARL@SPOKANECITY.ORG

**Agenda Item Type**

Purchase w/o Contract

**Council Sponsor(s)**

BWILKERSON JBINGLE KKLITZKE

**Agenda Item Name**

4100 APPROVAL OF VALUE BLANKET ORDER FOR SERVICE TRUCK BODIES

**Agenda Wording**

Purchase of new truck bodies

**Summary (Background)**

Request for Quotes 6224-24 was opened and accepted bids until 9-5-24 for the supply of 2 service truck bodies. Titan Truck Equipment (Spokane Valley, WA) was the only responsive bidder with a total price of \$121,693.42

Lease? NO

Grant related? NO

Public Works? NO

**Fiscal Impact**

Approved in Current Year Budget? YES

Total Cost \$ 121,693.42

Current Year Cost \$ 121,693.42

Subsequent Year(s) Cost \$

**Narrative**

This purchase is for the service truck beds to be installed at the water department weld shop. Total assembled price is estimated to be lower than the historical price paid for outside shops to do this work.

**Amount****Budget Account**

Revenue \$ 121,693.42

# 4100-42490-94340-56401-11084

Select \$

#

Select \$

#

Select \$

#

\$

#

\$

#



## Committee Agenda Sheet

### Public Infrastructure, Environment & Sustainability Committee

<b>Committee Date</b>	10-21-24
<b>Submitting Department</b>	Water & Hydroelectric Services
<b>Contact Name</b>	Loren Searl
<b>Contact Email &amp; Phone</b>	<a href="mailto:lsearl@spokanecity.org">lsearl@spokanecity.org</a> 509-625-7821
<b>Council Sponsor(s)</b>	Wilkerson, Bingle, Klitzke
<b>Select Agenda Item Type</b>	<input checked="" type="checkbox"/> Consent <input type="checkbox"/> Discussion    Time Requested: Purchase w/o Contract
<b>Agenda Item Name</b>	4100 Approval of Value Blanket order for Service Truck Bodies
<b>Proposed Council Action</b>	<input checked="" type="checkbox"/> Approval to proceed to Legislative Agenda <input type="checkbox"/> Information Only
<b>Summary (Background)</b>	Request for Quotes 6224-24 was opened and accepted bids until 9-5-24 for the supply of 2 service truck bodies. Titan Truck Equipment was the only responsive bidder with a total price of \$121,693.42
*use the Fiscal Impact box below for relevant financial information	
<p><b>Fiscal Impact</b></p> <p><b>Approved in current year budget?</b>    <input checked="" type="checkbox"/> Yes    <input type="checkbox"/> No    <input type="checkbox"/> N/A</p> <p>Total Cost: <u>\$121,693.42</u></p> <p>Current year cost:</p> <p>Subsequent year(s) cost: \$0</p> <p><b>Narrative:</b> <u>This purchase is for the service truck beds to be installed at the water department weld shop. Total assembled price is estimated to be lower than the historical price paid for outside shops to do this work.</u></p> <p><b>Funding Source</b>    <input checked="" type="checkbox"/> One-time    <input type="checkbox"/> Recurring    <input type="checkbox"/> N/A</p> <p>Specify funding source: Program revenue</p> <p>Is this funding source sustainable for future years, months, etc? 4100-42490-94340-56401-11084</p> <p><b>Expense Occurrence</b>    <input checked="" type="checkbox"/> One-time    <input type="checkbox"/> Recurring    <input type="checkbox"/> N/A</p> <p>Other budget impacts: (revenue generating, match requirements, etc.)</p>	
<p><b>Operations Impacts (If N/A, please give a brief description as to why)</b></p> <ul style="list-style-type: none"> <li>• What impacts would the proposal have on historically excluded communities? Public works services and projects are designed to serve all citizens and businesses. We strive to offer a consistent level of service to all, to distribute public investment throughout the community and to respond to gaps in services identified in various City plans. We recognize the need to maintain affordability and predictability for utility customers and we are committed to delivering work that is both financially and environmentally responsible.</li> </ul>	

- How will data be collected, analyzed, and reported concerning the effect of the program/policy by racial, ethnic, gender identity, national origin, income level, disability, sexual orientation, or other existing disparities?

N/A

- How will data be collected regarding the effectiveness of this program, policy, or product to ensure it is the right solution?

Public Works follows the City's established procurement and public works bidding regulations and policies to bring items forward, and then uses contract management best practices to ensure desired outcomes and regulatory compliance.

- Describe how this proposal aligns with current City Policies, including the Comprehensive Plan, Sustainability Action Plan, Capital Improvement Program, Neighborhood Master Plans, Council Resolutions, and others?

This work is consistent with annual budget strategies to limit costs and approved projects in the 6-year CIP.

### **Council Subcommittee Review**

- Please provide a summary of council subcommittee review. If not reviewed by a council subcommittee, please explain why not.

## Bid Response Summary

**Bid Number** RFQ 6224-24  
**Bid Title** Dakota Bodies for 2024 F-750  
**Due Date** Thursday, September 5, 2024 1:00:00 PM [(UTC-08:00) Pacific Time (US & Canada)]  
**Bid Status** Closed to Bidding  
**Company** Titan Truck Equipment  
**Submitted By** Mike Alimane - Wednesday, September 4, 2024 10:53:10 AM [(UTC-08:00) Pacific Time (US & Canada)]  
 mikea@titantruck.com 5095345010

### Comments

### Question Responses

Group	Reference Number	Question	Response
Contact			
	1	Indicate the appropriate point of contact (phone number and email) regarding this quote and placement of order if awarded. If these actions will not be managed by the same person, explicitly specify all relevant contacts.	Mike Alimane Ph# (509) 534-5010 Ext-1120 Email: mikea@titantruck.com
Council Approval			
	1	Supplier acknowledges award of this business is subject to City Council approval, estimated the beginning of October 2024	I acknowledge and agree
General			
	1	Acceptable product makes/models, where specified, must be adhered to. In the absence of specified acceptable products, the listed technical specifications in each product category represent the minimum qualifications for acceptable product. The make/model of products bid may be required at bid submission; if so, the field will be indicated required on the 'Pricing' tab.	Understood and Agreed
	2	Estimated delivery timeline	20 Weeks
Product - Dakota Body			
	*	Quantity: two (2)	Yes
	1	Dakota Bodies 134"L x 48" H x 98" W Steel Canopy Body, City to do installation	I acknowledge
	BODY DIMENSIONS	58/48 inches - Compartment height, 22 inches - Compartment depth, 54 inches - Load space width, 40/30 inches - Top of body to the top of the floor, 24 inches - Horizontal compartment height, No wheel well boxes.	I acknowledge
	BODY MATERIALS	14 gauge galvaneal for Main body material, 12 gauge galvaneal for Compartemnt tops, 18 gauge galvaneal for Inner door panels, 16 gauge galvaneal for Outer door panels	I acknowledge
	BODY MATERIALS	5/16" Stainless Steel continuous rod for Door Hinge Rod Stainless Steel for Door Hinge Sockets. Center hinge blocks on All doors - Rain deflectors installed on leading edge of and over all doors. 14 gauge galvaneal for Wheel Pannels Shelving installed on DUAL Uni-Strut for infinite adjustment.	I acknowledge



BODY FLOOR AND UNDERSTRUCTURE	3/16 Hot Rolled Treadplate for Floor, 6" Structural steel channel frame, Crossmembers on 16" centers in 132" long cargo area.	I acknowledge
ACCESSORIES	Whale Tail Compression T-Handle door latches with DBI 3-point Roller Rods, Rollers Rods used on all doors (unless noted)	I acknowledge
ACCESSORIES	Gas cylinder type door holders on vertically hinged doors and chain stops on horizontal drop-down doors - Service Body Rubber rolled crown type fenders. (Installed with wheel cut-outs)	I acknowledge
ACCESSORIES	Automotive bulb type weatherstripping mechanically fastened to door frame with rounded corners - Master door lock, hook and loop system on each door with two (2) spring loaded door handles in the unlocked position.	I acknowledge
COMPARTMENT LIGHTING	Strip light compartment lights in all body compartments. Each compartment has individual rope lighting with Quick - Connects if individual sections are damaged or burned out. LED Strip Lighting	I acknowledge
PAINT	Prime only Paint. Install Rubberized undercoat under body. Install Raptor bedliner in cargo area including floor, sidewalls, and bulkhead. Primer only and undercoating.	I acknowledge
CARGO AREA	One (1) 110" row of E-Track on cargo wall streetside as high as possible. One (1) 110" row of E-Track on cargo wall Curbside as high as possible	I acknowledge
STREETSIDE COMPARTMENTATION	TOP 1ST VERTICLE: 28" Wide x 40" High x Transverse - Box wrapper & dividers made of 10 ga galvalneal. 3/4 angle door frame on 3 sides. No weatherstrip	I acknowledge
STREETSIDE COMPARTMENTATION	TOP 1ST VERTICLE: Sweep out bottom - Single panel, reinforced with hat sections. - Transverse compartment from streetside to Curbside. Does not need to be weatherproof.	Agree and acknowledge
STREETSIDE COMPARTMENTATION	TOP 1ST VERTICLE: Pigeon holes made of 10 ga galvalneal, recessed back 4" from doors. Center 28" is Pigeon hole shoring compartments with three spaces 9 1/8" (min) wide. (Clear opening) x six rows 6-5/8" (min) high. Bottom row has a double compartment (remove v divider) small pigeon hole to the rear.	Agree and acknowledge
STREETSIDE COMPARTMENTATION	BOTTOM 1ST VERTICAL: 28" Wide x 18" High x 22" Deep. Double Panel drop down door, Watertight personal compartment, one (1) adjustable plain shelf with 1" lip	I acknowledge
STREETSIDE COMPARTMENTATION	2ND VERTICLE: 26" Wide x 48" High x 22" Deep. This compartment used for storing heavy pipe fittings - Four (4) fixed PLAIN 12-gauge galvalneal shelves with 2" lips and hat section reinforcement.	I acknowledge

STREETSIDE COMPARTMENTATION	HORIZONTAL COMPARTMENT: 54" Wide x 24" High x 22" Deep. Single horizontal lift-up door w/gas struts, one adjustable plain shelf on Dual Uni-strut, Open compartment under shelf	I acknowledge
STREETSIDE COMPARTEMENTATION	REAR VERTICAL: 28" Wide x 48" High x 22" Deep. Single vertically hinged door, shelf lips turned down, water cask holder with drainage.	I acknowledge
CURBSIDE COMPARTEMENTATION	TOP 1ST VERTICAL: 28" Wide x 40" High x Transverse - Box wrapper & dividers made of 10 ga galvaneal, 3/4" angle door frame on 3 sides. No weatherstripping. Sweep out bottom - barn doors, single panel, reinforced with hat sections - Transverse compartment from streetside to curbside. This compartment does not need to be weather proof.	I acknowledge
CURBSIDE COMPARTEMENTATION	TOP FIRST VERTICAL: Pigeon holes made of 10 ga galvaneal, recessed back 4" from doors, compartment bottom on chassis frame. Center 28" is Pigeon hole shoring compartments with three spaces 9-1/8(min) wide. (clear opening) x six rows 6-5/8 (min) high. Bottom row has a double compartment (remove v divider) small pigeon hole to the rear.	I acknowledge and agree
CURBSIDE COMPARTEMENTATION	BOTTOM 1ST VERTICAL: 28" Wide x 20" High x 22" Deep. Double panel drop down door, Watertight personal compartment, One (1) adjustable plain shelf with 1" lip	I acknowledge
CURBSIDE COMPARTEMENTATION	2ND VERTICAL: 26" Wide x 48" High x 22" Deep. One (1) Adjustable Peg Rail at Compartment Top with thirty-one (31) 1/4" Pegs. Two (2) Plain Adjustable shelves on Dual Uni-Strut	I acknowledge
CURBSIDE COMPARTEMENTATION	HORIZONTAL COMPARTMENT: 54" Wide x 24" High x 22" Deep. Single horizontal lift-up door w/gas struts, One adjustable plain shelf on Dual Uni-strut. Open compartment under shelf.	I acknowledge
CURBSIDE COMPARTEMENTATION	REAR VERTICAL: 18" Wide x 48" High x 22" Deep. Single vertically hinged door. Sandpiper Pump storage 22"Lx 24" H x 18" W Approximately 150 lbs., Slidemaster 300 lbs. capacity 70% extension SM2-LP Steel Powder coated Black, no tray, locks open and closed.	I acknowledge
CURBSIDE COMPARTEMENTATION	REAR VERTICAL: Dakota bodies to build 21" x 18" tray 12 ga galvanized with 1" lip up on all 4 sides and bolt to slidemaster. Sweep out bottom formed frame - Bottom of frame flush with bottom of wrapper	I acknowledge

CURBSIDE COMPARTEMENTATION	REAR LIGHTING: Light boxes installed on rear of body - Position to be determined. Rubber mounted recessed rear lighting kit with harness - Installed, two (2) stop/tail/turn lights, Peterson brand M826R-7 LED. Two (2) clear back up lights, Peterson brand M826C-7 LED	I acknowledge
CURBSIDE COMPARTEMENTATION	REAR LIGHTING: Two (2) Amber front 3/4" button style clearance lights, Tec Niq 533-AA9B-1, wire front clearance lights to rear clearance lights. Two (2) red side 3/4" button style clearance lights, Tec Niq S33-RR0B-1. Two (2) red rear 3/4" button style clearance lights - Tec Niq S33-RR0B-1. Three (3) light center cluster 3/4" button style, Tec Niq S33-RR0B-1. 7-Lanm light wiring Harness	I acknowledge
SUPERSTRUCTURE	SUPERSTRUCTURE: Not to exceed 11'-0" travel height, Calculated 10'-10" travel with chassis frame height at 41" above level ground. 134" Long x 88" wide x 35"/47" Height 14-gauge galvanized superstructure sides and top.	I acknowledge
SUPERSTRUCTURE	SUPERSTRUCTURE: Superstructure sides are recessed 5" on each side for ladder storage. Ladders are 120" Lx4" x 17" W. Minimum interior clearance 77" (6'-5"). Maxxima M84417 Surface Mount cargo Light with a push/pull switch.	I acknowledge
LADDER BRACKETS	Ladder Brackets ship loose: Four (4) Rubberized ladder brackets 21" Tall x 3" Wide x 6 1/2" Depth. To be bolted on the exterior of the superstructure by the customer.	I acknowledge
STREETSIDE	STREETSIDE: Hose reel for 1/2" airline 75 feet. Cox Reel TSH-N-475. MFG P/N: TSH-N-475 Coxreels 1/2" i.D., 27/32" O.D., 75ft hose. 300 psi rating.	I acknowledge
CURBSIDE	CURBSIDE: Key Storage Four (4) 4 1/2" high x 4 1/2" pigeon holes x 108" Long side by side on top of that Curbside compartments. Incorporate a 1 1/2" ID x 108" long (think wall tube or pigeon hole) storage for air blower house. Vertical dividers at rear body to keep key handles vertical. 2" UHMV strip to hold handles away from rear compartment. Pendulum style horizontal bar at rear with retaining pin to keep keys in rack.	I acknowledge
ALUMINUM ROLL-UP DOOR	Aluminum Roll-up Door installed at rear of superstructure: minimum clear opening of 72" High x 50" Wide, Manual security Lock, Sill Plate with Dam, Pull strap, Brushed Texture Finish	I acknowledge and agree

EXTERIOR LIGHTING	Supply & install six (6) Whelen series 900 scene lights, Two (2) on rear, Two (2) on each side on exterior. - One Arrow Stick mounting bracket 2" above Rear of superstructure for customer supplied Arrow stick. - Add Formed 16 ga galvaneal wire chases around interior perimeter of superstructure.	I acknowledge
SAFETY LIGHTING	Supply and install six (6) Ecco model 3811A clear amber strobe lights. - Two (2) Installed on each side of the body and Two (2) installed at the rear of the body.	I acknowledge
PLYWOOD/SHORING STORAGE (Weld On)	Floor is 3/16" hr treadplate installed at chassis frame, 1" square tube frame to protect cab from plywood, UHMV Roller and chain with dog clip retainer. (Board storage is directly behind the cab with access from both sides of the body) - Paint is the same as body.	I acknowledge
2	Must either be in stock or in production with an expected delivery date no more than 60 days out.	I do not understand and I do not agree
3	Other optional specifications will be considered on a case-by-case basis.	I understand and I agree
4	Upload your spec sheets and quote for what you are bidding here. You will only be allowed to upload one document so if you have multiple pages, save them as one document before you upload. There will be multiple upload lines available if you are bidding multiple different options.	City of Spokane Dakota Bodies 11'ft Steel Canopy Body Updated Quote 8-1-2024.pdf
5	Upload your spec sheets and quote for what you are bidding here. You will only be allowed to upload one document so if you have multiple pages, save them as one document before you upload. There will be multiple upload lines available if you are bidding multiple different options.	City of Spokane Dakota Bodies 11'ft Steel Canopy Body Updated Quote 8-1-2024.pdf
6	Upload your spec sheets and quote for what you are bidding here. You will only be allowed to upload one document so if you have multiple pages, save them as one document before you upload. There will be multiple upload lines available if you are bidding multiple different options.	City of Spokane Dakota Bodies 11'ft Steel Canopy Body Updated Quote 8-1-2024.pdf
7	Upload your spec sheets and quote for what you are bidding here. You will only be allowed to upload one document so if you have multiple pages, save them as one document before you upload. There will be multiple upload lines available if you are bidding multiple different options.	City of Spokane Dakota Bodies 11'ft Steel Canopy Body Updated Quote 8-1-2024.pdf

STREETSIDE	STREETSIDE: The hose supplied with these reels is designed for air or water use only. Hose included. Two (2) fixed shelves installed over compartment top forward of the hose reels. Standard rope light (3/8" LED 1" on center" compartment lights installed under each shelf in superstructure. 2" Lips full length each side of body tops for using tops as shelves.	I acknowledge
CURBSIDE:	CURBSIDE: Access panels inside superstructure midway and forward of pigeon holes for cleanout. Hose reel for 3/4" airline 75 feet. MFG P/N: TSH-N-575 Coxreels 3/4" I.D., 1-5/32" O.D., 75ft hose .300 rating. The hose supplied with these reels is designated for air or water use only. Hose to be included.	I acknowledge
CURBSIDE:	CURBSIDE: 2" Lips full length each side of body tops for using tops as shelves. two (2) fixed shelves installed over compartment top forward of the hose reels. LED strip lighting compartment lights installed under each shelf in superstructure. 10" high punched rail over 1st vertical compartment top.	I acknowledge
Delivery		
1	All freight expenses shall be the responsibility of the winning supplier. Unit pricing on this quote is understood to include delivery to the FOB point.	Understood and Agreed
2	All products shall be ordered/delivered FOB: Destination 914 E N Foothills Dr Spokane WA 99207	Understood and Agreed
Additional Items		
1	The City of Spokane reserves the right to purchase additional items at the quoted price. Supplier agrees to sell at the same price, terms, and conditions.	Yes
Payment Terms		
1	Supplier agrees payment shall be made via direct deposit/ACH (except as provided by state law or if paid by credit card) according to net30 terms after receipt of goods ordered. A completed ACH application is required (if not already on file) before a City order will be issued. If the City objects to all or any portion of an invoice, it shall notify the supplier and reserve the right to pay only that portion of the invoice not in dispute. In that event, all parties shall immediate make every effort to settle the disputed amount.	Understood and Agreed
2	Supplier agrees to accept Visa credit card payment at no additional fee.	Yes
Sales Tax		

1	The City of Spokane is not a tax exempt entity and is therefore obligated to pay sales tax under Washington State law. Sales tax should not be included in respondent's pricing. All submissions shall be tabulated with the applicable sales tax rate whether that tax shall be charged through the supplier or paid by the City as use tax.	Understood and Agreed
Business Registration Requirement		
1	Section 8.01.070 of the Spokane Municipal Code states that no person may engage in business with the City without first having obtained and being the holder of a valid annual business registration or temporary business registration as provided in this chapter. The supplier shall be responsible for contacting the State of Washington Business License Services at <a href="http://www.dor.wa.gov">www.dor.wa.gov</a> or 360-705-6741 to obtain a business registration. If the supplier does not believe it is required to obtain a business registration, it may contact the City's Taxes and Licenses Division at 509-625-6070 to request an exemption status determination.	Understood and Agreed
2	Supplier's Business Registration No.	T12004305BUS
Polychlorinated Biphenyls (PCBs)		
1	In accordance with SMC 7.06.172(A), respondent certifies the products quoted and to be supplied (to include product packaging) do not contain polychlorinated biphenyls (PCBs). Moreover and consistent with SMC 7.06.172(B), the City of Spokane, at its sole discretion, may require (at no cost to the City) the apparent successful respondent to provide testing data (prior to contract execution or issue of purchase order) from an accredited laboratory or testing facility documenting the proposed products and or product packaging polychlorinated biphenyl levels.	Understood and Agreed
2	As far as you know, has this product type been tested for PCBs by a WA State accredited lab using EPA Method 1668c (or equivalent as updated)?	Yes
3	If so, were PCBs found at a measurable level?	No
4	As far as you know, has this actual product been tested for PCBs by a WA State accredited lab using EPA Method 1668 (or equivalent as updated)?	No
5	If so, note from whom the results can be obtained.	
6	Do you have reason to believe the product contains measurable levels of PCBs?	No

7	Do you have reason to believe the product packaging contains measurable levels of PCBs?	No
Terms & Conditions		
1	Submission of a bid constitutes acceptance of the Terms & Conditions of this request in accordance with the document so named in the 'Documents' tab.	Understood and Agreed

**Pricing Responses**

Group	Reference Number	Description	Type	Unit Of Measure	Quantity	Unit Price	Ext Base Price	Comment	Make/Model
Product	-	Dakota Body							
	1	Dakota Body	Base	ea	2.00	\$55,822.67	\$111,645.34		
	2.	Freight	Base	ea	1.00	\$0.00	\$0.00		
<b>Total Base Bid</b>		\$111,645.34							

**Titan Truck Equipment Co., Inc.**

605 N. Fancher Rd.  
Spokane Valley, WA 99212  
(509) 534-5010  
Toll Free: 1-800-445-4807  
Equipment Fax: (509) 755-5040



**Quote # TTQ812024-1**

Quote valid for 30 days  
Quote Date: 8/19/2024

Quote Provided by:

**Mike Alimane**  
Equipment/Aerial Sales  
Phone: 509-534-5010 Ext-1120  
Email: mikea@titantruck.com

**Customer Information**

**Vehicle Information**

**Special Instructions**

City of Spokane  
Spokane, WA  
Contact Name: Scott  
End User:

2024 Ford F-750  
DRW 4x4, 84" CA, GVW  
VIN #  
Condition: New

Prices subject to change based upon manufacturer price surcharge increases. Price increases from manufacturer will be added to this quote if applicable. Price increases will be backed with manufacturer documentation,

Qty	Item Description	Part Number	Serial Number	Part Charge	Exended Charge	HRS	Labor Charge	*Estimated* Freight Charges	Itemized Total
1	Customer to Install Dakota Body			\$ -	\$ -		\$ -	\$ -	\$ -
1	Dakota Bodies 134"L x 48"H x 98"W Steel Canopy Body - Freight is an Estimate and the Current Lead Time is Approx.. 16 - 18 Weeks and is Subject to Change	DAKOTQ47080B		51,822.67	51,822.67		-	\$ 4,000.00	\$ 55,822.67
1	Body Dimensions: 58/48 Inches - Compartment height, 22 Inches - Compartment depth, 54 Inches - Load space width, 40/ 30 Inches - Top of body to the top of the floor, 24 Inches - Horizontal compartment height, No Wheel well boxes			-	-		-		\$ -
1	Body Materials: 14 gauge galvanized. - Main body material 12 gauge galvanized. - Compartment tops 18 gauge galvanized - Inner door panels 16 gauge galvanized - Outer door panels - 5/16" Stainless Steel continuous rod - Door Hinge Rod. - Stainless Steel - Door Hinge Sockets. Center hinge blocks on ALL doors - Rain deflectors installed on leading edge of and over all doors. 14 gauge galvanized - Wheel Panels Shelving installed on DUAL Uni-Strut for infinite adjustment			-	-		-		\$ -
1	Body Floor and Understructure: 3/16 Hot Rolled Treadplate - Floor 6" Structural steel channel frame, Crossmembers on 16" centers in 132" long cargo area.			-	-		-		\$ -
1	Accessories: - Whale Tail Compression T-Handle door latches with DBI 3 point Roller Rods, Rollers Rods used on all doors (Unless Noted) - Gas cylinder type door holders on vertically hinged doors and chain stops on horizontal drop down doors - Service Body Rubber rolled crown type fenders. (Installed with wheel cut-outs) - Automotive bulb type weatherstripping mechanically fastened to door frame with rounded corners - Master door lock, hook and loop system on each door with two (2) spring loaded door handles in the unlocked position			-	-		-		\$ -



1	<p>Compartment Lighting:  <b>strip light compartment lights in all body compartments.</b> Each compartment has individual rope lighting with Quick - Connects if individual sections are damaged or burned out</p>	LED	LED Strip Lighting	-	-	-	-	\$	-
1	<p>Paint:  - <b>Prime only paint</b>  - Install Rubberized undercoat under body. Install Raptor bedliner in cargo area including floor, sidewalls, &amp; bulkhead</p>		Primer Only and Undercoating	-	-	-	-	\$	-
1	<p>Cargo Area:  - One (1) 110" row of E-Track on cargo wall Streetside as high as possible.  - One (1) 110" row of E-Track on cargo wall Curbside as high as possible</p>			-	-	-	-	\$	-
1				-	-	-	-	\$	-
1	<p><b>Streetside Compartmentation</b>  Top 1st Vertical:  28" Wide x 40" High x Transverse  - Box wrapper &amp; dividers made of 10 ga galvalneal. 3/4" angle door frame on 3 sides. No weatherstrip.  - Sweep out bottom.  - SINGLE door, single panel, reinforced with hat sections.  - Transverse compartment from Streetside to Curbside. This compartment will NOT be weather proof.  - Pigeon holes made of 10 ga galvalneal, recessed back 4" from doors. See sketch  Center 28" is Pigeon hole shoring compartments with three spaces 9-1/8" (min) wide  (Clear opening) x six rows 6-5/8" (min) high  - Bottom row has a double compartment (remove v divider) small pigeon hole to the rear.</p>			-	-	-	-	\$	-
1	<p>Bottom 1st Vertical:  28" Wide x 18" High x 22" Deep  - Double panel drop down door  - Water tight personel compartment.  - One (1) adjustable plain shelf with 1" lip</p>			-	-	-	-	\$	-
1	<p>2nd Vertical:  26" Wide x 48" High x 22" Deep  This compartment used for storing heavy pipe fittings  - Four (4) fixed PLAIN 12 gauge galvalneal shelves with 2" lips and hat section reinforcement</p>			-	-	-	-	\$	-
1	<p>Horizontal Compartment:  54" Wide x 24" High x 22" Deep  - <b>Single horizontal lift-up door w/gas struts</b>  - One adjustable plain shelf on Dual Uni-strut.  - Open compartment under shelf</p>		Lift-up Doors	-	-	-	-	\$	-
1	<p>Rear Vertical:  28" Wide x 48" High x 22" Deep  - Single vertically hinged door.  - Shelf Lips Turned Down  - Water Cask holder with drainage</p>			-	-	-	-	\$	-



1	<p>Superstructure:  Not to Exceed 11'-0" travel height, Calculated 10'-10" travel with chassis frame height at 41" above level ground.  134" Long x 88" wide x 35"/47" High 14 gauge galvaneal superstructure sides and top .  Superstructure sides are recessed 5" on each side for ladder storage.  Ladders are 120" L x 4" x 17" W  Minimum interior clearance 77" (6'-5")  - Maxxima M84417 Surface Mount Cargo Light With a Push/Pull Switch</p>								\$	-
1	<p>Ladder Brackets: Ship Loose  - Four (4) Rubberized ladder brackets 21" Tall x 3" Wide x 6 1/2" Depth  - Bolted on the exterior of the superstructure by Customer.</p>								\$	-
1	<p>Streetside:  <b>Hose reel for 1/2" airline 75 feet. Cox Reel TSH-N-475</b>  - MFG P/N: TSH-N-475 Coxreels 1/2" I.D., 27/32" O.D., 75 ft hose. 300 PSI rating.  - The hose supplied with these reels is designed for air or water use only. Hose included.  - Two (2) fixed shelves installed over compartment top forward of the hose reels.  - Standard rope light (3/8" L.E.D. 1" on center) compartment lights installed under each shelf in superstructure  - 2" Lips full length each side of body tops for using tops as shelves.</p>	Need 1/2" Hose Reel on Street Side							\$	-
1	<p>Curbside:  - Key Storage Four (4) 4 1/2" high x 4 1/2" pigeon holes x 108" Long side by side on top of the  Curbside compartments  - Incorporate a 1 1/2" ID x 108" Long (thin wall tube or pigeon hole) storage for air blower hose.  - Vertical dividers at rear of body to keep key handles vertical.  - 2" UHMV strip to hold handles away from rear compartment.  - Pendulum style horizontal bar at rear with retaining pin to keep keys in rack.  - Access panels inside superstructure midway and forward of pigeon holes for cleanout.  <b>Hose reel for 3/4" airline 75 feet.</b>  - MFG P/N: TSH-N-575 Coxreels 3/4" I.D., 1-5/32" O.D., 75 ft hose .300 PSI rating.  - The hose supplied with these reels is designed for air or water use only. Hose included.  - 2" Lips full length each side of body tops for using tops as shelves.  - Two (2) fixed shelves installed over compartment top forward of the hose reels.  - LED strip lighting compartment lights installed under each shelf in superstructure  - 10" high punched rail over 1st vertical compartment top.</p>	Need 3/4" Hose Reel on Curb Side							\$	-

1	Aluminum Roll-up Door installed at rear of superstructure - minimum clear opening of 72" High x 50" Wide - Manual Security Lock - Sill Plate with Dam - Pull Strap - Brushed Texture Finish								\$ -
1	Exterior Lighting: - Supply & Install Six (6) Whelen series 900 scene lights, Two (2) on rear, Two (2) on each side on exterior - One Arrow Stick mounting bracket 2" above Rear of superstructure for customer supplied Arrow Stick. - Add Formed 16ga galvalneal wire chases around interior perimeter of superstructure								\$ -
1	Safety Lighting: Supply and install Six (6) Ecco model 3811A clear amber strobe lights. - Two (2) installed on each side of the body - Two (2) installed at the rear of the body								\$ -
1	Plywood/Shoring Storage: (Weld on) - Floor is 3/16" hr treadplate installed at chassis frame - 1" square tube frame to protect cab from plywood - UHMV Roller and chain with dog clip retainer (Board storage is directly behind the cab with access from both sides of the body) - Paint the same as body								\$ -
1	Rev A: 6/27/2024 (DJA) - Changed Compartment lighting from LED rope to LED strip - Changed Paint from Powdercoat to body prime only - Removed Copper Line and Hammer Storage - Swapped Hose reel configurations Rev B 7/8/2024 JRH - Horizontal doors lift-up ILO drop-down doors - Add plywood/shoring storage - Add angle boxes to the Whelen 900 scene lights								\$ -
1									\$ -
1									\$ -
1									\$ -
Subtotals			\$ 51,822.67	\$ 51,822.67	0.00	\$ -	\$ 4,000.00	\$ 55,822.67	
ALL PRICING IS LESS ANY APPLICABLE TAX CHARGES UNLESS OTHERWISE NOTED.						CASH,	rate per hr	Quote Total	\$ 55,822.67
CREDIT, OR CERTIFIED CHECK ARE THE ONLY PAYMENT METHODS CURRENTLY ACCEPTED.							\$ 119.00		

RFQ 6224-24				
DAKOTA BODIES 202R F-750				
	Description	Type	Quantity	Titan Truck Equipment
			ARO	20 WEEKS
1 DAKOTQ470808	Dakota Body	Base	2	\$111,645.34
	2 Freight	Base	1	\$0.00
Sales Tax 9%				\$10,048.08
				\$121,693.42



**Agenda Sheet for City Council:**

**Committee:** PIES **Date:** 10/21/2024

**Committee Agenda type:** Consent

**Date Rec'd** 10/22/2024

**Clerk's File #** OPR 2024-0933

**Cross Ref #**

**Project #**

**Council Meeting Date:** 11/04/2024

**Submitting Dept** WATER & HYDROELECTRIC SERVICES

**Bid #** RFQ 6230-24

**Contact Name/Phone** LOREN SEARL 509-625-7821

**Requisition #**

**Contact E-Mail** LSEARL@SPOKANECITY.ORG

**Agenda Item Type** Purchase w/o Contract

**Council Sponsor(s)** BWILKERSON JBINGLE KKLITZKE

**Agenda Item Name** 4100 APPROVAL OF MISCELLANEOUS WATER PRODUCTS – PLAINS BOOSTER

**Agenda Wording**

Water Department purchase for the supply of miscellaneous water product fittings for Plains booster station

**Summary (Background)**

Request for Quotes 6230-24 was opened and accepted bids until 9-20-24 for the supply of miscellaneous water product fittings for connections to the new West Plains Booster Station project. Three bids were received with lowest Responsive bidder being Core & Main (Spokane Valley, WA) for a total cost of \$177,300.46

Lease? NO Grant related? NO Public Works? NO

**Fiscal Impact**

Approved in Current Year Budget? YES

Total Cost \$ 177,300.46

Current Year Cost \$ 177,300.46

Subsequent Year(s) Cost \$

**Narrative**

This purchase is for the fittings to connect the new west plains booster station project to our water system.

**Amount**

**Budget Account**

Revenue \$ 177,300.46 # 4250 98818 94340 56501 15799

Select \$ #

Select \$ #

Select \$ #

\$ #

\$ #



## Committee Agenda Sheet

### Public Infrastructure, Environment & Sustainability Committee

<b>Committee Date</b>	10-21-24
<b>Submitting Department</b>	Water & Hydroelectric Services
<b>Contact Name</b>	Loren Searl
<b>Contact Email &amp; Phone</b>	<a href="mailto:lsearl@spokanecity.org">lsearl@spokanecity.org</a> 509-625-7821
<b>Council Sponsor(s)</b>	Wilkerson, Bingle, Klitzke
<b>Select Agenda Item Type</b>	<input checked="" type="checkbox"/> Consent <input type="checkbox"/> Discussion    Time Requested: Purchase w/o Contract
<b>Agenda Item Name</b>	4100 Approval of Miscellaneous Water Products – Plains Booster
<b>Proposed Council Action</b>	<input checked="" type="checkbox"/> Approval to proceed to Legislative Agenda <input type="checkbox"/> Information Only
<b>Summary (Background)</b>	Request for Quotes 6230-24 was opened and accepted bids until 9-20-24 for the supply of miscellaneous water product fittings for connections to the new West Plains Booster Station project. Three bids were received with lowest Responsive bidder being Core & Main for a total cost of \$177,300.46
*use the Fiscal Impact box below for relevant financial information	
<p><b>Fiscal Impact</b></p> <p><b>Approved in current year budget?</b>    <input checked="" type="checkbox"/> Yes    <input type="checkbox"/> No    <input type="checkbox"/> N/A</p> <p>Total Cost: <u>\$177,300.46</u></p> <p>Current year cost:</p> <p>Subsequent year(s) cost: \$0</p> <p><b>Narrative:</b> <u>This purchase is for the fittings to connect the new west plains booster station project to our water system.</u></p> <p><b>Funding Source</b>    <input checked="" type="checkbox"/> One-time    <input type="checkbox"/> Recurring    <input type="checkbox"/> N/A</p> <p>Specify funding source: Program revenue</p> <p>Is this funding source sustainable for future years, months, etc? 4250 98818 94340 56501 15799</p> <p><b>Expense Occurrence</b>    <input checked="" type="checkbox"/> One-time    <input type="checkbox"/> Recurring    <input type="checkbox"/> N/A</p> <p>Other budget impacts: (revenue generating, match requirements, etc.)</p>	
<p><b>Operations Impacts (If N/A, please give a brief description as to why)</b></p> <ul style="list-style-type: none"> <li>What impacts would the proposal have on historically excluded communities? Public works services and projects are designed to serve all citizens and businesses. We strive to offer a consistent level of service to all, to distribute public investment throughout the community and to respond to gaps in services identified in various City plans. We recognize the need to maintain affordability and predictability for utility customers and we are committed to delivering work that is both financially and environmentally responsible.</li> </ul>	



- How will data be collected, analyzed, and reported concerning the effect of the program/policy by racial, ethnic, gender identity, national origin, income level, disability, sexual orientation, or other existing disparities?

N/A

- How will data be collected regarding the effectiveness of this program, policy, or product to ensure it is the right solution?

Public Works follows the City's established procurement and public works bidding regulations and policies to bring items forward, and then uses contract management best practices to ensure desired outcomes and regulatory compliance.

- Describe how this proposal aligns with current City Policies, including the Comprehensive Plan, Sustainability Action Plan, Capital Improvement Program, Neighborhood Master Plans, Council Resolutions, and others?

This work is consistent with annual budget strategies to limit costs and approved projects in the 6-year CIP.

### **Council Subcommittee Review**

- Please provide a summary of council subcommittee review. If not reviewed by a council subcommittee, please explain why not.

## Bid Response Summary

**Bid Number** RFQ 6230-24  
**Bid Title** Miscellaneous Waterworks Products - Plains Booster Station  
**Due Date** Friday, September 20, 2024 1:00:00 PM [(UTC-08:00) Pacific Time (US & Canada)]  
**Bid Status** Closed to Bidding  
**Company** Core & Main  
**Submitted By** Kevin Hoglund - Thursday, September 19, 2024 1:58:58 PM [(UTC-08:00) Pacific Time (US & Canada)]  
 kevin.hoglund@coreandmain.com 509-893-1055

### Comments

### Question Responses

Group	Reference Number	Question	Response
Contact			
	1	Indicate the appropriate point of contact (phone number and email) regarding this quote and placement of order if awarded. If these actions will not be managed by the same person, explicitly specify all relevant contacts.	Kevin Hoglund/ 509-590-5397 / kevin.hoglund@coreandmain.com
Council Approval			
	1	This purchase is subject to City Council approval. Approval is anticipated in October 2024. The City assumes no obligation to purchase until the purchase is approved by Council and a City purchase order is issued.	Understood and Agreed
General			
	1	Acceptable product makes/models, where specified, must be adhered to. In the absence of specified acceptable products, the listed technical specifications in each product category represent the minimum qualifications for acceptable product. The make/model of products bid may be required at bid submission; if so, the field will be indicated required on the 'Pricing' tab.	Understood and Agreed

3	Quoted lead times will be considered in award determinations for each category and may supersede lowest unit cost. Where lead times are the same or similar, the lowest responsive, responsible bidder shall prevail.	Understood and Agreed
4.	Supplier acknowledges delivery of all products within the following number of business days ARO:	I acknowledge and agree
Award of Contract		
1	Award of contract or purchase, when made, will be to the Bidder whose Quote/Bid is the most favorable to the Purchaser, taking into consideration price and the other evaluation factors. INTERLOCAL AND STATE CONTRACTS WHERE APPLICABLE WILL BE CONSIDERED AS A QUOTE/BID. Any order resulting from award will be submitted by Purchasing. Unsuccessful Bidders will not automatically be notified of Quote/Bid results.	I agree
Product - Ductile Iron Fittings		
1	All ductile iron fittings must be compact style, provided without accessories, and meet ANSI/AWWA C153/A21.53-11 standards. Full body fittings meeting ANSI/AWWA C110/A21.10-12 standards are acceptable only when a requested fitting is not covered by the C153 standard.	Understood and Agreed
2	Stainless steel bolts and nuts to be 316 stainless steel.	Understood and Agree
Product - Pipe: Ductile Iron - Tyton Joint		
1	All ductile iron pipe (City #P1300) is to be provided in 18' nominal lengths, cement lined, and manufactured in accordance with ANSI/AWWA C151/A21.51-17.	I agree

2	4" pipe (City #P1300) must be Thickness Class 52 or above. All other sizes must be Thickness Class 50 or above.	I agree
3	All pipe (City #P1300) quoted and supplied must incorporate the Tyton Joint design.	I agree
4	No more than two (2) truckloads of this pipe (across all sizes) may be delivered per day.	I agree
5	As this product (City #P1300) is inventoried and consumed by the City in whole feet, additional fractions of feet on physical rolls delivered will be received by the City at no additional charge.	I agree
6	Acceptable manufacturers for ductile iron pipe (City #P1300) are: McWane Ductile, and United States Pipe and Foundry ONLY.	I agree
Product - Gaskets		
1	Acceptable products for Tyton Joint Restraint Gaskets (City #G1000) are: US Pipe Field Lok, Gripper Gasket, or McWane SureStop ONLY.	I agree
ASI		
1	Supplier agrees to the American Iron and Steel Provision in the ASI Requirements Document in the Documents Tab	I acknowledge and agree
BABA		
1	Supplier agrees to the Build America/Buy America Requirements as stated in the BABA Specifications in the documents tab	I acknowledge and agree
2	Attach the filled out and signed form 350-110 located in the documents tab: WSDOT BABA Form 350-110	WSDOT BABA Form 350-110.pdf
3	Attach the filled out and signed form 350-109 located in the documents tab: WSDOT Steel Form 350-109	WSDOT Steel Form 350-109.pdf
Delivery		
1	All freight expenses shall be the responsibility of the winning supplier. Unit pricing on this quote is understood to include delivery to the FOB point.	I agree

2	All product shall be ordered/delivered FOB: Destination to 914 E. North Foothills Dr. Spokane, WA 99207.	I agree
3	Partial deliveries shall be accepted and any delivery delays must be communicated to the City employee who placed the order *before* the anticipated delivery date. Supplier is responsible for ensuring all deliveries meet promised timelines and for any resulting expenses, such as expedited freight costs.	I agree
4	Individual items are to be packaged in separate boxes clearly marked as to the type and quantity of enclosed item. Boxed items are to be delivered on pallets.	I agree
5	Whenever possible, product shall be delivered on Tuesdays, Wednesdays, or Thursdays. When delivery dates are specified, the supplier shall make every possible effort to deliver on the requested date or at least on the preferred delivery days in the same week. If product with a specific delivery date will be delayed more than one (1) week, supplier shall be responsible for communicating an updated delivery date to the Purchaser.	Understood and Agreed
6	The Purchaser's Warehouse is open for deliveries between the hours of 8:00am and 3:00pm on all regular business days (closed weekends).	I agree
7	All orders must be completed and delivered in full by December 01, 2024.	I agree
Additional Items		
1	The City of Spokane reserves the right to purchase additional items at the quoted price. Supplier agrees to sell at the same price, terms, and conditions.	I do not agree
Payment Terms		

1	Supplier agrees payment shall be made via direct deposit/ACH (except as provided by state law or if paid by credit card) according to net30 terms after receipt of goods ordered. A completed ACH application is required (if not already on file) before a City order will be issued. If the City objects to all or any portion of an invoice, it shall notify the supplier and reserve the right to pay only that portion of the invoice not in dispute. In that event, all parties shall immediate make every effort to settle the disputed amount.	I agree
2	Supplier agrees to accept Visa credit card payment at no additional fee.	I do not agree
Sales Tax		
1	The City of Spokane is not a tax exempt entity and is therefore obligated to pay sales tax under Washington State law. Sales tax should not be included in respondent's pricing. All submissions shall be tabulated with the applicable sales tax rate whether that tax shall be charged through the supplier or paid by the City as use tax.	I agree
Business Registration Requirement		

1	<p>Section 8.01.070 of the Spokane Municipal Code states that no person may engage in business with the City without first having obtained and being the holder of a valid annual business registration or temporary business registration as provided in this chapter. The supplier shall be responsible for contacting the State of Washington Business License Services at <a href="http://bls.dor.wa.gov">http://bls.dor.wa.gov</a> or 1-800-451-7985 to obtain a business registration. If the supplier does not believe it is required to obtain a business registration, it may contact the City's Taxes and Licenses Division at 509-625-6070 to request an exemption status determination.</p>	Understood and Agreed
2	Supplier's Business Registration No.	T1205100BUS
Proprietary Information/Public Disclosure		

Materials submitted in response to this competitive procurement shall become the property of the City. All received Proposals shall remain confidential until the award of contract recommendation has been filed with the applicable Council Committee or the City Clerk for City Council action. Thereafter, the Proposals shall be deemed public records as defined in RCW 42.56, "Public Records." Any information in the Proposal that the Proposer desires to claim as proprietary and thus exempt from disclosure under the provisions of existing state law, shall be clearly designated. Each page claimed to be exempt from disclosure must be clearly identified by the word "Confidential" printed on it. Marking the entire Proposal exempt from disclosure will not be honored. The City will consider a Proposer's request for exemption from disclosure; however, the City will make a decision predicated upon state law and regulations. If any information is marked as proprietary in the Proposal, it will not be made available until the affected Proposer has been given an opportunity to seek a court injunction against the requested disclosure.

1.

I agree

Polychlorinated  
Biphenyls (PCBs)



1	<p>In accordance with SMC 7.06.172(A), respondent certifies the products quoted and to be supplied (to include product packaging) do not contain polychlorinated biphenyls (PCBs). Moreover and consistent with SMC 7.06.172(B), the City of Spokane, at its sole discretion, may require (at no cost to the City) the apparent successful respondent to provide testing data (prior to contract execution or issue of purchase order) from an accredited laboratory or testing facility documenting the proposed products and or product packaging polychlorinated biphenyl levels.</p>	Understood and Agreed
2	<p>As far as you know, has this product type been tested for PCBs by a WA State accredited lab using EPA Method 1668c (or equivalent as updated)?</p>	No
3	<p>If so, were PCBs found at a measurable level?</p>	No
4	<p>As far as you know, has this actual product been tested for PCBs by a WA State accredited lab using EPA Method 1668 (or equivalent as updated)?</p>	No
5	<p>If so, note from whom the results can be obtained.</p>	
6	<p>Do you have reason to believe the product contains measurable levels of PCBs?</p>	No
7	<p>Do you have reason to believe the product packaging contains measurable levels of PCBs?</p>	No
Interlocal Purchase Agreements		

	1.	The City of Spokane has entered into Interlocal Purchase Agreements with other public agencies pursuant to chapter 39.34 RCW. In submitting a response, the Proposer agrees to provide its services to other public agencies at the same contracted price, terms and conditions it is providing to the City of Spokane, contingent upon the Firm's review and approval at the time of a requested contract. . The Firm's right to refuse to enter into a contract with another public agency at the time of request shall be absolute.	I do not agree
Terms & Conditions			
	1	Submission of a bid constitutes acceptance of the Terms & Conditions of this request in accordance with the document so named in the 'Documents' tab.	I agree

### Pricing Responses

Group	Reference Number	Description	Type	Unit Of Measure	Quantity	Unit Price	Ext Base Price	Comment	Make/Model
Product									
	1. CITY #C1344-24-D	24" MJ CAP TAPPED DI 2"	Base	Each	1.00	\$1,179.47	\$1,179.47		
	2. CITY #C1344-30-D	30" MJ CAP TAPPED DI 2"	Base	Each	2.00	\$2,955.47	\$5,910.94		
	3. CITY #P2341-24-D	24" PLUG, MJ TAPPED 2"	Base	Each	1.00	\$2,057.66	\$2,057.66		
	4. CITY #P2341-30-D	30" MJ PLUG TAPPED DI 2"	Base	Each	1.00	\$4,347.13	\$4,347.13		

5. CITY #C3372- 24-D	24" FL X MJ ADAPTOR	Base	Each	1.00	\$1,746.56	\$1,746.56
6. CITY #T1340- 24-D	24"X24"X24" MJ TEE DI	Base	Each	1.00	\$4,595.56	\$4,595.56
7. CITY # T1340-30- D	30" X 30" X 30" TEE, TM	Base	Each	1.00	\$11,779.60	\$11,779.60
8. CITY #T1340- 30X24X30- D	30" X 24" X 30" TEE, MJ - (30" EACH END, 24" ON THE SIDE)	Base	Each	1.00	\$8,266.11	\$8,266.11
9. CITY #S2341- 24X15-D	24"X15" SLEEVE, MJ	Base	Each	1.00	\$1,868.88	\$1,868.88
10. CITY #S2341- 30X24-D	30" X 24" SLEEVE, MJ	Base	Each	1.00	\$5,018.41	\$5,018.41
11. CITY #GL1000- 24	24" EBAA 1100 MEGALUG - 316 SST BOLTS	Base	Each	30.00	\$968.03	\$29,040.90
12. CITY #GL1000- 30	30" EBAA 1100 MEGALUG - 316 SST BOLTS	Base	Each	16.00	\$2,416.14	\$38,658.24
13. CITY #GL1000- 36	36" EBAA 1100 MEGALUG - 316 SST BOLTS	Base	Each	1.00	\$2,943.95	\$2,943.95

14.	24" EBBA MEGALUG BOLT & GASKET KIT - 316 SST BOLTS	Base	Each	1.00	\$443.42	\$443.42
15.	30" EBAA MEGALUG BOLT & GASKET KIT - 316 SST BOLTS	Base	Each	1.00	\$1,360.52	\$1,360.52
16.	36" EBAA MEGALUG BOLT & GASKET KIT - 316 STT BOLTS	Base	Each	1.00	\$1,627.29	\$1,627.29
17. CITY #P1300-24	24" DUCTILE IRON TYTON JOINT PIPE	Base	FT	36.00	\$134.39	\$4,838.04
18. CITY #P1300-30	30" DUCTILE IRON TYTON JOINT PIPE	Base	FT	36.00	\$207.49	\$7,469.64
19.	24" EBAA 1100HD SPLIT MEGALUG RESTRAINT HARNESS 316 SST BOLTS	Base	Each	5.00	\$2,359.45	\$11,797.25

20.	30" EBAA 1100HD SPLIT MEGALUG RESTRAINT HARNESS 316 SST BOLTS	Base	Each	4.00	\$4,427.85	\$17,711.40
<b>Total Base Bid</b>		\$162,660.97				



**Certification of Materials Origin**  
(Required for Acceptance of Construction Materials)

Project Title Plains Booster Station	Contract # RFQ 6230-24
Contractor City of Spokane	
Estimate Number RFQ-6230-24	

The following Certification of Materials Origin is made for the purposes of establishing materials acceptance under Contract Provisions entitled "Build America, Buy America (BABA)" in accordance with Public Law 117-58. Materials as described above are furnished for use in compliance with the certification as noted in 1, 2, or 3 below. **For certification of steel or iron products use DOT form 350-109.**

- 1. The materials covered by this certification are American Made with all manufacturing processes entirely within the United State of America.
- 2. No material was installed for the Estimate Number noted above.
- 3. The materials furnished for this project under this certification contain construction materials manufactured, all or in part, outside the United States of America, as indicated below.

The Description of these materials and the Country of Origin of these materials is as follows (Include Bid Item, quantity and manufacturer):

NONE

The Invoice Cost for the above described foreign-made materials is:

NONE

I declare under penalty of perjury under the laws of the State of Washington that the foregoing is true and correct.

Core & Main \_\_\_\_\_  
Contractor

*Kevin Hoglund*  
\_\_\_\_\_  
Authorized Corporate Official Signature

9-19-24 \_\_\_\_\_  
Date

Spokane, Wa \_\_\_\_\_  
Place

**The following items are defined as Construction Materials and must be manufactured in the United States:**

1. Non-ferrous metals;
2. Plastic and polymer-based products (including polyvinylchloride, composite building materials, and polymers used in fiber optic cables);
3. Glass (including optic glass)
4. Lumber
5. Drywall

**All steel or iron materials must be certified on Form 350-109.**



**Certification of Materials Origin**  
(Required for Acceptance of Steel or Iron Materials)

Project Title	Contract #
Contractor	
Subcontractor	
Manufacturer/Supplier	
Materials: Bid Item No. / Bid Item Description	Quantity
Material Description	

The following Certification of Materials Origin is made for the purposes of establishing materials acceptance under Contract Provisions entitled "Buy America." and "Build America/Buy America." Materials as described above are furnished for use in compliance with the certification as noted in 1 or 2 below. Manufacturing processes for the materials are defined on the back of this form.

1. The materials covered by this certification are American-Made with all manufacturing processes entirely within the United States of America.
2. The materials furnished for this project under this certification contain steel or iron manufactured, all or in part, outside the United States of America, as indicated below.

The Description of these materials and the Country of Origin of these materials is as follows:

The Invoice Cost for the above described foreign-made materials is:

I declare under penalty of perjury under the laws of the State of Washington that the foregoing is true and correct.

Select One:   Contractor   Subcontractor   Manufacturer   Supplier   \_\_\_\_\_  
Company Name

*Kevin Hoglund*

\_\_\_\_\_

Authorized Corporate Official Signature                      Printed Name                      Date



## **The following items are considered to be Steel or Iron Manufacturing Processes**

1. Any process from the original reduction from ore to the finished product constitutes a manufacturing process for iron. Foreign source steel ingots or foreign source steel billets used in any manufacturing process of a steel product is considered foreign steel under the Buy America or Build America/Buy America Provisions.
2. Production of Steel by any of the following processes:
  - a. Open Hearth Furnace.
  - b. Basic Oxygen.
  - c. Electric Furnace.
  - d. Direct Reduction.
3. Rolling, heat treating, and any other similar processing.
4. Fabrication of the products:
  - a. Spinning wire into cable or strand.
  - b. Corrugating and rolling into culverts.
  - c. Shop fabrication.
5. Protective coatings such as zinc, aluminum, epoxy, paint, or any other coating that protects or enhances the value of steel or iron.
6. Due to a nationwide waiver, Buy America does not apply to raw materials (iron ore and alloys), scrap (recycled steel or iron), and pig iron or processed, pelletized, and reduced iron ore.



CITY OF SPOKANE - Water Department

**BID TABULATION**

RFQ 6230-24					
Miscellaneous Waterworks Products - Plains Booster Station					
	Description	QTY	Core & Main	Consolidated Supply Co.	Ferguson Waterworks
1. CITY #C1344-24-D	24" MJ CAP TAPPED DI 2"	1	\$1,179.47	\$1,216.72	\$1,191.50
2. CITY #C1344-30-D	30" MJ CAP TAPPED DI 2"	2	\$5,910.94	\$6,097.60	\$5,971.56
3. CITY #P2341-24-D	24" PLUG, MJ TAPPED 2"	1	\$2,057.66	\$2,122.63	\$2,078.85
4. CITY #P2341-30-D	30" MJ PLUG TAPPED DI 2"	1	\$4,347.13	\$4,484.40	\$4,391.75
5. CITY #C3372-24-D	24" FL X MJ ADAPTOR	1	\$1,746.56	\$3,026.21	\$1,764.50
6. CITY #T1340-24-D	24"X24"X24" MJ TEE DI	1	\$4,595.56	\$4,740.46	\$4,642.75
7. CITY # T1340-30-D	30" X 30" X 30" TEE, TM	1	\$11,779.60	\$12,151.79	\$11,900.00
8. CITY #T1340-30X24X30-D	30" X 24" X 30" TEE, MJ - (30" EACH END, 24" ON THE SIDE)	1	\$8,266.11	\$8,527.14	\$8,351.25
9. CITY #S2341-24X15-D	24"X15" SLEEVE, MJ	1	\$1,868.88	\$1,927.90	\$1,888.00
10. CITY #S2341-30X24-D	30" X 24" SLEEVE, MJ	1	\$5,018.41	\$5,176.88	\$5,070.00
11. CITY #GL1000-24	24" EBAA 1100 MEGALUG - 316 SST BOLTS	30	\$29,040.90	\$29,957.70	\$29,340.00
12. CITY #GL1000-30	30" EBAA 1100 MEGALUG - 316 SST BOLTS	16	\$38,658.24	\$39,877.76	\$39,056.00
13. CITY #GL1000-36	36" EBAA 1100 MEGALUG - 316 SST BOLTS	1	\$2,943.95	\$3,005.93	\$2,943.75
14	24" EBBA MEGALUG BOLT & GASKET KIT - 316 SST BOLTS	1	\$443.42	\$618.15	\$1,444.50
15	30" EBAA MEGALUG BOLT & GASKET KIT - 316 SST BOLTS	1	\$1,360.52	\$1,892.02	\$1,862.50
16	36" EBAA MEGALUG BOLT & GASKET KIT - 316 STT BOLTS	1	\$1,627.29	\$2,257.54	\$2,222.50

17. CITY #P1300-24	24" DUCTILE IRON TYTON JOINT PIPE	36	\$4,838.04	\$5,062.68	\$12,384.00
18. CITY #P1300-30	30" DUCTILE IRON TYTON JOINT PIPE	36	\$7,469.64	\$9,532.44	\$8,640.00
	24" EBAA 1100HD SPLIT MEGALUG RESTRAINT HARNESS				
19	316 SST BOLTS	5	\$11,797.25	\$12,045.60	\$11,797.50
	30" EBAA 1100HD SPLIT MEGALUG RESTRAINT HARNESS				
20	316 SST BOLTS	4	\$17,711.40	\$18,084.24	\$17,711.00
	Sales Tax 9%		\$14,639.49	\$15,462.52	\$15,718.67
	Total		\$177,300.46	\$187,268.31	\$190,370.58

PLEASE NOTE THIS TABULATION IS NOT AN INDICATION OF AWARD RECOMMENDATION.



**Agenda Sheet for City Council:**

**Committee:** PIES **Date:** 10/21/2024

**Committee Agenda type:** Consent

**Date Rec'd** 10/22/2024

**Clerk's File #** OPR 2024-0934

**Cross Ref #**

**Project #**

**Council Meeting Date:** 11/04/2024

<b>Submitting Dept</b>	WATER & HYDROELECTRIC SERVICES	<b>Bid #</b>	PW ITB 6208-24
------------------------	--------------------------------	--------------	----------------

<b>Contact Name/Phone</b>	LOREN SEARL 509-625-7821	<b>Requisition #</b>	RE #20549
---------------------------	--------------------------	----------------------	-----------

<b>Contact E-Mail</b>	LSEARL@SPOKANECITY.ORG		
-----------------------	------------------------	--	--

<b>Agenda Item Type</b>	Contract Item		
-------------------------	---------------	--	--

<b>Council Sponsor(s)</b>	BWILKERSON KKLITZKE JBINGLE		
---------------------------	-----------------------------	--	--

<b>Agenda Item Name</b>	4100 WAT-2022-1638 PH 2 TRASH RAKE		
-------------------------	------------------------------------	--	--

**Agenda Wording**

Approve contract with K&N Electric Motors Inc. (Spokane, WA) to replace the failing trash rake on Powerhouse 2 at the Upriver Hydroelectric Project - \$1,246,438.37.

**Summary (Background)**

The existing trash rake is from 1984 and has reached its life expectancy. The current trash rake has safety and maintenance concerns and affects power generation due to its inability to clean the intake grates timely. The attached proposal will replace the entire trash rake system on powerhouse 2 with a new, proven installation that will improve worker safety and increase total power generation. The electricity that Upriver produces greatly offsets the cost of pumping water in the entire distribution system.

Lease? NO Grant related? NO Public Works? YES

**Fiscal Impact**

Approved in Current Year Budget? YES

Total Cost	\$ 1,246,438.37
------------	-----------------

Current Year Cost	\$
-------------------	----

Subsequent Year(s) Cost	\$ NA
-------------------------	-------

**Narrative**

This project was publicly bid using City of Spokane Purchasing policies and procedures. All possible attempts were made for competitive and responsive bidding

**Amount**

**Budget Account**

Expense	\$ 1,246,438.37	# 4100 42490 94340 56501 11086
Select	\$	#
Select	\$	#
Select	\$	#
	\$	#
	\$	#



## Committee Briefing Paper

### Public Infrastructure, Environment & Sustainability Committee

<b>Committee Date</b>	10/21/2024
<b>Submitting Department</b>	Water and Hydroelectric Services
<b>Contact Name</b>	Loren Searl
<b>Contact Email &amp; Phone</b>	<a href="mailto:lsearl@spokanecity.org">lsearl@spokanecity.org</a> 509-625-7821
<b>Council Sponsor(s)</b>	Wilkerson, Klitzke, Bingle
<b>Select Agenda Item Type</b>	<input checked="" type="checkbox"/> Consent <input type="checkbox"/> Discussion    Time Requested:
<b>Agenda Item Name</b>	WAT-2022-1638 PH 2 Trash Rake
<b>Proposed Council Action</b>	<input checked="" type="checkbox"/> Approval to proceed to Legislative Agenda <input type="checkbox"/> Information Only
<b>Summary (Background)</b>	<p>This project is to replace the failing trash rake on Powerhouse 2 at the Upriver Hydroelectric Project. The existing trash rake is from 1984 and has reached its life expectancy. The current trash rake has safety and maintenance concerns and affects power generation due to its inability to clean the intake grates timely. The attached proposal will replace the entire trash rake system on powerhouse 2 with a new, proven installation that will improve worker safety and increase total power generation. The electricity that Upriver produces greatly offsets the cost of pumping water in the entire distribution system.</p>
<p>*use the Fiscal Impact box below for relevant financial information</p>	<p><b>Fiscal Impact</b></p> <p><b>Approved in current year budget?</b>    <input checked="" type="checkbox"/> Yes    <input type="checkbox"/> No    <input type="checkbox"/> N/A</p> <p>Total Cost: <u>\$1,246,438.37</u></p> <p>    Current year cost: \$1,246,438.37</p> <p>    Subsequent year(s) cost:</p> <p><b>Narrative:</b> <u>This project was publicly bid using City of Spokane Purchasing policies and procedures. All possible attempts were made for competitive and responsive bidding.</u></p> <p><b>Funding Source</b>    <input checked="" type="checkbox"/> One-time    <input type="checkbox"/> Recurring    <input type="checkbox"/> N/A</p> <p>Specify funding source: Program revenue</p> <p>Is this funding source sustainable for future years, months, etc? Water Dept CIP, 4100-42490-94340-56501-11086</p> <p><b>Expense Occurrence</b>    <input checked="" type="checkbox"/> One-time    <input type="checkbox"/> Recurring    <input type="checkbox"/> N/A</p> <p>Other budget impacts: (revenue generating, match requirements, etc.) Increase to hydroelectric power generation.</p>
<b>Operations Impacts</b> (If N/A, please give a brief description as to why)	
<ul style="list-style-type: none"> <li>• What impacts would the proposal have on historically excluded communities?</li> </ul>	

Public works projects and services aim to improve infrastructure that serves all citizens and businesses. We strive to offer a consistent level of service to all, to distribute public investment throughout the community, and to respond to gaps in services identified in various City plans.

- How will data be collected, analyzed, and reported concerning the effect of the program/policy by racial, ethnic, gender identity, national origin, income level, disability, sexual orientation, or other existing disparities?

This work is for the Upriver Hydroelectric project and is not a public-facing program.

- How will data be collected regarding the effectiveness of this program, policy, or product to ensure it is the right solution?

Public Works follows the City's established procurement and public works bidding regulations and policies to bring items forward, and then uses contract management best practices to ensure desired outcomes and regulatory compliance.

- Describe how this proposal aligns with current City Policies, including the Comprehensive Plan, Sustainability Action Plan, Capital Improvement Program, Neighborhood Master Plans, Council Resolutions, and others?

This work is part of the Capital Improvement Program and is necessary to improve failing infrastructure, ensure worker safety, and increase power production.

#### **Council Subcommittee Review**

- Please provide a summary of council subcommittee review. If not reviewed by a council subcommittee, please explain why not.



City of Spokane  
**PUBLIC WORKS AGREEMENT**  
Title: **Replacement of Powerhouse #2  
Trash Rake System**

This Agreement is made and entered into by and between the **CITY OF SPOKANE** as (“City”), a Washington municipal corporation, and **K & N ELECTRIC, AN IMPEL COMPANY**, whose address is 415 North Fancher Road, Spokane Valley, Washington 99212, as (“Contractor”), individually hereafter referenced as a “Party”, and together as the “Parties”.

1. PERFORMANCE. The Contractor will do all work, furnish all labor, materials, tools, construction equipment, transportation, supplies, supervision, organization and other items of work and costs necessary for the proper execution and completion of the work described in the specifications entitled **UPRIVER DAM HYDROELECTRIC PROJECT – ENGINEER, FURNISH AND INSTALL A REPLACEMENT POWERHOUSE #2 TRASH RAKE SYSTEM, PW ITB 6208-24 (see Exhibit B)**.
2. CONTRACT DOCUMENTS. The Contract documents are this Contract, the Contractor’s completed bid proposal form, unit price bid forms, contract provisions, contract plans & specifications & appendices, standard specifications, standard plans, addenda, City of Spokane invitation to bid, various certifications and affidavits, supplemental agreements, change orders and subsurface boring logs (if any). In the event of a conflict between these documents, PW Invitation to Bid shall be used to determine prevailing contract document. These contract documents are on file in the Water Department and are incorporated into this Contract by reference as if they were set forth at length. In the event of a conflict, or to resolve an ambiguity or dispute, federal and state requirements supersede this Contract, and this Contract supersedes the other contract documents.
3. TIME OF PERFORMANCE. The time of performance of the Contract shall begin on November 1, 2024, and shall run through December 21, 2025. Project time of completion and working days in accordance with contract documents.
4. LIQUIDATED DAMAGES. Liquidated damages shall be in accordance with the contract documents.
5. TERMINATION. Either party may terminate this Contract by thirty (30) days written notice to the other party. In the event of such termination, the City shall pay the Contractor for all work previously authorized and performed prior to the termination date.
6. COMPENSATION. Total compensation for Contractor’s services under this Contract shall be a maximum amount not to exceed **ONE MILLION TWO HUNDRED FORTY-SIX THOUSAND FOUR HUNDRED THIRTY-EIGHT AND 37/100 DOLLARS (\$1,246,438.37)**, plus applicable taxes, unless modified by a written amendment to this Contract. This is the maximum amount to be paid under this Contract for the work described in Section 2 above, and shall not be exceeded without the prior written authorization of the City in the form of an executed amendment to this Contract.



7. PAYMENT. The Contractor will send its applications for payment to the Spokane Water & Hydroelectric Department, 914 East North Foothills Drive, Spokane, Washington 99207. All invoices should include the Department Contract No. "OPR 202-XXXX" and an approved L & I Intent to Pay Prevailing Wage number. The final invoice should include an approved Affidavit of Wages Paid number. Payment will not be made without this documentation included on the invoice. **Payment will be made via direct deposit/ACH** within thirty (30) days after receipt of the Company's application except as provided by state law. Five percent (5%) of the Contract price may be retained by the City, in accord with RCW 60.28 for a minimum of forty five (45) days after final acceptance, as a trust fund for the protection and payment of: the claims of any person arising under the Contract; and the State with respect to taxes imposed pursuant to Titles 50, 51 and 82 RCW which may be due from the Contractor.

8. INDEMNIFICATION. The Contractor shall defend, indemnify, and hold the City and its officers and employees harmless from all claims, demands, or suits at law or equity asserted by third parties for bodily injury (including death) and/or property damage which arise from the Contractor's negligence or willful misconduct under this Agreement, including attorneys' fees and litigation costs; provided that nothing herein shall require a Contractor to indemnify the City against and hold harmless the City from claims, demands or suits based solely upon the negligence of the City, its agents, officers, and employees. If a claim or suit is caused by or results from the concurrent negligence of the Contractor's agents or employees and the City, its agents, officers and employees, this indemnity provision shall be valid and enforceable to the extent of the negligence of the Contractor, its agents or employees. The Contractor specifically assumes liability and agrees to defend, indemnify, and hold the City harmless for actions brought by the Contractor's own employees against the City and, solely for the purpose of this indemnification and defense, the Contractor specifically waives any immunity under the Washington State industrial insurance law, or Title 51 RCW. The Contractor recognizes that this waiver was specifically entered into pursuant to the provisions of RCW 4.24.115 and was the subject of mutual negotiation. The indemnity and agreement to defend and hold the City harmless provided for in this section shall survive any termination or expiration of this agreement.

9. BONDS. The Contractor may not commence work until it obtains all insurance, permits and bonds required by the contract documents and applicable law. This includes the execution of a performance bond and a payment bond on the forms attached, each equal to one hundred percent (100%) of the contract price, and written by a corporate surety company licensed to do business in Washington State.

10. INSURANCE. During the period of the Agreement, the Contractor shall maintain in force at its own expense, each insurance noted below with companies or through sources approved by the State Insurance Commissioner pursuant to Title 48 RCW:

A. **Worker's Compensation Insurance** in compliance with RCW 51.12.020, which requires subject employers to provide workers' compensation coverage for all their subject workers and Employer's Liability Insurance in the amount of \$1,000,000;

B. **General Liability Insurance** on an occurrence basis, with a combined single limit of not less than \$1,000,000 each occurrence for bodily injury and property damage. It shall include contractual liability coverage for the indemnity provided under this agreement. It shall provide that the City, its officers and employees are additional insureds but only with respect to the Contractor's services to be provided under this Agreement;

- i. Acceptable supplementary Umbrella coverage in combination with Commercial General Liability policy shall be a minimum of \$2M in order to meet the minimum insurance coverages required under this contract;

C. **Automobile Liability Insurance** with a combined single limit, or the equivalent of not less than \$1,000,000 each accident for bodily injury and property damage, including coverage for owned, hired and non-owned vehicles; and

D. **Property Insurance** if materials and supplies are furnished by the Contractor. The amount of the insurance coverage shall be the value of the materials and supplies of the completed value of improvement. Hazard or XCU (explosion, collapse, underground) insurance should be provided if any hazard exists.

There shall be no cancellation, material change, or intent not to renew the insurance coverage(s) without thirty (30) days written notice from the Contractor or its insurer(s) or insurers authorized representative to the City. As evidence of the insurance coverages required by this Agreement, the Contractor shall furnish ACORD form insurance certificates to the City at the time it returns the signed Agreement. The certificate shall specify all of the parties who are additional insureds to the extent of Company's indemnify obligations, and include applicable blanket-form policy endorsements, including the blanket-form notice of cancellation endorsements (30 days). The Contractor shall be financially responsible for all pertinent deductibles, self-insured retentions, and/or self-insurance.

11. **CONTRACTOR'S WARRANTY.** The Contractor's warranty for all work, labor and materials shall be in accordance with the contract documents.

12. **WAGES.** The Contractor and all subcontractors will submit a "Statement of Intent to Pay Prevailing Wages" certified by the industrial statistician of the Department of Labor and Industries, prior to any payments. The "Statement of Intent to Pay Prevailing Wages" shall include: (1) the Contractor's registration number; and (2) the prevailing wages under RCW 39.12.020 and the number of workers in each classification. Each voucher claim submitted by the Contractor for payment on a project estimate shall state that the prevailing wages have been paid in accordance with the "Statement(s) of Intent to Pay Prevailing Wages" on file with the City. Prior to the payment of funds held under RCW 60.28, the Contractor and subcontractors must submit an "Affidavit of Wages Paid" certified by the industrial statistician.

13. **STATEMENT OF INTENT TO PAY PREVAILING WAGES TO BE POSTED.** The Contractor and each subcontractor required to pay the prevailing rate of wages shall post in a location readily visible at the job site: (1) a copy of a "Statement of Intent to Pay Prevailing Wages" approved by the industrial statistician of the State Department of Labor and Industries; and (2) the address and telephone number of the industrial statistician of the Department of Labor and Industries where a complaint or inquiry concerning prevailing wages may be made.

14. **PUBLIC WORKS REQUIREMENTS.** The Contractor and each subcontractor are required to fulfill the Department of Labor and Industries Public Works and Prevailing Wage Training Requirement under RCW 39.04.350. The contractor must verify responsibility criteria for each first tier subcontractor, and a subcontractor of any tier that hires other subcontractors must verify the responsibility criteria listed in RCW 39.04.350(1) for each of its subcontractors. Verification shall include that each subcontractor, at the time of subcontract execution, meets the responsibility criteria. This verification requirement, as well as responsibility criteria, must be included in every public works contract and subcontract of every tier.

15. SUBCONTRACTOR RESPONSIBILITY.

A. The Contractor shall include the language of this section in each of its first tier subcontracts, and shall require each of its subcontractors to include the same language of this section in each of their subcontracts, adjusting only as necessary the terms used for the contracting parties. Upon request of the City, the Contractor shall promptly provide documentation to the City demonstrating that the subcontractor meets the subcontractor responsibility criteria below. The requirements of this section apply to all subcontractors regardless of tier.

B. At the time of subcontract execution, the Contractor shall verify that each of its first tier subcontractors meets the following bidder responsibility criteria:

1. Have a current certificate of registration in compliance with chapter 18.27 RCW, which must have been in effect at the time of subcontract bid submittal;
2. Have a current Washington Unified Business Identifier (UBI) number;
3. If applicable, have:
  - a. Have Industrial Insurance (workers' compensation) coverage for the subcontractor's employees working in Washington, as required in Title 51 RCW;
  - b. A Washington Employment Security Department number, as required in Title 50 RCW;
  - c. A Washington Department of Revenue state excise tax registration number, as required in Title 82 RCW;
  - d. An electrical contractor license, if required by Chapter 19.28 RCW;
  - e. An elevator contractor license, if required by Chapter 70.87 RCW.
4. Not be disqualified from bidding on any public works contract under RCW 39.06.010 or 39.12.065 (3).

C. On Public Works construction projects, as defined in RCW 39.04.010, with an estimated cost of six hundred thousand dollars (\$600,000) or more, at least fifteen (15) percent of the labor hours on each project shall be performed by apprentices enrolled in a State-approved apprenticeship program; and for each contract in the project fifteen (15) percent of the labor hours for each craft that has an available state-approved apprenticeship program for Spokane County and utilizes more than one hundred sixty (160) hours in each contract shall be performed by apprentices enrolled in a state-approved apprenticeship program.

1. Subcontracting Requirements. The utilization percentages for apprenticeship labor for Public Works construction contracts shall also apply to all subcontracts of one hundred thousand dollars (\$100,000) or more within those contracts, and at least fifteen percent (15%) of the labor hours for each such subcontract shall be performed by apprentices in a state-approved apprenticeship program. For each craft that has an available apprenticeship program for Spokane county and performs more than one hundred sixty (160) hours on each project, fifteen (15) percent of the labor hours shall be performed by apprentices enrolled in a State-approved apprenticeship program.
2. Each subcontractor which this chapter applies is required to execute a form, provided by the city, acknowledging that the requirements of Article X 07.06 SMC are

applicable to the labor hours for the project.

16. NONDISCRIMINATION. No individual shall be excluded from participation in, denied the benefit of, subjected to discrimination under, or denied employment in the administration of or in connection with this Contract because of age, sex, race, color, religion, creed, marital status, familial status, sexual orientation including gender expression or gender identity, national origin, honorably discharged veteran or military status, the presence of any sensory, mental or physical disability, or use of a service animal by a person with disabilities. The Contractor agrees to comply with, and to require that all subcontractors comply with, Section 504 of the Rehabilitation Act of 1973 and the Americans with Disabilities Act, as applicable to the Contractor.

17. EXECUTIVE ORDER 11246.

- A. The Contractor will not discriminate against any employee or applicant for employment because of race, color, religion, sex or national origin. The Contractor will take affirmative action to insure that applicants are employed, and that employees are treated during employment, without regard to their race, color, religion, sex or national origin. Such action shall include but not be limited to the following: employment upgrading, demotion or transfer; recruitment or recruitment advertising; layoff or termination; rates of pay or other forms of compensation; and selection for training, including apprenticeship. The Contractor agrees to post in conspicuous places, available to employees and applicants for employment, notices to be provided by the contracting officer setting forth the provisions of this nondiscrimination clause.
- B. The Contractor will, in all solicitations or advertisements for employees placed by or on behalf of the Contractor, state that all qualified applicants will receive consideration for employment without regard to race, color, religion, sex or national origin.
- C. The Contractor will send each labor union, or representative of workers with which it has a collective bargaining contract or other contract or understanding, a notice, to be provided by the agency contracting officer, advising the labor union or workers' representative of the Contractor's commitments under Section 202 of Executive Order No. 11246 of September 24, 1965, and shall post copies of the notice in conspicuous places available to employees and applicants for employment.
- D. The Contractor will comply with all provisions of Executive Order No. 11246 of September 24, 1965, and of the rules, regulations, and relevant orders of the Secretary of Labor.
- E. The Contractor will furnish all information and reports required by Executive Order No. 11246 of September 24, 1965, and by the rules, regulations and orders of the Secretary of Labor, or pursuant thereto, and will permit access to its books, records, and accounts by the contracting agency and the Secretary of Labor for purposes of investigation to ascertain compliance with such rules, regulations and orders.
- F. In the event of the Contractor's noncompliance with the nondiscrimination clauses of this Contract or with any of such rules, regulations or orders, this Contract may be canceled, terminated or suspended in whole or in part, and the Contractor may be declared ineligible for further government contracts in accordance with procedures authorized in Executive Order No. 11246 of September 24, 1965, and such other sanctions may be imposed and remedies invoked as provided in Executive Order No. 11246 of September 24, 1965, or by rule, regulation, or order of the Secretary of Labor, or as otherwise provided by law.
- G. The Contractor will include the provisions of paragraphs A through G in every subcontract or purchase order unless exempted by rules, regulations or orders of the Secretary of Labor issued pursuant to Section 204 of Executive Order No. 11246 of September 24, 1965, so that such provisions will be binding upon each subcontractor or vendor. The Contractor will take such action with respect to any subcontract or purchase order as may be directed by the

Secretary of Labor as a means of enforcing such provisions including sanctions for noncompliance: PROVIDED, HOWEVER, that in the event the Contractor becomes involved in, or is threatened with, litigation with a subcontractor or vendor as the result of such direction, the Contractor may request the United States to enter into such litigation to protect the interests of the United States.

18. DEBARMENT AND SUSPENSION. The Contractor has provided its certification that it is in compliance with and shall not contract with individuals or organizations which are debarred, suspended, or otherwise excluded from or ineligible from participation in Federal Assistance Programs under Executive Order 12549 and "Debarment and Suspension", codified at 29 CFR part 98.

19. ASSIGNMENTS. The Contractor may not assign, transfer or sublet any part of the work under this Contract, or assign any monies due, without the written approval of the City, except as may be required by law. In the event of assignment of accounts or monies due under this Contract, the Contractor specifically agrees to give immediate written notice to the City Administrator, no later than five (5) business days after the assignment.

20. ANTI-KICKBACK. No officer or employee of the City of Spokane, having the power or duty to perform an official act or action related to this Contract shall have or acquire any interest in the Contract, or have solicited, accepted or granted a present or future gift, favor, service or other thing of value from or to any person involved in the Contract.

21. COMPLIANCE WITH LAWS. Each party shall comply with all applicable federal, state, and local laws and regulations that are incorporated herein by reference.

22. DISPUTES. This Contract shall be performed under the laws of the State of Washington. Any litigation to enforce this Contract or any of its provisions shall be brought in Spokane County, Washington.

23. SEVERABILITY. In the event any provision of this Contract should become invalid, the rest of the Contract shall remain in full force and effect.

24. AUDIT / RECORDS. The Contractor and its subcontractors shall maintain for a minimum of three (3) years following final payment all records related to its performance of the Contract. The Contractor and its subcontractors shall provide access to authorized City representatives, at reasonable times and in a reasonable manner to inspect and copy any such record. In the event of conflict between this provision and related auditing provisions required under federal law applicable to the Contract, the federal law shall prevail.

25. BUSINESS REGISTRATION REQUIREMENT. Section 8.01.070 of the Spokane Municipal Code states that no person may engage in business with the City without first having obtained a valid annual business registration. The Contractor shall be responsible for contacting the State of Washington Business License Services at [www.dor.wa.gov](http://www.dor.wa.gov) or 360-705-6741 to obtain a business registration. If the Contractor does not believe it is required to obtain a business registration, it may contact the City's Taxes and Licenses Division at (509) 625-6070 to request an exemption status determination.

26. CONSTRUAL. The Contractor acknowledges receipt of a copy of the contract documents and agrees to comply with them. The silence or omission in the contract documents concerning any detail required for the proper execution and completion of the work means that only the best general

practice is to prevail and that only material and workmanship of the best quality are to be used. This Contract shall be construed neither in favor of nor against either party.

27. MODIFICATIONS. The City may modify this Contract and order changes in the work whenever necessary or advisable. The Contractor will accept modifications when ordered in writing by the Director of Engineering Services, and the Contract time and compensation will be adjusted accordingly.

28. INTEGRATION. This Contract, including any and all exhibits and schedules referred to herein or therein set forth the entire Agreement and understanding between the parties pertaining to the subject matter and merges all prior agreements, negotiations and discussions between them on the same subject matter.

29. FORCE MAJEURE. Neither party shall be liable to the other for any failure or delay in performing its obligations hereunder, or for any loss or damage resulting therefrom, due to: (1) acts of God or public enemy, acts of government, riots, terrorism, fires, floods, strikes, lock outs, epidemics, act or failure to act by the other party, or unusually severe weather affecting City, Contractor or its subcontractors, or (2) causes beyond their reasonable control and which are not foreseeable (each a "Force Majeure Event"). In the event of any such Force Majeure Event, the date of delivery or performance shall be extended for a period equal to the time lost by reason of the delay.

**K & N ELECTRIC, AN IMPEL COMPANY**

**CITY OF SPOKANE**

By \_\_\_\_\_  
Signature Date

By \_\_\_\_\_  
Signature Date

\_\_\_\_\_  
Type or Print Name

\_\_\_\_\_  
Type or Print Name

\_\_\_\_\_  
Title

\_\_\_\_\_  
Title

Attest:

Approved as to form:

\_\_\_\_\_  
City Clerk

\_\_\_\_\_  
Assistant City Attorney

**Attachments that are part of this Contract:**

- Payment Bond
- Performance Bond
- Exhibit A - Certification Regarding Debarment
- Exhibit B – Contractor’s Bid Response to PW ITB 6208-24

**PAYMENT BOND**

We, **K & N ELECTRIC, AN IMPEL COMPANY**, as principal, and \_\_\_\_\_, as surety, are held and firmly bound to the City of Spokane, Washington, in the sum of **ONE MILLION TWO HUNDRED FORTY-SIX THOUSAND FOUR HUNDRED THIRTY-EIGHT AND 37/100 DOLLARS (\$1,246,438.37)**, plus applicable taxes plus applicable taxes, the payment of which, we bind ourselves and our legal representatives and successors, jointly and severally by this document.

The principal has entered into a contract with the City of Spokane, Washington, to do all work and furnish all materials for the **UPRIVER DAM HYDROELECTRIC PROJECT – ENGINEER, FURNISH AND INSTALL A REPLACEMENT POWERHOUSE #2 TRASH RAKE SYSTEM, PW ITB 6208-24**. If the principal shall:

- A. pay all laborers, mechanics, subcontractors, material suppliers and all person(s) who shall supply such person or subcontractors; and pay all taxes and contributions, increases and penalties as authorized by law; and
- B. comply with all applicable federal, state and local laws and regulations;

then this obligation shall be null and void; otherwise it shall remain in full force and effect.

The Surety for value received agrees that no change, extension of time, alteration or addition to the terms of the Contract, the specifications accompanying the Contract, or to the work to be performed under the Contract shall in any way affect its obligation on this bond, except as provided herein, and waives notice of any change, extension of time, alteration or addition to the terms of the Contract or the work performed. The Surety agrees that modifications and changes to the terms and conditions of the Contract that increase the total amount to be paid the Principal shall automatically increase the obligation of the Surety on this bond and notice to Surety is not required for such increased obligation... Any judgment obtained against the City, which relates to or is covered by the contract or this bond, shall be conclusive against the principal and the surety, as to the amount of damages, and their liability, if reasonable notice of the suit has been given.

SIGNED AND SEALED on \_\_\_\_\_.

**K & N ELECTRIC, AN IMPEL COMPANY**  
AS PRINCIPAL

By: \_\_\_\_\_  
Title: \_\_\_\_\_

\_\_\_\_\_  
AS SURETY

A valid POWER OF ATTORNEY  
for the Surety's agent must  
accompany this bond.

By: \_\_\_\_\_  
Its Attorney in Fact

STATE OF WASHINGTON        )  
  ) ss.  
County of \_\_\_\_\_)

I certify that I know or have satisfactory evidence that \_\_\_\_\_  
\_\_\_\_\_ signed this document; on oath stated that he/she was  
authorized to sign the document and acknowledged it as the agent or representative of the  
named surety company which is authorized to do business in the State of Washington, for the  
uses and purposes therein mentioned.

DATED: \_\_\_\_\_

\_\_\_\_\_  
Signature of Notary Public

My appointment expires \_\_\_\_\_

Approved as to form:

\_\_\_\_\_  
Assistant City Attorney



**PERFORMANCE BOND**

We, **K & N ELECTRIC, AN IMPEL COMPANY**, as principal, and \_\_\_\_\_, as Surety, are held and firmly bound to the City of Spokane, Washington, in the sum of **ONE MILLION TWO HUNDRED FORTY-SIX THOUSAND FOUR HUNDRED THIRTY-EIGHT AND 37/100 DOLLARS (\$1,246,438.37)**, plus applicable taxes, for the payment of which, we bind ourselves and our legal representatives and successors, jointly and severally by this document.

The principal has entered into a Contract with the City of Spokane, Washington, to do all the work and furnish all materials for the **UPRIVER DAM HYDROELECTRIC PROJECT – ENGINEER, FURNISH AND INSTALL A REPLACEMENT POWERHOUSE #2 TRASH RAKE SYSTEM, PW ITB 6208-24**. If the principal shall:

- A. promptly and faithfully perform the Contract, and any contractual guaranty and indemnify and hold harmless the City from all loss, damage or claim which may result from any act or omission of the principal, its agents, employees, or subcontractors; and
- B. comply with all applicable federal, state and local laws and regulations;

then this obligation shall be null and void; otherwise it shall remain in full force and effect.

The Surety for value received agrees that no change, extension of time, alteration or addition to the terms of the Contract, the specifications accompanying the Contract, or to the work to be performed under the Contract shall in any way affect its obligation on this bond, except as provided herein, and waives notice of any change, extension of time, alteration or addition to the terms of the Contract or the work performed. The Surety agrees that modifications and changes to the terms and conditions of the Contract that increase the total amount to be paid the Principal shall automatically increase the obligation of the Surety on this bond and notice to Surety is not required for such increased obligation. Any judgment obtained against the City, which relates to or is covered by the Contract or this bond, shall be conclusive against the principal and the Surety, not only as to the amount of damages, but also as to their liability, if reasonable notice of the suit has been given.

SIGNED AND SEALED on \_\_\_\_\_

**K & N ELECTRIC, AN IMPEL COMPANY,  
AS PRINCIPAL**

By: \_\_\_\_\_  
Title: \_\_\_\_\_

\_\_\_\_\_,  
AS SURETY

A valid POWER OF ATTORNEY  
for the Surety's agent must  
accompany this bond.

By: \_\_\_\_\_  
Its Attorney in Fact

STATE OF WASHINGTON            )  
  ) ss.  
County of \_\_\_\_\_ )

I certify that I know or have satisfactory evidence that \_\_\_\_\_  
\_\_\_\_\_ signed this document; on oath stated that  
he/she was authorized to sign the document and acknowledged it as the agent or representative of the  
named Surety Company which is authorized to do business in the State of Washington, for the uses  
and purposes mentioned in this document.

DATED on \_\_\_\_\_.

\_\_\_\_\_  
Signature of Notary

My appointment expires \_\_\_\_\_

Approved as to form:

\_\_\_\_\_  
Assistant City Attorney

**CERTIFICATION REGARDING DEBARMENT, SUSPENSION,  
INELIGIBILITY AND VOLUNTARY EXCLUSION**

1. The undersigned (i.e., signatory for the Subrecipient / Contractor / Consultant) certifies, to the best of its knowledge and belief, that it and its principals:
  - a. Are not presently debarred, suspended, proposed for debarment, declared ineligible, or voluntarily excluded from covered transactions by any federal department or agency;
  - b. Have not within a three-year period preceding this contract been convicted or had a civil judgment rendered against them for commission of fraud or a criminal offense in connection with obtaining, attempting to obtain, or performing a public (federal, state, or local) transaction or contract under a public transaction; violation of federal or state antitrust statutes or commission of embezzlement, theft, forgery, bribery, falsification or destruction of records, making false statements, tax evasion, receiving stolen property, making false claims, or obstruction of justice;
  - c. Are not presently indicted or otherwise criminally or civilly charged by a government entity (federal, state, or local) with commission of any of the offenses enumerated in paragraph (1)(b) of this certification; and,
  - d. Have not within a three-year period preceding this contract had one or more public transactions (federal, state, or local) terminated for cause or default.
2. The undersigned agrees by signing this contract that it shall not knowingly enter into any lower tier covered transaction with a person who is debarred, suspended, declared ineligible, or voluntarily excluded from participation in this covered transaction.
3. The undersigned further agrees by signing this contract that it will include the following clause, without modification, in all lower tier covered transactions and in all solicitations for lower tier covered transactions:

Certification Regarding Debarment, Suspension, Ineligibility and Voluntary Exclusion – Lower Tier Covered Transactions

1. The lower tier contractor certified, by signing this contract that neither it nor its principals is presently debarred, suspended, proposed for debarment, declared ineligible, or voluntarily excluded from participation in this transaction by any federal department or agency.
  2. Where the lower tier contractor is unable to certify to any of the statements in this contract, such contractor shall attach an explanation to this contract.
4. I understand that a false statement of this certification may be grounds for termination of the contract.

<hr style="border: none; border-top: 1px solid black; margin-bottom: 5px;"/> Name of Subrecipient / Contractor / Consultant (Type or Print)	<hr style="border: none; border-top: 1px solid black; margin-bottom: 5px;"/> Program Title (Type or Print)
<hr style="border: none; border-top: 1px solid black; margin-bottom: 5px;"/> Name of Certifying Official (Type or Print)	<hr style="border: none; border-top: 1px solid black; margin-bottom: 5px;"/> Signature
<hr style="border: none; border-top: 1px solid black; margin-bottom: 5px;"/> Title of Certifying Official (Type or Print)	<hr style="border: none; border-top: 1px solid black; margin-bottom: 5px;"/> Date (Type or Print)

EXHIBIT B

## Bid Response Summary

**Bid Number** PW ITB 6208-24  
**Bid Title** Upriver Dam Hydroelectric Project - Engineer, Furnish and Install a replacement Powerhouse #2 Trash Rake System  
**Due Date** Monday, September 30, 2024 1:00:00 PM [(UTC-08:00) Pacific Time (US & Canada)]  
**Bid Status** Closed to Bidding  
**Company** K&N Electric Motors, Inc.  
**Submitted By** Luke Olson - Monday, September 30, 2024 12:44:39 PM [(UTC-08:00) Pacific Time (US & Canada)]  
 lolson@knelectric.com 5098388000

**Comments**

**Question Responses**

Group	Reference Number	Question	Response
MANDATORY PRE-BID MEETING			
	MANDATORY PRE-BID MEETING	A MANDATORY pre-bid meeting and walk through will be held on September 12th, 2024, 10AM at 2701 N Waterworks St, Spokane WA 99212). Only those vendors who attend the Mandatory Pre-Bid Conference will be able to bid on this project. Interested Vendor(s) shall provide for preliminary research and engineering needs during the Walkthrough. Questions necessary for bidding should be asked during the walkthrough and/or shall be required to be submitted through the procurement website. Known drawings/prints of the Powerhouse 2 structure will be available during walkthrough for reference. Digital copies of known drawings/prints of Powerhouse 2 structure will be provided to interested Vendors(s) upon written request after the walkthrough.	I agree
BACKGROUND AND PURPOSE			
	1	The City of Spokane Water Department is seeking responses from interested bidders to engineer, manufacture, and install a replacement trash rake system for Powerhouse 2 at the City of Spokane's Upriver Hydroelectric Project. The new trash rake will replace a 1984 vintage trash rake that travels on rails. The new design shall follow the specifications of this bid and the Specifications in the documents tab.	I agree
GENERAL INFORMATION			
	CONTRACTOR'S REPRESENTATION	The Contractor by making its Bid represents that it has read and understands the specifications; and has visited the site and familiarized itself with the local conditions under which the Work is to be performed.	Acknowledged
	QUALIFICATION	Prior to the award of contract, the Contractor shall be required to submit evidence of sufficient facilities, equipment and experience and financial ability to insure completion of the Work, unless waived by the City.	Acknowledged
	AWARD OF CONTRACT	Award of contract, when made by the City, will be to the low responsive-responsible bidder based on cost. Unsuccessful Contractors will not automatically be notified of results.	Acknowledged
	CONTRACT RENEWALS	Contract renewals or extensions may be initiated by the City of Spokane, subject to mutual agreement.	Acknowledged
	EXECUTION OF CONTRACT	Within ten (10) days of contract award the Contractor shall sign and return to the City an executed copy of the contract unless otherwise mutually agreed by the City and Contractor.	Acknowledged

GUARANTEE	The Contractor guarantees all work, labor and materials for one (1) year following final acceptance. If any unsatisfactory condition or defect develops within that time, the Contractor shall immediately place the work in a satisfactory condition, and further repair all damage caused by the condition or defect at its sole expense. The guarantee shall not apply to work which has been abused or neglected by the City.	Acknowledged
PAYMENT	Payment will be made via direct deposit/ACH after receipt of Contractor's application except as provided by state law. If the City objects to all or any portion of the invoice, it shall notify Contractor and reserve the right to only pay that portion of the invoice not in dispute. In that event, the parties shall immediately make every effort to settle the disputed amount.	Acknowledged
REJECTION OF BID	The City reserves the right to reject any or all Bids, to waive minor deviations from the specifications, to waive minor informalities in Bid process whenever it is in the City's best interest, and to accept or reject all or part of this Request for Bids, at the prices shown.	Acknowledged
CONTRACTOR REGISTRATION	The Contractor shall be a Washington State registered "and" licensed Contractor at time of Bid submittal.	Acknowledged
COMPLETION TIME	The bidder agrees to start the work under this contract within ten (10) days of the Notice to Proceed and to substantially complete the specified work six (6) months.	Acknowledged
LIQUIDATED DAMAGES	If the Work is not completed within the stated completion time, the Contractor agrees to pay to the City liquidated damages in the amount zero (0) for each and every calendar day the work remains uncompleted. Which is a reasonable forecast of the damages likely to occur if works is unfinished by the completion date.	Acknowledged
MISCELLANEOUS DOCUMENTATION UPLOAD	Upload any additional documentation here. You can only upload one document so if you have more than one page- combine them into one page before uploading	
<b>PUBLIC WORKS REQUIREMENTS</b>		
1.	The work under this contract constitutes as a public work under state law.	I acknowledge and agree
2.	Payment/performance bonds will be required.	I acknowledge and agree
PERFORMANCE BONDS	The Contractor shall furnish, at its sole expense, a performance and payment bond equal to one hundred percent (100%) of the contract price. The bond shall insure faithful and complete performance of the contract and payment of all obligations to laborers and material men arising from the Project. The bond shall be executed by a Surety company authorized to do business in Washington State, and shall remain in effect for one (1) year following final acceptance of the work. Unless approved by the City, the Surety's name shall appear on the United States Treasury Department's list of authorized Sureties - Circular 570. On contracts of \$150,000.00 or less, in lieu of a surety bond, at the request of the Contractor, the City may retain ten percent (10%) of the contract price for a minimum of forty five (45) days following final acceptance, or until receipt of all releases and settlement of liens, whichever is later, in accord with RCW 39.08010.	I acknowledge and agree
3.	Statutory retainage will be required	I acknowledge and agree
RETAINAGE	Pursuant to chapter 60.28 RCW, the City will retain five percent (5%) (or ten percent (10%) at Contractor's request) from the monies earned by the Contractor. This Retainage shall be held as a trust fund for the protection and payment: (1) to the State of taxes and fees owed by the Contractor; and (2) of any person, mechanic, subcontractor or material man who performs labor or furnishes any supplies toward the Work. Release of Retainage will be made at a minimum of forty five (45) days following final acceptance of Work; provided the following conditions are met:	I acknowledge and agree

RETAINAGE	<p>a. The City has received from the Contractor and each subcontractor a copy of the "Statement of Intent to Pay Prevailing Wages" and an "Affidavit of Wages Paid", approved by the State Department of Labor and Industries (L&amp;I). b. On Contracts greater than \$35,000, the City has received releases from the State Departments of Revenue (DOR), Labor &amp; Industries and Employment Security. c. No claims, as provided by law, have been filed against the retainage In the event a claim is filed, the Contractor shall be paid a portion of the Retainage, which is less than the amount sufficient to pay the claim and potential legal costs.</p>	I acknowledge and agree
4.	<p>The State prevailing rate of wages to be paid to all workmen, laborers or mechanics employed in the performance of any part of this Contract shall be in accordance with the provisions of Chapter 39.12 of the Revised Code of Washington (RCW) and the rules and regulations of the Washington State Department of Labor and Industries (L &amp; I).</p>	I acknowledge and agree
5.	<p>The State of Washington prevailing wage rates applicable for this public works project, which is located in Spokane County, may be found at the following website address of the Department of Labor and Industries:  <a href="https://fortress.wa.gov/lni/wagelookup/prvWagelookup.aspx">https://fortress.wa.gov/lni/wagelookup/prvWagelookup.aspx</a>.  Based on the bid submittal deadline for this project, the applicable effective date for prevailing wages for this project is Septemeber 23, 2024.</p>	I acknowledge and agree
6.	<p>On Public Works construction projects, as defined in RCW 39.04.010, with an estimated cost of six hundred thousand dollars (\$600,000) or more, at least fifteen (15) percent of the labor hours on each project shall be performed by apprentices enrolled in a State-approved apprenticeship program; and for each contract in the project fifteen (15) percent of the labor hours for each craft that has an available state-approved apprenticeship program for Spokane County and utilizes more than one hundred sixty (160) hours in each contract shall be performed by apprentices enrolled in a state-approved apprenticeship program.</p>	I acknowledge and agree
7.	<p>1. Subcontracting Requirements. The utilization percentages for apprenticeship labor for Public Works construction contracts shall also apply to all subcontracts of one hundred thousand dollars (\$100,000) or more within those contracts, and at least fifteen percent (15%) of the labor hours for each such subcontract shall be performed by apprentices in a state-approved apprenticeship program. For each craft that has an available apprenticeship program for Spokane county and performs more than one hundred sixty (160) hours on each project, fifteen (15) percent of the labor hours shall be performed by apprentices enrolled in a State-approved apprenticeship program.2. Each subcontractor which this chapter applies is required to execute a form, provided by the city, acknowledging that the requirements of Article X 07.06 SMC are applicable to the labor hours for the project.</p>	I acknowledge and agree

8.	The Contractor and any subcontractors will submit a <input type="checkbox"/> Statement of Intent to Pay Prevailing Wages <input type="checkbox"/> certified by the industrial statistician of the Department of Labor and Industries, prior to any work or payments. The <input type="checkbox"/> Statement of Intent to Pay Prevailing Wages <input type="checkbox"/> shall include: (1) the Contractor's registration number; and (2) the prevailing wages under RCW 39.12.020 and the number of workers in each classification. Prior to payment of funds held under RCW 39.12.040, the Contractor and subcontractors must submit an <input type="checkbox"/> Affidavit of Wages Paid <input type="checkbox"/> certified by the industrial statistician annually for all work completed within the previous twelve-month period of the unit priced contract (RCW 35.22.620).	I acknowledge and agree
9.	The Contractor is responsible for payment of fees for the approval of "Statements of Intent to Pay Prevailing Wages" and "Affidavits of Wages Paid" and shall make all applications directly to L&I.	I acknowledge and agree
10.	As of July 1, 2019 contractors must have fulfilled the Department of Labor and Industries' Public Works and Prevailing Wage Training Requirement before bidding and/or performing work on public works projects under RCW 39.04.350 and RCW 39.06.020	I acknowledge and agree
<b>TECHNICAL REQUIREMENTS</b>		
PERFORMANCE	The Contractor will do all work, furnish all labor, materials, tools, construction equipment, transportation, supplies, supervision, permits, organization and other items of work and cost necessary for the proper execution and completion of the described Work.	Acknowledged
SCOPE OF WORK	The Contractor has reviewed and understands the document entitled "Powerhouse 2 Trash Rake Replacement" as well as the Specs and Drawings in the 'Documents' tab.	I acknowledge and agree
VENDOR AND/OR CONTRACTOR	All equipment must be sold and serviced by a single Vendor. Multiple Vendors supplying different equipment on a single submittal will be rejected.	I acknowledge and agree
SHIPPING AND DELIVERY	Site has multiple laydown areas available depending on delivery truck size. Contractor shall be responsible for arranging delivery time, unloading of trucks, and ensuring components are undamaged in shipment and unloading. Contractor is responsible for arranging loads and truck size in accordance with the Site limitations.	I acknowledge and agree
SHIPPING AND DELIVERY	Delivery date(s) shall be coordinated with City of Spokane staff at least 2 business days prior.	I acknowledge and agree
SHIPPING AND DELIVERY	All equipment shall be securely boxed, crated, or on pallets to protect from damage and inclement weather during transportation and storage. Precautions shall be taken to protect sensitive equipment from corrosion, rust, or moisture intrusion.	I acknowledge and agree
SHIPPING AND DELIVERY	Each item of equipment shipped shall have legible identification that corresponds to packing lists or manifests.	I acknowledge and agree
SHIPPING AND DELIVERY	Each item of equipment shipped shall have legible identification as to size, weight, particular handling instructions, inclement weather or humidity protection, and or other handling instructions.	I acknowledge and agree
SITE PREP	The Contractor is responsible for the removal of existing trash rake from site. Weight of existing trash rake is unknown. Final offsite destination of existing trash rake is the responsibility of the Contractor.	I acknowledge and agree
SITE PREP	The Contractor shall provide for installation of concrete pad for dumpster. Engineering design, load calculations, and site work shall be the responsibility of Vendor and/or Contractor. Concrete pad shall be engineered to integrate with design of new trash rake system and have adequate support for a loaded dumpster	I acknowledge and agree



SITE PREP	Guard rail at north end of dumpster area shall be moved to the east to accommodate delivery/pickup of dumpsters. native soil under existing guard rail area shall be removed and replaced with 5/8-CSTC suitable for truck traffic	I acknowledge and agree
INSTALLATION	Installation shall be scheduled for between July 15 and September 15, 2025, to accommodate for low river flows and reduced generation	I acknowledge and agree
INSTALLATION	The Contractor agrees to the terms of Installation 4.3 in the Specifications document in the documents tab	I acknowledge and agree
Field Quality Control	The construction, assembly, installation, and start-up of the trash rake system shall be supervised by a factory authorized representative(s) of the Manufacturer.	I acknowledge and agree
Field Quality Control	ON SITE ACCEPTANCE TESTING: The trash rake system shall be tested for compliance with Manufacturer's Submittal and these specifications following delivery, site prep, and installation.	I acknowledge and agree
Field Quality Control	ON SITE ACCEPTANCE TESTING: Testing shall be conducted by a factory authorized representative of the Manufacturer	I acknowledge and agree
Field Quality Control	Results of acceptance testing shall be formally submitted to the City of Spokane in standard report format.	I acknowledge and agree
Start-up and Commissioning	Start-up and commissioning shall be determined by the Manufacturer dependent on the proposed trash rake system and installation particulars. Commissioning period shall not be scheduled for less than one (1) full day (8hrs).	I acknowledge and agree
Start-up and Commissioning (a)	The Manufacturer shall provide an authorized technician experienced in start-up and commissioning of the trash rake system.	I acknowledge and agree
Start-up and Commissioning (b)	Start-up and commissioning shall be considered part of the submittal, and the Vendor shall provide for all travel, accommodations, and compensation.	I acknowledge and agree
Start-up and Commissioning	Any manufacture defects and/or deficient installation concerns of the City Inspector will be addressed during the installation and remedied before start-up.	I acknowledge and agree
Start-up and Commissioning	Results of start-up and commissioning shall be formally submitted to the City of Spokane in standard report format.	I acknowledge and agree
Start-up and Commissioning	Installation site shall be cleared of all construction materials and incidentals.	I acknowledge and agree
Demonstration and Training	The Vendor and/or Manufacturer shall provide for a demonstration of at least one day (8hrs). This period can be scheduled during the 8hr day for start-up and commissioning, if separate persons are provided for each task.	I acknowledge and agree
Demonstration and Training	Operational guides or cheat sheets shall be provided to COS Operators that detail functionality, normal operation, how to reset alarms, and normal operational inspection items.	I acknowledge and agree
Demonstration and Training	During the training period, COS Maintenance staff shall receive training for all maintenance aspects, component replacement, typical wear items, electrical and control system, programming, and troubleshooting. IN addition, all O&M manuals, programming specifics, prints, /drawings, wiring/hydraulic schematics, and or all other relevant documentation shall be supplied to COS staff.	I acknowledge and agree
Demonstration and Training	Results of the demonstration and training shall be formally submitted to the City of Spokane in standard report format.	I acknowledge and agree
SUBMITTALS	Submittals shall be a complete package that includes cut-sheets, shop drawings, capacities and specifications, shipping, costs, and taxes as applicable to the product(s) submitted (see Section 3 in Specifications document).	I acknowledge and agree
SUBMITTALS	Upload any required cut-sheets, shop drawings, capacities and specifications.	Product data and drawings for proposal.pdf

SUBMITTALS	The Submittals shall also include a bid itemization for design, materials, equipment, and installation costs. The City of Spokane (COS) reserves the right to reject submittals that are incomplete or unfinished.	I acknowledge and agree
SUBMITTALS	Submittals must include a Letter of Submittal signed by the appropriate contact person with the Vendor. Submittals are considered legally binding and shall be treated as the Vendors intent to proceed as submitted.	I acknowledge and agree
SUBMITTALS	Letter of Submittal -	Letter of submittal for PW ITB 6208-24.pdf
VENDOR AND/OR CONTRACTOR	The Vendor shall be capable of responding to outages by phone within 1 hour, and capable of being onsite for warranty work with in 24 hours	I acknowledge and agree
VENDOR AND/OR CONTRACTOR	The Vendor must be the authorized representative for the submitted equipment Manufacturer(s) for the Spokane, WA area. Documentation for Manufacturer delineating this authorization must be included in the submittal.	I acknowledge and agree
VENDOR AND/OR CONTRACTOR	The Trash rake system shall be supplied and installed by a Vendor authorized to install, service and repair the proposed equipment. Notice to sublet shall be required for any sub-contractors	I acknowledge and agree
GENERAL REQUIREMENTS		
INTENT OF SPECIFICATIONS	The apparent silence or omission in the specifications as to any detail of the Work to be done or materials to be furnished means that the region's best general practice shall prevail, and that material and workmanship of the best quality shall be used. The specifications shall be interpreted on this basis.	Acknowledged
WASHINGTON STATE RETAIL SALES TAX	A. GENERAL CONSTRUCTION. Retail sales tax, when applicable, will be paid as a separate item, and shall not be included in the Bid price. Sales tax shall be added on the amount due the Contractor and the Contractor shall be responsible for making payment to the State. The City reserves the right to claim an exemption authorized by law.	Acknowledged
WASHINGTON STAT RETAIL SALES TAX	B. PUBLIC STREET IMPROVEMENTS. If the technical requirements in the specifications indicate that all or a portion of the Work is a "public street improvement" as defined by state law, the Contractor shall include all contractor-paid taxes, including use taxes on materials in its Bid price. The City will NOT pay retail sales tax as a separate item.	Acknowledged
PERMITS	Contractor shall be responsible for all permits, signage, equipment, materials and labor, demolition, dust control, reinstallation of all fixtures as needed, and clean up to complete this work in accordance with industry standards governing this type of work.	Acknowledge
GUARANTY	The Contractor guarantees all work, labor and materials for one (1) year following final acceptance of the Work. If any unsatisfactory condition or defect develops within that time, the Contractor shall immediately place the Work in a satisfactory condition, and further repair all damage caused by the condition or defect at its sole expense. This guarantee shall not apply all Work, which has been abused or neglected by the City.	Acknowledged
SUBCONTRACTORS	The Contractor shall not award any portion of the Work to any subcontractor without the City's prior approval. The Contractor shall be fully responsible to the City for the acts, errors and omissions of its subcontractors. No contractual relationship shall be created between any subcontractor and the City.	Acknowledged
INSURANCE	a. Worker's Compensation Insurance in compliance with RCW 51.12.020 which requires subject employers to provide worker's compensation coverage for all their subject workers and Employer's Liability Insurance in the amount of \$1,000,000.00.	Acknowledged

INSURANCE	b. General Liability Insurance on an occurrence basis, with a combined single limit of not less than \$1,000,000.00 for bodily injury and property damage. It shall include premises and operations, independent contractors, products and completed operations, personal injury liability, and contractual liability coverage for the indemnity provided under the contract. It shall provide that the City, its officers and employees are additional insureds but only with respect to the Contractor's services to be provided under the contract; i. Acceptable supplementary Umbrella insurance coverage, combined with the Contractor's General Liability Insurance policy must be a minimum of \$1,500,000.00 in order to meet the insurance coverages required under this Contract;	Acknowledged
INSURANCE	c. Property Insurance if materials and supplies are furnished by the Contractor. The amount of the insurance coverage shall be the value of the materials and supplies or the completed value of the improvement. Hazard or XCU (Explosion, Collapse, Underground) Insurance should be provided if any hazard exists; and	Acknowledged
INSURANCE	d. Automobile Liability Insurance with a combined single limit, or the equivalent of not less than \$1,000,000.0 each accident for bodily injury and property damage, including coverage for owned, hired and non-owned vehicles.	COI - CityofSpokaneWaterDepartment_W34538462.pdf
INSURANCE	e. Professional Liability Insurance with a combined single limit of not less than \$500,000 each claim, incident, or occurrence. This is to cover damages caused by the error, omission, or negligent acts related to the professional services to be provided under this contract. The coverage must remain in effect for at least three (3) years after the contract is completed.	I acknowledge and agree
INSURANCE	There shall be no cancellation, material change, reduction of limits or intent not to renew the insurance coverage(s) without thirty (30) days written notice from the Company or its insurer(s) to the City. As evidence of the insurance coverage(s) required by this Agreement, the Company shall furnish acceptable Certificates of Insurance (COI) upon request by the City. The certificate shall specify the City of Spokane as "Additional Insured" specifically for Company's services under this Agreement, as well as all of the parties who are additional insureds, and include applicable policy endorsements, the thirty (30) day cancellation clause, and the deduction or retention level. The Company shall be financially responsible for all pertinent deductibles, self-insured retentions, and/or self-insurance.	Acknowledged
BID		
BIDDERS DECLARATION	The Bidder submitting this bid certifies that it has examined the site, read and understands the specifications for the above project, and agrees to comply with all applicable federal, state and local laws and regulations. The bidder is advised that by submitting this bid proposal it has acknowledged all bid requirements and certifications contained herein.	I acknowledge and I agree
BID PRICE IS COMPLETE	Bidder acknowledges that the bid price indicated on the Pricing Page includes ALL expenses with regard to this project. No other costs will be allowed over and above the bid price.	I acknowledge and I agree
CONTRACTOR RESPONSIBILITY	Washington State Contractor's Registration Number	KNIMPIC765DG
CONTRACTOR RESPONSIBILITY	U.B.I. Number	604 795 744
CONTRACTORS RESPONSIBILITY	Washington Employment Security Department Number	000-446441-00-0
CONTRACTORS RESPONSIBILITY	Washington Excise Tax Registration Number	605-400-480

CONTRACTORS RESPONSIBILITY	City of Spokane Business Registration Number	Applied for
ADDENDA	Bidder acknowledges receipt of ____ addenda and agrees that their requirements have been included in this bid proposal	1
MISCELLANEOUS	The firm agrees that its Bid will NOT be withdrawn for a minimum of forty-five (90) calendar days after the stated submittal date.	I ACKNOWLEDGE AND AGREE
MISCELLANEOUS	For contracts up to \$150,000.00 including tax, the Contractor may request a 10 percent (10%) retainage in lieu of bond.	I ACKNOWLEDGE AND AGREE
MISCELLANEOUS	If this project is less than \$150,000 - does contract request 10% retainage in lieu of bond?	I ACKNOWLEDGE AND AGREE
MISCELLANEOUS	The bidder submitting this response hereby certifies that, within the three-year period immediately preceding the bid solicitation date for this Project, the bidder is not a "willful" violator, as defined in RCW 49.48.082, of any provision of chapters 49.46, 49.48 or 49.52 RCW, as determined by a final and binding citation and notice of assessment issued by the Department of Labor and Industries or through a civil judgement entered by a court of limited or general jurisdiction. I certify (or declare) under penalty of perjury under the laws of the State of Washington that the foregoing is true and correct.	I ACKNOWLEDGE AND AGREE
MISCELLANEOUS	Individual's Name, Company Name, Address, Email Address & Phone Number for individual/company submitting this bid response.	Luke Olson K&N Electric 415 N. Fancher Road Spokane Valley, WA 99212 lolson@knelectric.com 509-499-3730
MISCELLANEOUS	Name and Email Address for individual authorized to sign a contract.	Janet Schmidlkofer jans@knelectric.com
2	The bid shall be accompanied by a bid bond bound to the City of Spokane, in an amount of not less than five percent (5%) of the total bid amount. Bid bonds must be by a surety company authorized to do business as a surety in Washington State. If the bidder is awarded the contract and fails to enter into a construction contract and/or furnish payment/performance bond(s) and proof of insurance within the required time period, the bid security shall be forfeited to the City of Spokane. Please upload your bid bond here (blank form available under the 'Documents' tab).	Bid Bond - Ascot Surety - Spokane City of Trashrake 2 9-30-2024.pdf
3	If subcontractors will be used, please download the 'Subcontractor List' document from the 'Documents' tab, complete, and upload the completed document here. If subcontractors will be used, failure to upload the completed list may result in a non-responsive determination to this request	Subcontractor List.pdf
Submission of Bids		
#1	Bid Responses shall be submitted electronically through the City of Spokane's bidding portal: <a href="https://spokane.procureware.com">https://spokane.procureware.com</a> on or before the Due Date and time mentioned above. Hard, e-mailed or faxed copies and/or late bids shall not be accepted.	Acknowledged
#2	The City of Spokane is not responsible for bids electronically submitted late. It is the responsibility of the Bidder to be sure the bids are electronically submitted sufficiently ahead of time to be received no later than 1:00 PM Pacific Local Time, on the bid opening date.	Acknowledged
#3	All communication between the Bidder and the City upon receipt of this bid shall be via the "Clarification Tab" within ProcureWare. Any other communication will be considered unofficial and non-binding on the City of Spokane.	Acknowledged
Proprietary Information Disclosure		

#1	All materials submitted to the City in response to this competitive procurement shall become the property of the City.	Acknowledged
#2	All materials received by the City are public records and are subject to being released pursuant to a valid public records request. Washington state law mandates that all documents used, received, or produced by a governmental entity are presumptively public records, and there are few exemptions. RCW Ch. 41.56.	Acknowledged
#3	When responding to this competitive procurement, please consider that what you submit will be a public record. If you believe that some part of your response constitutes legally protected proprietary information, you MUST submit those portions of your response as a separate part of your response, and you MUST label it as "PROPRIETARY INFORMATION." If a valid public records request is then received by the City for this information, you will be given notice and a 10-day opportunity to go to court to obtain an injunction to prevent the City from releasing this part of your response. If no injunction is obtained, the City is legally required to release the records.	Acknowledged
#4	The City will neither look for nor honor any claims of "proprietary information" that are not within the separate part of your response.	Acknowledged
Additional Documents Bidder Would Like To Upload		
#1	Should Bidder Want To Upload Any Additional Document(s) Please Do So Here. ***Please Note: Should Bidder Want To Add More Than One Document, ensure all documents are combined into a single document prior to uploading as bidder would only be able to upload one document here.	Installation and project completion clarification.docx
#2	Should Bidder Want To Upload Any Additional Document(s) Please Do So Here. ***Please Note: Should Bidder Want To Add More Than One Document, ensure all documents are combined into a single document prior to uploading as bidder would only be able to upload one document here.	
#3	Should Bidder Want To Upload Any Additional Document(s) Please Do So Here. ***Please Note: Should Bidder Want To Add More Than One Document, ensure all documents are combined into a single document prior to uploading as bidder would only be able to upload one document here.	
TERMS AND CONDITIONS		
1.	Bidder accepts has read and acknowledges compliance with Terms and Conditions located in the Documents area of this project. If answer is "I do not acknowledge and I do not agree", include requested exception in proposal submittal on separate page and title as "Exception to Terms and Conditions". The City will consider and determine if exception will be accepted.	I acknowledge and agree
2.	Describe exceptions to Terms & Conditions if you marked "I do not acknowledge and I do not agree" above.	

**Pricing Responses**

Group	Reference Number	Description	Type	Unit Of Measure	Quantity	Unit Price	Ext Base Price	Comment
BID								
	1.	Total Project Base Price	Base	Each	1.00	\$1,246,438.37	\$1,246,438.37	
<b>Total Base Bid</b>		\$1,246,438.37						



Letter of submittal for PW ITB 6208-24

To whom it may concern,

The following is our pricing breakdown as requested for this bid:

Pricing Breakdown		
Design	\$	181,206.15
Materials	\$	697,849.62
Equipment	\$	30,268.75
Installation	\$	229,175.00
Other	\$	107,938.85
Total Price	\$	1,246,438.37

Feel free to contact me if you have any questions.

Thank you,

Luke Olson

Project Manager

K&N an impel company

Office – 509-838-8000

Direct – 509-344-5233

[lolson@knelectric.com](mailto:lolson@knelectric.com)

A handwritten signature in blue ink, appearing to read 'Luke Olson', with a long, sweeping horizontal line extending to the right.

We, ATLAS-SSI Inc., propose to design and provide the following equipment:

One (1) ATLAS-SSI Landy Trash Rake

The complete scope of supply follows:

## **1.0 SYSTEM OVERVIEW**

### **1.1 General Description**

The ATLAS-SSI Landy Rake consists of a hydraulically actuated gripper suspended from a trolley. The trolley traverses an overhead monorail track until the gripper is positioned above a bar screen (trash rack). The gripper is then lowered on steel cables until the gripper teeth engage the bars of the bar screen. As the gripper slides down the face of the bar screen with its teeth engaged, it gathers floating and impinged debris. Upon reaching the bottom of the bar screen, the gripper closes tightly, thereby trapping the debris for lifting and transport. The gripper, with its collected debris, is then hoisted up to the monorail and transported to the designated debris disposal site. Once at the dump site, the gripper opens to release the debris.



**Typical Rake system overview**

Under normal conditions, the Rake runs either automatically or manually. If desired, an automatic cleaning cycle may be initiated: (1) when a preset time has elapsed, (2) because an automatic cleaning cycle is requested through a pushbutton start, or (3) according to site-specific criteria. The Rake is also capable of manual operation through a remote pushbutton control unit.

## 1.2 Scope of Supply

The proposed installation consists of a single Rake system. The system is comprised of the following components:

- One (1) straight monorail **drive track**
- One (1) hydraulically actuated **gripper**
- One (1) weather-resistant enclosed **trolley**
- Three (3) drive-track-supporting **columns**
- Three (3) drive-track-supporting **portals**
- One (1) dump site **portal**
- One (1) local **control panel**
- Installation instructions and drawings
- Operation and Maintenance manual
- Two (2) wireless remote-control units

## 1.3 Equipment Summary

Rake model	R66
Debris lifting capacity	2,000 lb.
Operating depth	Approximately 42'-9"
Gripper clearance above dump slab	10'-0"
Depth of screens below slab	Approximately 32'-9"
Track length	125'
Active trolley travel length	125'
Festoon cable storage	Separate Festoon Track
Gripper width	6'-11"
Weight of gripper	2,359 lb.
Drive speed	100 ft/min
Hoist speed	50 ft/min
Weight of trolley	2,315 lb.
Hoist motor power	10 HP
Drive motor power	1.0 HP
Hydraulic unit power	3 HP
Standard power supply	480 VAC
Control voltage	24 VDC
Auxiliary control voltage	120 VAC



## 1.4 Component Details

### 1.4.1 Bar Screens

The existing bar screens currently situated at Powerhouse #2 will be reused.

### 1.4.2 Drive Track

The installation will require a straight overhead monorail drive track, approximately 125' long. A separate adjacent track for festoon cable storage will be included.

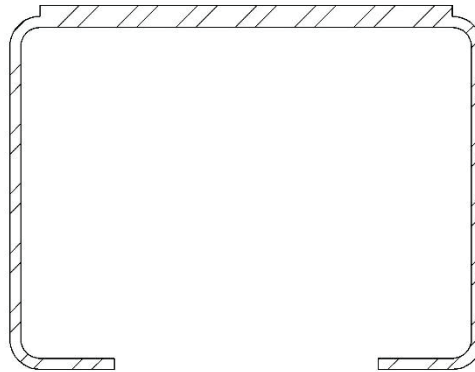

**Monorail track cross section.**

The track will be fabricated from structural carbon steel plate, formed into a C-channel shape. The lower interior flanges of the channel provide the surface upon which the trolley wheels roll. The track is fabricated in sections, joined together by splice plates, and leveled at the support columns using threaded suspension rods. After fabrication, the track will receive a hot-dip galvanized coating.

### 1.4.3 Gripper

The bar screens are cleaned by a submersible-duty, hydraulically actuated gripper, approximately 6'-11" wide, designed especially for debris removal and transport. The gripper consists of a fixed rear jaw with teeth that engage and mesh with the bar screens, and a rotating front jaw curved to capture and retain debris. The gripper is opened and closed by two submersible duty hydraulic cylinders, connected to the hydraulic power unit by heavy-duty hoses and tubing. The gripper is raised and lowered from the trolley by two steel cables (wire ropes) and slides up and down the bar screens on anti-friction polymer wear plates. The gripper body will be fabricated from hot-dip galvanized carbon steel. The wire ropes will be stainless steel.

#### 1.4.4 Trolley

The gripper is transported along the monorail drive track by a weather-resistant enclosed trolley. Mounted on the top of the trolley in such a position to be sheltered inside the monorail track are:

- the drive motor and drive gear reducer
- traveling wheels for suspending and propelling the trolley
- lateral stabilizing wheels to steer the trolley along the monorail track.
- proximity switches for detecting important travel locations.

Sealed inside the trolley are:

- the hoist motor, hoist gear reducer, and hoist cable drums
- the hydraulic unit and hydraulic hose drum
- all hydraulic control valves, pressure switches, and regulators
- limit switches for monitoring the gripper position under the trolley.
- sensors for detecting slack cables and cable drum disturbances.

#### 1.4.5 Columns

The track is suspended from a series of support assemblies, each typically constructed from carbon rectangular steel tubing. For this installation, the following supports are required; three (3) monorail columns will be required, each approximately 21'-8<sup>9</sup>/<sub>16</sub>" tall, three (3) monorail supporting portals, each approximately 21'-8<sup>9</sup>/<sub>16</sub>" tall, and one (1) dump site portal approximately 21'-2<sup>9</sup>/<sub>16</sub>" tall.



### 1.4.6 Control Panel

The Atlas-Landy Rake will be operated from the Rake control panel, manufactured according to the following typical specifications:

Enclosure type	NEMA 4X
Dimensions	48" tall × 60" wide × 16" deep
Power feed	480VAC / 3 phase / 60 Hz
Logic signal voltage	24 VDC
Auxiliary control voltage	120 VAC
Touchscreen type	10" color
PLC type	Allen-Bradley

The Rake will be manually operated with the use of a handheld pushbutton controller.

### 1.5 Start-up and Commissioning

Upon completion of installation of Rake, an Atlas-SSI technician will work with the owner and contractor to perform start-up and testing. A total of five (5) days have been included.

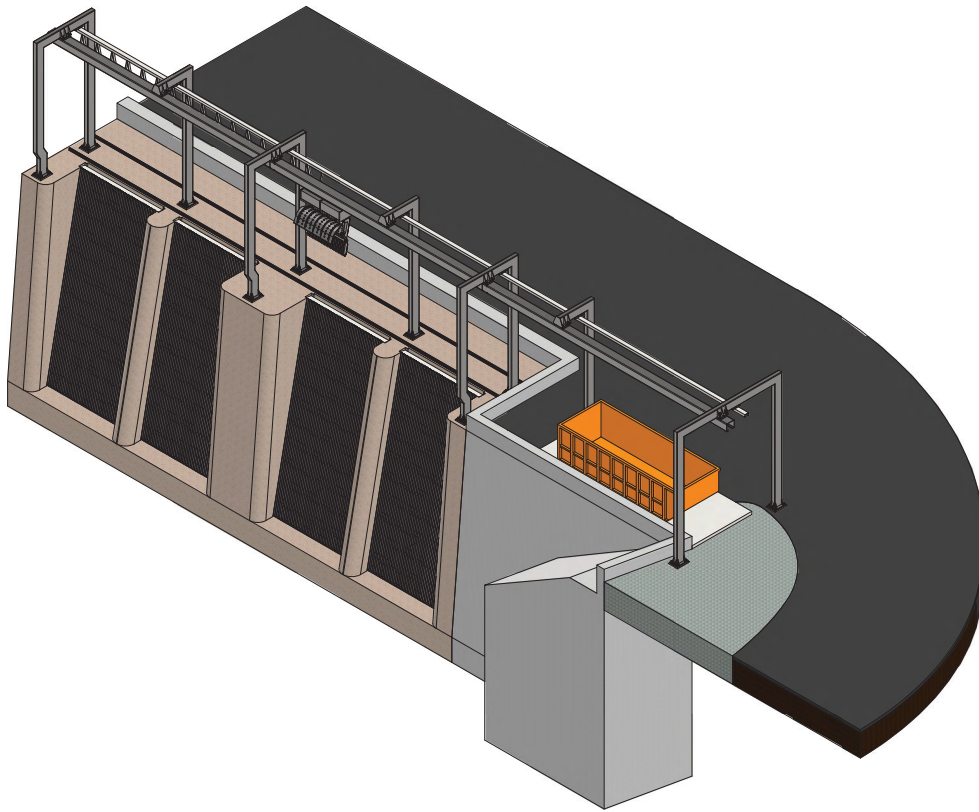

**ATLAS SSI**  
 602 McFERRISON DRIVE  
 MOUNTAIN VIEW, MS 38964  
 PHONE: 601-587-4311

**SPOKANE POWERHOUSE #2**  
**LANDY RAKE GENERAL ARRANGEMENT**  
**OVERVIEW**

REV.	DATE	DESCRIPTION	DESIGNED BY	DATE	SCALE	SHEET	OF	NO.
			KSM	9-26-2014	1:75	1	OF 6	0

**SP2-GA-005**    **0**

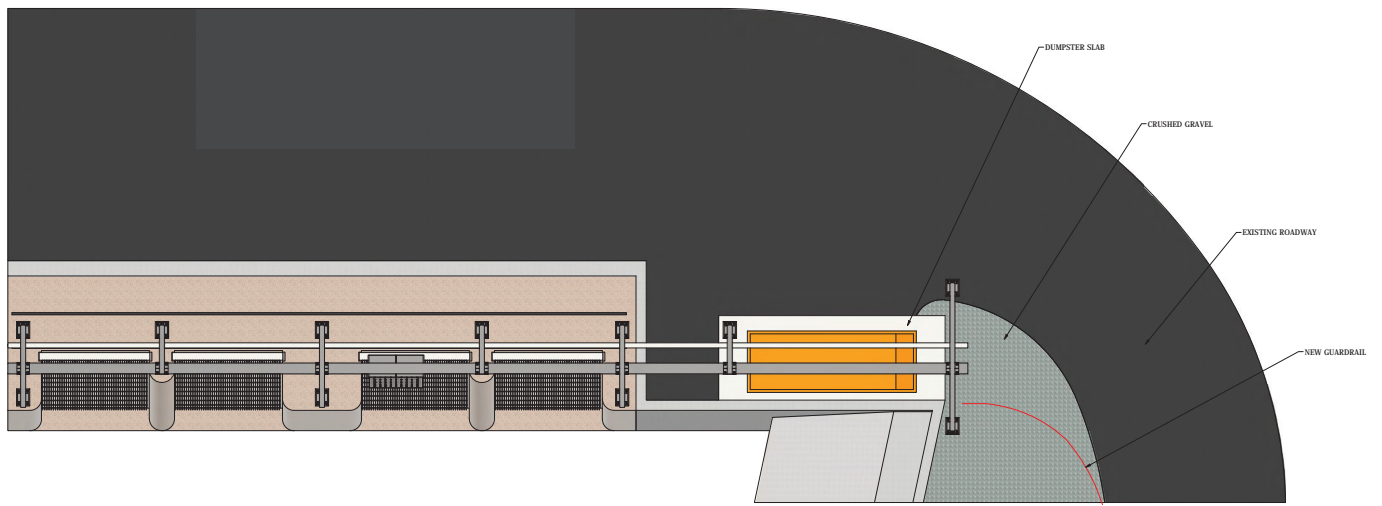

**ATLAS SSI** 602 McFERRISON DRIVE  
MOUNTAIN VIEW, MS 38954  
PHONE: 601-587-6511

**SPOKANE POWERHOUSE #2**  
**LANDY RAKE GENERAL ARRANGEMENT**  
**PLAN VIEW**

REV.	DATE	DESCRIPTION	SCALE: 1/8"	SHEET 2 OF 6	SP2-GA-005	0
------	------	-------------	-------------	--------------	------------	---



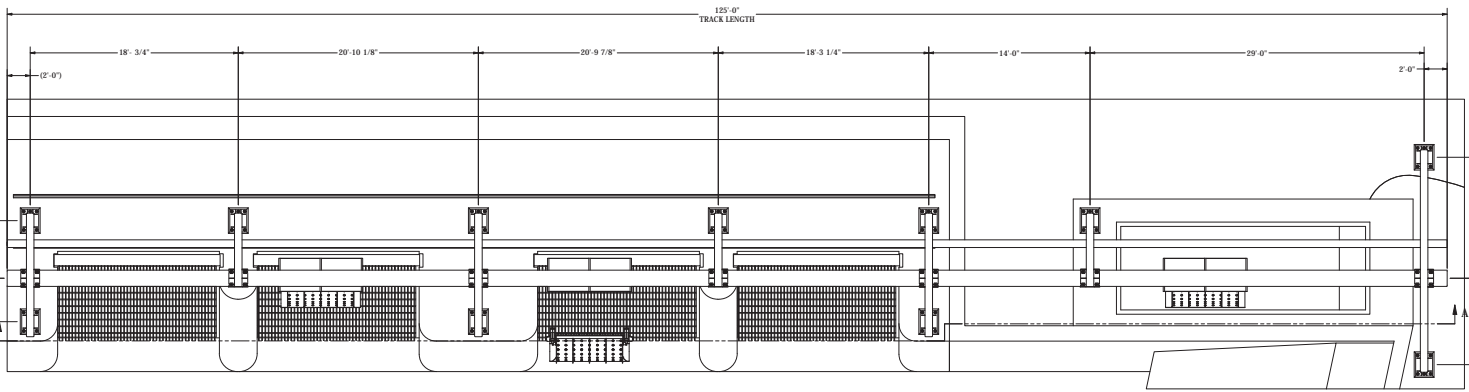

**ATLAS SSI** 602 McFERRISON DRIVE  
MONTICELLO, MS 38753  
PHONE: 601-587-4511

**SPOKANE POWERHOUSE #2**  
**LANDY RAKE GENERAL ARRANGEMENT**  
**TRACK AND COLUMN LOCATION**

DESIGNED BY	KSM	DATE	9-28-2014	PROJECT NO.	
CHECKED BY		SCALE		SHEET	4 OF 6
REV.	DATE	DESCRIPTION	SCALE: 1/32	SHEET 4 OF 6	

**SP2-GA-005**     **0**

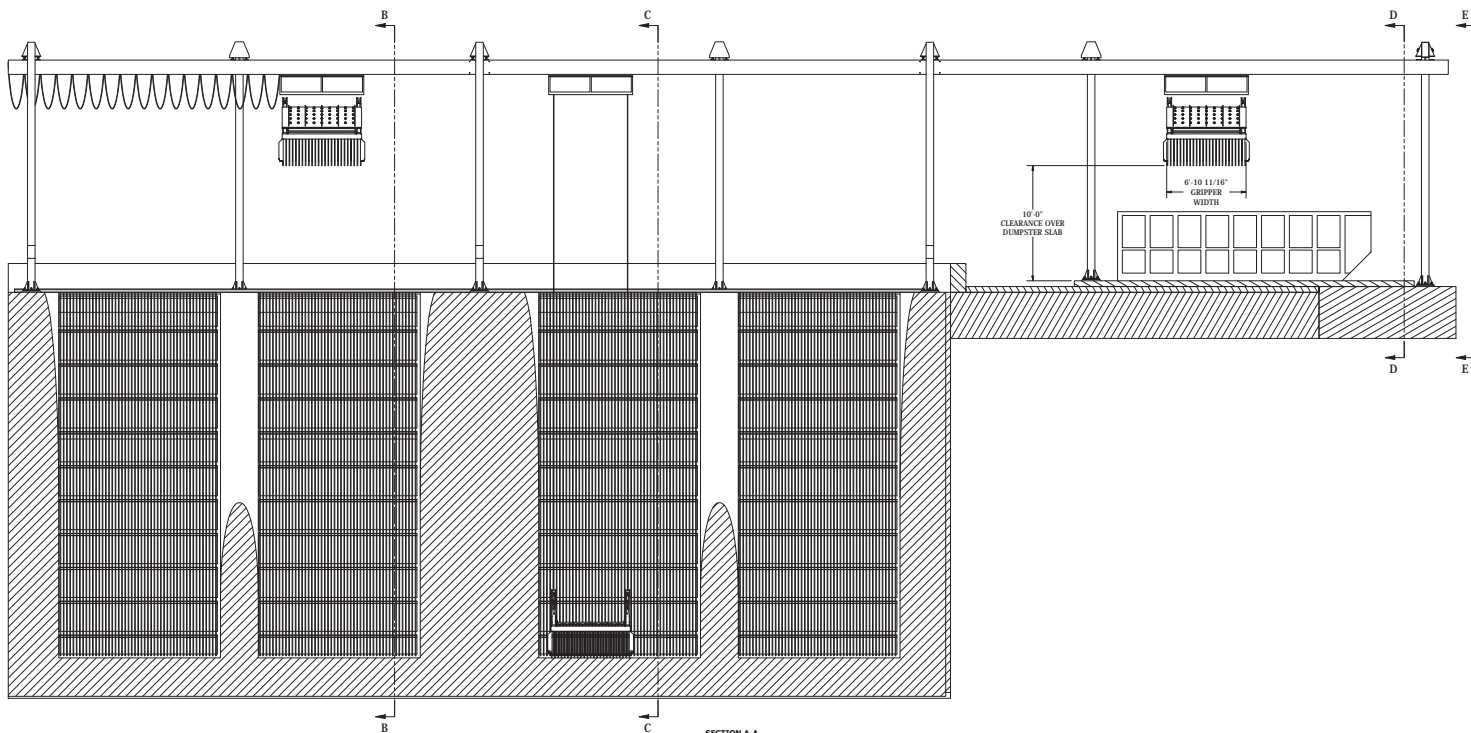

SECTION A-A  
SCALE 1 : 50

**ATLAS SSI** 402 McFERRISON DRIVE  
MONTICELLO, MS 38754  
PHONE: 601-587-4511

**SPOKANE POWERHOUSE #2**  
**LANDY RAKE GENERAL ARRANGEMENT**  
**FRONT SECTION**

REV.	DATE	DESCRIPTION	SCALE: 1 : 50	SHEET 3 OF 6	SP2-GA-005	0
------	------	-------------	---------------	--------------	------------	---



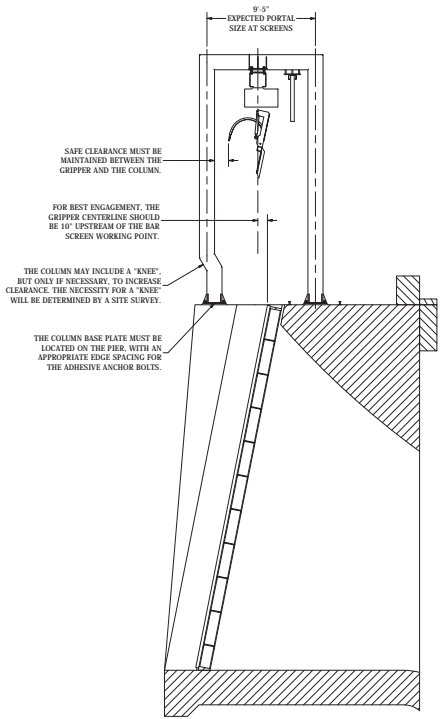

SECTION B-B  
SCALE 1 : 50

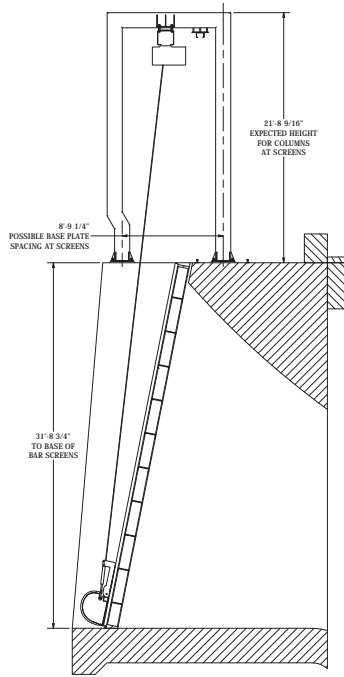

SECTION C-C  
SCALE 1 : 50

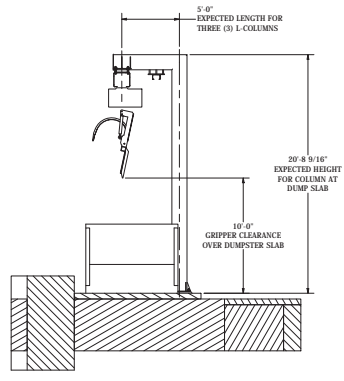

SECTION D-D  
SCALE 1 : 50

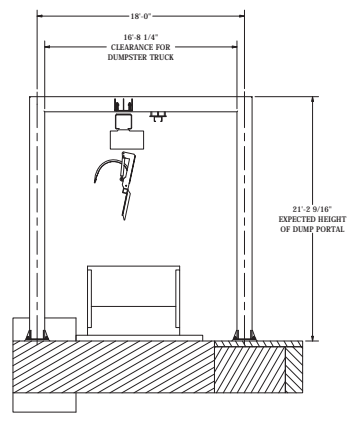

VIEW E-E  
SCALE 1 : 50

SAFE CLEARANCE MUST BE MAINTAINED BETWEEN THE GRIPPER AND THE COLUMN.

FOR BEST ENGAGEMENT, THE GRIPPER CENTERLINE SHOULD BE 10' UPSTREAM OF THE BAR SCREEN WORKING POINT.

THE COLUMN MAY INCLUDE A "KNEE" BUT ONLY IF NECESSARY TO INCREASE CLEARANCE. THE NECESSITY FOR A "KNEE" WILL BE DETERMINED BY A SITE SURVEY.

THE COLUMN BASE PLATE MUST BE LOCATED ON THE PIER, WITH AN APPROPRIATE EDGE SPACING FOR THE ADHESIVE ANCHOR BOLTS.

		602 McFERRISON DRIVE MONTICELLO, MS 39064 PHONE: 601-987-6511	
		SPOKANE POWERHOUSE #2 LANDY RAKE GENERAL ARRANGEMENT	
		SECTION VIEWS	
DESIGNED BY	KSM	DATE	9-26-2004
CHECKED BY	CSH	SCALE	1 : 50
REV.	DATE	DESCRIPTION	SHEET 6 OF 6
			SP2-GA-005
			0

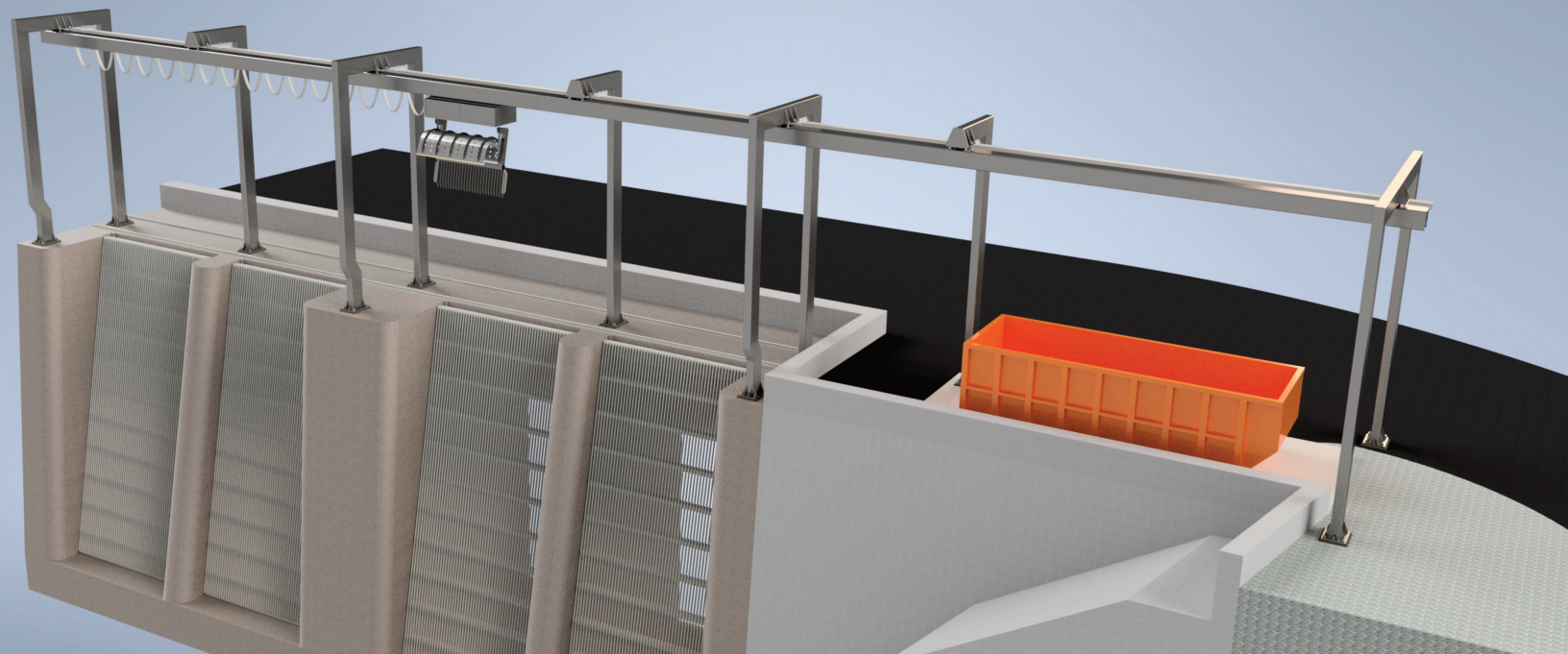

I acknowledged the following statement, as it was the only option to select when filling out the bid response:

"The bidder agrees to start the work under this contract within ten (10) days of the Notice to Proceed and to substantially complete the specified work six (6) months."

The previous statement contradicts the following statement which we understand to be the true requirement:

"Installation shall be scheduled for between July 15 and September 15, 2025, to accommodate for low river flows and reduced generation."

**BID BOND**

We, K&N, an Impel Company as Principal, and Ascot Surety & Casualty Company as Surety, are held and firmly bound unto the CITY OF SPOKANE, a Washington State municipal corporation, in the penal sum of FIVE PERCENT (5%) OF THE TOTAL AMOUNT BID, for the payment of which we jointly and severally bind ourselves, and our legal representatives and successors.

THE CONDITIONS OF THE OBLIGATION are that if the City of Spokane shall make timely award to the Principal for the **SPOKANE WATER DEPARTMENT POWERHOUSE 2 TRASH RAKE REPLACEMENT PROJECT** according to the terms of the bid made by the Principal; and the Principal shall, within the specified time, enter into a contract with the City of Spokane and furnish bond(s) acceptable to the City, if required, then this obligation shall be null and void; otherwise it shall remain in full force and effect; but in no event will the surety's liability exceed this bond's face amount.

SIGNED AND SEALED on September 27, 2024

AS PRINCIPAL

K&N, an Impel Company



By: *Bob Schindler*  
Title: CONTROLLER

A valid POWER OF ATTORNEY must accompany this bond.

Ascot Surety & Casualty Company  
AS SURETY

By: *Jaren A. Marx*  
Jaren A. Marx Attorney in Fact

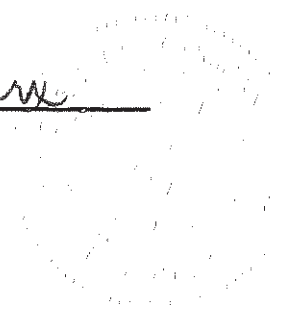

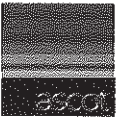

## Power of Attorney

**KNOW ALL MEN BY THE PRESENTS:**

That Ascot Surety & Casualty Company and Ascot Insurance Company, each a corporation organized and existing under the laws of the State of Colorado (the "Companies"), do hereby constitute and appoint:

Marina Tapia, Edward C. Spector, Ethan Spector, B. Aleman, Sandra Corona, Aidan Smock, D. Garcia, Sarah Campbell, Jennifer Ochs, Erin Brown, Jaren A Marx, Rachel A Mullen, Michelle Haase, Simone Gerhard, Alysha Mendoza and KD Wapato

of Los Angeles, CA (city, state) and each its true and lawful Attorney(s)-in-Fact, with full authority to sign, execute, seal, acknowledge and deliver for, and on its behalf, and as its act and deed any place within the United States, or, if the following line is filled in, only within the area and up to the amount therein designated, any and all bonds, undertakings, recognizances, and other contracts of indemnity or writings obligatory in the nature thereof, issued in the course of its surety business, and to bond the Companies as follows:

**Any such obligations in the United States not to exceed \$50,000,000.00.**

The Companies hereby ratify and confirm all and whatsoever said Attorney(s)-in-fact may lawfully do in the premises by virtue of these presents. These appointments are made under and by authority Resolutions adopted by the Board of Directors of the Companies, which resolutions are still in effect:

RESOLVED, that any of the Chief Executive Office, the Chief Operating Officer or the Chief Underwriting Officer, acting in conjunction with the head of the surety business line for the Corporation (each an Authorized Individual\* and, collectively, the Authorized Individuals\*), are authorized to jointly appoint one or more attorneys-in-fact to represent and act for and on behalf of the Corporation in the transaction of the Corporation's surety business to execute (under the common seal of the Corporation if appropriate) bonds, undertakings, recognizances and other contracts of indemnity and writings obligatory in the nature thereof;

RESOLVED, that in conjunction with the Corporation's transaction of surety business the signatures and attestations of the Authorized Individuals and the seal of the Corporation be affixed to any such Power of Attorney or to any certificate relating thereto (electronic or otherwise) by facsimile and any such Power of Attorney or certificate bearing such facsimile signatures or facsimile seals (electronic or otherwise) shall be valid and bonding upon the Corporation when so affixed with respect to any bond, undertaking, recognizance or tolher contract of indemnity or writing obligatory in the nature thereof;

RESOLVED, that in connection with the Corporation's transaction of surety business, the facsimile electronic or mechanically reproduced signature of any Authorized Individual, whether made heretofore or hereafter, whenever appearing upon a copy of any Power of Attorney of the Corporation, with signatures

IN WITNESS WHEREOF, the Companies have caused these presents with the respective corporate seals and to be executed by the individuals named below who are duly authorized and empowered to execute the Power of Attorney on the Companies' behalf, this 1<sup>st</sup> day of July 2024.



ASCOT SURETY & CASUALTY COMPANY  
 ASCOT INSURANCE COMPANY

Matthew Conrad Kramer (Chief Executive Officer)

Tara North (Executive Vice President, Surety)

STATE OF CONNECTICUT )  
 COUNTY OF FAIRFIELD ) ss.

On this 1<sup>st</sup> day of July 2024, before me came the above named Chief Executive Officer of each Ascot Surety & Casualty Company and Ascot Insurance Company and the head of the surety business line for each of Ascot Surety & Casualty Company and Ascot Insurance Company, to me personally known to be the individuals described herein, and acknowledged that the seals affixed to the preceding instrument and the corporate seals of each Ascot Surety & Casualty Company and Ascot Insurance Company, and that the said corporate seals and signatures were duly affixed and subscribed to said instrument by the authority and direction of said Companies.

**KSENIA E. GUSEVA**  
 NOTARY PUBLIC  
 STATE OF CONNECTICUT  
 My Commission Expires June 30, 2029

Notary Public Ksenia E Guseva  
 My commission expires on June 30, 2029

I, the undersigned Secretary of the Company, do hereby certify that the foregoing excerpts of the Resolution adopted by the Board of Directors of the Companies, and the Power of Attorney issued pursuant thereto, are true and correct, and further certify that both the Resolution and the Power of Attorney are still in full force and effect.

This Certificate may be signed by facsimile under and by the authority of the following resolution of the Board of Directors of the Companies.

RESOLVED, that in connection with the Corporation's transaction of surety business the signatures and attestations of the Authorized Individuals and the seal of the Corporation be affixed to any such Power of Attorney or to any certificate relating thereto (electronic or otherwise) by facsimile and any such Power of Attorney of certificate bearing such facsimile signatures or facsimile seal (electronic or otherwise) shall be valid and binding upon the Corporation when so affixed with respect to any bond, undertaking, recognizances or other contract of indemnity or writing obligatory in the nature thereof;

IN WITNESS WHEREOF; I have hereunto set my hand and affixed the seal of the Companies, this 27th day of September, 2024.

ASCOT SURETY & CASUALTY COMPANY  
 ASCOT INSURANCE COMPANY

John Gill, Secretary

**SUBCONTRACTOR LIST**

**PROJECT NAME:** Upriver Dam Hydroelectric Project - Engineer, Furnish and Install a replacement  
Powerhouse #2 Trash Rake System

**IMPORTANT: REFER TO SECTION 5.2.1 OF THE SUPPLEMENTAL CONDITIONS FOR  
INSTRUCTIONS ON COMPLETING THE SUBCONTRACTOR LIST (use additional pages if  
necessary):**

**CONTRACTOR/SUPPLIER** Atlas SSI

TYPE OF WORK/BID ITEM Design, manufacture, and deliver trash rake system

AMOUNT \$667,000.00

CONTRACTOR'S REGISTRATION NO. CL.65842

**CONTRACTOR/SUPPLIER** Power City Electric

TYPE OF WORK/BID ITEM Electrical installation

AMOUNT \$48,340.00

CONTRACTOR'S REGISTRATION NO. POWERCE994BA

**CONTRACTOR/SUPPLIER** Kirwin Construction

TYPE OF WORK/BID ITEM Mechanical/Structural installation

AMOUNT \$85,000.00

CONTRACTOR'S REGISTRATION NO. KIRWICL761DA

**CONTRACTOR/SUPPLIER** \_\_\_\_\_

TYPE OF WORK/BID ITEM \_\_\_\_\_

AMOUNT \_\_\_\_\_

CONTRACTOR'S REGISTRATION NO. \_\_\_\_\_

3 NO SUBCONTRACTORS WILL BE USED ON THIS PROJECT



< Business Lookup

## License Information:

[New search](#) [Back to results](#)

**Entity name:** PUMPTECH, LLC

**Business name:** K&N, AN IMPEL COMPANY

**Entity type:** Limited Liability Company

**UBI #:** 604-795-744

**Business ID:** 001

**Location ID:** 0003

**Location:** Active

**Location address:** 415 N FANCHER RD  
SPOKANE VALLEY WA 99212-1059

**Mailing address:** 12020 SE 32ND ST  
STE 2  
BELLEVUE WA 98005-4135



### Excise tax and reseller permit status:

[Click here](#)

### Secretary of State status:

[Click here](#)

## Endorsements

Endorsements held at this lo	License #	Count	Details	Status	Expiration da	First issuance
Spokane General Business - Non-Resident				Active	Sep-30-2025	Sep-30-2024
Spokane Valley General Business				Active	Feb-28-2025	Feb-07-2024

## Governing People

*May include governing people not registered with Secretary of State*

### Governing people

### Title

STAAB, DOUG

## Registered Trade Names

Registered trade names	Status	First issued
ALASKA ROTEQ, AN IMPEL COMPANY	Active	Jan-24-2024
ALPHA SOUTHWEST, AN IMPEL COMPANY	Active	Jul-25-2023





Registered trade names	Status	First issued
FROST ENGINEERING, A DIVISION OF PUMPTECH LLC	Active	Jun-23-2022
K&N, AN IMPEL COMPANY	Active	Nov-06-2023
PIPESTONE EQUIPMENT, AN IMPEL COMPANY	Active	Jul-25-2023
PUMPTECH INTEGRATION	Active	Feb-21-2024
PUMPTECH LLC, INSTRUMENTATION	Active	Jan-24-2024
PUMPTECH LLC, INTEGRATION	Active	Jan-24-2024
PUMPTECH, LLC	Active	Sep-23-2021

[View Additional Locations](#)

The Business Lookup information is updated nightly. Search date and time:  
10/7/2024 12:04:14 PM



## Contact us

How are we doing?

**Take our survey!**

Don't see what you expected?

**Check if your browser is supported**





# CERTIFICATE OF LIABILITY INSURANCE

DATE (MM/DD/YYYY)  
08/26/2024

THIS CERTIFICATE IS ISSUED AS A MATTER OF INFORMATION ONLY AND CONFERS NO RIGHTS UPON THE CERTIFICATE HOLDER. THIS CERTIFICATE DOES NOT AFFIRMATIVELY OR NEGATIVELY AMEND, EXTEND OR ALTER THE COVERAGE AFFORDED BY THE POLICIES BELOW. THIS CERTIFICATE OF INSURANCE DOES NOT CONSTITUTE A CONTRACT BETWEEN THE ISSUING INSURER(S), AUTHORIZED REPRESENTATIVE OR PRODUCER, AND THE CERTIFICATE HOLDER.

**IMPORTANT:** If the certificate holder is an ADDITIONAL INSURED, the policy(ies) must have ADDITIONAL INSURED provisions or be endorsed. If SUBROGATION IS WAIVED, subject to the terms and conditions of the policy, certain policies may require an endorsement. A statement on this certificate does not confer rights to the certificate holder in lieu of such endorsement(s).

<b>PRODUCER</b> Willis Towers Watson Northeast, Inc. c/o 26 Century Blvd P.O. Box 305191 Nashville, TN 372305191 USA	<b>CONTACT NAME:</b> WTW Certificate Center <b>PHONE (A/C. No. Ext):</b> 1-877-945-7378 <b>E-MAIL ADDRESS:</b> certificates@wtwco.com		<b>FAX (A/C. No.):</b> 1-888-467-2378																				
	<table border="1"> <thead> <tr> <th colspan="2">INSURER(S) AFFORDING COVERAGE</th> <th>NAIC #</th> </tr> </thead> <tbody> <tr> <td>INSURER A:</td> <td>The Charter Oak Fire Insurance Company</td> <td>25615</td> </tr> <tr> <td>INSURER B:</td> <td>Travelers Indemnity Company of CT</td> <td>25682</td> </tr> <tr> <td>INSURER C:</td> <td>Travelers Property Casualty Company of Ame</td> <td>25674</td> </tr> <tr> <td>INSURER D:</td> <td>Travelers Property Casualty Insurance Comp</td> <td>36161</td> </tr> <tr> <td>INSURER E:</td> <td>Lloyds Syndicate 2987</td> <td>C0978</td> </tr> <tr> <td>INSURER F:</td> <td></td> <td></td> </tr> </tbody> </table>			INSURER(S) AFFORDING COVERAGE		NAIC #	INSURER A:	The Charter Oak Fire Insurance Company	25615	INSURER B:	Travelers Indemnity Company of CT	25682	INSURER C:	Travelers Property Casualty Company of Ame	25674	INSURER D:	Travelers Property Casualty Insurance Comp	36161	INSURER E:	Lloyds Syndicate 2987	C0978	INSURER F:	
INSURER(S) AFFORDING COVERAGE		NAIC #																					
INSURER A:	The Charter Oak Fire Insurance Company	25615																					
INSURER B:	Travelers Indemnity Company of CT	25682																					
INSURER C:	Travelers Property Casualty Company of Ame	25674																					
INSURER D:	Travelers Property Casualty Insurance Comp	36161																					
INSURER E:	Lloyds Syndicate 2987	C0978																					
INSURER F:																							
<b>INSURED</b> PumpTech LLC dba K&N, An Impel Company 12020 SE 32nd St, Suite 2 Bellevue, WA 98005																							

**COVERAGES**

CERTIFICATE NUMBER: W34538462

REVISION NUMBER:

THIS IS TO CERTIFY THAT THE POLICIES OF INSURANCE LISTED BELOW HAVE BEEN ISSUED TO THE INSURED NAMED ABOVE FOR THE POLICY PERIOD INDICATED. NOTWITHSTANDING ANY REQUIREMENT, TERM OR CONDITION OF ANY CONTRACT OR OTHER DOCUMENT WITH RESPECT TO WHICH THIS CERTIFICATE MAY BE ISSUED OR MAY PERTAIN, THE INSURANCE AFFORDED BY THE POLICIES DESCRIBED HEREIN IS SUBJECT TO ALL THE TERMS, EXCLUSIONS AND CONDITIONS OF SUCH POLICIES. LIMITS SHOWN MAY HAVE BEEN REDUCED BY PAID CLAIMS.

INSR LTR	TYPE OF INSURANCE	ADDL INSD	SUBR WVD	POLICY NUMBER	POLICY EFF (MM/DD/YYYY)	POLICY EXP (MM/DD/YYYY)	LIMITS
A	<input checked="" type="checkbox"/> COMMERCIAL GENERAL LIABILITY <input type="checkbox"/> CLAIMS-MADE <input checked="" type="checkbox"/> OCCUR GEN'L AGGREGATE LIMIT APPLIES PER: <input checked="" type="checkbox"/> POLICY <input checked="" type="checkbox"/> PRO-JECT <input type="checkbox"/> LOC OTHER:	Y	Y	Y-630-331D063A-COF-24	08/26/2024	08/26/2025	EACH OCCURRENCE \$ 1,000,000 DAMAGE TO RENTED PREMISES (Ea occurrence) \$ 300,000 MED EXP (Any one person) \$ 5,000 PERSONAL & ADV INJURY \$ 1,000,000 GENERAL AGGREGATE \$ 2,000,000 PRODUCTS - COMP/OP AGG \$ 2,000,000
B	<b>AUTOMOBILE LIABILITY</b> <input checked="" type="checkbox"/> ANY AUTO <input type="checkbox"/> OWNED AUTOS ONLY <input type="checkbox"/> HIRED AUTOS ONLY <input type="checkbox"/> SCHEDULED AUTOS <input type="checkbox"/> NON-OWNED AUTOS ONLY			810-1Y037218-24-14-G	08/26/2024	08/26/2025	COMBINED SINGLE LIMIT (Ea accident) \$ 1,000,000 BODILY INJURY (Per person) \$ BODILY INJURY (Per accident) \$ PROPERTY DAMAGE (Per accident) \$
C	<input checked="" type="checkbox"/> UMBRELLA LIAB <input checked="" type="checkbox"/> EXCESS LIAB <input checked="" type="checkbox"/> OCCUR <input type="checkbox"/> CLAIMS-MADE DED RETENTION \$			EX-4Y788505-24-14	08/26/2024	08/26/2025	EACH OCCURRENCE \$ 10,000,000 AGGREGATE \$ 10,000,000
D	<b>WORKERS COMPENSATION AND EMPLOYERS' LIABILITY</b> ANY PROPRIETOR/PARTNER/EXECUTIVE OFFICER/MEMBER EXCLUDED? (Mandatory in NH) If yes, describe under DESCRIPTION OF OPERATIONS below	Y/N No	N/A	UB-4Y056146-24-14-G	08/26/2024	08/26/2025	<input checked="" type="checkbox"/> PER STATUTE <input type="checkbox"/> OTH-ER E.L. EACH ACCIDENT \$ 1,000,000 E.L. DISEASE - EA EMPLOYEE \$ 1,000,000 E.L. DISEASE - POLICY LIMIT \$ 1,000,000
E	<b>Architects &amp; Engineers Professional Liability</b>			KAE 000-1022	09/26/2023	09/26/2024	Limit: \$3,000,000

DESCRIPTION OF OPERATIONS / LOCATIONS / VEHICLES (ACORD 101, Additional Remarks Schedule, may be attached if more space is required)

City of Spokane - Water Department is an Additional Insured to the extent provided by the policy language or endorsement issued or approved by the insurance carrier. Insurance provided to Additional Insured(s) is primary and non-contributory as per the attached endorsements or policy language. Waiver of Subrogation applies per attached endorsement(s) or policy language.

**CERTIFICATE HOLDER****CANCELLATION**

City of Spokane - Water Department 808 W Spokane Falls Blvd Spokane, WA 99201	SHOULD ANY OF THE ABOVE DESCRIBED POLICIES BE CANCELLED BEFORE THE EXPIRATION DATE THEREOF, NOTICE WILL BE DELIVERED IN ACCORDANCE WITH THE POLICY PROVISIONS.  AUTHORIZED REPRESENTATIVE <i>Patricia A. Fony</i>
---	--

© 1988-2016 ACORD CORPORATION. All rights reserved.

**THIS ENDORSEMENT CHANGES THE POLICY. PLEASE READ IT CAREFULLY.**

**BLANKET ADDITIONAL INSURED**  
**(Includes Products-Completed Operations If Required By Contract)**

This endorsement modifies insurance provided under the following:  
 COMMERCIAL GENERAL LIABILITY COVERAGE PART

**PROVISIONS**

The following is added to **SECTION II – WHO IS AN INSURED**:

Any person or organization that you agree in a written contract or agreement to include as an additional insured on this Coverage Part is an insured, but only:

- a. With respect to liability for "bodily injury" or "property damage" that occurs, or for "personal injury" caused by an offense that is committed, subsequent to the signing of that contract or agreement and while that part of the contract or agreement is in effect; and
- b. If, and only to the extent that, such injury or damage is caused by acts or omissions of you or your subcontractor in the performance of "your work" to which the written contract or agreement applies. Such person or organization does not qualify as an additional insured with respect to the independent acts or omissions of such person or organization.

The insurance provided to such additional insured is subject to the following provisions:

- a. If the Limits of Insurance of this Coverage Part shown in the Declarations exceed the minimum limits required by the written contract or agreement, the insurance provided to the additional insured will be limited to such minimum required limits. For the purposes of determining whether this limitation applies, the minimum limits required by the written contract or agreement will be considered to include the minimum limits of any Umbrella or Excess liability coverage required for the additional insured by that written contract or agreement. This provision will not increase the limits of insurance described in Section III – Limits Of Insurance.
- b. The insurance provided to such additional insured does not apply to:

(1) Any "bodily injury", "property damage" or "personal injury" arising out of the providing, or failure to provide, any professional architectural, engineering or surveying services, including:

- (a) The preparing, approving, or failing to prepare or approve, maps, shop drawings, opinions, reports, surveys, field orders or change orders, or the preparing, approving, or failing to prepare or approve, drawings and specifications; and
- (b) Supervisory, inspection, architectural or engineering activities.

(2) Any "bodily injury" or "property damage" caused by "your work" and included in the "products-completed operations hazard" unless the written contract or agreement specifically requires you to provide such coverage for that additional insured during the policy period.

c. The additional insured must comply with the following duties:

(1) Give us written notice as soon as practicable of an "occurrence" or an offense which may result in a claim. To the extent possible, such notice should include:

- (a) How, when and where the "occurrence" or offense took place;
- (b) The names and addresses of any injured persons and witnesses; and
- (c) The nature and location of any injury or damage arising out of the "occurrence" or offense.

(2) If a claim is made or "suit" is brought against the additional insured:

## COMMERCIAL GENERAL LIABILITY

- (a) Immediately record the specifics of the claim or "suit" and the date received; and
- (b) Notify us as soon as practicable and see to it that we receive written notice of the claim or "suit" as soon as practicable.
- (3) Immediately send us copies of all legal papers received in connection with the claim or "suit", cooperate with us in the investigation or settlement of the claim or defense against the "suit", and otherwise comply with all policy conditions.
- (4) Tender the defense and indemnity of any claim or "suit" to any provider of other insurance which would cover such additional insured for a loss we cover. However, this condition does not affect whether the insurance provided to such additional insured is primary to other insurance available to such additional insured which covers that person or organization as a named insured as described in Paragraph 4., Other Insurance, of Section IV – Commercial General Liability Conditions.

**c. Method Of Sharing**

If all of the other insurance permits contribution by equal shares, we will follow this method also. Under this approach each insurer contributes equal amounts until it has paid its applicable limit of insurance or none of the loss remains, whichever comes first.

If any of the other insurance does not permit contribution by equal shares, we will contribute by limits. Under this method, each insurer's share is based on the ratio of its applicable limit of insurance to the total applicable limits of insurance of all insurers.

**d. Primary And Non-Contributory Insurance If Required By Written Contract**

If you specifically agree in a written contract or agreement that the insurance afforded to an insured under this Coverage Part must apply on a primary basis, or a primary and non-contributory basis, this insurance is primary to other insurance that is available to such insured which covers such insured as a named insured, and we will not share with that other insurance, provided that:

- (1) The "bodily injury or "property damage" for which coverage is sought occurs; and
- (2) The "personal and advertising injury" for which coverage is sought is caused by an offense that is committed;

subsequent to the signing of that contract or agreement by you.

**5. Premium Audit**

- a. We will compute all premiums for this Coverage Part in accordance with our rules and rates.
- b. Premium shown in this Coverage Part as advance premium is a deposit premium only. At the close of each audit period we will compute the earned premium for that period and send notice to the first Named Insured. The due date for audit and retrospective premiums is the date shown as the due date on the bill. If the sum of the advance and audit premiums paid for the policy period is greater than the earned premium, we will return the excess to the first Named Insured.
- c. The first Named Insured must keep records of the information we need for premium computation, and send us copies at such times as we may request.

**6. Representations**

By accepting this policy, you agree:

- a. The statements in the Declarations are accurate and complete;
- b. Those statements are based upon representations you made to us; and
- c. We have issued this policy in reliance upon your representations.

The unintentional omission of, or unintentional error in, any information provided by you which we relied upon in issuing this policy will not prejudice your rights under this insurance. However, this provision does not affect our right to collect additional premium or to exercise our rights of cancellation or nonrenewal in accordance with applicable insurance laws or regulations.

**7. Separation Of Insureds**

Except with respect to the Limits of Insurance, and any rights or duties specifically assigned in this Coverage Part to the first Named Insured, this insurance applies:

- a. As if each Named Insured were the only Named Insured; and
- b. Separately to each insured against whom claim is made or "suit" is brought.

**8. Transfer Of Rights Of Recovery Against Others To Us**

If the insured has rights to recover all or part of any payment we have made under this Coverage Part, those rights are transferred to us. The insured must do nothing after loss to impair them. At our request, the insured will bring "suit" or transfer those rights to us and help us enforce them.

**9. When We Do Not Renew**

If we decide not to renew this Coverage Part, we will mail or deliver to the first Named Insured shown in the Declarations written notice of the nonrenewal not less than 30 days before the expiration date.

If notice is mailed, proof of mailing will be sufficient proof of notice.

**SECTION V — DEFINITIONS**

1. "Advertisement" means a notice that is broadcast or published to the general public or specific market segments about your goods, products or services for the purpose of attracting customers or supporters. For the purposes of this definition:

- a. Notices that are published include material placed on the Internet or on similar electronic means of communication; and
- b. Regarding websites, only that part of a website that is about your goods, products or services for the purposes of attracting customers or

**THIS ENDORSEMENT CHANGES THE POLICY. PLEASE READ IT CAREFULLY.**

## **XTEND ENDORSEMENT FOR MANUFACTURERS AND WHOLESALEERS**

This endorsement modifies insurance provided under the following:

### **COMMERCIAL GENERAL LIABILITY COVERAGE PART**

**GENERAL DESCRIPTION OF COVERAGE** – This endorsement broadens coverage. However, coverage for any injury, damage or medical expenses described in any of the provisions of this endorsement may be excluded or limited by another endorsement to this Coverage Part, and these coverage broadening provisions do not apply to the extent that coverage is excluded or limited by such an endorsement. The following listing is a general coverage description only. Read all the provisions of this endorsement and the rest of your policy carefully to determine rights, duties, and what is and is not covered.

- |  |  |
|--|--|
| <ul style="list-style-type: none"> <li><b>A.</b> Who Is An Insured – Unnamed Subsidiaries</li> <li><b>B.</b> Who Is An Insured – Employees And Volunteer Workers – Bodily Injury To Co-Employees And Co-Volunteer Workers</li> <li><b>C.</b> Who Is An Insured – Newly Acquired Or Formed Limited Liability Companies</li> <li><b>D.</b> Blanket Additional Insured – Broad Form Vendors</li> <li><b>E.</b> Blanket Additional Insured – Controlling Interest</li> <li><b>F.</b> Blanket Additional Insured – Mortgagees, Assignees, Successors Or Receivers</li> <li><b>G.</b> Blanket Additional Insured – Governmental Entities – Permits Or Authorizations Relating To Premises</li> </ul> | <ul style="list-style-type: none"> <li><b>H.</b> Blanket Additional Insured – Governmental Entities – Permits Or Authorizations Relating To Operations</li> <li><b>I.</b> Blanket Additional Insured – Grantors Of Franchises</li> <li><b>J.</b> Incidental Medical Malpractice</li> <li><b>K.</b> Medical Payments – Increased Limit</li> <li><b>L.</b> Blanket Waiver Of Subrogation</li> <li><b>M.</b> Contractual Liability – Railroads</li> </ul> |
|--|--|

### **PROVISIONS**

#### **A. WHO IS AN INSURED – UNNAMED SUBSIDIARIES**

The following is added to **SECTION II – WHO IS AN INSURED**:

Any of your subsidiaries, other than a partnership or joint venture, that is not shown as a Named Insured in the Declarations is a Named Insured if:

- a.** You are the sole owner of, or maintain an ownership interest of more than 50% in, such subsidiary on the first day of the policy period; and
- b.** Such subsidiary is not an insured under similar other insurance.

No such subsidiary is an insured for "bodily injury" or "property damage" that occurred, or "personal and advertising injury" caused by an offense committed:

- a.** Before you maintained an ownership interest of more than 50% in such subsidiary; or
- b.** After the date, if any, during the policy period that you no longer maintain an ownership interest of more than 50% in such subsidiary.

For purposes of Paragraph 1. of Section II – Who Is An Insured, each such subsidiary will be deemed to be designated in the Declarations as:

- a.** A limited liability company;
- b.** An organization other than a partnership, joint venture or limited liability company; or
- c.** A trust;

as indicated in its name or the documents that govern its structure.

**B. WHO IS AN INSURED – EMPLOYEES AND VOLUNTEER WORKERS – BODILY INJURY TO CO-EMPLOYEES AND CO-VOLUNTEER WORKERS**

The following is added to Paragraph 2.a.(1) of SECTION II – WHO IS AN INSURED:

Paragraphs (1)(a), (b) and (c) above do not apply to "bodily injury" to a co-"employee" while in the course of the co-"employee's" employment by you or performing duties related to the conduct of your business, or to "bodily injury" to your other "volunteer workers" while performing duties related to the conduct of your business.

**C. WHO IS AN INSURED – NEWLY ACQUIRED OR FORMED LIMITED LIABILITY COMPANIES**

The following replaces Paragraph 3. of SECTION II – WHO IS AN INSURED:

3. Any organization you newly acquire or form, other than a partnership or joint venture, and of which you are the sole owner or in which you maintain an ownership interest of more than 50%, will qualify as a Named Insured if there is no other similar insurance available to that organization. However:

- a. Coverage under this provision is afforded only:
  - (1) Until the 180th day after you acquire or form the organization or the end of the policy period, whichever is earlier, if you do not report such organization in writing to us within 180 days after you acquire or form it; or
  - (2) Until the end of the policy period, when that date is later than 180 days after you acquire or form such organization, if you report such organization in writing to us within 180 days after you acquire or form it;
- b. Coverage A does not apply to "bodily injury" or "property damage" that occurred before you acquired or formed the organization; and
- c. Coverage B does not apply to "personal and advertising injury" arising out of an offense committed before you acquired or formed the organization.

For the purposes of Paragraph 1. of Section II – Who Is An Insured, each such organization will be deemed to be designated in the Declarations as:

- a. A limited liability company;
  - b. An organization, other than a partnership, joint venture or limited liability company; or
  - c. A trust;
- as indicated in its name or the documents that govern its structure.

**D. BLANKET ADDITIONAL INSURED – BROAD FORM VENDORS**

The following is added to SECTION II – WHO IS AN INSURED:

Any person or organization that is a vendor and that you have agreed in a written contract or agreement to include as an additional insured on this Coverage Part is an insured, but only with respect to liability for "bodily injury" or "property damage" that:

- a. Occurs subsequent to the signing of that contract or agreement; and
- b. Arises out of "your products" that are distributed or sold in the regular course of such vendor's business.

The insurance provided to such vendor is subject to the following provisions:

- a. The limits of insurance provided to such vendor will be the minimum limits that you agreed to provide in the written contract or agreement, or the limits shown in the Declarations, whichever are less.
- b. The insurance provided to such vendor does not apply to:
  - (1) Any express warranty not authorized by you or any distribution or sale for a purpose not authorized by you;
  - (2) Any change in "your products" made by such vendor;
  - (3) Repackaging, unless unpacked solely for the purpose of inspection, demonstration, testing, or the substitution of parts under instructions from the manufacturer, and then repackaged in the original container;
  - (4) Any failure to make such inspections, adjustments, tests or servicing as vendors agree to perform or normally undertake to perform in the regular course of business, in connection with the distribution or sale of "your products";



- (5) Demonstration, installation, servicing or repair operations, except such operations performed at such vendor's premises in connection with the sale of "your products"; or
- (6) "Your products" that, after distribution or sale by you, have been labeled or relabeled or used as a container, part or ingredient of any other thing or substance by or on behalf of such vendor.

Coverage under this provision does not apply to:

- a. Any person or organization from whom you have acquired "your products", or any ingredient, part or container entering into, accompanying or containing such products; or
- b. Any vendor for which coverage as an additional insured specifically is scheduled by endorsement.

**E. BLANKET ADDITIONAL INSURED – CONTROLLING INTEREST**

- 1. The following is added to **SECTION II – WHO IS AN INSURED**:

Any person or organization that has financial control of you is an insured with respect to liability for "bodily injury", "property damage" or "personal and advertising injury" that arises out of:

- a. Such financial control; or
- b. Such person's or organization's ownership, maintenance or use of premises leased to or occupied by you.

The insurance provided to such person or organization does not apply to structural alterations, new construction or demolition operations performed by or on behalf of such person or organization.

- 2. The following is added to Paragraph 4. of **SECTION II – WHO IS AN INSURED**:

This paragraph does not apply to any premises owner, manager or lessor that has financial control of you.

**F. BLANKET ADDITIONAL INSURED – MORTGAGEES, ASSIGNEES, SUCCESSORS OR RECEIVERS**

The following is added to **SECTION II – WHO IS AN INSURED**:

Any person or organization that is a mortgagee, assignee, successor or receiver and that you have agreed in a written contract or agreement to include as an additional insured on this Coverage Part is an insured, but only with respect to its

liability as mortgagee, assignee, successor or receiver for "bodily injury", "property damage" or "personal and advertising injury" that:

- a. Is "bodily injury" or "property damage" that occurs, or is "personal and advertising injury" caused by an offense that is committed, subsequent to the signing of that contract or agreement; and
- b. Arises out of the ownership, maintenance or use of the premises for which that mortgagee, assignee, successor or receiver is required under that contract or agreement to be included as an additional insured on this Coverage Part.

The insurance provided to such mortgagee, assignee, successor or receiver is subject to the following provisions:

- a. The limits of insurance provided to such mortgagee, assignee, successor or receiver will be the minimum limits that you agreed to provide in the written contract or agreement, or the limits shown in the Declarations, whichever are less.
- b. The insurance provided to such person or organization does not apply to:
  - (1) Any "bodily injury" or "property damage" that occurs, or any "personal and advertising injury" caused by an offense that is committed, after such contract or agreement is no longer in effect; or
  - (2) Any "bodily injury", "property damage" or "personal and advertising injury" arising out of any structural alterations, new construction or demolition operations performed by or on behalf of such mortgagee, assignee, successor or receiver.

**G. BLANKET ADDITIONAL INSURED – GOVERNMENTAL ENTITIES – PERMITS OR AUTHORIZATIONS RELATING TO PREMISES**

The following is added to **SECTION II – WHO IS AN INSURED**:

Any governmental entity that has issued a permit or authorization with respect to premises owned or occupied by, or rented or loaned to, you and that you are required by any ordinance, law, building code or written contract or agreement to include as an additional insured on this Coverage Part is an insured, but only with respect to liability for "bodily injury", "property damage" or "personal and advertising injury" arising out of the existence, ownership, use, maintenance, repair, construction, erection or removal of any of the following for which that governmental entity has

## COMMERCIAL GENERAL LIABILITY

issued such permit or authorization: advertising signs, awnings, canopies, cellar entrances, coal holes, driveways, manholes, marquees, hoist away openings, sidewalk vaults, elevators, street banners or decorations.

### H. BLANKET ADDITIONAL INSURED – GOVERNMENTAL ENTITIES – PERMITS OR AUTHORIZATIONS RELATING TO OPERATIONS

The following is added to **SECTION II – WHO IS AN INSURED**:

Any governmental entity that has issued a permit or authorization with respect to operations performed by you or on your behalf and that you are required by any ordinance, law, building code or written contract or agreement to include as an additional insured on this Coverage Part is an insured, but only with respect to liability for "bodily injury", "property damage" or "personal and advertising injury" arising out of such operations.

The insurance provided to such governmental entity does not apply to:

- a. Any "bodily injury", "property damage" or "personal and advertising injury" arising out of operations performed for the governmental entity; or
- b. Any "bodily injury" or "property damage" included in the "products-completed operations hazard".

### I. BLANKET ADDITIONAL INSURED – GRANTORS OF FRANCHISES

The following is added to **SECTION II – WHO IS AN INSURED**:

Any person or organization that grants a franchise to you is an insured, but only with respect to liability for "bodily injury", "property damage" or "personal and advertising injury" arising out of your operations in the franchise granted by that person or organization.

If a written contract or agreement exists between you and such additional insured, the limits of insurance provided to such insured will be the minimum limits that you agreed to provide in the written contract or agreement, or the limits shown in the Declarations, whichever are less.

### J. INCIDENTAL MEDICAL MALPRACTICE

1. The following replaces Paragraph **b.** of the definition of "occurrence" in the **DEFINITIONS** Section:

- b. An act or omission committed in providing or failing to provide "incidental medical

services", first aid or "Good Samaritan services" to a person, unless you are in the business or occupation of providing professional health care services.

2. The following replaces the last paragraph of Paragraph **2.a.(1)** of **SECTION II – WHO IS AN INSURED**:

Unless you are in the business or occupation of providing professional health care services, Paragraphs **(1)(a)**, **(b)**, **(c)** and **(d)** above do not apply to "bodily injury" arising out of providing or failing to provide:

- (a) "Incidental medical services" by any of your "employees" who is a nurse, nurse assistant, emergency medical technician, paramedic, athletic trainer, audiologist, dietician, nutritionist, occupational therapist or occupational therapy assistant, physical therapist or speech-language pathologist; or
- (b) First aid or "Good Samaritan services" by any of your "employees" or "volunteer workers", other than an employed or volunteer doctor. Any such "employees" or "volunteer workers" providing or failing to provide first aid or "Good Samaritan services" during their work hours for you will be deemed to be acting within the scope of their employment by you or performing duties related to the conduct of your business.

3. The following replaces the last sentence of Paragraph **5.** of **SECTION III – LIMITS OF INSURANCE**:

For the purposes of determining the applicable Each Occurrence Limit, all related acts or omissions committed in providing or failing to provide "incidental medical services", first aid or "Good Samaritan services" to any one person will be deemed to be one "occurrence".

4. The following exclusion is added to Paragraph **2.**, **Exclusions**, of **SECTION I – COVERAGES – COVERAGE A – BODILY INJURY AND PROPERTY DAMAGE LIABILITY**:

#### Sale Of Pharmaceuticals

"Bodily injury" or "property damage" arising out of the violation of a penal statute or ordinance relating to the sale of pharmaceuticals committed by, or with the knowledge or consent of, the insured.

5. The following is added to the **DEFINITIONS** Section:

"Incidental medical services" means:

- a. Medical, surgical, dental, laboratory, x-ray or nursing service or treatment, advice or instruction, or the related furnishing of food or beverages; or
- b. The furnishing or dispensing of drugs or medical, dental, or surgical supplies or appliances.

6. The following is added to Paragraph **4.b.**, **Excess Insurance**, of **SECTION IV – COMMERCIAL GENERAL LIABILITY CONDITIONS**:

This insurance is excess over any valid and collectible other insurance, whether primary, excess, contingent or on any other basis, that is available to any of your "employees" for "bodily injury" that arises out of providing or failing to provide "incidental medical services" to any person to the extent not subject to Paragraph **2.a.(1)** of Section **II – Who Is An Insured**.

**K. MEDICAL PAYMENTS – INCREASED LIMIT**

The following replaces Paragraph **7.** of **SECTION III – LIMITS OF INSURANCE**:

7. Subject to Paragraph **5.** above, the Medical Expense Limit is the most we will pay under Coverage **C** for all medical expenses because of "bodily injury" sustained by any one person, and will be the higher of:

- a. \$10,000; or
- b. The amount shown in the Declarations of this Coverage Part for Medical Expense Limit.

**L. BLANKET WAIVER OF SUBROGATION**

The following is added to Paragraph **8.**, **Transfer Of Rights Of Recovery Against Others To Us**, of **SECTION IV – COMMERCIAL GENERAL LIABILITY CONDITIONS**:

If the insured has agreed in a contract or agreement to waive that insured's right of recovery against any person or organization, we waive our right of recovery against such person or organization, but only for payments we make because of:

- a. "Bodily injury" or "property damage" that occurs; or
- b. "Personal and advertising injury" caused by an offense that is committed; subsequent to the execution of the contract or agreement.

**M. CONTRACTUAL LIABILITY – RAILROADS**

- 1. The following replaces Paragraph **c.** of the definition of "insured contract" in the **DEFINITIONS** Section:
  - c. Any easement or license agreement;
- 2. Paragraph **f.(1)** of the definition of "insured contract" in the **DEFINITIONS** Section is deleted.



**Agenda Sheet for City Council:**

**Committee:** PIES **Date:** 10/21/2024

**Committee Agenda type:** Consent

**Date Rec'd** 10/22/2024

**Clerk's File #** OPR 2024-0935

**Cross Ref #**

**Project #**

**Council Meeting Date:** 11/04/2024

<b>Submitting Dept</b>	STREETS	<b>Bid #</b>	
------------------------	---------	--------------	--

<b>Contact Name/Phone</b>	CLINT HARRIS 625-7744	<b>Requisition #</b>	
---------------------------	-----------------------	----------------------	--

<b>Contact E-Mail</b>	CEHARRIS@SPOKANECITY.ORG		
-----------------------	--------------------------	--	--

<b>Agenda Item Type</b>	Purchase w/o Contract		
-------------------------	-----------------------	--	--

<b>Council Sponsor(s)</b>	BWILKERSON JBINGLE KKLITZKE		
---------------------------	-----------------------------	--	--

<b>Agenda Item Name</b>	1100 - STREETS ROAD SALT		
-------------------------	--------------------------	--	--

**Agenda Wording**

The Street Department is seeking approval for the purchase of Road Salt at a cost not to exceed \$140,000.00.

**Summary (Background)**

This material is used by the Streets Department during the winter months to aid in snow and ice removal. It is primarily mixed with sand and used on sanding routes. The material is purchased off the State Contract #11021. Road Salt is purchased from Salt Distributors Inc.

Lease? NO Grant related? NO Public Works? NO

**Fiscal Impact**

Approved in Current Year Budget? YES

Total Cost \$ 140,000

Current Year Cost \$

Subsequent Year(s) Cost \$

**Narrative**

**Amount**

**Budget Account**

Expense	\$ 140,000	# 1100-21800-42660-53210-99999
Select	\$	#
Select	\$	#
Select	\$	#
	\$	#
	\$	#



## Continuation of Wording, Summary, Approvals, and Distribution

### Agenda Wording

### Summary (Background)

#### **Approvals**

##### Dept Head

HARRIS, CLINT E.

##### Division Director

FEIST, MARLENE

##### Accounting Manager

ORLOB, KIMBERLY

##### Legal

HARRINGTON,

##### For the Mayor

PICCOLO, MIKE

#### **Additional Approvals**

#### **Distribution List**

CEHARRIS@SPOKANECITY.ORG

JWTHOMAS@SPOKANECITY.ORG

KAIUMU@SPOKANECITY.ORG

## Committee Briefing Paper

### Public Infrastructure, Environment & Sustainability Committee

<b>Committee Date</b>	10/21/2024
<b>Submitting Department</b>	Streets
<b>Contact Name</b>	Clint Harris
<b>Contact Email &amp; Phone</b>	<a href="mailto:ceharris@spokanecity.org">ceharris@spokanecity.org</a> 625-7744
<b>Council Sponsor(s)</b>	Wilkerson, Bingle, Klitzke
<b>Select Agenda Item Type</b>	<input checked="" type="checkbox"/> Consent <input type="checkbox"/> Discussion    Time Requested:
<b>Agenda Item Name</b>	1100 – Streets Road Salt
<b>Proposed Council Action</b>	<input checked="" type="checkbox"/> Approval to proceed to Legislative Agenda <input type="checkbox"/> Information Only
<b>Summary (Background)</b>	<p>The Street Department is seeking approval for the purchase of Road Salt at a cost not to exceed \$140,000.00.</p> <p>This material is used by the Streets Department during the winter months to aid in snow and ice removal. It is primarily mixed with sand and used on sanding routes. The material is purchased off the State Contract #11021. Ice Kicker is purchased from Salt Distributors Inc.</p>
<b>Summary (Background)</b>	<p>*use the Fiscal Impact box below for relevant financial information</p>
<p><b>Fiscal Impact</b></p> <p><b>Approved in current year budget?</b>    <input checked="" type="checkbox"/> Yes    <input type="checkbox"/> No    <input type="checkbox"/> N/A</p> <p>Total Cost: <u>140,000.00</u></p> <p>Current year cost:</p> <p>Subsequent year(s) cost:</p> <p><b>Narrative:</b> Please provide financial due diligence review, as applicable, such as number and type of positions, grant match requirements, summary type details (personnel, maintenance and supplies, capital, revenue), impact on rates, fees, or future shared revenue</p> <p><b>Funding Source</b>    <input type="checkbox"/> One-time    <input checked="" type="checkbox"/> Recurring    <input type="checkbox"/> N/A</p> <p>Specify funding source: Select Funding Source*</p> <p>Is this funding source sustainable for future years, months, etc? <a href="#">Click or tap here to enter text.</a></p> <p><b>Expense Occurrence</b>    <input type="checkbox"/> One-time    <input checked="" type="checkbox"/> Recurring    <input type="checkbox"/> N/A</p> <p>Other budget impacts: (revenue generating, match requirements, etc.)</p>	
<p><b>Operations Impacts</b> (If N/A, please give a brief description as to why)</p> <ul style="list-style-type: none"> <li>• What impacts would the proposal have on historically excluded communities? <u>N/A, material will be used to maintain roadways across the city.</u></li> <li>• How will data be collected, analyzed, and reported concerning the effect of the program/policy by racial, ethnic, gender identity, national origin, income level, disability, sexual orientation, or other existing disparities? <u>N/A, material will be used to maintain roadways across the city.</u></li> </ul>	

- How will data be collected regarding the effectiveness of this program, policy, or product to ensure it is the right solution?

N/A, material will be used to maintain roadways across the city.

- Describe how this proposal aligns with current City Policies, including the Comprehensive Plan, Sustainability Action Plan, Capital Improvement Program, Neighborhood Master Plans, Council Resolutions, and others?

N/A, material will be used to maintain roadways across the city.

### **Council Subcommittee Review**

- Please provide a summary of council subcommittee review. If not reviewed by a council subcommittee, please explain why not.

Subcommittee review not necessary.

State of Washington Contracts & Procurement Division Department of Enterprise Services P.O. Box 41411 Olympia, WA 98504-1411	<b>CONTRACT AMENDMENT</b>	
	Contract No.:	11021
Salt Distributors, INC 15201 E. Marietta Ave Spokane Valley, WA 99216	Amendment No.:	5
	Effective Date:	07-01-2024

**FIFTH AMENDMENT**  
**TO**  
**CONTRACT NO. 11021**  
**SNOW & ICE CONTROL PRODUCTS**

This Fifth Amendment (“Amendment”) to Contract No. 11021 is made and entered into by and between the State of Washington acting by and through the Department of Enterprise Services, a Washington State governmental agency (“Enterprise Services”) and Salt Distributors, Inc, a Washington Corporation (“Contractor”) and is dated and effective as of July 1, 2024.

**RECITALS**

- A. Enterprise Services and Contractor (collectively the “Parties”) entered into that certain Contract No. 11021 dated effective as of August 1, 2022 (“Contract”).
- B. The Parties previously amended the Contract as follows:
  - i. Amendment 1 effective October 3, 2022 (establishing 80/120 commitments for 2022-2023 winter season);
  - ii. Amendment 2 effective October 1, 2023 (economic price adjustment);
  - iii. Amendment 3 effective October 15, 2023 (establishing 80/120 commitments for 2023-2024 winter season);
  - iv. Amendment 4 effective April 15, 2024 (update economic price adjustment and insurance requirements provisions, update the 80/120 Annual Purchase Volume Commitment form and provision, and add Nondiscrimination provision).
- C. The amendment set forth herein is within the scope of the Contract.
- D. The Parties now desire to amend the Contract as follows:
  - i. Perform an annual economic price adjustment;
  - ii. Extend the term of the Contract forty-eight (48) months;
  - iii. Revise the sales reporting requirements;
  - iv. Update the QPL hyperlink.



## AGREEMENT

**NOW THEREFORE**, in consideration of the mutual covenants and agreements set forth herein, the Parties hereby agree to amend the Contract, as previously amended, as follows:

1. **TERM.** In accordance with provision 1. "Term," the Term is extended for forty-eight (48) months, ending August 1, 2028.
2. **ECONOMIC ADJUSTMENT.** Pursuant to section 3.3 of the Contract, the pricing for the goods is hereby amended by deleting the existing *Exhibit B – Prices for Goods* (dated April 1, 2024) in its entirety and inserting the attached *Exhibit B – Prices for Goods* (dated July 1, 2024). These prices include the agreed economic adjustment from Bureau of Labor and Statistics (BLS) index/indices: PPI series WPU6130271; PPI series PCU32518032518P; PPI series PCU482---482; and PPI series PCU484---484. Price adjustments are based on individual contractor weighted adjustments. There are multiple final negotiated weighted adjustments for the categories.
3. **ANNUAL MASTER CONTRACT SALES REPORT.** Section 12.3 of the Contract (Annual Master Contract Sale) is hereby amended by deleting the existing Section 12.3 in its entirety and inserting the following in lieu thereof:

12.3. **ANNUAL CONTRACT SALES REPORT.** Contractor shall provide to Enterprise Services a detailed Annual Contract Sales Report. Such Report shall include, at a minimum, the following:

- DES Contract #11021
- The product purchased (including, as applicable, item number or other identifier)
- Purchaser's Delivery Region, Maintenance Area, Specific location
- Date Ordered
- Delivery Option (3 Day, 7 Day, 30 Day delivery)
- Items and volumes purchased by Purchaser
- Date Delivered to Purchaser's location
- Invoice/Contract price
- Annual total volume sales

This Report must be provided in an electronic format that can be read by Microsoft (MS) Excel. Such Report is due within thirty (30) calendar days of the annual anniversary of the effective date of this Contract.

4. **MONTHLY CONTRACT ACTIVITY REPORTS.** Section 12.4 of the Contract (Monthly Contract Activity Reports) is hereby by deleted in its entirety.
5. The embedded hyper link to the Clear Roads Qualified Products List (QPL) is not working, accordingly, to provide the correct hyperlink, Section 1, Section 4.19, and Exhibit A is amended by deleting the existing hyper link in its entirety and replacing it with the following (to provide the correct hyperlink): new hyperlink <https://www.clearroads.org/qualified-product-list/> for the latest Clear Roads Qualified Products List (QPL).

6. NO CHANGE OTHER THAN AMENDMENT. Except as amended herein, the Contract is unaffected and remains in full force and effect.
7. INTEGRATED AGREEMENT; MODIFICATION. This Amendment constitutes the entire agreement and understanding of the Parties with respect to the subject matter and supersedes all prior negotiations and representations. In the event of any conflict between this Amendment and the Contract or any earlier amendment, this Amendment shall control and govern. This Amendment may not be modified except in writing signed by the Parties.
8. AUTHORITY. Each party to this Amendment, and each individual signing on behalf of each party, hereby represents and warrants to the other that it has full power and authority to enter into this Amendment and that its execution, delivery, and performance of this Amendment has been fully authorized and approved, and that no further approvals or consents are required to bind such party.
9. ELECTRONIC SIGNATURES. An electronic signature or electronic record of this Amendment or any other ancillary agreement shall be deemed to have the same legal effect as delivery of an original executed copy of this Amendment or such other ancillary agreement for all purposes.
10. COUNTERPARTS. This Amendment may be executed in one or more counterparts, each of which shall be deemed an original, and all of which counterparts together shall constitute the same instrument which may be sufficiently evidenced by one counterpart. Execution of this Amendment at different times and places by the parties shall not affect the validity thereof so long as all the parties hereto execute a counterpart of this Amendment.

EXECUTED AND EFFECTIVE as of the day and date first above written.

**Salt Distributors, Inc.**

**A Washington Corporation**

By:   
 Name: Nic Binczewski  
 Title: VP  
 Date: 6-27-24

**State of Washington**

**Department of Enterprise Services**

By: Theresa Jensen Digitally signed by Theresa Jensen  
Date: 2024.06.27 16:15:25 -07'00'  
 Name: Theresa Jensen  
 Title: Procurement Supervisor  
 Date: June 27, 2024

PRICES FOR GOODS  
DATED JULY 1, 2024

**Category 4C**  
**Corrosion Inhibited Solid Sodium Chloride - Grade 2, Maximum Moisture Content**  
**5% Standard Gradation**

Anti-Caking Agent:	Proprietary Blend of Additives
Product:	Ice Kicker
Drop Shipment:	\$75

**WSDOT Region 1 Northwest**

Order/Delivery Area	3 Days	7 Days	30 Days
Maintenance Area 1	\$228.72	\$221.29	\$215.99
Maintenance Area 2	\$229.98	\$222.56	\$217.25
Maintenance Area 3	\$226.91	\$219.49	\$214.19
Maintenance Area 4	\$208.53	\$201.10	\$195.80
Maintenance Area 5	\$214.66	\$207.23	\$201.93

**WSDOT Region 2 North Central**

Order/Delivery Area	3 Days	7 Days	30 Days
Maintenance Area 1	\$202.36	\$194.95	\$189.66
Maintenance Area 2	\$187.37	\$179.96	\$174.66
Maintenance Area 3	\$207.46	\$200.05	\$194.75

**WSDOT Region 3 Olympic**

Order/Delivery Area	3 Days	7 Days	30 Days
Maintenance Area 1	\$203.81	\$196.39	\$191.09
Maintenance Area 2	\$212.53	\$205.11	\$198.75
Maintenance Area 3	\$226.79	\$219.37	\$214.07
Maintenance Area 4	\$212.66	\$205.24	\$199.94

**WSDOT Region 4 Southwest**

Order/Delivery Area	3 Days	7 Days	30 Days
Maintenance Area 1	\$229.83	\$222.41	\$211.11
Maintenance Area 2	\$207.89	\$200.47	\$201.92
Maintenance Area 3	\$223.70	\$216.28	\$204.99
Maintenance Area 4	\$212.66	\$205.24	\$193.94

**WSDOT Region 5 South Central**

Order/Delivery Area	3 Days	7 Days	30 Days
Maintenance Area 1	\$211.44	\$204.02	\$192.73
Maintenance Area 2	\$207.89	\$200.47	\$189.18
Maintenance Area 3	\$190.61	\$183.19	\$171.89
Maintenance Area 4	\$193.95	\$186.53	\$175.23

**WSDOT Region 6 Eastern**

Order/Delivery Area	3 Days	7 Days	30 Days
Maintenance Area 1	\$185.12	\$177.71	\$172.41
Maintenance Area 2	\$185.82	\$178.41	\$173.11
Maintenance Area 3	\$186.47	\$179.05	\$173.76
Maintenance Area 4	\$192.49	\$185.08	\$179.78

**Category 8A-B  
Standard Gradation Brining Salt**

Anti-Caking Agent:	None
Product:	Drirox Extra Coarse
Drop Shipment:	\$75

**WSDOT Region 1 Northwest**

Order/Delivery Area	3 Days	7 Days	30 Days
Maintenance Area 1	\$232.39	\$225.01	\$219.74
Maintenance Area 2	\$239.78	\$232.39	\$225.01
Maintenance Area 3	\$236.59	\$229.21	\$223.93
Maintenance Area 4	\$218.30	\$210.92	\$205.64
Maintenance Area 5	\$224.40	\$217.01	\$211.74

**WSDOT Region 2 North Central**

Order/Delivery Area	3 Days	7 Days	30 Days
Maintenance Area 1	\$211.03	\$203.66	\$198.40
Maintenance Area 2	\$196.12	\$188.75	\$183.49
Maintenance Area 3	\$216.10	\$208.73	\$203.46

**WSDOT Region 3 Olympic**

Order/Delivery Area	3 Days	7 Days	30 Days
Maintenance Area 1	\$213.46	\$206.08	\$200.82
Maintenance Area 2	\$222.13	\$214.76	\$208.43
Maintenance Area 3	\$236.30	\$228.93	\$223.66
Maintenance Area 4	\$230.21	\$222.84	\$205.82

**WSDOT Region 4 Southwest**

Order/Delivery Area	3 Days	7 Days	30 Days
Maintenance Area 1	\$239.39	\$232.02	\$226.75
Maintenance Area 2	\$228.15	\$220.77	\$217.61
Maintenance Area 3	\$233.30	\$225.92	\$220.66
Maintenance Area 4	\$218.46	\$211.09	\$205.82

**WSDOT Region 5 South Central**

Order/Delivery Area	3 Days	7 Days	30 Days
Maintenance Area 1	\$216.13	\$208.76	\$206.65
Maintenance Area 2	\$211.09	\$203.71	\$198.44
Maintenance Area 3	\$211.61	\$204.24	\$198.97
Maintenance Area 4	\$198.74	\$191.36	\$189.25

**WSDOT Region 6 Eastern**

Order/Delivery Area	3 Days	7 Days	30 Days
Maintenance Area 1	\$187.83	\$180.46	\$175.20
Maintenance Area 2	\$188.52	\$181.16	\$175.89
Maintenance Area 3	\$189.17	\$181.80	\$176.53
Maintenance Area 4	\$195.16	\$187.79	\$182.52

**Category 8A-R  
Standard Gradation Road Salt**

Anti-Caking Agent:	none
Product:	Drinox Extra Coarse
Drop Shipment:	\$75

**WSDOT Region 1 Northwest**

Order/Delivery Area	3 Days	7 Days	30 Days
Maintenance Area 1	\$232.39	\$225.01	\$219.74
Maintenance Area 2	\$239.78	\$232.39	\$225.01
Maintenance Area 3	\$236.59	\$229.21	\$223.93
Maintenance Area 4	\$218.30	\$210.92	\$205.64
Maintenance Area 5	\$224.40	\$217.01	\$211.74

**WSDOT Region 2 North Central**

Order/Delivery Area	3 Days	7 Days	30 Days
Maintenance Area 1	\$211.03	\$203.66	\$198.40
Maintenance Area 2	\$196.12	\$188.75	\$183.49
Maintenance Area 3	\$216.10	\$208.73	\$203.46

**WSDOT Region 3 Olympic**

Order/Delivery Area	3 Days	7 Days	30 Days
Maintenance Area 1	\$213.46	\$206.08	\$200.82
Maintenance Area 2	\$222.13	\$214.76	\$208.43
Maintenance Area 3	\$236.30	\$228.93	\$223.66
Maintenance Area 4	\$230.21	\$222.84	\$217.57

**WSDOT Region 4 Southwest**

Order/Delivery Area	3 Days	7 Days	30 Days
Maintenance Area 1	\$239.39	\$232.02	\$226.75
Maintenance Area 2	\$228.15	\$220.77	\$217.61
Maintenance Area 3	\$233.30	\$225.92	\$220.66
Maintenance Area 4	\$218.46	\$211.09	\$205.82

**WSDOT Region 5 South Central**

Order/Delivery Area	3 Days	7 Days	30 Days
Maintenance Area 1	\$216.18	\$208.80	\$206.69
Maintenance Area 2	\$211.13	\$203.75	\$198.48
Maintenance Area 3	\$211.65	\$204.28	\$199.01
Maintenance Area 4	\$198.77	\$191.40	\$189.29

**WSDOT Region 6 Eastern**

Order/Delivery Area	3 Days	7 Days	30 Days
Maintenance Area 1	\$187.83	\$180.46	\$175.20
Maintenance Area 2	\$188.52	\$181.16	\$175.89
Maintenance Area 3	\$187.17	\$181.80	\$176.53
Maintenance Area 4	\$195.16	\$187.79	\$182.52

**Category 8B  
Solid Sodium Chloride**

Anti-Caking Agent:	YPS
Product:	Qwiksalt
Drop Shipment:	\$75

**WSDOT Region 1 Northwest**

Order/Delivery Area	3 Days	7 Days	30 Days
Maintenance Area 1	\$201.40	\$193.99	\$188.70
Maintenance Area 2	\$206.69	\$199.28	\$193.99
Maintenance Area 3	\$199.60	\$192.19	\$186.90
Maintenance Area 4	\$182.30	\$174.89	\$168.54
Maintenance Area 5	\$187.36	\$179.95	\$174.66

**WSDOT Region 2 North Central**

Order/Delivery Area	3 Days	7 Days	30 Days
Maintenance Area 1	\$173.53	\$166.13	\$160.85
Maintenance Area 2	\$163.85	\$156.45	\$151.16
Maintenance Area 3	\$178.62	\$171.22	\$165.93

**WSDOT Region 3 Olympic**

Order/Delivery Area	3 Days	7 Days	30 Days
Maintenance Area 1	\$176.52	\$166.11	\$163.82
Maintenance Area 2	\$184.16	\$176.76	\$171.47
Maintenance Area 3	\$199.45	\$192.04	\$186.75
Maintenance Area 4	\$193.33	\$185.93	\$180.64

**WSDOT Region 4 Southwest**

Order/Delivery Area	3 Days	7 Days	30 Days
Maintenance Area 1	\$202.47	\$195.06	\$183.78
Maintenance Area 2	\$193.30	\$185.89	\$174.61
Maintenance Area 3	\$196.35	\$188.95	\$177.66
Maintenance Area 4	\$189.06	\$181.65	\$170.37

**WSDOT Region 5 South Central**

Order/Delivery Area	3 Days	7 Days	30 Days
Maintenance Area 1	\$181.73	\$174.33	\$163.04
Maintenance Area 2	\$182.94	\$175.54	\$162.13
Maintenance Area 3	\$173.21	\$165.81	\$154.52
Maintenance Area 4	\$174.85	\$167.44	\$156.16

**WSDOT Region 6 Eastern**

Order/Delivery Area	3 Days	7 Days	30 Days
Maintenance Area 1	\$157.79	\$150.39	\$137.58
Maintenance Area 2	\$153.20	\$145.80	\$137.33
Maintenance Area 3	\$155.96	\$148.56	\$136.92
Maintenance Area 4	\$162.42	\$155.01	\$150.78

**Category 8C-R  
Fine Gradation Road Salt**

Anti-Caking Agent:	None
Product:	Medium Solar Salt
Drop Shipment:	\$75

**WSDOT Region 1 Northwest**

Order/Delivery Area	3 Days	7 Days	30 Days
Maintenance Area 1	\$220.30	\$213.30	\$208.30
Maintenance Area 2	\$227.30	\$220.30	\$213.30
Maintenance Area 3	\$224.28	\$217.28	\$212.28
Maintenance Area 4	\$206.94	\$199.94	\$194.94
Maintenance Area 5	\$212.72	\$205.72	\$200.72

**WSDOT Region 2 North Central**

Order/Delivery Area	3 Days	7 Days	30 Days
Maintenance Area 1	\$200.41	\$193.41	\$188.41
Maintenance Area 2	\$186.25	\$179.25	\$174.25
Maintenance Area 3	\$205.22	\$198.22	\$193.22

**WSDOT Region 3 Olympic**

Order/Delivery Area	3 Days	7 Days	30 Days
Maintenance Area 1	\$202.60	\$195.60	\$190.60
Maintenance Area 2	\$210.83	\$203.83	\$197.83
Maintenance Area 3	\$224.28	\$217.28	\$212.28
Maintenance Area 4	\$218.50	\$211.50	\$206.50

**WSDOT Region 4 Southwest**

Order/Delivery Area	3 Days	7 Days	30 Days
Maintenance Area 1	\$227.17	\$220.17	\$215.17
Maintenance Area 2	\$216.50	\$209.50	\$206.50
Maintenance Area 3	\$221.39	\$214.39	\$209.39
Maintenance Area 4	\$207.31	\$200.31	\$195.31

**WSDOT Region 5 South Central**

Order/Delivery Area	3 Days	7 Days	30 Days
Maintenance Area 1	\$205.10	\$198.10	\$196.10
Maintenance Area 2	\$200.31	\$193.31	\$188.31
Maintenance Area 3	\$200.81	\$193.81	\$188.81
Maintenance Area 4	\$188.59	\$181.59	\$179.59



**WSDOT Region 6 Eastern**

Order/Delivery Area	3 Days	7 Days	30 Days
Maintenance Area 1	\$178.41	\$171.41	\$166.41
Maintenance Area 2	\$179.07	\$172.07	\$167.07
Maintenance Area 3	\$179.68	\$172.68	\$167.68
Maintenance Area 4	\$185.37	\$178.37	\$173.37

**Category 8C-B**

**Fine Gradation Brining Salt**

Anti-Caking Agent:	None
Product:	Medium Solar Salt
Drop Shipment:	\$75

**WSDOT Region 1 Northwest**

Order/Delivery Area	3 Days	7 Days	30 Days
Maintenance Area 1	\$220.30	\$213.30	\$208.30
Maintenance Area 2	\$227.30	\$220.30	\$213.30
Maintenance Area 3	\$224.28	\$217.28	\$212.28
Maintenance Area 4	\$206.94	\$199.94	\$194.94
Maintenance Area 5	\$212.72	\$205.72	\$200.72

**WSDOT Region 2 North Central**

Order/Delivery Area	3 Days	7 Days	30 Days
Maintenance Area 1	\$200.41	\$193.41	\$188.41
Maintenance Area 2	\$186.25	\$179.25	\$174.25
Maintenance Area 3	\$205.22	\$198.22	\$193.22

**WSDOT Region 3 Olympic**

Order/Delivery Area	3 Days	7 Days	30 Days
Maintenance Area 1	\$202.60	\$195.60	\$190.60
Maintenance Area 2	\$210.83	\$203.83	\$197.83
Maintenance Area 3	\$224.28	\$217.28	\$212.28
Maintenance Area 4	\$218.50	\$211.50	\$206.50

**WSDOT Region 4 Southwest**

Order/Delivery Area	3 Days	7 Days	30 Days
Maintenance Area 1	\$227.17	\$220.17	\$215.17
Maintenance Area 2	\$216.50	\$209.50	\$206.50
Maintenance Area 3	\$221.39	\$214.39	\$209.39
Maintenance Area 4	\$207.31	\$200.31	\$195.31

**WSDOT Region 5 South Central**

<b>Order/Delivery Area</b>	<b>3 Days</b>	<b>7 Days</b>	<b>30 Days</b>
Maintenance Area 1	\$205.10	\$198.10	\$196.10
Maintenance Area 2	\$200.31	\$193.31	\$188.31
Maintenance Area 3	\$200.81	\$193.81	\$188.81
Maintenance Area 4	\$188.59	\$181.59	\$179.59

**WSDOT Region 6 Eastern**

<b>Order/Delivery Area</b>	<b>3 Days</b>	<b>7 Days</b>	<b>30 Days</b>
Maintenance Area 1	\$178.41	\$171.41	\$166.41
Maintenance Area 2	\$179.07	\$172.07	\$167.07
Maintenance Area 3	\$179.68	\$172.68	\$167.68
Maintenance Area 4	\$185.37	\$178.37	\$173.37

State of Washington Contracts & Procurement Division Department of Enterprise Services P.O. Box 41411 Olympia, WA 98504-1411	<b>CONTRACT AMENDMENT</b>	
	Contract No.:	11021
Salt Distributors, INC 15201 E. Marietta Ave Spokane Valley, WA 99216	Amendment No.:	4
	Effective Date:	04-15-2024

**FOURTH AMENDMENT**  
**TO**  
**CONTRACT NO. 11021**  
**SNOW & ICE CONTROL PRODUCTS**

This Fourth Amendment (“Amendment”) to Contract No. 11021 is made and entered into by and between the State of Washington acting by and through the Department of Enterprise Services, a Washington State governmental agency (“Enterprise Services”) and Salt Distributors, Inc, a Washington Corporation (“Contractor”) and is dated and effective as of April 15, 2024.

**RECITALS**

- A. Enterprise Services and Contractor (collectively the “Parties”) entered into that certain Contract No. 11021 dated effective as of August 1, 2022 (“Contract”).
- B. The Parties previously amended the Contract as follows:
  - i. Amendment 1 effective October 3, 2022 (establishing 80/120 commitments for 2022-2023 winter season);
  - ii. Amendment 2 effective October 1, 2023 (economic price adjustment);
  - iii. Amendment 3 effective October 15, 2023 (establishing 80/120 commitments for 2023-2024 winter season);
- C. The parties now desire to amend the Contract to revise the Economic Adjustment requirements, the 80/120 Annual Purchase Volume Commitment provision (and provide for and attach an 80/120 Annual Purchase Volume Commitment Form for Purchasers to utilize at their discretion), and the Insurance Requirements, and to add a new Nondiscrimination provision required by Washington state law.
- D. The amendment set forth herein is within the scope of the Contract.
- E. The Parties now desire to amend the Contract as set forth herein.

**AGREEMENT**

**NOW THEREFORE**, in consideration of the mutual covenants and agreements set forth herein, the Parties hereby agree to amend the Contract, as previously amended, as follows:

1. ECONOMIC ADJUSTMENT. Section 3.3 of the Contract, titled Economic Adjustment is hereby amended by deleting such provisions in their entirety and inserting the following in lieu thereof:

ECONOMIC PRICE ADJUSTMENT. Prices as set forth in *Exhibit B – Prices for Goods*, may be adjusted as set forth herein.

- (a) Price Adjustment for PPI Changes. Beginning April 1, 2024, and annually thereafter, Contractor may request an economic price adjustment (EPA) to prices incorporated by reference as set forth in *Exhibit B – Prices For Goods*. Requests for EPA must be requested in writing and emailed to the Enterprise Service’s Contract Administrator and received by Enterprise Services between April 1st and April 30th of each year. Contractor’s EPA request cannot exceed the annual average percentage changes in the United States Department of Labor, Bureau of Labor and Statistics (BLS) Producer Price Indices (PPI) as set forth in the formula below. Once Contractor’s timely EPA request is received, Enterprise Services will analyze the PPI data to determine the appropriate EPA. Contract prices, as adjusted by an EPA shall be effective thereafter, beginning July 1st; *Provided*, however, that the parties must timely execute a contract amendment to incorporate such price adjustments. If Contractor does not timely submit an EPA request to Enterprise Services, there shall be no EPA allowed on the Contract for that the applicable period, and the following year the EPA shall not be retroactive nor cumulative to account for unrequested EPAs. Enterprise Services shall have the right to review PPI data annually and, if such PPI data reflects a substantial decrease in the annual average PPI, the parties shall amend the Contract to decrease the Contract prices accordingly.

The economic price adjustment shall be calculated as follows:

$$\text{New Price} = \text{Old Price} + (\text{Old Price} \times ((\text{Current Period Index} - \text{Base Period Index}) / \text{Base Period Index}))$$

The “Current Period Index” is the average of the most recent twelve months of BLS Index values, and the “Base Period Index” is the average of the twelve months of BLS Index values prior to the Current Period Index.

PPI values, including those that are preliminary at the time of the request, will be utilized in the analysis.

CATEGORY	PPI NAME	PPI CODE	CATEGORY 8B STANDARD GRADATION ROAD SALT, INSOLUBLE MATERIAL PERCENTAGE
Rock Salt	PPI Commodity data for Chemicals and allied products-Rock salt, not seasonally adjusted	WPU06130271	Eastern: 21% North Central: 18% South Central: 17% Southwest:16% Olympic: 17% Northwest: 15%

CATEGORY	PPI NAME	PPI CODE	CATEGORY 8B STANDARD GRADATION ROAD SALT, INSOLUBLE MATERIAL PERCENTAGE
Rail Transportation	PPI industry sub-sector data for Rail transportation, not seasonally adjusted	PCU482---482---	Eastern: 54% North Central: 45% South Central: 46% Southwest: 44% Olympic: 47% Northwest: 50%
Truck Transportation	PPI industry sub-sector data for Truck transportation, not seasonally adjusted	PCU484---484---	Eastern: 25% North Central: 37% South Central: 37% Southwest: 40% Olympic: 36% Northwest: 35%

CATEGORY	PPI NAME	PPI CODE	CATEGORY 4C CORROSION INHIBITED SOLID SODIUM CHLORIDE GRADE 2 PERCENTAGE
Rock Salt	PPI Commodity data for Chemicals and allied products-Rock salt, not seasonally adjusted	WPU06130271	Eastern: 33% North Central: 30% South Central:25% Southwest: 25% Olympic: 26% Northwest: 24%
Chemical Manufacturing	PPI Industry data for Other basic inorganic chemical manufacturing – Primary products, not seasonally adjusted	PCU32518032518P	Eastern: 3% North Central: 3% South Central:3% Southwest: 3% Olympic: 3% Northwest: 3%
Rail Transportation	PPI industry sub-sector data for Rail transportation, not seasonally adjusted	PCU482---482---	Eastern: 44% North Central: 42% South Central:40% Southwest: 40% Olympic: 42% Northwest: 44%
Truck Transportation	PPI industry sub-sector data for Truck transportation, not seasonally adjusted	PCU484---484---	Eastern: 20% North Central: 25% South Central:32% Southwest: 32% Olympic: 29% Northwest: 29%

CATEGORY	PPI NAME	PPI CODE	<b>CATEGORY 8A-B:</b> STANDARD GRADATION, BRINING SALT (USED AS ROAD SALT) <b>CATEGORY 8A-R:</b> STANDARD GRADATION, ROAD SALT <b>CATEGORY 8C-R:</b> FINE GRADATION ROAD SALT <b>CATEGORY 8C-B:</b> FINE GRADATION, BRINING SALT PERCENTAGE
Rock Salt	PPI Commodity data for Chemicals and allied products-Rock salt, not seasonally adjusted	WPU06130271	Eastern: 40% North Central: 35% South Central: 31% Southwest: 31% Olympic: 33% Northwest: 29%
Rail Transportation	PPI industry sub-sector data for Rail transportation, not seasonally adjusted	PCU482---482---	Eastern: 41% North Central: 36% South Central: 38% Southwest: 37% Olympic: 38% Northwest: 42%
Truck Transportation	PPI industry sub-sector data for Truck transportation, not seasonally adjusted	PCU484---484---	Eastern: 19% North Central: 29% South Central: 31% Southwest: 32% Olympic: 29% Northwest: 29%

(b) Price Adjustment for Diesel Fuel Surcharges or Credit to the Purchaser (“Costs”). Beginning April 1, 2024, as set forth in this section, for each invoice, Contractor, as appropriate based on diesel fuel cost changes, shall:

- Include a diesel fuel surcharge to the Purchaser (in the event of an increase in diesel fuel costs resulting in an adjustment);
- Include an invoice credit to the Purchaser (in the event of a decrease in diesel fuel costs resulting in an adjustment); or
- State that there is no applicable diesel fuel surcharge or invoice credit (in the event that diesel fuel costs are unchanged, or the change is insufficient to result in an adjustment).

Price adjustments for diesel fuel costs shall be determined and calculated as follows:

- Baseline Diesel Fuel Cost. The parties shall utilize a baseline price for diesel fuel, which shall be the contract average rack price per gallon for ultra-low #2 diesel fuel (USLD #2 Clear) for Spokane, Washington for March 20, 2024 as reported by the Oil Price Information Service (OPIS) in the OPIS Report subscribed to and received by Enterprise Services.
- Determining Diesel Fuel Cost Changes. The Contract Administrator shall verify and record the OPIS pricing for March 20, 2024 (the baseline price) and, during the remainder of the Contract, for the 20th of each month (or nearest business day). Enterprise Services shall calculate and determine whether diesel fuel cost have increased, decreased, or remained the same and post the relevant data to the Enterprise Services' contract webpage.
- Diesel Fuel Cost Adjustments. The Parties agree that, notwithstanding diesel fuel price changes, there shall be no diesel fuel price adjustment unless the price change (whether an increase or a decrease) is five percent (5%) or more from the Baseline Diesel Fuel Price, this change would be reflected in a Diesel Fuel Cost adjustment. If, however, the price change increase or decrease is less than five percent (5%), there shall not be a Diesel Fuel Cost adjustment. The diesel fuel price adjustment shall be \$0.01 per mile for every \$0.05 change in diesel fuel price and shall be applied to the established miles between points in the Purchase Order. Mileage shall be disclosed on each invoice and may be verified by the Purchaser prior to acceptance of a Diesel Fuel Costs.

*Example 1 (OPIS Increase):*

- Baseline price of diesel fuel is \$3.00/gallon.
- OPIS reports the new diesel fuel price is \$3.15/gallon.
- The price change is \$0.15/gallon  $\$3.15$  (new price per gallon) -  $\$3.00$  (baseline price per gallon) =  $\$0.15$  (price change per gallon).
- The price change is five percent (5%)  $\$3.15$  (new price per gallon) -  $\$3.00$  (baseline price per gallon) =  $\$0.15$  (price change), and  $\$.15$  (price change) /  $\$3.00$  (baseline price per gallon) =  $.05$ , which is five percent (5%) or more, which is the threshold for a diesel fuel price adjustment).
- Accordingly, Contractor may include a Diesel Fuel Surcharge of \$0.03/mile (which is the \$0.01/per mile for every \$0.05 change in the

diesel fuel price and here there is a \$0.15 change and  $\$0.15/\$0.05 = 3$ ).

- If Contractor's mileage for Purchaser is 100 miles round trip, Contractor may include a Diesel Fuel Surcharge of \$3.00 [ $\$0.03/\text{mile} \times 100 \text{ miles} = \$3.00$ ].

*Example 2 (OPIS Decrease):*

- Baseline price of diesel fuel is \$3.00/gallon.
- OPIS reports the new diesel fuel price is \$2.70/gallon.
- The price change is ten percent (10%) [ $\$3.00$  (baseline price per gallon) -  $\$2.70$  (new price per gallon) =  $\$0.30$  (price change), and  $\$3.00$  (baseline price)/ $\$0.30$  (price change) = 10 percent], which is five percent (5%) or more, which is the threshold for a diesel fuel price adjustment).
- Contractor must credit \$0.06/mile (which is the \$0.01/per mile for every \$0.05 change in the diesel fuel price and here there is a \$0.30 change and  $\$0.30/\$0.05 = 6$ ).
- If Contractor's mileage for Purchaser is 100 miles round trip, Contractor must include a Diesel Fuel Credit to Purchaser in the amount of \$6.00.
- Effective date of price adjustment for diesel fuel costs. Price adjustments for diesel fuel costs, if applicable, shall be effective on the first day of the subsequent month. The parties understand and agree that such adjustments shall be considered an administrative action and shall not require an amendment to this Contract.

Contractor will invoice a separate line item indicating diesel fuel credit and mileage. If the fuel price returns to the baseline, surcharges may no longer be charged.

2. **80 / 120 VOLUME COMMITMENTS.** Section 9 of the Contract is hereby amended by deleting the existing Section 9 in its entirety and inserting the following in lieu thereof:

**9. 80/120 ANNUAL PURCHASE VOLUME COMMITMENTS.**

- 9.1 **80/120 ANNUAL PURCHASE VOLUME COMMITMENT.** Pursuant to this Contract, Contractor shall enable Purchasers to Participate, subject to the terms and conditions set forth herein, in an '80/120 Annual Purchase Volume Commitment' program. Such 80/120 Annual Purchase Volume Commitment requires Purchaser to notify Contractor of its intended annual purchase target volume and requires Purchaser to guarantee to Contractor that Purchaser shall pay for 80% of such target volume



regardless of whether Purchaser's actual orders reach 80% of the target volume. Similarly, Contractor guarantees to Purchaser that, if requested by Purchaser, Contractor shall deliver to Purchaser up to 120% of such target volume within the agreed upon time period.

9.2 PURCHASER OPTION TO PARTICIPATE. Purchasers, optionally at their discretion, shall have the right, on an annual basis, to participate in an 80/120 Annual Purchase Volume Commitment for the products identified below subject to the following:

- (a) To participate in an 80/120 Annual Purchase Volume Commitment, Purchaser timely must submit to Contractor the 80/120 Annual Purchase Volume Commitment Form no later than August 31st;
- (b) Purchaser's 80/120 Annual Purchase Volume Commitment Form must state a 'target volume' representing 100% of Purchaser's estimated aggregate need, by included product, for such snow and ice control products for the coming snow season. The aggregate volume commitments total shall include the products purchased between July 1st of the current year and June 30th of the following year.
- (c) Contractor shall sign Purchaser's 80/120 Annual Volume Commitment Form and return the same to Purchaser no later than September 15th of each year.
- (d) Pursuant to the 80/120 Annual Purchase Volume Commitment, Purchaser guarantees to Contractor that Purchaser shall pay for 80% of Purchaser's stated target volume regardless of whether Purchaser's actual orders reach 80% of such target volume.
- (e) Pursuant to the 80/120 Annual Purchase Volume Commitment, Contractor guarantees to Purchaser that, if requested by Purchaser, Contractor shall deliver to Purchaser up to 120% of Purchaser's target volume within the agreed upon time period.

9.3 SNOW & ICE PRODUCTS INCLUDED IN THE 80/120 ANNUAL PURCHASE VOLUME COMMITMENT. Contractor shall allow Purchasers to include each of the following products in an 80/120 Annual Purchase Volume Commitment:

- Category 1: Corrosion Inhibited Liquid Magnesium Chloride;
- Category 2: Corrosion Inhibited Liquid Calcium Chloride;
- Category 4C: Corrosion Inhibited Solid Sodium Chloride - Grade 2;
- Category 8A-R: Standard Gradation Road Salt; and
- Category 8B: Standard Gradation Road Salt, Insoluble Material.

3. NONDISCRIMINATION. The following provision is added as a new Section 19.24 to the Contract:

19.24. NONDISCRIMINATION.

- (a) Nondiscrimination Requirement. During the term of this Contract, Contractor, including any subcontractor, shall not discriminate on the bases enumerated at RCW 49.60.530(3). In addition, Contractor, including any subcontractor, shall give written notice of this

nondiscrimination requirement to any labor organizations with which Contractor, or subcontractor, has a collective bargaining or other agreement.

- (b) Obligation to Cooperate. Contractor, including any subcontractor, shall cooperate and comply with any Washington state agency investigation regarding any allegation that Contractor, including any subcontractor, has engaged in discrimination prohibited by this Contract pursuant to RCW 49.60.530(3).
- (c) Default. Notwithstanding any provision to the contrary, Enterprise Services may suspend Contractor, including any subcontractor, upon notice of a failure to participate and cooperate with any state agency investigation into alleged discrimination prohibited by this Contract, pursuant to RCW 49.60.530(3). Any such suspension will remain in place until Enterprise Services receives notification that Contractor, including any subcontractor, is cooperating with the investigating state agency. In the event Contractor, or subcontractor, is determined to have engaged in discrimination identified at RCW 49.60.530(3), Enterprise Services may terminate this Contract in whole or in part, and Contractor, subcontractor, or both, may be referred for debarment as provided in RCW 39.26.200. Contractor or subcontractor may be given a reasonable time in which to cure this noncompliance, including implementing conditions consistent with any court-ordered injunctive relief or settlement agreement.
- (d) Remedies for Breach. Notwithstanding any provision to the contrary, in the event of Contract termination or suspension for engaging in discrimination, Contractor, subcontractor, or both, shall be liable for contract damages as authorized by law including, but not limited to, any cost difference between the original Contract and the replacement or cover contract and all administrative costs directly related to the replacement contract, which damages are distinct from any penalties imposed under Chapter 49.60, RCW. Enterprise Services and/or Purchasers shall have the right to deduct from any monies due to Contractor or subcontractor, or that thereafter become due, an amount for damages Contractor or subcontractor will owe Enterprise Services and/or Purchasers for default under this provision.

- 4. INSURANCE REQUIREMENTS. The Contract is hereby amended by deleting the existing **Exhibit C – Insurance Requirements** in its entirety and inserting the attached **Exhibit C – Insurance Requirements** (dated April 15, 2024). As of the effective date of this Amendment, any reference to **Exhibit C – Insurance Requirements** shall be deemed to be a reference to the attached **Exhibit C – Insurance Requirements** (dated April 15, 2024).
- 5. NO CHANGE OTHER THAN AMENDMENT. Except as amended herein, the Contract is unaffected and remains in full force and effect.
- 6. INTEGRATED AGREEMENT; MODIFICATION. This Amendment constitutes the entire agreement and understanding of the Parties with respect to the subject matter and supersedes all prior

negotiations and representations. In the event of any conflict between this Amendment and the Contract or any earlier amendment, this Amendment shall control and govern. This Amendment may not be modified except in writing signed by the Parties.

7. **AUTHORITY.** Each party to this Amendment, and each individual signing on behalf of each party, hereby represents and warrants to the other that it has full power and authority to enter into this Amendment and that its execution, delivery, and performance of this Amendment has been fully authorized and approved, and that no further approvals or consents are required to bind such party.
8. **ELECTRONIC SIGNATURES.** An electronic signature or electronic record of this Amendment or any other ancillary agreement shall be deemed to have the same legal effect as delivery of an original executed copy of this Amendment or such other ancillary agreement for all purposes.
9. **COUNTERPARTS.** This Amendment may be executed in one or more counterparts, each of which shall be deemed an original, and all of which counterparts together shall constitute the same instrument which may be sufficiently evidenced by one counterpart. Execution of this Amendment at different times and places by the parties shall not affect the validity thereof so long as all the parties hereto execute a counterpart of this Amendment.

EXECUTED AND EFFECTIVE as of the day and date first above written.

**SALT DISTRIBUTORS, INC.**  
**A WASHINGTON CORPORATION**

By:     *Nic Binczewski*      
Name:     Nic Binczewski      
Title:     VP      
Date:     4-11-24    

**STATE OF WASHINGTON**  
**DEPARTMENT OF ENTERPRISE SERVICES**

By:     Theresa Jensen     Digitally signed by Theresa Jensen  
Date: 2024.04.12 05:59:56 -07'00'  
Name:     Theresa Jensen      
Title:     Procurement Supervisor      
Date:     April 12, 2024

**INSURANCE REQUIREMENTS  
DATED APRIL 15, 2024**

1. **INSURANCE OBLIGATION.** During the Term of this Contract, Contractor shall possess and maintain in full force and effect, at Contractor's sole expense, the following insurance coverages:
  - a. **COMMERCIAL GENERAL LIABILITY INSURANCE.** Commercial general liability insurance covering bodily injury, property damage, products/completed operations, personal injury, and advertising injury liability on an 'occurrence form' that shall be no less comprehensive and no more restrictive than the coverage provided by Insurance Services Office (ISO) under the most recent version of form CG 00 01 in the amount of not less than \$2,000,000 per occurrence and \$4,000,000 general aggregate. This coverage shall include blanket contractual liability coverage. This coverage shall include a cross-liability clause or separation of insured condition.
  - b. **WORKERS' COMPENSATION INSURANCE.** Contractor shall comply with applicable Workers' Compensation or Industrial Accident insurance providing benefits as required by law.
  - c. **EMPLOYERS' LIABILITY (STOP GAP) INSURANCE.** Employers' liability insurance with limits not less than \$1,000,000 each accident for bodily injury by accident, \$1,000,000 each employee for bodily injury by disease, and \$1,000,000 bodily injury by disease policy limit.
  - d. **COMMERCIAL AUTOMOBILE LIABILITY INSURANCE.** (If applicable, as set forth below) Commercial automobile liability insurance covering the ownership, maintenance, and/or use of all owned/leased, non-owned, and hired vehicles used in the performance of the Contract, with limits of not less than \$5,000,000 per accident, with a combined single limit for bodily injury and property damage liability. Coverage shall be provided on Insurance Services Office (ISO) form number CA 00 01 or an equivalent. If pollutants are to be transported, MCS 90 and CA 9948 (in transit pollution risks coverage) endorsements are required unless in-transit pollution risk is covered under a pollution liability insurance policy.
  - e. **POLLUTION LIABILITY INSURANCE.** (If applicable, as set forth below) Pollution Liability applicable to the work being performed, with a limit no less than \$2,000,000 per claim or occurrence and \$5,000,000 aggregate per policy period of one year. The Pollution Liability policy shall be endorsed to include pollution coverage while in transit, covering materials to be transported by Contractor pursuant to the Contract.
  - f. **TRANSPORTATION POLLUTION LIABILITY COVERAGE.** (If applicable, as set forth below) Transportation pollution liability insurance in an amount not less than \$2,000,000 per occurrence and \$5,000,000 aggregate.

Contractor must have either a Transportation Pollution Liability Insurance, or as an alternative have a Commercial Automobile Liability or Pollution Liability policy as long as such policy is endorsed to include any pollution related claim or occurrence when the Goods are in transit to the Purchasers. If the Contractor uses a third-party commercial transportation provider to deliver all Goods to the Purchasers under this Contract, and such provider has the pollution related coverages as required above, the Contractor does not need to have their own the pollution insurance coverages.

The required limits can be satisfied by any combination of primary, umbrella, or excess policy. The insurance coverage limits set forth herein are the minimum. Contractor's insurance coverage shall be no less than the minimum amounts specified. Coverage in the amounts of these minimum limits, however, shall not be construed to relieve Contractor from liability in excess of such limits. Contractor waives all rights against the State of Washington for the recovery of damages to the extent such damages are covered by any insurance required herein.

2. **INSURANCE CARRIER RATING.** Coverages provided by Contractor must be underwritten by an insurance company deemed acceptable to the State of Washington's Office of Risk Management. Insurance coverage shall be provided by companies authorized to do business within the State of Washington and rated A- Class VII or better in the most recently published edition of Best's Insurance Rating. Enterprise Services reserves the right to reject all or any insurance carrier(s) with an unacceptable financial rating.
3. **ADDITIONAL INSURED.** Commercial General Liability, Commercial Automobile Liability, and Pollution Liability Insurance shall include the State of Washington and all authorized Purchasers (and their agents, officers, and employees) as Additional Insureds evidenced by copy of the Additional Insured Endorsement attached to the Certificate of Insurance on such insurance policies.
4. **CERTIFICATE OF INSURANCE.** Contractor shall furnish to Enterprise Services, as evidence of the insurance coverage required by this Contract, a certificate of insurance satisfactory to Enterprise Services that insurance, in the above-stated kinds and minimum amounts, has been secured. In addition, no less than ten (10) calendar days prior to coverage expiration, Contractor shall furnish to Enterprise Services an updated or renewed certificate of insurance, satisfactory to Enterprise Services, that insurance, in the above-stated kinds and minimum amounts, has been secured. Failure to maintain or provide proof of insurance, as required, will result in contract cancellation. **All policies and certificates of insurance shall include the Contract number stated on the cover of this Contract.** All certificates of Insurance and any related insurance documents shall be delivered to Enterprise Services by email to the email address set forth below or to such other address or email address as Enterprise Services may specify in writing:

[descontractsteamcedar@des.wa.gov](mailto:descontractsteamcedar@des.wa.gov)

*Note:* The Email Subject line must state:

**Email**

Contract Insurance Certificate – Statewide Contract No. 11021 – Snow & Ice Control Products

5. **PRIMARY COVERAGE.** Contractor's insurance shall apply as primary and shall not seek contribution from any insurance or self-insurance maintained by, or provided to, the additional insureds listed above including, at a minimum, the State of Washington and/or any Purchaser. All insurance or self-insurance of the State of Washington and/or Purchasers shall be excess of any insurance provided by Contractor or subcontractors.
6. **SUBCONTRACTORS.** Contractor shall include all subcontractors as insureds under all required insurance policies. Alternatively, prior to utilizing any subcontractor, Contractor shall cause any such subcontractor to provide insurance that complies with all applicable requirements of the insurance set forth herein and shall furnish separate Certificates of Insurance and endorsements for each subcontractor. Each subcontractor must comply fully with all insurance requirements stated herein. Failure of any subcontractor to comply with insurance requirements does not limit Contractor's liability or responsibility.

7. **WAIVER OF SUBROGATION.** Contractor waives all rights of subrogation against the State of Washington and any Purchaser for the recovery of damages to the extent such damages are or would be covered by the insurance specified herein.
8. **NOTICE OF CHANGE OR CANCELLATION.** There shall be no cancellation, material change, exhaustion of aggregate limits, or intent not to renew insurance coverage, either in whole or in part, without at least sixty (60) calendar days prior written Legal Notice by Contractor to Enterprise Services. Failure to provide such notice, as required, shall constitute default by Contractor. Any such written notice shall include the Contract number stated on the cover of this Contract.
9. **EXTENDED REPORTING PERIOD.** If any required insurance coverage is on a claims-made basis (rather than occurrence), Contractor shall maintain such coverage for a period of no less than three (3) years following expiration or termination of the Contract. \* \* \* END OF INSURANCE REQUIREMENTS \* \* \*

PRICES FOR GOODS  
DATED APRIL 15, 2024

**Category 4C**  
**Corrosion Inhibited Solid Sodium Chloride - Grade 2, Maximum Moisture Content**  
**5% Standard Gradation**

Anti-Caking Agent:	Proprietary Blend of Additives
Product:	Ice Kicker
Drop Shipment:	\$75

**WSDOT Region 1 Northwest**

Order/Delivery Area	3 Days	7 Days	30 Days
Maintenance Area 1	\$228.72	\$221.29	\$215.99
Maintenance Area 2	\$229.98	\$222.56	\$217.25
Maintenance Area 3	\$226.91	\$219.49	\$214.19
Maintenance Area 4	\$208.53	\$201.10	\$195.80
Maintenance Area 5	\$214.66	\$207.23	\$201.93

**WSDOT Region 2 North Central**

Order/Delivery Area	3 Days	7 Days	30 Days
Maintenance Area 1	\$202.36	\$194.95	\$189.66
Maintenance Area 2	\$187.37	\$179.96	\$174.66
Maintenance Area 3	\$207.46	\$200.05	\$194.75

**WSDOT Region 3 Olympic**

Order/Delivery Area	3 Days	7 Days	30 Days
Maintenance Area 1	\$203.81	\$196.39	\$191.09
Maintenance Area 2	\$212.53	\$205.11	\$198.75
Maintenance Area 3	\$226.79	\$219.37	\$214.07
Maintenance Area 4	\$212.66	\$205.24	\$199.94

**WSDOT Region 4 Southwest**

Order/Delivery Area	3 Days	7 Days	30 Days
Maintenance Area 1	\$229.83	\$222.41	\$217.11
Maintenance Area 2	\$207.89	\$200.47	\$207.92
Maintenance Area 3	\$223.70	\$216.28	\$210.99
Maintenance Area 4	\$212.66	\$205.24	\$199.94

**WSDOT Region 5 South Central**

Order/Delivery Area	3 Days	7 Days	30 Days
Maintenance Area 1	\$211.44	\$204.02	\$198.73
Maintenance Area 2	\$207.89	\$200.47	\$195.18
Maintenance Area 3	\$190.61	\$183.19	\$177.89
Maintenance Area 4	\$193.95	\$186.53	\$181.23

**WSDOT Region 6 Eastern**

Order/Delivery Area	3 Days	7 Days	30 Days
Maintenance Area 1	\$185.12	\$177.71	\$172.41
Maintenance Area 2	\$185.82	\$178.41	\$173.11
Maintenance Area 3	\$186.47	\$179.05	\$173.76
Maintenance Area 4	\$192.49	\$185.08	\$179.78

**Category 8A-B  
Standard Gradation Brining Salt**

Anti-Caking Agent:	None
Product:	Drinox Extra Coarse
Drop Shipment:	\$75

**WSDOT Region 1 Northwest**

Order/Delivery Area	3 Days	7 Days	30 Days
Maintenance Area 1	\$232.39	\$225.01	\$219.74
Maintenance Area 2	\$239.78	\$232.39	\$225.01
Maintenance Area 3	\$236.59	\$229.21	\$223.93
Maintenance Area 4	\$218.30	\$210.92	\$205.64
Maintenance Area 5	\$224.40	\$217.01	\$211.74

**WSDOT Region 2 North Central**

Order/Delivery Area	3 Days	7 Days	30 Days
Maintenance Area 1	\$211.03	\$203.66	\$198.40
Maintenance Area 2	\$196.12	\$188.75	\$183.49
Maintenance Area 3	\$216.10	\$208.73	\$203.46

**WSDOT Region 3 Olympic**

Order/Delivery Area	3 Days	7 Days	30 Days
Maintenance Area 1	\$213.46	\$206.08	\$200.82
Maintenance Area 2	\$222.13	\$214.76	\$208.43
Maintenance Area 3	\$236.30	\$228.93	\$223.66
Maintenance Area 4	\$230.21	\$222.84	\$205.82



**WSDOT Region 4 Southwest**

Order/Delivery Area	3 Days	7 Days	30 Days
Maintenance Area 1	\$239.39	\$232.02	\$226.75
Maintenance Area 2	\$228.15	\$220.77	\$217.61
Maintenance Area 3	\$233.30	\$225.92	\$220.66
Maintenance Area 4	\$218.46	\$211.09	\$205.82

**WSDOT Region 5 South Central**

Order/Delivery Area	3 Days	7 Days	30 Days
Maintenance Area 1	\$216.13	\$208.76	\$206.65
Maintenance Area 2	\$211.09	\$203.71	\$198.44
Maintenance Area 3	\$211.61	\$204.24	\$198.97
Maintenance Area 4	\$198.74	\$191.36	\$189.25

**WSDOT Region 6 Eastern**

Order/Delivery Area	3 Days	7 Days	30 Days
Maintenance Area 1	\$187.83	\$180.46	\$175.20
Maintenance Area 2	\$188.52	\$181.16	\$175.89
Maintenance Area 3	\$189.17	\$181.80	\$176.53
Maintenance Area 4	\$195.16	\$187.79	\$182.52

**Category 8A-R  
Standard Gradation Road Salt**

Anti-Caking Agent:	none
Product:	Drinox Extra Coarse
Drop Shipment:	\$75

**WSDOT Region 1 Northwest**

Order/Delivery Area	3 Days	7 Days	30 Days
Maintenance Area 1	\$232.39	\$225.01	\$219.74
Maintenance Area 2	\$239.78	\$232.39	\$225.01
Maintenance Area 3	\$236.59	\$229.21	\$223.93
Maintenance Area 4	\$218.30	\$210.92	\$205.64
Maintenance Area 5	\$224.40	\$217.01	\$211.74

**WSDOT Region 2 North Central**

Order/Delivery Area	3 Days	7 Days	30 Days
Maintenance Area 1	\$211.03	\$203.66	\$198.40
Maintenance Area 2	\$196.12	\$188.75	\$183.49
Maintenance Area 3	\$216.10	\$208.73	\$203.46

**WSDOT Region 3 Olympic**

Order/Delivery Area	3 Days	7 Days	30 Days
Maintenance Area 1	\$213.46	\$206.08	\$200.82
Maintenance Area 2	\$222.13	\$214.76	\$208.43
Maintenance Area 3	\$236.30	\$228.93	\$223.66
Maintenance Area 4	\$230.21	\$222.84	\$217.57

**WSDOT Region 4 Southwest**

Order/Delivery Area	3 Days	7 Days	30 Days
Maintenance Area 1	\$239.39	\$232.02	\$226.75
Maintenance Area 2	\$228.15	\$220.77	\$217.61
Maintenance Area 3	\$233.30	\$225.92	\$220.66
Maintenance Area 4	\$218.46	\$211.09	\$205.82

**WSDOT Region 5 South Central**

Order/Delivery Area	3 Days	7 Days	30 Days
Maintenance Area 1	\$216.18	\$208.80	\$206.69
Maintenance Area 2	\$211.13	\$203.75	\$198.48
Maintenance Area 3	\$211.65	\$204.28	\$199.01
Maintenance Area 4	\$198.77	\$191.40	\$189.29

**WSDOT Region 6 Eastern**

Order/Delivery Area	3 Days	7 Days	30 Days
Maintenance Area 1	\$187.83	\$180.46	\$175.20
Maintenance Area 2	\$188.52	\$181.16	\$175.89
Maintenance Area 3	\$187.17	\$181.80	\$176.53
Maintenance Area 4	\$195.16	\$187.79	\$182.52

**Category 8B  
Solid Sodium Chloride**

Anti-Caking Agent:	YPS
Product:	Qwiksalt
Drop Shipment:	\$75

**WSDOT Region 1 Northwest**

Order/Delivery Area	3 Days	7 Days	30 Days
Maintenance Area 1	\$201.40	\$193.99	\$188.70
Maintenance Area 2	\$206.69	\$199.28	\$193.99
Maintenance Area 3	\$199.60	\$192.19	\$186.90
Maintenance Area 4	\$182.30	\$174.89	\$168.54
Maintenance Area 5	\$187.36	\$179.95	\$174.66

**WSDOT Region 2 North Central**

Order/Delivery Area	3 Days	7 Days	30 Days
Maintenance Area 1	\$173.53	\$166.13	\$160.85
Maintenance Area 2	\$163.85	\$156.45	\$151.16
Maintenance Area 3	\$178.62	\$171.22	\$165.93

**WSDOT Region 3 Olympic**

Order/Delivery Area	3 Days	7 Days	30 Days
Maintenance Area 1	\$176.52	\$166.11	\$163.82
Maintenance Area 2	\$184.16	\$176.76	\$171.47
Maintenance Area 3	\$199.45	\$192.04	\$186.75
Maintenance Area 4	\$193.33	\$185.93	\$180.64

**WSDOT Region 4 Southwest**

Order/Delivery Area	3 Days	7 Days	30 Days
Maintenance Area 1	\$202.47	\$195.06	\$189.78
Maintenance Area 2	\$193.30	\$185.89	\$180.61
Maintenance Area 3	\$196.35	\$188.95	\$183.66
Maintenance Area 4	\$189.06	\$181.65	\$176.37

**WSDOT Region 5 South Central**

Order/Delivery Area	3 Days	7 Days	30 Days
Maintenance Area 1	\$181.73	\$174.33	\$169.04
Maintenance Area 2	\$182.94	\$175.54	\$168.13
Maintenance Area 3	\$173.21	\$165.81	\$160.52
Maintenance Area 4	\$174.85	\$167.44	\$162.16

**WSDOT Region 6 Eastern**

Order/Delivery Area	3 Days	7 Days	30 Days
Maintenance Area 1	\$157.79	\$150.39	\$137.58
Maintenance Area 2	\$153.20	\$145.80	\$137.33
Maintenance Area 3	\$155.96	\$148.56	\$136.92
Maintenance Area 4	\$162.42	\$155.01	\$150.78

**Category 8C-R  
Fine Gradation Road Salt**

Anti-Caking Agent:	None
Product:	Medium Solar Salt
Drop Shipment:	\$75

**WSDOT Region 1 Northwest**

Order/Delivery Area	3 Days	7 Days	30 Days
Maintenance Area 1	\$220.30	\$213.30	\$208.30
Maintenance Area 2	\$227.30	\$220.30	\$213.30
Maintenance Area 3	\$224.28	\$217.28	\$212.28
Maintenance Area 4	\$206.94	\$199.94	\$194.94
Maintenance Area 5	\$212.72	\$205.72	\$200.72

**WSDOT Region 2 North Central**

Order/Delivery Area	3 Days	7 Days	30 Days
Maintenance Area 1	\$200.41	\$193.41	\$188.41
Maintenance Area 2	\$186.25	\$179.25	\$174.25
Maintenance Area 3	\$205.22	\$198.22	\$193.22

**WSDOT Region 3 Olympic**

Order/Delivery Area	3 Days	7 Days	30 Days
Maintenance Area 1	\$202.60	\$195.60	\$190.60
Maintenance Area 2	\$210.83	\$203.83	\$197.83
Maintenance Area 3	\$224.28	\$217.28	\$212.28
Maintenance Area 4	\$218.50	\$211.50	\$206.50

**WSDOT Region 4 Southwest**

Order/Delivery Area	3 Days	7 Days	30 Days
Maintenance Area 1	\$227.17	\$220.17	\$215.17
Maintenance Area 2	\$216.50	\$209.50	\$206.50
Maintenance Area 3	\$221.39	\$214.39	\$209.39
Maintenance Area 4	\$207.31	\$200.31	\$195.31

**WSDOT Region 5 South Central**

Order/Delivery Area	3 Days	7 Days	30 Days
Maintenance Area 1	\$205.10	\$198.10	\$196.10
Maintenance Area 2	\$200.31	\$193.31	\$188.31
Maintenance Area 3	\$200.81	\$193.81	\$188.81
Maintenance Area 4	\$188.59	\$181.59	\$179.59

**WSDOT Region 6 Eastern**

Order/Delivery Area	3 Days	7 Days	30 Days
Maintenance Area 1	\$178.41	\$171.41	\$166.41
Maintenance Area 2	\$179.07	\$172.07	\$167.07
Maintenance Area 3	\$179.68	\$172.68	\$167.68
Maintenance Area 4	\$185.37	\$178.37	\$173.37

**Category 8C-B**

**Fine Gradation Brining Salt**

Anti-Caking Agent:	None
Product:	Medium Solar Salt
Drop Shipment:	\$75

**WSDOT Region 1 Northwest**

Order/Delivery Area	3 Days	7 Days	30 Days
Maintenance Area 1	\$220.30	\$213.30	\$208.30
Maintenance Area 2	\$227.30	\$220.30	\$213.30
Maintenance Area 3	\$224.28	\$217.28	\$212.28
Maintenance Area 4	\$206.94	\$199.94	\$194.94
Maintenance Area 5	\$212.72	\$205.72	\$200.72

**WSDOT Region 2 North Central**

Order/Delivery Area	3 Days	7 Days	30 Days
Maintenance Area 1	\$200.41	\$193.41	\$188.41
Maintenance Area 2	\$186.25	\$179.25	\$174.25
Maintenance Area 3	\$205.22	\$198.22	\$193.22

**WSDOT Region 3 Olympic**

Order/Delivery Area	3 Days	7 Days	30 Days
Maintenance Area 1	\$202.60	\$195.60	\$190.60
Maintenance Area 2	\$210.83	\$203.83	\$197.83
Maintenance Area 3	\$224.28	\$217.28	\$212.28
Maintenance Area 4	\$218.50	\$211.50	\$206.50

**WSDOT Region 4 Southwest**

Order/Delivery Area	3 Days	7 Days	30 Days
Maintenance Area 1	\$227.17	\$220.17	\$215.17
Maintenance Area 2	\$216.50	\$209.50	\$206.50
Maintenance Area 3	\$221.39	\$214.39	\$209.39
Maintenance Area 4	\$207.31	\$200.31	\$195.31

**WSDOT Region 5 South Central**

Order/Delivery Area	3 Days	7 Days	30 Days
Maintenance Area 1	\$205.10	\$198.10	\$196.10
Maintenance Area 2	\$200.31	\$193.31	\$188.31
Maintenance Area 3	\$200.81	\$193.81	\$188.81
Maintenance Area 4	\$188.59	\$181.59	\$179.59

**WSDOT Region 6 Eastern**

Order/Delivery Area	3 Days	7 Days	30 Days
Maintenance Area 1	\$178.41	\$171.41	\$166.41
Maintenance Area 2	\$179.07	\$172.07	\$167.07
Maintenance Area 3	\$179.68	\$172.68	\$167.68
Maintenance Area 4	\$185.37	\$178.37	\$173.37

State of Washington Contracts & Procurement Division Department of Enterprise Services P.O. Box 41411 Olympia, WA 98504-1411	<b>CONTRACT AMENDMENT</b>	
	Contract No.:	11021
Salt Distributors, Inc 15201 E. Marietta Ave. Spokane Valley, WA 99216	Amendment No.:	3
	Effective Date:	10-15-2023

**THIRD AMENDMENT  
TO  
CONTRACT NO. 11021  
SNOW & ICE CONTROL PRODUCTS**

This Third Amendment ("Amendment") to Contract No. 11021 is made and entered into by and between the State of Washington acting by and through the Department of Enterprise Services, a Washington State governmental agency ("Enterprise Services") and Salt Distributors, Inc, a Washington corporation ("Contractor") and is dated and effective as of October 15, 2023.

**RECITALS**

- A. Enterprise Services and Contractor (collectively the "Parties") entered into that certain Contract No. 11021 dated effective as of August 1, 2022 ("Contract").
- B. The Parties previously amended the Contract October 3, 2022 to reflect order commitments for 80/120 for the winter 2022-2023 season and on October 1, 2023.
- C. The Parties now desire to change the yearly target commitments.
- D. The amendment set forth herein is within the scope of the Contract.

**AGREEMENT**

NOW THEREFORE, in consideration of the mutual covenants and agreements set forth herein, the Parties hereby agree to amend the Contract, as previously amended, as follows:

- 1. 80/120 TARGET COMMITMENTS. The parties agree that these are the winter maintenance season 2023-2024 target commitments for WSDOT Regions and Political Subdivisions:

Vendor	SDI				
Category	#4C				
Product Name	Ice Kicker				
Customer	WSDOT	80%	Target (100%)	120%	Unit of Measure
	Northwest				
	North Central	4480	5600	6720	
	Olympic				
	Southwest				

	South Central				
	Eastern	8000	10000	12000	Tons
Category	8AB				
Product Name	DRI ROX				
Customer	WSDOT	80%	Target (100%)	120%	Unit of Measure
	Northwest				
	North Central	180	225	270	Tons
	Olympic				
	Southwest				
	South Central				
	Eastern	180	225	270	Tons
Category	8B				
Product Name	Quick Salt				
Customer	WSDOT	80%	Target (100%)	120%	Unit of Measure
	Northwest				
	North Central				
	Olympic				
	Southwest				
	South Central				
	Eastern	5120	6400	7680	Tons
Category	<del>8C-B</del>				
Product Name	<del>Medium Solar Salt</del> <i>Dri-Rox NB</i>				
Customer		80%	Target (100%)	120%	Unit of Measure
WSDOT	Northwest				
	North Central				
	Olympic				
	Southwest				
	South Central				
	Eastern	336	420	504	Tons
Category	8C-B	Medium Solar			
Customer	Region	80%	Target (100%)	120%	Unit of Measure
City of Redmond	Northwest	140	175	210	Tons
<del>Chelan County</del>	<del>North Central</del>	<del>2240</del>	<del>2800</del>	<del>3360</del>	<del>Tons</del>
Grays Harbor County	Olympic	144	180	216	Tons
Pierce County	Olympic	520	650	780	Tons
Category	8A-R	Dri-Rox			

ice kick  
 NB  
 ice kick  
 ice kick →  
 kick



Drinox →  
 ee →  
 Kicker →  
 Drinox →

Customer	Region	80%	Target (100%)	120%	Unit of Measure
City of Federal Way	Northwest	144	180	216	Tons
WDVA-Port Orchard	Olympic	32	40	48	Tons
City of Puyallup	Olympic	96	120	144	Tons
Category	4-C	Ice Kicker			
Customer	Region	80%	Target (100%)	120%	Unit of Measure
City of Wenatchee	North Central	320	400	480	Tons
Snohomish County	Northwest	320	400	480	Tons

2. NO CHANGE OTHER THAN AMENDMENT. Except as amended herein, the Contract is unaffected and remains in full force and effect.
3. INTEGRATED AGREEMENT; MODIFICATION. This Amendment constitutes the entire agreement and understanding of the Parties with respect to the subject matter and supersedes all prior negotiations and representations. In the event of any conflict between this Amendment and the Contract or any earlier amendment, this Amendment shall control and govern. This Amendment may not be modified except in writing signed by the Parties.
4. AUTHORITY. Each party to this Amendment, and each individual signing on behalf of each party, hereby represents and warrants to the other that it has full power and authority to enter into this Amendment and that its execution, delivery, and performance of this Amendment has been fully authorized and approved, and that no further approvals or consents are required to bind such party.
5. ELECTRONIC SIGNATURES. An electronic signature of this Amendment or any other ancillary agreement shall be deemed to have the same legal effect as delivery of an original executed copy of this Amendment or such other ancillary agreement for all purposes.
6. COUNTERPARTS. This Amendment may be executed in one or more counterparts, each of which shall be deemed an original, and all of which counterparts together shall constitute the same instrument which may be sufficiently evidenced by one counterpart. Execution of this Amendment at different times and places by the parties shall not affect the validity thereof so long as all the parties hereto execute a counterpart of this Amendment.

EXECUTED AND EFFECTIVE AS of the day and date first above written.

SALT DISTRIBUTORS, INC  
A WASHINGTON CORPORATION

STATE OF WASHINGTON  
DEPARTMENT OF ENTERPRISE SERVICES

By:   
Name: Nick Kinczewski  
Title: VP  
Date: 10-11-23

By: Theresa Jensen Digitally signed by Theresa Jensen  
Date: 2024.02.12 17:17:14 -08'00'  
Name: THERESA JENSEN  
Title: PROCUREMENT SUPERVISOR  
Date: February 12, 2024

State of Washington Contracts & Procurement Division Department of Enterprise Services P.O. Box 41411 Olympia, WA 98504-1411	<b>CONTRACT AMENDMENT</b>	
	Contract No.:	11021
Salt Distributors, Inc 15201 E. Marietta Ave. Spokane Valley, WA 99216	Amendment No.:	2
	Effective Date:	10-1-2023

**SECOND AMENDMENT  
TO  
CONTRACT NO. 11021  
SNOW & ICE CONTROL PRODUCTS**

This Second Amendment (“Amendment”) to Contract No. 11021 is made and entered into by and between the State of Washington acting by and through the Department of Enterprise Services, a Washington State governmental agency (“Enterprise Services”) and Salt Distributors, Inc, a Washington corporation (“Contractor”) and is dated and effective as of October 1, 2023.

R E C I T A L S

- A. Enterprise Services and Contractor (collectively the “Parties”) entered into that certain Contract No. 11021 dated effective as of August 1, 2022 (“Contract”).
- B. The Parties previously amended the Contract October 3, 2022 to reflect order commitments for 80/120 for the winter 2022-2023 season.
- C. The Parties now desire to amend the Contract to update pricing.
- D. The amendment set forth herein is within the scope of the Contract.

A G R E E M E N T

NOW THEREFORE, in consideration of the mutual covenants and agreements set forth herein, the Parties hereby agree to amend the Contract, as previously amended, as follows:

1. ECONOMIC PRICE ADJUSTMENT. Pursuant to section 3.3 of the contract, the pricing for the goods/services is hereby amended by deleting the existing Exhibit B –Prices for Goods in its entirety and inserting the attached Exhibit B – Prices for Goods October 1, 2023. These prices include the agreed economic adjustment from Bureau of Labor and Statistics (BLS) index/indices: 3.60% PPI series WPU6130271; 19.26% PPI series PCU325180325180p; 6.84% PPI series PCU482482; 5.43% PPI series PCU484484; 20.70% PPI series PCU483111483111. Increases are based on individual vendor weighted adjustments per contractual agreements. There are multiple final negotiated weighted adjustments for this vendor based upon the categories. The contract pricing for the goods is hereby amended by deleting the existing Exhibit B – Prices for Goods in its entirety and inserting the attached Exhibit B – Prices for Goods October 1, 2023.

2. NO CHANGE OTHER THAN AMENDMENT. Except as amended herein, the Contract is unaffected and remains in full force and effect.
3. INTEGRATED AGREEMENT; MODIFICATION. This Amendment constitutes the entire agreement and understanding of the Parties with respect to the subject matter and supersedes all prior negotiations and representations. In the event of any conflict between this Amendment and the Contract or any earlier amendment, this Amendment shall control and govern. This Amendment may not be modified except in writing signed by the Parties.
4. AUTHORITY. Each party to this Amendment, and each individual signing on behalf of each party, hereby represents and warrants to the other that it has full power and authority to enter into this Amendment and that its execution, delivery, and performance of this Amendment has been fully authorized and approved, and that no further approvals or consents are required to bind such party.
5. ELECTRONIC SIGNATURES. An electronic signature of this Amendment or any other ancillary agreement shall be deemed to have the same legal effect as delivery of an original executed copy of this Amendment or such other ancillary agreement for all purposes.
6. COUNTERPARTS. This Amendment may be executed in one or more counterparts, each of which shall be deemed an original, and all of which counterparts together shall constitute the same instrument which may be sufficiently evidenced by one counterpart. Execution of this Amendment at different times and places by the parties shall not affect the validity thereof so long as all the parties hereto execute a counterpart of this Amendment.

EXECUTED AND EFFECTIVE as of the day and date first above written.

**SALT DISTRIBUTORS, INC**  
**A WASHINGTON CORPORATION**

**STATE OF WASHINGTON**  
**DEPARTMENT OF ENTERPRISE SERVICES**

By: *Nic Binczewski*

By: Theresa Jensen Digitally signed by Theresa Jensen  
Date: 2023.10.10 12:32:51 -07'00'

Name: Nic Binczewski

Name: Theresa Jensen

Title: VP

Title: Procurement Supervisor

Date: 9-26-23

Date: 10/10/2023

**Category 4C**  
**Corrosion Inhibited Solid Sodium Chloride - Grade 2, Maximum Moisture Content 5% Standard**  
**Gradation**

Anti-Caking Agent:	Proprietary Blend of Additives
Product:	Ice Kicker
Drop Shipment:	\$75

**WSDOT Region 1 Northwest**

Order/Delivery Area	3 Days	7 Days	30 Days
Maintenance Area 1	\$228.72	\$221.29	\$215.99
Maintenance Area 2	\$229.98	\$222.56	\$217.25
Maintenance Area 3	\$226.91	\$219.49	\$214.19
Maintenance Area 4	\$208.53	\$201.10	\$195.80
Maintenance Area 5	\$214.66	\$207.23	\$201.93

**WSDOT Region 2 North Central**

Order/Delivery Area	3 Days	7 Days	30 Days
Maintenance Area 1	\$202.36	\$194.95	\$189.66
Maintenance Area 2	\$187.37	\$179.96	\$174.66
Maintenance Area 3	\$207.46	\$200.05	\$194.75

**WSDOT Region 3 Olympic**

Order/Delivery Area	3 Days	7 Days	30 Days
Maintenance Area 1	\$203.81	\$196.39	\$191.09
Maintenance Area 2	\$212.53	\$205.11	\$198.75
Maintenance Area 3	\$226.79	\$219.37	\$214.07
Maintenance Area 4	\$212.66	\$205.24	\$199.94

**WSDOT Region 4 Southwest**

Order/Delivery Area	3 Days	7 Days	30 Days
Maintenance Area 1	\$229.83	\$222.41	\$217.11
Maintenance Area 2	\$207.89	\$200.47	\$207.92
Maintenance Area 3	\$223.70	\$216.28	\$210.99
Maintenance Area 4	\$212.66	\$205.24	\$199.94

**WSDOT Region 5 South Central**

<b>Order/Delivery Area</b>	<b>3 Days</b>	<b>7 Days</b>	<b>30 Days</b>
Maintenance Area 1	\$211.44	\$204.02	\$198.73
Maintenance Area 2	\$207.89	\$200.47	\$195.18
Maintenance Area 3	\$190.61	\$183.19	\$177.89
Maintenance Area 4	\$193.95	\$186.53	\$181.23

**WSDOT Region 6 Eastern**

<b>Order/Delivery Area</b>	<b>3 Days</b>	<b>7 Days</b>	<b>30 Days</b>
Maintenance Area 1	\$185.12	\$177.71	\$172.41
Maintenance Area 2	\$185.82	\$178.41	\$173.11
Maintenance Area 3	\$186.47	\$179.05	\$173.76
Maintenance Area 4	\$192.49	\$185.08	\$179.78

**Category 8A-B  
Standard Gradation Brining Salt**

Anti-Caking Agent:	None
Product:	Drinox Extra Coarse
Drop Shipment:	\$75

**WSDOT Region 1 Northwest**

Order/Delivery Area	3 Days	7 Days	30 Days
Maintenance Area 1	\$232.39	\$225.01	\$219.74
Maintenance Area 2	\$239.78	\$232.39	\$225.01
Maintenance Area 3	\$236.59	\$229.21	\$223.93
Maintenance Area 4	\$218.30	\$210.92	\$205.64
Maintenance Area 5	\$224.40	\$217.01	\$211.74

**WSDOT Region 2 North Central**

Order/Delivery Area	3 Days	7 Days	30 Days
Maintenance Area 1	\$211.03	\$203.66	\$198.40
Maintenance Area 2	\$196.12	\$188.75	\$183.49
Maintenance Area 3	\$216.10	\$208.73	\$203.46

**WSDOT Region 3 Olympic**

Order/Delivery Area	3 Days	7 Days	30 Days
Maintenance Area 1	\$213.46	\$206.08	\$200.82
Maintenance Area 2	\$222.13	\$214.76	\$208.43
Maintenance Area 3	\$236.30	\$228.93	\$223.66
Maintenance Area 4	\$230.21	\$222.84	\$205.82

**WSDOT Region 4 Southwest**

Order/Delivery Area	3 Days	7 Days	30 Days
Maintenance Area 1	\$239.39	\$232.02	\$226.75
Maintenance Area 2	\$228.15	\$220.77	\$217.61
Maintenance Area 3	\$233.30	\$225.92	\$220.66
Maintenance Area 4	\$218.46	\$211.09	\$205.82

**WSDOT Region 5 South Central**

Order/Delivery Area	3 Days	7 Days	30 Days
Maintenance Area 1	\$216.13	\$208.76	\$206.65
Maintenance Area 2	\$211.09	\$203.71	\$198.44

Maintenance Area 3	\$211.61	\$204.24	\$198.97
Maintenance Area 4	\$198.74	\$191.36	\$189.25

**WSDOT Region 6 Eastern**

Order/Delivery Area	3 Days	7 Days	30 Days
Maintenance Area 1	\$187.83	\$180.46	\$175.20
Maintenance Area 2	\$188.52	\$181.16	\$175.89
Maintenance Area 3	\$189.17	\$181.80	\$176.53
Maintenance Area 4	\$195.16	\$187.79	\$182.52



**Category 8A-R  
Standard Gradation Road Salt**

Anti-Caking Agent:	none
Product:	Drinox Extra Coarse
Drop Shipment:	\$75

**WSDOT Region 1 Northwest**

Order/Delivery Area	3 Days	7 Days	30 Days
Maintenance Area 1	\$232.39	\$225.01	\$219.74
Maintenance Area 2	\$239.78	\$232.39	\$225.01
Maintenance Area 3	\$236.59	\$229.21	\$223.93
Maintenance Area 4	\$218.30	\$210.92	\$205.64
Maintenance Area 5	\$224.40	\$217.01	\$211.74

**WSDOT Region 2 North Central**

Order/Delivery Area	3 Days	7 Days	30 Days
Maintenance Area 1	\$211.03	\$203.66	\$198.40
Maintenance Area 2	\$196.12	\$188.75	\$183.49
Maintenance Area 3	\$216.10	\$208.73	\$203.46

**WSDOT Region 3 Olympic**

Order/Delivery Area	3 Days	7 Days	30 Days
Maintenance Area 1	\$213.46	\$206.08	\$200.82
Maintenance Area 2	\$222.13	\$214.76	\$208.43
Maintenance Area 3	\$236.30	\$228.93	\$223.66
Maintenance Area 4	\$230.21	\$222.84	\$217.57

**WSDOT Region 4 Southwest**

Order/Delivery Area	3 Days	7 Days	30 Days
Maintenance Area 1	\$239.39	\$232.02	\$226.75
Maintenance Area 2	\$228.15	\$220.77	\$217.61
Maintenance Area 3	\$233.30	\$225.92	\$220.66
Maintenance Area 4	\$218.46	\$211.09	\$205.82

**WSDOT Region 5 South Central**

Order/Delivery Area	3 Days	7 Days	30 Days
Maintenance Area 1	\$216.18	\$208.80	\$206.69
Maintenance Area 2	\$211.13	\$203.75	\$198.48

Maintenance Area 3	\$211.65	\$204.28	\$199.01
Maintenance Area 4	\$198.77	\$191.40	\$189.29

**WSDOT Region 6 Eastern**

Order/Delivery Area	3 Days	7 Days	30 Days
Maintenance Area 1	\$187.83	\$180.46	\$175.20
Maintenance Area 2	\$188.52	\$181.16	\$175.89
Maintenance Area 3	\$187.17	\$181.80	\$176.53
Maintenance Area 4	\$195.16	\$187.79	\$182.52

**Category 8B  
Solid Sodium Chloride**

Anti-Caking Agent:	YPS
Product:	Qwiksalt
Drop Shipment:	\$75

**WSDOT Region 1 Northwest**

Order/Delivery Area	3 Days	7 Days	30 Days
Maintenance Area 1	\$201.40	\$193.99	\$188.70
Maintenance Area 2	\$206.69	\$199.28	\$193.99
Maintenance Area 3	\$199.60	\$192.19	\$186.90
Maintenance Area 4	\$182.30	\$174.89	\$168.54
Maintenance Area 5	\$187.36	\$179.95	\$174.66

**WSDOT Region 2 North Central**

Order/Delivery Area	3 Days	7 Days	30 Days
Maintenance Area 1	\$173.53	\$166.13	\$160.85
Maintenance Area 2	\$163.85	\$156.45	\$151.16
Maintenance Area 3	\$178.62	\$171.22	\$165.93

**WSDOT Region 3 Olympic**

Order/Delivery Area	3 Days	7 Days	30 Days
Maintenance Area 1	\$176.52	\$166.11	\$163.82
Maintenance Area 2	\$184.16	\$176.76	\$171.47
Maintenance Area 3	\$199.45	\$192.04	\$186.75
Maintenance Area 4	\$193.33	\$185.93	\$180.64

**WSDOT Region 4 Southwest**

Order/Delivery Area	3 Days	7 Days	30 Days
Maintenance Area 1	\$202.47	\$195.06	\$189.78
Maintenance Area 2	\$193.30	\$185.89	\$180.61
Maintenance Area 3	\$196.35	\$188.95	\$183.66
Maintenance Area 4	\$189.06	\$181.65	\$176.37

**WSDOT Region 5 South Central**

Order/Delivery Area	3 Days	7 Days	30 Days
Maintenance Area 1	\$181.73	\$174.33	\$169.04
Maintenance Area 2	\$182.94	\$175.54	\$168.13

Maintenance Area 3	\$173.21	\$165.81	\$160.52
Maintenance Area 4	\$174.85	\$167.44	\$162.16

**WSDOT Region 6 Eastern**

Order/Delivery Area	3 Days	7 Days	30 Days
Maintenance Area 1	\$157.79	\$150.39	\$137.58
Maintenance Area 2	\$153.20	\$145.80	\$137.33
Maintenance Area 3	\$155.96	\$148.56	\$136.92
Maintenance Area 4	\$162.42	\$155.01	\$150.78

**Category 8C-R  
Fine Gradation Road Salt**

Anti-Caking Agent:	None
Product:	Medium Solar Salt
Drop Shipment:	\$75

**WSDOT Region 1 Northwest**

Order/Delivery Area	3 Days	7 Days	30 Days
Maintenance Area 1	\$220.30	\$213.30	\$208.30
Maintenance Area 2	\$227.30	\$220.30	\$213.30
Maintenance Area 3	\$224.28	\$217.28	\$212.28
Maintenance Area 4	\$206.94	\$199.94	\$194.94
Maintenance Area 5	\$212.72	\$205.72	\$200.72

**WSDOT Region 2 North Central**

Order/Delivery Area	3 Days	7 Days	30 Days
Maintenance Area 1	\$200.41	\$193.41	\$188.41
Maintenance Area 2	\$186.25	\$179.25	\$174.25
Maintenance Area 3	\$205.22	\$198.22	\$193.22

**WSDOT Region 3 Olympic**

Order/Delivery Area	3 Days	7 Days	30 Days
Maintenance Area 1	\$202.60	\$195.60	\$190.60
Maintenance Area 2	\$210.83	\$203.83	\$197.83
Maintenance Area 3	\$224.28	\$217.28	\$212.28
Maintenance Area 4	\$218.50	\$211.50	\$206.50

**WSDOT Region 4 Southwest**

Order/Delivery Area	3 Days	7 Days	30 Days
Maintenance Area 1	\$227.17	\$220.17	\$215.17
Maintenance Area 2	\$216.50	\$209.50	\$206.50
Maintenance Area 3	\$221.39	\$214.39	\$209.39
Maintenance Area 4	\$207.31	\$200.31	\$195.31

**WSDOT Region 5 South Central**

Order/Delivery Area	3 Days	7 Days	30 Days
Maintenance Area 1	205.1	198.1	196.1
Maintenance Area 2	200.31	193.31	188.31

Maintenance Area 3	200.81	193.81	188.81
Maintenance Area 4	188.59	181.59	179.59

**WSDOT Region 6 Eastern**

Order/Delivery Area	3 Days	7 Days	30 Days
Maintenance Area 1	\$178.41	\$171.41	\$166.41
Maintenance Area 2	\$179.07	\$172.07	\$167.07
Maintenance Area 3	\$179.68	\$172.68	\$167.68
Maintenance Area 4	\$185.37	\$178.37	\$173.37

**Category 8C-B  
Fine Gradation Brining Salt**

Anti-Caking Agent:	None
Product:	Medium Solar Salt
Drop Shipment:	\$75

**WSDOT Region 1 Northwest**

Order/Delivery Area	3 Days	7 Days	30 Days
Maintenance Area 1	\$220.30	\$213.30	\$208.30
Maintenance Area 2	\$227.30	\$220.30	\$213.30
Maintenance Area 3	\$224.28	\$217.28	\$212.28
Maintenance Area 4	\$206.94	\$199.94	\$194.94
Maintenance Area 5	\$212.72	\$205.72	\$200.72

**WSDOT Region 2 North Central**

Order/Delivery Area	3 Days	7 Days	30 Days
Maintenance Area 1	\$200.41	\$193.41	\$188.41
Maintenance Area 2	\$186.25	\$179.25	\$174.25
Maintenance Area 3	\$205.22	\$198.22	\$193.22

**WSDOT Region 3 Olympic**

Order/Delivery Area	3 Days	7 Days	30 Days
Maintenance Area 1	\$202.60	\$195.60	\$190.60
Maintenance Area 2	\$210.83	\$203.83	\$197.83
Maintenance Area 3	\$224.28	\$217.28	\$212.28
Maintenance Area 4	\$218.50	\$211.50	\$206.50

**WSDOT Region 4 Southwest**

Order/Delivery Area	3 Days	7 Days	30 Days
Maintenance Area 1	\$227.17	\$220.17	\$215.17
Maintenance Area 2	\$216.50	\$209.50	\$206.50
Maintenance Area 3	\$221.39	\$214.39	\$209.39
Maintenance Area 4	\$207.31	\$200.31	\$195.31

**WSDOT Region 5 South Central**

Order/Delivery Area	3 Days	7 Days	30 Days
Maintenance Area 1	205.1	198.1	196.1
Maintenance Area 2	200.31	193.31	188.31

Maintenance Area 3	200.81	193.81	188.81
Maintenance Area 4	188.59	181.59	179.59

**WSDOT Region 6 Eastern**

Order/Delivery Area	3 Days	7 Days	30 Days
Maintenance Area 1	\$178.41	\$171.41	\$166.41
Maintenance Area 2	\$179.07	\$172.07	\$167.07
Maintenance Area 3	\$179.68	\$172.68	\$167.68
Maintenance Area 4	\$185.37	\$178.37	\$173.37



State of Washington Contracts & Procurement Division Department of Enterprise Services P.O. Box 41411 Olympia, WA 98504-1411	<b>CONTRACT AMENDMENT</b>	
	Contract No.:	11021
Salt Distributors, Inc 15201 E Marietta Ave Spokane Valley, WA 99216	Amendment No.:	1
	Effective Date:	10-3-2022

**FIRST AMENDMENT  
TO  
STATEWIDE CONTRACT NO. 11021  
SNOW & ICE CONTROL PRODUCTS**

This First Amendment ("Amendment") to Contract No. 11021 is made and entered into by and between the State of Washington acting by and through the Department of Enterprise Services, a Washington State governmental agency ("State") and Salt Distributors, Inc., a Corporation ("Contractor") and is dated as of October 3rd, 2022.

**RECITALS**

- A. State and Contractor (collectively the "Parties") entered into that certain Contract No. 11021 for Snow and Ice Control Products dated effective as of August 1, 2022 ("Contract").
- B. The Parties have not previously amended the Contract.
- C. The amendment set forth herein is within the scope of the Contract.
- D. The Parties now desire to amend the Contract as set forth herein.

**AGREEMENT**

NOW THEREFORE, in consideration of the mutual covenants and agreements set forth herein, the Parties hereby agree to amend the Contract, as previously amended, as follows:

- 1. **TOPIC: 80/120 Target Commitments.** The parties agree that these are the original target commitments for the 2022/2023 winter maintenance season for WSDOT Regions and Political Subdivisions:

**WSDOT**

Category 4C: Corrosion Inhibited Solid Sodium Chloride-Grade 2						
Region	Customer	80%	Target (100%)	120%	Unit of Measure	Product
North Central	WSDOT	3,440	4,300	5,160	Tons	Ice Kicker
Eastern	WSDOT	7,760	9,700	11,640	Tons	Ice Kicker

Category 8A-R: Standard Gradation, Road Salt						
Region	Customer	80%	Target (100%)	120%	Unit of Measure	Product
North Central	WSDOT	180	225	270	Tons	DriRox & Quicksalt

Category 8B: Standard Gradation Road Salt, Insoluble Material						
Region	Customer	80%	Target (100%)	120%	Unit of Measure	Product
Eastern	WSDOT	4,240	5,300	6,360	Tons	Qwiksalt Type C

Political Subdivision commitments

Category 4C: Corrosion Inhibited Solid Sodium Chloride-Grade 2						
Region	Customer	80%	Target (100%)	120%	Unit of Measure	Product
Olympic	City of Puyallup	80	100	120	Tons	Ice Kicker
Northwest	City of Bellingham	640	800	960	Tons	Ice Kicker
Northwest	Snohomish County	320	400	480	Tons	Ice Kicker
North Central	City of Wenatchee	320	400	480	Tons	Ice Kicker

Category 8A-R: Standard Gradation, Road Salt						
Region	Customer	80%	Target (100%)	120%	Unit of Measure	Product
Olympic	City of Puyallup	80	100	120	Tons	Dri-Rox Extra Coarse Brine Salt
Northwest	City of Federal Way	144	180	216	Tons	Dri-Rox Extra Coarse Brine Salt

Category 8B: Solid Sodium Chloride						
Region	Customer	80%	Target (100%)	120%	Unit of Measure	Product
North Central	Chelan County	2,240	2,800	3,360	Tons	Qwiksalt Type C
Northwest	City of Mukilteo	80	100	120	Tons	Quicksalt Type C
Olympic	City of Lakewood	80	100	120	Tons	Qwiksalt Type C

2. NO CHANGE OTHER THAN AMENDMENT. Except as amended herein, the Contract is unaffected and remains in full force and effect.
3. INTEGRATED AGREEMENT; MODIFICATION. This Amendment constitutes the entire agreement and understanding of the Parties with respect to the subject matter and supersedes all prior negotiations and representations. In the event of any conflict between this Amendment and the

Contract or any earlier amendment, this Amendment shall control and govern. This Amendment may not be modified except in writing signed by the Parties.

4. AUTHORITY. Each party to this Amendment, and each individual signing on behalf of each party, hereby represents and warrants to the other that it has full power and authority to enter into this Amendment and that its execution, delivery, and performance of this Amendment has been fully authorized and approved, and that no further approvals or consents are required to bind such party.
5. ELECTRONIC SIGNATURES. An electronic signature or electronic record of this Amendment or any other ancillary agreement shall be deemed to have the same legal effect as delivery of an original executed copy of this Amendment or such other ancillary agreement for all purposes.
6. COUNTERPARTS. This Amendment may be executed in one or more counterparts, each of which shall be deemed an original, and all of which counterparts together shall constitute the same instrument which may be sufficiently evidenced by one counterpart. Execution of this Amendment at different times and places by the parties shall not affect the validity thereof so long as all the parties hereto execute a counterpart of this Amendment.

EXECUTED AND EFFECTIVE as of the day and date first above written.

SALT DISTRIBUTORS, INC  
A CORPORATION

STATE OF WASHINGTON  
DEPARTMENT OF ENTERPRISE SERVICES

By: 

By: 

Name: Nic Minczowski

Name: Alex Kenesson

Title: VP

Title: Procurement Supervisor

Date: 10-9-22

Date: 10/21/2022



## < Business Lookup

### License Information:

[New search](#) [Back to results](#)

**Entity name:** SALT DISTRIBUTORS, INC.

**Business name:** SALT DISTRIBUTORS, INC.

**Entity type:** [Profit Corporation](#)

**UBI #:** 602-332-257

**Business ID:** 001

**Location ID:** 0001

**Location:** Active

**Location address:** 15201 E MARRIETTA AVE  
SPOKANE VALLEY WA 99216

**Mailing address:** PO BOX 100  
NEWMAN LAKE WA 99025-0100



**Excise tax and reseller permit status:**

[Click here](#)

**Secretary of State status:**

[Click here](#)

## Endorsements

Endorsements held at this lo	License #	Count	Details	Status	Expiration da	First issuance
Liberty Lake General Business - Non-Resident				<a href="#">Active</a>	Oct-31-2024	Sep-29-2022
Spokane General Business - Non-Resident				Active	Oct-31-2024	Nov-13-2017
Spokane Valley General Business - Non-Resident				Active	Oct-31-2024	Nov-29-2017

## Governing People May include governing people not registered with Secretary of State

Governing people	Title
BINCZEWSKI, NIC	
BINCZEWSKI, STAN	

## Registered Trade Names

Registered trade names	Status		First issued
------------------------	--------	---	--------------

Registered trade names	Status	First issued
SALT DISTRIBUTORS, INC.	Active	Mar-10-2009

The Business Lookup information is updated nightly. Search date and time:  
10/14/2024 12:39:58 PM

**Contact us**

How are we doing?

**Take our survey!**

Don't see what you expected?

**Check if your browser is supported**





**Agenda Sheet for City Council:**

**Committee:** PIES **Date:** 10/21/2024

**Committee Agenda type:** Consent

**Date Rec'd**

10/22/2024

**Clerk's File #**

OPR 2024-0936

**Cross Ref #**

**Project #**

**Council Meeting Date:** 11/04/2024

**Submitting Dept**

STREETS

**Bid #**

**Contact Name/Phone**

CLINT HARRIS 625-7744

**Requisition #**

**Contact E-Mail**

CEHARRIS@SPOKANECITY.ORG

**Agenda Item Type**

Purchase w/o Contract

**Council Sponsor(s)**

BWILKERSON JBINGLE KKLITZKE

**Agenda Item Name**

1100 - STREETS ICE KICKER

**Agenda Wording**

The Street Department is seeking approval for the purchase of Ice Kicker at a cost not to exceed \$115,000.00

**Summary (Background)**

This salt-based product with anti-corrosive inhibitors added is used by the Streets Department during the winter months for deicing. Used primarily in the CBD area and is purchased off the State Contract #11021. Ice Kicker is purchased from Salt Distributors Inc.

Lease? NO Grant related? NO Public Works? NO

**Fiscal Impact**

Approved in Current Year Budget? YES

Total Cost \$ 115,000

Current Year Cost \$

Subsequent Year(s) Cost \$

**Narrative**

**Amount**

**Budget Account**

Expense \$ 115,000

# 1100-21800-42660-53210-99999

Select \$

#

Select \$

#

Select \$

#

\$

#

\$

#



## Continuation of Wording, Summary, Approvals, and Distribution

### Agenda Wording

### Summary (Background)

#### **Approvals**

##### Dept Head

HARRIS, CLINT E.

##### Division Director

FEIST, MARLENE

##### Accounting Manager

ORLOB, KIMBERLY

##### Legal

HARRINGTON,

##### For the Mayor

PICCOLO, MIKE

#### **Additional Approvals**

#### **Distribution List**

CEHARRIS@SPOKANECITY.ORG

JWTHOMAS@SPOKANECITY.ORG

KAIUMU@SPOKANECITY.ORG



## Committee Briefing Paper

### Public Infrastructure, Environment & Sustainability Committee

<b>Committee Date</b>	10/21/2024
<b>Submitting Department</b>	Streets
<b>Contact Name</b>	Clint Harris
<b>Contact Email &amp; Phone</b>	<a href="mailto:ceharris@spokanecity.org">ceharris@spokanecity.org</a> 625-7744
<b>Council Sponsor(s)</b>	Wilkerson, Bingle, Klitzke
<b>Select Agenda Item Type</b>	<input checked="" type="checkbox"/> Consent <input type="checkbox"/> Discussion    Time Requested:
<b>Agenda Item Name</b>	1100 – Streets Ice Kicker
<b>Proposed Council Action</b>	<input checked="" type="checkbox"/> Approval to proceed to Legislative Agenda <input type="checkbox"/> Information Only
<b>Summary (Background)</b>  *use the Fiscal Impact box below for relevant financial information	<p>The Street Department is seeking approval for the purchase of Ice Kicker at a cost not to exceed \$115,000.00</p> <p>This salt-based product with anticorrosive inhibitors added is used by the Streets Department during the winter months for deicing. Used primarily in the CBD area and is purchased off the State Contract #11021. Ice Kicker is purchased from Salt Distributors Inc.</p>
<p><b>Fiscal Impact</b></p> <p><b>Approved in current year budget?</b>    <input checked="" type="checkbox"/> Yes    <input type="checkbox"/> No    <input type="checkbox"/> N/A</p> <p>Total Cost: <u>115,000.00</u></p> <p>Current year cost:</p> <p>Subsequent year(s) cost:</p> <p><b>Narrative:</b> Please provide financial due diligence review, as applicable, such as number and type of positions, grant match requirements, summary type details (personnel, maintenance and supplies, capital, revenue), impact on rates, fees, or future shared revenue</p> <p><b>Funding Source</b>    <input type="checkbox"/> One-time    <input checked="" type="checkbox"/> Recurring    <input type="checkbox"/> N/A</p> <p>Specify funding source: Select Funding Source*</p> <p>Is this funding source sustainable for future years, months, etc? <a href="#">Click or tap here to enter text.</a></p> <p><b>Expense Occurrence</b>    <input type="checkbox"/> One-time    <input checked="" type="checkbox"/> Recurring    <input type="checkbox"/> N/A</p> <p>Other budget impacts: (revenue generating, match requirements, etc.)</p>	
<p><b>Operations Impacts</b> (If N/A, please give a brief description as to why)</p> <ul style="list-style-type: none"> <li>• What impacts would the proposal have on historically excluded communities? <u>N/A, material will be used to maintain roadways across the city.</u></li> <li>• How will data be collected, analyzed, and reported concerning the effect of the program/policy by racial, ethnic, gender identity, national origin, income level, disability, sexual orientation, or other existing disparities? <u>N/A, material will be used to maintain roadways across the city.</u></li> </ul>	

- How will data be collected regarding the effectiveness of this program, policy, or product to ensure it is the right solution?

N/A, material will be used to maintain roadways across the city.

- Describe how this proposal aligns with current City Policies, including the Comprehensive Plan, Sustainability Action Plan, Capital Improvement Program, Neighborhood Master Plans, Council Resolutions, and others?

N/A, material will be used to maintain roadways across the city.

### **Council Subcommittee Review**

- Please provide a summary of council subcommittee review. If not reviewed by a council subcommittee, please explain why not.

Subcommittee review not necessary.

DES Statewide Contract No. 11021 - Snow & Ice Control Products				
Inhibited Road Salts				
	<b>Category 4C Corrosion Inhibited Solid Sodium Chloride- Grade 2 Max. Moisture Content 5% Standard Gradation (80/120 eligible product)</b>			
	CONTRACTOR(S)			
	<b>Salt Distributors (SDI)</b> Nic Binczewski #509-218-1983 <a href="mailto:sales@salt distributorsinc.com">sales@salt distributorsinc.com</a> Yes, Small Business			
	Ordering Contact Ordering E-Mail Small Business Concentration Product Drop Shipment	Concentration Product Drop Shipment	Proprietary Blend of Additives Ice Kicker \$75.00	
REGION		3 DAY PRICE	7 DAY PRICE	30 DAY PRICE
Region 1 Northwest	Maintenance Area 1	\$228.72	\$221.29	\$215.99
	Maintenance Area 2	\$229.98	\$222.56	\$217.25
	Maintenance Area 3	\$226.91	\$219.49	\$214.19
	Maintenance Area 4	\$208.53	\$201.10	\$195.80
	Maintenance Area 5	\$214.66	\$207.23	\$201.93
Region 2 North Central	Maintenance Area 1	\$202.36	\$194.95	\$189.66
	Maintenance Area 2	\$187.37	\$179.96	\$174.66
	Maintenance Area 3	\$207.46	\$200.05	\$194.75
Region 3 Olympic	Maintenance Area 1	\$203.81	\$196.39	\$191.09
	Maintenance Area 2	\$212.53	\$205.11	\$198.75
	Maintenance Area 3	\$226.79	\$219.37	\$214.07
	Maintenance Area 4	\$212.66	\$205.24	\$199.94
Region 4 SouthWest	Maintenance Area 1	\$229.83	\$222.41	\$211.11
	Maintenance Area 2	\$207.89	\$200.47	\$201.92
	Maintenance Area 3	\$223.70	\$216.28	\$204.99
	Maintenance Area 4	\$212.66	\$205.24	\$193.94
Region 5 South Central	Maintenance Area 1	\$211.44	\$204.02	\$192.73
	Maintenance Area 2	\$207.89	\$200.47	\$189.18
	Maintenance Area 3	\$190.61	\$183.19	\$171.89
	Maintenance Area 4	\$193.95	\$186.53	\$175.23
Region 6 Eastern	Maintenance Area 1	\$185.12	\$177.71	\$172.41
	Maintenance Area 2	\$185.82	\$178.41	\$173.11
	Maintenance Area 3	\$186.47	\$179.05	\$173.76
	Maintenance Area 4	\$192.49	\$185.08	\$179.78

Pricing Eff. 08/01/2024

DES Statewide Contract No. 11021 - Snow & Ice Control					
Brine Salt					
		<b>Category 8A-B Standard Gradation Brining Salt</b>			
		CONTRACTOR(S)			
		<b>Salt Distributors (SDI)</b>			
		Ordering Contact	Mic Binczewski #509-218-198		
		Ordering E-Mail	<a href="mailto:sales@salt distributorsinc.com">sales@salt distributorsinc.com</a>		
Small Business	Yes, Small Business				
Anti-Caking Agent	None				
Product	Drirox Extra Coarse				
Drop Shipment	\$75.00				
REGION		3 DAY PRICE	7 DAY PRICE	30 DAY PRICE	
Region 1 Northwest	Maintenance Area 1	\$232.39	\$225.01	\$219.74	
	Maintenance Area 2	\$239.78	\$232.39	\$225.01	
	Maintenance Area 3	\$236.59	\$229.21	\$223.93	
	Maintenance Area 4	\$218.30	\$210.92	\$205.64	
	Maintenance Area 5	\$224.40	\$217.01	\$211.74	
Region 2 North Central	Maintenance Area 1	\$211.03	\$203.66	\$198.40	
	Maintenance Area 2	\$196.12	\$188.75	\$183.49	
	Maintenance Area 3	\$216.10	\$208.73	\$203.46	
Region 3 Olympic	Maintenance Area 1	\$213.46	\$206.08	\$200.82	
	Maintenance Area 2	\$222.13	\$214.76	\$208.43	
	Maintenance Area 3	\$236.30	\$228.93	\$223.66	
	Maintenance Area 4	\$230.21	\$222.84	\$205.82	
Region 4 SouthWest	Maintenance Area 1	\$239.39	\$232.02	\$226.75	
	Maintenance Area 2	\$228.15	\$220.77	\$217.61	
	Maintenance Area 3	\$233.30	\$225.92	\$220.66	
	Maintenance Area 4	\$218.46	\$211.09	\$205.82	
Region 5 South Central	Maintenance Area 1	\$216.13	\$208.76	\$206.65	
	Maintenance Area 2	\$211.09	\$203.71	\$198.44	
	Maintenance Area 3	\$211.61	\$204.24	\$198.97	
	Maintenance Area 4	\$198.74	\$191.36	\$189.25	
Region 6 Eastern	Maintenance Area 1	\$187.83	\$180.46	\$175.20	
	Maintenance Area 2	\$188.52	\$181.16	\$175.89	
	Maintenance Area 3	\$189.17	\$181.80	\$176.53	
	Maintenance Area 4	\$195.16	\$187.79	\$182.52	

**Agenda Sheet for City Council:****Committee:** PIES **Date:** 10/21/2024**Committee Agenda type:** Consent**Date Rec'd**

10/22/2024

**Clerk's File #**

OPR 2024-0937

**Cross Ref #****Project #****Council Meeting Date:** 11/04/2024**Submitting Dept**

STREETS

**Bid #**

WA STATE

**Contact Name/Phone**

CLINT HARRIS 625-7744

**Requisition #**

CR 26791

**Contact E-Mail**

CEHARRIS@SPOKANECITY.ORG

**Agenda Item Type**

Contract Item

**Council Sponsor(s)**

BWILKERSON JBINGLE KKLITZKE

**Agenda Item Name**

1100 – AUSTIN ROAD ASBESTOS ABATEMENT

**Agenda Wording**

The Street Department is seeking approval for the purchase of asbestos abatement services at a cost not to exceed \$80,476.00 plus applicable sales tax.

**Summary (Background)**

An illegal dumping of material containing asbestos has necessitated the need for an emergency cleanup of an area along Austin Road. The current contract between the City and NRC Environmental/Republic Services (OPR 2023-0397) does not support cost to abate the necessary area located on Austin Road. The proposal from NRC Environmental/Republic Services is written under the current Washington State Contract Department of Enterprise Services (DES) #09321.

Lease? NO Grant related? NO Public Works? YES

**Fiscal Impact**

Approved in Current Year Budget? NO

Total Cost \$ 80,476.00

Current Year Cost \$ 80,476.00

Subsequent Year(s) Cost \$ N/A

**Narrative**

Using Washington State Contract DES #09321

**Amount****Budget Account**

Expense \$ 80,476.00

# 1100-21700-42300-54201-99999

Select \$

#

Select \$

#

Select \$

#

\$

#

\$

#



**Continuation of Wording, Summary, Approvals, and Distribution**

**Agenda Wording**

**Summary (Background)**

**Approvals**

<b><u>Dept Head</u></b>	HARRIS, CLINT E.
<b><u>Division Director</u></b>	FEIST, MARLENE
<b><u>Accounting Manager</u></b>	ORLOB, KIMBERLY
<b><u>Legal</u></b>	SCHOEDEL, ELIZABETH
<b><u>For the Mayor</u></b>	JONES, GARRETT

**Additional Approvals**

<b><u>STREETS</u></b>	HARRIS, CLINT E.
<b><u>PURCHASING</u></b>	PRINCE, THEA

**Distribution List**

MARC GEMMELL	CEHARRIS@SPOKANECITY.ORG
JWTHOMAS@SPOKANECITY.ORG	KAIUMU@SPOKANECITY.ORG
tbrazington@spokanecity.org	

## Committee Briefing Paper

### Public Infrastructure, Environment & Sustainability Committee

<b>Committee Date</b>	10/21/2024
<b>Submitting Department</b>	Streets
<b>Contact Name</b>	Clint Harris
<b>Contact Email &amp; Phone</b>	<a href="mailto:charris@spokanecity.org">charris@spokanecity.org</a> 625-7744
<b>Council Sponsor(s)</b>	Wilkerson, Bingle, Klitzke
<b>Select Agenda Item Type</b>	<input checked="" type="checkbox"/> Consent <input type="checkbox"/> Discussion    Time Requested:
<b>Agenda Item Name</b>	1100 – Austin Road Asbestos Abatement
<b>Proposed Council Action</b>	<input checked="" type="checkbox"/> Approval to proceed to Legislative Agenda <input type="checkbox"/> Information Only
<b>Summary (Background)</b>	
<p>*use the Fiscal Impact box below for relevant financial information</p>	<p>An illegal dumping of material containing asbestos has necessitated the need for an emergency cleanup of an area along Austin Road. The request is to create a contract using Washington State Contract DES#09321.</p>
<p><b>Fiscal Impact</b></p> <p><b>Approved in current year budget?</b>    <input type="checkbox"/> Yes    <input checked="" type="checkbox"/> No    <input type="checkbox"/> N/A</p> <p>Total Cost: <u>\$80,476.00</u></p> <p>    Current year cost:</p> <p>    Subsequent year(s) cost:</p> <p><b>Narrative:</b> To note for funding source- possible funding from other departments.</p> <p><b>Funding Source</b>    <input checked="" type="checkbox"/> One-time    <input type="checkbox"/> Recurring    <input type="checkbox"/> N/A</p> <p>Specify funding source: Reallocation</p> <p>Is this funding source sustainable for future years, months, etc? <a href="#">Click or tap here to enter text.</a></p> <p><b>Expense Occurrence</b>    <input checked="" type="checkbox"/> One-time    <input type="checkbox"/> Recurring    <input type="checkbox"/> N/A</p> <p>Other budget impacts: (revenue generating, match requirements, etc.)</p>	
<p><b>Operations Impacts</b> (If N/A, please give a brief description as to why)</p> <ul style="list-style-type: none"> <li>• What impacts would the proposal have on historically excluded communities? <u>N/A, work is remedial to clean up the hazardous material and is not partial to any community.</u></li> <li>• How will data be collected, analyzed, and reported concerning the effect of the program/policy by racial, ethnic, gender identity, national origin, income level, disability, sexual orientation, or other existing disparities? <u>N/A, work is remedial to clean up the hazardous material and is not partial to any community.</u></li> </ul>	

- How will data be collected regarding the effectiveness of this program, policy, or product to ensure it is the right solution?

This contractor was chosen initially by the City as they are a qualified abatement contractor. The abatement will be done according to their policies and procedures. Data will be reported as required by federal and state regulations.

- Describe how this proposal aligns with current City Policies, including the Comprehensive Plan, Sustainability Action Plan, Capital Improvement Program, Neighborhood Master Plans, Council Resolutions, and others?

The work done will be cleaning up hazardous material

### **Council Subcommittee Review**

- Please provide a summary of council subcommittee review. If not reviewed by a council subcommittee, please explain why not.

Subcommittee review not necessary.





**City of Spokane**  
**PUBLIC WORKS CONTRACT**  
**REMOVAL OF HAZARDOUS MATERIALS**

This Agreement is made and entered into by and between the **CITY OF SPOKANE** as (“City”), a Washington municipal corporation, and **NRC ENVIRONMENTAL SERVICES, INC.**, whose address is 9520 10<sup>th</sup> Avenue South, Suite 150, Seattle, Washington 98101 as (“Contractor”), individually hereafter referenced as a “Party”, and together as the “Parties”.

*WHEREAS, the purpose of this Agreement is to provide as-needed Removal of Hazardous Materials for various City of Spokane locations; and*

*WHEREAS, the Contractor was selected from Washington State Department of Enterprise Services Contract #09321.*

*NOW, THEREFORE, in consideration of the terms, conditions, covenants and performance of the Scope of Work contained herein, the City and Contractor mutually agree as follows:*

**1. TERM OF AGREEMENT.**

The term of this Agreement begins on September 30, 2024, and ends on December 31, 2024, unless amended by written agreement or terminated earlier under the provisions

**2. TIME OF BEGINNING AND COMPLETION.**

The Contractor shall begin the work outlined in the “Scope of Work” (“Work”) on the beginning date, above. The City will acknowledge in writing when the Work is complete. Time limits established under this Agreement shall not be extended because of delays for which the Contractor is responsible, but may be extended by the City, in writing, for the City’s convenience or conditions beyond the Contractor’s control.

**3. SCOPE OF WORK.**

The Contractor’s General Scope of Work for this Agreement is described in WSDDES Contract No. 09321, Emergency Response to Hazardous Material, as well as Contractor’s Proposal dated September 16, 2024, which is attached as Exhibit B and made a part of this Agreement. In the event of a conflict or discrepancy in the Agreement documents, this City Agreement controls.

The Work is subject to City review and approval. The Contractor shall confer with the City periodically, and prepare and present information and materials (e.g. detailed outline of completed Work) requested by the City to determine the adequacy of the Work or Contractor’s progress.

#### **4. COMPENSATION / PAYMENT.**

Total compensation for Contractor's services under this Agreement shall be a maximum amount not to exceed **EIGHTY THOUSAND FOUR HUNDRED SEVENTY-SIX AND NO/100 DOLLARS (\$80,476.00)**, plus tax if applicable, unless modified by a written amendment to this Agreement. This is the maximum amount to be paid under this Agreement for the work described in Section 3 above, and shall not be exceeded without the prior written authorization of the City in the form of an executed amendment to this Agreement.

The Company shall submit its applications for payment to the Streets Department, Administration Office, 901 North Nelson Street, Spokane, Washington 99202. All invoices should include the City Clerk's File No. "OPR XXXX-XXXX" and an approved L & I Intent to Pay Prevailing Wage number. The final invoice should include an approved Affidavit of Wages Paid number. Payment will not be made without this documentation included on the invoice. **Payment will be made via direct deposit/ACH** within thirty (30) days after receipt of the Company's application except as provided by state law. If the City objects to all or any portion of the invoice, it shall notify the Company and reserves the right to only pay that portion of the invoice not in dispute. In that event, the parties shall immediately make every effort to settle the disputed amount.

#### **5. TAXES, FEES AND LICENSES.**

- A. Contractor shall pay and maintain in current status, all necessary licenses, fees, assessments, permit charges, etc. necessary to conduct the work included under this Agreement. It is the Contractor's sole responsibility to monitor and determine changes or the enactment of any subsequent requirements for said fees, assessments, or changes and to immediately comply.
- B. The cost of any permits, licenses, fees, etc. arising as a result of the projects included in this Agreement shall be included in the project budgets.

#### **6. STATEMENT OF INTENT TO PAY PREVAILING WAGES TO BE POSTED.**

The Contractor and each subcontractor required to pay the prevailing rate of wages shall post in a location readily visible at the job site: (1) a copy of a "Statement of Intent to Pay Prevailing Wages" approved by the industrial statistician of the Washington State Department of Labor and Industries (L & I); and (2) the address and telephone number of the industrial statistician of the Department of Labor and Industries where a complaint or inquiry concerning prevailing wages may be made.

#### **7. STATE PREVAILING WAGES.**

The Contractor and all subcontractors will submit a "Statement of Intent to Pay Prevailing Wages" certified by the industrial statistician of the Department of Labor and Industries, prior to any payments. The "Statement of Intent to Pay Prevailing Wages" shall include: (1) the Contractor's registration number; and (2) the prevailing wages under RCW 39.12.020 and the number of workers in each classification. Each voucher claim submitted by the Contractor for payment on a project estimate shall state that the prevailing wages have been paid in accordance with the "Statement(s) of Intent to Pay Prevailing Wages" on file with the City. Prior to the payment of funds held under RCW 60.28, the Contractor and subcontractors must submit an "Affidavit of Wages Paid" certified by the industrial statistician.

#### **8. RETAINAGE IN LIEU OF BOND.**

The Contractor may not commence work until it obtains all insurance, permits and bonds required by the contract documents and applicable law. In lieu of a one hundred percent (100%) payment/performance bond, in accord with RCW 39.08.010, the City shall retain ten percent

(10%) of the contract sum for thirty (30) days after date of final acceptance or until receipt of required releases and settlement of any liens filed under Chapter 60.28 RCW, whichever is later.

#### **9. PUBLIC WORKS REQUIREMENTS.**

The Contractor and each subcontractor are required to fulfill the Department of Labor and Industries Public Works and Prevailing Wage Training Requirement under RCW 39.04.350. The contractor must verify responsibility criteria for each first tier subcontractor, and a subcontractor of any tier that hires other subcontractors must verify the responsibility criteria listed in RCW 39.04.350(1) for each of its subcontractors. Verification shall include that each subcontractor, at the time of subcontract execution, meets the responsibility criteria. This verification requirement, as well as responsibility criteria, must be included in every public works contract and subcontract of every tier.

#### **10. CITY OF SPOKANE BUSINESS LICENSE.**

Section 8.01.070 of the Spokane Municipal Code states that no person may engage in business with the City without first having obtained a valid annual business registration. The Contractor shall be responsible for contacting the State of Washington Business License Services at [www.dor.wa.gov](http://www.dor.wa.gov) or 360-705-6741 to obtain a business registration. If the Contractor does not believe it is required to obtain a business registration, it may contact the City's Taxes and Licenses Division at (509) 625-6070 to request an exemption status determination.

#### **11. SOCIAL EQUITY REQUIREMENTS / NON-DISCRIMINATION.**

No individual shall be excluded from participation in, denied the benefit of, subjected to discrimination under, or denied employment in the administration of or in connection with this Agreement because of age, sex, race, color, religion, creed, marital status, familial status, sexual orientation including gender expression or gender identity, national origin, honorably discharged veteran or military status, the presence of any sensory, mental or physical disability, or use of a service animal by a person with disabilities. The Contractor agrees to comply with, and to require that all subcontractors comply with, federal, state and local nondiscrimination laws, including but not limited to: the Civil Rights Act of 1964, the Rehabilitation Act of 1973, the Age Discrimination in Employment Act, and the American's With Disabilities Act, to the extent those laws are applicable.

#### **12. INDEMNIFICATION.**

The Contractor shall defend, indemnify, and hold the City and its officers and employees harmless from all claims, demands, or suits at law or equity-asserted by third parties for bodily injury (including death) and/or property damage which arise from the Contractor's negligence or willful misconduct under this Agreement, including attorneys' fees and litigation costs; provided that nothing herein shall require a Contractor to indemnify the City against and hold harmless the City from claims, demands or suits based solely upon the negligence of the City, its agents, officers, and employees. If a claim or suit is caused by or results from the concurrent negligence of the Contractor's agents or employees and the City, its agents, officers and employees, this indemnity provision shall be valid and enforceable to the extent of the negligence of the Contractor, its agents or employees. The Contractor specifically assumes liability and agrees to defend, indemnify, and hold the City harmless for actions brought by the Contractor's own employees against the City and, solely for the purpose of this indemnification and defense, the Contractor specifically waives any immunity under the Washington State industrial insurance law, or Title 51 RCW. The Contractor recognizes that this waiver was specifically entered into pursuant to the provisions of RCW 4.24.115 and was the subject of mutual negotiation. The indemnity and

agreement to defend and hold the City harmless provided for in this section shall survive any termination or expiration of this agreement.

### **13. INSURANCE.**

During the period of the Agreement, the Contractor shall maintain in force at its own expense, each insurance noted below with companies or through sources approved by the State Insurance Commissioner pursuant to Title 48 RCW:

A. **Worker's Compensation Insurance** in compliance with RCW 51.12.020, which requires subject employers to provide workers' compensation coverage for all their subject workers and Employer's Liability Insurance in the amount of \$1,000,000;

B. **General Liability Insurance** on an occurrence basis, with a combined single limit of not less than \$1,000,000 each occurrence for bodily injury and property damage. It shall include contractual liability coverage for the indemnity provided under this agreement. It shall provide that the City, its officers and employees are additional insureds but only with respect to the Contractor's services to be provided under this Agreement;

- i. Acceptable supplementary Umbrella coverage in combination with Commercial General Liability policy shall be a minimum of \$2M in order to meet the minimum insurance coverages required under this contract;

C. **Automobile Liability Insurance** with a combined single limit, or the equivalent of not less than \$1,000,000 each accident for bodily injury and property damage, including coverage for owned, hired and non-owned vehicles; and

D. **Property Insurance** if materials and supplies are furnished by the Contractor. The amount of the insurance coverage shall be the value of the materials and supplies of the completed value of improvement. Hazard or XCU (explosion, collapse, underground) insurance should be provided if any hazard exists.

There shall be no cancellation, material change, or intent not to renew the insurance coverage(s) without thirty (30) days written notice from the Contractor or its insurer(s) or insurers authorized representative to the City. As evidence of the insurance coverages required by this Agreement, the Contractor shall furnish ACORD form insurance certificates to the City at the time it returns the signed Agreement. The certificate shall specify all of the parties who are additional insureds to the extent of Company's indemnify obligations, and include applicable blanket-form policy endorsements, including the blanket-form notice of cancellation endorsements (30days The Contractor shall be financially responsible for all pertinent deductibles, self-insured retentions, and/or self-insurance.

### **14. SUBCONTRACTOR RESPONSIBILITY.**

The Contractor must verify responsibility criteria for each first-tier subcontractor, and a subcontractor of any tier that hires other subcontractors must verify responsibility criteria for each of its subcontractors. Verification shall include that each subcontractor, at the time of subcontract execution, meets the responsibility criteria listed in RCW 39.04.350(1) and possesses an electrical contractor license, if required by chapter 19.28 RCW, or an elevator contractor license, if required by chapter 70.87 RCW.

#### **15. INDEPENDENT CONTRACTOR.**

The Contractor is an independent Contractor. This Agreement does not intend the Contractor to act as a City employee. The City has neither direct nor immediate control over the Contractor nor the right to control the manner or means by which the Contractor works. Neither the Contractor nor any Contractor employee shall be an employee of the City. This Agreement prohibits the Contractor to act as an agent or legal representative of the City. The Contractor is not granted express or implied rights or authority to assume or create any obligation or responsibility for or in the name of the City, or to bind the City. The City is not liable for or obligated to pay sick leave, vacation pay, or any other benefit of employment, nor to pay social security or other tax that may arise from employment. The Contractor shall pay all income and other taxes as due.

#### **16. ASSIGNMENT AND SUBCONTRACTING.**

The Contractor shall not assign or subcontract its obligations under this Agreement without the City's written consent, which may be granted or withheld in the City's sole discretion. Any subcontract made by the Contractor shall incorporate by reference this Agreement, except as otherwise provided. The Contractor shall ensure that all subcontractors comply with the obligations and requirements of the subcontract. The City's consent to any assignment or subcontract does not release the Contractor from liability or any obligation within this Agreement, whether before or after City consent, assignment or subcontract.

#### **17. TERMINATION.**

Either party may terminate this Agreement, with or without cause, by ten (10) days written notice to the other party. In the event of such termination, the City shall pay the Contractor for all work previously authorized and performed prior to the termination date.

#### **18. STANDARD OF PERFORMANCE.**

The standard of performance applicable to Contractor's services will be the degree of skill and diligence normally employed by professional contractors in the region performing the same or similar Contracting services at the time the work under this Agreement are performed.

#### **19. ANTI KICK-BACK.**

No officer or employee of the City of Spokane, having the power or duty to perform an official act or action related to this Agreement shall have or acquire any interest in the Agreement, or have solicited, accepted or granted a present or future gift, favor, service or other thing of value from or to any person involved in this Agreement.

#### **20. CONSTRUAL.**

The Contractor acknowledges receipt of a copy of the Agreement documents and agrees to comply with them. The silence or omission in the Agreement documents concerning any detail required for the proper execution and completion of the work means that only the best general practice is to prevail and that only material and workmanship of the best quality are to be used. This Contract shall be construed neither in favor of nor against either party.

#### **21. DEBARMENT AND SUSPENSION.**

The Contractor has provided its certification that it is in compliance with and shall not contract with individuals or organizations which are debarred, suspended, or otherwise excluded from or ineligible from participation in Federal Assistance Programs under Executive Order 12549 and "Debarment and Suspension", codified at 29 CFR part 98.

## **22. CONTRACTOR'S ACKNOWLEDGEMENT AND WARRANTY.**

The Contractor acknowledges that it has visited the site of the work, has examined it, and is qualified to perform the work required by this Agreement.

The Contractor guarantees and warranties all work, labor and materials under this Agreement for two (2) years following final acceptance. If any unsatisfactory condition or defect develops within that time, the Contractor will immediately place the work in a condition satisfactory to the City and repair all damage caused by the condition or defect. The Contractor will repair or restore to the City's satisfaction, in accordance with the contract documents and at its expense, all property damaged by his performance under this Agreement. This warranty is in addition to any manufacturers' or other warranty in the Agreement documents.

## **23. REMEDIES.**

In the event of a breach by either party, of any of their obligations under this Agreement, each party, in addition to being entitled to exercise all rights granted by law and under this Agreement, including recovery of damages, will be entitled to seek specific performance of its rights under this Agreement. The parties agree that monetary damages would not provide adequate compensation for any losses incurred by reason of a breach of any of the provisions of this Agreement and hereby further agree that, in the event of any action for specific performance in respect of such breach, it shall waive the defense that a remedy at law would be adequate.

## **24. MISCELLANEOUS PROVISIONS.**

- A. **Amendments/Modifications:** The City may modify this Agreement and order changes in the work whenever necessary or advisable. The Contractor may accept modifications when ordered in writing by the City, and the Agreement time and compensation will be adjusted accordingly.
- B. The Contractor, at no expense to the City, shall comply with all laws of the United States and Washington, the Charter and ordinances of the City of Spokane; and rules, regulations, orders and directives of their administrative agencies and officers.
- C. This Agreement shall be construed and interpreted under the laws of Washington. The venue of any action brought shall be in a court of competent jurisdiction, located in Spokane County, Washington.
- D. **Captions:** The titles of sections or subsections are for convenience only and do not define or limit the contents.
- E. **Severability:** If any term or provision is determined by a court of competent jurisdiction to be invalid or unenforceable, the remainder of this Agreement shall not be affected, and each term and provision shall be valid and enforceable to the fullest extent permitted by law.
- F. **Waiver:** No covenant, term or condition or the breach shall be deemed waived, except by written consent of the party against whom the waiver is claimed, and any waiver of the breach of any covenant, term or condition shall not be deemed a waiver of any preceding or succeeding breach of the same or any other covenant, term of condition. Neither the acceptance by the City of any performance by the Contractor after the time the same shall have become due nor payment to the Contractor for any portion of the Work shall constitute a waiver by the City of the breach or default of any covenant, term or condition unless otherwise expressly agreed to by the City in writing.
- G. **Entire Agreement:** This document along with any exhibits and all attachments, and subsequently issued addenda, comprises the entire agreement between the City and the Contractor. If conflict occurs between Agreement documents and applicable laws, codes,

ordinances or regulations, the most stringent or legally binding requirement shall govern and be considered a part of this Agreement to afford the City the maximum benefits.

- H. **No personal liability:** No officer, agent or authorized employee of the City shall be personally responsible for any liability arising under this Agreement, whether expressed or implied, nor for any statement or representation made or in any connection with this Agreement.
- I. Under Washington State Law (reference RCW Chapter 42.56, the *Public Records Act* [PRA]) all materials received or created by the City of Spokane are **public records** and are available to the public for viewing via the City Clerk's Records (online) or a valid Public Records Request (PRR).

IN WITNESS WHEREOF, in consideration of the terms, conditions and covenants contained, or attached and incorporated and made a part, the parties have executed this Agreement by having legally-binding representatives affix their signatures below.

**NRC ENVIRONMENTAL SERVICES, INC.**

**CITY OF SPOKANE**

By \_\_\_\_\_  
Signature Date

By \_\_\_\_\_  
Signature Date

\_\_\_\_\_  
Type or Print Name

\_\_\_\_\_  
Type or Print Name

\_\_\_\_\_  
Title

\_\_\_\_\_  
Title

Attest:

Approved as to form:

\_\_\_\_\_  
City Clerk

\_\_\_\_\_  
Assistant City Attorney

**Attachments that are part of this Agreement:**

Exhibit A – Debarment Certification

Exhibit B - Contractor's Proposal dated September 16, 2024

**EXHIBIT A**

**CERTIFICATION REGARDING DEBARMENT, SUSPENSION,  
INELIGIBILITY AND VOLUNTARY EXCLUSION**

1. The undersigned (i.e., signatory for the Subrecipient / Contractor / Consultant) certifies, to the best of its knowledge and belief, that it and its principals:
  - a. Are not presently debarred, suspended, proposed for debarment, declared ineligible, or voluntarily excluded from covered transactions by any federal department or agency;
  - b. Have not within a three-year period preceding this contract been convicted or had a civil judgment rendered against them for commission of fraud or a criminal offense in connection with obtaining, attempting to obtain, or performing a public (federal, state, or local) transaction or contract under a public transaction; violation of federal or state antitrust statutes or commission of embezzlement, theft, forgery, bribery, falsification or destruction of records, making false statements, tax evasion, receiving stolen property, making false claims, or obstruction of justice;
  - c. Are not presently indicted or otherwise criminally or civilly charged by a government entity (federal, state, or local) with commission of any of the offenses enumerated in paragraph (1)(b) of this certification; and,
  - d. Have not within a three-year period preceding this contract had one or more public transactions (federal, state, or local) terminated for cause or default.
2. The undersigned agrees by signing this contract that it shall not knowingly enter into any lower tier covered transaction with a person who is debarred, suspended, declared ineligible, or voluntarily excluded from participation in this covered transaction.
3. The undersigned further agrees by signing this contract that it will include the following clause, without modification, in all lower tier covered transactions and in all solicitations for lower tier covered transactions:

Certification Regarding Debarment, Suspension, Ineligibility and Voluntary Exclusion – Lower Tier Covered Transactions

1. The lower tier contractor certified, by signing this contract that neither it nor its principals is presently debarred, suspended, proposed for debarment, declared ineligible, or voluntarily excluded from participation in this transaction by any federal department or agency.
  2. Where the lower tier contractor is unable to certify to any of the statements in this contract, such contractor shall attach an explanation to this contract.
4. I understand that a false statement of this certification may be grounds for termination of the contract.

<hr/> <p>Name of Subrecipient / Contractor / Consultant (Type or Print)</p>	<hr/> <p>Program Title (Type or Print)</p>
<hr/> <p>Name of Certifying Official (Type or Print)</p>	<hr/> <p>Signature</p>
<hr/> <p>Title of Certifying Official (Type or Print)</p>	<hr/> <p>Date (Type or Print)</p>



**EXHIBIT B**



Sustainability in Action

September 16, 2024

Clint Harris  
City of Spokane  
Spokane WA. 99212

RE: City of Spokane – Asbestos Removal & Disposal – N. Austin Rd-between W. Strong Rd. & W. Walker Ave.  
Spokane WA.

Dear: Clint

NRC Environmental Services, Inc., a Republic Services company, (hereinafter referred to as “Republic”), is a global leader in providing environmental, industrial and emergency response solutions. Republic prides itself on project consistency and its logistics expertise in environmental remediation, abatement services, emergency response, environmental construction, hazardous waste management and industrial cleaning.

Pursuant to your request, Republic is pleased to present this estimate to City of Spokane . A brief Scope of Work precedes the proposal. Our goal with the SOW is to describe the resources, methods and process we will use to execute the SOW as they pertain to the information you provided.

## Scope of Work

Republic will provide labor, equipment, and disposal to complete the following services:

- Work with client to properly designate and profile waste for disposal.
- Prepare site specific safety plan for project including work and safety plan for **City of Spokane, N. Austin Rd. between Strong Rd. & W. Walker Ave. Spokane WA.**
- Republic Services will provide an Asbestos trained Contractor team to set up a regulated area with attached decontamination area to remove and dispose of approx. 16,000 Sq Ft. of Asbestos contaminated gravel and debris using a trailer mounted Hepa vacuum per work plan provided by J. Tech Industrial Hygiene Services.

## Project Costs

Republic will provide the above listed services per the pricing schedule below:



Sustainability in Action

DESCRIPTION	QTY	UOM	Unit Rate	TOTAL
<b>Labor</b>				
Project Manager	1	Hour	\$127.00	\$127.00
<b>Asbestos Removal and Disposal</b> - Set up regulated work and decontamination clean area. Remove & dispose of approx. 16,000 SF. of Asbestos contaminated gravel and debris from hard pan and Strong Rd. bike lane using trailer mounted Hepa Vacuum per work plan provided by J Tech Industrial Hygiene Service.	1	Each	\$72,953.00	\$72,953.00
			<b>Labor Subtotal</b>	\$73,080.00
<b>Waste Disposal</b>				
WA State Intent /Affidavit Fee	2	Each	\$40.00	\$80.00
			<b>Waste Disposal Subtotal</b>	\$80.00
			<b>SUBTOTAL</b>	\$73,160.00
Environmental, Energy, Compliance (EEC) Fee at			10.00%	\$7,316.00
<b>TOTAL PRICE:</b>				<b>\$80,476.00</b>

## Assumptions & Exclusions

- **Republic Services EEC fee will be charged on your services. The EEC fluctuates monthly and will be charged as a percentage of all invoiced charges, excluding taxes state, and local fees. For more information about this fee, please visit [www.republicservices.com/customer-support/fee-disclosures](http://www.republicservices.com/customer-support/fee-disclosures)**
- **Services includes Air Monitoring, Washington State certified asbestos Supervisor and workers. Asbestos liability insurance. Transportation and disposal at an EPA approved Facility. Notification and fees for Spokane Regional Clean Air agency and L&I.**
- **Price Assumes one mobilization, Contractor will provide Temporary Water and Power during Abatement activities.**
- **Change orders- will be issued if scope of work changes or agreement extends past proposal timelines, including Overtime.**
- Proposed disposal prices contained herein are contingent upon the receipt of a signed waste profile sheet from the generator and acceptance of the waste by the designated disposal facility. Pricing and transportation to end facility are contingent upon profile approval.
- Waste streams not matching approved profiles will be considered non-conforming and subject to additional disposal charges or returned to point of generation at customer's expense.



## Sustainability in Action

- **Quoted rates are not inclusive of state or local taxes**
- Pricing is valid for 30 days from proposal date.
- Customer acknowledges pricing will be assessed annually based on consumer price index customarily ranging from 2%-10%.
- Customer and Republic agree to the attached Terms and Conditions.
- The above-provided pricing is expressly conditioned upon acceptance of Net 30 payment terms.
- Republic will not accept any Radioactive, Shock Sensitive, Dioxin or Dioxin Forming Compounds, Pathological Waste or Materials not specifically identified under the project scope.
- Unit rate items are provided for budgetary purposes only. Final costs will be based on the actual quantities required to complete the project as proposed.
- Pricing is based upon **-prevailing wage rates** and work being performed during normal business hours (between 0700 and 1700), Monday through Friday.
- Overtime rates for hourly employees will apply for work performed outside of normal business hours or shifts over 8 hours.
- Pickup for disposal will be scheduled once profile is approved at end facility.
- Republic will have free and ready access to the work site and will be unimpeded through project completion.

If you have any questions about this proposal or need additional information, you can reach me by cell phone at 509-290-4159 or via e-mail at [mgemmell3@republicservices.com](mailto:mgemmell3@republicservices.com) We look forward to helping you with this scope of work or any other environmental service needs.

Respectfully,

**Thanks,**

*Marcus Gemmell*



Sustainability in Action

**Marcus Gemmell**

Territory Sales Executive

21 N. Julia St.

Spokane, WA. 99202

e [mgemmell3@republicservices.com](mailto:mgemmell3@republicservices.com)

o 509-536-5960

c 509-290-4159

w [RepublicServices.com](http://RepublicServices.com)

**24/7 Emergency Response: 800.899.4672**

RE: City of Spokane – Asbestos Removal & Disposal – N. Austin Rd-between W. Strong Rd. & W. Walker Ave.  
Spokane WA.

This proposal is based upon an established Service Agreement between Republic Services or an affiliate and City of Spokane . To accept this proposal, please sign below and we will work with you to schedule the work.

To accept this proposal, please sign below and we will work with you to schedule the work.

Accepted:

City of Spokane

Customer Name

Marlene C Feist

Signature of Authorized Representative

Marlene C Feist

Printed Name

Public Works Director

Title

9/26/24

Date



< Business Lookup

License Information:

[New search](#) [Back to results](#)

**Entity name:** NRC ENVIRONMENTAL SERVICES INC.

**Business name:** NRC ENVIRONMENTAL SERVICES INC.

**Entity type:** [Profit Corporation](#)

**UBI #:** 601-421-393

**Business ID:** 001

**Location ID:** 0003

**Location:** Active

**Location address:** 21 N JULIA ST  
SPOKANE WA 99202-6013

**Mailing address:** 9520 10TH AVE S  
STE 100  
SEATTLE WA 98108-5068

**Excise tax and reseller permit status:** [Click here](#)

**Secretary of State status:** [Click here](#)

Endorsements

Endorsements held at this loca	License #	Count	Details	Status	Expiration date	First issuance d
<a href="#">Chelan General Business Non-Resident</a>				Active	Oct-31-2024	Dec-02-2020
<a href="#">Quincy General Business - Non-Resident</a>				Active	Oct-31-2024	Dec-09-2020
<a href="#">Spokane General Business</a>	T13089598BUS			Active	Oct-31-2024	Oct-15-2012
<a href="#">Spokane Valley General Business - Non-Resident</a>				Active	Oct-31-2024	Dec-28-2022
<a href="#">Walla Walla General Business - Non-Resident</a>				Active	Oct-31-2024	Dec-28-2022
<a href="#">Wenatchee General Business - Non-Resident</a>				Active	Oct-31-2024	Dec-28-2022



## Governing People May include governing people not registered with Secretary of State

Filter

Governing people	Title
ARAMBULA, JULIA	
BINDER, SCOTT	
BOYD, CALVIN R.	
CARLSEN, ELYSE M.	
FOCAZIO, LAWRENCE D.	
HENRY, MATTHEW	
KASARJIAN, ASHLEY	
MACALUSO, JAMES M.	
MCKEON, LAUREN	
NICKERSON, JOHN B.	
SCHEERER, VINCE	
WILHOIT, ADRIENNE W.	

[View Additional Locations](#)

The Business Lookup information is updated nightly. Search date and time: 10/10/2024 8:39:45 AM

[Contact us](#)

How are we doing?

[Take our survey!](#)

Don't see what you expected?

[Check if your browser is supported](#)









# ADDITIONAL REMARKS SCHEDULE

<b>AGENCY</b> _____ <b>POLICY NUMBER</b> See First Page <b>CARRIER</b> See First Page	<b>NAMED INSURED</b> REPUBLIC SERVICES, INC. 18500 N. ALLIED WAY PHOENIX, AZ 85054 <b>EFFECTIVE DATE:</b> _____
<b>NAIC CODE</b> _____	

**ADDITIONAL REMARKS**

**CERTIFICATE NUMBER: 2464023**

THIS ADDITIONAL REMARKS FORM IS A SCHEDULE TO ACORD FORM.

FORM NUMBER: 25 FORM TITLE: CERTIFICATE OF LIABILITY INSURANCE

The following provisions apply when required by written contract. As used below, the term certificate holder also includes any person or organization that the insured has become obligated to include as a result of an executed contract or agreement.

**GENERAL LIABILITY:**

Certificate holder is Additional Insured including on-going and completed operations when required by written contract.  
 Coverage is primary and non-contributory when required by written contract.  
 Waiver of Subrogation in favor of the certificate holder is included when required by written contract.

Medical Payment coverage is available under the General Liability policy only when required by written agreement and limited to the amount required in the agreement or the maximum sublimit found within the General Liability policy, whichever is less.

**AUTO LIABILITY:**

Certificate holder is Additional Insured when required by written contract.  
 Coverage is primary and non-contributory when required by written contract.  
 Waiver of Subrogation in favor of the certificate holder is included when required by written contract.

**WORKERS COMPENSATION AND EMPLOYERS LIABILITY:**

Waiver of Subrogation in favor of the certificate holder is included when required by written contract where allowed by state law.

Stop gap coverage for ND and WA is covered under policy no. WLR C57256862 and stop gap coverage for OH is covered under policy no. WCU C57257829 as noted on page 1 of this certificate.

**TEXAS EXCESS INDEMNITY AND EMPLOYERS LIABILITY:**

Insured is a registered non-subscriber to the Texas Workers Compensation Act. Insured has filed an approved Indemnity Plan with the Texas Department of Insurance which offers an alternative in benefits to employees rather than the traditional Workers Compensation Insurance in Texas. The excess policy (TNS C57194790) shown on this certificate provides excess Indemnity and Employers Liability coverage for the approved Indemnity Plan.

Contractual Liability is included in the General Liability and Automobile Liability coverage forms. The General Liability and Automobile Liability policies do not contain endorsements excluding Contractual Liability.

Separation of Insured (Cross Liability) coverage is provided to the Additional Insured, when required by written contract, per the Conditions of the Commercial General Liability Coverage form and the Automobile Liability Coverage form.

Umbrella/Excess Liability provides additional limits over the underlying General Liability, Automobile Liability and Employer's Liability policies shown on this certificate.

Thirty (30) day notice of cancellation in favor of Certificate Holder from First Named Insured.

**Contractor's Pollution Liability Details of Cover:**

Steadfast Insurance Company (Zurich) (NAIC # 26387) - Policy No. PEC 0792830-01 - \$25MM - 06/30/24 - 06/30/25

**Applicable to the Contractor's Pollution Liability Coverage Parts Only:**

- \$25,000,000 - Damage Limit for Each Occurrence, Claim or Pollution Condition
- \$25,000,000 - Claims Expense Limit for Each Claim
- \$25,000,000 - General Aggregate Limit
- \$25,000,000 - Claims Expense Aggregate Limit

**Applicable to Professional Liability Coverage Parts Only:**

- \$25,000,000 - Damage Limit for Each Claim or Wrongful Act
- \$25,000,000 - Claims Expense Limit for Each Claim
- \$25,000,000 - General Aggregate Limit

**ADDITIONAL INSURED –  
DESIGNATED PERSONS OR ORGANIZATIONS**

Named Insured Republic Services, Inc.			Endorsement Number 22
Policy Symbol ISA	Policy Number H10740083	Policy Period 06/30/2024 to 06/30/2025	Effective Date of Endorsement
Issued By (Name of Insurance Company) ACE American Insurance Company			

Insert the policy number. The remainder of the information is to be completed only when this endorsement is issued subsequent to the preparation of the policy.

**THIS ENDORSEMENT CHANGES THE POLICY. PLEASE READ IT CAREFULLY.**

**This endorsement modifies insurance provided under the following:**

**BUSINESS AUTO COVERAGE FORM  
AUTO DEALERS COVERAGE FORM  
MOTOR CARRIER COVERAGE FORM  
EXCESS BUSINESS AUTO COVERAGE FORM  
EXCESS TRUCKERS COVERAGE FORM**

Additional Insured(s): Any person or organization whom you have agreed to include as an additional insured under written contract or agreement which include permits and licenses requiring DA9U74b (0614), provided such contract or agreement was executed prior to the date of loss.

- A. For a covered "auto," Who Is Insured is amended to include as an "insured," the persons or organizations named in this endorsement. However, these persons or organizations are an "insured" only for "bodily injury" or "property damage" resulting from acts or omissions of:
1. You.
  2. Any of your "employees" or agents.
  3. Any person operating a covered "auto" with permission from you, any of your "employees" or agents.
- B. The persons or organizations named in this endorsement are not liable for payment of your premium.

**NOTICE TO OTHERS ENDORSEMENT - NOTICE BY INSURED'S REPRESENTATIVE**

Named Insured Republic Services, Inc.			Endorsement Number 231
Policy Symbol ISA	Policy Number H10740083	Policy Period 06/30/2024 TO 06/30/2025	Effective Date of Endorsement
Issued By (Name of Insurance Company) ACE American Insurance Company			

**THIS ENDORSEMENT CHANGES THE POLICY. PLEASE READ IT CAREFULLY.**

**THIS ENDORSEMENT MODIFIES INSURANCE PROVIDED UNDER THE FOLLOWING:**

**BUSINESS AUTO COVERAGE FORM**

- A. If we cancel, non-renew, or materially change the Policy prior to its expiration date by notice to the first Named Insured for any reason other than nonpayment of premium, we will, as set out in this endorsement, send written notice of such cancellation, non-renewal or material change, to the first Named Insured and will allow its representative to send such notice to all persons or organizations that the first Named Insured has contractually agreed to provide such notice.
- B. The notice referenced in this endorsement as provided by your representative is intended only to be a courtesy notification. The failure to provide advance notification of cancellation, non-renewal, or material change will impose no obligation or liability of any kind upon us, our agents or representatives, will not extend any Policy cancellation date and will not negate any cancellation, non-renewal or material change of the Policy.
- C. We will only be responsible for sending such notice to the first Named Insured who will notify its representative, and its representative will, in turn, send all applicable persons or organizations notice of cancellation, non-renewal, or material change at least 30 days prior to the applicable event date
- D. This endorsement does not apply in the event that the first Named Insured cancels the Policy.

All other terms and conditions of the Policy remain unchanged.

**WAIVER OF TRANSFER OF RIGHTS OF RECOVERY AGAINST OTHERS**

Named Insured Republic Services, Inc.			Endorsement Number 223
Policy Symbol ISA	Policy Number H10740083	Policy Period 06/30/2024 TO 06/30/2025	Effective Date of Endorsement
Issued By (Name of Insurance Company) ACE American Insurance Company			

Insert the policy number. The remainder of the information is to be completed only when this endorsement is issued subsequent to the preparation of the policy.

**THIS ENDORSEMENT CHANGES THE POLICY. PLEASE READ IT CAREFULLY.**

**This Endorsement modifies insurance provided under the following:**

**BUSINESS AUTO COVERAGE FORM  
MOTOR CARRIERS COVERAGE FORM  
AUTO DEALERS COVERAGE FORM**

We waive any right of recovery we may have against the person or organization shown in the Schedule below because of payments we make for injury or damage arising out of the use of a covered auto. The waiver applies only to the person or organization shown in the SCHEDULE.

**SCHEDULE**

Any person or organization against whom you have agreed to waive your right of recovery in a written contract, provided such contract was executed prior to the date of loss.

**NOTICE TO OTHERS ENDORSEMENT - NOTICE BY INSURED'S REPRESENTATIVE**

Named Insured Republic Services, Inc.			Endorsement Number 61
Policy Symbol HDO	Policy Number G48921000	Policy Period 06/30/2024 TO 06/30/2025	Effective Date of Endorsement
Issued By (Name of Insurance Company) ACE American Insurance Company			

**THIS ENDORSEMENT CHANGES THE POLICY. PLEASE READ IT CAREFULLY.**

**THIS ENDORSEMENT MODIFIES INSURANCE PROVIDED UNDER THE FOLLOWING:**

**COMMERCIAL GENERAL LIABILITY COVERAGE FORM**

- A. If we cancel, non-renew, or materially change the Policy prior to its expiration date by notice to the first Named Insured for any reason other than nonpayment of premium, we will, as set out in this endorsement, send written notice of such cancellation, non-renewal or material change, to the first Named Insured and will allow its representative to send such notice to all persons or organizations that the first Named Insured has contractually agreed to provide such notice.
- B. The notice referenced in this endorsement as provided by your representative is intended only to be a courtesy notification. The failure to provide advance notification of cancellation, non-renewal, or material change will impose no obligation or liability of any kind upon us, our agents or representatives, will not extend any Policy cancellation date and will not negate any cancellation, non-renewal or material change of the Policy.
- C. We will only be responsible for sending such notice to the first Named Insured who will notify its representative, and its representative will, in turn, send all applicable persons or organizations notice of cancellation, non-renewal, or material change at least 30 days prior to the applicable event date
- D. This endorsement does not apply in the event that the first Named Insured cancels the Policy.

All other terms and conditions of the Policy remain unchanged.

**NON-CONTRIBUTORY ENDORSEMENT FOR ADDITIONAL INSURED**

Named Insured Republic Services, Inc.			Endorsement Number 27
Policy Symbol HDO	Policy Number G48921000	Policy Period 06/30/2024 to 06/30/2025	Effective Date of Endorsement
Issued By (Name of Insurance Company) ACE American Insurance Company			

Insert the policy number. The remainder of the information is to be completed only when this endorsement is issued subsequent to the preparation of the policy.

**THIS ENDORSEMENT CHANGES THE POLICY. PLEASE READ IT CAREFULLY.  
COMMERCIAL GENERAL LIABILITY COVERAGE**

**Schedule**

Organization

Any additional insured with whom you have agreed to provide such non-contributory insurance, pursuant to and as required under a written contract executed prior to the date of loss.

Additional Insured Endorsement

CG2026; CG2010; CG2037

*(If no information is filled in, the schedule shall read: "All persons or entities added as additional insureds through an endorsement with the term "Additional Insured" in the title)*

For organizations that are listed in the Schedule above that are also an Additional Insured under an endorsement attached to this policy, the following is added to Section IV.4.a:

If other insurance is available to an insured we cover under any of the endorsements listed or described above (the "Additional Insured") for a loss we cover under this policy, this insurance will apply to such loss on a primary basis and we will not seek contribution from the other insurance available to the Additional Insured.

POLICY NUMBER: HDO G48921000

COMMERCIAL GENERAL LIABILITY  
CG 24 04 05 09

## WAIVER OF TRANSFER OF RIGHTS OF RECOVERY AGAINST OTHERS TO US

This endorsement modifies insurance provided under the following:

COMMERCIAL GENERAL LIABILITY COVERAGE PART  
PRODUCTS/COMPLETED OPERATIONS LIABILITY COVERAGE PART

### SCHEDULE

**Name Of Person Or Organization:**

Any person or organization against whom you have agreed to waive your right of recovery in a written contract requiring CG2404 (05/09), provided such contract was executed prior to the date of loss.

Information required to complete this Schedule, if not shown above, will be shown in the Declarations.

The following is added to Paragraph **8. Transfer Of Rights Of Recovery Against Others To Us** of **Section IV – Conditions:**

We waive any right of recovery we may have against the person or organization shown in the Schedule above because of payments we make for injury or damage arising out of your ongoing operations or "your work" done under a contract with that person or organization and included in the "products-completed operations hazard". This waiver applies only to the person or organization shown in the Schedule above.

POLICY NUMBER: HDO G48921000

Endorsement Number: 121

**COMMERCIAL GENERAL LIABILITY  
CG 20 37 04 13**

**THIS ENDORSEMENT CHANGES THE POLICY. PLEASE READ IT CAREFULLY.**

**ADDITIONAL INSURED – OWNERS, LESSEES OR  
CONTRACTORS – COMPLETED OPERATIONS**

This endorsement modifies insurance provided under the following:

COMMERCIAL GENERAL LIABILITY COVERAGE PART  
PRODUCTS/COMPLETED OPERATIONS LIABILITY COVERAGE PART

**SCHEDULE**

Name Of Additional Insured Person(s) Or Organization(s)	Location And Description Of Completed Operations
Any Owner, Lessee or Contractor whom you have agreed to include as an additional insured under a written contract requiring CG2037 (0413), provided such contract was executed prior to the date of loss.	All locations where you are performing operations for such additional insured pursuant to any such written contract.
Information required to complete this Schedule, if not shown above, will be shown in the Declarations.	

**A. Section II – Who Is An Insured** is amended to include as an additional insured the person(s) or organization(s) shown in the Schedule, but only with respect to liability for "bodily injury" or "property damage" caused, in whole or in part, by "your work" at the location designated and described in the Schedule of this endorsement performed for that additional insured and included in the "products-completed operations hazard".

However:

1. The insurance afforded to such additional insured only applies to the extent permitted by law; and
2. If coverage provided to the additional insured is required by a contract or agreement, the insurance afforded to such additional insured will not be broader than that which you are required by the contract or agreement to provide for such additional insured.

**B.** With respect to the insurance afforded to these additional insureds, the following is added to **Section III – Limits Of Insurance:**

If coverage provided to the additional insured is required by a contract or agreement, the most we will pay on behalf of the additional insured is the amount of insurance:

1. Required by the contract or agreement; or
2. Available under the applicable Limits of Insurance shown in the Declarations;

whichever is less.

This endorsement shall not increase the applicable Limits of Insurance shown in the Declarations.





## Additional Insured

### Coverage B: Contractor's Pollution Liability

Policy No.	Eff. Date of Pol.	Exp. Date of Pol.	Eff. Date of End.	Producer	Add'l Prem.	Return Prem.
PEC-0792830-01	6/30/2024	6/30/2025	6/30/2024	9509115	n/a	n/a

**Named Insured and Mailing Address:**

REPUBLIC SERVICES INC  
18500 N ALLIED WAY  
PHOENIX, AZ 85054-6164

**Producer:**

ALLIANT INSURANCE SERVICES, INC.  
2000 WEST LOOP S STE 2150  
HOUSTON, TX 77027-3571

**THIS ENDORSEMENT CHANGES THE POLICY. PLEASE READ IT CAREFULLY.**

This endorsement modifies insurance provided under the following:

**Professional Environmental Consultant's Liability Insurance Policy**
**Professional Environmental Consultant's Liability Insurance Policy – Claims Made and Reported Coverage**

Schedule
Name of Person or Organization: Blanket where required by written contract
Contract or Agreement Title/No. : Blanket where required by written contract

In consideration of the payment of premium and the Deductible by you and in reliance upon the statements in the Application made a part hereof, we agree with you, subject to all the terms, exclusions and conditions of the policy and the terms and conditions of this endorsement, that with respect to COVERAGE B: CONTRACTOR'S POLLUTION LIABILITY only, the following changes shall apply:

- I. Pursuant to DEFINITIONS (Section VIII.) definition of "insured" paragraph 4., the person or organization shown in the Schedule above whom you are required to add as an additional "insured" on this policy under the written contract or written agreement shown in the Schedule above and executed and effective prior to the performance of your "covered operations" which is the subject of such written contract or written agreement is added as an additional "insured."
- II. The insurance provided to the additional "insured" person or organization applies only to "claims" arising out of a "pollution event" resulting directly from "covered operations" or "completed operations" of the "covered operations" which are the subject of the written contract or written agreement and only if the "claim" is otherwise covered under the terms and conditions of this policy.
- III. Regardless of the provisions of paragraphs I. and II. above:
  - A. We will not extend any insurance coverage to the additional "insured" person or organization:
    1. That is not provided to you in this policy; or
    2. That is broader coverage than you are required to provide to the additional "insured" person or organization in the written contract or written agreement; and
  - B. We will not provide Limits of Liability to the additional "insured" person or organization that exceed the lower of:
    1. The Limits of Liability provided to you in this policy; or
    2. The Limits of Liability you are required to provide in the written contract or written agreement.
- IV. The insurance provided to the additional "insured" person or organization does not apply to "claims" as a result of any negligence, act, error or omission, or strict liability of the additional "insured" person or organization.

V. The insurance provided by this endorsement is primary insurance and we will not seek contribution from any other insurance available to the person or organization shown in the Schedule unless the other insurance is provided by a contractor other than you for the same "covered operations" or "completed operations" of the "covered operations" and job location. Then we will share with that other insurance by the method described in CONDITIONS (Section VII.) Other Insurance.

VI. Both you and the additional "insured" person or organization agree to cooperate with each other and us with respect to all aspects of coverage provided under this policy. In the event that you and the additional "insured" person or organization are named as defendants in a "claim," and are both entitled to defense under this policy for such "claim," we shall provide common counsel to represent you and the additional "insured" person or organization in a joint defense. If you and the additional "insured" person or organization adopt positions materially adverse to each other with respect to the "claim," we shall provide the defense and make payments for "claim expenses," or any other associated costs of defense payable under this policy, only to you from the point of adversity forward.

The rights and obligations above shall apply in any proceeding and in any forum in which you and the additional "insured" person or organization are a party to a "claim."

**ALL OTHER TERMS AND CONDITIONS OF THE POLICY SHALL APPLY AND REMAIN UNCHANGED.**

**Endorsement # 02**



## Notice to Others of Cancellation or Nonrenewal

<b>THIS ENDORSEMENT CHANGES THE POLICY. PLEASE READ IT CAREFULLY.</b>	
Policy No. PEC 0792830-01	Effective Date: 06/30/2024

This endorsement modifies insurance provided under the:

**Professional Environmental Consultant’s Liability Insurance Policy**

It is agreed that:

The following is added to Subsection VIII.F.:

- A. If we cancel or non-renew this policy by written notice to the first “named insured” shown in the Declarations, we will mail or deliver a copy of such written notice of cancellation or non-renewal:
  - 1. To the name and address corresponding to each person or organization shown in the Schedule below; and
  - 2. At least 10 days prior to the effective date of the cancellation or non-renewal, as advised in our notice to the first “named insured” shown in the Declarations, or the number of days’ notice, if any, indicated in the Schedule below, whichever is longer.
- B. If notice as described above is mailed, proof of mailing will be sufficient proof of such notice.
- C. If for any reason we do not mail or deliver a copy of the written notice as per A. above, the cancellation or non-renewal will still take effect as per the notice to the “named insured”.

<b>SCHEDULE</b>	
<b>Name and Address of Other Person(s) / Organization(s):</b>	<b>Number of Days’ Notice:</b>
To be determined as required by written contract	90

All other terms, conditions, provisions and exclusions of this policy remain the same.



# Waiver of Transfer Rights of Recovery Against Others Blanket as Required by Contract

Policy No.	Eff. Date of Pol.	Exp. Date of Pol.	Eff. Date of End.	Producer	Add'l Prem.	Return Prem.
PEC-0792830-01	6/30/2024	6/30/2025	6/30/2024	9509115	n/a	n/a

**Named Insured and Mailing Address:**

REPUBLIC SERVICES INC  
18500 N ALLIED WAY  
PHOENIX, AZ 85054-6164

**Producer:**

ALLIANT INSURANCE SERVICES, INC.  
2000 WEST LOOP S STE 2150  
HOUSTON, TX 77027-3571

**THIS ENDORSEMENT CHANGES THE POLICY. PLEASE READ IT CAREFULLY.**

This endorsement modifies insurance provided under the following:

**Professional Environmental Consultant's Liability Insurance Policy**

**Professional Environmental Consultant's Liability Insurance Policy - Claims Made and Reported Coverage**

**Professional Consultant's Liability Insurance Policy - Claims Made and Reported Coverage**

**Contractor's Pollution Liability Insurance Policy**

**Contractor's Pollution Liability Insurance Policy - Claims Made and Reported Coverage**

In consideration of the payment of premium and the Deductible by you and in reliance upon the statements in the Application made a part hereof, we agree with you, subject to all the terms, exclusions and conditions of the policy that CONDITIONS, Condition O., Subrogation is amended by the addition of the following:

We waive any right of recovery we may have against any person or organization whom you are required to waive your right of subrogation by a written contract or written agreement executed and effective prior to the performance of your services which is the subject of such written contract or written agreement.

**ALL OTHER TERMS AND CONDITIONS OF THE POLICY SHALL APPLY AND REMAIN UNCHANGED.**

## ADDITIONAL INSURED – WHERE REQUIRED BY WRITTEN CONTRACT

Named Insured Republic Services, Inc.			Endorsement Number 005
Policy Symbol XEU	Policy Number G46782148 008	Policy Period 06/30/2024 to 06/30/2025	Effective Date of Endorsement 06/30/2024
Issued By (Name of Insurance Company) ACE Property and Casualty Insurance Company			

**THIS ENDORSEMENT CHANGES THE POLICY. PLEASE READ IT CAREFULLY.**

**This endorsement modifies insurance provided under the following:**

**ENHANCED COMMERCIAL UMBRELLA LIABILITY POLICY**

The policy is amended as follows:

Section VII. **DEFINITIONS**, “**Insured**”, sub-paragraph 3.h. is deleted and replaced with the following:

- h. Any person or organization that the “Named Insured” agrees to add as an additional “insured” to this policy by written contract or agreement, but only with respect to “occurrences” first taking place after the effective date of the contract or agreement and not for broader coverage than was required under the terms of such written contract or agreement. However, the insurance provided will not exceed the lesser of:
1. The limits of this policy; or
  2. The limits required by said contract or agreement.

All other terms and conditions of this policy remain unchanged.

**WAIVER OF TRANSFER OF RIGHTS OF RECOVERY  
AGAINST OTHERS TO US**

Named Insured <b>Republic Services, Inc.</b>			Endorsement Number 045
Policy Symbol XEU	Policy Number G46782148 008	Policy Period 06/30/2024 to 06/30/2025	Effective Date of Endorsement 06/30/2024
Issued By (Name of Insurance Company) ACE Property & Casualty Insurance Company			

**THIS ENDORSEMENT CHANGES THE POLICY. PLEASE READ IT CAREFULLY.**

**This endorsement modifies insurance provided under the following:**

**ENHANCED COMMERCIAL UMBRELLA LIABILITY POLICY**

The policy is amended as follows:

Section **VI. CONDITIONS, Transfer of Rights of Recovery Against Others to Us** is amended to add the following:

We waive any right of recovery we may have against the person or organization shown in the Schedule below because of payments we make for injury or damage arising out of your ongoing operations or "your work" done under a contract with that person or organization and included in the "products-completed operations hazard". This waiver applies only to the person or organization shown in the Schedule below.

**SCHEDULE**

Name of Person or Organization:

Any person or organization against whom you have agreed to waive your right of recovery in a written contract, provided such contract was executed prior to the date of loss.

All other terms and conditions remain unchanged.

**Workers' Compensation and Employers' Liability Policy**

Named Insured REPUBLIC SERVICES, INC. 18500 N. ALLIED WAY PHOENIX AZ 85054	Endorsement Number
	Policy Number Symbol: WLR Number: C57256862
Policy Period 06-30-2024 <b>TO</b> 06-30-2025	Effective Date of Endorsement 06-30-2024
Issued By (Name of Insurance Company) INDEMNITY INS. CO. OF NORTH AMERICA	
Insert the policy number. The remainder of the information is to be completed only when this endorsement is issued subsequent to the preparation of the policy. This endorsement changes the policy to which it is attached and is effective on the date issued unless otherwise stated.	

**WAIVER OF OUR RIGHT TO RECOVER FROM OTHERS ENDORSEMENT**

We have the right to recover our payments from anyone liable for an injury covered by this policy. We will not enforce our right against the person or organization named in the Schedule. This agreement applies only to the extent that you perform work under a written contract that requires you to obtain this agreement from us.

This agreement shall not operate directly or indirectly to benefit any one not named in the Schedule.

**Schedule**

ANY PERSON OR ORGANIZATION AGAINST WHOM YOU HAVE AGREED TO WAIVE YOUR RIGHT OF RECOVERY IN A WRITTEN CONTRACT, PROVIDED SUCH CONTRACT WAS EXECUTED PRIOR TO THE DATE OF LOSS.

For the states of CA, UT, TX, refer to state specific endorsements.

This endorsement is not applicable in KY, NH, and NJ.

The endorsement does not apply to policies in Missouri where the employer is in the construction group of code classifications. According to Section 287.150(6) of the Missouri statutes, a contractual provision purporting to waive subrogation rights against public policy and void where one party to the contract is an employer in the construction group of code classifications.

For Kansas, use of this endorsement is limited by the Kansas Fairness in Private Construction Contract Act(K.S.A.. 16-1801 through 16-1807 and any amendments thereto) and the Kansas Fairness in Public Construction Contract Act(K.S.A 16-1901 through 16-1908 and any amendments thereto). According to the Acts a provision in a contract for private or public construction purporting to waive subrogation rights for losses or claims covered or paid by liability or workers compensation insurance shall be against public policy and shall be void and unenforceable except that, subject to the Acts, a contract may require waiver of subrogation for losses or claims paid by a consolidated or wrap-up insurance program.



Authorized Agent



**Agenda Sheet for City Council:**

**Committee:** PIES **Date:** 10/21/2024

**Committee Agenda type:** Consent

**Date Rec'd** 10/22/2024

**Clerk's File #** OPR 2023-0240

**Cross Ref #**

**Project #**

**Council Meeting Date:** 11/04/2024

<b>Submitting Dept</b>	CITY ATTORNEY	<b>Bid #</b>	
------------------------	---------------	--------------	--

<b>Contact Name/Phone</b>	MICHAEL 6283	<b>Requisition #</b>	PAID THRU
---------------------------	--------------	----------------------	-----------

<b>Contact E-Mail</b>	MPICCOLO@SPOKANECITY.ORG		
-----------------------	--------------------------	--	--

<b>Agenda Item Type</b>	Contract Item		
-------------------------	---------------	--	--

<b>Council Sponsor(s)</b>	JBINGLE KKLITZKE BWILKERSON		
---------------------------	-----------------------------	--	--

<b>Agenda Item Name</b>	0500 SPECIAL COUNSEL CONTRACT AMENDMENT		
-------------------------	---	--	--

**Agenda Wording**

Amendment of the contract with Keating Bucklin & McCormack, Seattle, WA, outside counsel in the legal matter of Estate of Robert Bradley, et al. v. City of Spokane. The amendment will increase the contract by \$150,000 for a total amount of \$400,000.

**Summary (Background)**

This is a lawsuit against the City for alleged wrongful death of Robert Bradley on September 4, 2022.

Lease? NO Grant related? NO Public Works? NO

**Fiscal Impact**

Approved in Current Year Budget? YES

Total Cost \$

Current Year Cost \$

Subsequent Year(s) Cost \$

**Narrative**

<b>Amount</b>	<b>Budget Account</b>
Expense \$ 100,000	# TBD
Select \$	#
Select \$	#
Select \$	#
\$	#
\$	#





## Continuation of Wording, Summary, Approvals, and Distribution

### Agenda Wording

### Summary (Background)

#### **Approvals**

##### Dept Head

PICCOLO, MIKE

##### Division Director

##### Accounting Manager

BUSTOS, KIM

##### Legal

SCHOEDEL, ELIZABETH

##### For the Mayor

PICCOLO, MIKE

#### **Additional Approvals**

##### PURCHASING

NECHANICKY, JASON

#### **Distribution List**

Stewart A. Estes, sestest@kbmlawyers.com

lsmithson@spokanecity.org

rhulvey@spokanecity.org

shenry@spokanecity.org

Zach.Ray@us.davies-group.com

ahaile@spokanecity.org

ddaniels@spokanecity.org

## Committee Agenda Sheet

### Public Infrastructure, Environment & Sustainability Committee

<b>Committee Date</b>	10/21/24
<b>Submitting Department</b>	Legal
<b>Contact Name</b>	Michael J. Piccolo
<b>Contact Email &amp; Phone</b>	<a href="mailto:MPiccolo@spokanecity.org">MPiccolo@spokanecity.org</a> - #6283
<b>Council Sponsor(s)</b>	CM Bingle and CM Klitzke
<b>Select Agenda Item Type</b>	<input checked="" type="checkbox"/> Consent <input type="checkbox"/> Discussion    Time Requested:
<b>Agenda Item Name</b>	Special Counsel Contract Amendment
<b>Proposed Council Action</b>	<input type="checkbox"/> Approval to proceed to Legislative Agenda <input type="checkbox"/> Information Only
<b>Summary (Background)</b>	<p>The City has an existing contract with Stewart A. Estes and the law firm of KEATING, BUCKLIN &amp; McCORMACK, INC., P.S., as outside counsel services and advice in the legal matter of <u>Estate of Robert Bradley, et al. v. City of Spokane, et al.</u>. This is a lawsuit against the City for the alleged wrongful death of Robert Bradley on September 4, 2022.</p> <p>This amendment will increase the contract by \$150,000 for a total contract amount of \$400,000.00.</p>
<b>Summary (Background)</b>	<p>*use the Fiscal Impact box below for relevant financial information</p>
<p><b>Fiscal Impact</b></p> <p><b>Approved in current year budget?</b>    <input checked="" type="checkbox"/> Yes    <input type="checkbox"/> No    <input type="checkbox"/> N/A</p> <p>Total Cost: <u>400,000.00</u></p> <p>    Current year cost: 250,000.00</p> <p>    Subsequent year(s) cost: \$150,000.00</p> <p><b>Narrative:</b> Please provide financial due diligence review, as applicable, such as number and type of positions, grant match requirements, summary type details (personnel, maintenance and supplies, capital, revenue), impact on rates, fees, or future shared revenue</p> <p><b>Funding Source</b>    <input checked="" type="checkbox"/> One-time    <input type="checkbox"/> Recurring    <input type="checkbox"/> N/A</p> <p>Specify funding source: Select Funding Source*</p> <p>Is this funding source sustainable for future years, months, etc? <a href="#">Click or tap here to enter text.</a></p> <p><b>Expense Occurrence</b>    <input checked="" type="checkbox"/> One-time    <input type="checkbox"/> Recurring    <input type="checkbox"/> N/A</p> <p>Other budget impacts: (revenue generating, match requirements, etc.)</p>	
<p><b>Operations Impacts</b> (If N/A, please give a brief description as to why)</p> <ul style="list-style-type: none"> <li>• What impacts would the proposal have on historically excluded communities? N/A</li> <li>• How will data be collected, analyzed, and reported concerning the effect of the program/policy by racial, ethnic, gender identity, national origin, income level, disability, sexual orientation, or other existing disparities? N/A</li> <li>• How will data be collected regarding the effectiveness of this program, policy, or product to ensure it is the right solution? N/A</li> </ul>	

- Describe how this proposal aligns with current City Policies, including the Comprehensive Plan, Sustainability Action Plan, Capital Improvement Program, Neighborhood Master Plans, Council Resolutions, and others? N/A

**Council Subcommittee Review**

- Please provide a summary of council subcommittee review. If not reviewed by a council subcommittee, please explain why not.



**City of Spokane**  
**CONTRACT AMENDMENT**  
**OUTSIDE COUNSEL**

THIS CONTRACT AMENDMENT is between the **CITY OF SPOKANE**, a Washington State municipal corporation, as ("City"), **KEATING, BUCKLIN & MCCORMACK, INC., P.S.**, whose address is 801 Second Avenue, Suite 1210, Seattle, Washington 98104-1576, as ("Firm"), individually hereafter referenced as a "Party", and together referenced as the "Parties".

WHEREAS, the parties entered into a Contract wherein the Firm agreed to act as Outside Counsel providing legal services and advice to the City regarding the matter of THE ESTATE OF ROBERT BRADLEY, ET. AL. V. CITY OF SPOKANE, and

WHEREAS, additional funds are required, thus the original Contract needs to be formally Amended by this written document; and

NOW, THEREFORE, in consideration of these terms, the parties mutually agree as follows:

**1. CONTRACT DOCUMENTS.**

The Contract dated February 15, 2023, any previous amendments and/or extensions/renewals thereto are incorporated by reference into this document as though written in full and shall remain in full force and effect except as provided herein.

**2. EFFECTIVE DATE.**

This Contract Amendment shall become effective on October 1, 2024.

**4. COMPENSATION.**

The City shall pay an additional amount not to exceed **ONE HUNDRED FIFTY THOUSAND AND NO/100 DOLLARS (\$150,000.00)**, for everything furnished and done under this Contract Amendment. The total amount under the original contract, all previous amendments and this Amendment is **FOUR HUNDRED THOUSAND AND NO/100 DOLLARS (\$400,000.00)**.

IN WITNESS WHEREOF, in consideration of the terms, conditions and covenants contained, or attached and incorporated and made a part, the parties have executed this Contract Amendment by having legally-binding representatives affix their signatures below.

**KEATING, BUCKIN & MCCORMACK,  
INC., P.S.**

**CITY OF SPOKANE**

By \_\_\_\_\_  
Signature Date

By \_\_\_\_\_  
Signature Date

\_\_\_\_\_  
Type or Print Name

\_\_\_\_\_  
Type or Print Name

\_\_\_\_\_  
Title

\_\_\_\_\_  
Title

Attest:

Approved as to form:

\_\_\_\_\_  
City Clerk

\_\_\_\_\_  
Assistant City Attorney

24-203





< Business Lookup

License Information:

[New search](#) [Back to results](#)

Entity name: KEATING, BUCKLIN, AND MCCORMACK, INC., P.S.

Business name: KEATING, BUCKLIN, AND MCCORMACK, INC., P.S.

Entity type: [Professional Service Corporation](#)

UBI #: 600-221-771

Business ID: 001

Location ID: 0001

Location: Active

Location address: 801 2ND AVE  
STE 1210  
SEATTLE WA 98104-1518

Mailing address: 801 2ND AVE  
STE 1210  
SEATTLE WA 98104-1518

Excise tax and reseller permit status: [Click here](#)

Secretary of State status: [Click here](#)

Endorsements

Endorsements held at this location	License #	Count	Details	Status	Expiration date	First issuance date
<a href="#">Issaquah General Business - Non-Resident</a>				Active	Dec-31-2024	Dec-28-2022
<a href="#">Spokane General Business - Non-Resident</a>	T12110036BUS			Active	Dec-31-2024	Mar-11-2015

Governing People May include governing people not registered with Secretary of State

Governing people	Title
COOLEY, ANDREW	
ESTES, STEWART A	
FREEMAN, JAYNE L	
JOLLEY, RICHARD	
RAGONESI, SHANNON M	

The Business Lookup information is updated nightly. Search date and time: 10/15/2024 3:27:43 PM

Contact us

How are we doing?  
[Take our survey!](#)

Don't see what you expected?  
[Check if your browser is supported](#)



< Business Lookup

License Information:

[New search](#) [Back to results](#)

Entity name: KEATING, BUCKLIN, AND MCCORMACK, INC., P.S.

Business name: KEATING, BUCKLIN, AND MCCORMACK, INC., P.S.

Entity type: [Professional Service Corporation](#)

UBI #: 600-221-771

Business ID: 001

Location ID: 0001

Location: Active

Location address: 801 2ND AVE  
STE 1210  
SEATTLE WA 98104-1518

Mailing address: 801 2ND AVE  
STE 1210  
SEATTLE WA 98104-1518

Excise tax and reseller permit status: [Click here](#)

Secretary of State status: [Click here](#)

Endorsements

Endorsements held at this location	License #	Count	Details	Status	Expiration date	First issuance date
<a href="#">Issaquah General Business - Non-Resident</a>				Active	Dec-31-2024	Dec-28-2022
<a href="#">Spokane General Business - Non-Resident</a>	T12110036BUS			Active	Dec-31-2024	Mar-11-2015

Governing People May include governing people not registered with Secretary of State

Governing people	Title
COOLEY, ANDREW	
ESTES, STEWART A	
FREEMAN, JAYNE L	
JOLLEY, RICHARD	
RAGONESI, SHANNON M	

The Business Lookup information is updated nightly. Search date and time: 10/15/2024 3:27:43 PM

Contact us

How are we doing?  
[Take our survey!](#)

Don't see what you expected?  
[Check if your browser is supported](#)



**Agenda Sheet for City Council:****Committee:** PIES **Date:** 10/21/2024**Committee Agenda type:** Consent**Date Rec'd**

10/9/2024

**Clerk's File #**

OPR 2023-1249

**Cross Ref #****Project #****Council Meeting Date:** 11/04/2024**Submitting Dept**

PLANNING &amp; ECONOMIC

**Bid #****Contact Name/Phone**

COLIN QUINN- 6804

**Requisition #**

CR 26795

**Contact E-Mail**

CQUINNHURST@SPOKANECITY.ORG

**Agenda Item Type**

Contract Item

**Council Sponsor(s)**

BWILKERSON JBINGLE KKLITZKE

**Agenda Item Name**

0650 - WEST CENTRAL INFRASTRUCTURE PROJECT – CONTRACT AMENDMENT

**Agenda Wording**

Contract amendment with Kittelson & Associates, Inc. to continue design development for public infrastructure projects within the West Central Neighborhood portion of the West Quadrant Tax Increment Finance District.

**Summary (Background)**

This contract amendment with Kittelson & Associates, Inc. will allow continued project work, building on assessments of neighborhood needs, economic impact analyses, and resident engagement. This amendment allows development of designs for public infrastructure projects within the West Central Neighborhood portion of the West Quadrant Tax Increment Finance District.

Lease? NO

Grant related? YES

Public Works? YES

**Fiscal Impact**

Approved in Current Year Budget? YES

Total Cost \$ 299,677

Current Year Cost \$

Subsequent Year(s) Cost \$

**Narrative**

ARPA Funding.

**Amount****Budget Account**

Expense \$ 299,677

# 1425-88155-57215-54201-97252

Select \$

#

Select \$

#

Select \$

#

\$

#

\$

#



**Continuation of Wording, Summary, Approvals, and Distribution**

**Agenda Wording**

**Summary (Background)**

**Approvals**

<b><u>Dept Head</u></b>	GARDNER, SPENCER
<b><u>Division Director</u></b>	GARDNER, SPENCER
<b><u>Accounting Manager</u></b>	ORLOB, KIMBERLY
<b><u>Legal</u></b>	HARRINGTON,
<b><u>For the Mayor</u></b>	JONES, GARRETT

**Additional Approvals**

<b><u>ACCOUNTING -</u></b>	MURRAY, MICHELLE
<b><u>PURCHASING</u></b>	NECHANICKY, JASON

**Distribution List**

wwilber@kittelso.com	sgardner@spokanecity.org
adavies@kittelso.com	nzollinger@spokanecity.org
mfeist@spokanecity.org	smacdonald@spokanecity.org
kpicanco@spokanecity.org	inote@spokanecity.org
akiehn@spokanecity.org	

## Committee Agenda Sheet

### Public Infrastructure, Environment & Sustainability Committee

<b>Submitting Department</b>	Planning & Economic Development Services
<b>Contact Name</b>	Colin Quinn-Hurst
<b>Contact Email &amp; Phone</b>	<a href="mailto:cquinnhurst@spokanecity.org">cquinnhurst@spokanecity.org</a> ; 509-625-6804
<b>Council Sponsor(s)</b>	CM Klitzke and CM Zappone
<b>Select Agenda Item Type</b>	<input checked="" type="checkbox"/> Consent <input type="checkbox"/> Discussion    Time Requested:
<b>Agenda Item Name</b>	West Central Infrastructure Project – Contract Amendment
<b>Summary (Background)</b>  *use the Fiscal Impact box below for relevant financial information	This contract amendment with Kittelson & Associates, Inc. will allow continued project work, building on assessments of neighborhood needs, economic impact analyses, and resident engagement. This amendment allows development of designs for public infrastructure projects within the West Central Neighborhood portion of the West Quadrant Tax Increment Finance District.
<b>Proposed Council Action</b>	Approval
<b>Fiscal Impact</b>	
Total Cost: \$299,677.	
Approved in current year budget? <input checked="" type="checkbox"/> Yes <input type="checkbox"/> No <input type="checkbox"/> N/A	
Funding Source <input checked="" type="checkbox"/> One-time <input type="checkbox"/> Recurring	
Specify funding source: ARPA	
Expense Occurrence <input checked="" type="checkbox"/> One-time <input type="checkbox"/> Recurring	
Other budget impacts: (revenue generating, match requirements, etc.)	
<b>Operations Impacts (If N/A, please give a brief description as to why)</b>	
What impacts would the proposal have on historically excluded communities?	
The infrastructure investments designed through this contract amendment support improved accessibility for residents in a historically underserved neighborhood. Through public right-of-way improvements, the proposals of this project will connect walking, bicycling and pathway networks, enhancing arterial crossings and intersection treatments throughout the West Central Neighborhood. Gaps in walk and bike facilities currently create barriers that separate residents from parks, amenities and services. Projects developed through this contract amendment will support developers in creating a range of housing and commercial investments that will be accessible to nearby residents.	
How will data be collected, analyzed, and reported concerning the effect of the program/policy by racial, ethnic, gender identity, national origin, income level, disability, sexual orientation, or other existing disparities?	
This amendment to the West Central Infrastructure Project builds on baseline data identifying existing demographics and land-use characteristics within the West Central Neighborhood, focusing on measures of Social Vulnerability as provided by the Centers for Disease Control. The contract	

amendment furthers designs to close gaps in accessible infrastructure, based on direct feedback from neighborhood residents through social mapping exercises, surveys and community meetings.

How will data be collected regarding the effectiveness of this program, policy or product to ensure it is the right solution?

This contract amendment will develop designs built on completed assessments of baseline conditions at focus areas, addressing transportation patterns, gaps and conditions. The project included multiple rounds of public engagement consisting of questionnaires, surveys, and online mapping activities, as well as public meetings and presentations. A Technical Advisory Committee made up of City, County, and agency representatives from the project area provided guidance and feedback throughout the study. A Project Advisory Committee made up of residents and representatives of neighborhood organizations and businesses also provided guidance and review throughout the project. Feedback obtained through these efforts informed the selection of proposed solutions and design concepts that will be furthered through this contract amendment. Subsequent investments, plans, policy changes and studies will use the same data collection methods to determine changes as compared to baseline conditions.

Describe how this proposal aligns with current City Policies, including the Comprehensive Plan, Sustainability Action Plan, Capital Improvement Program, Neighborhood Master Plans, Council Resolutions, and others?

#### Chapter 3, Land Use:

- LU 2: Public Realm Enhancement
- LU 3: Efficient Land Use
- LU 4: Transportation
  - LU 4.6: Transit-Supported Development

#### Chapter 4, Transportation:

- TR 2: Transportation Supporting Land Use
- TR 5: Active Transportation
- TR 6: Commercial Center Access
- TR 7: Neighborhood Access
- TR 9: Promote Economic Opportunity

#### Chapter 7, Economic Development:

- ED 2: Land Available for Economic Activities
- ED 3: Strong, Diverse, and Sustainable Economy

This project aligns with previous studies and plans conducted by the West Central Neighborhood, the City of Spokane, and the Spokane Transit Authority that propose investments in public infrastructure that improves accessibility and safe travel for all neighborhood residents. These studies include [Connect Spokane: A Comprehensive Plan for Public Transportation](#) (2022), the [Chestnut-Elm Neighborhood Greenway Study](#) (2022), the [Dutch Jake's Park Master Plan](#) (2016), the West Central Neighborhood Action Plan (May 2012), and the [West Central Neighborhood Assessment](#) (2005).



**CITY OF SPOKANE**  
**CONTRACT AMENDMENT**  
**Title: WEST CENTRAL INFRASTRUCTURE PROJECT**

This Contract Amendment is made and entered into by and between the **CITY OF SPOKANE** as (“City”), a Washington municipal corporation, and **KITTELSON & ASSOCIATES, INC.**, whose address is 202 East Spokane Falls Blvd, Suite 303, Spokane, Washington 99202 as (“Consultant”), individually hereafter referenced as a “Party”, and together as the “Parties”.

WHEREAS, the parties entered into a Contract wherein the Consultant agreed to provide the Planning and Design Services of the West Central Infrastructure Project for the City; and

WHEREAS, the City desires to provide for sub area planning to increase housing along transportation corridors; and

WHEREAS, the City is authorized to expend ARPA funds for this contract in accordance with Ordinance C36163, as substituted and passed January 3, 2022, (Section 1 (C) ); and

WHEREAS, the Consultant agrees to comply with the attached General Terms and Conditions (see Exhibit D);

WHEREAS, further design work on project concepts (see Exhibit B) requiring additional funds, thus the original Contract needs to be formally Amended by this written document; and

NOW, THEREFORE, in consideration of these terms, the parties mutually agree as follows:

**1. CONTRACT DOCUMENTS.**

The Contract, dated December 6, 2023, and December 15, 2023, any previous amendments, addendums and / or extensions / renewals thereto, are incorporated by reference into this document as though written in full and shall remain in full force and effect except as provided herein.

**2. EFFECTIVE DATE.**

This Contract Amendment shall become effective on December 4, 2023, and shall end December 31, 2025.

**3. COMPENSATION.**

The City shall pay an additional amount not to exceed **TWO HUNDRED NINETY-NINE THOUSAND SIX HUNDRED SEVENTY-SEVEN AND NO/100 DOLLARS (\$299,677.00)**, plus applicable sales tax, for everything furnished and done under this Contract Amendment. This is the maximum amount to be paid under this Amendment, and shall not be exceeded without the prior written authorization of the City, memorialized with the same formality as the original Contract and this document.

IN WITNESS WHEREOF, in consideration of the terms, conditions and covenants contained, or attached and incorporated and made a part, the parties have executed this Contract Amendment by having legally-binding representatives affix their signatures below.

**KITTELSON & ASSOCIATES, INC.**

**CITY OF SPOKANE**

By \_\_\_\_\_  
Signature Date

By \_\_\_\_\_  
Signature Date

\_\_\_\_\_  
Type or Print Name

\_\_\_\_\_  
Type or Print Name

\_\_\_\_\_  
Title

\_\_\_\_\_  
Title

Attest:

Approved as to form:

\_\_\_\_\_  
City Clerk

\_\_\_\_\_  
Assistant City Attorney

**Attachments that are part of this Contract:**  
Exhibit A - Certification Regarding Debarment  
Exhibit B – Consultant - Contract Amendment Fall 2024  
Attachment - ARP/CSLFRF CFDA 21.027  
Attachment – General Terms and Conditions

**EXHIBIT A**

**ATTACHMENT A - CERTIFICATION REGARDING DEBARMENT, SUSPENSION, INELIGIBILITY AND VOLUNTARY EXCLUSION AND FEDERAL FUNDING ACCOUNTABILITY AND TRANSPARENCY ACT (FFATA) CERTIFICATION**

**Certification Regarding Debarment, Suspension, Ineligibility and Voluntary Exclusion**

This certification is required by the regulations implementing Executive Order 12549, Debarment and Suspension, 2 CFR Part 180.

(1) The prospective primary participant certifies to the best of its knowledge and belief that it and its principals:

- (a) Are not presently debarred, suspended, proposed for disbarment, declared ineligible, or voluntarily excluded from covered transactions by any Federal department or agency;
- (b) Have not within a three-year period preceding this application been convicted of or had a civil judgement rendered against them for commission of fraud or a criminal offense in connection with obtaining, attempting to obtain, or performing a public (Federal, State, or local) transaction or contract under a public transaction; violation of Federal or State antitrust statutes or commission of embezzlement, theft, forgery, bribery, falsification or destruction of records, making false statements, tax evasion, receiving stolen property, making false claims, or obstruction of justice;
- (c) Are not presently indicted for or otherwise criminally or civilly charged by a governmental entity (Federal, State, or local) with commission of any of the offenses enumerated in paragraph (1)(b) of this certification; and
- (d) Have not within a three-year period preceding this Agreement had one or more public transactions (Federal, State, or local) terminated for cause or default.

(2) The undersigned agrees by signing this Agreement that it shall not knowingly enter into any lower tier covered transaction with a person who is debarred, suspended, declared ineligible, or voluntarily excluded from participation in this covered transaction.

(3) The undersigned further agrees by signing this Agreement that it will include the following required certification, without modification, in all lower tier covered transactions and in all solicitations for lower tier covered transactions:

Certification Regarding Debarment, Suspension, Ineligibility, and Voluntary Exclusion - Lower Tier Covered Transactions

1. The lower tier contractor certified, by signing this contract that neither it nor its principals is presently debarred, suspended, proposed for debarment, declared ineligible, or voluntarily excluded from participation in this transaction by any Federal department or agency.

(4) The undersigned shall notify the City immediately that if it or a lower tier contractor become debarred, suspended, proposed for debarment, declared ineligible, or voluntarily excluded from covered transactions by any Federal department or agency during the period of performance of this Agreement.

(5) The terms covered transaction, debarred, suspended, ineligible, lower tier covered transaction, person, primary covered transaction, principal, and voluntarily excluded, as used in this exhibit, have the meanings set out in the Definitions and Coverage sections of the rules implementing Executive Order 12549. The undersigned may contact the City for assistance in obtaining a copy of these regulations.

(6) I understand that a false statement of this certification may be grounds for termination of the Agreement.

**By signing this Attachment, the Grantee indicates acceptance of and compliance with all requirements described above.**

ATTACHMENT A - CERTIFICATION REGARDING DEBARMENT, SUSPENSION, INELIGIBILITY AND VOLUNTARY EXCLUSION  
AND FEDERAL FUNDING ACCOUNTABILITY AND TRANSPARENCY ACT (FFATA) CERTIFICATION

**Federal Funding Accountability and Transparency Act (FFATA) Certification**

**The Federal Funding Accountability and Transparency Act (FFATA) seeks to provide the public with greater access to Federal spending information. Due to FFATA requirements, you are required to provide the following information which will be used by the City to comply with federal reporting requirements.**

If certain conditions are met, Grantee must provide names and total compensation of the top five highly compensated Executives. Please answer question 1, and follow the instructions. If directed to question 2, please answer and follow instructions.

1. In Grantee's previous fiscal year, did Grantee receive (a) 80% or more of Grantee's annual gross revenues in U.S. Federal contracts and subcontracts and other Federal financial assistance subject to the Transparency Act, as defined in 2 CFR 170.320; AND (b) \$25,000,000 or more in annual gross revenues from contracts and subcontracts and other Federal financial assistance subject to the Transparency Act, as defined in 2 CFR 170.320?

Yes  If yes, answer question 2 below.

No  If no, stop, you are not required to report names and compensation. Please sign and submit form with the Agreement. \_\_\_\_\_

2. Does the public have access to information about the compensation of Grantee's Executives through periodic reports filed under section 13(a) or 15(d) of the Security Exchange Act of 1934 (15 U.S.C. 78(m)(a), 78o(d)), or section 6104 of the Internal Revenue Code of 1986?

Yes  If yes, stop, you are not required to report names and compensation. Please sign and submit form with the Agreement.

No  If no, you are required to report names and compensation. Please fill out the remainder of this form. \_\_\_\_\_

Please provide the names and Total Compensation of the top five most highly compensated Executives in the space below.

Name:	Total Compensation:
Name:	Total Compensation:
Name:	Total Compensation:
Name:	Total Compensation:
Name:	Total Compensation:

**The Grantee certifies that the information contained on this form is true and accurate.**

**By:**

**Title:**

**Date:**



## EXHIBIT B

# WEST CENTRAL

## CONTRACT AMENDMENT SCOPE OF WORK

### BACKGROUND

This scope of work enacts the contract item “24. Expansion for New Work” that allows expansion of the contract agreement for New Work (work not specified within the original Scope of Work Section of this Agreement, and/or not specified within the original RFP as intended for work for the Agreement, subject to limitations and requirements a-f).

As part of the first phase of the West Central Infrastructure Project, the Project Management Team identified projects including sidewalk infill and crossing improvements that are at multiple locations. This amendment adds new Task 7 (Field Investigations) and Task 8 (Design) for the top 8 to 12 priority projects/locations for advancement to 60% design. The final number of projects/locations taken to 60% design will be contingent on the complexity and extent of the priority projects identified and commensurate with the resources available.

Priority candidate projects:

- Broadway Ave Bike Lanes: Chestnut St to Maple St (approx. 1,900 linear feet)
- Chestnut St Greenway: Bridge Ave to Maxwell Ave (approx. 3,000 linear feet)
- Elm St Greenway: Bridge Ave to Boone Ave (approx. 3,000 linear feet)
- Boone Ave Traffic Calming: Summit Blvd to Ash St (approx. 5,000 linear feet)
- Dean Ave Traffic Calming: Cochran St to Elm St (approx. 2,000 linear feet)
- Nettleton St Traffic Calming: Bridge Ave to Boone Ave (approx. 1,900 linear feet)
- Sidewalk Infill and Repair: Various locations (approx. 5,400 linear feet)
- **Total intersection improvements: 14**

Other candidate projects commensurate on available funds:

- Boone Ave and Summit Blvd Intersection Improvements
- Broadway Ave and Summit Blvd Intersection Improvements
- Ash St to Maple St Accessible Pathway



- Underground features such as utility line sizes, rim elevations, invert elevations, fuel tanks, wells, septic tanks, and drain fields shall be shown as indicated by surface features and other information including as-built drawings as provided by the City and 811 utility company data.
- Survey limits for the candidate projects have been identified as follows:
  - Intersection improvements (up to 20 intersections total): full topographic survey 12' behind curb line, 150' of each intersection approach.
  - Greenways and Bike Lanes: curb-to-curb topographic survey when improvements confined to road prism, 12' behind curb line when sidewalk improvements are required.
  - Sidewalk Infill and Repair: topographic survey from curb line to 12' behind curb line.
- Photos of existing site conditions shall also be taken.
- The horizontal coordinate system will be Washington North Zone and vertical datum of NAVD88 will be used. Conventional and GPS surveying equipment will be used to complete the work as described herein.
- For 30% design, Geospatial Information System (GIS) right-of-way linework will be provided to determine approximate right-of-way impacts.
- For 60% design (up to 5 intersections total), Consultant shall provide established right-of-way linework in locations as needed to resolve right-of-way impacts. Consultant shall retrace all existing right-of-way within the project limits and search all survey records on file with Spokane County, to reestablish existing centerlines of each right-of-way.
- Research deeds and Record Surveys, including but not limited to all property surveys, county road surveys, original county road resolutions, and section corner surveys for up to 5 intersections for 60% design to resolve right-of-way impacts.
- Keep all copies of the research data collected, including but not limited to surveys, title reports, deeds, assessors' maps, county road maps, government corner surveys, and horizontal and vertical control data sheets Consultant's Project file. Consultant shall provide all project-related data and records to the City at the end of the project.
- Survey found property corners, property line fences, and the existing edges of pavement to establish existing road centerlines and rights-of-way, where needed. Consultant shall tie at least one (1) Public Land Survey System (PLSS) corner as necessary to show a relationship to the road centerlines.

### **Task 7 Deliverables:**

- Design topographic information for project/locations (CAD File & PDF)
- 30% design GIS right-of-way linework (CAD File)
- 60% established right-of-way linework (CAD File)

### *TASK 8 – DESIGN*

Consultant will develop 30% and 60% design packages for identified projects/locations. Consultant will prepare 30% and 60% design packages that include appropriate specifications and plan sheets according to City of Spokane standards. Plan sets shall include associated cost estimates.

### *Task 8.1 Preliminary Design (30%)*

Consultants shall prepare preliminary design plans in AutoCAD format and planning level conceptual cost estimates. Unit prices shall be based on recent local bid average unit pricing.

The design plans shall provide sufficient design to establish horizontal construction limits, material quantities, and all major construction activities required to construct the proposed improvements.

The 30% plans will include the following components:

- Title sheet
- General notes, legend, and abbreviations
- Construction details
- Curb ramp details (horizontal design only)
- Signing & pavement marking plans
- Rectangular Rapid Flashing Beacon (RRFB) plans
- Construction plans
- Potential utility conflicts
- Potential right-of-way impacts based on GIS right-of-way linework

The 30% plans will not include:

- Three-dimensional design and detailed grading
- Grading and erosion control plans
- Temporary traffic control plans
- Drainage analysis and details
- RRFB electrical details

The plans will identify potential construction impacts including utilities, tree removals, and right-of-way/easement acquisitions.

### *Task 8.2 Advance Design (60%)*

The City shall provide one set of non-conflicting review comments on the preliminary design. Consultant will address the City's review comments and provide written documentation to the City on the resolution of comments. Consultant will prepare 60% design package which shall include plans, cost estimate, and construction specifications.

60% plans will include the following components:

- Title sheet
- General notes, legend, and abbreviations
- Construction details
- Curb ramp details with detailed grading
- Signing & pavement marking plans
- Rectangular Rapid Flashing Beacon (RRFB) plans with preliminary power source identification
- Construction plans

- Grading and erosion control plans
- Temporary traffic control plans
- Landscaping plans
- Drainage analysis and details
- Potential utility conflicts
- Preliminary right-of-way easements based on established right-of-way linework

The 60% plans will not include:

- Right-of-way legal descriptions
- Existing pavement condition evaluation

Consultant shall prepare the technical specifications following the currently adopted Washington State Department of Transportation (WSDOT)/American Public Works Association (APWA) format.

Consultant shall prepare a cost estimate for the project that includes all anticipated construction items that can be identified at this level of design. Unit prices shall be based on recent local bid average unit pricing.

**Task 8 Deliverables:**

- 30% and 60% construction plans (one electronic copy in PDF format per submittal)
- 30% and 60% construction estimates (one electronic copy in PDF format and/or Excel per submittal)
- 60% construction specifications (PDF and/or Word)
- Responses to 30% City comments (PDF and/or Excel)
- Project files (Word, Excel, PDF, and CAD, as applicable)

**ATTACHMENT – ARP/CSLFRF CFDA 21.027 FUNDING**  
American Rescue Plan (ARP)  
Coronavirus State and Local Fiscal Recovery Funds (CSLFRF)  
Funding Authority: U.S. Department of Treasury  
CFDA# 21.027 – Coronavirus State and Local Fiscal Recovery Funds

The Contractor specifically agrees to comply with all applicable state and federal laws, rules, regulations, requirements, program guidance, including but not limited to the following:

All applicable federal, state, and local laws, regulations, executive orders, OMB Circulars, and/or policies including, but not limited to:

Nondiscrimination laws and/or policies, and safety and health regulations.  
Americans with Disabilities Act (ADA), Age Discrimination Act of 1975,  
Title VI of the Civil Rights Act of 1964, Civil Rights Act of 1968,  
Provisions in Buildings for Aged and Handicapped Persons (RCW 70.92).  
Robert T. Stafford Disaster Relief and Emergency Assistance Act (PL 93-288, as amended),  
Ethics in Public Services (RCW 42.52),  
Covenant Against Contingent Fees (48 CFR Section 52.203-5),  
Public Records Act (RCW 42.56),  
Prevailing Wages on Public Works (RCW 39.12),  
State Environmental Policy Act (RCW 43.21C),  
Shoreline Management Act of 1971 (RCW 90.58),  
State Building Code (RCW 19.27),  
Energy Policy and Conservation Act (PL 94-163, as amended),  
Energy Related Building Standards (RCW 19.27A),

Comply with all procurement requirements of 2 CFR Part 200.317 - 200.327. All sole source contracts expected to exceed \$50,000 must be submitted to Spokane City Purchasing for review and approval prior to the award and execution of a contract.

Any contract awarded to the successful Contractor must contain and/or comply with the following procurement provisions in accordance with 2 CFR Part 200.317 - 200.327:

Contractor must maintain a Conflict of Interest Policy consistent with 2 CFR 200.318(c) that is applicable to all activities funded with the award. All potential conflicts of interest related to this award must be reported to Spokane City and/or U.S. Treasury

- Administrative, contractual, or legal remedies in instances where contractors violate or breach contract terms, and provide for such sanctions and penalties as may be appropriate;
- Compliance with Executive Order 11246, "Equal Employment Opportunity," (30 FR 12319, 12935, 3 CFR Part 1964-1965 Comp., p. 339), as amended by Executive Order 11375, as supplemented in Department of Labor regulations (41 CFR Chapter 60);
- For Capital Expenditures that involve the employment of mechanics of laborers: Compliance with the Contract Work Hours and Safety Standards Act (40 USC 3702 and 3704) as supplemented by Department of Labor Regulations (29 CFR Part 5);
- For all contracts in excess of \$100,000 with respect to water, sewer, or broadband that involve the employment of mechanics of laborers: Compliance with the Contract Work Hours and Safety Standards Act (40 USC 3702 and 3704) as supplemented by Department of Labor Regulations (29 CFR Part 5);
- For construction or repair contracts: Compliance with the Copeland "Anti-Kickback" Act (40 U.S.C. 3145) as supplemented by Department of Labor regulations (29 CFR part 3);
- For construction contracts in excess of \$2,000 when required by Federal grant program legislation:

Compliance with the Davis-Bacon Act (40 U.S.C. 3141-3144 and 3146-3148) as supplemented by Department of Labor regulations (29 CFR part 5); Davis Bacon Act—Does **not** apply to projects funded **solely** with ARPA/CSLFRF CFDA 21.027 funds. However, if other federal funds are also used for the construction project in addition to FRF, and those federal funds require Davis-Bacon compliance, all prime construction contracts in excess of \$2,000 must follow Davis-Bacon Act;

- For construction contracts in excess of \$100,000 that involve the employment of mechanics and laborers: Compliance with the Contract Work Hours and Safety Standard Act (40 U.S.C. 3701-3708) as supplemented by Department of Labor regulations (29 CFR Part 5);
- Compliance with the requirements of 37 CFR Part 401, “Rights to Inventions Made by Nonprofit Organizations and Small Business Firms Under Government Grants, Contracts and Cooperative Agreements,” and any implementing regulations issued by the awarding agency
- For contracts in excess of \$150,000: Compliance with all applicable standards, orders or requirements issued under the Clean Air Act (42 U.S.C. 7401-7671q.) and the Federal Water Pollution Control Act (33 U.S.C. 1251-1387) as amended;
- Compliance with section 6002 of the Solid Waste Disposal Act, as amended by the Resource Conservation and Recovery Act;
- Notice of awarding agency requirements and regulations pertaining to reporting;
- Federal awarding agency requirements and regulations pertaining to copyrights and rights in data;
- Access by Spokane City, the Federal awarding agency, the Comptroller General of the United States, or any of their duly authorized representatives to any books, documents, papers and records, sub-agreements, leases, subcontracts, arrangements, or other third-party agreements of any type, and supporting materials related to those records of the Contractor, which are directly pertinent to that specific contract for the purpose of making audit, examination, excerpts and transcriptions;
- Retention of all required records for **six years** after Spokane City makes final payment and all other pending matters are closed;
- Mandatory standards and policies relating to energy efficiency which are contained in the state energy conservation plan issued in compliance with the Energy Policy and Conservation Act (Pub. L. 94-163, 89 Stat. 871);
- Notice of awarding agency requirements and regulations governing the development, reporting, and disposition of rights to inventions and patents resulting from financial assistance awards (37 C.F.R. Part 401) and the standard patent rights clause (37 C.F.R. section 401.14);
- Compliance with Executive Order 13858 “Strengthening Buy-American Preferences for Infrastructure Projects” as appropriate and to the extent consistent with law; and
- Compliance with 2 C.F.R. § 200.216, prohibitions regarding certain telecommunications and video surveillance services or equipment are mandated by section 889 of the John S. McCain National Defense Authorization Act for Fiscal Year 2019 (FY 2019 NDAA), Pub. L. No. 115-232 (2018).

Any contract awarded to the successful Contractor must contain and/or comply with the following provisions in accordance with 2 CFR Part 200.332(a) - 200.332(a)(1)-200.332(a)(6) Requirements for pass-through entities:

- Identify as a Subaward (2 CFR 200.332(a));
- Federal Award Identification (2 CFR 200.332(a)(1));
- Terms and conditions from ARP/CLFRF (2 CFR 200.332(a)(2));
- Additional City of Spokane imposed requirements based on risk assessment (2 CFR 200.332(a)(3));
- Indirect cost rate (2 CFR 200.332(a)(4));
- Records access & retention (2 CFR 200.332(a)(5));
- Closeout provisions (2 CFR 200.332(a)(6)).

Any contract awarded to the successful Contractor must contain and/or comply with the following provisions in accordance with 2 CFR Part 200.501(a)-200.501(h) Audit Requirements:

- Audit required. A non-Federal entity that expends \$750,000 or more during the non-Federal entity’s fiscal year in Federal awards must have a single or program-specific audit conducted for that year in accordance with the provision of this part (2 CFR 200.501(a));
- Single Audit (2 CFR 200.501(b));
- Program-specific audit election (2 CFR 200.501(c));
- Exemption when Federal awards expended are less than \$750,000(2 CFR 200.501(d));
- Federally Funded Research and Development Centers (2 CFR 200.501(e));
- Subrecipients and contractors (2 CFR 200.501(f));
- Compliance responsibility for contractors (2 CFR 200.501(g));
- For-profit subrecipient (2 CFR 200.501(h)).

Contractor must comply with Executive Orders 12549 and 12689 and 2 C.F.R. Part 180, which restrict awards, subawards, and contracts with certain parties that are debarred, suspended, or otherwise excluded from or ineligible for participation in federal assistance programs or activities. Contractor must certify that it is not presently debarred, suspended or proposed for debarment, declared ineligible, or voluntarily excluded from participating in this Agreement by any federal department or agency.

Contractor must comply with the requirements of 31 U.S.C. § 3729-3733 which prohibits the submission of false or fraudulent claims for payment to the Federal Government. See also 31 U.S.C. § 3801-3812 which details the administrative remedies for false claims and statements made.

Contractor is required to be non-delinquent in their repayment of any Federal debt. Examples of relevant debt include delinquent payroll and other taxes, audit disallowances, and benefit overpayments. See OMB Circular A-129.

Contractor’s costs must be compliant with 2 CFR Part 200 Subpart E Cost Principles.

Contractor must comply with 31 U.S.C. § 1352, which provides that none of the funds provided under an award may be expended by the recipient to pay any person to influence, or attempt to influence an officer or employee of any agency, Member of Congress, an officer, or employee of Congress, or an employee of a Member of Congress in connection with any Federal action concerning an award, making of any federal grant, federal loan, continuation, renewal, amendment or modification of any federal contract, grant loan, or cooperative agreement, and that if any funds other than federal appropriated funds have been paid or will be paid to any person for influencing or attempting to influence an officer or employee of any agency, a Member of Congress, an officer or employee of Congress, or an employee of a Member of Congress in connection with this award, the Contractor will complete and submit Standard Form-LLL, “Disclosure Form to Report Lobbying,” in accordance with its instructions.

In the event of the Contractor’s noncompliance or refusal to comply with any applicable law, regulation, executive order, OMB Circular or policy, Spokane City may rescind, cancel, or terminate the contract in whole or in part in its sole discretion. The Contractor is responsible for all costs or liability arising from its failure to comply with applicable laws, regulations, executive orders, OMB Circulars, or policies.

**CERTIFICATION**

DocuSigned by:  

9/23/2024

\_\_\_\_\_  
Signature, Administrator, or Applicant Agency

\_\_\_\_\_  
Date

wende wilber, Senior Principal Planner

\_\_\_\_\_  
print name and title



## Project Budget Form

Project Name: West Central  
 Project Manager: Wende Wilber  
 KAI Project Number: 293810.000  
 Date: Oct 07, 2024

### LABOR ESTIMATE - West Central

Task	Notes	Staff	Steyn, Hermanus	Wilber, Wende	Davies, Anthony	Wisner, Fred	Milacek, McKenna	1	WORK TASK/ TASK HOURS	WORK TASK/ TASK COST
			HJS	WLW	ARD	FSW	MSM	SL1		
<b>001</b>	<b>Project Management</b>									
	Team coordination			4	4			4	12	\$2,660
	Monthly Progress Reports (12)			6					6	\$1,710
	Reimbursable Expense									\$0
	Task #001 - Subtotal		0	10	4	0	4	0	18	\$4,370
<b>007</b>	<b>Field Investigations</b>									
	<b>7.1 Topographic &amp; ROW Survey</b>									
	Processing of survey data				2			4	6	\$2,110
	Reimbursable Expense									\$45,364
	Task #007 - Subtotal		0	0	2	0	4	6	12	\$47,474
<b>008</b>	<b>Design</b>									
	<b>8.1 Preliminary Design (30%)</b>									
	Meetings (3)			5	5	2		5	17	\$3,815
	Intersections geometric design (14)				8	2		20	54	\$9,590
	Curb ramp design				10	1		30	40	\$14,145
	Signing & pavement marking design				4			16	36	\$6,220
	RRFB design				2			8	26	\$4,470
	Plan set development				16			32	88	\$15,520
	Cost estimate				4			8	20	\$3,540
	QA/QC	2	4			6			12	\$3,260
	Task #008 - Subtotal	4	17	186	25	391	512	1135	\$247,833	
	<b>8.2 Advance Design (60%)</b>									
	Meetings (3)			4	4	1		4	13	\$2,905
	Intersections geometric design (14)				20	2		40	142	\$24,990
	Curb ramp design				20	4		40	144	\$25,480
	Signing & pavement marking design				3	1		20	48	\$8,270
	RRFB design				6			16	38	\$6,650
	Grading and erosion control design				16			24	72	\$12,840
	Temporary traffic control design				16			24	64	\$11,480
	Drainage design				24			48	120	\$21,240
	Plan set development				16			32	88	\$15,520
	Cost estimate				4			8	20	\$3,540
	Specifications				8			16	40	\$7,080
	QA/QC	2	4			6			12	\$3,260
	Reimbursable Expense									\$44,018
	Task #008 - Subtotal	4	17	186	25	391	512	1135	\$247,833	
	TOTAL HOURS	4	27	192	25	399	518			
	LABOR RATE	\$325.00	\$285.00	\$215.00	\$245.00	\$165.00	\$170.00		<b>TOTAL HOURS</b>	<b>TOTAL LABOR</b>
	LABOR COST	\$1,300	\$7,695	\$41,280	\$6,125	\$65,835	\$88,060		<b>1,165</b>	<b>\$210,295</b>

Rates shown above are for budgeting purposes only. Additional staff may be billed at the time services are performed.

<b>TOTAL REIMBURSABLES</b>	<b>\$89,382</b>
<b>TOTAL KAI FEES</b>	<b>\$299,677</b>
<b>TOTAL SUB FEES</b>	<b>\$0</b>
<b>TOTAL PROJECT BUDGET</b>	<b>\$299,677</b>





Project Budget Form

Project Name: West Central  
 Project Manager: SPVV  
 Date: Oct 07, 2024

**LABOR ESTIMATE - West Central**

Task	SPVV Landscape Architects	Notes	Staff					WORK TASK/ TASK HOURS	WORK TASK/ TASK COST
				Sherry	Van Voorhis	Chapman	K.Sherry		
<b>003</b>	<b>Preliminary Design</b>								
	<b>30% Design</b>								
	Crosswalk Locations			16	4	30		\$7,350	
	Greenway Locations			12	2	56		\$9,520	
	Intersection roundabouts			8	2	8		\$2,800	
	Team Meetings			4	2		2	\$1,260	
	<b>60% Design</b>								
	Crosswalk Locations			12	2	15		\$4,395	
	Greenway Locations			8	2	28		\$5,300	
	Intersection roundabouts			6	2	6		\$2,190	
	Team Meetings			4	2		2	\$1,260	
	Reimbursable Expense								
	Task #003 - Subtotal			70	18	143	4	\$34,075	
TOTAL HOURS				70	18	143	4		
LABOR RATE				\$180.00	\$180.00	\$125.00	\$90.00		
LABOR COST				\$12,600	\$3,240	\$17,875	\$360		
								<b>TOTAL HOURS</b>	
								<b>TOTAL LABOR</b>	
								<b>235</b>	
								<b>\$34,075</b>	

Rates shown above are for budgeting purposes only. Additional staff may be billed at the time services are performed.

- 15 crosswalk locations.
- 7 greenway locations
- 2 intersection (roundabouts)

<b>TOTAL REIMBURSABLES</b>	\$0
<b>TOTAL KAI FEES</b>	
<b>TOTAL SUB FEES</b>	\$34,075
<b>TOTAL PROJECT BUDGET</b>	

# WEST CENTRAL

## CONTRACT AMENDMENT SCOPE OF WORK

### BACKGROUND

This scope of work enacts the contract item "24. Expansion for New Work" that allows expansion of the contract agreement for New Work (work not specified within the original Scope of Work Section of this Agreement, and/or not specified within the original RFP as intended for work for the Agreement, subject to limitations and requirements a-f).

As part of the first phase of the West Central Infrastructure Project, the Project Management Team identified projects including sidewalk infill and crossing improvements that are at multiple locations. This amendment adds new Task 7 (Field Investigations) and Task 8 (Design) for the top 8 to 12 priority projects/locations for advancement to 60% design. The final number of projects/locations taken to 60% design will be contingent on the complexity and extent of the priority projects identified and commensurate with the resources available.

Priority candidate projects:

- Broadway Ave Bike Lanes: Chestnut St to Maple St (approx. 1,900 linear feet)
- Chestnut St Greenway: Bridge Ave to Maxwell Ave (approx. 3,000 linear feet)
- Elm St Greenway: Bridge Ave to Boone Ave (approx. 3,000 linear feet)
- Boone Ave Traffic Calming: Summit Blvd to Ash St (approx. 5,000 linear feet)
- Dean Ave Traffic Calming: Cochran St to Elm St (approx. 2,000 linear feet)
- Nettleton St Traffic Calming: Bridge Ave to Boone Ave (approx. 1,900 linear feet)
- Sidewalk Infill and Repair: Various locations (approx. 5,400 linear feet)
- **Total intersection improvements: 14**

Other candidate projects commensurate on available funds:

- Boone Ave and Summit Blvd Intersection Improvements
- Broadway Ave and Summit Blvd Intersection Improvements
- Ash St to Maple St Accessible Pathway



- Underground features such as utility line sizes, rim elevations, invert elevations, fuel tanks, wells, septic tanks, and drain fields shall be shown as indicated by surface features and other information including as-built drawings as provided by the City and 811 utility company data.
- Survey limits for the candidate projects have been identified as follows:
  - Intersection improvements (up to 20 intersections total): full topographic survey 12' behind curb line, 150' of each intersection approach.
  - Greenways and Bike Lanes: curb-to-curb topographic survey when improvements confined to road prism, 12' behind curb line when sidewalk improvements are required.
  - Sidewalk Infill and Repair: topographic survey from curb line to 12' behind curb line.
- Photos of existing site conditions shall also be taken.
- The horizontal coordinate system will be Washington North Zone and vertical datum of NAVD88 will be used. Conventional and GPS surveying equipment will be used to complete the work as described herein.
- For 30% design, Geospatial Information System (GIS) right-of-way linework will be provided to determine approximate right-of-way impacts.
- For 60% design (up to 5 intersections total), Consultant shall provide established right-of-way linework in locations as needed to resolve right-of-way impacts. Consultant shall retrace all existing right-of-way within the project limits and search all survey records on file with Spokane County, to reestablish existing centerlines of each right-of-way.
- Research deeds and Record Surveys, including but not limited to all property surveys, county road surveys, original county road resolutions, and section corner surveys for up to 5 intersections for 60% design to resolve right-of-way impacts.
- Keep all copies of the research data collected, including but not limited to surveys, title reports, deeds, assessors' maps, county road maps, government corner surveys, and horizontal and vertical control data sheets Consultant's Project file. Consultant shall provide all project-related data and records to the City at the end of the project.
- Survey found property corners, property line fences, and the existing edges of pavement to establish existing road centerlines and rights-of-way, where needed. Consultant shall tie at least one (1) Public Land Survey System (PLSS) corner as necessary to show a relationship to the road centerlines.

**Task 7 Deliverables:**

- Design topographic information for project/locations (CAD File & PDF)
- 30% design GIS right-of-way linework (CAD File)
- 60% established right-of-way linework (CAD File)

**TASK 8 – DESIGN**

Consultant will develop 30% and 60% design packages for identified projects/locations. Consultant will prepare 30% and 60% design packages that include appropriate specifications and plan sheets according to City of Spokane standards. Plan sets shall include associated cost estimates.

### **Task 8.1 Preliminary Design (30%)**

Consultants shall prepare preliminary design plans in AutoCAD format and planning level conceptual cost estimates. Unit prices shall be based on recent local bid average unit pricing.

The design plans shall provide sufficient design to establish horizontal construction limits, material quantities, and all major construction activities required to construct the proposed improvements.

The 30% plans will include the following components:

- Title sheet
- General notes, legend, and abbreviations
- Construction details
- Curb ramp details (horizontal design only)
- Signing & pavement marking plans
- Rectangular Rapid Flashing Beacon (RRFB) plans
- Construction plans
- Potential utility conflicts
- Potential right-of-way impacts based on GIS right-of-way linework

The 30% plans will not include:

- Three-dimensional design and detailed grading
- Grading and erosion control plans
- Temporary traffic control plans
- Drainage analysis and details
- RRFB electrical details

The plans will identify potential construction impacts including utilities, tree removals, and right-of-way/easement acquisitions.

### **Task 8.2 Advance Design (60%)**

The City shall provide one set of non-conflicting review comments on the preliminary design. Consultant will address the City's review comments and provide written documentation to the City on the resolution of comments. Consultant will prepare 60% design package which shall include plans, cost estimate, and construction specifications.

60% plans will include the following components:

- Title sheet
- General notes, legend, and abbreviations
- Construction details
- Curb ramp details with detailed grading
- Signing & pavement marking plans
- Rectangular Rapid Flashing Beacon (RRFB) plans with preliminary power source identification
- Construction plans



- Grading and erosion control plans
- Temporary traffic control plans
- Landscaping plans
- Drainage analysis and details
- Potential utility conflicts
- Preliminary right-of-way easements based on established right-of-way linework

The 60% plans will not include:

- Right-of-way legal descriptions
- Existing pavement condition evaluation

Consultant shall prepare the technical specifications following the currently adopted Washington State Department of Transportation (WSDOT)/American Public Works Association (APWA) format.

Consultant shall prepare a cost estimate for the project that includes all anticipated construction items that can be identified at this level of design. Unit prices shall be based on recent local bid average unit pricing.

**Task 8 Deliverables:**

- 30% and 60% construction plans (one electronic copy in PDF format per submittal)
- 30% and 60% construction estimates (one electronic copy in PDF format and/or Excel per submittal)
- 60% construction specifications (PDF and/or Word)
- Responses to 30% City comments (PDF and/or Excel)
- Project files (Word, Excel, PDF, and CAD, as applicable)



< Business Lookup

License Information:

[New search](#) [Back to results](#)

**Entity name:** DOWNTOWN SPOKANE DEVELOPMENT ASSOCIATION

**Business name:** DOWNTOWN SPOKANE DEVELOPMENT ASSOCIATION

**Entity type:** Nonprofit Corporation

**UBI #:** 601-594-116

**Business ID:** 001

**Location ID:** 0002

**Location:** Active

**Location address:** 818 W RIVERSIDE AVE  
STE 120  
SPOKANE WA 99201-0915

**Mailing address:** 818 W RIVERSIDE AVE  
STE 120  
SPOKANE WA 99201-0915

**Excise tax and reseller permit status:** [Click here](#)

**Secretary of State status:** [Click here](#)

Endorsements

Endorsements held at this lo	License #	Count	Details	Status	Expiration da	First issuance
Spokane Nonprofit Business				Active	Dec-31-2024	Jan-15-2014

Governing People May include governing people not registered with Secretary of State

Governing people	Title
CAMERON, EMILIE	
CURRAN, STEPHANIE	
HUDSON, JAMIE	

**Governing people**

**Title**

VARALLO, CHRISTOPHER

**Registered Trade Names**

**Registered trade names**

**Status**

**First issued**

DOWNTOWN SPOKANE PARTNERSHIP

Active

Nov-17-2021

[View Additional Locations](#)

The Business Lookup information is updated nightly. Search date and time: 4/16/2024 1:20:43 PM

**Contact us**

How are we doing?

**Take our survey!**

Don't see what you expected?

**Check if your browser is supported**



**Agenda Sheet for City Council:**

**Committee:** PIES **Date:** 10/21/2024

**Committee Agenda type:** Consent

**Date Rec'd** 10/22/2024

**Clerk's File #** OPR 2023-0884

**Cross Ref #**

**Project #**

**Council Meeting Date:** 11/04/2024

**Submitting Dept** WATER & HYDROELECTRIC SERVICES

**Bid #**

**Contact Name/Phone** DOUG 509-742-8154

**Requisition #** CR26800

**Contact E-Mail** DGREENLUND@SPOKANECITY.ORG

**Agenda Item Type** Contract Item

**Council Sponsor(s)** BWILKERSON JBINGLE KKLITZKE

**Agenda Item Name** 4100 UPRIVER DAM SPILLWAY REHABILITATION ENGINEERING SERVICES

**Agenda Wording**

The City of Spokane Water Department seeks to amend the resulting contract OPR 2023-0884 for additional gate design engineering services.

**Summary (Background)**

During construction of dam safety improvements in 2024, which included repair of one spillway tainter gate, the need for rehabilitation of all gates was identified. Per the terms of the 2023 Engineering Services Department-initiated RFQs for Construction Management & Engineering Support Services for Upriver Dam Improvements.

Lease? NO Grant related? NO Public Works? NO

**Fiscal Impact**

Approved in Current Year Budget? YES

Total Cost \$ 123,588

Current Year Cost \$ 67,890

Subsequent Year(s) Cost \$

**Narrative**

Consultant's cost breakdown was reviewed by the Water Department and determined to be reasonable for professional engineering services.

**Amount**

**Budget Account**

Revenue \$ 67,890.00 # 4100-42490-94340-56501-11051

Select \$ #

Select \$ #

Select \$ #

\$ #

\$ #



**Continuation of Wording, Summary, Approvals, and Distribution**

**Agenda Wording**

**Summary (Background)**

**Approvals**

**Dept Head**

SEARL, LOREN

**Division Director**

FEIST, MARLENE

**Accounting Manager**

ALBIN-MOORE, ANGELA

**Legal**

HARRINGTON,

**For the Mayor**

PICCOLO, MIKE

**Additional Approvals**

**PURCHASING**

PRINCE, THEA

**Distribution List**

James Boag boag@mcmillen.com

rrpenaluna@spokanecity.org

nrussell@spokanecity.org

tlester@spokanecity.org

tprince@spokanecity.org

marcusemmons@mcmillen.com

## Committee Agenda Sheet

### Public Infrastructure, Environment & Sustainability Committee

<b>Committee Date</b>	October 21, 2024
<b>Submitting Department</b>	Water & Hydroelectric Services
<b>Contact Name</b>	Doug Greenlund
<b>Contact Email &amp; Phone</b>	<a href="mailto:dgreenlund@spokanecity.org">dgreenlund@spokanecity.org</a> ; 509-742-8154
<b>Council Sponsor(s)</b>	Wilkerson, Bingle, Klitzke
<b>Select Agenda Item Type</b>	<input checked="" type="checkbox"/> Consent <input type="checkbox"/> Discussion    Time Requested:
<b>Agenda Item Name</b>	4100 Upriver Dam Spillway Rehabilitation Engineering Services Amendment 2
<b>Proposed Council Action</b>	<input checked="" type="checkbox"/> Approval to proceed to Legislative Agenda <input type="checkbox"/> Information Only
<b>Summary (Background)</b>	<p>*use the Fiscal Impact box below for relevant financial information</p> <p>During construction of dam safety improvements in 2024, which included repair of one spillway tainter gate, the need for rehabilitation of all gates was identified. Per the terms of the 2023 Engineering Services Department-initiated RFQu for Construction Management &amp; Engineering Support Services for Upriver Dam Improvements, the City seeks to amend the resulting contract OPR 2023-0884 for additional gate design engineering services.</p>
<p><b>Fiscal Impact</b></p> <p><b>Approved in current year budget?</b>    <input checked="" type="checkbox"/> Yes    <input type="checkbox"/> No    <input type="checkbox"/> N/A</p> <p>Total Cost: <u>\$123,588.00</u></p> <p>    Current year cost: \$123,588.00</p> <p>    Subsequent year(s) cost: \$0</p> <p><b>Narrative:</b> <u>Consultant's cost breakdown was reviewed by the Water Department and determined to be reasonable for professional engineering services.</u></p> <p><b>Funding Source</b>    <input checked="" type="checkbox"/> One-time    <input type="checkbox"/> Recurring    <input type="checkbox"/> N/A</p> <p>Specify funding source: Program revenue</p> <p>Is this funding source sustainable for future years, months, etc? Water Dept CIP, utilizing budget account 4100-42490-94340-56501-11051</p> <p><b>Expense Occurrence</b>    <input checked="" type="checkbox"/> One-time    <input type="checkbox"/> Recurring    <input type="checkbox"/> N/A</p> <p>Other budget impacts: (revenue generating, match requirements, etc.) N/A</p>	
<p><b>Operations Impacts</b> (If N/A, please give a brief description as to why)</p> <ul style="list-style-type: none"> <li>What impacts would the proposal have on historically excluded communities? N/A - the proposal helps the dam safety program. Power from the dam is used by drinking water well pump stations that serve the entire population of the City of Spokane.</li> </ul>	

- How will data be collected, analyzed, and reported concerning the effect of the program/policy by racial, ethnic, gender identity, national origin, income level, disability, sexual orientation, or other existing disparities?  
N/A – this work is for Upriver Dam repairs and not a public-facing program or policy.
- How will data be collected regarding the effectiveness of this program, policy, or product to ensure it is the right solution?  
Deliverables will partly fulfill a gate rehabilitation plan approved by the Federal Energy Regulatory Commission.
- Describe how this proposal aligns with current City Policies, including the Comprehensive Plan, Sustainability Action Plan, Capital Improvement Program, Neighborhood Master Plans, Council Resolutions, and others?  
This work is part of the Capital Improvement Program and is consistent with recommendations for improving dam safety.

#### **Council Subcommittee Review**

- Please provide a summary of council subcommittee review. If not reviewed by a council subcommittee, please explain why not.  
Neither the Sustainability Action nor the Traffic Calming / Photo Red subcommittees under the PIES Committee are applicable to this proposal as the work is performed virtually.



**City of Spokane**  
**CONTRACT AMENDMENT**  
Title: **Construction Management and Engineering Support Services for Upriver Dam**

This Contract Amendment is made and entered into by and between the **City of Spokane** as (“City”), a Washington municipal corporation, and **MCMILLEN, INC.**, whose address is 1471 Shoreline Drive, Suite 100, Boise, Idaho 83702 as (“Consultant”), individually hereafter referenced as a “Party”, and together as the “Parties”.

*WHEREAS, the parties entered into a Contract wherein the Consultant agreed to provide Construction Management and Engineering Support Service for the Upriver Dam Improvement Project; and*

*WHEREAS, a change or revision of the Work has been requested, thus the original Contract needs to be formally Amended by this written document; and*

*NOW, THEREFORE, in consideration of these terms, the parties mutually agree as follows:*

**1. CONTRACT DOCUMENTS.**

The Contract, dated September 11, 2023, any previous amendments, addendums and / or extensions / renewals thereto, are incorporated by reference into this document as though written in full and shall remain in full force and effect except as provided herein.

**2. EFFECTIVE DATE.**

This Contract Amendment shall become effective upon the execution of the Parties, and shall end December 31, 2025.

**3. ADDITIONAL WORK.**

The Scope of Work in the original Contract is revised to include additional engineering services as described in the Consultant’s October 9, 2024, Proposal, attached to this Agreement.

**4. COMPENSATION.**

The City shall pay an additional amount not to exceed **ONE HUNDRED TWENTY-THREE THOUSAND FIVE HUNDRED EIGHTY-EIGHT AND NO/100 DOLLARS (\$123,588.00)** plus sales tax if applicable, for everything furnished and done under this Contract Amendment. This is the maximum amount to be paid under this Amendment, and shall not be exceeded without the prior written authorization of the City, memorialized with the same formality as the original Contract and this document.



IN WITNESS WHEREOF, in consideration of the terms, conditions and covenants contained, or attached and incorporated and made a part, the parties have executed this Contract Amendment by having legally-binding representatives affix their signatures below.

**MCMILLEN, INC.**

**CITY OF SPOKANE**

By \_\_\_\_\_  
Signature Date

By \_\_\_\_\_  
Signature Date

\_\_\_\_\_  
Type or Print Name

\_\_\_\_\_  
Type or Print Name

\_\_\_\_\_  
Title

\_\_\_\_\_  
Title

Attest:

Approved as to form:

\_\_\_\_\_  
City Clerk

\_\_\_\_\_  
Assistant City Attorney

**Attachments that are part of this Agreement:**

Upriver Dam Spillway Gate Pre-Design Study Proposal dated October 9, 2024.

24-210a

# Proposal

To:	Jeanne Finger, PE City of Spokane	Project:	Upriver Dam Spillway Modernization
From:	James Boag, PE Principal Mechanical Engineer	cc:	File
Prepared by:	James Boag, PE Principal Mechanical Engineer	Job No:	
Date:	2024.10.09		
Subject:	Upriver Dam Spillway Gate Pre-Design Study		

## Revision Log

Revision No.	Date	Revision Description
Rev 0	2024.09.24	Initial submittal
Rev 1	2024.10.08	Revised per COS comments
Rev 2	2024.10.09	Revised per COS comments

## 1.0 Project Purpose Understanding

This proposal is a response to the RFP issued by the City of Spokane (COS) to McMillen on 17 September 2024. The RFP requests evaluation of options relating to the refurbishment of structural and mechanical components with the intent of ensuring safe and reliable operations for the next 40-50<sup>1</sup> years.

The RFP requested that the following alternatives be evaluated:

1. Full demolition and replacement with new design
2. Partial demolition and replace in kind
3. Repair identified structural and mechanical deficiencies
4. Another alternative(s) McMillen may propose

---

<sup>1</sup> 40-50 years the expected design life of a refurbished spillway gate and operator system

## 2.0 Background

The Upriver Dam Spillway (Spillway) is approximately 90 years old and is largely in original condition. As would be expected, the condition of the spillway has deteriorated over time and likely needs refurbishment to ensure safe and reliable operations.

McMillen was retained by COS in 2023 in a construction management for the repair of gate 5 after a wire rope failure caused the gate to drop and yield a gate arm. McMillen has significant experience with the design and refurbishment of tainter gate systems and has consulted COS about potential costs and options to bring the aging spillway systems up to current and reliable standards. The RFP is a natural extension of COS' development of this project to ensure that the spillway is functional and safe moving forward.

## 3.0 Project Approach

McMillen proposes the following approach to review information, established recommended alternatives for further evaluation, evaluation of alternatives, and a final recommended scope of work for design and implementation. McMillen proposes evaluating the following alternatives:

- 1. Refurbish existing gates to achieve operational reliability for the next 20-30 years.**  
This alternative will evaluate the current conditions and identify recommended measures to ensure the original function is maintained. Additionally, McMillen will advise the refurbished performance against current state of the industry generally accepted design criteria.
- 2. Replacement of gates, trunnions and appurtenances.** This alternative will evaluate new gates that are designed to current USACE Hydraulic Steel Structures (HSS) standards per USACE EM 1110-2-2107 with an intended design life of 100 years.
- 3. Refurbishment of existing gates, trunnions and appurtenances.** This alternative will evaluate modifications to existing gates with the intent to current USACE Hydraulic Steel Structures (HSS) standards per USACE EM 1110-2-2107 with an intended design life of a minimum of 50 years.
- 4. Refurbishment of existing gate operators and controls for existing or new gates.**  
This alternative will evaluate reuse, refurbishment, or modification of existing equipment that will ensure that the systems will last another design life cycle of 40-50 years. The evaluation basis will be based on USACE EM 1110-2-2610 Mechanical and Electrical Design for Lock and Dam Operating Equipment.

5. **Replacement of gate operators and controls.** This alternative will evaluate the replacement of the existing gate operators with new operators and controls. This will provide preliminary sizing, layout and price of new wire rope gate operators. The evaluation basis will be based on USACE EM 1110-2-2610 Mechanical and Electrical Design for Lock and Dam Operating Equipment.

Note that alternatives 1-3 are gates focused and 4 & 5 are gate operator and controls focused. Therefore, the evaluation and recommendation(s) will be a combination of gate and operator alternatives, for example 1&4, 2&5, etc.

This report would establish evaluation criteria with a weighted scoring methodology that will ensure that:

1. The solution meets the required operational and design criteria,
2. The solution is compliant with currently established regulatory requirements including COS' 9<sup>th</sup> Part 12D CAR recommendations,
3. Total lifecycle cost is minimized,
4. Operational reliability and public safety risk are minimized.

McMillen will use 3D modeling, FEM tools, and hand calculations to reverse engineer the existing gates based on existing information. This will allow McMillen to evaluate existing gates and easily iterate gate modifications for various alternatives. The same methods will be used to size a new gate with existing materials, weld design and member sizing sufficient to provide a gate weight and preliminary (~30%) design. McMillen has used this approach on many previous analyses and has found it to be the most efficient approach to look at various scenarios.

## 4.0 Scope Tasks

### 4.1 Assumptions

- Background information will be provided to McMillen in a timely manner this includes
  - Design and as-built drawings of the gates, trunnions, seal plates, bottom sill, dam concrete (with rebar details)
  - Design reports and calculations, if available,
  - Relevant work orders and repair notes, if available,
  - Part 12D reports,

- Relevant portions STI Documents,
- Site specific seismic hazard analyses ,
- Relevant FERC letters or comments,
- Analyses by other consultants or internal staff,
- Trunnion friction tests, if available.
- Adequate design information (drawings, calculations, reports, etc.) is available for McMillen to conduct basic analysis from existing data.
- COS reviews will be 14 calendar days or less.
- COS staff knowledgeable in spillway maintenance and operation will be available to participate in the proposed alternatives workshop.
- COS with decision making authority will be available for the proposed alternatives workshop.
- One site visit will be required for the team’s initial kickoff and information gathering.
- Coordination and update meetings will take place using MS Teams.

#### **4.2 Task 1.0 - Project Management and Administration**

Task 1.0 includes all project administration tasks from NTP through completion of the project. Specific activities include:

- Develop and submit monthly summary billing progress reports.
- Participate in up to 8 virtual 1-hour coordination meetings to discuss project technical aspects, coordination, and schedule.
- Develop provide schedule information/updates as needed.

Table 4-1 Task 1.0 Deliverables

Task 1.0 – Project Management and Administration	
Deliverable	Format
Bi-Weekly Meeting Participation	MS Teams
Meeting Agendas and Notes	PDF
Project Schedule	PDF/P6
Site Visits (1)	In Person

### 4.3 Task 2.0 – Draft Report

McMillen will develop a draft report for COS review. This milestone will include interim steps to fully characterize the project alternatives, component analysis, and engineer’s estimates for cost and schedule required.

1. Information Review – gather and review relevant information
2. Existing Gate Analysis (alternatives 1 & 2) - analyses existing gates using FEM tools and hand calculations to determine existing and possible modification to the existing gates.
3. New gate sizing (alternative 3) – provide a preliminary gate design that complies with current design criteria and be able to be priced by vendors. A rough gate model (~30%) will be developed using FEM and 3D solid model (Autodesk Inventor).
4. Evaluation of existing operators and controls (alternative 4) – analysis of existing condition and capacity and estimates of repairs needed (if any) to last an additional 50 years.
5. Sizing of gate hoist equipment and initial layout to evaluate the cost of a new system (alternative 5).
6. Establish an alternative analysis scoring methodology.
7. Engineer’s estimates for full life cycles for 5 alternatives including the following elements,
  - a. Design, permitting, and procurement costs (COS to provide internal costs as applicable)
  - b. Construction costs (first cost) including construction management,
  - c. O&M costs over a 50-year design lifecycle

- d. Costs will be provided using a net present value using the COS provide rate of return.
8. Alternative workshop. A 3-hour virtual workshop with McMillen and COS will
- a. Present detailed explanations of alternatives
  - b. Scoring methodology
  - c. Scoring of alternatives
  - d. Preferred alternative recommendation with COS to advance
9. Draft Final Report – this report will provide the following
- a. Project background and purpose,
  - b. Important information such as required design and operational criteria summary of the information review,
  - c. Alternative evaluation methodology,
  - d. Analysis summary (details in appendices)
  - e. Description of alternatives
  - f. Evaluation of alternatives including engineering estimates
  - g. Recommendation(s) for future project development utilizing the alternative set chosen during the alternatives workshop.
  - h. Further development of the total project cost estimate of the selected alternative set including:
    - i. Final design, permitting, and procurement costs (COS to provide internal costs as applicable)
    - ii. Construction costs (first cost) including construction management, class 4-5
    - iii. O&M costs over a 50-year design lifecycle, integrated cost considering alternatives selected.
    - iv. Costs will be provided using a net present value using the COS provide rate of return.

**Table 4-2 Task 2.0 Deliverables**

<b>Task 2.0 – Draft Report</b>	
<b>Deliverable</b>	<b>Format</b>
Alternative Workshop Meeting Minutes and Slides	Word/PDF
Draft Final Report	Word/PDF

#### **4.4 Task 3.0 – Final Report**

The final report will finalize the draft report following COS review. Additionally, three full project schedules will be provided to show an optimistic/short, standard, and worst case/long schedule to ensure COS fully understands the range of schedules associated with the selected alternatives set. This will provide the COS with a complete scope of work to be developed in future phases, if warranted.

**Table 4-3 Task 3.0 Deliverables**

<b>Task 3.0 – 60% Design</b>	
<b>Deliverable</b>	<b>Format</b>
Final Report	Word/PDF
Projects Schedules (short/standard/long)	Primavera P6/PDF

## **5.0 Project Team**

The proposed McMillen team has had experience designing numerous dam spillway gate projects of similar size and scope as this Project. The project team proposed includes mechanical, electrical, and structural engineers in addition to the administrative support staff needed to complete this project. McMillen’s team is highly experienced with spillway analysis, design and construction and has been implementing practical solutions for decades. Beyond the team’s extensive McMillen project performed, the proposed design team has over 50 years of combined experience as USACE employees designing and building spillway gates to USACE design standards and have an average of 15 years’ experience.



Our team members consist of:

**Gavin Smith, PE – Project Manager and Structural Lead**

Gavin Smith offers over 17 years of experience performing condition assessment, field investigations, and/or structural analysis for 270+ gates at hydro facilities. He has authored papers on gate retrofits and performed the analysis, design, fabrication inspection, and construction inspection on both gate rehabilitations and gate replacement projects. Gavin has gained a reputation in the industry as an expert in hydraulic steel structures (HSS) and gate design. When employed by USACE Portland District, he was the structural lead for developing the Portland District's standardization guide for upcoming regulating outlet rehabilitations. Gavin spoke at the 2023 Clean Current Conference regarding the recent updates to USACE's hydraulic steel structure codes (EM 1110-2-2107). Due to his extensive experience in the planning, design, and commissioning of HSS, Gavin has been selected to serve on the USSD Gates and Valves Subcommittee which is under the broader Committee on Hydraulics of Dams.

**Matt Hess, PE – Mechanical Lead**

Matt Hess has 18 years of experience as a mechanical engineer. He has focused his career on the hydro industry, working on a broad range of high head lock and dam gate systems, hoists systems, and load handling equipment. He has been the lead designer for numerous hydraulic gate rehabilitation, retrofit, and replacement projects and has performed scoping analysis, feasibility studies, inspections, detailed design, procurement, construction support, and testing and commissioning on these projects.

**Wes Brown, PE – Mechanical Engineer**

Wes Brown has a broad range of skills in hydroelectric powerhouse rehabilitation and turbine-generator design. He has inspected turbine-generator components manufactured in shops worldwide and has experience constructing, aligning, and commissioning turbines and generators in several powerhouses in the Northwest. Wes has experience with crane and hoist systems, intake and outlet works, construction management, contract negotiations, quality assurance/quality control, and root cause and decision-making analysis.

**Jeremy Winkle, PE – Electrical Lead**

Jeremy Winkle is a Registered Professional Engineer with over 15 years of experience. His experience focuses on designing I&C and electrical distribution systems for hydropower, dam upgrades, and other water resource projects. Jeremy has extensive powerhouse and dam

experience and has designed, constructed and commissioned numerous systems on and around dams.

**Grant Wilson – Estimator and Constructability**

Grant Wilson serves as McMillen’s cost engineer and has 27 years of experience. He has also provided valuable insights on construction during the planning phases through constructability reviews, developing construction approaches, as well as planning for site layout, laydown areas, and site access for materials.

**6.0 Cost Summary**

Costs are inclusive of all engineering performed on the project within the confines of the assumptions and McMillen’s understanding of the work. A detailed work breakdown is provided in the appendices for each of the dams.

**Table 6-1 Upriver Dam Cost Summary**

<b>Task</b>	<b>Description</b>	<b>Cost</b>
1.0	Project Management and Administration	\$14,998
2.0	Draft Final Report	\$87,376
3.0	Final Report	\$21,214
	<b>Total</b>	<b><u>\$123,588</u></b>

**7.0 Project Schedule**

McMillen estimates the total project duration to be approximately 120 calendar days however the timing of this project may be affected by the November-December holiday season.

<b>Task</b>	<b>Description</b>	<b>Duration</b>
1.0	Project Management and Administration	120 Days
2.0	Draft Final Report	90 Days
	City of Spokane Review	14 Days
3.0	Final Report	16 Days
	<b>Total</b>	<b><u>120 days</u></b>

## 8.0 Conclusion

McMillen is excited to partner with COS in efforts to improve this important piece of infrastructure. Please do not hesitate to reach out to our Dams Market Lead, James Boag ([boag@mcmillen.com](mailto:boag@mcmillen.com), 971.272.2121) for additional questions regarding this effort.

Sincerely,

A handwritten signature in blue ink that reads "James Boag". The signature is written in a cursive style with a large initial 'J' and a long, sweeping underline.

James Boag  
Dams Market Lead

City of Spokane  
Upriver Dam  
Spillway Feasibility  
Rev 2

Staff	QA/QC & PIC	PM/Structural	Sr ME/Matt	Staff 1	SR EE/	Cost Est/Grant	Tech Writer	Admin	Hours	Total Labor	Airfare	Hotel / Car	Meals	Total Expenses	TOTAL
	Boag/Thurman	Gavin Smith	Hess	Eng/Wes Brown	Jeremy Winkle	Wilson									
Rates	\$ 275	\$ 220	\$ 233	\$ 180	\$ 275	\$ 200	\$ 140	\$ 110							
<b>Task 1 - PM &amp; Administration</b>	4	24	6	10	12	4	-	12	72	\$ 14,998	\$ -	\$ -	\$ -	\$ -	\$ 14,998
PM Admin Duties	4	12						12	28	\$ 5,060				\$ -	\$ 5,060
Meetings and Coordination		12	6	10	8	4			40	\$ 8,838				\$ -	\$ 8,838
Site Visit					4				4	\$ 1,100				\$ -	\$ 1,100
									-	\$ -				\$ -	\$ -
<b>Task 2 - Draft Final Report</b>	14	130	57	131	43	20	16	-	411	\$ 87,376	\$ -	\$ -	\$ -	\$ -	\$ 87,376
Info review		8	6	8	4				26	\$ 5,698				\$ -	\$ 5,698
Existing gate analysis	2	32							34	\$ 7,590				\$ -	\$ 7,590
New gate sizing	2	32							34	\$ 7,590				\$ -	\$ 7,590
New gate operator and control sizing			12	32	12				56	\$ 11,856				\$ -	\$ 11,856
Existing gate operator assessment			12	32	4				48	\$ 9,656				\$ -	\$ 9,656
Alternative scoring methodology		8	4	8	4				24	\$ 5,232				\$ -	\$ 5,232
Engineers Estimate		12	4	16	8	16			56	\$ 11,852				\$ -	\$ 11,852
Alternative Workshop	2	6	3	3	3				17	\$ 3,934				\$ -	\$ 3,934
Draft Final Report	8	32	16	32	8	4	16		116	\$ 23,968				\$ -	\$ 23,968
									-	\$ -				\$ -	\$ -
<b>Task 3 - Final Report</b>	2	26	3	15	3	48	8	-	105	\$ 21,214	\$ -	\$ -	\$ -	\$ -	\$ 21,214
Final Report Revision		6	2	2	2		8		20	\$ 3,816				\$ -	\$ 3,816
Class 4-5 Cost Estimate		12		12		32			56	\$ 11,200				\$ -	\$ 11,200
Project Schedule	2	4				16			22	\$ 4,630				\$ -	\$ 4,630
Compile and stamp report		4	1	1	1				7	\$ 1,568				\$ -	\$ 1,568
									-	\$ -				\$ -	\$ -
<b>Total Hours</b>	20	180	66	156	58	72	24	12	588						
<b>Total Budget</b>	5,500	39,600	15,378	28,080	15,950	14,400	3,360	1,320		\$ 123,588.00				\$ -	123,588.00

NADINE WOODWARD  
MAYOR



CITY OF SPOKANE - PURCHASING  
808 W. Spokane Falls Blvd.  
Spokane, Washington 99201-3316  
(509) 625-6400

**REQUEST FOR QUALIFICATIONS**

**CONSTRUCTION MANAGEMENT & ENGINEERING  
SUPPORT SERVICES  
FOR UPRIVER DAM IMPROVEMENTS**

**City of Spokane, Washington**

**DESCRIPTION: CONSTRUCTION MANAGEMENT & ENGINEERING SUPPORT  
SERVICES FOR UPRIVER DAM IMPROVEMENTS**

**DUE DATE: MONDAY, JULY 24, 2023**  
**No later than 1:00 p.m.**

**DELIVERY: via email to: [dbuller@spokanecity.org](mailto:dbuller@spokanecity.org)**

# 1. INTRODUCTION

## 1.1 BACKGROUND AND PURPOSE

The City of Spokane, through its Department of Engineering Services (hereinafter “City”) is initiating this Request for Qualifications (RFQ) to solicit Proposals from Firms with expertise in construction management, construction engineering, design engineering, and field inspection for a project at the City’s Upriver Dam, a Federal Energy Regulatory Commission (FERC)-licensed hydroelectric facility.

## 1.2 FUNDING

Any contract awarded as a result of this procurement is contingent upon the availability of funding.

A portion of the funding for this project may come from state or federal sources. Where applicable, the contract awarded as a result of this procurement will incorporate the requirements of state or federal funding programs.

## 1.3 PERIOD OF PERFORMANCE

The period of performance of the contract resulting from this RFQ is tentatively scheduled to begin on or about September 18, 2023 and to end on December 31, 2024. Optionally, depending on various factors including the performance of the Firm, the City may extend the contract to add new design engineering services for repair, rehabilitation, and/or replacement of one or more of the existing dam spillway tainter gates and/or other hydroelectric facility components.

## 1.4 DEFINITIONS

Definitions for the purposes of this RFQ include:

**City** – The City of Spokane, a Washington State municipal corporation, that is issuing this RFQ.

**Firm or Consultant** – Individual or company whose Proposal has been accepted by the City and is awarded a fully executed, written contract.

**Proposal** – A formal offer or statement of qualifications submitted in response to this solicitation.

**Proposer** -- Individual or company submitting a Proposal in order to attain a contract with the City.

**Request for Qualifications (RFQ)** – Formal procurement document in which a service or need is identified but no specific method to achieve it has been chosen. The purpose of an RFQ is to permit the consultant community to provide qualifications for evaluation.

## 1.5 CONTRACTING WITH CURRENT OR FORMER CITY EMPLOYEES

Specific restrictions apply to contracting with current or former City officers and employees pursuant to the Code of Ethics in chapter 1.04 of the Spokane Municipal Code. Proposers should familiarize themselves with the requirements prior to submitting a Proposal that includes current or former City officers or employees.

## 1.6 ADDENDA

Addenda will be emailed.

## 2. SCOPE OF SERVICES

The scope of services envisioned in this RFQ include the following:

- Construction management
- Construction inspection
- Construction engineering support
- Material testing coordination
- Design engineering

The project for which the City has issued this RFQ is Upriver Dam Spillway Rehabilitation Phase III (Engineering Services File No. 2022081). The construction package, currently under review by the FERC and attached to this RFQ for reference, consists of plans, specifications, a Construction Potential Failure Modes Analysis (CPFMA) Report, a Quality Control and Inspection Plan (QCIP), and a Temporary Construction Emergency Action Plan (TCEAP). The design was prepared by an engineering firm not currently employed by the City. Upon receipt of remaining permits and approvals, the City expects to bid the project autumn 2023 with construction anticipated winter 2023 through autumn 2024. The successful firm will assist the City during the bidding and construction phases of the project.

Construction management will include contractor and owner coordination, meeting facilitation, record keeping, reporting, and project closeout as described in the specifications and QCIP. The Firm will provide an Owner's Site Representative (OSR) as described in the QCIP.

Construction inspection will include monitoring contractor performance for compliance with the project design and environmental controls. The Firm will provide a part-time QCIP Manager as described in the QCIP.

Construction engineering support will include assistance with bidder questions, contractor qualifications review, contractor submittals review, gate inspection and repair guidance, other office and field engineering as described in the QCIP. The Firm will provide a part-time Construction Engineer as described in the QCIP.

Testing of concrete, steel, concrete reinforcement, grout, adhesive anchors, and water stops / hydrophilic seal materials will be required during the project as described in the QCIP. Testing will be performed by City staff and / or an independent lab contracted by the City, and coordinated by the QCIP Manager or their designee in the Firm.

The City may require design engineering services for additional gate and/or other hydroelectric facility component rehabilitation.

The following documents relevant to this RFQ can be found at the FTP site indicated below.

- Construction Potential Failure Modes Analysis (CPFMA) Report (Upriver CPFMA Report minus Appendices B\_C.pdf)
- Quality Control and Inspection Plan (QCIP) (2023 Spillway Rehab Ph III QCIP.pdf)
- Temporary Construction Emergency Action Plan (TCEAP) (2023 Spillway Rehab Ph III TCEAP.pdf)
- Construction plans (H363793 - Upriver Phase III Drawings\_IFB\_dsp edits2.pdf)
- Specifications (UPRIVER DAM PILLWAY PH 3\_2022081\_COS GSP-REDUCED.pdf)

FTP Link:

<https://ftp.spokanecity.org/?ShareToken=51986704761384F24DBEB5B866107D973F7734AE>

Password: Upriver2023

### 3. GENERAL INFORMATION

#### 3.1 RFQ COORDINATOR

The RFQ Coordinator is the sole point of contact in the City for this procurement. All communication between the Proposer and the City upon receipt of this RFQ shall be with the RFQ Coordinator, as follows:

Name	Dan Buller
Address	808 W. Spokane Falls Blvd., Spokane, WA 99201
Phone Number	509-625-6391
E-Mail Address	<a href="mailto:dbuller@spokanecity.org">dbuller@spokanecity.org</a>

Any other communication will be considered unofficial and non-binding on the City. Firms are to rely on written statements issued by Addendum. Communication directed to parties other than the RFQ Coordinator may result in disqualification of the Firm.

#### 3.2 ESTIMATED SCHEDULE OF PROCUREMENT ACTIVITIES

Step	Expected Dates
Issue Request for Qualifications	6-30-23
Proposals due	7-24-23
Evaluate Proposals	Week of 7-24-23
Conduct oral interviews with finalists, if necessary	Week of 7-31-23
Announce selection, negotiate contract	Weeks of 8-7-23, 7-14-23 and 8-21-23
City Council approval of contract	9-11-23
Contract signatures	Week of 9-11-23
Project kickoff	Week of 9-18-23

The City reserves the right to revise the above schedule.



### **3.3 SUBMISSION OF PROPOSALS**

**Proposals shall be submitted via email to [dbuller@spokanecity.org](mailto:dbuller@spokanecity.org).** The email shall include subject line “SOQ – Upriver Dam Engineering”.

Proposals shall be submitted in pdf format. The entire submittal shall consist of not more than three pdf files (and, ideally, a single pdf file). Note that the City email server will not accept files larger than 10 MB, so files should be configured accordingly. If your submittal is such that you need an FTP link, please email [dbuller@spokanecity.org](mailto:dbuller@spokanecity.org), and an FTP link will be provided.

### **3.4 PROPRIETARY INFORMATION / PUBLIC DISCLOSURE**

Materials submitted in response to this competitive procurement shall become the property of the City.

All received Proposals shall remain confidential until the award of contract. Thereafter, the Proposals shall be deemed public records as defined in RCW 42.56, “Public Records.”

Any information in the Proposal that the Proposer desires to claim as proprietary and thus exempt from disclosure under the provisions of existing state law shall be clearly designated. Each page claimed to be exempt from disclosure must be clearly identified by the word “Confidential” printed on it. Marking the entire Proposal exempt from disclosure will not be honored.

The City will consider a Proposer’s request for exemption from disclosure; however, the City will make a decision predicated upon state law and regulations. If any information is marked as proprietary in the Proposal, it will not be made available until the affected Proposer has been given an opportunity to seek a court injunction against the requested disclosure.

All requests for information should be directed to the RFQ Coordinator.

### **3.5 REVISIONS TO THE RFQ**

In the event it becomes necessary to revise any part of this RFQ or provide any other pertinent information, such revision will be emailed to you.

The City also reserves the right to cancel or reissue the RFQ in whole or in part prior to final award of a contract.

### **3.6 ACCEPTANCE PERIOD**

Proposals shall remain in effect for sixty (60) days for acceptance by the City from the due date for receipt of Proposals.

### **3.7 RESPONSIVENESS**

The Proposer is specifically notified that failure to comply with any part of the RFQ may result in rejection of the Proposal as non-responsive.

The City also reserves the right, however, at its sole discretion to waive minor administrative irregularities.

### **3.8 COSTS TO PROPOSE**

The City will not be liable for any costs incurred by the Proposer in preparation of a Proposal submitted in response to this RFQ, in conduct of a presentation, or any other activities related to responding to this RFQ

### **3.9 NO OBLIGATION TO CONTRACT**

This RFQ does not obligate the City to contract for services specified herein.

### **3.10 REJECTION OF PROPOSALS**

The City reserves the right at its sole discretion to reject any and all Proposals received without penalty and to not issue a contract as a result of this RFQ.

### **3.11 INTERLOCAL PURCHASE AGREEMENTS**

The City of Spokane has entered into Interlocal Purchase Agreements with other public agencies pursuant to RCW 39.34. In submitting a response the Proposer agrees to sell additional items at the contracted price, terms and conditions to the City of Spokane and other public agencies contingent upon the Firm's review and approval at the time of a requested sale. Any price de-escalation/escalation provisions of this Proposal shall apply in the case of a sale of additional items. Firm's right to refuse to sell additional items at the time of request shall be absolute.

## **4. PROPOSAL CONTENTS**

### **4.1 PREPARATION OF PROPOSAL**

Proposals shall be submitted via email. The major sections of the Proposal are to be submitted in the order noted below:

1. Letter of Submittal.
2. Qualifications Statement.

Proposals shall provide information in the same order as presented in this document with the same headings. This will not only be helpful to the evaluators of the Proposal but should assist the Proposer in preparing a thorough response.

### **4.2 LETTER OF SUBMITTAL**

The Letter of Submittal shall be signed (electronic signatures are acceptable) and dated by a person authorized to legally bind the Firm to a contractual relationship, e.g., the president or executive director if a corporation, the managing partner if a partnership, or the proprietor if a sole proprietorship. Along with introductory remarks, the Letter of Submittal is to include the following information about the Firm and any proposed subcontractors:

1. Name, address, principal place of business, telephone number, and fax number/email address of legal entity or individual with whom contract would be written.
2. Legal status of the Firm (sole proprietorship, partnership, corporation, etc.).
3. Location of the facility from which the Firm would operate.
4. Identify any current or former City employees employed by or on the Firm's governing board as of the date of the Proposal or during the previous twelve (12) months.
5. Acknowledgement that the Firm will comply with all terms and conditions set forth in the Request for Qualifications unless otherwise agreed by the City.
6. Acknowledgement that the Firm certifies that it has not been debarred, suspended, ineligible for, or otherwise excluded from participation in Federal Assistance programs under Executive Order 12549, Title 31 U.S. Code 6101 Note, Executive Order 12549, Executive Order 12689, Title 48 Codified Federal Regulation 9.404, "Debarment and Suspension". Further Acknowledge that Firm will not contract with a subcontractor that is likewise debarred, suspended, ineligible for, or otherwise excluded, as referenced in the foregoing Executive Orders, U.S. Codes and Codified Federal Regulations; and the Firm agrees to comply with City requirements to follow cost principals outlined in 2 CFR 200, Subpart E – Cost Principles for financial disbursements under its Grant Agreement. The Firm also agrees to comply with audit requirements outlined in 2 CFR 200 Subpart F – Audit Requirements”.

#### **4.3 PROPOSAL (QUALIFICATION STATEMENT)**

Proposers shall limit their Proposal response to a maximum of 6 pages excluding “letter of submittal”, résumés and reference letters. The Firm's Proposal response to the RFQ shall include at a minimum the following items:

1. A description of the Firm's qualifications/experience in the areas described below.
  - Construction management, especially for projects similar to the City's project
  - Construction inspection, especially for projects similar to the City's project
  - Construction engineering, especially for projects similar to the City's project
  - Design engineering, especially for rehabilitation of dam spillway gates and other components of hydroelectric facilities similar to the City's
2. A staffing plan listing:
  - a) personnel who will be responsible for carrying out the work.
  - b) a description of qualifications, skills (e.g., brief résumés), and responsibilities for each project participant.
3. References of at least three current/former clients (if City staff are listed, they shall be in addition to these three) for whom the Firm performed similar services on similar projects to those described herein. Identify contact persons and email addresses and phone numbers. The Firm grants permission to the City to contact the references. City staff references, if provided,

shall be above and beyond the three references noted above. The City may evaluate references at the City's discretion.

4. Include a list of contracts the Firm has had during the last two (2) years that relate to the Firm's ability to perform the services needed under this RFQ. List contract reference numbers, contract period of performance, contact persons, telephone numbers, and fax numbers/email addresses. The Firm grants permission to the City to contact the references.
5. If the Firm has had a contract terminated for default in the last five (5) years, describe such incident. Termination for default is defined as notice to stop performance due to the Firm's non-performance or poor performance, and the issue of performance was either (a) not litigated due to inaction on the part of the Proposer, or (b) litigated and such litigation determined that the Proposer was in default. Submit full details of the terms for default, including the other party's name, address, and phone number. Present the Firm's position on the matter. The City will evaluate the facts and may, at its sole discretion, reject the Proposal on the grounds of the past experience. If no such termination for default has been experienced by the Firm in the past five (5) years, so indicate.

## **5. EVALUATION**

### **5.1 EVALUATION PROCEDURE**

Responsive Proposals will be evaluated in accordance with the requirements stated in this solicitation and any addenda issued. Evaluation of Proposals shall be accomplished by an evaluation team, to be designated by the City, which will determine the ranking of the Proposals.

The RFQ Coordinator may contact the Firm for clarification of any portion of the Firm's Proposal.

### **5.2 EVALUATION WEIGHTING AND SCORING**

The following weighting will be assigned to the Proposal for evaluation purposes:

Documentation of expertise and experience in construction management, especially for projects similar to the City's project	33%
Documentation of expertise and experience in construction inspection, especially for projects similar to the City's project	33%
Documentation of expertise and experience in design engineering, especially for rehabilitation of dam spillway gates and other components of hydroelectric facilities similar to the City's	34%

### **5.3 AWARD OF CONTRACT**

This RFQ does not obligate the City to award a contract.

Award of contract, when made, will be to the Proposer whose Proposal is the most favorable to the City, taking into consideration the evaluation factors. The Proposer should be prepared to accept this RFQ for incorporation into a contract resulting from this RFQ. Contract negotiations may incorporate some or all of the Proposal.

#### **5.4 DEBRIEFING OF UNSUCCESSFUL PROPOSERS**

Upon request, a debriefing conference will be scheduled with an unsuccessful Proposer. Discussion will be limited to a critique of the requesting Firm's Proposal. Comparisons between Proposals or evaluations of the other Proposals will not be allowed. Debriefing conferences may be conducted in person or on the telephone.

### **6. CONTRACT TERMS**

#### **6.1 BUSINESS REGISTRATION REQUIREMENT**

Section 8.01.070 of the Spokane Municipal Code states that no person may engage in business with the City without first having obtained and been the holder of a valid annual business registration or temporary business registration as provided in this chapter. The Firm shall be responsible for contacting the State of Washington Business License Services at <http://bls.dor.wa.gov> or 1-800-451-7985 to obtain a business registration. If the Firm does not believe it is required to obtain a business registration, it may contact the City's Taxes and Licenses Division at (509) 625-6070 to request an exemption status determination.

#### **6.2 ANTI-KICKBACK**

No officer or employee of the City of Spokane, having the power or duty to perform an official act or action related to this contract shall have or acquire any interest in the contract, or have solicited, accepted or granted a present or future gift, favor, service or other thing of value from or to any person involved in the contract. Any litigation to enforce this contract or any of its provisions shall be brought in Spokane County, Washington.

#### **6.3 DISPUTES**

This contract shall be performed under the laws of Washington State. Any litigation to enforce this contract or any of its provisions shall be brought in Spokane County, Washington.

#### **6.4 TERMINATION**

For Cause: The City or Consultant may terminate the Agreement if the other party is in material breach of this Agreement, and such breach has not been corrected to the other party's reasonable satisfaction in a timely manner. Notice of termination under this Section shall be given by the party terminating this Agreement to the other, not fewer than thirty (30) business days prior to the effective date of termination.

For Reasons Beyond Control of Parties: Either party may terminate this Agreement without recourse by the other where performance is rendered impossible or impracticable for reasons beyond such party's reasonable control, such as, but not limited to, an act of nature, war or

warlike operation, civil commotion, riot, labor dispute including strike, walkout or lockout, except labor disputes involving the Consultant's own employees, sabotage, or superior governmental regulation or control. Notice of termination under this Section shall be given by the party terminating this Agreement to the other, not fewer than thirty (30) business days prior to the effective date of termination.

For Convenience: Either party may terminate this Agreement without cause, upon thirty (30) days written notice to the other party.

Actions upon Termination: if termination occurs not the fault of the Consultant, the Consultant shall be paid for the services properly performed prior to the actual termination date, with any reimbursable expenses then due, but such compensation shall not exceed the maximum compensation to be paid under the Agreement. The Consultant agrees this payment shall fully and adequately compensate the Consultant and all subconsultants for all profits, costs, expenses, losses, liabilities, damages, taxes and charges of any kind (whether foreseen or unforeseen) attributable to the termination of this Agreement.

Upon termination, the Consultant shall provide the City with the most current design documents, contract documents, writings and other products the Consultant has produced to termination, along with copies of all project-related correspondence and similar items. The City shall have the same rights to use these materials as if termination had not occurred; provided however, that the City shall indemnify and hold the Consultant harmless from any claims, losses, or damages to the extent caused by modifications made by the City to the Consultant's work product.

## **6.5. NONDISCRIMINATION**

No individual shall be excluded from participation in, denied the benefit of, subjected to discrimination under, or denied employment in the administration of or in connection with this Contract because of age, sex, race, color, religion, creed, marital status, familial status, sexual orientation including gender expression or gender identity, national origin, honorably discharged veteran or military status, the presence of any sensory, mental or physical disability, or use of a service animal by a person with disabilities. The Firm agrees to comply with, and to require that all subcontractors comply with, Section 504 of the Rehabilitation Act of 1973 and the Americans with Disabilities Act, as applicable to the Firm.

## **6.6 CERTIFICATION REGARDING DEBARMENT, SUSPENSION, INELIGIBILITY AND VOLUNTARY EXCLUSION**

A Certification form will accompany the contract to be signed confirming that, to the best of its knowledge and belief, Firm and its principals;

- a. Are not presently debarred, suspended, proposed for debarment, declared ineligible, or voluntarily excluded from covered transactions by any federal department or agency;
- b. Have not within a three-year period preceding this contract been convicted or had a civil judgment rendered against them for commission of fraud or a criminal offense in connection with obtaining, attempting to obtain, or performing a public (federal, state, or local) transaction or contract under a public transaction; violation of federal or state antitrust statutes or commission of embezzlement, theft, forgery, bribery, falsification or destruction of records, making false statements, tax evasion, receiving stolen property, making false

- claims, or obstruction of justice;
- c. Are not presently indicted or otherwise criminally or civilly charged by a government entity (federal, state, or local) with commission of any of the offenses enumerated in paragraph (1)(b) of this certification; and,
- d. Have not within a three-year period preceding this contract had one or more public transactions (federal, state, or local) terminated for cause or default.

## **6.7 PAYMENT**

Payment will be made via direct deposit/ACH except as provided by state law. A completed ACH application is required before a City Order will be issued. If the City objects to all or any portion of the invoice, it shall notify the Company and reserves the right to only pay that portion of the invoice not in dispute. In that event, the parties shall immediately make every effort to settle the disputed amount.

## **6.8 LIABILITY**

The Firm shall indemnify, defend and hold harmless the City, its officers and employees from all claims, demands, or suits in law or equity arising from the Firm's negligence or breach or its obligations under the contract. The Firm's duty to indemnify shall not apply to liability caused by the sole negligence of the City, its officers and employees. The Firm's duty to indemnify for liability arising from the concurrent negligence of the City, its officers and employees and the Firm, its officers and employees shall apply only to the extent of the negligence of the Firm, its officers and employees. The Firm's duty to indemnify shall survive termination or expiration of the contract. The Firm waives, with respect to the City only, its immunity under RCW Title 51, Industrial Insurance.

## **6.9 INSURANCE COVERAGE**

During the term of the contract, the Firm shall maintain in force at its own expense, each insurance coverage noted below:

- A. Worker's Compensation Insurance in compliance with RCW 51.12.020, which requires subject employers to provide workers' compensation coverage for all their subject workers and Employer's Liability Insurance in the amount of \$1,000,000;
- B. General Liability Insurance on an occurrence basis, with a combined single limit of not less than \$1,000,000 each occurrence for bodily injury and property damage. It shall include contractual liability coverage for the indemnity provided under this contract. It shall provide that the City, its officers and employees are additional insureds but only with respect to the Firm's services to be provided under this contract; and
- C. Automobile Liability Insurance with a combined single limit, or the equivalent of not less than \$1,000,000 each accident for bodily injury and property damage, including coverage for owned, hired and non-owned vehicles.
- D. Professional Liability Insurance with a combined single limit of not less than \$1,000,000 each claim, incident or occurrence. This is to cover damages caused by the error, omission, or negligent acts related to the professional services to be provided under this contract. The coverage must remain in effect for at least three (3) years after the contract is completed.

There shall be no cancellation, material change, reduction of limits or intent not to renew the insurance coverage(s) without forty-five (45) days written notice from the Firm or its insurer(s) to the City.

As evidence of the insurance coverages required by this contract, the Firm shall furnish acceptable insurance certificates to the City at the time it returns the signed contract. The certificate shall specify all of the parties who are additional insured, and include applicable policy endorsements, and the deductible or retention level, as well as policy limits. Insuring companies or entities are subject to City acceptance and must have a rating of A- or higher by Best. Copies of all applicable endorsements shall be provided. The Firm shall be financially responsible for all pertinent deductibles, self-insured retentions, and/or self-insurance.

## **6.10 CONFORMANCE WITH FEDERAL, STATE AND LOCAL LAWS**

Federal, State and Local Laws: Services of a project as a result of the use of a Firm's services including the letting of subcontracts in connection with any project work related to this RFQ may be required to conform to the applicable requirements of Federal, State and local laws and ordinances. The City stipulates that Federal funds may be involved. Note requirements listed in Attachment "A" titled "Federal Grant Funded Guidelines" incorporated herein by reference.

## **6.11 DEBARRED OR SUSPENDED PARTY**

The City will not make any award or permit any award or contract at any tier to any party which is debarred, suspended or in any way is excluded from procurement actions by any Federal, State or Local governmental agency. If information becomes available, such evidence may be grounds for non-award or nullification of the Contract.

## **6.12 MAINTENANCE OF RECORDS**

The Firm will maintain, for at least three (3) years after completion of this contract, all relevant records pertaining to the contract. The Firm shall make available to the City, Washington State Auditor, Federal Grantor Agency, Comptroller General of the United States or any of their duly authorized representatives, at any time during their normal operating hours, all records, books or pertinent information which the Firm shall have kept in conjunction with this Agreement and which the City may be required by law to include or make part of its auditing procedures, an audit trail or which may be required for the purpose of funding the services contracted for herein.

## **6.13 SINGLE AUDIT REQUIREMENTS**

Any contract awarded as a result of this RFQ may include the agreement to annually audit any contracts with the City. Audits shall be performed in accordance with 2 CFR 200 Subpart F – Audit Requirements as appropriate and shall be received by the City within the 12 month period following the close of each fiscal year. Agencies not covered by federal single audit requirements may be responsible for an independent agency audit, which meets general accepted auditing standards.

## **6.14 AMERICANS WITH DISABILITIES ACT INFORMATION**

This material can be made available in an alternate format by emailing Dan Buller at [dbuller@spokanecity.org](mailto:dbuller@spokanecity.org) or by calling 625-6700.



## **6.15 FEDERAL FUNDING NONDISCRIMINATION**

The City of Spokane in accordance with Title VI of the Civil Rights Act of 1964, 78 Stat. 252, 42 U.S.C. 2000d to 2000d-4 and Title 49, Code of Federal Regulations, Department of Transportation, subtitle A, Office of the Secretary, Part 21, nondiscrimination in federally assisted programs of the Department of Transportation issued pursuant to such Act, hereby notifies all bidders that it will affirmatively ensure that in any contract entered into pursuant to this advertisement, disadvantaged business enterprises as defined at 49 CFR Part 26 will be afforded full opportunity to submit bids in response to this invitation and will not be discriminated against on the grounds of race, color, national origin or sex in consideration for an award.

## **ADDENDUM NO. 1**

Date: July 12, 2023

RE: RFQ Construction Management & Engineering Support Services for Upriver Dam Improvements

TO: **All RFQ Recipients**

This is to be considered as Addendum No. 1 to the above project.

*The following is a set of questions we received and the answers we gave.*

Question: Scope identified during the bid and construction phases includes answering contractor questions during bidding and requests for information during construction. Will we as the construction manager have access to the original designers or the City engineer to confirm intent of the design?

Answer: *The City is no longer in a contractual relationship with the original design firm. The winning firm will have access to all City staff that have been involved with this project the past 2.5 years. Also, the original firm's design report will be made available to assist the firm selected as a result of this RFQ in answering contractor questions as needed. City staff will review and approve questions and RFIs before submitted to contractor.*

Question: The QCIP lists Hatch as the Engineer of Record for this project. Will the City be acting as the Engineer of Record for the design during construction?

Answer: *The QCIP does state Hatch as Engineer of Record and Design Engineer and that they are no longer involved with this project. It also describes Construction and Project Engineer roles and responsibilities, roles which we are seeking a consultant to fill by way of this RFQ and filed as part of this construction package with the FERC.*

Question: What additional design scope items should we consider with our team? We have resources that can provide full dam safety scope, dam seismic remediation, concrete repair, earthen spillway repair, powerhouse upgrades/improvements, powerhouse ancillary systems such as trash racks and balance of plant systems, and instrumentation and controls. We want to be sure to include relevant team members and resumes.

Answer: *Optional future design needs for this contract would be limited to dam safety improvements to the principal spillway including gates, abutments, fuse plug, and/or mechanically stabilized earth (MSE) walls. It is anticipated that civil (structural and H&H), mechanical, and/or geotechnical engineering disciplines may be required.*

Question: What is the city's budget for the scope included in the RFQ?

Answer: \$150k – \$350k

---

Question:

Can the City tell us who else they shortlisted to receive the RFQ? If not, can you tell us how many firms were shortlisted?

Answer: *No firms have yet been shortlisted. The RFQ you received was sent to ~600 firms on MRSC's roster.*

Sincerely,



Dan Buller, P.E.  
Principal Engineer Design

Project: RFQ Construction Management &  
Engineering Support Services for Upriver Dam  
Improvements

\*\*\*\*ATTACH THIS SHEET TO YOUR BID PROPOSAL\*\*\*\*

DEPARTMENT OF ENGINEERING SERVICES  
CITY OF SPOKANE  
2ND FLOOR CITY HALL  
808 W SPOKANE FALLS BLVD  
SPOKANE WA 99201-3343

Gentlemen:

I hereby acknowledge receipt of Addendum No. 1 in connection with the above project.

---

(Name)

---

(Address)

## **ADDENDUM NO. 2**

Date: July 13, 2023

RE: RFQ Construction Management & Engineering Support Services for Upriver Dam Improvements

TO: **All RFQ Recipients**

This is to be considered as Addendum No. 2 to the above project.

The following is a set of questions we received and the answers we gave.

Question: What will the RFI process look like?

Answer: *The RFI process is described in section E.2 Design Control During Construction of the QCIP. Any other specifics or enhancements to the process may be proposed by the winning Firm for review and approval by the City.*

### **E.2 DESIGN CONTROL DURING CONSTRUCTION**

#### **i) Design Changes**

- *Changes to the project plans and specifications will be properly identified and documented to ensure all parties involved with this effort are informed of any and all design changes. The Construction Engineer may verbally authorize minor changes which are consistent with the overall intent of the project and the CE will document such changes with a formal written letter.*
- *The OSR will be responsible for ensuring that the Contractor maintains current on-site versions of the specifications. The OSR will be advised of modifications or changes to the Project, which in any way impact dam safety, and will notify the CDSE. The CDSE/COS will be responsible for notifying FERC.*

#### **ii) Nonconformance Reports and Record Drawings**

- *All construction work will conform to the design requirements or be corrected. If changes are made to the design, the Construction Engineer will document final conditions and prepare the final record drawings.*
- *To track action on all work observed to be deficient by the QCIP staff, a quality tracking and reporting system will be developed and maintained by the QCIP Manager. The system will contain information such as report number for tracking, date of issue, originator, description of deficient work, disposition, technical basis for disposition, date of closure, party responsible for closure, and pertinent references.*
- *Non-conformance reports will utilize standard forms similar to that shown in Appendix K.7. The QCIP Manager will also use the Non-conformance*

*Report to document any environmental deficiency requiring remedial action.*

Question: Is the City expecting the Consultant to modify the design drawings and provide a stamp on those modified drawings?

*Answer: The City is expecting the consultant to interpret/clarify design drawings with provided Design Report and/or other project development documents but if interpretation cannot be accomplished, the consultant would be expected to modify or create new design drawings and stamp them. As stated in QCIP Section E.2.ii, "All construction work will conform to the design requirements or be corrected. If changes are made to the design, the Construction Engineer will document final conditions and prepare the final record drawings."*

Question: 0 0 0 0 0 0 0 0 0 0

*Answer: No update other than confirmation they are reviewing it. Project package was submitted to FERC 6/27/2023 and they have a minimum 60 day review period.*

Sincerely,

Dan Buller, P.E.  
Principal Engineer Design

Project: RFQ Construction Management &  
Engineering Support Services for Upriver Dam  
Improvements

\*\*\*\*ATTACH THIS SHEET TO YOUR BID PROPOSAL\*\*\*\*

DEPARTMENT OF ENGINEERING SERVICES  
CITY OF SPOKANE  
2ND FLOOR CITY HALL  
808 W SPOKANE FALLS BLVD  
SPOKANE WA 99201-3343

Gentlemen:

I hereby acknowledge receipt of Addendum No. 2 in connection with the above project.

---

(Name)

---

(Address)



STATE OF WASHINGTON

# BUSINESS LICENSE

Profit Corporation

MCMILLEN, INC.  
STE 100  
1471 W SHORELINE DR  
BOISE ID 83702-9104

UNEMPLOYMENT INSURANCE - ACTIVE  
TAX REGISTRATION - ACTIVE

INDUSTRIAL INSURANCE - ACTIVE

Issue Date: Mar 15, 2024

Unified Business ID #: 602492470

Business ID #: 001

Location: 0001

Expires: Apr 30, 2025

CITY/COUNTY ENDORSEMENTS:

SPOKANE GENERAL BUSINESS - NON-RESIDENT #T11054877BUS - ACTIVE

LICENSING RESTRICTIONS:

Not licensed to hire minors without a Minor Work Permit.

This document lists the registrations, endorsements, and licenses authorized for the business named above. By accepting this document, the licensee certifies the information on the application was complete, true, and accurate to the best of his or her knowledge, and that business will be conducted in compliance with all applicable Washington state, county, and city regulations.

Director, Department of Revenue

UBI: 602492470 001 0001

MCMILLEN, INC.  
STE 100  
1471 W SHORELINE DR  
BOISE ID 83702-9104

FOLD HERE

UNEMPLOYMENT INSURANCE - ACTIVE  
INDUSTRIAL INSURANCE - ACTIVE  
TAX REGISTRATION - ACTIVE  
SPOKANE GENERAL BUSINESS - NON-RESIDENT #T11054877BUS - ACTIVE

FOLD HERE

STATE OF WASHINGTON

Expires: Apr 30, 2025

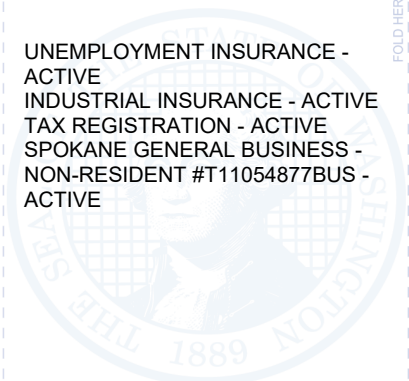

Director, Department of Revenue



## IMPORTANT!

### PLEASE READ THE FOLLOWING INFORMATION CAREFULLY BEFORE POSTING THIS LICENSE

#### General Information

Post this Business License in a visible location at your place of business.

If you were issued a Business License previously, **destroy the old one and post this one in its place.**

Login to My DOR at [dor.wa.gov](http://dor.wa.gov) if you need to make changes to your business name, location, mailing address, telephone number, or business ownership.

Telephone: 360-705-6741

#### Endorsements

All endorsements should be renewed by the expiration date that appears on the front of this license to avoid any late fees.

If there is no expiration date, the endorsements remain active as long as you continue required reporting. Tax Registration, Unemployment Insurance, and Industrial Insurance endorsements require you to submit periodic reports. Each agency will send you the necessary reporting forms and instructions.

For assistance or to request this document in an alternate format, visit <http://business.wa.gov/BLS> or call (360) 705-6741. Teletype (TTY) users may use the Washington Relay Service by calling 711.

BLS-700-107 (07/27/20)



# CERTIFICATE OF LIABILITY INSURANCE

DATE (MM/DD/YYYY)

8/30/2024

THIS CERTIFICATE IS ISSUED AS A MATTER OF INFORMATION ONLY AND CONFERS NO RIGHTS UPON THE CERTIFICATE HOLDER. THIS CERTIFICATE DOES NOT AFFIRMATIVELY OR NEGATIVELY AMEND, EXTEND OR ALTER THE COVERAGE AFFORDED BY THE POLICIES BELOW. THIS CERTIFICATE OF INSURANCE DOES NOT CONSTITUTE A CONTRACT BETWEEN THE ISSUING INSURER(S), AUTHORIZED REPRESENTATIVE OR PRODUCER, AND THE CERTIFICATE HOLDER.

**IMPORTANT:** If the certificate holder is an ADDITIONAL INSURED, the policy(ies) must have ADDITIONAL INSURED provisions or be endorsed. If SUBROGATION IS WAIVED, subject to the terms and conditions of the policy, certain policies may require an endorsement. A statement on this certificate does not confer rights to the certificate holder in lieu of such endorsement(s).

<b>PRODUCER</b> Arthur J. Gallagher Risk Management Services, LLC 2121 N. California Blvd., Suite 350 Walnut Creek, CA 94596  License#: 0D69293	<b>CONTACT NAME:</b> Certificate Department <b>PHONE (A/C, No, Ext):</b> 925-299-1112 <b>E-MAIL ADDRESS:</b> GCSSFCerts@ajg.com	<b>FAX (A/C, No):</b> 925-925-0328	
	<b>INSURER(S) AFFORDING COVERAGE</b>		<b>NAIC #</b>
<b>INSURED</b> McMillen, Inc. 1471 W. Shoreline Drive, Suite 100 Boise, ID 83702	<b>INSURER A:</b> National Union Fire Insurance Company of Pittsburg		19445
	<b>INSURER B:</b> Indian Harbor Insurance Company		36940
	<b>INSURER C:</b>		
	<b>INSURER D:</b>		
	<b>INSURER E:</b>		
<b>INSURER F:</b>			

**COVERAGES** **CERTIFICATE NUMBER:** 1889043804 **REVISION NUMBER:**

THIS IS TO CERTIFY THAT THE POLICIES OF INSURANCE LISTED BELOW HAVE BEEN ISSUED TO THE INSURED NAMED ABOVE FOR THE POLICY PERIOD INDICATED. NOTWITHSTANDING ANY REQUIREMENT, TERM OR CONDITION OF ANY CONTRACT OR OTHER DOCUMENT WITH RESPECT TO WHICH THIS CERTIFICATE MAY BE ISSUED OR MAY PERTAIN, THE INSURANCE AFFORDED BY THE POLICIES DESCRIBED HEREIN IS SUBJECT TO ALL THE TERMS, EXCLUSIONS AND CONDITIONS OF SUCH POLICIES. LIMITS SHOWN MAY HAVE BEEN REDUCED BY PAID CLAIMS.

INSR LTR	TYPE OF INSURANCE	ADDL INSD	SUBR WVD	POLICY NUMBER	POLICY EFF (MM/DD/YYYY)	POLICY EXP (MM/DD/YYYY)	LIMITS
A	<input checked="" type="checkbox"/> COMMERCIAL GENERAL LIABILITY <input type="checkbox"/> CLAIMS-MADE <input checked="" type="checkbox"/> OCCUR  GEN'L AGGREGATE LIMIT APPLIES PER: <input type="checkbox"/> POLICY <input checked="" type="checkbox"/> PRO-JECT <input checked="" type="checkbox"/> LOC <input type="checkbox"/> OTHER:	Y	Y	GL3292138	9/1/2024	9/1/2025	EACH OCCURRENCE \$2,000,000 DAMAGE TO RENTED PREMISES (Ea occurrence) \$300,000 MED EXP (Any one person) \$10,000 PERSONAL & ADV INJURY \$2,000,000 GENERAL AGGREGATE \$4,000,000 PRODUCTS - COMP/OP AGG \$4,000,000 \$
A	<b>AUTOMOBILE LIABILITY</b> <input checked="" type="checkbox"/> ANY AUTO <input type="checkbox"/> OWNED AUTOS ONLY <input type="checkbox"/> SCHEDULED AUTOS <input checked="" type="checkbox"/> HIRED AUTOS ONLY <input checked="" type="checkbox"/> NON-OWNED AUTOS ONLY	Y	Y	CA4544792	9/1/2024	9/1/2025	COMBINED SINGLE LIMIT (Ea accident) \$2,000,000 BODILY INJURY (Per person) \$ BODILY INJURY (Per accident) \$ PROPERTY DAMAGE (Per accident) \$ \$
	<b>UMBRELLA LIAB</b> <input type="checkbox"/> OCCUR <b>EXCESS LIAB</b> <input type="checkbox"/> CLAIMS-MADE DED RETENTION \$						EACH OCCURRENCE \$ AGGREGATE \$ \$
A	<b>WORKERS COMPENSATION AND EMPLOYERS' LIABILITY</b> ANY PROPRIETOR/PARTNER/EXECUTIVE OFFICER/MEMBER EXCLUDED? (Mandatory in NH) If yes, describe under DESCRIPTION OF OPERATIONS below	Y/N	N/A	WC025893618(CA) WC025893619(AOS)	9/1/2024 9/1/2024	9/1/2025 9/1/2025	<input checked="" type="checkbox"/> PER STATUTE <input type="checkbox"/> OTH-ER E.L. EACH ACCIDENT \$2,000,000 E.L. DISEASE - EA EMPLOYEE \$2,000,000 E.L. DISEASE - POLICY LIMIT \$2,000,000
B	Professional Liability			CEO742155602	9/1/2024	9/1/2025	Each Claim/Aggregate \$1,000,000

**DESCRIPTION OF OPERATIONS / LOCATIONS / VEHICLES (ACORD 101, Additional Remarks Schedule, may be attached if more space is required)**  
 RE: Construction Management & Engineering Support Services for Upriver Dam  
 ADDITIONAL INSURED(S): City of Spokane, its officers and employees

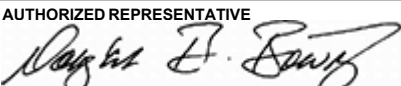
<b>CERTIFICATE HOLDER</b>  City of Spokane 808 W. Spokane Falls Blvd. Spokane WA 99201-3316 USA	<b>CANCELLATION</b>  SHOULD ANY OF THE ABOVE DESCRIBED POLICIES BE CANCELLED BEFORE THE EXPIRATION DATE THEREOF, NOTICE WILL BE DELIVERED IN ACCORDANCE WITH THE POLICY PROVISIONS.  AUTHORIZED REPRESENTATIVE 
--	--

© 1988-2015 ACORD CORPORATION. All rights reserved.

**THIS ENDORSEMENT CHANGES THE POLICY. PLEASE READ IT CAREFULLY.**

## **ADDITIONAL INSURED - OWNERS, LESSEES OR CONTRACTORS - SCHEDULED PERSON OR ORGANIZATION**

This endorsement modifies insurance provided under the following:

COMMERCIAL GENERAL LIABILITY COVERAGE PART

### **SCHEDULE**

<b>Name Of Additional Insured Person(s) Or Organization(s)</b>	<b>Location(s) Of Covered Operations</b>
Any person or organization whom you become obligated to include as an additional insured as a result of any contract or agreement you have entered into.	Per the contract or agreement.
Information required to complete this Schedule, if not shown above, will be shown in the Declarations.	

**A. Section II - Who Is An Insured** is amended to include as an additional insured the person(s) or organization(s) shown in the Schedule, but only with respect to liability for "bodily injury", "property damage" or "personal and advertising injury" caused, in whole or in part, by:

1. Your acts or omissions; or
2. The acts or omissions of those acting on your behalf;

in the performance of your ongoing operations for the additional insured(s) at the location(s) designated above.

However:

1. The insurance afforded to such additional insured only applies to the extent permitted by law; and
2. If coverage provided to the additional insured is required by a contract or agreement, the insurance afforded to such additional insured will not be broader than that which you are required by the contract or agreement to provide for such additional insured.

**B.** With respect to the insurance afforded to these additional insureds, the following additional exclusions apply:

This insurance does not apply to "bodily injury" or "property damage" occurring after:

1. All work, including materials, parts or equipment furnished in connection with such work, on the project (other than service, maintenance or repairs) to be performed by or on behalf of the additional insured(s) at the location of the covered operations has been completed; or
2. That portion of "your work" out of which the injury or damage arises has been put to its intended use by any person or organization other than another contractor or subcontractor engaged in performing operations for a principal as a part of the same project.

C. With respect to the insurance afforded to these additional insureds, the following is added to **Section III – Limits Of Insurance:**

If coverage provided to the additional insured is required by a contract or agreement, the most we will pay on behalf of the additional insured is the amount of insurance:

1. Required by the contract or agreement; or

2. Available under the applicable limits of insurance;  
whichever is less.

This endorsement shall not increase the applicable limits of insurance.

**THIS ENDORSEMENT CHANGES THE POLICY. PLEASE READ IT CAREFULLY.**

## **ADDITIONAL INSURED - OWNERS, LESSEES OR CONTRACTORS - COMPLETED OPERATIONS**

This endorsement modifies insurance provided under the following:

COMMERCIAL GENERAL LIABILITY COVERAGE PART  
PRODUCTS/COMPLETED OPERATIONS LIABILITY COVERAGE PART

### **SCHEDULE**

<b>Name Of Additional Insured Person(s) Or Organization(s)</b>	<b>Location And Description Of Completed Operations</b>
Any person or organization whom you become obligated to include as an additional insured as a result of any contract or agreement you have entered into.	Per the contract or agreement.
Information required to complete this Schedule, if not shown above, will be shown in the Declarations.	

**A. Section II – Who Is An Insured** is amended to include as an additional insured the person(s) or organization(s) shown in the Schedule, but only with respect to liability for "bodily injury" or "property damage" caused, in whole or in part, by "your work" at the location designated and described in the Schedule of this endorsement performed for that additional insured and included in the "products-completed operations hazard".

However:

1. The insurance afforded to such additional insured only applies to the extent permitted by law; and
2. If coverage provided to the additional insured is required by a contract or agreement, the insurance afforded to such additional insured will not be broader than that which you are required by the contract or agreement to provide for such additional insured.

**B.** With respect to the insurance afforded to these additional insureds, the following is added to **Section III – Limits Of Insurance:**

If coverage provided to the additional insured is required by a contract or agreement, the most we will pay on behalf of the additional insured is the amount of insurance:

1. Required by the contract or agreement; or
2. Available under the applicable limits of insurance;

whichever is less.

This endorsement shall not increase the applicable limits of insurance.

POLICY NUMBER:  
GL3292138

COMMERCIAL GENERAL LIABILITY  
CG 20 01 12 19

**THIS ENDORSEMENT CHANGES THE POLICY. PLEASE READ IT CAREFULLY.**

## **PRIMARY AND NONCONTRIBUTORY - OTHER INSURANCE CONDITION**

This endorsement modifies insurance provided under the following:

COMMERCIAL GENERAL LIABILITY COVERAGE PART  
LIQUOR LIABILITY COVERAGE PART  
PRODUCTS/COMPLETED OPERATIONS LIABILITY COVERAGE PART

The following is added to the **Other Insurance** Condition and supersedes any provision to the contrary:

### **Primary And Noncontributory Insurance**

This insurance is primary to and will not seek contribution from any other insurance available to an additional insured under your policy provided that:

**(1)** The additional insured is a Named Insured under such other insurance; and

**(2)** You have agreed in writing in a contract or agreement that this insurance would be primary and would not seek contribution from any other insurance available to the additional insured.

## WAIVER OF TRANSFER OF RIGHTS OF RECOVERY AGAINST OTHERS TO US (WAIVER OF SUBROGATION)

This endorsement modifies insurance provided under the following:

COMMERCIAL GENERAL LIABILITY COVERAGE PART  
ELECTRONIC DATA LIABILITY COVERAGE PART  
LIQUOR LIABILITY COVERAGE PART  
POLLUTION LIABILITY COVERAGE PART DESIGNATED SITES  
POLLUTION LIABILITY LIMITED COVERAGE PART DESIGNATED SITES  
PRODUCTS/COMPLETED OPERATIONS LIABILITY COVERAGE PART  
RAILROAD PROTECTIVE LIABILITY COVERAGE PART  
UNDERGROUND STORAGE TANK POLICY DESIGNATED TANKS

### SCHEDULE

**Name Of Person(s) Or Organization(s):**

Pursuant to applicable written contract or agreement you enter into.

Information required to complete this Schedule, if not shown above, will be shown in the Declarations.

The following is added to Paragraph **8. Transfer Of Rights Of Recovery Against Others To Us** of **Section IV - Conditions**:

We waive any right of recovery against the person(s) or organization(s) shown in the Schedule above because of payments we make under this Coverage Part. Such waiver by us applies only to the extent that the insured has waived its right of recovery against such person(s) or organization(s) prior to loss. This endorsement applies only to the person(s) or organization(s) shown in the Schedule above.

**WAIVER OF OUR RIGHT TO RECOVER FROM OTHERS ENDORSEMENT**

This endorsement changes the policy to which it is attached effective on inception date of the policy unless a different date is indicated below.

(The following "attaching clause" need be completed only when this endorsement is issued subsequent to preparation of the policy).

This endorsement, effective 12:01 AM 09/01/2024 forms a part of Policy No. WC025893619(AOS)

Issued to **McMillen, Inc**

By NATIONAL UNION FIRE INSURANCE COMPANY OF PITTSBURGH, PA.

We have the right to recover our payments from anyone liable for an injury covered by this policy. We will not enforce our right against the person or organization named in the Schedule. This agreement applies only to the extent that you perform work under a written contract that requires you to obtain this agreement from us.

This agreement shall not operate directly or indirectly to benefit any one not named in the Schedule.

**Schedule**

ANY PERSON OR ORGANIZATION TO WHOM YOU BECOME  
OBLIGATED TO WAIVE YOUR RIGHTS OF RECOVERY  
AGAINST, UNDER ANY CONTRACT OR AGREEMENT YOU ENTER  
INTO PRIOR TO THE OCCURRENCE OF LOSS.

This form is not applicable in California, Kentucky, New Hampshire, New Jersey, North Dakota, Ohio, Tennessee, Texas, Utah, or Washington. This form is not applicable in Missouri when there is a construction code on the policy and there is Missouri premium or exposure.

WC 00 03 13  
(Ed. 04/84)

Countersigned by \_\_\_\_\_



**Authorized Representative**



**BLANKET WAIVER OF OUR RIGHT TO RECOVER FROM OTHERS ENDORSEMENT**

This endorsement changes the policy to which it is attached effective on the inception date of the policy unless a different date is indicated below.

(The following "attaching clause" need be completed only when this endorsement is issued subsequent to preparation of the policy).

This endorsement effective 12:01 AM 09/01/2024 forms a part of Policy No. WC025893618(CA)

Issued to McMillen, Inc

By NATIONAL UNION FIRE INSURANCE COMPANY OF PITTSBURGH, PA.

We have a right to recover our payments from anyone liable for an injury covered by this policy. We will not enforce our right against any person or organization with whom you have a written contract that requires you to obtain this agreement from us, as regards any work you perform for such person or organization.

The additional premium for this endorsement shall be 2.00 % of the total estimated workers compensation premium for this policy.



**ENDORSEMENT**

This endorsement, effective 12:01 A.M. 09/01/2024 forms a part of

Policy No. **CA4544792** issued to **McMillen, Inc**

by NATIONAL UNION FIRE INSURANCE COMPANY OF PITTSBURGH, PA

**THIS ENDORSEMENT CHANGES THE POLICY. PLEASE READ IT CAREFULLY.**

**ADDITIONAL INSURED - WHERE REQUIRED UNDER CONTRACT OR AGREEMENT**

*This endorsement modifies insurance provided under the following:*

BUSINESS AUTO COVERAGE FORM

SCHEDULE

**ADDITIONAL INSURED:**

Any person or organization for whom you are contractually bound to provide Additional Insured status but only to the extent of such person's or organization's liability arising out of the use of a covered "auto".

**I. SECTION II - COVERED AUTOS LIABILITY COVERAGE, A. Coverage, 1. - Who Is Insured, is amended to add:**

d. Any person or organization, shown in the schedule above, to whom you become obligated to include as an additional insured under this policy, as a result of any contract or agreement you enter into which requires you to furnish insurance to that person or organization of the type provided by this policy, but only with respect to liability arising out of use of a covered "auto". However, the insurance provided will not exceed the lesser of:

- (1) The coverage and/or limits of this policy, or
- (2) The coverage and/or limits required by said contract or agreement.



\_\_\_\_\_  
AUTHORIZED REPRESENTATIVE

**ENDORSEMENT**

This endorsement, effective 12:01 A.M. 09/01/2024 forms a part of

policy No. CA4544792 issued to **McMillen, Inc**

by NATIONAL UNION FIRE INSURANCE COMPANY OF PITTSBURGH, PA

**THIS ENDORSEMENT CHANGES THE POLICY. PLEASE READ IT CAREFULLY.**

**INSURANCE PRIMARY AS TO CERTAIN ADDITIONAL INSURED**

*This endorsement modifies insurance provided under the following:*

BUSINESS AUTO COVERAGE FORM

**Section IV - Business Auto Conditions, B., General Conditions, 5., Other Insurance, c.,** is amended by the addition of the following sentence:

The insurance afforded under this policy to an additional insured will apply as primary insurance for such additional insured where so required under an agreement executed prior to the date of accident. We will not ask any insurer that has issued other insurance to such additional insured to contribute to the settlement of loss arising out of such accident.

All other terms and conditions remain unchanged.



Authorized Representative or  
Countersignature (in States Where  
Applicable)

**ENDORSEMENT**

This endorsement, effective 12:01 A.M. 09/01/2024 forms a part of

policy No. CA4544792 issued to McMillen, Inc

by NATIONAL UNION FIRE INSURANCE COMPANY OF PITTSBURGH, PA

**THIS ENDORSEMENT CHANGES THE POLICY. PLEASE READ IT CAREFULLY.**

**WAIVER OF TRANSFER OF RIGHTS OF RECOVERY AGAINST OTHERS TO US**

*This endorsement modifies insurance provided under the following:*

**BUSINESS AUTO COVERAGE FORM**

**Section IV - Business Auto Conditions, A. - Loss Conditions, 5. - Transfer of Rights of Recovery Against Others to Us**, is amended to add:

However, we will waive any right of recover we have against any person or organization with whom you have entered into a contract or agreement because of payments we make under this Coverage Form arising out of an "accident" or "loss" if:

- (1) The "accident" or "loss" is due to operations undertaken in accordance with the contract existing between you and such person or organization; and
- (2) The contract or agreement was entered into prior to any "accident" or "loss".

No waiver of the right of recovery will directly or indirectly apply to your employees or employees of the person or organization, and we reserve our rights or lien to be reimbursed from any recovery funds obtained by any injured employee.



\_\_\_\_\_  
AUTHORIZED REPRESENTATIVE



**Agenda Sheet for City Council:**

**Committee:** PIES **Date:** 10/21/2024

**Committee Agenda type:** Consent

**Date Rec'd** 10/22/2024

**Clerk's File #** OPR 2014-0060

**Cross Ref #** RES 2014-0131

**Project #**

**Council Meeting Date:** 11/04/2024

<b>Submitting Dept</b>	SOLID WASTE DISPOSAL	<b>Bid #</b>	
------------------------	----------------------	--------------	--

<b>Contact Name/Phone</b>	CHRIS AVERYT 625-6540	<b>Requisition #</b>	NA
---------------------------	-----------------------	----------------------	----

<b>Contact E-Mail</b>	CAVERYT@SPOKANECITY.ORG		
-----------------------	-------------------------	--	--

<b>Agenda Item Type</b>	Contract Item		
-------------------------	---------------	--	--

<b>Council Sponsor(s)</b>	BWILKERSON JBINGLE KKLITZKE		
---------------------------	-----------------------------	--	--

<b>Agenda Item Name</b>	4490-CITY/COUNTY DISPOSAL INTERLOCAL AGREEMENT AMENDMENT NO. 5		
-------------------------	--	--	--

**Agenda Wording**

Amendment No. 5 to the Interlocal Agreement (ILA) between the City of Spokane and Spokane County for transfer and disposal services at the City's Waste to Energy Facility (WTE).

**Summary (Background)**

In 2014, an ILA outlining the transfer and disposal of solid waste between the City and County was entered into. In 2017, the ILA was amended to adjust the County's disposal rate, eliminate the termination clause and amend the term to five years with five 1-year extensions. This amendment adds up to (5) one year automatic renewals, allows the County to pursue a separate contract for bypass waste and adds language to address trailer damage liability and Flow Control.

Lease? NO Grant related? NO Public Works? NO

**Fiscal Impact**

Approved in Current Year Budget? N/A

Total Cost \$ 0

Current Year Cost \$

Subsequent Year(s) Cost \$

**Narrative**

This is a revenue generating Interlocal Agreement that was planned for in the Solid Waste Disposal budget.

**Amount**

**Budget Account**

Revenue	\$ 8,000,000.00	# 4490-44110-37052-34379
Select	\$	#
Select	\$	#
Select	\$	#
	\$	#
	\$	#



**Continuation of Wording, Summary, Approvals, and Distribution**

**Agenda Wording**

**Summary (Background)**

**Approvals**

<b><u>Dept Head</u></b>	AVERYT, CHRIS
<b><u>Division Director</u></b>	FEIST, MARLENE
<b><u>Accounting Manager</u></b>	ALBIN-MOORE, ANGELA
<b><u>Legal</u></b>	SCHOEDEL, ELIZABETH
<b><u>For the Mayor</u></b>	PICCOLO, MIKE

**Additional Approvals**

<b><u>PURCHASING</u></b>	PRINCE, THEA

**Distribution List**

	mdorgan@spokanecity.org
jsalstrom@spokanecity.org	tprince@spokanecity.org
caveryt@spokanecity.org	eschoedel@spokanecity.org

## Committee Agenda Sheet

### Public Infrastructure, Environment & Sustainability Committee

<b>Committee Date</b>	October 21, 2024
<b>Submitting Department</b>	Solid Waste Disposal
<b>Contact Name</b>	Chris Averyt
<b>Contact Email &amp; Phone</b>	<a href="mailto:caveryt@spokanecity.org">caveryt@spokanecity.org</a> , 625-6540
<b>Council Sponsor(s)</b>	Wilkerson, Bingle, Klitzke
<b>Select Agenda Item Type</b>	<input checked="" type="checkbox"/> Consent <input type="checkbox"/> Discussion    Time Requested:
<b>Agenda Item Name</b>	Amendment #5 to the Disposal Interlocal Agreement between the City of Spokane and Spokane
<b>Proposed Council Action</b>	<input checked="" type="checkbox"/> Approval to proceed to Legislative Agenda <input type="checkbox"/> Information Only
<b>Summary (Background)</b>  *use the Fiscal Impact box below for relevant financial information	<p>In 2014, under Resolution No. 14-0131 and OPR 2014-0060, an Interlocal Agreement (ILA) outlining the transfer and disposal of solid waste between the City and County was finalized. The ILA laid the foundation for a smooth transition of the management of the Regional Solid Waste System from the City to the County, effective November 17, 2014. The City and County have worked together very effectively under the terms of that ILA, providing reliable solid waste transfer and disposal services to all the member jurisdictions of the Regional Solid Waste System.</p> <p>In 2017, the ILA was amended to adjust the disposal rate for the County, eliminate the termination clause and amend the term to five years with five 1-year extension options that will renew automatically on September 1<sup>st</sup> each year. The first 1-year extension began automatically on September 1, 2023.</p> <p>The provisions of this ILA amendment/extension include:</p> <ul style="list-style-type: none"> <li>• Adds up to (5) one-year automatic renewals.</li> <li>• Allows the County to pursue a separate contract for bypass waste.</li> <li>• Adds language to address trailer damage liability and Flow Control.</li> </ul>
<b>Fiscal Impact</b>	
<b>Approved in current year budget?</b> <input type="checkbox"/> Yes <input type="checkbox"/> No <input type="checkbox"/> N/A	
Total Cost: <u>Anticipated annual revenue of \$8,000,000.00</u>	
Current year cost:	
Subsequent year(s) cost:	
<b>Narrative:</b> <u>This is a revenue generating interlocal agreement that was planned for in the Solid Waste Disposal budget.</u>	
<b>Funding Source</b> <input type="checkbox"/> One-time <input type="checkbox"/> Recurring <input checked="" type="checkbox"/> N/A	
Specify funding source: Select Funding Source*	
Is this funding source sustainable for future years, months, etc? Yes	
<b>Expense Occurrence</b> <input type="checkbox"/> One-time <input type="checkbox"/> Recurring <input checked="" type="checkbox"/> N/A	
Other budget impacts: (revenue generating, match requirements, etc.) Revenue Generating	

**Operations Impacts** (If N/A, please give a brief description as to why)

- What impacts would the proposal have on historically excluded communities?  
Public works services and projects are designed to serve all citizens and businesses. We strive to offer a consistent level of service to all, to distribute public investment throughout the community and to respond to gaps in services identified in various City plans.
- How will data be collected, analyzed, and reported concerning the effect of the program/policy by racial, ethnic, gender identity, national origin, income level, disability, sexual orientation, or other existing disparities?  
N/A
- How will data be collected regarding the effectiveness of this program, policy, or product to ensure it is the right solution?  
Public Works follows the City's established procurement and public works bidding regulations and policies to bring items forward, and then uses contract management best practices to ensure desired outcomes and regulatory compliance.
- Describe how this proposal aligns with current City Policies, including the Comprehensive Plan, Sustainability Action Plan, Capital Improvement Program, Neighborhood Master Plans, Council Resolutions, and others?  
This work is consistent with annual budget strategies to limit costs and approved projects in the 6-year CIP.

**Council Subcommittee Review**

- Please provide a summary of council subcommittee review. If not reviewed by a council subcommittee, please explain why not.

Not applicable





**City of Spokane**  
**INTERLOCAL AGREEMENT FOR SOLID  
WASTE AMENDMENT #5**

**THIS INTERLOCAL AGREEMENT AMENDMENT #5** is between the CITY OF SPOKANE, a Washington State municipal corporation, as "City," and SPOKANE COUNTY, a political subdivision of the State of Washington, "County", whose address for the transaction of business is 1116 West Broadway Avenue, Spokane, Washington 99260. Together referenced as the "Parties".

*WHEREAS, the Parties entered into an Interlocal Agreement Between the City of Spokane and Spokane County Regarding Transfer and Disposal of Solid Waste, (Agreement) on February 19, 2014 and subsequently amended on January 21, 2015 to provide an early buy out for the purchase of the Transfer Stations, on June 22, 2015 to provide for all by-pass waste delivered to the Waste-To-Energy Facility under current contract, and August 15, 2017 to provide an extension to the term of the agreement, update disposal rates and the termination clause; and*

*WHEREAS, the Parties agree to amend the Interlocal Agreement to add back the renewal paragraph, which was inadvertently deleted in the 2023 amendment #4 and to reflect a change in the date of the renewal from September 2<sup>nd</sup> to November 17<sup>th</sup> of each additional, thus the original Interlocal Agreement needs to be formally Amended by this written document; and*

*WHEREAS, the Parties agree to amend the Interlocal Agreement to reflect a change in the County Disposal Rate for solid waste and by-pass waste and other items in Section 4, Terms and*

*NOW, THEREFORE, in consideration of these terms, the parties mutually agree as follows:*

**A. CONTRACT DOCUMENTS.**

The Interlocal Agreement, dated February 19, 2014, any previous amendments, addendums and / or extensions / renewals thereto, are incorporated by reference into this document as though written in full and shall remain in full force and effect except as provided herein.

**B. EFFECTIVE DATE.**

This Interlocal Agreement Amendment shall become effective when fully executed and shall end November 17, 2025.

**C. AMENDMENT.**

A. Section No. 3 shall read as follows:

**SECTION NO. 3: DURATION**

*This Agreement shall automatically extend for up to five (5) additional one-year terms commencing November 17, 2025 and running through November 16th of the following year UNLESS one party gives notice to the other party six months prior to November 17th of any*

*contract year that they do not intend to extend for an additional one(1) year term, in which case the Agreement will terminate on November 17th.*

B. Section No. 4(C)(1) is amended to read as follows:

Delivery of Solid Waste to City Waste To Energy Facility. The City shall inform the County of the monthly tonnage that the City would like to receive from the County in order to efficiently operate the WTE. The County shall pay the County Disposal Rate as provided for in Section 4(H) of this Agreement. While both parties intend to supply the necessary tonnage to support operations of the City Waste to Energy Facility and County Transfer Stations, both the County and the City reserve the right to deliver waste to each respective facility at their sole discretion, provided it is within terms of the Flow Control Ordinance. The County may enter into separate agreements regarding waste not delivered to the WTE. The County shall notify the City in writing at least three (3) months in advance of starting such an agreement.

C. Section No. 4(M) is amended to read as follows:

M. Non-processible Waste:

The City shall be responsible for identifying and disposing of any non-processible waste delivered to the Waste to Energy Facility, excluding loads received from the County transfer hauls. The City and the County further agree, that upon request of the City during times when the Waste to Energy Facility is unavailable to process waste, the County agrees to load waste from one or both County Transfer Stations into containers and deliver to an alternate designated system disposal site.

Replacement or Repair of Containers for By-pass Transportation. The County and its subcontractors, shall be liable for the repair or replacement of Containers/Trailers and Vehicles to the extent such is necessary because of the negligence of the County or County's Transfer Stations contracted operator, including but not limited to, overloading or improper loading of Equipment. If damage occurs to the equipment, the disposal provider for By-pass Waste will document the damage and send such documentation to the responsible Party. Once repairs are completed, disposal provider for By-pass Waste will invoice the responsible Party directly for reimbursement.

If a container or trailer is delivered by the County to the disposal provider for By-pass waste with external evidence (such as smoke or extreme heat) that the container or trailer might contain Unacceptable Waste, or might reasonably contain Unacceptable Waste and the disposal provider for By-pass waste takes steps it believes is necessary to protect its employees and the public from potential hazard, the County, or its subcontractors, is responsible for all costs and liability associated with managing Unacceptable Waste within the container.

"Unacceptable Waste" means Hazardous Waste and any waste, the acceptance and handling of which would cause a violation of any solid waste facility permits or applicable law.

D. Section 4(D) is amended to read as follows:

The County shall maintain, and enforce within its jurisdiction, its Flow Control Ordinance for the duration of this Agreement, so long as the Flow Control Ordinance is legally enforceable. During the term of this Agreement, subject to the exceptions currently in effect contained in its Flow Control Ordinance, the County designates the Waste To Energy Facility to be a designated system disposal site for solid waste at all times the Facility is in operation. The County may designate other facilities as system disposal sites.

E. Sections 4(E) and 4(F) are deleted.

F. 4H of the Agreement is hereby amended to read as follows:

**H. County Disposal Rate:**

Solid Waste Delivered to WTE: For the period of Amendment #5, the County shall pay to the City a price per ton for each ton of solid waste delivered from the Transfer Stations to the Waste to Energy Facility by the County based on the annual rate adjustment below with base year pricing provided in Amendment #4.

Waste Delivered using City’s contract for non-processible waste: For the period of Amendment #4, the County shall pay to the City the per ton price according to the terms in Contract OPR 2023-1043 for any solid waste delivered by the County to City’s contract vendor from the Transfer Stations.

On January 1<sup>st</sup> of each year following the initial one (1) year term of this Agreement in 2024, the CITY will adjust the County Disposal Rate to reflect increases in the United States Department of Labor, Bureau of Labor Statistics, West-Size Class B/C, Consumer Price Index, All Items for All Urban Consumers (CPI-U) (the "Index"). The adjustment factor for computing annual rate adjustments shall be computed by dividing the Index number for October of the just-completed year by the Index number for October of the previous year. In the event the Index number stays the same or decreases, no rate adjustment will be made, and the next rate adjustment shall not occur until the Index number increases to a number exceeding the highest previous Index number and shall be computed using the previous highest Index number.

*Example Calculation of Annual Rate Adjustments:*

	<i>INDEX</i>	<i>ADJUST FACTOR</i>	<i>COUNTY DISPOSAL RATE</i>
<i>Base Tr. N</i>	<i>125</i>		<i>65.00</i>
<i>N+1</i>	<i>128.844</i>	<i>1.030752</i>	<i>67.44</i>
<i>N+2</i>	<i>133.315</i>	<i>1.034710</i>	<i>69.78</i>
<i>N+3*</i>	<i>132.474</i>	<i>No change</i>	<i>69.78</i>
<i>N+4**</i>	<i>133</i>	<i>No change</i>	<i>69.78</i>
<i>N+5</i>	<i>137.748</i>	<i>1.033252</i>	<i>72.10</i>
<i>N+6</i>	<i>140.054</i>	<i>1.1016741</i>	<i>73.31</i>
<i>* No change – Index decreased</i>			
<i>** No charge – Index did not exceed highest previous Index</i>			

IN WITNESS WHEREOF, in consideration of the terms, conditions and covenants contained, or attached and incorporated and made a part, the parties have executed this Contract Amendment by having legally binding representatives affix their signatures below.

**PASSED AND ADOPTED** this \_\_\_\_\_ day of \_\_\_\_\_, 2024.

BOARD OF COUNTY COMMISSIONERS  
OF SPOKANE COUNTY, WASHINGTON

\_\_\_\_\_  
MARY L. KUNEY, CHAIR

ATTEST:

\_\_\_\_\_  
Ginna Vasquez  
Clerk of the Board

\_\_\_\_\_  
JOSH KERNS, VICE-CHAIR

\_\_\_\_\_  
AL FRENCH, COMMISSIONER

\_\_\_\_\_  
AMBER WALDREF, COMMISSIONER

\_\_\_\_\_  
CHRIS JORDAN, COMMISSIONER

Approved as to form:

\_\_\_\_\_  
Deputy Civil Prosecuting Attorney

CITY OF SPOKANE

Attest:

By \_\_\_\_\_  
Signature Date

\_\_\_\_\_  
City Clerk

\_\_\_\_\_  
Type or Print Name

\_\_\_\_\_  
Title

Approved as to form:

\_\_\_\_\_  
Assistant City Attorney

**Attachments that are part of this Agreement:**

N/A

U2024-091d



**Agenda Sheet for City Council:**

**Committee:** PIES **Date:** 10/21/2024

**Committee Agenda type:** Consent

**Date Rec'd** 10/22/2024

**Clerk's File #** OPR 2023-1043

**Cross Ref #**

**Project #**

**Council Meeting Date:** 11/04/2024

<b>Submitting Dept</b>	SOLID WASTE DISPOSAL	<b>Bid #</b>	RFP 5817-23
------------------------	----------------------	--------------	-------------

<b>Contact Name/Phone</b>	CHRIS AVERYT 625-6540	<b>Requisition #</b>	N/A
---------------------------	-----------------------	----------------------	-----

<b>Contact E-Mail</b>	CAVERYT@SPOKANECITY.ORG		
-----------------------	-------------------------	--	--

<b>Agenda Item Type</b>	Contract Item		
-------------------------	---------------	--	--

<b>Council Sponsor(s)</b>	BWILKERSON JBINGLE KKLITZKE		
---------------------------	-----------------------------	--	--

<b>Agenda Item Name</b>	4490 CONTRACT AMENDMENT FOR THE TRANSPORTATION AND DISPOSAL OF		
-------------------------	--	--	--

**Agenda Wording**

Contract amendment with Waste Management of Washington, Inc. (Kirkland, WA) for the transportation and disposal of bypass waste from the Waste to Energy Facility and County Transfer Stations.

**Summary (Background)**

Waste Management of Washington, Inc. was awarded a five (5) year ash/bypass hauling contract with the option of one additional five year renewal, which commenced on Nov. 17, 2023. This contract amendment adds a provision and pricing for Waste Management to provide hauling directly from the County owned transfer stations to the Adams County Landfill. The resulting cost to the contract will be covered by the County and not result in any additional expense to the City.

Lease? NO Grant related? NO Public Works? NO

**Fiscal Impact**

Approved in Current Year Budget? N/A

Total Cost \$ 0

Current Year Cost \$

Subsequent Year(s) Cost \$

**Narrative**

This is an amendment to a contractual services contract. Spokane County will be covering any additional costs resulting in this amendment so the expense budget will not be impacted.

<b>Amount</b>	<b>Budget Account</b>
---------------	-----------------------

Neutral \$	#
Select \$	#
Select \$	#
Select \$	#
\$	#
\$	#



## Committee Agenda Sheet

### Public Infrastructure, Environment & Sustainability Committee

<b>Committee Date</b>	October 21, 2024
<b>Submitting Department</b>	Solid Waste Disposal
<b>Contact Name</b>	Chris Averyt
<b>Contact Email &amp; Phone</b>	<a href="mailto:caveryt@spokanecity.org">caveryt@spokanecity.org</a> , 625-6540
<b>Council Sponsor(s)</b>	Wilkerson, Bingle, Klitzke
<b>Select Agenda Item Type</b>	<input checked="" type="checkbox"/> Consent <input type="checkbox"/> Discussion    Time Requested:
<b>Agenda Item Name</b>	Contract amendment for the transportation and disposal of bypass and non-processible waste from the Waste to Energy Facility.
<b>Proposed Council Action</b>	<input checked="" type="checkbox"/> Approval to proceed to Legislative Agenda <input type="checkbox"/> Information Only
<b>Summary (Background)</b>  *use the Fiscal Impact box below for relevant financial information	<p>On March 20, 2023 bidding closed on RFP 5817-23 for transportation and disposal of bypass and non-processible waste from the Waste to Energy Facility and County Transfer Stations. Responses were received from Waste Connections (Vancouver, WA), Waste Management of Washington, Inc. (Kirkland, WA) and Regional Disposal Company (Redmond, WA), of which Waste Management was the preferred bidder.</p> <p>The initial contract award was for five (5) years with the option of one (1) additional five (5) year period, and began on Nov. 17, 2023.</p> <p>The provisions of this amendment include:</p> <ul style="list-style-type: none"> <li>• Adding a provision and pricing for Waste Management to provide hauling directly from the County owned transfer stations to Adams County Landfill.</li> <li>• The County will be self-operating the transfer stations beginning on November 15<sup>th</sup>, 2024. This has changed their hauling contracts, and they wish for Waste Management to perform the service going forward.</li> <li>• The County covers this cost and does not add any additional expense for the City.</li> </ul>
<p><b>Fiscal Impact</b></p> <p><b>Approved in current year budget?</b>    <input type="checkbox"/> Yes    <input type="checkbox"/> No    <input checked="" type="checkbox"/> N/A</p> <p>Total Cost: <u>0</u></p> <p>    Current year cost:</p> <p>    Subsequent year(s) cost:</p> <p><b>Narrative:</b> <u>This is an amendment to a contractual services contract. The County will be covering any additional costs, so this will not impact the expense budget.</u></p> <p><b>Funding Source</b>    <input type="checkbox"/> One-time    <input checked="" type="checkbox"/> Recurring    <input checked="" type="checkbox"/> N/A</p> <p>Specify funding source: Program revenue</p> <p>Is this funding source sustainable for future years, months, etc? Yes</p> <p><b>Expense Occurrence</b>    <input type="checkbox"/> One-time    <input type="checkbox"/> Recurring    <input checked="" type="checkbox"/> N/A</p> <p>Other budget impacts: (revenue generating, match requirements, etc.)</p>	

**Operations Impacts** (If N/A, please give a brief description as to why)

- What impacts would the proposal have on historically excluded communities?  
Public works services and projects are designed to serve all citizens and businesses. We strive to offer a consistent level of service to all, to distribute public investment throughout the community and to respond to gaps in services identified in various City plans.
- How will data be collected, analyzed, and reported concerning the effect of the program/policy by racial, ethnic, gender identity, national origin, income level, disability, sexual orientation, or other existing disparities?  
N/A
- How will data be collected regarding the effectiveness of this program, policy, or product to ensure it is the right solution?  
Public Works follows the City's established procurement and public works bidding regulations and policies to bring items forward, and then uses contract management best practices to ensure desired outcomes and regulatory compliance.
- Describe how this proposal aligns with current City Policies, including the Comprehensive Plan, Sustainability Action Plan, Capital Improvement Program, Neighborhood Master Plans, Council Resolutions, and others?  
This work is consistent with annual budget strategies to limit costs and approved projects in the 6-year CIP.

**Council Subcommittee Review**

- Please provide a summary of council subcommittee review. If not reviewed by a council subcommittee, please explain why not.

Not applicable



**FIRST AMENDMENT OF SERVICE CONTRACT FOR TRANSPORT AND DISPOSAL OF  
BYPASS AND NON-PROCESSIBLE WASTE**

**Between  
CITY OF SPOKANE, WASHINGTON  
And  
WASTE MANAGEMENT OF WASHINGTON, INC.**

This FIRST AMENDMENT OF SERVICE CONTRACT FOR TRANSPORT AND DISPOSAL OF BYPASS AND NON-PROCESSIBLE WASTE (this “**First Amendment**”) is entered into as of \_\_\_\_\_, 2024 (the “**Effective Date**”) by and between WASTE MANAGEMENT OF WASHINGTON, INC., a Delaware corporation (“the Company”) and City of Spokane Washington, a municipal corporation created under the laws of the State of Washington (City). The parties shall be collectively referred to herein as the “**Parties**” and individually as a “**Party**”, unless specifically identified otherwise.

**RECITALS**

**WHEREAS** the Company and City are Parties to that certain Service Contract Related to Transportation and Disposal of Bypass Waste and Non-Processible Waste, effective November 17, 2023 (OPR 2023-1043) (the “**Contract**”); and

**WHEREAS** in 2014, Spokane County elected to operate the two County Owned Transfer Stations; and

**WHEREAS**, Spokane County has now elected to directly manage the solid waste delivered thereto instead of contracting with a third-party operator for such services; and

**WHEREAS**, the Parties desire to amend the Contract to address Spokane County’s operational changes at the two County Transfer Stations and the compensation payable by the City to the Company; and

**WHEREAS**, the Parties now desire to amend the Contract revise certain terms and conditions set forth thereunder, on the terms and conditions contained herein. Capitalized terms used herein but not defined shall have the meanings set forth in the Contract.

**CONTRACT**

**NOW THEREFORE**, in consideration of the mutual covenants and promises contained herein, the receipt and sufficiency of which are hereby acknowledged, the Parties mutually agree as follows:

1. SECTION 1.1. DEFINITIONS.

- a. “C&D Waste” shall be deleted in its entirety and replaced with the following:

“C&D Waste” means dry wastes resulting from construction, renovation, remodeling, repair or demolition operations of buildings, structures, road building or from land clearing activities.”

b. Receiving Facility” shall be deleted in its entirety and replaced with the following:

“Receiving Facility” means the two (2) Spokane County Transfer Stations. Additional properties may be mutually agreed to in writing by both Parties.

2. SECTION 5.1.(B) shall be amended to read as follows:

(B) Bypass Waste.

- (1) The County or the County’s Representative shall be responsible for loading Bypass Waste at the Transfer Stations into Containers provided by the Company in compliance with all Applicable Laws and other Contract Standards, including but not limited to U.S. Department of Transportation requirements.
- (2) The Company or the Company’s Subcontractor shall be responsible for (i) transportation and delivery of accepted loaded Containers of Bypass Waste from the two County Transfer Stations to the Disposal Site; (ii) tipping the Containers of Bypass Waste at the Disposal Site; and (iii) transportation of empty Containers and chassis from the Disposal Site to the two County Transfer Stations.
- (3) The City shall have the option for the County or the County’s Representative to transport and deliver loaded containers of C&D Waste separated from the Bypass Waste from the Transfer Stations directly to the C&D Disposal Site.

3. SECTION 5.1.(C) shall be deleted in its entirety.

4. SECTION 5.1(F) shall be deleted in its entirety and replaced with the following:

(F) Capacity. The Company shall be solely responsible for providing sufficient capacity to receive, transport and dispose of Bypass Waste and receive and dispose Non-Processible Waste in accordance with this Contract. The Company or its Subcontractor may accept, or allow for the acceptance of, materials from other sources at the Disposal Sites; provided that acceptance of such materials does not interfere with providing services in accordance with this Contract. The Company shall be solely responsible for all losses, damages, costs, charges, expenses, judgements or any liabilities whatsoever resulting from the acceptance of materials from other sources at the Disposal Sites.

5. SECTION 5.2 BYPASS WASTE AND NON-PROCESSIBLE WASTE TRANSPORT AND DISPOSAL GUARANTEE shall be amended to revise the reference to “Receiving Yard” in the second sentence of subsection (2) to “Receiving Facility.”

6. SECTION 5.5 SPILLAGE, LEAKAGE, LITTER, ODOR AND OTHER NUISANCES shall be amended to delete subsection (6) in its entirety.

7. SECTION 6.1 PERIODIC REPORTS shall be amended to delete the last paragraph of the section and replace it with the following:

“The City acknowledges and agrees that documentation regarding loaded Containers or Trailers of Bypass Waste picked up by the Company or the Company’s Subcontractor from the Transfer Stations shall be maintained by the County or the County’s Representative.”

8. SECTION 7.2. DISPOSAL CHARGE, shall be deleted in its entirety and replaced with the following:

Except for any costs resulting from or associated with Unacceptable Waste, the Service Fee is an all-inclusive set fee per ton. The Service Fee shall be calculated by multiplying the total number of tons of Contract Waste accepted by the Company in a calendar month by the applicable per-ton price for the Contract Waste. The Service Fee shall be inclusive of all costs associated with transportation (as applicable to the Contract Services provided by the Company), disposal, equipment, fees, maintenance, and any other costs necessary for the Company to perform the Contract Services and to produce the deliverables under the Contract. The Service Fee shall be based on the weights recorded at the inbound scales at the Disposal Site. The per-ton prices for Bypass Waste and Non-Processible Waste is as set forth below.

Transfer Station Site	Bypass Waste
Colbert	\$63.82 / ton
Valley	\$63.82 / ton

Site	Bypass Waste and Non-Processible Waste
WTE	\$58.95 / ton

9. **Full Force and Effect.** Except as otherwise provided in this First Amendment, all other terms and provisions of the Agreement, as amended, shall remain in full force and effect.
10. **Counterparts; Signatures.** This First Amendment may be executed in two (2) or more counterparts, each of which shall be deemed an original, but all of which together shall constitute one and the same instrument. Signatures transmitted electronically shall be deemed valid execution of this First Amendment and binding on the Parties.

**IN WITNESS WHEREOF**, the Parties enter into this First Amendment as of the dates set forth below. Each person signing this First Amendment represents and warrants that he or she has been duly authorized to enter into this First Amendment by the Party on whose behalf it is indicated that the person is signing.

**THE CITY OF SPOKANE, WASHINGTON**

**WASTE MANAGEMENT OF  
WASHINGTON, INC.**

By: \_\_\_\_\_

By: \_\_\_\_\_

Name: \_\_\_\_\_

Name: Jason Rose

Title: \_\_\_\_\_

Title: President

Date: \_\_\_\_\_

Date: \_\_\_\_\_

**ATTEST:**

By: \_\_\_\_\_

Title: \_\_\_\_\_

**APPROVED AS TO FORM:**

By: \_\_\_\_\_

Title: \_\_\_\_\_



< Business Lookup

License Information:

[New search](#) [Back to results](#)

**Entity name:** WASTE MANAGEMENT OF WASHINGTON, INC.

**Business name:** WASTE MANAGEMENT OF SPOKANE # 2681

**Entity type:** [Profit Corporation](#)

**UBI #:** 601-415-286

**Business ID:** 001

**Location ID:** 0023

**Location:** Active

**Location address:** 11321 E INDIANA RD  
SPOKANE VALLEY WA 99206-5133

**Mailing address:** 720 4TH AVE  
STE 400  
KIRKLAND WA 98033-8136

**Excise tax and reseller permit status:** [Click here](#)

**Secretary of State status:** [Click here](#)

Endorsements

Endorsements held at this location	License #	Count	Details	Status	Expiration date	First issuance date
<a href="#">Spokane General Business - Non-Resident</a>	T12003743BUS			Active	May-31-2025	Oct-15-2012

Governing People May include governing people not registered with Secretary of State

Governing people	Title
BENNETT, JEFF R	ASSISTANT TREASURER
CARROLL, JOHN A.	CONTROLLER
CASSIN, JOSEPH J	Vice President
GOMEZ, JUAN V	Vice President, ASSISTANT SECRETARY
KHAJETOORIANS, ASTEGHIK	ASSISTANT SECRETARY
LEWIS, AME C	ASSISTANT SECRETARY
LOCKETT, MARK A.	Vice President, ASSISTANT TREASURER
NAGY, LESLIE K.	Vice President, ASSISTANT TREASURER
ROSE, JASON S.	President, Vice President, CHIEF FINANCIAL OFFICER AND CONTROLLER
TIPPY, COURTNEY A	Vice President, Secretary
TIPPY, COURTNEY A.	
WASTE MANAGEMENT HOLDINGS, INC.	
WILSON, JAMES A	Vice President
WINSTON, ADAM C	Vice President

< Page 1 of 2 >

Registered Trade Names

Registered trade names	Status	First issued
ADAMS COUNTY REGIONAL LANDFILL	Active	May-15-2024
BREM-AIR DISPOSAL	Active	Oct-29-2001
CASCADE RECYCLING CENTER	Active	Sep-06-2002
ENVIROCYCLE	Active	Mar-09-2004
FEDERAL WAY DISPOSAL	Active	Mar-20-2000
GRAHAM ROAD RECYCLING AND DISPOSAL	Active	Jun-20-2016
GRAHAM ROAD RECYCLING AND DISPOSAL FACILITY	Active	Apr-29-2002
OLMPIC VIEW TRANSFER STATION	Active	Nov-14-2003
RECYCLING NORTHWEST	Active	Feb-28-2008
SPOKANE MATERIAL AND RECYCLING TECHNOLOGY CENTER	Active	Oct-05-2011
SPOKANE RECYCLING PRODUCTS	Active	Oct-05-2012
WASHINGTON WASTE SYSTEMS	Active	Apr-29-2002
WASTE MANAGEMENT	Active	Aug-12-1997
WASTE MANAGEMENT - MARYSVILLE	Active	Feb-07-2012
WASTE MANAGEMENT - NORTH SOUND	Active	Feb-06-2012

[View Additional Locations](#)

The Business Lookup information is updated nightly. Search date and time: 10/9/2024 8:32:37 AM

**Contact us**

How are we doing?

**Take our survey!**

Don't see what you expected?

**Check if your browser is supported**





# CERTIFICATE OF LIABILITY INSURANCE

1/1/2025

DATE (MM/DD/YYYY)

12/13/2023

THIS CERTIFICATE IS ISSUED AS A MATTER OF INFORMATION ONLY AND CONFERS NO RIGHTS UPON THE CERTIFICATE HOLDER. THIS CERTIFICATE DOES NOT AFFIRMATIVELY OR NEGATIVELY AMEND, EXTEND OR ALTER THE COVERAGE AFFORDED BY THE POLICIES BELOW. THIS CERTIFICATE OF INSURANCE DOES NOT CONSTITUTE A CONTRACT BETWEEN THE ISSUING INSURER(S), AUTHORIZED REPRESENTATIVE OR PRODUCER, AND THE CERTIFICATE HOLDER.

**IMPORTANT:** If the certificate holder is an ADDITIONAL INSURED, the policy(ies) must have ADDITIONAL INSURED provisions or be endorsed. If SUBROGATION IS WAIVED, subject to the terms and conditions of the policy, certain policies may require an endorsement. A statement on this certificate does not confer rights to the certificate holder in lieu of such endorsement(s).

PRODUCER LOCKTON COMPANIES 3657 BRIARPARK DRIVE, SUITE 700 HOUSTON TX 77042 866-260-3538	CONTACT NAME:		
	PHONE (A/C. No. Ext):	FAX (A/C. No.):	
INSURED 1300299 WASTE MANAGEMENT HOLDINGS, INC. & ALL AFFILIATED, RELATED & SUBSIDIARY COMPANIES INCLUDING: WM SMART CENTER 2902 S GEIGER BOULEVARD SPOKANE WA 99224	INSURER(S) AFFORDING COVERAGE		NAIC #
	INSURER A : Indemnity Insurance Co of North America		43575
	INSURER B : ACE American Insurance Company		22667
	INSURER C : ACE Fire Underwriters Insurance Company		20702
	INSURER D : ACE Property and Casualty Insurance Company		20699
	INSURER E :		
INSURER F :			

**COVERAGES**      **CERTIFICATE NUMBER:** 12145218      **REVISION NUMBER:** XXXXXXXX

THIS IS TO CERTIFY THAT THE POLICIES OF INSURANCE LISTED BELOW HAVE BEEN ISSUED TO THE INSURED NAMED ABOVE FOR THE POLICY PERIOD INDICATED. NOTWITHSTANDING ANY REQUIREMENT, TERM OR CONDITION OF ANY CONTRACT OR OTHER DOCUMENT WITH RESPECT TO WHICH THIS CERTIFICATE MAY BE ISSUED OR MAY PERTAIN, THE INSURANCE AFFORDED BY THE POLICIES DESCRIBED HEREIN IS SUBJECT TO ALL THE TERMS, EXCLUSIONS AND CONDITIONS OF SUCH POLICIES. LIMITS SHOWN MAY HAVE BEEN REDUCED BY PAID CLAIMS.

INSR LTR	TYPE OF INSURANCE	ADDL INSD	SUBR WVD	POLICY NUMBER	POLICY EFF (MM/DD/YYYY)	POLICY EXP (MM/DD/YYYY)	LIMITS
B	<input checked="" type="checkbox"/> COMMERCIAL GENERAL LIABILITY <input type="checkbox"/> CLAIMS-MADE <input checked="" type="checkbox"/> OCCUR <input checked="" type="checkbox"/> XCU INCLUDED <input checked="" type="checkbox"/> ISO FORM CG00010413 GEN'L AGGREGATE LIMIT APPLIES PER: <input type="checkbox"/> POLICY <input checked="" type="checkbox"/> PRO-JECT <input checked="" type="checkbox"/> LOC <input type="checkbox"/> OTHER:	Y	Y	HDO G48902339	1/1/2024	1/1/2025	EACH OCCURRENCE \$ 5,000,000 DAMAGE TO RENTED PREMISES (Ea occurrence) \$ 5,000,000 MED EXP (Any one person) \$ XXXXXXXX PERSONAL & ADV INJURY \$ 5,000,000 GENERAL AGGREGATE \$ 6,000,000 PRODUCTS - COMP/OP AGG \$ 6,000,000 \$
B	<input checked="" type="checkbox"/> AUTOMOBILE LIABILITY <input checked="" type="checkbox"/> ANY AUTO <input checked="" type="checkbox"/> OWNED AUTOS ONLY <input type="checkbox"/> SCHEDULED AUTOS <input checked="" type="checkbox"/> HIRED AUTOS ONLY <input checked="" type="checkbox"/> NON-OWNED AUTOS ONLY <input checked="" type="checkbox"/> MCS-90	Y	Y	MMT H10822294	1/1/2024	1/1/2025	COMBINED SINGLE LIMIT (Ea accident) \$ 1,000,000 BODILY INJURY (Per person) \$ XXXXXXXX BODILY INJURY (Per accident) \$ XXXXXXXX PROPERTY DAMAGE (Per accident) \$ XXXXXXXX \$ XXXXXXXX
D	<input checked="" type="checkbox"/> UMBRELLA LIAB <input checked="" type="checkbox"/> OCCUR <input type="checkbox"/> EXCESS LIAB <input type="checkbox"/> CLAIMS-MADE DED      RETENTION \$	Y	Y	XEU G27929242 009	1/1/2024	1/1/2025	EACH OCCURRENCE \$ 15,000,000 AGGREGATE \$ 15,000,000 \$ XXXXXXXX
A B C	<input checked="" type="checkbox"/> WORKERS COMPENSATION AND EMPLOYERS' LIABILITY ANY PROPRIETOR/PARTNER/EXECUTIVE OFFICER/MEMBER EXCLUDED? (Mandatory in NH) If yes, describe under DESCRIPTION OF OPERATIONS below	Y/N N	Y N/A	WLR C55517010 (AOS) WLR C55516881 (AZ, CA & MA) SCF C55517083 (WI)	1/1/2024 1/1/2024 1/1/2024	1/1/2025 1/1/2025 1/1/2025	<input checked="" type="checkbox"/> PER STATUTE <input type="checkbox"/> OTH-ER E.L. EACH ACCIDENT \$ 3,000,000 E.L. DISEASE - EA EMPLOYEE \$ 3,000,000 E.L. DISEASE - POLICY LIMIT \$ 3,000,000
B	EXCESS AUTO LIABILITY	Y	Y	XSA H10822233	1/1/2024	1/1/2025	COMBINED SINGLE LIMIT \$9,000,000 (EACH ACCIDENT)

DESCRIPTION OF OPERATIONS / LOCATIONS / VEHICLES (ACORD 101, Additional Remarks Schedule, may be attached if more space is required)  
 BLANKET WAIVER OF SUBROGATION IS GRANTED IN FAVOR OF CERTIFICATE HOLDER ON ALL POLICIES WHERE AND TO THE EXTENT REQUIRED BY WRITTEN CONTRACT WHERE PERMISSIBLE BY LAW. CERTIFICATE HOLDER IS NAMED AS AN ADDITIONAL INSURED ON ALL POLICIES (EXCEPT FOR WORKERS' COMP/EMPLOYER'S LIABILITY) WHERE AND TO THE EXTENT REQUIRED BY WRITTEN CONTRACT.

**CERTIFICATE HOLDER****CANCELLATION**

<b>12145218</b> CITY OF SPOKANE 808 W. SPOKANE FALLS BOULEVARD SPOKANE WA 99201-3342	SHOULD ANY OF THE ABOVE DESCRIBED POLICIES BE CANCELLED BEFORE THE EXPIRATION DATE THEREOF, NOTICE WILL BE DELIVERED IN ACCORDANCE WITH THE POLICY PROVISIONS.  AUTHORIZED REPRESENTATIVE 
---	---

© 1988-2015 ACORD CORPORATION. All rights reserved.

**Agenda Sheet for City Council:****Committee:** PIES **Date:** 08/19/2024**Committee Agenda type:** Consent**Date Rec'd**

8/7/2024

**Clerk's File #**

OPR 2024-0938

**Cross Ref #****Project #**

2018102

**Council Meeting Date:** 11/04/2024**Submitting Dept**

ENGINEERING SERVICES

**Bid #****Contact Name/Phone**

DAN BULLER 509-625-6391

**Requisition #**

2025 BUDGET

**Contact E-Mail**

DBULLER@SPOKANECITY.ORG

**Agenda Item Type**

Engineer Construction Contract

**Council Sponsor(s)**

BWILKERSON JBINGLE KKLITZKE

**Agenda Item Name**

0370 - LOW BID AWARD - PLAINS BOOSTER STATION REPLACEMENT

**Agenda Wording**

Low Bid of Apollo Inc. (Kennewick, WA) for Plains Booster Station Replacement - \$4,698,520.10 plus tax. An administrative reserve of \$469,852.01 plus tax, which is 10% of the contract, will be set aside. (West Hills Neighborhood Council)

**Summary (Background)**

On October 21, 2024, bids were opened for the above project. The low bid from Apollo Inc., in the amount of \$4,698,520.10, which is \$356,638.85 or 7% below the Engineer's Estimate of \$5,055,158.95. Five other bids were received as follows: DW Excavating Inc - \$4,760,580.00, Halme Construction Inc - \$4,770,213.00, Clearwater Construction & Management LLC - \$5,174,158.15, Big Sky ID Corp - \$5,396,990.80, S&L Underground - \$5,533,298.00.

Lease? NO

Grant related? NO

Public Works? YES

**Fiscal Impact**

Approved in Current Year Budget? YES

Total Cost

\$ 4,698,520.10

Current Year Cost

\$

Subsequent Year(s) Cost

\$

**Narrative****Amount****Budget Account**

Expense

\$ 6,300,000

# 4250-98818-94340-56501-15799

Expense

\$ 1,000,000

# 4250-98863-94340-56501-15799

Select

\$

#

Select

\$

#

\$

#

\$

#





**Continuation of Wording, Summary, Approvals, and Distribution**

**Agenda Wording**

**Summary (Background)**

**Approvals**

<b><u>Dept Head</u></b>	BULLER, DAN
<b><u>Division Director</u></b>	MILLER, KATHERINE E
<b><u>Accounting Manager</u></b>	ORLOB, KIMBERLY
<b><u>Legal</u></b>	PICCOLO, MIKE
<b><u>For the Mayor</u></b>	JONES, GARRETT

**Additional Approvals**

<b><u>PURCHASING</u></b>	WAHL, CONNIE

**Distribution List**

Amy.Jenne@apollo-gc.com	jrhall@spokanecity.org
eraea@spokanecity.org	publicworksaccounting@spokanecity.org
tax&licenses@spokanecity.org	pyoung@spokanecity.org
dbuller@spokanecity.org	jradams@spokanecity.org

## Committee Agenda Sheet

### Public Infrastructure, Environment & Sustainability Committee

<b>Committee Date</b>	8-19-24
<b>Submitting Department</b>	Engineering Services
<b>Contact Name</b>	Dan Buller
<b>Contact Email &amp; Phone</b>	<a href="mailto:dbuller@spokanecity.org">dbuller@spokanecity.org</a> , 625-6391
<b>Council Sponsor(s)</b>	Wilkerson, Bingle, Klitzke
<b>Select Agenda Item Type</b>	<input checked="" type="checkbox"/> Consent <input type="checkbox"/> Discussion    Time Requested:
<b>Agenda Item Name</b>	Spotted Rd Booster Station Replacement
<b>Proposed Council Action</b>	<input checked="" type="checkbox"/> Approval to proceed to Legislative Agenda <input type="checkbox"/> Information Only
<b>Summary (Background)</b>  *use the Fiscal Impact box below for relevant financial information	<ul style="list-style-type: none"> <li>This project installs a second booster station next to the existing 40 year old booster station. See two attached exhibits.</li> <li>A second booster station is needed in part because of growth within city limits on the west plains and in part because of potential water sales to Airway Heights.</li> <li>This project is funded by a low interest state loan, to be repaid with water rate revenue, and a \$1M ARP grant.</li> <li>Construction is planned for 2025 but the construction contract must be signed by the end of 2024 per the terms of the grant.</li> <li>Except for the tie-in of this booster station to the water main on Westbow Blvd., traffic impacts will be minimal since this project is outside the roadway.</li> </ul>
<b>Fiscal Impact</b> <b>Approved in current year budget?</b> <input checked="" type="checkbox"/> Yes <input type="checkbox"/> No <input type="checkbox"/> N/A Total Cost: <u>\$5.1M</u> Current year cost: \$100,000 Subsequent year(s) cost: \$5M (2025)	
<b>Narrative:</b> Please provide financial due diligence review, as applicable, such as number and type of positions, grant match requirements, summary type details (personnel, maintenance and supplies, capital, revenue), impact on rates, fees, or future shared revenue	
<b>Funding Source</b> <input checked="" type="checkbox"/> One-time <input type="checkbox"/> Recurring <input type="checkbox"/> N/A Specify funding source: Select Funding Source* Is this funding source sustainable for future years, months, etc? <a href="#">Click or tap here to enter text.</a>	
<b>Expense Occurrence</b> <input checked="" type="checkbox"/> One-time <input type="checkbox"/> Recurring <input type="checkbox"/> N/A  Other budget impacts: (revenue generating, match requirements, etc.)	
<b>Operations Impacts (If N/A, please give a brief description as to why)</b> <ul style="list-style-type: none"> <li>What impacts would the proposal have on historically excluded communities? Public works services and projects are designed to serve all citizens and businesses. We strive to offer a consistent level of service to all, to distribute public investment throughout the community and to respond to gaps in services identified in various City plans.</li> </ul>	







**City of Spokane**  
**PUBLIC WORKS CONTRACT**  
Title: **PLAINS BOOSTER STATION**

This Contract is made and entered into by and between the **CITY OF SPOKANE** as ("City"), a Washington municipal corporation, and **APOLLO, INC.**, whose address is 1133 West Columbia Drive, Kennewick, Washington 99336 as ("Contractor"), individually hereafter referenced as a "Party", and together as the "Parties".

The parties agree as follows:

1. **PERFORMANCE.** The Contractor will do all work, furnish all labor, materials, tools, construction equipment, transportation, supplies, supervision, organization and other items of work and costs necessary for the proper execution and completion of the work described in the Special Provisions entitled **PLAINS BOOSTER STATION.**
2. **CONTRACT DOCUMENTS.** The contract documents are this Contract, the Contractor's completed bid proposal form, the Washington State Department of Transportation's Standard Specifications for Road, Bridge and Municipal Construction 2024, City of Spokane Special Provisions, contract provisions, contract plans, standard plans, addenda, various certifications and affidavits, supplemental agreements, change orders and subsurface boring logs (if any). These contract documents are on file in the Engineering Services Department and are incorporated into this Contract by reference as if they were set forth at length. In the event of a conflict, or to resolve an ambiguity or dispute, the order of precedence defined in the City of Spokane Special Provisions section 1-04.2 City Engineering Services File No. 2018102 shall apply.
3. **TIME OF PERFORMANCE.** The time of performance of the Contract shall be in accordance with the contract documents.
4. **LIQUIDATED DAMAGES.** Liquidated damages shall be in accordance with the contract documents.
5. **TERMINATION.** Either party may terminate this Contract in accordance with the contract documents.
6. **COMPENSATION.** This is a unit price contract, and upon full and complete performance by the Contractor, the City will pay only the amount set forth in Schedule A-1 for the actual quantities furnished for each bid item at a total cost not to exceed \$4,698,520.10, which are taxed as noted in Section 7.

7. TAXES. Bid items in Schedule A-2 shall not include sales tax.
8. PAYMENT. The Contractor will send its applications for payment to the Engineering Services Department, 998 E North Foothills Drive Spokane, WA 99207-2735. All invoices should include the City Clerk's File No. "OPR XXXX-XXXX" and an approved L & I Intent to Pay Prevailing Wage number. The final invoice should include an approved Affidavit of Wages Paid number. Payment will not be made without this documentation included on the invoice. **Payment will be made via direct deposit/ACH** within thirty (30) days after receipt of the Company's application except as provided by state law. Five percent (5%) of the Contract price may be retained by the City, in accord with RCW 60.28 for a minimum of forty five (45) days after final acceptance, as a trust fund for the protection and payment of: the claims of any person arising under the Contract; and the State with respect to taxes imposed pursuant to Titles 50, 51 and 82 RCW which may be due from the Contractor.
9. INDEMNIFICATION. The Contractor shall defend, indemnify, and hold the City and its officers and employees harmless from all claims, demands, or suits at law or equity asserted by third parties for bodily injury (including death) and/or property damage which arise from the Contractor's negligence or willful misconduct under this Agreement, including attorneys' fees and litigation costs; provided that nothing herein shall require a Contractor to indemnify the City against and hold harmless the City from claims, demands or suits based solely upon the negligence of the City, its agents, officers, and employees. If a claim or suit is caused by or results from the concurrent negligence of the Contractor's agents or employees and the City, its agents, officers and employees, this indemnity provision shall be valid and enforceable to the extent of the negligence of the Contractor, its agents or employees. The Contractor specifically assumes liability and agrees to defend, indemnify, and hold the City harmless for actions brought by the Contractor's own employees against the City and, solely for the purpose of this indemnification and defense, the Contractor specifically waives any immunity under the Washington State industrial insurance law, or Title 51 RCW. The Contractor recognizes that this waiver was specifically entered into pursuant to the provisions of RCW 4.24.115 and was the subject of mutual negotiation. The indemnity and agreement to defend and hold the City harmless provided for in this section shall survive any termination or expiration of this agreement.
10. BONDS. The Contractor may not commence work until it obtains all insurance, permits and bonds required by the contract documents and applicable law. This includes the execution of a performance bond and a payment bond on the forms attached, each equal to one hundred percent (100%) of the contract price, and written by a corporate surety company licensed to do business in Washington State.
11. INSURANCE. The Contractor represents that it and its employees, agents and subcontractors, in connection with the Contract, are protected against the risk of loss by the insurance coverages required in the contract documents attached hereto including attached Certificates of Insurance (COI) and any other insurance documents attached. The policies shall be issued by companies that meet with the approval of the City Risk Manager. The policies shall not be canceled without at least minimum required written notice to the City as Additional Insured.
12. CONTRACTOR'S WARRANTY. The Contractor's warranty for all work, labor and materials shall be in accordance with the contract documents.
13. WAGES. Contractor will comply with the Davis Bacon Act (40 USC 3141-3144, and 3146-3148) as supplemented by Department of Labor regulations (29 CFR Part 5, "Labor Standards Provisions Applicable to Contracts Covering Federally Financed and Assisted Construction").

Minimum wages paid by the Contractor will be those determined by the Secretary of Labor under the Davis Bacon Act, 40 USC 276(a). In the event that a state minimum wage rate exceeds a Department of Labor rate, the conflict will be resolved by applying the higher rate. The Contractor and all subcontractors will submit a "Statement of Intent to Pay Prevailing Wages" certified by the industrial statistician of the State Department of Labor and Industries, prior to any payments. The "Statement of Intent to Pay Prevailing Wages" shall include: (1) the Contractor's registration number; and (2) the prevailing rate of wage for each classification of workers entitled to prevailing wages under RCW 39.12.020 and the number of workers in each classification. Each voucher claim submitted by the Contractor for payment on a project estimate shall state that the prevailing wages have been paid in accordance with the "Statement(s) of Intent to Pay Prevailing Wages" on file with the City.

Under 40 USC 3702 of the Act, contractor is required to compute the wages of every mechanic and laborer on the basis of a standard work week of 40 hours. Work in excess of the standard work week is permissible provided that the worker is compensated at a rate of not less than one and a half times the basic rate of pay for all hours worked in excess of 40 hours in the work week. No laborer or mechanic may be required to work in surroundings or under working conditions which are unsanitary, hazardous or dangerous.

14. STATEMENT OF INTENT TO PAY PREVAILING WAGES TO BE POSTED. The Contractor and each subcontractor required to pay the prevailing rate of wages shall post in a location readily visible at the job site: (1) a copy of a "Statement of Intent to Pay Prevailing Wages" approved by the industrial statistician of the State Department of Labor and Industries; and (2) the address and telephone number of the industrial statistician of the Department of Labor and Industries where a complaint or inquiry concerning prevailing wages may be made.

15. PUBLIC WORKS REQUIREMENTS. The Contractor and each subcontractor are required to fulfill the Department of Labor and Industries Public Works and Prevailing Wage Training Requirement under RCW 39.04.350. The contractor must verify responsibility criteria for each first tier subcontractor, and a subcontractor of any tier that hires other subcontractors must verify the responsibility criteria listed in RCW 39.04.350(1) for each of its subcontractors. Verification shall include that each subcontractor, at the time of subcontract execution, meets the responsibility criteria. This verification requirement, as well as responsibility criteria, must be included in every public works contract and subcontract of every tier.

16. SUBCONTRACTOR RESPONSIBILITY.

A. The Contractor shall include the language of this section in each of its first tier subcontracts, and shall require each of its subcontractors to include the same language of this section in each of their subcontracts, adjusting only as necessary the terms used for the contracting parties. Upon request of the City, the Contractor shall promptly provide documentation to the City demonstrating that the subcontractor meets the subcontractor responsibility criteria below. The requirements of this section apply to all subcontractors regardless of tier.

B. At the time of subcontract execution, the Contractor shall verify that each of its first tier subcontractors meets the following bidder responsibility criteria:

1. Have a current certificate of registration in compliance with chapter 18.27 RCW, which must have been in effect at the time of subcontract bid submittal;
2. Have a current Washington Unified Business Identifier (UBI) number;

3. If applicable, have:
  - a. Industrial Insurance (workers' compensation) coverage for the subcontractor's employees working in Washington, as required in Title 51 RCW;
  - b. A Washington Employment Security Department number, as required in Title 50 RCW;
  - c. A Washington Department of Revenue state excise tax registration number, as required in Title 82 RCW;
  - d. An electrical contractor license, if required by Chapter 19.28 RCW;
  - e. An elevator contractor license, if required by Chapter 70.87 RCW.
4. Not be disqualified from bidding on any public works contract under RCW 39.06.010 or 39.12.065 (3).

C. On Public Works construction projects, as defined in RCW 39.04.010, with an estimated cost of six hundred thousand dollars (\$600,000) or more, at least fifteen (15) percent of the labor hours on each project shall be performed by apprentices enrolled in a State-approved apprenticeship program; and for each contract in the project fifteen (15) percent of the labor hours for each craft that has an available state-approved apprenticeship program for Spokane County and utilizes more than one hundred sixty (160) hours in each contract; shall be performed by apprentices enrolled in a state-approved apprenticeship program.

1. **Subcontracting Requirements.** The utilization percentages for apprenticeship labor for Public Works construction contracts shall also apply to all subcontracts of one hundred thousand dollars (\$100,000) or more within those contracts, and at least fifteen percent (15%) of the labor hours for each such subcontract shall be performed by apprentices in a state-approved apprenticeship program. For each craft that has an available apprenticeship program for Spokane county and performs more than one hundred sixty (160) hours on each project, fifteen (15) percent of the labor hours shall be performed by apprentices enrolled in a State-approved apprenticeship program.
2. Each subcontractor which this chapter applies to is required to execute a form, provided by the city, acknowledging that the requirements of Article X 07.06 SMC are applicable to the labor hours for the project.

17. **NONDISCRIMINATION.** No individual shall be excluded from participation in, denied the benefit of, subjected to discrimination under, or denied employment in the administration of or in connection with this Contract because of age, sex, race, color, religion, creed, marital status, familial status, sexual orientation including gender expression or gender identity, national origin, honorably discharged veteran or military status, the presence of any sensory, mental or physical disability, or use of a service animal by a person with disabilities. The Contractor agrees to comply with, and to require that all subcontractors comply with, Section 504 of the Rehabilitation Act of 1973 and the Americans with Disabilities Act, as applicable to the Contractor.

18. **EXECUTIVE ORDER 11246.**

A. The Contractor will not discriminate against any employee or applicant for employment because of race, color, religion, sex or national origin. The Contractor will take affirmative



action to insure that applicants are employed, and that employees are treated during employment, without regard to their race, color, religion, sex or national origin. Such action shall include but not be limited to the following: employment upgrading, demotion or transfer; recruitment or recruitment advertising; layoff or termination; rates of pay or other forms of compensation; and selection for training, including apprenticeship. The Contractor agrees to post in conspicuous places, available to employees and applicants for employment, notices to be provided by the contracting officer setting forth the provisions of this nondiscrimination clause.

- B. The Contractor will, in all solicitations or advertisements for employees placed by or on behalf of the Contractor, state that all qualified applicants will receive consideration for employment without regard to race, color, religion, sex or national origin.
- C. The Contractor will send each labor union, or representative of workers with which it has a collective bargaining contract or other contract or understanding, a notice, to be provided by the agency contracting officer, advising the labor union or workers' representative of the Contractor's commitments under Section 202 of Executive Order No. 11246 of September 24, 1965, and shall post copies of the notice in conspicuous places available to employees and applicants for employment.
- D. The Contractor will comply with all provisions of Executive Order No. 11246 of September 24, 1965, and of the rules, regulations, and relevant orders of the Secretary of Labor.
- E. The Contractor will furnish all information and reports required by Executive Order No. 11246 of September 24, 1965, and by the rules, regulations and orders of the Secretary of Labor, or pursuant thereto, and will permit access to its books, records, and accounts by the contracting agency and the Secretary of Labor for purposes of investigation to ascertain compliance with such rules, regulations and orders.
- F. In the event of the Contractor's noncompliance with the nondiscrimination clauses of this Contract or with any of such rules, regulations or orders, this Contract may be canceled, terminated or suspended in whole or in part, and the Contractor may be declared ineligible for further government contracts in accordance with procedures authorized in Executive Order No. 11246 of September 24, 1965, and such other sanctions may be imposed and remedies invoked as provided in Executive Order No. 11246 of September 24, 1965, or by rule, regulation, or order of the Secretary of Labor, or as otherwise provided by law.
- G. The Contractor will include the provisions of paragraphs A through G in every subcontract or purchase order unless exempted by rules, regulations or orders of the Secretary of Labor issued pursuant to Section 204 of Executive Order No. 11246 of September 24, 1965, so that such provisions will be binding upon each subcontractor or vendor. The Contractor will take such action with respect to any subcontract or purchase order as may be directed by the Secretary of Labor as a means of enforcing such provisions including sanctions for noncompliance: PROVIDED, HOWEVER, that in the event the Contractor becomes involved in, or is threatened with, litigation with a subcontractor or vendor as the result of such direction, the Contractor may request the United States to enter into such litigation to protect the interests of the United States.

19. DEBARMENT AND SUSPENSION. The Contractor has provided its certification that it is in compliance with and shall not contract with individuals or organizations which are debarred, suspended, or otherwise excluded from or ineligible from participation in Federal Assistance Programs under Executive Order 12549 and "Debarment and Suspension", codified at 29 CFR part 98.

20. ASSIGNMENTS. The Contractor may not assign, transfer or sublet any part of the work under this Contract, or assign any monies due, without the written approval of the City, except as may be required by law. In the event of assignment of accounts or monies due under this Contract,

the Contractor specifically agrees to give immediate written notice to the City Administrator, no later than five (5) business days after the assignment.

21. ANTI-KICKBACK. No officer or employee of the City of Spokane, having the power or duty to perform an official act or action related to this Contract shall have or acquire any interest in the Contract, or have solicited, accepted or granted a present or future gift, favor, service or other thing of value from or to any person involved in the Contract. Contractor will comply with the Copeland "Anti-Kickback" Act (40 USC 3145), as supplemented by Department of Labor Regulations (29 CFR Part 3, "Contractors and Subcontractors on Public Building or Public Work Financed in Whole or in Part by Loans or Grants from the United States").

22. COMPLIANCE WITH LAWS. Each party shall comply with all applicable federal, state, and local laws and regulations that are incorporated herein by reference.

23. DISPUTES. This Contract shall be performed under the laws of the State of Washington. Any litigation to enforce this Contract or any of its provisions shall be brought in Spokane County, Washington.

24. SEVERABILITY. In the event any provision of this Contract should become invalid, the rest of the Contract shall remain in full force and effect.

25. AUDIT / RECORDS. The Contractor and its subcontractors shall maintain for a minimum of three (3) years following final payment all records related to its performance of the Contract. The Contractor and its subcontractors shall provide access to authorized City representatives, at reasonable times and in a reasonable manner to inspect and copy any such record. In the event of conflict between this provision and related auditing provisions required under federal law applicable to the Contract, the federal law shall prevail.

26. BUSINESS REGISTRATION REQUIREMENT. Section 8.01.070 of the Spokane Municipal Code states that no person may engage in business with the City without first having obtained a valid annual business registration. The Contractor shall be responsible for contacting the State of Washington Business License Services at [www.dor.wa.gov](http://www.dor.wa.gov) or 360-705-6741 to obtain a business registration. If the Contractor does not believe it is required to obtain a business registration, it may contact the City's Taxes and Licenses Division at (509) 625-6070 to request an exemption status determination.

27. CONSTRUAL. The Contractor acknowledges receipt of a copy of the contract documents and agrees to comply with them. The silence or omission in the contract documents concerning any detail required for the proper execution and completion of the work means that only the best general practice is to prevail and that only material and workmanship of the best quality are to be used. This Contract shall be construed neither in favor of nor against either party.

28. MODIFICATIONS. The City may modify this Contract and order changes in the work whenever necessary or advisable. The Contractor will accept modifications when ordered in writing by the Director of Engineering Services, and the Contract time and compensation will be adjusted accordingly.

29. INTEGRATION. This Contract, including any and all exhibits and schedules referred to herein or therein set forth the entire Agreement and understanding between the parties pertaining to the subject matter and merges all prior agreements, negotiations and discussions between them on the same subject matter.

30. OFF SITE PREFABRICATED ITEMS. In accordance with RCW 39.04.370, the Contractor shall submit certain information about off-site, prefabricated, nonstandard, project specific items produced under the terms of the Contract and produced outside Washington as a part of the "Affidavit of Wages Paid" form filed with the State Department of Labor and Industries.

31. FORCE MAJEURE. Neither party shall be liable to the other for any failure or delay in performing its obligations hereunder, or for any loss or damage resulting therefrom, due to: (1) acts of God or public enemy, acts of government, riots, terrorism, fires, floods, strikes, lock outs, epidemics, act or failure to act by the other party, or unusually severe weather affecting City, Contractor or its subcontractors, or (2) causes beyond their reasonable control and which are not foreseeable (each a "Force Majeure Event"). In the event of any such Force Majeure Event, the date of delivery or performance shall be extended for a period equal to the time lost by reason of the delay.

32. CLEAN AIR ACT. Contractor must comply with all applicable standards, orders or regulations issued pursuant to the Clean Air Act (42 USC 7401-7671q) and the Federal Water Pollution Control Act as amended (33 USC 1251-1387). Violations will be reported.

33. USE OF PROJECT MANAGEMENT SOFTWARE. The Contractor shall transmit all submittal documentation for proposed project materials by uploading it to the City's web based construction management software. A City representative will be available to assist in learning this process.

**APOLLO, INC.**

**CITY OF SPOKANE**

By \_\_\_\_\_  
Signature                      Date

By \_\_\_\_\_  
Signature                      Date

\_\_\_\_\_  
Type or Print Name

\_\_\_\_\_  
Type or Print Name

\_\_\_\_\_  
Title

\_\_\_\_\_  
Title

Attest:

Approved as to form:

\_\_\_\_\_  
City Clerk

\_\_\_\_\_  
Assistant City Attorney

**Attachments that are part of this Contract:**

- Payment Bond
  - Performance Bond
  - Certification Regarding Debarment
  - Schedule A-1 and Schedule A-2
- 24-219

**PAYMENT BOND**

We, **APOLLO, INC.**, as principal, and \_\_\_\_\_, as surety, are held and firmly bound to the City of Spokane, Washington, in the sum of **FOUR MILLION SIX HUNDRED NINETY-EIGHT THOUSAND FIVE HUNDRED TWENTY AND 10/100 DOLLARS (\$4,698,520.10)** the payment of which, we bind ourselves and our legal representatives and successors, jointly and severally by this document.

The principal has entered into a contract with the City of Spokane, Washington, to do all work and furnish all materials for the **PLAINS BOOSTER STATION**. If the principal shall:

- A. pay all laborers, mechanics, subcontractors, material suppliers and all person(s) who shall supply such person or subcontractors; and pay all taxes and contributions, increases and penalties as authorized by law; and
- B. comply with all applicable federal, state and local laws and regulations;

then this obligation shall be null and void; otherwise it shall remain in full force and effect.

The Surety for value received agrees that no change, extension of time, alteration or addition to the terms of the Contract, the specifications accompanying the Contract, or to the work to be performed under the Contract shall in any way affect its obligation on this bond, except as provided herein, and waives notice of any change, extension of time, alteration or addition to the terms of the Contract or the work performed. The Surety agrees that modifications and changes to the terms and conditions of the Contract that increase the total amount to be paid the Principal shall automatically increase the obligation of the Surety on this bond and notice to Surety is not required for such increased obligation. Any judgment obtained against the City, which relates to or is covered by the contract or this bond, shall be conclusive against the principal and the surety, as to the amount of damages, and their liability, if reasonable notice of the suit has been given.

SIGNED AND SEALED on \_\_\_\_\_.

**APOLLO, INC.,**

AS PRINCIPAL

By: \_\_\_\_\_

Title: \_\_\_\_\_

\_\_\_\_\_,  
AS SURETY

By: \_\_\_\_\_

Its Attorney in Fact

A valid POWER OF ATTORNEY  
for the Surety's agent must  
accompany this bond.

STATE OF WASHINGTON        )  
  ) ss.  
County of \_\_\_\_\_)

I certify that I know or have satisfactory evidence that \_\_\_\_\_  
\_\_\_\_\_ signed this document; on oath stated that he/she was  
authorized to sign the document and acknowledged it as the agent or representative of the  
named surety company which is authorized to do business in the State of Washington, for  
the uses and purposes therein mentioned.

DATED: \_\_\_\_\_

\_\_\_\_\_

Signature of Notary Public

My appointment expires \_\_\_\_\_

**PERFORMANCE BOND**

We, **APOLLO, INC.**, as principal, and \_\_\_\_\_, as Surety, are held and firmly bound to the City of Spokane, Washington, in the sum of **FOUR MILLION SIX HUNDRED NINETY-EIGHT THOUSAND FIVE HUNDRED TWENTY AND 10/100 DOLLARS (\$4,698,520.10)** for the payment of which, we bind ourselves and our legal representatives and successors, jointly and severally by this document.

The principal has entered into a Contract with the City of Spokane, Washington, to do all the work and furnish all materials for the **PLAINS BOOSTER STATION**. If the principal shall:

- A. promptly and faithfully perform the Contract, and any contractual guaranty and indemnify and hold harmless the City from all loss, damage or claim which may result from any act or omission of the principal, its agents, employees, or subcontractors; and
- B. comply with all applicable federal, state and local laws and regulations;

then this obligation shall be null and void; otherwise it shall remain in full force and effect.

The Surety for value received agrees that no change, extension of time, alteration or addition to the terms of the Contract, the specifications accompanying the Contract, or to the work to be performed under the Contract shall in any way affect its obligation on this bond, except as provided herein, and waives notice of any change, extension of time, alteration or addition to the terms of the Contract or the work performed. The Surety agrees that modifications and changes to the terms and conditions of the Contract that increase the total amount to be paid the Principal shall automatically increase the obligation of the Surety on this bond and notice to Surety is not required for such increased obligation. Any judgment obtained against the City, which relates to or is covered by the Contract or this bond, shall be conclusive against the principal and the Surety, not only as to the amount of damages, but also as to their liability, if reasonable notice of the suit has been given.

SIGNED AND SEALED on \_\_\_\_\_

**APOLLO, INC.,**

AS PRINCIPAL

By: \_\_\_\_\_  
Title: \_\_\_\_\_

\_\_\_\_\_,  
AS SURETY

By: \_\_\_\_\_  
Its Attorney in Fact

A valid POWER OF ATTORNEY  
for the Surety's agent must  
accompany this bond.

STATE OF WASHINGTON            )  
  ) ss.  
County of \_\_\_\_\_            )

I certify that I know or have satisfactory evidence that \_\_\_\_\_  
\_\_\_\_\_ signed this document; on oath stated that  
he/she was authorized to sign the document and acknowledged it as the agent or representative of  
the named Surety Company which is authorized to do business in the State of Washington, for the  
uses and purposes mentioned in this document.

DATED on \_\_\_\_\_.

\_\_\_\_\_  
Signature of Notary

My appointment expires \_\_\_\_\_

**CERTIFICATION REGARDING DEBARMENT, SUSPENSION,  
INELIGIBILITY AND VOLUNTARY EXCLUSION**

1. The undersigned (i.e., signatory for the Subrecipient / Contractor / Consultant) certifies, to the best of its knowledge and belief, that it and its principals:
  - a. Are not presently debarred, suspended, proposed for debarment, declared ineligible, or voluntarily excluded from covered transactions by any federal department or agency;
  - b. Have not within a three-year period preceding this contract been convicted or had a civil judgment rendered against them for commission of fraud or a criminal offense in connection with obtaining, attempting to obtain, or performing a public (federal, state, or local) transaction or contract under a public transaction; violation of federal or state antitrust statutes or commission of embezzlement, theft, forgery, bribery, falsification or destruction of records, making false statements, tax evasion, receiving stolen property, making false claims, or obstruction of justice;
  - c. Are not presently indicted or otherwise criminally or civilly charged by a government entity (federal, state, or local) with commission of any of the offenses enumerated in paragraph (1)(b) of this certification; and,
  - d. Have not within a three-year period preceding this contract had one or more public transactions (federal, state, or local) terminated for cause or default.
  
2. The undersigned agrees by signing this contract that it shall not knowingly enter into any lower tier covered transaction with a person who is debarred, suspended, declared ineligible, or voluntarily excluded from participation in this covered transaction.
  
3. The undersigned further agrees by signing this contract that it will include the following clause, without modification, in all lower tier covered transactions and in all solicitations for lower tier covered transactions:
 

Certification Regarding Debarment, Suspension, Ineligibility and Voluntary Exclusion – Lower Tier Covered Transactions

  1. The lower tier contractor certifies, by signing this contract that neither it nor its principals is presently debarred, suspended, proposed for debarment, declared ineligible, or voluntarily excluded from participation in this transaction by any federal department or agency.
  2. Where the lower tier contractor is unable to certify to any of the statements in this contract, such contractor shall attach an explanation to this contract.
  
4. I understand that a false statement of this certification may be grounds for termination of the contract.

<hr style="border: none; border-top: 1px solid black;"/> Name of Subrecipient / Contractor / Consultant (Type or Print)	<hr style="border: none; border-top: 1px solid black;"/> Program Title (Type or Print)
<hr style="border: none; border-top: 1px solid black;"/> Name of Certifying Official (Type or Print)	<hr style="border: none; border-top: 1px solid black;"/> Signature
<hr style="border: none; border-top: 1px solid black;"/> Title of Certifying Official (Type or Print)	<hr style="border: none; border-top: 1px solid black;"/> Date (Type or Print)



**SCHEDULE A-1**  
*Tax Classification: Sales tax shall be included in unit prices*

<b>ITEM NO.</b>	<b>ITEM DESCRIPTION</b>	<b>ESTIMATED QUANTITIES</b>	<b>UNIT PRICE</b>	<b>TOTAL</b>
1	ROADWAY EXCAVATION INCL. HAUL	392.00 CY	\$ 66.50	\$ 26,068.00
2	REMOVE UNSUITABLE FOUNDATION MATERIAL	10.00 CY	\$ 76.00	\$ 760.00
3	REPLACE UNSUITABLE FOUNDATION MATERIAL	10.00 CY	\$ 162.00	\$ 1,620.00
4	PREPARATION OF UNTREATED ROADWAY	895.00 SY	\$ 9.00	\$ 8,055.00
5	CRUSHED SURFACING TOP COURSE	100.00 CY	\$ 78.00	\$ 7,800.00
6	CRUSHED SURFACING BASE COURSE	150.00 CY	\$ 68.00	\$ 10,200.00
7	CSTC FOR SIDEWALK AND DRIVEWAYS	18.00 CY	\$ 185.00	\$ 3,330.00
8	HMA CL. 1/2 IN. MEDIUM TRAFFIC, 5 INCH THICK	895.00 SY	\$ 40.40	\$ 36,158.00
9	JOB MIX COMPLIANCE PRICE ADJUSTMENT	1.00 EST	\$ (1.00)	\$ (1.00)
10	COMPACTION PRICE ADJUSTMENT	3,132.50 EST	\$ 1.00	\$ 3,132.50
11	TOPSOIL FOR BIO-INFILTRATION SWALES, 12 INCH THICK INCL. SE	303.00 SY	\$ 28.00	\$ 8,484.00
12	CONSTRUCT BIO-INFILTRATION SWALE	303.00 SY	\$ 191.00	\$ 57,873.00
13	SWALE DRAIN PAD	6.00 EA	\$ 263.00	\$ 1,578.00

14	CURB DROP INLET	6.00 EA	\$	319.00	\$	1,914.00
15	CEMENT CONCRETE CURB AND GUTTER	333.00 LF	\$	49.60	\$	16,516.80
16	CEMENT CONCRETE DRIVEWAY	48.00 SY	\$	108.00	\$	5,184.00
17	CEMENT CONCRETE SIDEWALK	281.00 SY	\$	84.50	\$	23,744.50
18	RAMP DETECTABLE WARNING	8.00 SF	\$	39.00	\$	312.00
19	SIGNING, PERMANENT - CONTRACTOR MANUFACTURED SIGNS	1.00 LS	\$	2,350.00	\$	2,350.00
20	PAVEMENT MARKING - PAINT	30.00 SF	\$	34.60	\$	1,038.00
<b>Schedule A-1 Subtotal</b>					\$	<u>216,116.80</u>

**SCHEDULE A-2**  
*Tax Classification: Sales tax shall NOT be included in unit prices*

ITEM NO.	ITEM DESCRIPTION	ESTIMATED QUANTITIES	UNIT PRICE	TOTAL
21	ADA FEATURES SURVEYING	1.00 LS	\$ 3,300.00	\$ 3,300.00
22	RECORD DRAWINGS	1.00 LS	\$ 2,000.00	\$ 2,000.00
23	REIMBURSEMENT OF THIRD PARTY DAMAGE	1.00 EST	\$ 1.00	\$ 1.00
24	SPCC PLAN	1.00 LS	\$ 7,000.00	\$ 7,000.00
25	POTHOLING	10.00 EA	\$ 790.00	\$ 7,900.00
26	TYPE B PROGRESS SCHEDULE	1.00 LS	\$ 4,000.00	\$ 4,000.00
27	MOBILIZATION	1.00 LS	\$ 366,000.00	\$ 366,000.00
28	PROJECT TEMPORARY TRAFFIC CONTROL	1.00 LS	\$ 21,000.00	\$ 21,000.00
29	WORK ZONE SAFETY CONTINGENCY	5,000.00 FA	\$ 1.00	\$ 5,000.00
30	SPECIAL SIGNS	95.00 SF	\$ 22.25	\$ 2,113.75
31	TYPE III BARRICADE	13.00 EA	\$ 106.00	\$ 1,378.00
32	CLEARING AND GRUBBING	1.00 LS	\$ 3,590.00	\$ 3,590.00
33	TREE ROOT TREATMENT	1.00 EA	\$ 1,060.00	\$ 1,060.00
34	TREE PROTECTION ZONE	1.00 EA	\$ 420.00	\$ 420.00

35	REMOVE TREE, CLASS I	5.00 EA	\$	550.00	\$	2,750.00
36	REMOVE TREE, CLASS II	9.00 EA	\$	1,720.00	\$	15,480.00
37	TREE PRUNING	1.00 EA	\$	1,060.00	\$	1,060.00
38	REMOVAL OF STRUCTURE AND OBSTRUCTION	1.00 LS	\$	4,000.00	\$	4,000.00
39	SAWCUTTING FLEXIBLE PAVEMENT	2,445.00 LFI	\$	1.12	\$	2,738.40
40	ROADWAY EXCAVATION INCL. HAUL	99.00 CY	\$	51.30	\$	5,078.70
41	PREPARATION OF UNTREATED ROADWAY	546.00 SY	\$	10.00	\$	5,460.00
42	EXCAVATION, GRADING AND SHAPING	1.00 LS	\$	29,500.00	\$	29,500.00
43	STRUCTURE EXCAVATION CLASS A INCL. HAUL	1.00 LS	\$	33,500.00	\$	33,500.00
44	CONTROLLED DENSITY FILL	20.00 CY	\$	295.00	\$	5,900.00
45	DEWATERING	1.00 LS	\$	28,000.00	\$	28,000.00
46	CRUSHED SURFACING TOP COURSE	57.00 CY	\$	96.00	\$	5,472.00
47	CSTC FOR SIDEWALK AND DRIVEWAYS	13.00 CY	\$	187.00	\$	2,431.00
48	HMA CL. 1/2 IN. MEDIUM TRAFFIC, 3 INCH THICK	546.00 SY	\$	23.50	\$	12,831.00
49	SOIL RESIDUAL HERBICIDE	1,441.00 SY	\$	0.45	\$	648.45
50	JOB MIX COMPLIANCE PRICE ADJUSTMENT	1.00 EST	\$	(1.00)	\$	(1.00)

51	COMPACTION PRICE ADJUSTMENT	955.50 EST	\$	1.00	\$	955.50
52	PLAIN AL. CULV. PIPE 0.135 IN. TH. 12 IN. DIA.	36.00 LF	\$	74.00	\$	2,664.00
53	ADJUST EXISTING VALVE BOX, MON, OR CO IN ASPHALT	6.00 EA	\$	445.00	\$	2,670.00
54	ADJUST EXISTING MH, CB, DW, OR INLET IN ASPHALT	2.00 EA	\$	670.00	\$	1,340.00
55	CLEANING EXISTING DRAINAGE STRUCTURE	2.00 EA	\$	915.00	\$	1,830.00
56	REMOVE UNSUITABLE PIPE FOUNDATION MATERIAL	10.00 CY	\$	80.00	\$	800.00
57	REPLACE UNSUITABLE PIPE FOUNDATION MATERIAL	10.00 CY	\$	45.00	\$	450.00
58	TRENCH SAFETY SYSTEM	1.00 LS	\$	1,000.00	\$	1,000.00
59	SIDE SEWER CLEANING AND VIDEO INSPECTION	2.00 EA	\$	1,200.00	\$	2,400.00
60	CONNECT 6 IN. DIA. SEWER PIPE TO EXISTING SEWER PIPE	1.00 EA	\$	950.00	\$	950.00
61	PLUGGING EXISTING PIPE	4.00 EA	\$	900.00	\$	3,600.00
62	TEMPORARY ADJACENT UTILITY SUPPORT	1.00 LS	\$	3,000.00	\$	3,000.00
63	ENCASE WATER/SEWER AT CROSSINGS	1.00 EA	\$	6,050.00	\$	6,050.00
64	CLEANING EXISTING SANITARY SEWERS	2.00 EA	\$	3,400.00	\$	6,800.00
65	BOOSTER STATION PIPING AND PRV	1.00 LS	\$	270,000.00	\$	270,000.00

66	DI PIPE FOR WATER MAIN 8 IN. DIA.	46.00 LF	\$	127.00	\$	5,842.00
67	DI PIPE FOR WATER MAIN 24 IN. DIA.	195.00 LF	\$	421.00	\$	82,095.00
68	DI PIPE FOR WATER MAIN 30 IN. DIA.	541.00 LF	\$	1,100.00	\$	595,100.00
69	DI PIPE FOR WATER MAIN 36 IN. DIA.	93.00 LF	\$	1,145.00	\$	106,485.00
70	INSTALL JOINT RESTRAINT ON EXISTING 24 IN. DIA. WM	5.00 EA	\$	865.00	\$	4,325.00
71	INSTALL JOINT RESTRAINT ON EXISTING 30 IN. DIA. WM	4.00 EA	\$	865.00	\$	3,460.00
72	BLOWOFF ASSEMBLY (Y-105)	1.00 EA	\$	10,500.00	\$	10,500.00
73	BLOWOFF ASSEMBLY (Y-105A)	4.00 EA	\$	10,800.00	\$	43,200.00
74	GATE VALVE 8 IN.	2.00 EA	\$	3,150.00	\$	6,300.00
75	BUTTERFLY VALVE 24 IN.	11.00 EA	\$	2,400.00	\$	26,400.00
76	BUTTERFLY VALVE 30 IN.	4.00 EA	\$	4,100.00	\$	16,400.00
77	BUTTERFLY VALVE 36 IN.	1.00 EA	\$	4,700.00	\$	4,700.00
78	COMB. AIR RELEASE/AIR VAC. VALVE ASSEMBLY	4.00 EA	\$	8,200.00	\$	32,800.00
79	HYDRANT ASSEMBLY	1.00 EA	\$	10,700.00	\$	10,700.00
80	SIDE SEWER PIPE 6 IN. DIA.	152.00 LF	\$	93.00	\$	14,136.00
81	SIDE SEWER PERMIT	1.00 EA	\$	100.00	\$	100.00

82	SEWER CLEANOUT	4.00 EA	\$	1,450.00	\$	5,800.00
83	ESC LEAD	1.00 LS	\$	1,000.00	\$	1,000.00
84	INLET PROTECTION	2.00 EA	\$	120.00	\$	240.00
85	TOPSOIL TYPE A, 4 INCH THICK	1,001.00 SY	\$	10.00	\$	10,010.00
86	BARK OR WOOD CHIP MULCH	7.00 CY	\$	117.00	\$	819.00
87	ROCK MULCH - ROUND RIVER ROCK	60.00 CY	\$	178.00	\$	10,680.00
88	ROCK MULCH - ANGULAR BASALT	11.00 CY	\$	147.00	\$	1,617.00
89	ROCK MULCH - CSTC	173.00 CY	\$	112.00	\$	19,376.00
90	HYDROSEEDING	1,027.00 SY	\$	2.50	\$	2,567.50
91	2 INCH CALIPER DECIDUOUS TREE	6.00 EA	\$	524.00	\$	3,144.00
92	CEMENT CONCRETE MOW STRIP, 6 IN. X 6 IN.	258.00 LF	\$	42.00	\$	10,836.00
93	TOPSOIL FOR BIO-INFILTRATION SWALES, 12 INCH THICK INCL. SE	577.00 SY	\$	28.00	\$	16,156.00
94	CONSTRUCT BIO-INFILTRATION SWALE	577.00 SY	\$	14.00	\$	8,078.00
95	LANDSCAPE BOULDERS, FIVE MAN	14.00 EA	\$	255.00	\$	3,570.00
96	IRRIGATION SYSTEM	1.00 LS	\$	33,000.00	\$	33,000.00

97	4 IN. PVC IRRIGATION SLEEVE	57.00 LF	\$	44.00	\$	2,508.00
98	CHAIN LINK FENCE TYPE 3	182.00 LF	\$	59.00	\$	10,738.00
99	CLASSIFICATION AND PROTECTION OF SURVEY MONUMENTS	1.00 LS	\$	3,900.00	\$	3,900.00
100	REFERENCE AND REESTABLISH SURVEY MONUMENT	1.00 EA	\$	2,000.00	\$	2,000.00
101	PUMPING SYSTEM	1.00 LS	\$	524,700.00	\$	524,700.00
102	PUMP BARRELS (CANS) 36 IN DIAM	1.00 LS	\$	203,000.00	\$	203,000.00
103	PUMPS & SYSTEM STARTUP & TESTING	1.00 LS	\$	21,000.00	\$	21,000.00
104	BOOSTER STATION BUILDING	1.00 LS	\$	714,000.00	\$	714,000.00
105	GENERAL ELECTRICAL AND LIGHTING	1.00 LS	\$	238,000.00	\$	238,000.00
106	FLOW METER	1.00 LS	\$	131,000.00	\$	131,000.00
107	POWER GENERATION	1.00 LS	\$	180,000.00	\$	180,000.00
108	MOTOR CONTROL CENTER	1.00 LS	\$	240,000.00	\$	240,000.00
109	BUILDING HVAC AND CONTROLS	1.00 LS	\$	115,000.00	\$	115,000.00
110	PLUMBING SYSTEM	1.00 LS	\$	111,000.00	\$	111,000.00
111	CHLORINE ANALYZER AND PRESSURE GAUGE ASSEMBLY	1.00 LS	\$	12,000.00	\$	12,000.00
<b>Schedule A-2 Subtotal</b>					\$	<u>4,482,403.30</u>



---

**Summary of Bid Items**

**Bid Total** \$ 4,698,520.10

**City Of Spokane**  
**Engineering Services Department**  
**\*\*\*Bid Tabulation\*\*\***

**Project Number**      **2018102**

**Project Description**      Plains System New Booster

**Original Date**

10/21/2024 3:12:00 PM

<i>Project Number: 2018102</i>			<i>Engineer's Estimate</i>		APOLLO, INC. (Submitted)		DW EXCAVATING INC (Submitted)		HALME CONSTRUCTION INC (Submitted)	
<i>Item No</i>	<i>Bid Item Description</i>	<i>Est Qty</i>	<i>Unit Price</i>	<i>Amount</i>	<i>Unit Price</i>	<i>Amount</i>	<i>Unit Price</i>	<i>Amount</i>	<i>Unit Price</i>	<i>Amount</i>

**Tax Classification**

<b>Schedule 01</b>		Sales tax shall be included in unit prices								
1	ROADWAY EXCAVATION INCL. HAUL	392 CY	70.00	27,440.00	66.50	\$26,068.00	37.50	\$14,700.00	34.00	\$13,328.00
2	REMOVE UNSUITABLE FOUNDATION MATERIAL	10 CY	75.00	750.00	76.00	\$760.00	37.50	\$375.00	150.00	\$1,500.00
3	REPLACE UNSUITABLE FOUNDATION MATERIAL	10 CY	150.00	1,500.00	162.00	\$1,620.00	70.00	\$700.00	139.00	\$1,390.00
4	PREPARATION OF UNTREATED ROADWAY	895 SY	7.50	6,712.50	9.00	\$8,055.00	2.50	\$2,237.50	6.00	\$5,370.00
5	CRUSHED SURFACING TOP COURSE	100 CY	125.00	12,500.00	78.00	\$7,800.00	76.00	\$7,600.00	94.00	\$9,400.00
6	CRUSHED SURFACING BASE COURSE	150 CY	125.00	18,750.00	68.00	\$10,200.00	76.00	\$11,400.00	94.00	\$14,100.00
7	CSTC FOR SIDEWALK AND DRIVEWAYS	18 CY	250.00	4,500.00	185.00	\$3,330.00	240.00	\$4,320.00	206.00	\$3,708.00
8	HMA CL. 1/2 IN. MEDIUM TRAFFIC, 5 INCH THICK	895 SY	70.00	62,650.00	40.40	\$36,158.00	39.20	\$35,084.00	42.00	\$37,590.00
9	JOB MIX COMPLIANCE PRICE ADJUSTMENT	1 EST	(1.00)	(1.00)	(1.00)	(\$1.00)	(1.00)	(\$1.00)	(1.00)	(\$1.00)
10	COMPACTION PRICE ADJUSTMENT	3133 EST	1.00	3,132.50	1.00	\$3,132.50	1.00	\$3,132.50	1.00	\$3,132.50
11	TOPSOIL FOR BIO-INFILTRATION SWALES, 12 INCH THICK INCL. SE	303 SY	50.00	15,150.00	28.00	\$8,484.00	18.00	\$5,454.00	19.00	\$5,757.00
12	CONSTRUCT BIO-INFILTRATION SWALE	303 SY	40.00	12,120.00	191.00	\$57,873.00	23.00	\$6,969.00	35.00	\$10,605.00
13	SWALE DRAIN PAD	6 EA	1,500.00	9,000.00	263.00	\$1,578.00	81.00	\$486.00	86.00	\$516.00
14	CURB DROP INLET	6 EA	250.00	1,500.00	319.00	\$1,914.00	135.00	\$810.00	143.00	\$858.00
15	CEMENT CONCRETE CURB AND GUTTER	333 LF	50.00	16,650.00	49.60	\$16,516.80	41.00	\$13,653.00	44.00	\$14,652.00
16	CEMENT CONCRETE DRIVEWAY	48 SY	95.00	4,560.00	108.00	\$5,184.00	87.00	\$4,176.00	92.00	\$4,416.00
17	CEMENT CONCRETE SIDEWALK	281 SY	150.00	42,150.00	84.50	\$23,744.50	65.00	\$18,265.00	69.00	\$19,389.00
18	RAMP DETECTABLE WARNING	8 SF	40.00	320.00	39.00	\$312.00	38.00	\$304.00	40.00	\$320.00
19	SIGNING, PERMANENT - CONTRACTOR MANUFACTURED SIGNS	1 LS	2,000.00	2,000.00	2,350.00	\$2,350.00	2,300.00	\$2,300.00	3,000.00	\$3,000.00
20	PAVEMENT MARKING - PAINT	30 SF	10.00	300.00	34.60	\$1,038.00	34.00	\$1,020.00	36.00	\$1,080.00

**Tax Classification**

<b>Schedule 02</b>		Sales tax shall NOT be included in unit prices								
21	ADA FEATURES SURVEYING	1 LS	6,000.00	6,000.00	3,300.00	\$3,300.00	566.00	\$566.00	2,294.00	\$2,294.00
22	RECORD DRAWINGS	1 LS	10,000.00	10,000.00	2,000.00	\$2,000.00	10,000.00	\$10,000.00	5,000.00	\$5,000.00
23	REIMBURSEMENT OF THIRD PARTY DAMAGE	1 EST	1.00	1.00	1.00	\$1.00	1.00	\$1.00	1.00	\$1.00
24	SPCC PLAN	1 LS	2,000.00	2,000.00	7,000.00	\$7,000.00	100.00	\$100.00	2,500.00	\$2,500.00

**City Of Spokane**  
**Engineering Services Department**  
**\*\*\*Bid Tabulation\*\*\***

<b>Project Number: 2018102</b>			<b>Engineer's Estimate</b>		CLEARWATER CONSTRUCTION & MANAGEMENT (Submitted)		BIG SKY ID CORP (Submitted)		S & L UNDERGROUND INC (Submitted)	
Item No	Bid Item Description	Est Qty	Unit Price	Amount	Unit Price	Amount	Unit Price	Amount	Unit Price	Amount

**Tax Classification**

<b>Schedule 01</b>		Sales tax shall be included in unit prices								
1	ROADWAY EXCAVATION INCL. HAUL	392 CY	70.00	27,440.00	127.55	\$49,999.60	40.00	\$15,680.00	26.00	\$10,192.00
2	REMOVE UNSUITABLE FOUNDATION MATERIAL	10 CY	75.00	750.00	200.00	\$2,000.00	75.00	\$750.00	48.00	\$480.00
3	REPLACE UNSUITABLE FOUNDATION MATERIAL	10 CY	150.00	1,500.00	280.00	\$2,800.00	148.50	\$1,485.00	38.00	\$380.00
4	PREPARATION OF UNTREATED ROADWAY	895 SY	7.50	6,712.50	25.14	\$22,500.30	2.50	\$2,237.50	18.00	\$16,110.00
5	CRUSHED SURFACING TOP COURSE	100 CY	125.00	12,500.00	180.00	\$18,000.00	77.50	\$7,750.00	46.00	\$4,600.00
6	CRUSHED SURFACING BASE COURSE	150 CY	125.00	18,750.00	185.00	\$27,750.00	65.00	\$9,750.00	44.00	\$6,600.00
7	CSTC FOR SIDEWALK AND DRIVEWAYS	18 CY	250.00	4,500.00	250.00	\$4,500.00	706.00	\$12,708.00	185.00	\$3,330.00
8	HMA CL. 1/2 IN. MEDIUM TRAFFIC, 5 INCH THICK	895 SY	70.00	62,650.00	46.00	\$41,170.00	44.50	\$39,827.50	42.00	\$37,590.00
9	JOB MIX COMPLIANCE PRICE ADJUSTMENT	1 EST	(1.00)	(1.00)	(1.00)	(\$1.00)	(1.00)	(\$1.00)	(1.00)	(\$1.00)
10	COMPACTION PRICE ADJUSTMENT	3133 EST	1.00	3,132.50	1.00	\$3,132.50	1.00	\$3,132.50	1.00	\$3,132.50
11	TOPSOIL FOR BIO-INFILTRATION SWALES, 12 INCH THICK INCL. SE	303 SY	50.00	15,150.00	20.00	\$6,060.00	39.00	\$11,817.00	22.00	\$6,666.00
12	CONSTRUCT BIO-INFILTRATION SWALE	303 SY	40.00	12,120.00	46.00	\$13,938.00	13.00	\$3,939.00	26.00	\$7,878.00
13	SWALE DRAIN PAD	6 EA	1,500.00	9,000.00	380.00	\$2,280.00	310.00	\$1,860.00	250.00	\$1,500.00
14	CURB DROP INLET	6 EA	250.00	1,500.00	430.00	\$2,580.00	350.00	\$2,100.00	300.00	\$1,800.00
15	CEMENT CONCRETE CURB AND GUTTER	333 LF	50.00	16,650.00	50.00	\$16,650.00	47.00	\$15,651.00	40.00	\$13,320.00
16	CEMENT CONCRETE DRIVEWAY	48 SY	95.00	4,560.00	100.00	\$4,800.00	111.00	\$5,328.00	95.00	\$4,560.00
17	CEMENT CONCRETE SIDEWALK	281 SY	150.00	42,150.00	78.00	\$21,918.00	76.00	\$21,356.00	70.00	\$19,670.00
18	RAMP DETECTABLE WARNING	8 SF	40.00	320.00	44.00	\$352.00	28.50	\$228.00	40.00	\$320.00
19	SIGNING, PERMANENT - CONTRACTOR MANUFACTURED SIGNS	1 LS	2,000.00	2,000.00	3,500.00	\$3,500.00	2,570.00	\$2,570.00	3,000.00	\$3,000.00
20	PAVEMENT MARKING - PAINT	30 SF	10.00	300.00	66.00	\$1,980.00	38.00	\$1,140.00	35.00	\$1,050.00

**Tax Classification**

<b>Schedule 02</b>		Sales tax shall NOT be included in unit prices								
21	ADA FEATURES SURVEYING	1 LS	6,000.00	6,000.00	2,000.00	\$2,000.00	2,400.00	\$2,400.00	25,000.00	\$25,000.00
22	RECORD DRAWINGS	1 LS	10,000.00	10,000.00	10,000.00	\$10,000.00	10,000.00	\$10,000.00	10,000.00	\$10,000.00
23	REIMBURSEMENT OF THIRD PARTY DAMAGE	1 EST	1.00	1.00	1.00	\$1.00	1.00	\$1.00	1.00	\$1.00
24	SPCC PLAN	1 LS	2,000.00	2,000.00	1,500.00	\$1,500.00	1,500.00	\$1,500.00	10,000.00	\$10,000.00

**City Of Spokane**  
**Engineering Services Department**  
**\*\*\*Bid Tabulation\*\*\***

<b>Project Number: 2018102</b>			<b>Engineer's Estimate</b>		<b>APOLLO, INC. (Submitted)</b>		<b>DW EXCAVATING INC (Submitted)</b>		<b>HALME CONSTRUCTION INC (Submitted)</b>	
<b>Item No</b>	<b>Bid Item Description</b>	<b>Est Qty</b>	<b>Unit Price</b>	<b>Amount</b>	<b>Unit Price</b>	<b>Amount</b>	<b>Unit Price</b>	<b>Amount</b>	<b>Unit Price</b>	<b>Amount</b>
25	POTHOLING	10 EA	1,000.00	10,000.00	790.00	\$7,900.00	536.00	\$5,360.00	854.00	\$8,540.00
26	TYPE B PROGRESS SCHEDULE	1 LS	7,500.00	7,500.00	4,000.00	\$4,000.00	100.00	\$100.00	5,000.00	\$5,000.00
27	MOBILIZATION	1 LS	416,803.95	416,803.95	366,000.00	\$366,000.00	429,000.00	\$429,000.00	468,000.00	\$468,000.00
28	PROJECT TEMPORARY TRAFFIC CONTROL	1 LS	25,000.00	25,000.00	21,000.00	\$21,000.00	59,000.00	\$59,000.00	75,000.00	\$75,000.00
29	WORK ZONE SAFETY CONTINGENCY	5000 FA	1.00	5,000.00	1.00	\$5,000.00	1.00	\$5,000.00	1.00	\$5,000.00
30	SPECIAL SIGNS	95 SF	25.00	2,375.00	22.25	\$2,113.75	31.00	\$2,945.00	32.00	\$3,040.00
31	TYPE III BARRICADE	13 EA	300.00	3,900.00	106.00	\$1,378.00	163.00	\$2,119.00	172.00	\$2,236.00
32	CLEARING AND GRUBBING	1 LS	15,000.00	15,000.00	3,590.00	\$3,590.00	11,400.00	\$11,400.00	20,000.00	\$20,000.00
33	TREE ROOT TREATMENT	1 EA	850.00	850.00	1,060.00	\$1,060.00	410.00	\$410.00	430.00	\$430.00
34	TREE PROTECTION ZONE	1 EA	300.00	300.00	420.00	\$420.00	352.00	\$352.00	373.00	\$373.00
35	REMOVE TREE, CLASS I	5 EA	1,200.00	6,000.00	550.00	\$2,750.00	265.00	\$1,325.00	281.00	\$1,405.00
36	REMOVE TREE, CLASS II	9 EA	1,700.00	15,300.00	1,720.00	\$15,480.00	287.00	\$2,583.00	304.00	\$2,736.00
37	TREE PRUNING	1 EA	325.00	325.00	1,060.00	\$1,060.00	406.00	\$406.00	430.00	\$430.00
38	REMOVAL OF STRUCTURE AND OBSTRUCTION	1 LS	800.00	800.00	4,000.00	\$4,000.00	3,200.00	\$3,200.00	10,151.00	\$10,151.00
39	SAWCUTTING FLEXIBLE PAVEMENT	2445 LFI	2.00	4,890.00	1.12	\$2,738.40	0.40	\$978.00	1.00	\$2,445.00
40	ROADWAY EXCAVATION INCL. HAUL	99 CY	70.00	6,930.00	51.30	\$5,078.70	37.50	\$3,712.50	34.00	\$3,366.00
41	PREPARATION OF UNTREATED ROADWAY	546 SY	7.50	4,095.00	10.00	\$5,460.00	2.50	\$1,365.00	6.00	\$3,276.00
42	EXCAVATION, GRADING AND SHAPING	1 LS	10,000.00	10,000.00	29,500.00	\$29,500.00	12,300.00	\$12,300.00	30,000.00	\$30,000.00
43	STRUCTURE EXCAVATION CLASS A INCL. HAUL	1 LS	30,000.00	30,000.00	33,500.00	\$33,500.00	40,500.00	\$40,500.00	20,000.00	\$20,000.00
44	CONTROLLED DENSITY FILL	20 CY	300.00	6,000.00	295.00	\$5,900.00	220.00	\$4,400.00	188.00	\$3,760.00
45	DEWATERING	1 LS	10,000.00	10,000.00	28,000.00	\$28,000.00	27,600.00	\$27,600.00	27,861.00	\$27,861.00
46	CRUSHED SURFACING TOP COURSE	57 CY	125.00	7,125.00	96.00	\$5,472.00	76.00	\$4,332.00	94.00	\$5,358.00
47	CSTC FOR SIDEWALK AND DRIVEWAYS	13 CY	250.00	3,250.00	187.00	\$2,431.00	240.00	\$3,120.00	206.00	\$2,678.00
48	HMA CL. 1/2 IN. MEDIUM TRAFFIC, 3 INCH THICK	546 SY	35.00	19,110.00	23.50	\$12,831.00	22.75	\$12,421.50	24.00	\$13,104.00
49	SOIL RESIDUAL HERBICIDE	1441 SY	1.50	2,161.50	0.45	\$648.45	0.50	\$720.50	1.00	\$1,441.00
50	JOB MIX COMPLIANCE PRICE ADJUSTMENT	1 EST	(1.00)	(1.00)	(1.00)	(\$1.00)	(1.00)	(\$1.00)	(1.00)	(\$1.00)
51	COMPACTION PRICE ADJUSTMENT	956 EST	1.00	955.50	1.00	\$955.50	1.00	\$955.50	1.00	\$955.50
52	PLAIN AL. CULV. PIPE 0.135 IN. TH. 12 IN. DIA.	36 LF	55.00	1,980.00	74.00	\$2,664.00	106.00	\$3,816.00	79.00	\$2,844.00
53	ADJUST EXISTING VALVE BOX, MON, OR CO IN ASPHALT	6 EA	700.00	4,200.00	445.00	\$2,670.00	780.00	\$4,680.00	527.00	\$3,162.00
54	ADJUST EXISTING MH, CB, DW, OR INLET IN ASPHALT	2 EA	700.00	1,400.00	670.00	\$1,340.00	915.00	\$1,830.00	530.00	\$1,060.00
55	CLEANING EXISTING DRAINAGE STRUCTURE	2 EA	1,000.00	2,000.00	915.00	\$1,830.00	705.00	\$1,410.00	688.00	\$1,376.00

**City Of Spokane**  
**Engineering Services Department**  
**\*\*\*Bid Tabulation\*\*\***

<i>Project Number: 2018102</i>			<i>Engineer's Estimate</i>		CLEARWATER CONSTRUCTION & MANAGEMENT (Submitted)		BIG SKY ID CORP (Submitted)		S & L UNDERGROUND INC (Submitted)	
<i>Item No</i>	<i>Bid Item Description</i>	<i>Est Qty</i>	<i>Unit Price</i>	<i>Amount</i>	<i>Unit Price</i>	<i>Amount</i>	<i>Unit Price</i>	<i>Amount</i>	<i>Unit Price</i>	<i>Amount</i>
25	POTHOLING	10 EA	1,000.00	10,000.00	600.00	\$6,000.00	1,000.00	\$10,000.00	800.00	\$8,000.00
26	TYPE B PROGRESS SCHEDULE	1 LS	7,500.00	7,500.00	2,500.00	\$2,500.00	1,200.00	\$1,200.00	10,000.00	\$10,000.00
27	MOBILIZATION	1 LS	416,803.95	416,803.95	440,000.00	\$440,000.00	300,000.00	\$300,000.00	500,000.00	\$500,000.00
28	PROJECT TEMPORARY TRAFFIC CONTROL	1 LS	25,000.00	25,000.00	12,000.00	\$12,000.00	26,500.00	\$26,500.00	35,000.00	\$35,000.00
29	WORK ZONE SAFETY CONTINGENCY	5000 FA	1.00	5,000.00	1.00	\$5,000.00	1.00	\$5,000.00	1.00	\$5,000.00
30	SPECIAL SIGNS	95 SF	25.00	2,375.00	17.00	\$1,615.00	31.00	\$2,945.00	35.00	\$3,325.00
31	TYPE III BARRICADE	13 EA	300.00	3,900.00	123.00	\$1,599.00	125.00	\$1,625.00	110.00	\$1,430.00
32	CLEARING AND GRUBBING	1 LS	15,000.00	15,000.00	23,000.00	\$23,000.00	22,000.00	\$22,000.00	25,000.00	\$25,000.00
33	TREE ROOT TREATMENT	1 EA	850.00	850.00	450.00	\$450.00	1,150.00	\$1,150.00	400.00	\$400.00
34	TREE PROTECTION ZONE	1 EA	300.00	300.00	400.00	\$400.00	250.00	\$250.00	350.00	\$350.00
35	REMOVE TREE, CLASS I	5 EA	1,200.00	6,000.00	300.00	\$1,500.00	350.00	\$1,750.00	265.00	\$1,325.00
36	REMOVE TREE, CLASS II	9 EA	1,700.00	15,300.00	325.00	\$2,925.00	1,900.00	\$17,100.00	290.00	\$2,610.00
37	TREE PRUNING	1 EA	325.00	325.00	425.00	\$425.00	1,100.00	\$1,100.00	400.00	\$400.00
38	REMOVAL OF STRUCTURE AND OBSTRUCTION	1 LS	800.00	800.00	4,000.00	\$4,000.00	4,300.00	\$4,300.00	25,000.00	\$25,000.00
39	SAWCUTTING FLEXIBLE PAVEMENT	2445 LFI	2.00	4,890.00	1.25	\$3,056.25	3.00	\$7,335.00	3.00	\$7,335.00
40	ROADWAY EXCAVATION INCL. HAUL	99 CY	70.00	6,930.00	24.00	\$2,376.00	53.00	\$5,247.00	42.00	\$4,158.00
41	PREPARATION OF UNTREATED ROADWAY	546 SY	7.50	4,095.00	9.00	\$4,914.00	7.00	\$3,822.00	18.00	\$9,828.00
42	EXCAVATION, GRADING AND SHAPING	1 LS	10,000.00	10,000.00	35,000.00	\$35,000.00	9,550.00	\$9,550.00	42,000.00	\$42,000.00
43	STRUCTURE EXCAVATION CLASS A INCL. HAUL	1 LS	30,000.00	30,000.00	58,000.00	\$58,000.00	44,500.00	\$44,500.00	32,000.00	\$32,000.00
44	CONTROLLED DENSITY FILL	20 CY	300.00	6,000.00	600.00	\$12,000.00	330.00	\$6,600.00	325.00	\$6,500.00
45	DEWATERING	1 LS	10,000.00	10,000.00	6,200.00	\$6,200.00	21,000.00	\$21,000.00	25,000.00	\$25,000.00
46	CRUSHED SURFACING TOP COURSE	57 CY	125.00	7,125.00	180.00	\$10,260.00	58.00	\$3,306.00	48.00	\$2,736.00
47	CSTC FOR SIDEWALK AND DRIVEWAYS	13 CY	250.00	3,250.00	240.00	\$3,120.00	114.00	\$1,482.00	200.00	\$2,600.00
48	HMA CL. 1/2 IN. MEDIUM TRAFFIC, 3 INCH THICK	546 SY	35.00	19,110.00	23.00	\$12,558.00	25.00	\$13,650.00	32.00	\$17,472.00
49	SOIL RESIDUAL HERBICIDE	1441 SY	1.50	2,161.50	0.50	\$720.50	0.50	\$720.50	2.00	\$2,882.00
50	JOB MIX COMPLIANCE PRICE ADJUSTMENT	1 EST	(1.00)	(1.00)	(1.00)	(\$1.00)	(1.00)	(\$1.00)	1.00	\$1.00
51	COMPACTION PRICE ADJUSTMENT	956 EST	1.00	955.50	1.00	\$955.50	1.00	\$955.50	1.00	\$955.50
52	PLAIN AL. CULV. PIPE 0.135 IN. TH. 12 IN. DIA.	36 LF	55.00	1,980.00	100.00	\$3,600.00	80.00	\$2,880.00	95.00	\$3,420.00
53	ADJUST EXISTING VALVE BOX, MON, OR CO IN ASPHALT	6 EA	700.00	4,200.00	200.00	\$1,200.00	600.00	\$3,600.00	200.00	\$1,200.00
54	ADJUST EXISTING MH, CB, DW, OR INLET IN ASPHALT	2 EA	700.00	1,400.00	375.00	\$750.00	800.00	\$1,600.00	400.00	\$800.00
55	CLEANING EXISTING DRAINAGE STRUCTURE	2 EA	1,000.00	2,000.00	1,250.00	\$2,500.00	700.00	\$1,400.00	800.00	\$1,600.00

**City Of Spokane**  
**Engineering Services Department**  
**\*\*\*Bid Tabulation\*\*\***

<b>Project Number: 2018102</b>			<b>Engineer's Estimate</b>		<b>APOLLO, INC. (Submitted)</b>		<b>DW EXCAVATING INC (Submitted)</b>		<b>HALME CONSTRUCTION INC (Submitted)</b>	
<b>Item No</b>	<b>Bid Item Description</b>	<b>Est Qty</b>	<b>Unit Price</b>	<b>Amount</b>	<b>Unit Price</b>	<b>Amount</b>	<b>Unit Price</b>	<b>Amount</b>	<b>Unit Price</b>	<b>Amount</b>
56	REMOVE UNSUITABLE PIPE FOUNDATION MATERIAL	10 CY	50.00	500.00	80.00	\$800.00	39.00	\$390.00	74.00	\$740.00
57	REPLACE UNSUITABLE PIPE FOUNDATION MATERIAL	10 CY	80.00	800.00	45.00	\$450.00	52.00	\$520.00	102.00	\$1,020.00
58	TRENCH SAFETY SYSTEM	1 LS	25,000.00	25,000.00	1,000.00	\$1,000.00	6,400.00	\$6,400.00	1,166.00	\$1,166.00
59	SIDE SEWER CLEANING AND VIDEO INSPECTION	2 EA	1,500.00	3,000.00	1,200.00	\$2,400.00	1,100.00	\$2,200.00	1,147.00	\$2,294.00
60	CONNECT 6 IN. DIA. SEWER PIPE TO EXISTING SEWER PIPE	1 EA	1,000.00	1,000.00	950.00	\$950.00	5,300.00	\$5,300.00	4,662.00	\$4,662.00
61	PLUGGING EXISTING PIPE	4 EA	500.00	2,000.00	900.00	\$3,600.00	292.00	\$1,168.00	369.00	\$1,476.00
62	TEMPORARY ADJACENT UTILITY SUPPORT	1 LS	2,000.00	2,000.00	3,000.00	\$3,000.00	6,400.00	\$6,400.00	10,871.00	\$10,871.00
63	ENCASE WATER/SEWER AT CROSSINGS	1 EA	4,000.00	4,000.00	6,050.00	\$6,050.00	5,150.00	\$5,150.00	3,053.00	\$3,053.00
64	CLEANING EXISTING SANITARY SEWERS	2 EA	1,500.00	3,000.00	3,400.00	\$6,800.00	1,100.00	\$2,200.00	1,262.00	\$2,524.00
65	BOOSTER STATION PIPING AND PRV	1 LS	200,000.00	200,000.00	270,000.00	\$270,000.00	342,800.00	\$342,800.00	300,000.00	\$300,000.00
66	DI PIPE FOR WATER MAIN 8 IN. DIA.	46 LF	400.00	18,400.00	127.00	\$5,842.00	187.00	\$8,602.00	312.00	\$14,352.00
67	DI PIPE FOR WATER MAIN 24 IN. DIA.	195 LF	750.00	146,250.00	421.00	\$82,095.00	495.00	\$96,525.00	464.00	\$90,480.00
68	DI PIPE FOR WATER MAIN 30 IN. DIA.	541 LF	900.00	486,900.00	1,100.00	\$595,100.00	1,195.00	\$646,495.00	1,133.00	\$612,953.00
69	DI PIPE FOR WATER MAIN 36 IN. DIA.	93 LF	1,100.00	102,300.00	1,145.00	\$106,485.00	1,200.00	\$111,600.00	1,281.00	\$119,133.00
70	INSTALL JOINT RESTRAINT ON EXISTING 24 IN. DIA. WM	5 EA	800.00	4,000.00	865.00	\$4,325.00	2,005.00	\$10,025.00	1,078.00	\$5,390.00
71	INSTALL JOINT RESTRAINT ON EXISTING 30 IN. DIA. WM	4 EA	800.00	3,200.00	865.00	\$3,460.00	2,005.00	\$8,020.00	1,348.00	\$5,392.00
72	BLOWOFF ASSEMBLY (Y-105)	1 EA	10,000.00	10,000.00	10,500.00	\$10,500.00	9,700.00	\$9,700.00	27,029.00	\$27,029.00
73	BLOWOFF ASSEMBLY (Y-105A)	4 EA	10,000.00	40,000.00	10,800.00	\$43,200.00	10,000.00	\$40,000.00	6,249.00	\$24,996.00
74	GATE VALVE 8 IN.	2 EA	5,000.00	10,000.00	3,150.00	\$6,300.00	3,200.00	\$6,400.00	2,961.00	\$5,922.00
75	BUTTERFLY VALVE 24 IN.	11 EA	5,000.00	55,000.00	2,400.00	\$26,400.00	2,350.00	\$25,850.00	1,862.00	\$20,482.00
76	BUTTERFLY VALVE 30 IN.	4 EA	5,000.00	20,000.00	4,100.00	\$16,400.00	3,900.00	\$15,600.00	1,762.00	\$7,048.00
77	BUTTERFLY VALVE 36 IN.	1 EA	5,000.00	5,000.00	4,700.00	\$4,700.00	4,600.00	\$4,600.00	4,958.00	\$4,958.00
78	COMB. AIR RELEASE/AIR VAC. VALVE ASSEMBLY	4 EA	5,000.00	20,000.00	8,200.00	\$32,800.00	5,400.00	\$21,600.00	3,733.00	\$14,932.00
79	HYDRANT ASSEMBLY	1 EA	12,000.00	12,000.00	10,700.00	\$10,700.00	10,000.00	\$10,000.00	12,633.00	\$12,633.00
80	SIDE SEWER PIPE 6 IN. DIA.	152 LF	120.00	18,240.00	93.00	\$14,136.00	115.00	\$17,480.00	75.00	\$11,400.00
81	SIDE SEWER PERMIT	1 EA	40.00	40.00	100.00	\$100.00	70.00	\$70.00	58.00	\$58.00
82	SEWER CLEANOUT	4 EA	2,000.00	8,000.00	1,450.00	\$5,800.00	2,100.00	\$8,400.00	1,632.00	\$6,528.00
83	ESC LEAD	1 LS	5,000.00	5,000.00	1,000.00	\$1,000.00	4,500.00	\$4,500.00	5,247.00	\$5,247.00
84	INLET PROTECTION	2 EA	150.00	300.00	120.00	\$240.00	72.00	\$144.00	175.00	\$350.00
85	TOPSOIL TYPE A, 4 INCH THICK	1001 SY	13.00	13,013.00	10.00	\$10,010.00	7.00	\$7,007.00	7.00	\$7,007.00
86	BARK OR WOOD CHIP MULCH	7 CY	200.00	1,400.00	117.00	\$819.00	108.00	\$756.00	114.00	\$798.00

**City Of Spokane**  
**Engineering Services Department**  
**\*\*\*Bid Tabulation\*\*\***

<b>Project Number: 2018102</b>			<b>Engineer's Estimate</b>		<b>CLEARWATER CONSTRUCTION &amp; MANAGEMENT (Submitted)</b>		<b>BIG SKY ID CORP (Submitted)</b>		<b>S &amp; L UNDERGROUND INC (Submitted)</b>	
<b>Item No</b>	<b>Bid Item Description</b>	<b>Est Qty</b>	<b>Unit Price</b>	<b>Amount</b>	<b>Unit Price</b>	<b>Amount</b>	<b>Unit Price</b>	<b>Amount</b>	<b>Unit Price</b>	<b>Amount</b>
56	REMOVE UNSUITABLE PIPE FOUNDATION MATERIAL	10 CY	50.00	500.00	200.00	\$2,000.00	85.00	\$850.00	38.00	\$380.00
57	REPLACE UNSUITABLE PIPE FOUNDATION MATERIAL	10 CY	80.00	800.00	280.00	\$2,800.00	60.00	\$600.00	42.00	\$420.00
58	TRENCH SAFETY SYSTEM	1 LS	25,000.00	25,000.00	2,500.00	\$2,500.00	500.00	\$500.00	15,000.00	\$15,000.00
59	SIDE SEWER CLEANING AND VIDEO INSPECTION	2 EA	1,500.00	3,000.00	1,750.00	\$3,500.00	600.00	\$1,200.00	3,400.00	\$6,800.00
60	CONNECT 6 IN. DIA. SEWER PIPE TO EXISTING SEWER PIPE	1 EA	1,000.00	1,000.00	675.00	\$675.00	3,600.00	\$3,600.00	1,200.00	\$1,200.00
61	PLUGGING EXISTING PIPE	4 EA	500.00	2,000.00	750.00	\$3,000.00	500.00	\$2,000.00	200.00	\$800.00
62	TEMPORARY ADJACENT UTILITY SUPPORT	1 LS	2,000.00	2,000.00	5,000.00	\$5,000.00	7,500.00	\$7,500.00	20,000.00	\$20,000.00
63	ENCASE WATER/SEWER AT CROSSINGS	1 EA	4,000.00	4,000.00	12,000.00	\$12,000.00	3,800.00	\$3,800.00	8,000.00	\$8,000.00
64	CLEANING EXISTING SANITARY SEWERS	2 EA	1,500.00	3,000.00	2,000.00	\$4,000.00	720.00	\$1,440.00	4,500.00	\$9,000.00
65	BOOSTER STATION PIPING AND PRV	1 LS	200,000.00	200,000.00	370,000.00	\$370,000.00	300,000.00	\$300,000.00	500,000.00	\$500,000.00
66	DI PIPE FOR WATER MAIN 8 IN. DIA.	46 LF	400.00	18,400.00	250.00	\$11,500.00	110.00	\$5,060.00	125.00	\$5,750.00
67	DI PIPE FOR WATER MAIN 24 IN. DIA.	195 LF	750.00	146,250.00	570.00	\$111,150.00	478.00	\$93,210.00	385.00	\$75,075.00
68	DI PIPE FOR WATER MAIN 30 IN. DIA.	541 LF	900.00	486,900.00	1,400.00	\$757,400.00	1,250.00	\$676,250.00	1,100.00	\$595,100.00
69	DI PIPE FOR WATER MAIN 36 IN. DIA.	93 LF	1,100.00	102,300.00	1,400.00	\$130,200.00	1,300.00	\$120,900.00	1,200.00	\$111,600.00
70	INSTALL JOINT RESTRAINT ON EXISTING 24 IN. DIA. WM	5 EA	800.00	4,000.00	1,900.00	\$9,500.00	1,600.00	\$8,000.00	5,000.00	\$25,000.00
71	INSTALL JOINT RESTRAINT ON EXISTING 30 IN. DIA. WM	4 EA	800.00	3,200.00	3,250.00	\$13,000.00	1,600.00	\$6,400.00	6,000.00	\$24,000.00
72	BLOWOFF ASSEMBLY (Y-105)	1 EA	10,000.00	10,000.00	10,000.00	\$10,000.00	9,750.00	\$9,750.00	15,000.00	\$15,000.00
73	BLOWOFF ASSEMBLY (Y-105A)	4 EA	10,000.00	40,000.00	11,000.00	\$44,000.00	9,700.00	\$38,800.00	14,000.00	\$56,000.00
74	GATE VALVE 8 IN.	2 EA	5,000.00	10,000.00	6,500.00	\$13,000.00	3,650.00	\$7,300.00	2,800.00	\$5,600.00
75	BUTTERFLY VALVE 24 IN.	11 EA	5,000.00	55,000.00	5,100.00	\$56,100.00	2,650.00	\$29,150.00	3,400.00	\$37,400.00
76	BUTTERFLY VALVE 30 IN.	4 EA	5,000.00	20,000.00	5,200.00	\$20,800.00	4,200.00	\$16,800.00	4,600.00	\$18,400.00
77	BUTTERFLY VALVE 36 IN.	1 EA	5,000.00	5,000.00	7,000.00	\$7,000.00	4,900.00	\$4,900.00	5,800.00	\$5,800.00
78	COMB. AIR RELEASE/AIR VAC. VALVE ASSEMBLY	4 EA	5,000.00	20,000.00	4,750.00	\$19,000.00	11,000.00	\$44,000.00	8,000.00	\$32,000.00
79	HYDRANT ASSEMBLY	1 EA	12,000.00	12,000.00	10,500.00	\$10,500.00	10,500.00	\$10,500.00	9,500.00	\$9,500.00
80	SIDE SEWER PIPE 6 IN. DIA.	152 LF	120.00	18,240.00	46.00	\$6,992.00	68.00	\$10,336.00	120.00	\$18,240.00
81	SIDE SEWER PERMIT	1 EA	40.00	40.00	225.00	\$225.00	675.00	\$675.00	4,000.00	\$4,000.00
82	SEWER CLEANOUT	4 EA	2,000.00	8,000.00	750.00	\$3,000.00	1,450.00	\$5,800.00	800.00	\$3,200.00
83	ESC LEAD	1 LS	5,000.00	5,000.00	2,250.00	\$2,250.00	2,500.00	\$2,500.00	15,000.00	\$15,000.00
84	INLET PROTECTION	2 EA	150.00	300.00	600.00	\$1,200.00	230.00	\$460.00	200.00	\$400.00
85	TOPSOIL TYPE A, 4 INCH THICK	1001 SY	13.00	13,013.00	7.50	\$7,507.50	8.00	\$8,008.00	8.00	\$8,008.00
86	BARK OR WOOD CHIP MULCH	7 CY	200.00	1,400.00	120.00	\$840.00	150.00	\$1,050.00	110.00	\$770.00

**City Of Spokane**  
**Engineering Services Department**  
**\*\*\*Bid Tabulation\*\*\***

<i>Project Number: 2018102</i>			<i>Engineer's Estimate</i>		APOLLO, INC. (Submitted)		DW EXCAVATING INC (Submitted)		HALME CONSTRUCTION INC (Submitted)	
<i>Item No</i>	<i>Bid Item Description</i>	<i>Est Qty</i>	<i>Unit Price</i>	<i>Amount</i>	<i>Unit Price</i>	<i>Amount</i>	<i>Unit Price</i>	<i>Amount</i>	<i>Unit Price</i>	<i>Amount</i>
87	ROCK MULCH - ROUND RIVER ROCK	60 CY	250.00	15,000.00	178.00	\$10,680.00	77.00	\$4,620.00	82.00	\$4,920.00
88	ROCK MULCH - ANGULAR BASALT	11 CY	250.00	2,750.00	147.00	\$1,617.00	82.00	\$902.00	86.00	\$946.00
89	ROCK MULCH - CSTC	173 CY	250.00	43,250.00	112.00	\$19,376.00	74.00	\$12,802.00	79.00	\$13,667.00
90	HYDROSEEDING	1027 SY	3.00	3,081.00	2.50	\$2,567.50	3.00	\$3,081.00	3.00	\$3,081.00
91	2 INCH CALIPER DECIDUOUS TREE	6 EA	500.00	3,000.00	524.00	\$3,144.00	725.00	\$4,350.00	766.00	\$4,596.00
92	CEMENT CONCRETE MOW STRIP, 6 IN. X 6 IN.	258 LF	40.00	10,320.00	42.00	\$10,836.00	31.00	\$7,998.00	33.00	\$8,514.00
93	TOPSOIL FOR BIO-INFILTRATION SWALES, 12 INCH THICK INCL. SE	577 SY	50.00	28,850.00	28.00	\$16,156.00	18.00	\$10,386.00	19.00	\$10,963.00
94	CONSTRUCT BIO-INFILTRATION SWALE	577 SY	40.00	23,080.00	14.00	\$8,078.00	140.00	\$80,780.00	19.00	\$10,963.00
95	LANDSCAPE BOULDERS, FIVE MAN	14 EA	130.00	1,820.00	255.00	\$3,570.00	215.00	\$3,010.00	224.00	\$3,136.00
96	IRRIGATION SYSTEM	1 LS	75,000.00	75,000.00	33,000.00	\$33,000.00	19,675.00	\$19,675.00	20,843.00	\$20,843.00
97	4 IN. PVC IRRIGATION SLEEVE	57 LF	50.00	2,850.00	44.00	\$2,508.00	19.00	\$1,083.00	26.00	\$1,482.00
98	CHAIN LINK FENCE TYPE 3	182 LF	90.00	16,380.00	59.00	\$10,738.00	57.00	\$10,374.00	61.00	\$11,102.00
99	CLASSIFICATION AND PROTECTION OF SURVEY MONUMENTS	1 LS	5,000.00	5,000.00	3,900.00	\$3,900.00	3,800.00	\$3,800.00	6,000.00	\$6,000.00
100	REFERENCE AND REESTABLISH SURVEY MONUMENT	1 EA	1,500.00	1,500.00	2,000.00	\$2,000.00	325.00	\$325.00	344.00	\$344.00
101	PUMPING SYSTEM	1 LS	500,000.00	500,000.00	524,700.00	\$524,700.00	435,000.00	\$435,000.00	400,000.00	\$400,000.00
102	PUMP BARRELS (CANS) 36 IN DIAM	1 LS	200,000.00	200,000.00	203,000.00	\$203,000.00	309,000.00	\$309,000.00	330,000.00	\$330,000.00
103	PUMPS & SYSTEM STARTUP & TESTING	1 LS	50,000.00	50,000.00	21,000.00	\$21,000.00	16,500.00	\$16,500.00	25,000.00	\$25,000.00
104	BOOSTER STATION BUILDING	1 LS	810,000.00	810,000.00	714,000.00	\$714,000.00	664,000.00	\$664,000.00	800,000.00	\$800,000.00
105	GENERAL ELECTRICAL AND LIGHTING	1 LS	200,000.00	200,000.00	238,000.00	\$238,000.00	152,000.00	\$152,000.00	160,000.00	\$160,000.00
106	FLOW METER	1 LS	50,000.00	50,000.00	131,000.00	\$131,000.00	132,000.00	\$132,000.00	84,116.00	\$84,116.00
107	POWER GENERATION	1 LS	250,000.00	250,000.00	180,000.00	\$180,000.00	198,000.00	\$198,000.00	203,580.00	\$203,580.00
108	MOTOR CONTROL CENTER	1 LS	350,000.00	350,000.00	240,000.00	\$240,000.00	238,000.00	\$238,000.00	247,134.00	\$247,134.00
109	BUILDING HVAC AND CONTROLS	1 LS	175,000.00	175,000.00	115,000.00	\$115,000.00	130,000.00	\$130,000.00	100,000.00	\$100,000.00
110	PLUMBING SYSTEM	1 LS	125,000.00	125,000.00	111,000.00	\$111,000.00	95,000.00	\$95,000.00	100,000.00	\$100,000.00
111	CHLORINE ANALYZER AND PRESSURE GAUGE ASSEMBLY	1 LS	10,000.00	10,000.00	12,000.00	\$12,000.00	11,000.00	\$11,000.00	10,000.00	\$10,000.00
<b>Bid Total</b>				<b>\$5,055,158.95</b>		<b>\$4,698,520.10</b>		<b>\$4,760,580.00</b>		<b>\$4,770,213.00</b>



**City Of Spokane**  
**Engineering Services Department**  
**\*\*\*Bid Tabulation\*\*\***

<i>Project Number: 2018102</i>			<i>Engineer's Estimate</i>		CLEARWATER CONSTRUCTION & MANAGEMENT (Submitted)		BIG SKY ID CORP (Submitted)		S & L UNDERGROUND INC (Submitted)	
<i>Item No</i>	<i>Bid Item Description</i>	<i>Est Qty</i>	<i>Unit Price</i>	<i>Amount</i>	<i>Unit Price</i>	<i>Amount</i>	<i>Unit Price</i>	<i>Amount</i>	<i>Unit Price</i>	<i>Amount</i>
87	ROCK MULCH - ROUND RIVER ROCK	60 CY	250.00	15,000.00	80.00	\$4,800.00	175.00	\$10,500.00	85.00	\$5,100.00
88	ROCK MULCH - ANGULAR BASALT	11 CY	250.00	2,750.00	85.00	\$935.00	175.00	\$1,925.00	85.00	\$935.00
89	ROCK MULCH - CSTC	173 CY	250.00	43,250.00	75.00	\$12,975.00	80.00	\$13,840.00	78.00	\$13,494.00
90	HYDROSEEDING	1027 SY	3.00	3,081.00	3.00	\$3,081.00	1.90	\$1,951.30	4.00	\$4,108.00
91	2 INCH CALIPER DECIDUOUS TREE	6 EA	500.00	3,000.00	800.00	\$4,800.00	830.00	\$4,980.00	750.00	\$4,500.00
92	CEMENT CONCRETE MOW STRIP, 6 IN. X 6 IN.	258 LF	40.00	10,320.00	35.00	\$9,030.00	21.00	\$5,418.00	35.00	\$9,030.00
93	TOPSOIL FOR BIO-INFILTRATION SWALES, 12 INCH THICK INCL. SE	577 SY	50.00	28,850.00	20.00	\$11,540.00	39.00	\$22,503.00	20.00	\$11,540.00
94	CONSTRUCT BIO-INFILTRATION SWALE	577 SY	40.00	23,080.00	24.00	\$13,848.00	57.00	\$32,889.00	26.00	\$15,002.00
95	LANDSCAPE BOULDERS, FIVE MAN	14 EA	130.00	1,820.00	240.00	\$3,360.00	150.00	\$2,100.00	220.00	\$3,080.00
96	IRRIGATION SYSTEM	1 LS	75,000.00	75,000.00	23,000.00	\$23,000.00	30,500.00	\$30,500.00	25,000.00	\$25,000.00
97	4 IN. PVC IRRIGATION SLEEVE	57 LF	50.00	2,850.00	18.00	\$1,026.00	27.00	\$1,539.00	20.00	\$1,140.00
98	CHAIN LINK FENCE TYPE 3	182 LF	90.00	16,380.00	70.00	\$12,740.00	65.00	\$11,830.00	110.00	\$20,020.00
99	CLASSIFICATION AND PROTECTION OF SURVEY MONUMENTS	1 LS	5,000.00	5,000.00	600.00	\$600.00	4,200.00	\$4,200.00	4,000.00	\$4,000.00
100	REFERENCE AND REESTABLISH SURVEY MONUMENT	1 EA	1,500.00	1,500.00	2,250.00	\$2,250.00	700.00	\$700.00	400.00	\$400.00
101	PUMPING SYSTEM	1 LS	500,000.00	500,000.00	499,000.00	\$499,000.00	430,000.00	\$430,000.00	475,000.00	\$475,000.00
102	PUMP BARRELS (CANS) 36 IN DIAM	1 LS	200,000.00	200,000.00	105,000.00	\$105,000.00	350,000.00	\$350,000.00	335,000.00	\$335,000.00
103	PUMPS & SYSTEM STARTUP & TESTING	1 LS	50,000.00	50,000.00	10,000.00	\$10,000.00	16,000.00	\$16,000.00	15,000.00	\$15,000.00
104	BOOSTER STATION BUILDING	1 LS	810,000.00	810,000.00	945,000.00	\$945,000.00	950,000.00	\$950,000.00	740,000.00	\$740,000.00
105	GENERAL ELECTRICAL AND LIGHTING	1 LS	200,000.00	200,000.00	225,000.00	\$225,000.00	200,000.00	\$200,000.00	205,000.00	\$205,000.00
106	FLOW METER	1 LS	50,000.00	50,000.00	105,000.00	\$105,000.00	190,000.00	\$190,000.00	155,000.00	\$155,000.00
107	POWER GENERATION	1 LS	250,000.00	250,000.00	175,000.00	\$175,000.00	255,000.00	\$255,000.00	235,000.00	\$235,000.00
108	MOTOR CONTROL CENTER	1 LS	350,000.00	350,000.00	240,500.00	\$240,500.00	311,000.00	\$311,000.00	280,000.00	\$280,000.00
109	BUILDING HVAC AND CONTROLS	1 LS	175,000.00	175,000.00	105,000.00	\$105,000.00	123,000.00	\$123,000.00	128,000.00	\$128,000.00
110	PLUMBING SYSTEM	1 LS	125,000.00	125,000.00	90,000.00	\$90,000.00	240,000.00	\$240,000.00	170,000.00	\$170,000.00
111	CHLORINE ANALYZER AND PRESSURE GAUGE ASSEMBLY	1 LS	10,000.00	10,000.00	12,000.00	\$12,000.00	70,000.00	\$70,000.00	85,000.00	\$85,000.00
<b>Bid Total</b>			<b>\$5,055,158.95</b>		<b>\$5,174,158.15</b>		<b>\$5,396,990.80</b>		<b>\$5,533,298.00</b>	

**City Of Spokane**  
**Engineering Services Department**  
**\*\*\*Bid Tabulation\*\*\***

**SCHEDULE SUMMARY**

	<i>Sched 1</i>	<i>Sched 2</i>	<i>Sched 3</i>	<i>Sched 4</i>	<i>Total</i>
ENGINEER'S ESTIMATE	241,684.00	4,813,474.95	0.00	0.00	5,055,158.95
APOLLO, INC. (Submitted)	216,116.80	4,482,403.30	0.00	0.00	4,698,520.10
DW EXCAVATING INC(Submitted)	132,985.00	4,627,595.00	0.00	0.00	4,760,580.00
HALME CONSTRUCTION INC (Submitted)	150,110.50	4,620,102.50	0.00	0.00	4,770,213.00
CLEARWATER CONSTRUCTION & MANAGEMENT (Submitted)	245,909.40	4,928,248.75	0.00	0.00	5,174,158.15
BIG SKY ID CORP (Submitted)	159,308.50	5,237,682.30	0.00	0.00	5,396,990.80
S & L UNDERGROUND INC (Submitted)	142,177.50	5,391,120.50	0.00	0.00	5,533,298.00

**Low Bid Contractor:** APOLLO, INC.

	<i>Contractor's Bid</i>	<i>Engineer's Estimate</i>	<i>% Variance</i>
<i>Schedule 01</i>	216,116.80	241,684.00	10.58 % Under Estimate
<i>Schedule 02</i>	4,482,403.30	4,813,474.95	6.88 % Under Estimate
<i>Schedule 03</i>	0.00	0.00	% Under Estimate
<i>Schedule 04</i>	0.00	0.00	% Under Estimate
<b><i>Bid Totals</i></b>	4,698,520.10	5,055,158.95	7.05 % Under Estimate



< Business Lookup

**License Information:**

[New search](#) [Back to results](#)

**Entity name:** APOLLO, INC.

**Business name:** APOLLO, INC.

**Entity type:** [Profit Corporation](#)

**UBI #:** 601-490-907

**Business ID:** 001

**Location ID:** 0001

**Location:** Active

**Location address:** 1133 W COLUMBIA DR  
KENNEWICK WA 99336-3472

**Mailing address:** 1133 W COLUMBIA DR  
KENNEWICK WA 99336-3472

**Excise tax and reseller permit status:** [Click here](#)

**Secretary of State status:** [Click here](#)

< Page 1 of 2 >

**Endorsements**

Endorsements held at this location	License #	Count	Details	Status	Expiration date	First issuance date
<a href="#">Benton City General Business - Non-Resident</a>	3441			Active	Aug-31-2025	Feb-02-2022
<a href="#">College Place General Business - Non-Resident</a>				Active	Aug-31-2025	Jan-19-2021
<a href="#">East Wenatchee General Business - Non-Resident</a>				Active	Aug-31-2025	Jun-24-2022
<a href="#">Ellensburg General Business - Non-Resident</a>	10192			Active	Aug-31-2025	Nov-29-2017
<a href="#">Franklin County General Business - Non-Resident</a>	1412			Active	Aug-31-2025	Mar-30-2023
<a href="#">Kennewick Home Occupation Business</a>				Active	Aug-31-2025	Jan-19-2018
<a href="#">Mattawa General Business - Non-Resident</a>				Active	Aug-31-2025	Mar-24-2021
<a href="#">Minor Work Permit</a>				Active	Aug-31-2025	Oct-14-2011
<a href="#">Moses Lake General Business - Non-Resident</a>	BUS2016-0221			Active	Aug-31-2025	Oct-04-2016



Endorsements held at this location	License #	Count	Details	Status	Expiration date	First issuance date
Pasco General Business - Non-Resident	6704			Active	Aug-31-2025	Jan-24-2005
Prosser General Business - Non-Resident				Active	Aug-31-2025	Nov-25-2008
Pullman General Business - Non-Resident				Active	Aug-31-2025	Jul-25-2023
Quincy General Business - Non-Resident				Active	Aug-31-2025	Mar-07-2019
Richland General Business - Non-Resident	F03953			Active	Aug-31-2025	Oct-14-1998
Spokane General Business - Non-Resident				Active	Aug-31-2025	Nov-22-2013

**Governing People** May include governing people not registered with Secretary of State

Governing people	Title
HAIGHT, DAVID	
HAISCH, ANGIE	
JENNE, AMY	
RATCHFORD, BRUCE	
RATCHFORD, RYAN	

**Registered Trade Names**

Registered trade names	Status	First issued
APOLLO FEDERAL SERVICES	Active	May-10-2006
APOLLO, INC.	Active	Apr-22-1994

[View Additional Locations](#)

The Business Lookup information is updated nightly. Search date and time: 10/22/2024 2:47:22 PM

[Contact us](#)

How are we doing?  
[Take our survey!](#)

Don't see what you expected?  
[Check if your browser is supported](#)





< Business Lookup

**License Information:**

[New search](#) [Back to results](#)

**Entity name:** APOLLO, INC.

**Business name:** APOLLO, INC.

**Entity type:** [Profit Corporation](#)

**UBI #:** 601-490-907

**Business ID:** 001

**Location ID:** 0001

**Location:** Active

**Location address:** 1133 W COLUMBIA DR  
KENNEWICK WA 99336-3472

**Mailing address:** 1133 W COLUMBIA DR  
KENNEWICK WA 99336-3472

**Excise tax and reseller permit status:** [Click here](#)

**Secretary of State status:** [Click here](#)

< Page 1 of 2 >

**Endorsements**

Endorsements held at this location	License #	Count	Details	Status	Expiration date	First issuance date
<a href="#">Benton City General Business - Non-Resident</a>	3441			Active	Aug-31-2025	Feb-02-2022
<a href="#">College Place General Business - Non-Resident</a>				Active	Aug-31-2025	Jan-19-2021
<a href="#">East Wenatchee General Business - Non-Resident</a>				Active	Aug-31-2025	Jun-24-2022
<a href="#">Ellensburg General Business - Non-Resident</a>	10192			Active	Aug-31-2025	Nov-29-2017
<a href="#">Franklin County General Business - Non-Resident</a>	1412			Active	Aug-31-2025	Mar-30-2023
<a href="#">Kennewick Home Occupation Business</a>				Active	Aug-31-2025	Jan-19-2018
<a href="#">Mattawa General Business - Non-Resident</a>				Active	Aug-31-2025	Mar-24-2021
<a href="#">Minor Work Permit</a>				Active	Aug-31-2025	Oct-14-2011
<a href="#">Moses Lake General Business - Non-Resident</a>	BUS2016-0221			Active	Aug-31-2025	Oct-04-2016



Endorsements held at this location	License #	Count	Details	Status	Expiration date	First issuance date
Pasco General Business - Non-Resident	6704			Active	Aug-31-2025	Jan-24-2005
Prosser General Business - Non-Resident				Active	Aug-31-2025	Nov-25-2008
Pullman General Business - Non-Resident				Active	Aug-31-2025	Jul-25-2023
Quincy General Business - Non-Resident				Active	Aug-31-2025	Mar-07-2019
Richland General Business - Non-Resident	F03953			Active	Aug-31-2025	Oct-14-1998
Spokane General Business - Non-Resident				Active	Aug-31-2025	Nov-22-2013

**Governing People** May include governing people not registered with Secretary of State

Governing people	Title
HAIGHT, DAVID	
HAISCH, ANGIE	
JENNE, AMY	
RATCHFORD, BRUCE	
RATCHFORD, RYAN	

**Registered Trade Names**

Registered trade names	Status	First issued
APOLLO FEDERAL SERVICES	Active	May-10-2006
APOLLO, INC.	Active	Apr-22-1994

[View Additional Locations](#)

The Business Lookup information is updated nightly. Search date and time: 10/22/2024 2:47:22 PM

[Contact us](#)

How are we doing?  
[Take our survey!](#)

Don't see what you expected?  
[Check if your browser is supported](#)





This page has been left blank intentionally.



**Policy Number**  
**GLO 0110310-04**

**SCHEDULE OF FORMS AND ENDORSEMENTS**

**Zurich American Insurance Company**

**Named Insured** APOLLO SHEET METAL, INC.

**Effective Date:** 04-01-23  
12:01 A.M., Standard Time

**Agent Name** PROPEL INSURANCE

**Agent No.** 73038-000

COMMON POLICY FORMS AND ENDORSEMENTS

U-GU-1223-B CA	09-16	REVISED DEFINITION OF SPOUSE ENDORSEMENT
U-GU-D-310-A	01-93	COMMON POLICY DECLARATIONS
U-GU-619-A CW	10-02	SCHEDULE OF FORMS AND ENDORSEMENTS
U-GU-319-F	01-09	IMPORTANT NOTICE - IN WITNESS CLAUSE
U-GU-621-A CW	10-02	SCHEDULE OF NAMED INSURED(S)
U-GU-406-B	07-15	INSTALLMENT PREMIUM SCHEDULE
U-GU-1016-A CW	06-10	KNOWLEDGE BY POSITION OR DEPARTMENT
IL 01 23	11-13	WASHINGTON CHANGES - DEFENSE COSTS
IL 01 46	08-10	WASHINGTON COMMON POLICY CONDITIONS
IL 01 98	09-08	NUCLEAR ENERGY LIABILITY EXCLUSION
U-GU-298-B CW	04-94	CANCELLATION BY US
IL 00 03	09-08	CALCULATION OF PREMIUM
U-GU-1191-A CW	03-15	SANCTIONS EXCLUSION ENDORSEMENT

GENERAL LIABILITY FORMS AND ENDORSEMENTS

U-GL-2162-A CW	02-19	ADDL INSD-AUTOMATIC-OWNERS/LESSEES/CONTR
U-GL-1514-A CW	02-12	BROAD FORM PRODUCTS COVERAGE
U-GL-1517-B CW	04-13	RECORD OR DISTRB OF MATRL OR INFO EXCL
U-GL-1518-A CW	04-13	BROADENED NAMED INSURED
U-GL-1521-B CW	01-19	BLANKET NOTIFICATION TO OTH CANC/NONREN
U-GL-441-B CW	12-01	AIRCRAFT PROD., GROUNDING & TESTING EXCL
U-GL-851-B CW	06-04	EMPLOYEE BENEFITS LIAB (OCCURRENCE) COV
U-GL-915-C CW	08-04	FELLOW EMPLOYEE COVERAGE ENDORSEMENT
U-GL-917-C CW	08-04	INCIDENTAL MEDICAL MALPRACTICE COV ENDT
U-GL-923-B CW	06-04	SILICA OR SILICA MIXED DUST EXCLUSION
U-GL-925-B CW	12-01	WAIVER OF SUBROGATION (BLANKET) ENDT.
U-GL-D-851-B CW	09-04	EMPLOYEE BENEFITS LIAB (OCCURRENCE) COV
U-GL-D-1115-B CW	09-04	COMMERCIAL GL COVERAGE PART DECLARATIONS
CG 00 01	04-13	COMMERCIAL GENERAL LIABILITY COV FORM
U-GL-1060-F CW	05-22	CONTRACTORS LIABILITY ENDORSEMENT
UGL1171ACW	07-03	FUNGI OR BACTERIA EXCLUSION
U-GL-1199-A MU	04-04	ASBESTOS EXCLUSION ENDORSEMENT
U-GL-1294-A CW	10-06	LIMITED OPERATIONS-CONSOLIDATED WRAP-UP
U-GL-1327-B CW	04-13	OTH INS AMNDMT-PRIMARY & NONCONTRIBUTORY
U-GL-1347-A MU	02-08	LEAD LIABILITY EXCLUSION
U-GL-1390-A CW	04-09	METHYL TERTIARY-BUTYL ETHER EXCLUSION
U-GL-872-B CW	04-09	PREMIUM & REPORTS AGREEMENT-COMP RATED
CG 01 23	03-97	INDIANA CHANGES POLLUTION EXCLUSION
CG 01 34	08-03	MISSOURI CHANGES -POLLUTION EXCLUSION
CG 01 81	05-08	WASHINGTON CHANGES
CG 01 97	12-07	WA CHANGES-EMP RELATED PRACTICES-EXCL
CG 32 69	09-08	AK TOTAL POLLUTION EXCL W BLDG HEATING
CG 32 85	07-10	VA CHNGS - TOTAL POLLUTION W BLDG HEAT
U-GL-1059-B CW	12-14	LIMITED POLLUTION COVERAGE-WORK SITE
U-GL-2153-A CW	01-21	WHO IS AN INS AMEND-PRTRNSHPS & JV-BLNKT
U-GL-852-A CW	07-96	EMPL BENEFITS LIAB (OCCURRENCE) DED ENDT
CG 03 00	01-96	DEDUCTIBLE LIABILITY INSURANCE
CG 04 37	05-14	ELECTRONIC DATA LIABILITY ENDORSEMENT
CG 20 07	12-19	ADDL INSD - ENGRS,ARCHITECT OR SURVEYORS
CG 20 32	12-19	ADDL INSD-ENGRS ARCHTS OR SURVEYORS
CG 21 54	12-19	EXCL-DESIG OPS COVRD BY WRAP-UP INS PROG
CG 21 65	12-04	TOTAL POLLUTION EXCL-WITH EXCEPTIONS

**Policy Number**  
**GLO 0110310-04**

**SCHEDULE OF FORMS AND ENDORSEMENTS**

**Zurich American Insurance Company**

**Named Insured** APOLLO SHEET METAL, INC.

**Effective Date:** 04-01-23  
12:01 A.M., Standard Time

**Agent Name** PROPEL INSURANCE

**Agent No.** 73038-000

CG 21 73	01-15	EXCLUSION OF CERTIFIED ACTS OF TERRORISM
CG 21 86	12-04	EXCL-EXTERIOR INSULATION & FINISH SYSTEM
CG 22 79	04-13	EXCL-CONTRACTORS-PROF LIAB
CG 24 14	04-13	WAIVER OF GOVERNMENTAL IMMUNITY
CG 24 17	10-01	CONTRACTUAL LIABILITY - RAILROADS
CG 25 03	05-09	DESIGNATED CONSTRUCTION PROJECTS GENERAL
CG 25 04	05-09	DESIGNATED LOCATIONS GENERAL AGGREGATE

**Policy Number**  
**GLO 0110310-04**

**SCHEDULE OF NAMED INSURED(S)**

**ZURICH AMERICAN INSURANCE COMPANY**

**Named Insured** APOLLO SHEET METAL, INC.

**Effective Date:** 04-01-23  
12:01 A.M., Standard Time

**Agent Name** PROPEL INSURANCE

**Agent No.** 73038-000

NAMED INSURED

APOLLO SHEET METAL, INC.  
APOLLO HEATING AND AIR CONDITIONING  
APOLLO CONSTRUCTION SERVICES  
APOLLO INC. DBA APOLLO FEDERAL SERVICES  
APOLLO SOLUTIONS GROUP  
APOLLO INC DBA APOLLO CONSTRUCTION INC.  
APOLLO, INC.  
APOLLO SHEET METAL INC. DBA APOLLO HEATING & AIR CONDITIONING  
APOLLO SHEET METAL INC. DBA APOLLO CONSTRUCTION SERVICES  
APOLLO SHEET METAL INC. DBA APOLLO SOLUTIONS GROUP  
APOLLO SHEET METAL INC. DBA APOLLO MECHANICAL CONTRACTORS,  
ENVIRONMENTAL DIVISION  
APOLLO SHEET METAL INC. DBA APOLLO MECHANICAL CONTRACTORS  
APOLLO FEDERAL SERVICES  
APOLLO MECHANICAL CONTRACTORS  
APOLLO SHEET METAL DBA: APOLLO FEDERAL SERVICES  
APOLLO SHEET METAL DBA: APOLLO CONSTRUCTION INC.  
BLR HOLDINGS, INC., LLC  
APOLLO ENVIRONMENTAL  
BWR HOLDINGS LLLP



# Additional Insured – Automatic – Owners, Lessees Or Contractors

**THIS ENDORSEMENT CHANGES THE POLICY. PLEASE READ IT CAREFULLY.**

Policy No. GLO 0110310-04

Effective Date: 04/01/2023

This endorsement modifies insurance provided under the:

## **Commercial General Liability Coverage Part**

**A. Section II – Who Is An Insured** is amended to include as an additional insured any person or organization whom you are required to add as an additional insured under a written contract or written agreement executed by you, but only with respect to liability for "bodily injury", "property damage" or "personal and advertising injury" and subject to the following:

1. If such written contract or written agreement specifically requires that you provide that the person or organization be named as an additional insured under one or both of the following endorsements:

- a. The Insurance Services Office (ISO) ISO CG 20 10 (10/01 edition); or
- b. The ISO CG 20 37 (10/01 edition),

such person or organization is then an additional insured with respect to such endorsement(s), but only to the extent that "bodily injury", "property damage" or "personal and advertising injury" arises out of:

- (1) Your ongoing operations, with respect to Paragraph 1.a. above; or
- (2) "Your work", with respect to Paragraph 1.b. above,  
which is the subject of the written contract or written agreement.

However, solely with respect to this Paragraph 1., insurance afforded to such additional insured:

- (a) Only applies if the "bodily injury", "property damage" or "personal and advertising injury" offense occurs during the policy period and subsequent to your execution of the written contract or written agreement; and
- (b) Does not apply to "bodily injury" or "property damage" caused by "your work" and included within the "products-completed operations hazard" unless the written contract or written agreement specifically requires that you provide such coverage to such additional insured.

2. If such written contract or written agreement specifically requires that you provide that the person or organization be named as an additional insured under one or both of the following endorsements:

- a. The Insurance Services Office (ISO) ISO CG 20 10 (07/04 edition); or
- b. The ISO CG 20 37 (07/04 edition),

such person or organization is then an additional insured with respect to such endorsement(s), but only to the extent that "bodily injury", "property damage" or "personal and advertising injury" is caused, in whole or in part, by:

- (1) Your acts or omissions; or
- (2) The acts or omissions of those acting on your behalf,

in the performance of:

- (a) Your ongoing operations, with respect to Paragraph 2.a. above; or
- (b) "Your work" and included in the "products-completed operations hazard", with respect to Paragraph 2.b. above,

which is the subject of the written contract or written agreement.

However, solely with respect to this Paragraph 2., insurance afforded to such additional insured:

- (i) Only applies if the "bodily injury", "property damage" or "personal and advertising injury" offense occurs during the policy period and subsequent to your execution of the written contract or written agreement; and
  - (ii) Does not apply to "bodily injury" or "property damage" caused by "your work" and included within the "products-completed operations hazard" unless the written contract or written agreement specifically requires that you provide such coverage to such additional insured.
3. If neither Paragraph 1. nor Paragraph 2. above apply and such written contract or written agreement requires that you provide that the person or organization be named as an additional insured:

- a. Under the ISO CG 20 10 (04/13 edition, any subsequent edition or if no edition date is specified); or
- b. With respect to ongoing operations (if no form is specified),

such person or organization is then an additional insured only to the extent that "bodily injury", "property damage" or "personal and advertising injury" is caused, in whole or in part by:

- (1) Your acts or omissions; or
- (2) The acts or omissions of those acting on your behalf,

in the performance of your ongoing operations, which is the subject of the written contract or written agreement.

However, solely with respect to this Paragraph 3., insurance afforded to such additional insured:

- (a) Only applies to the extent permitted by law;
  - (b) Will not be broader than that which you are required by the written contract or written agreement to provide for such additional insured; and
  - (c) Only applies if the "bodily injury", "property damage" or "personal and advertising injury" offense occurs during the policy period and subsequent to your execution of the written contract or written agreement.
4. If neither Paragraph 1. nor Paragraph 2. above apply and such written contract or written agreement requires that you provide that the person or organization be named as an additional insured:

- a. Under the ISO CG 20 37 (04/13 edition, any subsequent edition or if no edition date is specified); or
- b. With respect to the "products-completed operations hazard" (if no form is specified),

such person or organization is then an additional insured only to the extent that "bodily injury" or "property damage" is caused, in whole or in part by "your work" and included in the "products-completed operations hazard", which is the subject of the written contract or written agreement.

However, solely with respect to this Paragraph 4., insurance afforded to such additional insured:

- (1) Only applies to the extent permitted by law;
- (2) Will not be broader than that which you are required by the written contract or written agreement to provide for such additional insured;
- (3) Only applies if the "bodily injury" or "property damage" occurs during the policy period and subsequent to your execution of the written contract or written agreement; and
- (4) Does not apply to "bodily injury" or "property damage" caused by "your work" and included within the "products-completed operations hazard" unless the written contract or written agreement specifically requires that you provide such coverage to such additional insured.

- B.** Solely with respect to the insurance afforded to any additional insured referenced in Section **A.** of this endorsement, the following additional exclusion applies:

This insurance does not apply to "bodily injury", "property damage" or "personal and advertising injury" arising out of the rendering of, or failure to render, any professional architectural, engineering or surveying services including:

1. The preparing, approving or failing to prepare or approve maps, shop drawings, opinions, reports, surveys, field orders, change orders or drawings and specifications; or
2. Supervisory, inspection, architectural or engineering activities.

This exclusion applies even if the claims against any insured allege negligence or other wrongdoing in the supervision, hiring, employment, training or monitoring of others by that insured, if the "occurrence" which caused the "bodily injury" or "property damage", or the offense which caused the "personal and advertising injury", involved the rendering of or the failure to render any professional architectural, engineering or surveying services.

- C.** Solely with respect to the coverage provided by this endorsement, the following is added to Paragraph **2. Duties In The Event Of Occurrence, Offense, Claim Or Suit** of Section **IV – Commercial General Liability Conditions**:

The additional insured must see to it that:

- (1) We are notified as soon as practicable of an "occurrence" or offense that may result in a claim;
- (2) We receive written notice of a claim or "suit" as soon as practicable; and
- (3) A request for defense and indemnity of the claim or "suit" will promptly be brought against any policy issued by another insurer under which the additional insured may be an insured in any capacity. This provision does not apply to insurance on which the additional insured is a Named Insured if the written contract or written agreement requires that this coverage be primary and non-contributory.

- D.** Solely with respect to the coverage provided by this endorsement:

1. The following is added to the **Other Insurance** Condition of Section **IV – Commercial General Liability Conditions**:

**Primary and Noncontributory insurance**

This insurance is primary to and will not seek contribution from any other insurance available to an additional insured provided that:

- a. The additional insured is a Named Insured under such other insurance; and
- b. You are required by written contract or written agreement that this insurance be primary and not seek contribution from any other insurance available to the additional insured.

2. The following paragraph is added to Paragraph **4.b.** of the **Other Insurance** Condition under Section **IV – Commercial General Liability Conditions**:

This insurance is excess over:

Any of the other insurance, whether primary, excess, contingent or on any other basis, available to an additional insured, in which the additional insured on our policy is also covered as an additional insured on another policy providing coverage for the same "occurrence", offense, claim or "suit". This provision does not apply to any policy in which the additional insured is a Named Insured on such other policy and where our policy is required by a written contract or written agreement to provide coverage to the additional insured on a primary and non-contributory basis.

- E.** This endorsement does not apply to an additional insured which has been added to this Coverage Part by an endorsement showing the additional insured in a Schedule of additional insureds, and which endorsement applies specifically to that identified additional insured.

- F.** Solely with respect to the insurance afforded to an additional insured under Paragraph **A.3.** or Paragraph **A.4.** of this endorsement, the following is added to Section **III – Limits Of Insurance**:

**Additional Insured – Automatic – Owners, Lessees Or Contractors Limit**

The most we will pay on behalf of the additional insured is the amount of insurance:

1. Required by the written contract or written agreement referenced in Section **A.** of this endorsement; or
2. Available under the applicable Limits of Insurance shown in the Declarations,  
whichever is less.

This endorsement shall not increase the applicable Limits of Insurance shown in the Declarations.

All other terms, conditions, provisions and exclusions of this policy remain the same.





C. With respect to the insurance afforded to these additional insureds, the following is added to **Section III – Limits Of Insurance:**

The most we will pay on behalf of the additional insured is the amount of insurance:

1. Required by the contract or agreement; or

2. Available under the applicable limits of insurance;

whichever is less.

This endorsement shall not increase the applicable limits of insurance.

# Other Insurance Amendment – Primary And Non-Contributory



Policy No.	Eff. Date of Pol.	Exp. Date of Pol.	Eff. Date of End.	Producer No.	Add'l. Prem	Return Prem.
GLO 0110310-04	04/01/2023	04/01/2024		73038000	<b>INCL</b>	

**THIS ENDORSEMENT CHANGES THE POLICY. PLEASE READ IT CAREFULLY.**

**Named Insured:**

**Address (including ZIP Code):**

This endorsement modifies insurance provided under the:

**Commercial General Liability Coverage Part**

1. The following paragraph is added to the Other Insurance Condition of Section **IV – Commercial General Liability Conditions**:

This insurance is primary insurance to and will not seek contribution from any other insurance available to an additional insured under this policy provided that:

- a. The additional insured is a Named Insured under such other insurance; and
- b. You are required by a written contract or written agreement that this insurance would be primary and would not seek contribution from any any other insurance available to the additional insured.

2. The following paragraph is added to Paragraph **4.b.** of the Other Insurance Condition of Section **IV – Commercial General Liability Conditions**:

This insurance is excess over:

Any of the other insurance, whether primary, excess, contingent or on any other basis, available to an additional insured, in which the additional insured on our policy is also covered as an additional insured on another policy providing coverage for the same "occurrence", offense, claim or "suit". This provision does not apply to any policy in which the additional insured is a Named Insured on such other policy and where our policy is required by written contract or written agreement to provide coverage to the additional insured on a primary and non-contributory basis.

All other terms and conditions of this policy remain unchanged.

# Waiver Of Subrogation (Blanket) Endorsement

Policy No.	Eff. Date of Pol.	Exp. Date of Pol.	Eff. Date of End.	Producer	Add'l Prem.	Return Prem.
GLO 0110310-04	04/01/2023	04/01/2024		73038000	\$ <b>INCL</b>	\$

**THIS ENDORSEMENT CHANGES THE POLICY. PLEASE READ IT CAREFULLY.**

This endorsement modifies insurance provided under the:

## **Commercial General Liability Coverage Part**

The following is added to the **Transfer Of Rights Of Recovery Against Others To Us Condition:**

If you are required by a written contract or agreement, which is executed before a loss, to waive your rights of recovery from others, we agree to waive our rights of recovery. This waiver of rights shall not be construed to be a waiver with respect to any other operations in which the insured has no contractual interest.



# Blanket Notification to Others of Cancellation or Non-Renewal

**THIS ENDORSEMENT CHANGES THE POLICY. PLEASE READ IT CAREFULLY.**

Policy No. GLO 0110310-04

Effective Date: 04/01/2023

This endorsement applies to insurance provided under the:

## **Commercial General Liability Coverage Part**

- A.** If we cancel or non-renew this Coverage Part by written notice to the first Named Insured, we will mail or deliver notification that such Coverage Part has been cancelled or non-renewed to each person or organization shown in a list provided to us by the first Named Insured if you are required by written contact or written agreement to provide such notification. Such list:
1. Must be provided to us prior to cancellation or non-renewal;
  2. Must contain the names and addresses of only the persons or organizations requiring notification that such Coverage Part has been cancelled or non-renewed; and
  3. Must be in an electronic format that is acceptable to us.
- B.** Our notification as described in Paragraph **A.** of this endorsement will be based on the most recent list in our records as of the date the notice of cancellation or non-renewal is mailed or delivered to the first Named Insured. We will mail or deliver such notification to each person or organization shown in the list:
1. Within 10 days of the effective date of the notice of cancellation, if we cancel for non-payment of premium; or
  2. At least 30 days prior to the effective date of:
    - a. Cancellation, if cancelled for any reason other than nonpayment of premium; or
    - b. Non-renewal, but not including conditional notice of renewal,unless a greater number of days is shown in the Schedule of this endorsement for the mailing or delivering of such notification with respect to Paragraph **B.1.** or Paragraph **B.2.** above.
- C.** Our mailing or delivery of notification described in Paragraphs **A.** and **B.** of this endorsement is intended as a courtesy only. Our failure to provide such mailing or delivery will not:
1. Extend the Coverage Part cancellation or non-renewal date;
  2. Negate the cancellation or non-renewal; or
  3. Provide any additional insurance that would not have been provided in the absence of this endorsement.

D. We are not responsible for the accuracy, integrity, timeliness and validity of information contained in the list provided to us as described in Paragraphs **A.** and **B.** of this endorsement.

<b>SCHEDULE</b>	
The total number of days for mailing or delivering with respect to Paragraph <b>B.1.</b> of this endorsement is amended to indicate the following number of days:	*
The total number of days for mailing or delivering with respect to Paragraph <b>B.2.</b> of this endorsement is amended to indicate the following number of days:	**
* If a number is not shown here, 10 days continues to apply. ** If a number is not shown here, 30 days continues to apply.	

All other terms and conditions of this policy remain unchanged.

**THIS ENDORSEMENT CHANGES THE POLICY. PLEASE READ IT CAREFULLY.**

## **DESIGNATED CONSTRUCTION PROJECT(S) GENERAL AGGREGATE LIMIT**

This endorsement modifies insurance provided under the following:

COMMERCIAL GENERAL LIABILITY COVERAGE PART

### **SCHEDULE**

**Designated Construction Project(s):**

A GENERAL AGGREGATE LIMIT APPLIES TO EACH CONSTRUCTION PROJECT WHERE THE NAMED INSURED IS PERFORMING OPERATIONS, HOWEVER, A GENERAL AGGREGATE LIMIT DOES NOT APPLY TO ANY CONSTRUCTION PROJECT WHERE THE NAMED INSURED IS PERFORMING OPERATIONS THAT ARE INSURED UNDER A WRAP UP OR ANY OTHER CONSOLIDATED OR SIMILAR INSURANCE PROGRAM.

Information required to complete this Schedule, if not shown above, will be shown in the Declarations.

- A.** For all sums which the insured becomes legally obligated to pay as damages caused by "occurrences" under Section I – Coverage **A**, and for all medical expenses caused by accidents under Section I – Coverage **C**, which can be attributed only to ongoing operations at a single designated construction project shown in the Schedule above:
  - 1.** A separate Designated Construction Project General Aggregate Limit applies to each designated construction project, and that limit is equal to the amount of the General Aggregate Limit shown in the Declarations.
  - 2.** The Designated Construction Project General Aggregate Limit is the most we will pay for the sum of all damages under Coverage **A**, except damages because of "bodily injury" or "property damage" included in the "products-completed operations hazard", and for medical expenses under Coverage **C** regardless of the number of:
    - a.** Insureds;
    - b.** Claims made or "suits" brought; or
    - c.** Persons or organizations making claims or bringing "suits".
- 3.** Any payments made under Coverage **A** for damages or under Coverage **C** for medical expenses shall reduce the Designated Construction Project General Aggregate Limit for that designated construction project. Such payments shall not reduce the General Aggregate Limit shown in the Declarations nor shall they reduce any other Designated Construction Project General Aggregate Limit for any other designated construction project shown in the Schedule above.
- 4.** The limits shown in the Declarations for Each Occurrence, Damage To Premises Rented To You and Medical Expense continue to apply. However, instead of being subject to the General Aggregate Limit shown in the Declarations, such limits will be subject to the applicable Designated Construction Project General Aggregate Limit.

- B.** For all sums which the insured becomes legally obligated to pay as damages caused by "occurrences" under Section I – Coverage **A**, and for all medical expenses caused by accidents under Section I – Coverage **C**, which cannot be attributed only to ongoing operations at a single designated construction project shown in the Schedule above:
1. Any payments made under Coverage **A** for damages or under Coverage **C** for medical expenses shall reduce the amount available under the General Aggregate Limit or the Products-completed Operations Aggregate Limit, whichever is applicable; and
  2. Such payments shall not reduce any Designated Construction Project General Aggregate Limit.
- C.** When coverage for liability arising out of the "products-completed operations hazard" is provided, any payments for damages because of "bodily injury" or "property damage" included in the "products-completed operations hazard" will reduce the Products-completed Operations Aggregate Limit, and not reduce the General Aggregate Limit nor the Designated Construction Project General Aggregate Limit.
- D.** If the applicable designated construction project has been abandoned, delayed, or abandoned and then restarted, or if the authorized contracting parties deviate from plans, blueprints, designs, specifications or timetables, the project will still be deemed to be the same construction project.
- E.** The provisions of Section III – Limits Of Insurance not otherwise modified by this endorsement shall continue to apply as stipulated.

**THIS ENDORSEMENT CHANGES THE POLICY. PLEASE READ IT CAREFULLY.**

## **DESIGNATED LOCATION(S) GENERAL AGGREGATE LIMIT**

This endorsement modifies insurance provided under the following:

COMMERCIAL GENERAL LIABILITY COVERAGE PART

SCHEDULE

<p><b>Designated Location(s):</b> EACH LOCATION, OTHER THAN CONSTRUCTION PROJECTS, OCCUPIED BY THE NAMED INSURED</p>
<p>Information required to complete this Schedule, if not shown above, will be shown in the Declarations.</p>

- A.** For all sums which the insured becomes legally obligated to pay as damages caused by "occurrences" under Section **I – Coverage A**, and for all medical expenses caused by accidents under Section **I – Coverage C**, which can be attributed only to operations at a single designated "location" shown in the Schedule above:

  - 1. A separate Designated Location General Aggregate Limit applies to each designated "location", and that limit is equal to the amount of the General Aggregate Limit shown in the Declarations.
  - 2. The Designated Location General Aggregate Limit is the most we will pay for the sum of all damages under Coverage **A**, except damages because of "bodily injury" or "property damage" included in the "products-completed operations hazard", and for medical expenses under Coverage **C** regardless of the number of:
    - a. Insureds;
    - b. Claims made or "suits" brought; or
    - c. Persons or organizations making claims or bringing "suits".
  - 3. Any payments made under Coverage **A** for damages or under Coverage **C** for medical expenses shall reduce the Designated Location General Aggregate Limit for that designated "location". Such payments shall not reduce the General Aggregate Limit shown in the Declarations nor shall they reduce any other Designated Location General Aggregate Limit for any other designated "location" shown in the Schedule above.
  - 4. The limits shown in the Declarations for Each Occurrence, Damage To Premises Rented To You and Medical Expense continue to apply. However, instead of being subject to the General Aggregate Limit shown in the Declarations, such limits will be subject to the applicable Designated Location General Aggregate Limit.



- B.** For all sums which the insured becomes legally obligated to pay as damages caused by "occurrences" under Section I – Coverage **A**, and for all medical expenses caused by accidents under Section I – Coverage **C**, which cannot be attributed only to operations at a single designated "location" shown in the Schedule above:
1. Any payments made under Coverage **A** for damages or under Coverage **C** for medical expenses shall reduce the amount available under the General Aggregate Limit or the Products-completed Operations Aggregate Limit, whichever is applicable; and
  2. Such payments shall not reduce any Designated Location General Aggregate Limit.
- C.** When coverage for liability arising out of the "products-completed operations hazard" is provided, any payments for damages because of "bodily injury" or "property damage" included in the "products-completed operations hazard" will reduce the Products-completed Operations Aggregate Limit, and not reduce the General Aggregate Limit nor the Designated Location General Aggregate Limit.
- D.** For the purposes of this endorsement, the **Definitions** Section is amended by the addition of the following definition:
- "Location" means premises involving the same or connecting lots, or premises whose connection is interrupted only by a street, roadway, waterway or right-of-way of a railroad.
- E.** The provisions of Section III – Limits Of Insurance not otherwise modified by this endorsement shall continue to apply as stipulated.

**THIS ENDORSEMENT CHANGES THE POLICY. PLEASE READ IT CAREFULLY.**

## **CONTRACTUAL LIABILITY - RAILROADS**

This endorsement modifies insurance provided under the following:

COMMERCIAL GENERAL LIABILITY COVERAGE PART

### **SCHEDULE**

<p><b>Scheduled Railroad:</b> ONLY THOSE REQUIRED BY WRITTEN CONTRACT OR AGREEMENT, EXECUTED PRIOR TO LOSS, EXCEPT WHERE PROHIBITED BY LAW</p>	<p><b>Designated Job Site:</b> ONLY THOSE REQUIRED BY WRITTEN CONTRACT OR AGREEMENT, EXECUTED PRIOR TO LOSS, EXCEPT WHERE PROHIBITED BY LAW</p>
--	---

(If no entry appears above, information required to complete this endorsement will be shown in the Declarations as applicable to this endorsement.)

With respect to operations performed for, or affecting, a Scheduled Railroad at a Designated Job Site, the definition of "insured contract" in the Definitions section is replaced by the following:

- 9. "Insured Contract" means:**
- a.** A contract for a lease of premises. However, that portion of the contract for a lease of premises that indemnifies any person or organization for damage by fire to premises while rented to you or temporarily occupied by you with permission of the owner is not an "insured contract";
  - b.** A sidetrack agreement;
  - c.** Any easement or license agreement;
  - d.** An obligation, as required by ordinance, to indemnify a municipality, except in connection with work for a municipality;
  - e.** An elevator maintenance agreement;
  - f.** That part of any other contract or agreement pertaining to your business (including an indemnification of a municipality in connection with work performed for a municipality) under which you assume the tort liability of another party to pay for "bodily injury" or "property damage" to a third person or organization. Tort liability means a liability that would be imposed by law in the absence of any contract or agreement.

Paragraph **f.** does not include that part of any contract or agreement:

- (1)** That indemnifies an architect, engineer or surveyor for injury or damage arising out of:
  - (a)** Preparing, approving or failing to prepare or approve maps, shop drawings, opinions, reports, surveys, field orders, change orders or drawings and specifications; or
  - (b)** Giving directions or instructions, or failing to give them, if that is the primary cause of the injury or damage;
- (2)** Under which the insured, if an architect, engineer or surveyor, assumes liability for an injury or damage arising out of the insured's rendering or failure to render professional services, including those listed in Paragraph **(1)** above and supervisory, inspection, architectural or engineering activities.

**Policy Number**  
**BAP 0110311-04**

**SCHEDULE OF FORMS AND ENDORSEMENTS**

**Zurich American Insurance Company**

**Named Insured** APOLLO SHEET METAL, INC.

**Effective Date:** 04-01-23  
12:01 A.M., Standard Time

**Agent Name** PROPEL INSURANCE

**Agent No.** 73038-000

COMMON POLICY FORMS AND ENDORSEMENTS

U-GU-D-310-A	01-93	COMMON POLICY DECLARATIONS
U-GU-619-A CW	10-02	SCHEDULE OF FORMS AND ENDORSEMENTS
U-GU-319-F	01-09	IMPORTANT NOTICE - IN WITNESS CLAUSE
U-GU-621-A CW	10-02	SCHEDULE OF NAMED INSURED(S)
U-GU-406-B	07-15	INSTALLMENT PREMIUM SCHEDULE
U-GU-1016-A CW	06-10	KNOWLEDGE BY POSITION OR DEPARTMENT
IL 01 23	11-13	WASHINGTON CHANGES - DEFENSE COSTS
IL 01 46	08-10	WASHINGTON COMMON POLICY CONDITIONS
IL 01 98	09-08	NUCLEAR ENERGY LIABILITY EXCLUSION
U-GU-298-B CW	04-94	CANCELLATION BY US
IL 00 03	09-08	CALCULATION OF PREMIUM
U-GU-1191-A CW	03-15	SANCTIONS EXCLUSION ENDORSEMENT

AUTOMOBILE FORMS AND ENDORSEMENTS

CA 20 54	11-20	EMPLOYEE HIRED AUTOS
U-CA-387-A	07-94	SCHEDULE OF LOSS PAYEE(S)
CA 20 01.	11-20	LESSOR-ADDL INSURED AND LOSS PAYEE
U-CA-411-E CW	02-14	PREMIUM AND REPORTS AGREEMENT-COMPOSITE
U-CA-548-A CW	10-06	SCHEDULE OF AUTO PHYSICAL DAMAGE DEDUCTI
U-CA-D-600-D	10-21	BUSINESS AUTO DECLARATIONS
CA 00 01	11-20	BUSINESS AUTO COVERAGE FORM
CA 03 01	10-13	DEDUCTIBLE LIABILITY COVERAGE
CA 03 02	10-13	DEDUCTIBLE LIABILITY COVERAGE
CA 01 13	10-13	COLORADO CHANGES
CA 01 35	02-21	WASHINGTON CHANGES
CA 01 36	10-13	NEVADA CHANGES
CA 01 49	10-13	OREGON CHANGES
U-CA-832-A CW	01-13	BLANKET NOTIFCATION TO OTH CANC/NONREN
CA 21 05	01-16	OREGON UM COVERAGE - BODILY INJURY
CA 22 36	11-16	OR PERSONAL INJURY PROTECTION
CA 01 72	10-13	MT CHANGES - AUTO MED PAY COVERAGE
CA 04 40	10-13	CO - AUTO MEDICAL PAYMENTS COVERAGE
CA 23 45	11-20	PUBLIC LIVERY & ON-DEMAND DELIVRY EXCL
CA 31 17	10-13	OH UM COVERAGE- PROPERTY DAMAGE
CA 99 48	10-13	POLLUTION LIAB BROAD COV FOR COV AUTO
U-CA-424-H CW	10-21	COVERAGE EXTENSION ENDORSEMENT
U-CA-816-B CW	10-21	AMENDMENT OF DECLARATIONS - ITEM 4
U-CA-825-B CW	02-14	WHO IS AN INSURED AMENDMENT - BROAD FORM
CA 99 03	10-13	AUTO MEDICAL PAYMENTS COVERAGE
CA 01 21	10-13	LIMITED MEXICO COVERAGE
CA 20 48	10-13	DESIGNATED INSURED
CA 99 23	10-13	RENTAL REIMBURSEMENT COVERAGE
CA 99 44	10-13	LOSS PAYABLE CLAUSE
CA 99 60	10-13	AUDIO VISUAL & DATA ELEC EQUIP COV
CA 99 33	10-13	EMPLOYEES AS INSUREDS

**Policy Number**  
**BAP 0110311-04**

**SCHEDULE OF NAMED INSURED(S)**

**ZURICH AMERICAN INSURANCE COMPANY**

**Named Insured** APOLLO SHEET METAL, INC.

**Effective Date:** 04-01-23  
12:01 A.M., Standard Time

**Agent Name** PROPEL INSURANCE

**Agent No.** 73038-000

NAMED INSURED

APOLLO SHEET METAL, INC.  
APOLLO CONSTRUCTION SERVICES

APOLLO ENVIRONMENTAL

APOLLO FEDERAL SERVICES

APOLLO HEATING AND AIR CONDITIONING

APOLLO INC DBA APOLLO CONSTRUCTION INC.

APOLLO INC DBA APOLLO FEDERAL SERVICES

APOLLO MECHANICAL CONTRACTORS

APOLLO SHEET METAL DBA: APOLLO CONSTRUCTION INC.

APOLLO SHEET METAL DBA: APOLLO FEDERAL SERVICES

APOLLO SHEET METAL INC. DBA APOLLO CONSTRUCTION SERVICES

APOLLO SHEET METAL INC. DBA APOLLO HEATING & AIR CONDITIONING

APOLLO SHEET METAL INC. DBA APOLLO MECHANICAL CONTRACTORS

APOLLO SHEET METAL INC. DBA APOLLO MECHANICAL CONTRACTORS,  
ENVIRONMENTAL DIVISION

APOLLO SHEET METAL INC. DBA APOLLO SOLUTIONS GROUP

APOLLO SOLUTIONS GROUP

APOLLO, INC.

BLR HOLDINGS, INC., LLC

BWR HOLDINGS LLLP

**THIS ENDORSEMENT CHANGES THE POLICY. PLEASE READ IT CAREFULLY.**

## **DESIGNATED INSURED FOR COVERED AUTOS LIABILITY COVERAGE**

This endorsement modifies insurance provided under the following:

- AUTO DEALERS COVERAGE FORM
- BUSINESS AUTO COVERAGE FORM
- MOTOR CARRIER COVERAGE FORM

With respect to coverage provided by this endorsement, the provisions of the Coverage Form apply unless modified by this endorsement.

This endorsement identifies person(s) or organization(s) who are "insureds" for Covered Autos Liability Coverage under the Who Is An Insured provision of the Coverage Form. This endorsement does not alter coverage provided in the Coverage Form.

This endorsement changes the policy effective on the inception date of the policy unless another date is indicated below.

<p><b>Named Insured:</b> APOLLO SHEET METAL, INC.</p> <p><b>Endorsement Effective Date:</b></p>
---

### **SCHEDULE**

<p><b>Name Of Person(s) Or Organization(s):</b></p> <p>ANY PERSON OR ORGANIZATION TO WHOM OR WHICH YOU ARE REQUIRED TO PROVIDE ADDITIONAL INSURED STATUS OR ADDITIONAL INSURED STATUS ON A PRIMARY, NON-CONTRIBUTORY BASIS, IN A WRITTEN CONTRACT OR WRITTEN AGREEMENT EXECUTED PRIOR TO LOSS, EXCEPT WHERE SUCH CONTRACT OR AGREEMENT IS PROHIBITED BY LAW</p>
---

Information required to complete this Schedule, if not shown above, will be shown in the Declarations.

Each person or organization shown in the Schedule is an “insured” for Covered Autos Liability Coverage, but only to the extent that person or organization qualifies as an “insured” under the Who Is An Insured provision contained in Paragraph **A.1.** of Section **II** – Covered Autos Liability Coverage in the Business Auto and Motor Carrier Coverage Forms and Paragraph **D.2.** of Section **I** – Covered Autos Coverages of the Auto Dealers Coverage Form.



# Coverage Extension Endorsement

**THIS ENDORSEMENT CHANGES THE POLICY. PLEASE READ IT CAREFULLY.**

Policy No. BAP 0110311-04

Effective Date: 04/01/2023

This endorsement modifies insurance provided under the:

**Business Auto Coverage Form  
Motor Carrier Coverage Form**

## A. Amended Who Is An Insured

1. The following is added to the **Who Is An Insured** Provision in **Section II – Covered Autos Liability Coverage**:

The following are also "insureds":

- a. Any "employee" of yours is an "insured" while using a covered "auto" you don't own, hire or borrow for acts performed within the scope of employment by you. Any "employee" of yours is also an "insured" while operating an "auto" hired or rented under a contract or agreement in an "employee's" name, with your permission, while performing duties related to the conduct of your business.
- b. Anyone volunteering services to you is an "insured" while using a covered "auto" you don't own, hire or borrow to transport your clients or other persons in activities necessary to your business.
- c. Anyone else who furnishes an "auto" referenced in Paragraphs **A.1.a.** and **A.1.b.** in this endorsement.
- d. Where and to the extent permitted by law, any person(s) or organization(s) where required by written contract or written agreement with you executed prior to any "accident", including those person(s) or organization(s) directing your work pursuant to such written contract or written agreement with you, provided the "accident" arises out of operations governed by such contract or agreement and only up to the limits required in the written contract or written agreement, or the Limits of Insurance shown in the Declarations, whichever is less.

2. The following is added to the **Other Insurance** Condition in the Business Auto Coverage Form and the **Other Insurance – Primary and Excess Insurance Provisions Condition** in the Motor Carrier Coverage Form:

Coverage for any person(s) or organization(s), where required by written contract or written agreement with you executed prior to any "accident", will apply on a primary and non-contributory basis and any insurance maintained by the additional "insured" will apply on an excess basis. However, in no event will this coverage extend beyond the terms and conditions of the Coverage Form.

## B. Amendment – Supplementary Payments

Paragraphs **a.(2)** and **a.(4)** of the **Coverage Extensions** Provision in **Section II – Covered Autos Liability Coverage** are replaced by the following:

- (2) Up to \$5,000 for the cost of bail bonds (including bonds for related traffic law violations) required because of an "accident" we cover. We do not have to furnish these bonds.
- (4) All reasonable expenses incurred by the "insured" at our request, including actual loss of earnings up to \$500 a day because of time off from work.

## C. Fellow Employee Coverage

The **Fellow Employee** Exclusion contained in **Section II – Covered Autos Liability Coverage** does not apply.

#### **D. Driver Safety Program Liability and Physical Damage Coverage**

1. The following is added to the **Racing** Exclusion in **Section II – Covered Autos Liability Coverage**:

This exclusion does not apply to covered "autos" participating in a driver safety program event, such as, but not limited to, auto or truck rodeos and other auto or truck agility demonstrations.

2. The following is added to Paragraph **2.** in **B. Exclusions** of **Section III – Physical Damage Coverage** of the Business Auto Coverage Form and Paragraph **2.b.** in **B. Exclusions** of **Section IV – Physical Damage Coverage** of the Motor Carrier Coverage Form:

This exclusion does not apply to covered "autos" participating in a driver safety program event, such as, but not limited to, auto or truck rodeos and other auto or truck agility demonstrations.

#### **E. Lease or Loan Gap Coverage**

The following is added to the **Coverage** Provision of the **Physical Damage Coverage** Section:

##### **Lease Or Loan Gap Coverage**

In the event of a total "loss" to a covered "auto", we will pay any unpaid amount due on the lease or loan for a covered "auto", less:

- a. Any amount paid under the **Physical Damage Coverage** Section of the Coverage Form; and
- b. Any:
  - (1) Overdue lease or loan payments at the time of the "loss";
  - (2) Financial penalties imposed under a lease for excessive use, abnormal wear and tear or high mileage;
  - (3) Security deposits not returned by the lessor;
  - (4) Costs for extended warranties, credit life insurance, health, accident or disability insurance purchased with the loan or lease; and
  - (5) Carry-over balances from previous leases or loans.

#### **F. Towing and Labor**

Paragraph **A.2.** of the **Physical Damage Coverage** Section is replaced by the following:

We will pay up to \$75 for towing and labor costs incurred each time a covered "auto" that is a "private passenger type", light truck or medium truck is disabled. However, the labor must be performed at the place of disablement.

As used in this provision, "private passenger type" means a private passenger or station wagon type "auto" and includes an "auto" of the pickup or van type if not used for business purposes.

#### **G. Extended Glass Coverage**

The following is added to Paragraph **A.3.a.** of the **Physical Damage Coverage** Section:

If glass must be replaced, the deductible shown in the Declarations will apply. However, if glass can be repaired and is actually repaired rather than replaced, the deductible will be waived. You have the option of having the glass repaired rather than replaced.

#### **H. Hired Auto Physical Damage – Increased Loss of Use Expenses**

The **Coverage Extension** for **Loss Of Use Expenses** in the **Physical Damage Coverage** Section is replaced by the following:

##### **Loss Of Use Expenses**

For Hired Auto Physical Damage, we will pay expenses for which an "insured" becomes legally responsible to pay for loss of use of a vehicle rented or hired without a driver under a written rental contract or written rental agreement. We will pay for loss of use expenses if caused by:

- (1) Other than collision only if the Declarations indicate that Comprehensive Coverage is provided for any covered "auto";



- (2) Specified Causes Of Loss only if the Declarations indicate that Specified Causes Of Loss Coverage is provided for any covered "auto"; or
  - (3) Collision only if the Declarations indicate that Collision Coverage is provided for any covered "auto".
- However, the most we will pay for any expenses for loss of use is \$100 per day, to a maximum of \$3000.

#### I. Personal Effects Coverage

The following is added to the **Coverage** Provision of the **Physical Damage Coverage** Section:

##### Personal Effects Coverage

- a. We will pay up to \$750 for "loss" to personal effects which are:
  - (1) Personal property owned by an "insured"; and
  - (2) In or on a covered "auto".
- b. Subject to Paragraph a. above, the amount to be paid for "loss" to personal effects will be based on the lesser of:
  - (1) The reasonable cost to replace; or
  - (2) The actual cash value.
- c. The coverage provided in Paragraphs a. and b. above, only applies in the event of a total theft of a covered "auto". No deductible applies to this coverage. However, we will not pay for "loss" to personal effects of any of the following:
  - (1) Accounts, bills, currency, deeds, evidence of debt, money, notes, securities, or commercial paper or other documents of value.
  - (2) Bullion, gold, silver, platinum, or other precious alloys or metals; furs or fur garments; jewelry, watches, precious or semi-precious stones.
  - (3) Paintings, statuary and other works of art.
  - (4) Contraband or property in the course of illegal transportation or trade.
  - (5) Tapes, records, discs or other similar devices used with audio, visual or data electronic equipment.

Any coverage provided by this Provision is excess over any other insurance coverage available for the same "loss".

#### J. Tapes, Records and Discs Coverage

- 1. The Exclusion in Paragraph B.4.a. of **Section III – Physical Damage Coverage** in the Business Auto Coverage Form and the Exclusion in Paragraph B.2.c. of **Section IV – Physical Damage Coverage** in the Motor Carrier Coverage Form does not apply.
- 2. The following is added to Paragraph 1.a. **Comprehensive Coverage** under the **Coverage** Provision of the **Physical Damage Coverage** Section:

We will pay for "loss" to tapes, records, discs or other similar devices used with audio, visual or data electronic equipment. We will pay only if the tapes, records, discs or other similar audio, visual or data electronic devices:

- (a) Are the property of an "insured"; and
- (b) Are in a covered "auto" at the time of "loss".

The most we will pay for such "loss" to tapes, records, discs or other similar devices is \$500. The **Physical Damage Coverage Deductible** Provision does not apply to such "loss".

#### K. Airbag Coverage

The Exclusion in Paragraph B.3.a. of **Section III – Physical Damage Coverage** in the Business Auto Coverage Form and the Exclusion in Paragraph B.4.a. of **Section IV – Physical Damage Coverage** in the Motor Carrier Coverage Form does not apply to the accidental discharge of an airbag.

#### L. Two or More Deductibles

The following is added to the **Deductible** Provision of the **Physical Damage Coverage** Section:

If an accident is covered both by this policy or Coverage Form and by another policy or Coverage Form issued to you by us, the following applies for each covered "auto" on a per vehicle basis:

1. If the deductible on this policy or Coverage Form is the smaller (or smallest) deductible, it will be waived; or
2. If the deductible on this policy or Coverage Form is not the smaller (or smallest) deductible, it will be reduced by the amount of the smaller (or smallest) deductible.

#### **M. Temporary Substitute Autos – Physical Damage**

1. The following is added to **Section I – Covered Autos**:

##### **Temporary Substitute Autos – Physical Damage**

If Physical Damage Coverage is provided by this Coverage Form on your owned covered "autos", the following types of vehicles are also covered "autos" for Physical Damage Coverage:

Any "auto" you do not own when used with the permission of its owner as a temporary substitute for a covered "auto" you do own but is out of service because of its:

1. Breakdown;
  2. Repair;
  3. Servicing;
  4. "Loss"; or
  5. Destruction.
2. The following is added to the Paragraph **A. Coverage** Provision of the **Physical Damage Coverage** Section:

##### **Temporary Substitute Autos – Physical Damage**

We will pay the owner for "loss" to the temporary substitute "auto" unless the "loss" results from fraudulent acts or omissions on your part. If we make any payment to the owner, we will obtain the owner's rights against any other party.

The deductible for the temporary substitute "auto" will be the same as the deductible for the covered "auto" it replaces.

#### **N. Amended Duties In The Event Of Accident, Claim, Suit Or Loss**

Paragraph **a.** of the **Duties In The Event Of Accident, Claim, Suit Or Loss** Condition is replaced by the following:

- a.** In the event of "accident", claim, "suit" or "loss", you must give us or our authorized representative prompt notice of the "accident", claim, "suit" or "loss". However, these duties only apply when the "accident", claim, "suit" or "loss" is known to you (if you are an individual), a partner (if you are a partnership), a member (if you are a limited liability company) or an executive officer or insurance manager (if you are a corporation). The failure of any agent, servant or employee of the "insured" to notify us of any "accident", claim, "suit" or "loss" shall not invalidate the insurance afforded by this policy.

Include, as soon as practicable:

- (1) How, when and where the "accident" or "loss" occurred and if a claim is made or "suit" is brought, written notice of the claim or "suit" including, but not limited to, the date and details of such claim or "suit";
- (2) The "insured's" name and address; and
- (3) To the extent possible, the names and addresses of any injured persons and witnesses.

If you report an "accident", claim, "suit" or "loss" to another insurer when you should have reported to us, your failure to report to us will not be seen as a violation of these amended duties provided you give us notice as soon as practicable after the fact of the delay becomes known to you.

#### **O. Waiver of Transfer Of Rights Of Recovery Against Others To Us**

The following is added to the **Transfer Of Rights Of Recovery Against Others To Us** Condition:

This Condition does not apply to the extent required of you by a written contract, executed prior to any "accident" or "loss", provided that the "accident" or "loss" arises out of operations contemplated by such contract. This waiver only applies to the person or organization designated in the contract.

**P. Employee Hired Autos – Physical Damage**

Paragraph **b.** of the **Other Insurance** Condition in the Business Auto Coverage Form and Paragraph **f.** of the **Other Insurance – Primary and Excess Insurance Provisions** Condition in the Motor Carrier Coverage Form are replaced by the following:

For Hired Auto Physical Damage Coverage, the following are deemed to be covered "autos" you own:

- (1) Any covered "auto" you lease, hire, rent or borrow; and
- (2) Any covered "auto" hired or rented under a written contract or written agreement entered into by an "employee" or elected or appointed official with your permission while being operated within the course and scope of that "employee's" employment by you or that elected or appointed official's duties as respect their obligations to you.

However, any "auto" that is leased, hired, rented or borrowed with a driver is not a covered "auto".

**Q. Unintentional Failure to Disclose Hazards**

The following is added to the **Concealment, Misrepresentation Or Fraud** Condition:

However, we will not deny coverage under this Coverage Form if you unintentionally:

- (1) Fail to disclose any hazards existing at the inception date of this Coverage Form; or
- (2) Make an error, omission, improper description of "autos" or other misstatement of information.

You must notify us as soon as possible after the discovery of any hazards or any other information that was not provided to us prior to the acceptance of this policy.

**R. Hired Auto – World Wide Coverage**

Paragraph **7.b.(5)** of the **Policy Period, Coverage Territory** Condition is replaced by the following:

- (5) Anywhere else in the world if a covered "auto" is leased, hired, rented or borrowed for a period of 60 days or less,

**S. Bodily Injury Redefined**

The definition of "bodily injury" in the **Definitions** Section is replaced by the following:

"Bodily injury" means bodily injury, sickness or disease, sustained by a person including death or mental anguish, resulting from any of these at any time. Mental anguish means any type of mental or emotional illness or disease.

**T. Expected Or Intended Injury**

The **Expected Or Intended Injury** Exclusion in Paragraph **B. Exclusions** under **Section II – Covered Auto Liability Coverage** is replaced by the following:

**Expected Or Intended Injury**

"Bodily injury" or "property damage" expected or intended from the standpoint of the "insured". This exclusion does not apply to "bodily injury" or "property damage" resulting from the use of reasonable force to protect persons or property.

**U. Physical Damage – Additional Temporary Transportation Expense Coverage**

Paragraph **A.4.a.** of **Section III – Physical Damage Coverage** is replaced by the following:

**4. Coverage Extensions**

**a. Transportation Expenses**

We will pay up to \$50 per day to a maximum of \$1,000 for temporary transportation expense incurred by you because of the total theft of a covered "auto" of the private passenger type. We will pay only for those covered "autos" for which you carry either Comprehensive or Specified Causes of Loss Coverage. We will pay for temporary transportation expenses incurred during the period beginning 48 hours after the theft and ending, regardless of the policy's expiration, when the covered "auto" is returned to use or we pay for its "loss".

#### **V. Replacement of a Private Passenger Auto with a Hybrid or Alternative Fuel Source Auto**

The following is added to Paragraph **A. Coverage** of the **Physical Damage Coverage** Section:

In the event of a total "loss" to a covered "auto" of the private passenger type that is replaced with a hybrid "auto" or "auto" powered by an alternative fuel source of the private passenger type, we will pay an additional 10% of the cost of the replacement "auto", excluding tax, title, license, other fees and any aftermarket vehicle upgrades, up to a maximum of \$2500. The covered "auto" must be replaced by a hybrid "auto" or an "auto" powered by an alternative fuel source within 60 calendar days of the payment of the "loss" and evidenced by a bill of sale or new vehicle lease agreement.

To qualify as a hybrid "auto", the "auto" must be powered by a conventional gasoline engine and another source of propulsion power. The other source of propulsion power must be electric, hydrogen, propane, solar or natural gas, either compressed or liquefied. To qualify as an "auto" powered by an alternative fuel source, the "auto" must be powered by a source of propulsion power other than a conventional gasoline engine. An "auto" solely propelled by biofuel, gasoline or diesel fuel or any blend thereof is not an "auto" powered by an alternative fuel source.

#### **W. Return of Stolen Automobile**

The following is added to the **Coverage Extension** Provision of the **Physical Damage Coverage** Section:

If a covered "auto" is stolen and recovered, we will pay the cost of transport to return the "auto" to you. We will pay only for those covered "autos" for which you carry either Comprehensive or Specified Causes of Loss Coverage.

All other terms, conditions, provisions and exclusions of this policy remain the same.



# Blanket Notification to Others of Cancellation or Non-Renewal

Policy No.	Eff. Date of Pol.	Exp. Date of Pol.	Eff. Date of End.	Producer No.	Add'l. Prem	Return Prem.
BAP 0110311-04	04/01/2023	04/01/2024		73038000	<b>INCL</b>	

**THIS ENDORSEMENT CHANGES THE POLICY. PLEASE READ IT CAREFULLY.**

This endorsement modifies insurance provided under the:

**Commercial Automobile Coverage Part**

- A.** If we cancel or non-renew this Coverage Part by written notice to the first Named Insured, we will mail or deliver notification that such Coverage Part has been cancelled or non-renewed to each person or organization shown in a list provided to us by the first Named Insured if you are required by written contact or written agreement to provide such notification. However, such notification will not be mailed or delivered if a conditional notice of renewal has been sent to the first Named Insured. Such list:
  - 1. Must be provided to us prior to cancellation or non-renewal;
  - 2. Must contain the names and addresses of only the persons or organizations requiring notification that such Coverage Part has been cancelled or non-renewed; and
  - 3. Must be in an electronic format that is acceptable to us.
- B.** Our notification as described in Paragraph **A.** of this endorsement will be based on the most recent list in our records as of the date the notice of cancellation or non-renewal is mailed or delivered to the first Named Insured. We will mail or deliver such notification to each person or organization shown in the list:
  - 1. Within seven days of the effective date of the notice of cancellation, if we cancel for non-payment of premium; or
  - 2. At least 30 days prior to the effective date of:
    - a. Cancellation, if cancelled for any reason other than nonpayment of premium; or
    - b. Non-renewal, but not including conditional notice of renewal.
- C.** Our mailing or delivery of notification described in Paragraphs **A.** and **B.** of this endorsement is intended as a courtesy only. Our failure to provide such mailing or delivery will not:
  - 1. Extend the Coverage Part cancellation or non-renewal date;
  - 2. Negate the cancellation or non-renewal; or
  - 3. Provide any additional insurance that would not have been provided in the absence of this endorsement.
- D.** We are not responsible for the accuracy, integrity, timeliness and validity of information contained in the list provided to us as described in Paragraphs **A.** and **B.** of this endorsement.

All other terms and conditions of this policy remain unchanged.

Form Number & Edition Date	Form Name
FORMS AND ENDORSEMENTS	
U-WC-3068-B CA	04-18 CA NOTICE - WAIVER OF WC COVERAGE
U-WC-D-314-A	07-94 WORKERS COMPENSATION INFORMATION PAGE
WC 99 03 02	05-04 FOREIGN VOLUNTARY COMPENSATION
WC 99 03 02 CA	05-19 FOREIGN VOLUNTARY COMPENSATION
U-GU-1223-B CA	09-16 REVISED DEFINITION OF SPOUSE ENDORSEMENT
U-WC-315-A	07-94 CLASSIFICATION SCHEDULE
U-WC-D-322-A	07-94 SUPPLEMENTAL INFORMATION PAGE
WC 00 00 00 C	01-15 INSURANCE POLICY
WC 00 01 06 A	04-92 LONGSHORE/HARBOR WORKERS' COMP COVG ENDT
WC 00 03 01 A	02-89 ALTERNATE EMPLOYER ENDORSEMENT
WC 00 03 03 C	10-04 EMPLOYERS LIABILITY COV ENDT
WC 00 04 04	04-84 PENDING RATE CHANGE ENDORSEMENT
WC 00 04 14	07-90 NOTIFICATION OF CHANGE IN OWNERSHIP ENDT
WC 00 04 14 A	01-19 90DAY REPORT-NOTIF CHANGE IN OWNERSHIP
WC 00 04 21 C	09-08 CATASTROPHE (OTHER THAN CERT ACTS) ENDT
WC 00 04 21 D	01-15 CATASTROPHE (OTHER THAN CERT ACTS) ENDT
WC 00 04 21 F	08-22 CATASTROPHE (OTHER THAN CERT ACTS) ENDT
WC 00 04 22 B	01-15 TERRORISM RISK PGM REAUTH ACT DISCL ENDT
WC 00 04 22 C	01-21 TERRORISM RISK PGM REAUTH ACT DISCL ENDT
WC 00 04 24	01-17 AUDIT NONCOMPLIANCE CHARGE ENDT
WC 99 00 02	10-99 SCHEDULE OF INSUREDS AND LOCATIONS
WC 00 03 13	04-84 WAIVER OF RIGHTS TO RECOVER FROM OTHERS
WC 99 06 43	01-13 BLANKET NOTIFICATION TO OTH CANCEL/NONREN
U-WC-320-A	07-94 SCHEDULE OF FORMS AND ENDORSEMENTS
U-GU-406-B	07-15 INSTALLMENT PREMIUM SCHEDULE
WC 00 03 11 A	08-91 VOLUNTARY COMPENSATION AND EMPLOYERS COV
WC 00 03 02	04-84 DESIGNATED WORKPLACES EXCLUSION ENDT
WC 00 04 06 A	07-95 PREMIUM DISCOUNT ENDT
WC 02 06 01 C	09-21 AZ CANCELLATION AND NONRENEWAL ENDT
WC 02 06 03 A	12-22 AZ AMENDATORY ENDT
WC 04 03 01 D	02-18 CA POLICY AMENDATORY ENDORSEMENT
WC 04 03 60 B	01-15 CA EMPLOYERS' LIAB COV AMENDATORY ENDT
WC 04 04 21	01-08 CA OPTIONAL PREMIUM INCREASE ENDORSEMENT
WC 04 06 01 B	01-22 CA CANCELATION ENDT
WC 04 06 04 A	01-23 CA COVID19 REPORTING ENDT
WC 05 04 02	11-90 CO CLASSIFICATION ENDORSEMENT
WC 25 03 05	07-02 MT INTENTIONAL INJURY EXCLUSION ENDT
WC 25 06 01 B	04-16 MT AMENDATORY ENDORSEMENT
WC 25 06 02	01-94 MT SAFETY ENDORSEMENT
WC 27 06 01 C	10-08 NV CANCELLATION AND NONRENEWAL ENDT
WC 30 06 01 A	03-15 NM CANCELATION AND NONRENEWAL ENDT
WC 36 06 01 E	01-08 OREGON CANCELLATION ENDORSEMENT
WC 36 06 04	01-17 OREGON AMENDATORY ENDORSEMENT
WC 43 06 02	07-02 UT CANCELLATION ENDORSEMENT
WC 49 03 01	07-92 WY AMENDATORY ENDORSEMENT
WC990001A	04-10 WC AND EMPLOYERS LIABILITY IN WITNESS
WC 99 06 42 A	03-15 WASHINGTON CHANGES
WC 99 06 83	01-15 NORTH DAKOTA CHANGES
WC 04 04 22	01-12 CA SHORT-RATE CANCELATION ENDORSEMENT
WC 36 06 03	01-11 OR EMP PAID MED CLAIMS ENDT
WC 25 04 01 A	01-17 MT AUDIT NONCOMPLIANCE CHARGE ENDT
U-WC-402-A	05-03 MODIFICATION OF TIME FOR NOTICE OF CANCL
U-WC-402-B	09-03 MODIFICATION OF TIME FOR NOTICE OF CNCL
U-WC-402-B (NV)	09-03 MODIFICATION OF TIME FOR NOTICE OF CNCL
WC 00 04 19	01-01 PREMIUM DUE DATE ENDORSEMENT
WC 00 04 19 A	08-22 PREMIUM AMENDATORY ENDORSEMENT
WC 36 03 06	01-02 OR LIMITS OF LIABILITY ENDORSMENT
U-GU-632-E CW	01-20 DISCLOSURE NOTICE OF TERRORISM COVERAGE

**WAIVER OF OUR RIGHT TO RECOVER FROM OTHERS ENDORSEMENT**

We have the right to recover our payments from anyone liable for an injury covered by this policy. We will not enforce our right against the person or organization named in the Schedule. (This agreement applies only to the extent that you perform work under a written contract that requires you to obtain this agreement from us.)

This agreement shall not operate directly or indirectly to benefit anyone not named in the Schedule.

## Schedule

ALL PERSONS AND/OR ORGANIZATIONS THAT ARE REQUIRED BY WRITTEN CONTRACT OR AGREEMENT WITH THE INSURED, EXECUTED PRIOR TO THE ACCIDENT OR LOSS, THAT WAIVER OF SUBROGATION BE PROVIDED UNDER THIS POLICY FOR WORK PERFORMED BY YOU FOR THAT PERSON AND/OR ORGANIZATION

This endorsement changes the policy to which it is attached and is effective on the date issued unless otherwise stated.  
(The information below is required only when this endorsement is issued subsequent to preparation of the policy.)

Endorsement Effective **04-01-23** Policy No. **WC 0110309-04**

Insured **APOLLO SHEET METAL, INC.**

Endorsement No.

Premium \$ **INCL.**

Insurance Company **ZURICH AMERICAN INSURANCE COMPANY**

Countersigned By \_\_\_\_\_

---

**BLANKET NOTIFICATION TO OTHERS OF CANCELLATION OR NONRENEWAL ENDORSEMENT**

This endorsement adds the following to Part Six of the policy.

**PART SIX  
CONDITIONS**

**Blanket Notification to Others of Cancellation or Nonrenewal**

1. If we cancel or non-renew this policy by written notice to you, we will mail or deliver notification that such policy has been cancelled or non-renewed to each person or organization shown in a list provided to us by you if you are required by written contract or written agreement to provide such notification. However, such notification will not be mailed or delivered if a conditional notice of renewal has been sent to you. Such list:
  - a. Must be provided to us prior to cancellation or non-renewal;
  - b. Must contain the names and addresses of only the persons or organizations requiring notification that such policy has been cancelled or non-renewed; and
  - c. Must be in an electronic format that is acceptable to us.
2. Our notification as described in Paragraph 1. above will be based on the most recent list in our records as of the date the notice of cancellation or non-renewal is mailed or delivered to you. We will mail or deliver such notification to each person or organization shown in the list:
  - a. Within seven days of the effective date of the notice of cancellation, if we cancel for non-payment of premium; or
  - b. At least 30 days prior to the effective date of:
    - (1) Cancellation, if cancelled for any reason other than nonpayment of premium; or
    - (2) Non-renewal, but not including conditional notice of renewal.
3. Our mailing or delivery of notification described in Paragraphs 1. and 2. above is intended as a courtesy only. Our failure to provide such mailing or delivery will not:
  - a. Extend the policy cancellation or non-renewal date;
  - b. Negate the cancellation or non-renewal; or
  - c. Provide any additional insurance that would not have been provided in the absence of this endorsement.
4. We are not responsible for the accuracy, integrity, timeliness and validity of information contained in the list provided to us as described in Paragraphs 1. and 2. above.

All other terms and conditions of this policy remain unchanged.

This endorsement changes the policy to which it is attached and is effective on the date issued unless otherwise stated.

**(The information below is required only when this endorsement is issued subsequent to preparation of the policy.)**

Endorsement Effective  
Insured

Policy No.

Endorsement No.  
Premium \$

Insurance Company



## SCHEDULE OF UNDERLYING INSURANCE

Forms a part of Policy No. **029316160**  
Issued to: **APOLLO SHEET METAL, INC.**

By: **LEXINGTON INSURANCE COMPANY**

---

### Employers' Liability

Company: **Zurich American Insurance Company**

Policy Number: **WC011030904**

Policy Period: From: **04/01/23**                      **04/01/24**

Minimum Applicable Limits:

Bodily Injury by accident:	\$ 1,000,000	Each Accident
Bodily Injury by disease	\$ 1,000,000	Each Employee
Bodily Injury by disease	\$ 1,000,000	Policy Limit

---

### Commercial Auto Liability

X Occurrence    Claims Made

Company: **Zurich American Insurance Company**

Policy Number: **BAP011031104**

Policy Period: From: **04/01/23**      To: **04/01/24**

Minimum Applicable Limits:

Each Occurrence:	\$ 2,000,000	CSL
------------------	--------------	-----

---

### Commercial General Liability

X Occurrence    Claims Made

Company: **Zurich American Insurance Company**

Policy Number: **GL0011031004**

Policy Period: From: **04/01/23**      To: **04/01/24**

Minimum Applicable Limits:

Each Occurrence:	\$ 1,000,000		
Personal and Advertising Injury:	\$ 1,000,000		
General Aggregate:	\$ 2,000,000	Per Project	Per Location
Products/Completed Operations Aggregate:	\$2,000,000		
Defense Expenses: (Limits of Liability)	Inside	X	Outside

---

### Other Coverage: Employee Benefit Liability

Occurrence    Claims Made

Company: **Zurich American Insurance Company**

Policy Number: **GL0011031004**

Policy Period: From: **04/01/23**      To: **04/01/24**

Minimum Applicable Limits:

Each Occurrence:	\$ 1,000,000		
Other Aggregate	\$ 1,000,000		
Defense Expenses: (Limits of Liability)	Inside	X	Outside

**ENDORSEMENT**

This endorsement, effective 12:01 AM 04/01/2023

Forms a part of policy no.: 029316160

Issued to: APOLLO SHEET METAL, INC.

By: LEXINGTON INSURANCE COMPANY

**PRIMARY AND NON-CONTRIBUTORY IF REQUIRED BY WRITTEN CONTRACT  
ENDORSEMENT**

This endorsement modifies insurance provided under the following:

**COMMERCIAL UMBRELLA LIABILITY POLICY**

Provided that, all of the following conditions are met:

1. The written contract or written agreement requiring that the additional insured be added to this insurance also requires that this insurance be primary and non-contributory with respect to any other insurance carried by the additional insured;
2. Such written contract or written agreement is in effect during this "policy period" and executed prior to the "occurrence" of the "bodily injury" or "property damage"; and
3. Coverage required by such written contract or written agreement is provided in the applicable and collectible "scheduled underlying insurance" or would have been provided but for the exhaustion of the underlying limits of insurance;

then notwithstanding any other provisions of this policy to the contrary, including, Paragraph K., **Other Insurance** of **SECTION VI - CONDITIONS**, with respect to those additional insureds added through written contract or written agreement for which coverage is provided pursuant to Subparagraph J.2.e. of **SECTION V - DEFINITIONS**, insurance provided under this policy shall be primary and non-contributory with respect to any other insurance providing coverage to such additional insureds, other than "scheduled underlying insurance".

Notwithstanding the foregoing under no circumstances will coverage provided to such additional insureds under this policy be broader than the coverage provided under the "scheduled underlying insurance".

This endorsement shall not reinstate or increase the limits of insurance shown on the Declarations.

All other terms and conditions of the policy remain the same.



\_\_\_\_\_  
**Authorized Representative**

2. You have failed to fulfill the terms of a contract or agreement;

if such property can be restored to use by:

1. The repair, replacement, adjustment or removal of "your product" or "your work"; or
2. Your fulfilling the terms of the contract or agreement.

**J. "Insured" means:**

1. The "Named Insured";

2. Except for liability arising out of the ownership, maintenance, or use of "covered autos";

a. If you are designated in the Declarations as:

(1) An individual, you and your spouse are "Insureds", but only with respect to the conduct of a business of which you are the sole owner;

(2) A partnership or joint venture, you are an "Insured". Your members and your partners, and their spouses are also "Insureds", but only with respect to the conduct of your business;

A limited liability company, you are an "Insured". Your members are also "Insureds", but only with respect to the conduct of your business. Your managers are "Insureds", but only with respect to their duties as your managers;

(3) An organization other than a partnership, joint venture or limited liability company, you are an "Insured". Your "executive officers" and directors are "Insureds", but only with respect to their duties as your officers or directors. Your stockholders are also "Insureds", but only with respect to their liability as stockholders;

(4) A trust, you are an "Insured". Your trustees are also "Insureds", but only with respect to their duties as trustees;

b. Your "volunteer workers" only while performing duties related to the conduct of your business. Your "employees" other than your "executive officers" (if you are an organization other than a partnership, joint venture or limited liability company) or your managers (if you are a limited liability company), but only for acts within the scope of their employment by you or while performing duties related to the conduct of your business. However, none of these "employees" or "volunteer workers" are insureds for:

(1) "Bodily injury" or "personal and advertising injury":

(a) To you, to your partners or members (if you are a partnership or joint venture), to your members (if you are a limited liability company), to a co-"employee" in the course of his or her employment or performing duties related to the conduct of your business or to your other "volunteer workers" while performing duties related to the conduct of your business; or any claim or "suit" brought by or on behalf of the spouse, child, parent, brother or sister of that co-"employee" or "volunteer worker" as a consequence of such "bodily injury" or "personal and advertising injury", or;

For which there is any obligation to share damages with or repay someone else who must pay (b) damages because of the injury described in Paragraphs (1)(i) above.

(2) "Property damage" to property:

(a) Owned, occupied or used by,

(b) Rented to, in the care, custody or control of, or over which physical control is being exercised for any purpose by you, any of your "employees", "volunteer workers", any partner or member (if you are a partnership or joint venture), or any member (if you are a limited liability company).

c. Any person (other than your "employee" or "volunteer worker") or organization while acting as your real estate manager;

d. Your legal representative if you die, but only with respect to duties as such. That representative will have all your rights and duties under this policy;

- e. Any person or organization, other than the "Named Insured", included as an additional "Insured" under "scheduled underlying insurance", but not for broader coverage than would be afforded by such "scheduled underlying insurance".
3. Only with respect to liability arising out of the ownership, maintenance, or use of "covered autos":
- a. You are an "Insured";
  - b. Anyone else while using with your permission a "covered auto" you own, hire, or borrow is also an "Insured" except:
    - (1) The owner or anyone else from whom you hire or borrow a "covered auto". This exception does not apply if the "covered auto" is a trailer or semi-trailer connected to a "covered auto" you own; Your "employee" if the "covered auto" is owned by that "employee" or a member of his or her
    - (2) household;
      - Someone using a "covered auto" while he or she is working in a business of selling, servicing,
      - (3) repairing, parking or storing "autos" unless that business is yours;
      - Anyone other than your "employees", partners (if you are a partnership), members (if you are a
      - (4) limited liability company), or a lessee or borrower or any of their "employees", while moving property to or from a "covered auto";
      - A partner (if you are a partnership), or a member (if you are a limited liability company)
      - (5) for a "covered auto" owned by him or her or a member of his or her household;
      - "Employees" with respect to "bodily injury" to any fellow "employee" of the "Insured" arising out of
      - (6) and in the course of the fellow "employee's" employment or while performing duties related to the conduct of your business;
  - c. Anyone liable for the conduct of an "Insured" described above is also an "Insured", but only to the extent of that liability.
4. Notwithstanding any of the above:
- a. No person or organization is an "Insured" with respect to the conduct of any current, past or newly formed partnership, joint venture or limited liability company that is not designated as a "Named Insured" in Item 1 of the Declarations; and
  - b. No person or organization is an "Insured" under this policy who is not an "Insured" under "scheduled underlying insurance".
- K. "Insured contract" means that part of any contract or agreement pertaining to your business under which any "Insured" assumes the tort liability of another party to pay for "bodily injury" or "property damage" to a third person or organization. Tort liability means a liability that would be imposed by law in the absence of any contract or agreement.
- "Insured contract" does not include that part of any contract or agreement:
- 1. That indemnifies a railroad for "bodily injury" or "property damage" arising out of construction or demolition operations, within 50 feet of any railroad property and affecting any railroad bridge or trestle, tracks, road-beds, tunnel, underpass or crossing;
  - 2. That indemnifies an architect, engineer or surveyor for injury or damage arising out of:
    - a. Preparing, approving, or failing to prepare or approve, maps, shop drawings, opinions, reports, surveys, field orders, change orders or drawings and specifications; or
    - b. Giving directions or instructions, or failing to give them, if that is the primary cause of the injury or damage; or
  - 3. Under which the "Insured", if an architect, engineer or surveyor, assumes liability for an injury or damage arising out of the "Insured's" rendering or failure to render professional services, including those shown in subparagraph 2 above and supervisory, inspection, architectural or engineering activities.

## **J. Maintenance of Scheduled Underlying Insurance**

You agree that during the "policy period":

1. You will keep "scheduled underlying insurance" in full force and effect;
2. The terms, definitions, conditions and exclusions of "scheduled underlying insurance" will not materially change;
3. The total applicable limits of "scheduled underlying insurance" will not decrease, except for any reduction or exhaustion of aggregate limits by payment of damages to which this policy applies.
4. Any renewals or replacements of "scheduled underlying insurance" will provide equivalent coverage to and afford limits of insurance equal to or greater than the policy being renewed or replaced.

If you fail to comply with these requirements, we will be liable only to the same extent that we would have, had you fully complied with these requirements.

## **K. Other Insurance**

If other valid and collectible insurance applies to damages that are also covered by this policy, this policy will apply excess of the "other insurance". However, this provision will not apply if the other insurance is specifically written to be excess of this policy.

## **L. Premium and Audit**

1. We will compute all premiums for this policy in accordance with our rules and rates.
2. If the premium for this policy is a flat premium, it is not subject to adjustment, except that additional premiums may be required for any additional exposure and/or "Insureds", or as provided for in Condition D Cancellation. The premium shown in Item 5 of the Declarations as the Total Advance Premium is a deposit premium only. If the policy is subject to audit adjustment, the actual exposure base will be used to compute the earned premium. If the learned premium is greater than the Advance Premium, the first Named Insured will pay the difference to us due and payable upon notice. Subject to the Annual Minimum Premium shown in Item 5 of the Declarations, if the earned premium is less than the Total Advance Premium, we will return the difference to the first Named Insured.
3. The first Named Insured must keep records of the information we need for premium computation, and send us copies at such times as we may request. The first Named Insured shown on the Declarations is responsible for the payment of all premiums and will be the payee for any return premiums we pay.

## **M. Representations of Fraud**

By accepting this policy, you agree:

1. The statements in the Declarations are accurate and complete;
2. Those statements are based upon representations you made to us;
3. We have issued this policy in reliance upon your representations; and
4. This policy is void in any case of fraud by you as it relates to this policy or any claim or "suit" under this policy.

## **N. Separation of "Insureds"**

Except with respect to the limits of insurance of this policy and rights or duties specifically assigned to the first Named Insured designated in Item 1 of the Declarations, this insurance applies:

1. As if each "Named Insured" were the only "Named Insured"; and
2. Separately to each "Insured" against whom claim is made or "Suit" is brought.

## **O. Transfer of Rights of Recovery**

1. If any "Insured" has rights to recover all or part of any payment we have made under this policy, those rights are transferred to us. The "Insured" must do nothing after loss to impair these rights and must help us enforce them.

**2. Any recoveries will be applied as follows:**

- a. Any person or organization, including the "Insured", that has paid an amount in excess of the applicable limits of insurance of this policy will be reimbursed first;
- b. We then will be reimbursed up to the amount we have paid; and
- c. Lastly, any person or organization, including the "Insured" that has paid an amount over which this policy is excess is entitled to claim the remainder.

Expenses incurred in the exercise of rights of recovery will be apportioned among the persons or organizations, including the "Insured", in the ratio of their respective recoveries as finally settled.

- 3. If, prior to the time of an "occurrence", you and the insurer of "scheduled underlying insurance" waive any right of recovery against a specific person or organization for injury or damage as required under an "insured contract", we will also waive any rights we may have against such person or organization.**

**P. Transfer of Your Rights and Duties**

Your rights and duties under this policy may not be transferred without our written consent.

If you die or are legally declared bankrupt, your rights and duties will be transferred to your legal representative, but only while acting within the scope of duties as your legal representative. However, notice of cancellation sent to the first "Named Insured" designated in Item 1 of the Declarations and mailed to the address shown in this policy will be sufficient notice to effect cancellation of this policy.

**Q. Service of Suit**

It is agreed that in the event of our failure to pay any amount claimed to be due hereunder, we, at the request of the "Insured", will submit jurisdiction of a court of competent jurisdiction within the United States. Nothing in this condition constitutes or should be understood to constitute a waiver of our rights to commence an action in any court of competent jurisdiction in the United States, to remove an action to a United States District Court or to seek a transfer of a case to another court as permitted by the laws of the United States or of any state in the United States. It is further agreed that service of process may be made upon Counsel, Legal Department, Lexington Insurance Company, 100 Summer Street, Boston, MA 02110, or his or her representative, and that in any "suit" instituted against us, upon this policy, we will abide by the final decision of such court or of an appellate court in the event of an appeal.

Further, pursuant to any statute of any state, territory, or district of the United States which makes provision therefor, we hereby designate the Superintendent, Commissioner, Director of Insurance, or other officer specified for that purpose in the statute, or his or her successor or successors in office as our true and lawful attorney upon whom may be served any lawful process in any action, "suit" or proceeding instituted by or on behalf of you or any beneficiary hereunder arising out of this contract of insurance, and hereby designate the Counsel, Legal Department, Lexington Insurance Company, 100 Summer Street, Boston, MA 02110, as the person to whom the said officer is authorized to mail such process or a true copy thereof.

**R. Arbitration**

Notwithstanding Condition Q. Service of Suit, above, in the event of a disagreement as to the interpretation of this policy (except with regard to whether this policy is void or voidable), it is mutually agreed that such dispute shall be submitted to binding arbitration before a panel of three (3) Arbitrators consisting of two (2) party-nominated (non-impartial) Arbitrators and a third (impartial) Arbitrator (hereinafter "umpire") as the sole and exclusive remedy.

The party desiring arbitration of a dispute shall notify the other party, said notice including the name, address and occupation of the Arbitrator nominated by the demanding party. The other party shall, within 30 days following receipt of the demand, notify in writing the demanding party of the name, address and occupation of the Arbitrator nominated by it. The two (2) arbitrators so selected shall, within 30 days of the appointment of the second Arbitrator, select an umpire. If the Arbitrators are unable to agree upon an umpire, the selection of the umpire shall be submitted to the Judicial Arbitration and Mediation Services (hereinafter, "JAMS"). The umpire shall be selected in accordance with Rule 15 (as may be amended from time to time) of the JAMS Comprehensive Arbitration Rules and Procedures for the selection of a sole arbitrator.

## COMMERCIAL EXCESS LIABILITY DECLARATIONS

---

**Policy Number:** USXSL0041523

---

**Named Insured and Mailing Address:**

Apollo Sheet Metal, Inc.  
1133 W Columbia Drive  
Kennewick, WA 99336

**Policy Period:** 04/01/2023 To 04/01/2024  
(12:01 A.M. Standard time at the address of the Insured shown above)

---

IN RETURN FOR THE PAYMENT OF THE PREMIUM AND SUBJECT TO ALL THE TERMS  
OF THIS POLICY, WE AGREE WITH YOU TO PROVIDE THE INSURANCE AS STATED IN THIS POLICY.

---

**Insurer:**

Upland Specialty Insurance Company - AM Best Rating A-VIII Non-Admitted  
5050 Quorum Drive, Suite 700-#473  
Dallas, TX 75254

**Producer Name:** Amwins - Brokerage of Washington

**Audit Period (If Applicable):**

---

**Premium:** Total Advance Premium:  
Minimum Term Premium:  
Terrorism Premium:

**Minimum Earned in event of Cancellation: 35%**

---

**Limits of Insurance:**

\$7,000,000 Each Occurrence Limit  
\$7,000,000 Aggregate Limit (where applicable)

These Limits of Insurance apply in excess of those limits in the Schedule of Underlying Insurance indicated below.

**Schedule of Underlying Insurance:** See attached (Form No. UE 00 04 04 21)

**Name Insured:** Apollo Sheet Metal, Inc.

**Policy Number:** USXSL0041523

## FORMS AND ENDORSEMENTS

It is hereby understood and agreed the following forms and endorsements are attached to and are a part of this policy:

Form Number	Form / Endorsement Title
UE 00 01 04 21	Excess Liability Policy Declarations
UC 00 03 02 21	Forms and Endorsements
UE 00 04 04 21	Schedule of Underlying Insurance
CX 00 01 04 13	Commercial Excess Liability Coverage Form
UC 00 06 01 22	Claims Reporting Procedures
UC 00 04 02 21	U.S. Treasury Department's Office of Foreign Assets Control ("OFAC") Advisory
UC 00 02 01 22	Service of Suit
CX 21 33 01 15	Exclusion of Certified Acts of Terrorism
UC SLWA 02 21	WA Surplus Lines Notice
XS 00 02 10 22	Exclusion - Biometric Information Privacy Claims
XS 00 03 08 21	Non-Stacking of Occurrence Limits Endorsement
XS 00 06 08 21	Change in Risk Endorsement
UX 00 42 03 21	Exclusion - Communicable Disease
XS 00 08 08 21	Exclusion - Cyber
CX 21 43 05 14	Exclusion - Access or Disclosure of Confidential or Personal Information
CX 21 01 09 08	Nuclear Energy Liability Exclusion Endorsement
XS 00 01 08 21	Limitation of Coverage - Trade or Economic Sanctions
UX 00 09 02 21	Exclusion - Exterior Insulation and Finish Systems (EIFS)
XS 00 37 12 21	Exclusion - Lead
XS 00 38 12 21	Exclusion - Asbestos
XS 00 32 12 21	Exclusion - Continuing or Resuming Damage
XS 00 13 10 21	Non-Contributory Endorsement
UX 00 13 02 21	Exclusion - Punitive Damages
XS 00 31 12 21	Exclusion - Your Work in New York
CX 21 13 04 13	Exclusion - Fungi or Bacteria
CX 21 20 04 13	Exclusion - Professional Services
CX 21 16 04 13	Exclusion - Silica or Silica-Related Dust
CX 21 03 04 13	Total Pollution Exclusion with a Hostile Fire Exception
CX 21 19 04 13	Exclusion - Employment-Related Practices
UX 00 10 02 21	Exclusion - ERISA
XS 00 19 10 21	Exclusion - Designated Operations Covered By A Consolidated (Wrap-Up)
UX 00 04 02 21	Limitation - Coverage Territory
CX 01 06 08 10	Washington Changes
CX 01 27 11 13	Washington Changes - Defense Costs
UC 00 07 02 21	Signature Page



<b>Name Insured:</b> Apollo Sheet Metal, Inc.	<b>Policy Number:</b> USXSL0041523
---	------------------------------------

**SCHEDULE OF UNDERLYING INSURANCE**

<b>Coverage:</b>	Excess Liability	
<b>Carrier:</b>	Lexington Insurance Company	
<b>Policy Term:</b>	04/01/2023 - 04/01/2024	
<b>Policy Number:</b>	29316160	
<b>Controlling:</b>	Yes	
<b>Limits of Liability:</b>	\$3,000,000	Each Occurrence
	\$3,000,000	Products/Completed Operations
	\$3,000,000	General Aggregate

Which is in Excess of Underlying Policies as Scheduled on the Controlling Underlying Policy

# COMMERCIAL EXCESS LIABILITY COVERAGE FORM

Various provisions in this policy restrict coverage. Read the entire policy carefully to determine rights, duties and what is and is not covered.

Throughout this policy the words "you" and "your" refer to the Named Insured shown in the Declarations, and any other person or organization qualifying as a Named Insured under this policy. The words "we", "us" and "our" refer to the company providing this insurance. The word "insured" means any person or organization qualifying as such under the "controlling underlying insurance".

Other words and phrases that appear in quotation marks in this Coverage Part have special meaning. Refer to Section IV – Definitions. Other words and phrases that are not defined under this Coverage Part but defined in the "controlling underlying insurance" will have the meaning described in the policy of "controlling underlying insurance".

The insurance provided under this Coverage Part will follow the same provisions, exclusions and limitations that are contained in the applicable "controlling underlying insurance", unless otherwise directed by this insurance. To the extent such provisions differ or conflict, the provisions of this Coverage Part will apply. However, the coverage provided under this Coverage Part will not be broader than that provided by the applicable "controlling underlying insurance".

There may be more than one "controlling underlying insurance" listed in the Declarations and provisions in those policies conflict, and which are not superseded by the provisions of this Coverage Part. In such a case, the provisions, exclusions and limitations of the "controlling underlying insurance" applicable to the particular "event" for which a claim is made or suit is brought will apply.

## SECTION I – COVERAGES

### 1. Insuring Agreement

- a. We will pay on behalf of the insured the "ultimate net loss" in excess of the "retained limit" because of "injury or damage" to which insurance provided under this Coverage Part applies.

We will have the right and duty to defend the insured against any suit seeking damages for such "injury or damage" when the applicable limits of "controlling underlying insurance" have been exhausted in accordance with the provisions of such "controlling underlying insurance".

When we have no duty to defend, we will have the right to defend, or to participate in the defense of, the insured against any other suit seeking damages for "injury or damage".

However, we will have no duty to defend the insured against any suit seeking damages for which insurance under this policy does not apply.

At our discretion, we may investigate any "event" that may involve this insurance and settle any resultant claim or suit, for which we have the duty to defend.

But:

- (1) The amount we will pay for "ultimate net loss" is limited as described in Section II – Limits Of Insurance; and
  - (2) Our right and duty to defend ends when we have used up the applicable limit of insurance in the payment of judgments or settlements under this Coverage Part. However, if the policy of "controlling underlying insurance" specifies that limits are reduced by defense expenses, our right and duty to defend ends when we have used up the applicable limit of insurance in the payment of defense expenses, judgments or settlements under this Coverage Part.
- b. This insurance applies to "injury or damage" that is subject to an applicable "retained limit". If any other limit, such as, a sublimit, is specified in the "controlling underlying insurance", this insurance does not apply to "injury or damage" arising out of that exposure unless that limit is specified in the Declarations under the Schedule of "controlling underlying insurance".
  - c. If the "controlling underlying insurance" requires, for a particular claim, that the "injury or damage" occur during its policy period in order for that coverage to apply, then this insurance will only apply to that "injury or damage" if it occurs during the policy period of this Coverage Part. If the "controlling underlying insurance" requires that the "event" causing the particular "injury or damage" takes place during its policy period in order for that coverage to apply, then this insurance will apply to the claim only if the "event" causing that "injury or damage" takes place during the policy period of this Coverage Part.

d. Any additional insured under any policy of "controlling underlying insurance" will automatically be an additional insured under this insurance. If coverage provided to the additional insured is required by a contract or agreement, the most we will pay on behalf of the additional insured is the amount of insurance required by the contract, less any amounts payable by any "controlling underlying insurance".

Additional insured coverage provided by this insurance will not be broader than coverage provided by the "controlling underlying insurance".

## 2. Exclusions

The following exclusions, and any other exclusions added by endorsement, apply to this Coverage Part. In addition, the exclusions applicable to any "controlling underlying insurance" apply to this insurance unless superseded by the following exclusions, or superseded by any other exclusions added by endorsement to this Coverage Part.

Insurance provided under this Coverage Part does not apply to:

### a. Medical Payments

Medical payments coverage or expenses that are provided without regard to fault, whether or not provided by the applicable "controlling underlying insurance".

### b. Auto

Any loss, cost or expense payable under or resulting from any of the following auto coverages:

- (1) First-party physical damage coverage;
- (2) No-fault coverage;
- (3) Personal injury protection or auto medical payments coverage; or
- (4) Uninsured or underinsured motorists coverage.

### c. Pollution

- (1) "Injury or damage" which would not have occurred, in whole or in part, but for the actual, alleged or threatened discharge, dispersal, seepage, migration, release or escape of pollutants at any time.
- (2) Any loss, cost or expense arising out of any:
  - (a) Request, demand, order or statutory or regulatory requirement that any insured or others test for, monitor, clean up, remove, contain, treat, detoxify or neutralize, or in any way respond to, or assess the effects of, pollutants; or

(b) Claim or suit by or on behalf of a governmental authority for damages because of testing for, monitoring, cleaning up, removing, containing, treating, detoxifying or neutralizing, or in any way responding to, or assessing the effects of, pollutants.

This exclusion does not apply to the extent that valid "controlling underlying insurance" for the pollution liability risks described above exists or would have existed but for the exhaustion of underlying limits for "injury or damage".

### d. Workers' Compensation And Similar Laws

Any obligation of the insured under a workers' compensation, disability benefits or unemployment compensation law or any similar law.

## SECTION II – LIMITS OF INSURANCE

1. The Limits of Insurance shown in the Declarations, and the rules below fix the most we will pay regardless of the number of:

- a. Insureds;
- b. Claims made or suits brought, or number of vehicles involved;
- c. Persons or organizations making claims or bringing suits; or
- d. Limits available under any "controlling underlying insurance".

2. The Limits of Insurance of this Coverage Part will apply as follows:

- a. This insurance only applies in excess of the "retained limit".
- b. The Aggregate Limit is the most we will pay for the sum of all "ultimate net loss", for all "injury or damage" covered under this Coverage Part. However, this Aggregate Limit only applies to "injury or damage" that is subject to an aggregate limit of insurance under the "controlling underlying insurance".
- c. Subject to Paragraph 2.b. above, the Each Occurrence Limit is the most we will pay for the sum of all "ultimate net loss" under this insurance because of all "injury or damage" arising out of any one "event".
- d. If the Limits of Insurance of the "controlling underlying insurance" are reduced by defense expenses by the terms of that policy, any payments for defense expenses we make will reduce our applicable Limits of Insurance in the same manner.

## NON-CONTRIBUTORY ENDORSEMENT

This endorsement modifies insurance provided under the following:

Commercial Excess Liability

Schedule
<p><b>Name of Additional Insured Person(s) or Organization(s):</b>            Any person or organization when you have executed a written contract or other written agreement, prior to an "occurrence" that causes "bodily injury," "property damage," or "personal and advertising injury," and that contract or agreement stated, at the time of execution, that such person or organization would be added as an additional insured on your policy.</p>

Paragraph 8. of **Section III – Conditions** is replaced by the following:

### 8. Other Insurance

- a. This insurance is excess over, and shall not contribute with other insurance, whether primary, excess, contingent or on any other basis. However:
  - (1) This condition will not apply to other insurance specifically written as excess over this Coverage Part.
  - (2) This policy will not seek contribution from any other Commercial General Liability insurance, Commercial Excess Liability insurance, or when included in the Schedule of Underlying, Auto Liability insurance or Employers Liability insurance, that is available to an additional insured, but only if:
    - (a) The additional insured is a Named Insured under such other insurance;
    - (b) The additional insured is identified in, or otherwise falls within the language of, the above Schedule or the Schedule of any other Noncontributory-Other Insurance Condition endorsement form made part of this policy;
    - (c) The "controlling underlying insurance" provides primary and non-contributory coverage to the same additional insured; and
    - (d) Prior to the effective date of this policy, you agreed in writing in a contract or agreement that this insurance would not seek contribution from such other insurance.
- b. When this insurance is excess, if no other excess insurer defends, we may undertake to do so, but we will be entitled to the insured's rights against all other insurers.
- c. When this insurance is excess, the most we will pay will be a share of "ultimate net loss" that exceeds the sum of:
  - (1) The total amount that all other insurance would pay for the loss in the absence of the insurance provided under this Coverage Part; and
  - (2) The total of all deductible and self-insured amounts under all other insurance.

**Notwithstanding any part of this endorsement, coverage granted to an additional insured remains subject to all terms, conditions, limitations, and exclusions set forth in the endorsement form that conferred the additional insured status.**

All other terms and conditions of this Policy remain unchanged.

## SCHEDULE OF FORMS AND ENDORSEMENTS

It is hereby understood and agreed the following forms and endorsements are attached to and are part of this **Policy**:

### SCHEDULE

Endt. No.	Form No.	Form Title
	SN 9044 0914 WA	Surplus Lines Notice (WA)
	IL 0101 0712	Schedule of Forms and Endorsements
	CPL 00 02 0520	Contractors Professional and Pollution Liability – Occurrence Declarations
	CPL 0204 0420	Contractors Professional and Pollution Liability – Occurrence Policy
1	CPL 03 16 0520	Scheduled Ancillary Location(s)
2	CPL 0340 0621	Retroactive Date Amendment for Higher Limit
3	CPL 0343 0821	Notice of Cancellation - 90 Days
4	IL 1205 0115	Exclusion of Certified Acts of Terrorism
5	IL 1313 0115	Disclosure Pursuant to Terrorism Risk Insurance Act - Rejection of Offer
6	IL 1301 0712	Service of Suit
	PN 0001 0712	OFAC Notice to Policy Holders
	IL 1008 0114	Authorized Representative Signature

This contract is registered and delivered as a surplus line coverage under the insurance code of the state of Washington, Title 48RCW. It is not protected by any Washington state guaranty association law.

Surplus Line Broker: Daniel Beck

## CONTRACTORS PROFESSIONAL AND POLLUTION LIABILITY DECLARATIONS (OCCURRENCE FORM)

FOR THOSE COVERAGES THAT ARE IDENTIFIED AS APPLYING ON A CLAIMS-MADE BASIS, THIS POLICY CONTAINS COVERAGES THAT ARE LIMITED TO CONDITIONS THAT ARE DISCOVERED AND REPORTED DURING THE POLICY PERIOD OR ANY EXTENDED REPORTING PERIOD(S) FOR CLAIMS THAT ARE FIRST MADE AND REPORTED TO THE INSURER WITHIN THE POLICY PERIOD OR, IF APPLICABLE, THE EXTENDED REPORTING PERIOD(S). THIS POLICY DOES NOT PROVIDE COVERAGE FOR CLAIMS ARISING OUT OF CONDITIONS THAT TOOK PLACE PRIOR TO THE APPLICABLE RETROACTIVE DATE.

PLEASE READ THIS POLICY CAREFULLY. SOME OF THE PROVISIONS CONTAINED IN THIS POLICY RESTRICT COVERAGE, SPECIFY WHAT IS AND IS NOT COVERED AND DESIGNATE YOUR RIGHTS AND DUTIES. LEGAL DEFENSE EXPENSES, INCLUDING ATTORNEY FEES AND EXPENSES, ARE SUBJECT TO AND SHALL ERODE THE LIMITS OF LIABILITY AND ANY APPLICABLE SELF-INSURED RETENTION.

THE DECLARATIONS, TOGETHER WITH THE COMPLETED AND SIGNED APPLICATION, THIS POLICY, AND ANY ENDORSEMENTS OR SCHEDULES ATTACHED HERETO, CONSTITUTE THE INSURANCE POLICY.

**POLICY NUMBER:** PNV10015059602

Item 1. **Named Insured:** APOLLO SHEET METAL, INC.  
dba APOLLO MECHANICAL CONTRACTORS  
**Address:** 1133 Columbia Drive  
Kennewick, WA 99336

Item 2. **Policy Period:** **From: 4/1/2023** **To: 4/1/2024**  
(Both dates at 12:01 AM at the address of the **Named Insured.**)

Item 3. **Total Coverage Part Premium:**  
**TRIA:**  
**Total Premium:**  
**Minimum Earned Premium:**

Item 4. **Producer:** SYNAPSE SERVICES, LLC  
**Address:** 1900 Wazee Street, Unit 150  
Denver, CO 80202

Item 5. **Endorsements Effective at Inception:**  
See attached Forms and Endorsements Schedule IL 0101 0712

Item 6. Coverage Schedule:

Coverage Section Insuring Agreements	Limit of Liability* Each Claim/Aggregate	Self-Insured Retention**	Retroactive Date
A. Coverage A – Covered Operations:	\$10,000,000/\$10,000,000	\$100,000	N/A - Occurrence
B. Coverage B – Insured’s Locations:	\$10,000,000/\$10,000,000	\$100,000	Time Element
C. Coverage C – Non-Owned Disposal Sites:	\$10,000,000/\$10,000,000	\$100,000	N/A - Occurrence
D. Coverage D – Public Relation Expenses:	\$250,000/ \$250,000	\$100,000	9/30/2020
E. Coverage E – Professional Liability:	\$10,000,000/\$10,000,000	\$100,000	5/12/2019
F. Coverage F – Protective Professional Liability:	\$5,000,000/ \$5,000,000	N/A	5/12/2019
G. Coverage G – Mitigation of Loss:	\$5,000,000/ \$5,000,000	\$100,000	5/12/2019

\*If no Limit of Liability appears for a specific Coverage Section, there is no coverage for that Coverage Section under the Policy.

\*\* If two or more Self-Insured Retentions apply to the same Claim, only the single highest Self-Insured Retention shall apply.

Item 7. Maximum Aggregate Limit of Liability: \$10,000,000

Item 8. Separate Defense Expenses Limit: \$1,000,000

Item 9. Notice of Claim or Potential Claim:

**E-Mail**

[Insuranceclaims@sompo-intl.com](mailto:Insuranceclaims@sompo-intl.com)

Submission of Notice of Claims by email is preferred.

**Mail**

Sompo International – US Environmental  
Attn: Claims Department  
1221 Avenue of the Americas  
18<sup>th</sup> Floor  
New York, NY 10020

The Company hereby causes this **Policy** to be signed on the Declarations page by a duly authorized representative of the Company.

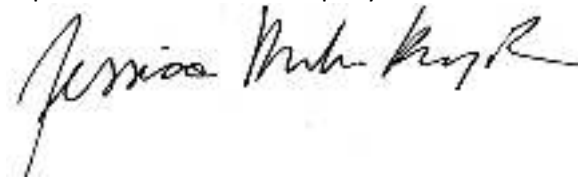

Authorized Representative

4/1/2023

Date

# CONTRACTORS PROFESSIONAL AND POLLUTION LIABILITY POLICY (OCCURRENCE FORM)

FOR THOSE COVERAGES THAT ARE IDENTIFIED AS APPLYING ON A CLAIMS-MADE BASIS, SUCH COVERAGES ARE LIMITED TO CONDITIONS THAT ARE DISCOVERED AND REPORTED DURING THE POLICY PERIOD OR ANY EXTENDED REPORTING PERIOD(S) FOR CLAIMS THAT ARE FIRST MADE AND REPORTED TO THE INSURER WITHIN THE POLICY PERIOD OR, IF APPLICABLE, THE EXTENDED REPORTING PERIOD(S). THIS POLICY DOES NOT PROVIDE COVERAGE FOR CLAIMS ARISING OUT OF CONDITIONS THAT TOOK PLACE PRIOR TO THE APPLICABLE RETROACTIVE DATE. READ THE ENTIRE POLICY CAREFULLY TO DETERMINE YOUR RIGHTS, DUTIES AND WHAT IS AND WHAT IS NOT COVERED.

DEFENSE EXPENSES, INCLUDING ATTORNEY FEES AND EXPENSES, ARE INCLUDED WITHIN AND ERODE THE LIMITS OF LIABILITY. OTHER WORDS AND PHRASES THAT APPEAR IN BOLD HAVE SPECIAL MEANING. REFER TO THE DEFINITIONS SECTION.

In consideration of premium paid or payable and in reliance on all statements made and information furnished by the **Insureds** in the underwriting of this **Policy**, and subject to the terms and conditions of this **Policy**, the insurer identified in the Declarations (herein referred to as the "Company") agrees as follows:

## I. INSURING AGREEMENTS

ONLY THOSE COVERAGES WITH A SPECIFIC LIMIT OF INSURANCE SHOWN IN THE DECLARATIONS ARE APPLICABLE.

### A. COVERAGE A – COVERED OPERATIONS

The Company shall pay, up to the Limits of Liability and in excess of the Self-Insured Retention as specified in the Declarations, on behalf of the **Insured** for:

1. **Cleanup Costs, Bodily Injury or Property Damage** that the **Insured** becomes legally obligated to pay; and
2. **Defense Expenses;**

that result from **Pollution Condition(s)** or **Biological Agent Condition(s)** caused by **Covered Operations**.

This coverage applies only if the **Environmental Damage, Bodily Injury or Property Damage** occurs during the **Policy Period**.

If the same **Pollution Condition(s)** or **Biological Agent Condition(s)**, or series of related **Pollution Condition(s)** or **Biological Agent Condition(s)**, results in **Environmental Damage, Bodily Injury, or Property Damage** that occurs over the **Policy Periods** of two or more Contractor's Pollution Liability policies issued by the Company, such **Environmental Damage, Bodily Injury or Property Damage** will be deemed to have occurred only during the **Insured's** first such policy under which the **Environmental Damage, Bodily Injury or Property Damage** is covered. This shall apply even if the date that the **Environmental Damage, Bodily Injury or**



**Property Damage** first occurred is prior to the **Policy Period** or is unknown, provided that, the **Environmental Damage, Bodily Injury or Property Damage** occurs during the **Policy Period** of this **Policy**. Related **Pollution Condition(s)** or **Biological Agent Condition(s)** are those **Pollution Condition(s)** or **Biological Agent Condition(s)** that arise out of, are based on, relate to, or are in consequence of, the same or related or series of related facts, events, circumstances or situations.

B. COVERAGE B – INSURED’S LOCATIONS

THIS COVERAGE APPLIES ON A CLAIMS-MADE BASIS.

The Company shall pay, up to the Limits of Liability and in excess of the Self-Insured Retention as specified in the Declarations, on behalf of the **Insured** for:

1. **Cleanup Costs;**
2. **Bodily Injury or Property Damage** that the **Insured** becomes legally obligated to pay; and
3. **Defense Expenses;**

that result from **Pollution Condition(s)** at, upon, within, under or migrating from:

- a. A **Scheduled Location** which commenced on or after the applicable **Retroactive Date**, and before the **Policy** terminates, provided that the **Claim** for such **Pollution Condition(s)** is first made and the **Pollution Condition(s)** is first discovered during the **Policy Period**, and reported to the Company during the **Policy Period**, the Automatic Extended Reporting Period or the Optional Extended Reporting Period, if any; or
- b. An **Ancillary Location** which commenced on or after the **Policy** inception date and before the **Policy** terminates, provided that such **Pollution Condition(s)** is first discovered no more than ten (10) days after commencement of such **Pollution Condition(s)** and reported to the Company no later than thirty (30) days after the commencement of such **Pollution Condition(s)**, but in any event during the **Policy Period**, the Automatic Extended Reporting Period, or the Optional Extended Reporting Period, if any.

C. COVERAGE C – NON-OWNED DISPOSAL SITES

The Company shall pay, up to the Limits of Liability and in excess of the Self-Insured Retention as specified in the Declarations, on behalf of the **Insured** for:

1. **Cleanup Costs, Bodily Injury or Property Damage** that the **Insured** becomes legally obligated to pay to parties other than owners, operators or contractors of **Non-owned Disposal Sites**; and
2. **Defense Expenses;**

resulting from **Pollution Condition(s)** in the processing, treatment or disposal, or the arranging for the processing, treatment or disposal, of waste at, upon, within, under or migrating from **Non-owned Disposal Sites**. This coverage applies only if such waste first originates from **Covered Operations** performed by or on behalf of the **Insured**, provided that:

The **Environmental Damage, Bodily Injury or Property Damage** occur during the **Policy Period**. If the same **Pollution Condition(s)** or series of related **Pollution Condition(s)** results in **Environmental Damage, Bodily Injury or Property Damage** that occurs over the **Policy Periods**

of two or more Contractor's Pollution Liability policies issued by the Company, such **Environmental Damage, Bodily Injury or Property Damage** will be deemed to have occurred only during the **Insured's** first such policy under which the **Environmental Damage, Bodily Injury or Property Damage** is covered. This shall apply even if the date that the **Environmental Damage, Bodily Injury or Property Damage** first occurred is prior to the **Policy Period** or is unknown, provided the **Environmental Damage, Bodily Injury or Property Damage** occurs during the **Policy Period** of this **Policy**. Related **Pollution Condition(s)** are those **Pollution Condition(s)** that arise out of, are based on, relate to, or are in consequence of, the same or related or series of related facts, events, circumstances or situations.

D. COVERAGE D – PUBLIC RELATION EXPENSES

The Company shall reimburse the **Insured**, up to the Limits of Liability and in excess of the Self-Insured Retention as specified in the Declarations, for **Public Relation Expenses** resulting from **Pollution Condition(s)** or **Biological Agent Condition(s)** or a **Wrongful Act(s)** to which coverage applies under COVERAGE A, COVERAGE B or COVERAGE C, or COVERAGE E of this **Policy**.

E. COVERAGE E – PROFESSIONAL LIABILITY

THIS COVERAGE APPLIES ON A CLAIMS-MADE BASIS.

The Company shall pay, up to the Limits of Liability and in excess of the Self-Insured Retention as specified in the Declarations, on behalf of the **Insured** for

1. **Damages;** and
2. **Defense Expenses;**

that result from a **Wrongful Act(s)** in the performance of or failure to perform **Professional Services**.

This coverage applies only if:

- a. Such **Professional Services** are performed on or after the **Retroactive Date** and before the end of the **Policy Period**; and
- b. The **Claim** is first made against the **Insured** during the **Policy Period**, and reported to the Company during the **Policy Period**, the Automatic Extended Reporting Period, or the Optional Extended Reporting Period, if any

F. COVERAGE F – PROTECTIVE PROFESSIONAL LIABILITY

THIS COVERAGE APPLIES ON A CLAIMS-MADE BASIS.

The Company shall reimburse the **Insured**, up to the Limits of Liability as specified in the Declarations, for **Ultimate Loss** in excess of all applicable limits of liability of the **Design Professionals Insurance** provided that:

1. the **Ultimate Loss** arise out of **Professional Services** performed on or after the **Retroactive Date** and before the end of the **Policy Period**;

2. the **Protective Claim** for such **Ultimate Loss** is first made by the **Insured** during the **Policy Period** and reported to the Company during the **Policy Period**, the Automatic Extended Reporting Period or the Optional Extended Reporting Period, if any; and
3. the **Insured** has done all that is reasonable and legally permitted in seeking recovery for **Ultimate Loss**.

#### G. COVERAGE G – MITIGATION OF LOSS

The Company shall indemnify the **Insured**, up to the Limits of Liability and in excess of the Self-Insured Retention as specified in the Declarations, for **Mitigation Costs** provided that:

1. the **Covered Operations** or **Professional Services** took place on or after the **Retroactive Date** and before the end of the **Policy Period**;
2. the **Insured** notifies the Company in writing during the **Policy Period** of the circumstances that would reasonably be expected to lead to such **Claim**; and
3. prior written approval by the Company is given after the **Insured** demonstrates that mitigation is reasonable and necessary to prevent or avoid a covered **Claim**.

However, the prior written approval of the Company shall not be required when necessary **Emergency Mitigation Action** is taken within 72 hours after a **Pollution Condition** or **Biological Agent Condition** has been discovered.

## II. DEFENSE, SETTLEMENT and COOPERATION

### A. DEFENSE AND SETTLEMENT OF CLAIMS

The Company has the right and the duty to defend the **Insured** against any **Claim** to which this **Policy** applies, and may, investigate and settle such **Claims**. The Company shall have the right to designate legal counsel for the investigation, adjustment and defense of **Claims**. The Company's duty to defend any **Claim** shall commence upon notice of a **Claim**, but the Company's duty to pay **Defense Expenses** shall commence only upon the **Insured's** satisfaction of the Self-Insured Retention set forth in the Declarations.

In the event the **Insured** has the legal right to designate independent counsel, the Company will only be obligated to reimburse **Defense Expenses** for such independent counsel at those rates that the Company pays to counsel it retains in the ordinary course of business in the defense of similar claims in the geographical area where the **Claim** is being defended.

The Company's duty to defend the **Insured** shall terminate when the Company establishes: (i) the absence of coverage under the terms and conditions of this **Policy**; or (ii) the Limits of Liability have been exhausted. In such circumstance, the Company shall take reasonably appropriate steps to transfer control of any existing defense to the **Insured**.

The **Insureds** shall not settle or offer to settle any **Claim**, incur **Defense Expenses**, admit any liability, stipulate to any judgment, or otherwise assume any obligation with respect to any **Claim** without the prior written consent of the Company, which shall not be unreasonably withheld. The Company shall not be liable for **Cleanup Costs, Bodily Injury, Property Damage, Environmental Damage, Public Relations Expenses, Ultimate Loss, or Damages** as a result of any offer to settle, settlement, assumed obligation, admission of liability, stipulated judgment, or

**Defense Expenses** to which it has not consented. However, if the **Insureds** are able to fully and finally settle, with prejudice, all **Claims** subject to a single Self-Insured Retention for an aggregate amount, including **Defense Expenses**, that does not exceed such Self-Insured Retention, then the Company's consent is not required for such settlement.

The Company shall have the right to make any investigation it deems necessary and, with the written consent of the **Insured**, make any settlement of a **Claim** covered by this **Policy**. If the Company recommends settlement of a **Claim**, the claimant is willing to agree to such settlement, and the **Insured** refuses to give written consent to settlement as recommended by the Company, then the **Insured** thereafter shall negotiate or defend such **Claim** independently of the Company and on the **Insured's** own behalf. In such event, the Company's liability for any such **Claim** shall be limited to the amount of the proposed settlement, plus **Defense Expenses** incurred up to the time that the **Insured** refused to agree to the proposed settlement, provided that the Company's liability under this **Policy** for such **Claim** shall not exceed the remaining portion of the applicable Limit of Liability.

#### B. COOPERATION

The **Insureds** agree to provide the Company with all information, assistance, and cooperation that the Company reasonably requests with respect to any **Claim**, including, but not limited to, submitting to examination by the Company's representative, attending hearings and depositions, and assisting the Company in the investigation and defense of a **Claim**. The **Insureds** agree that they will not knowingly take any action that will prejudice the Company's position or its potential or actual rights of recovery with respect to any amounts paid under this **Policy**. The **Insureds** shall forward to the Company every demand, pleading, notice, or other process received by or on behalf of the **Insured** in connection with any **Claim**.

### III. EXCLUSIONS

This **Policy** does not cover any **Claims** arising out of, based upon, involving directly or indirectly, resulting from or with respect to:

#### A. ACTS OF WAR

The consequence of war, invasion, hostilities (whether war be declared or not), civil war, rebellion, revolution, insurrection or military or usurped power, strike, riot or civil commotion.

#### B. ASBESTOS

COVERAGE B only, the existence, use, sale or clean up of, exposure to or testing for asbestos products, fibers, asbestos dust or asbestos containing products or materials unless specifically endorsed onto this **Policy**. This exclusion does not apply to **Claims** for **Bodily Injury** or **Property Damage**; or **Environmental Damage** for the remediation of naturally occurring asbestos in soil, sediment, groundwater and surface water.

This exclusion shall not apply to **Cleanup Costs** solely incurred for the remediation of asbestos containing material which has been inadvertently impacted (not including any displacement associated with activities including renovation, demolition or abatement) by an accident at a **Scheduled Location** or **Ancillary Location** which commences, in its entirety, during the **Policy Period** and demonstrable by the **Insured**. There shall be no coverage for any costs incurred to

remove, abate, monitor, repair or otherwise address asbestos products, fibers, asbestos dust or asbestos containing products or materials that have not been impacted by such accident.

C. COMPLIANCE ACTIONS AND IMPROVEMENTS

COVERAGE B only, funds spent for additions, equipment, upgrades or physical improvements to the **Scheduled Location** or **Ancillary Location** or other property of the **Insured** irrespective of whether actions or improvements were undertaken voluntarily, to assure future compliance with applicable laws, rules or regulations or for any other reason.

D. CONTRACTUAL LIABILITY

The liability of others assumed by an **Insured** under any contract or agreement unless:

1. The **Insured** would have such liability in the absence of a contract or agreement; or
2. The liability is assumed in a contract or agreement that is an **Insured Contract**, if such contract or agreement existed before the **Pollution Condition**, **Biological Agent Condition**, and/or **Wrongful Act** giving rise to such liability occurs.

E. FAULTY WORKMANSHIP/OWN WORK

Faulty construction workmanship (including approval thereof or any materials, parts, or equipment furnished in connection therewith) in any construction, erection, fabrication, installation, assembly, manufacture, or remediation performed by, on behalf of, or at the direction of any **Insured**, or any entity acting in the capacity of an agent, contractor, or subcontractor of any **Insured**.

This Exclusion shall not apply to:

1. a **Wrongful Act** committed by any **Insured**, subcontractor, or any other entity for whose acts an **Insured** is legally responsible; or
2. a **Pollution Condition** or **Biological Agent Condition** resulting from **Covered Operations**.

F. INSURED'S INTERNAL EXPENSES

Any costs, charges or expenses incurred by the **Insured** for goods supplied or services performed by any staff or salaried employees of the **Insured** or the **Insured's** parent, subsidiary or affiliate (whether or not an **Insured** under this **Policy**).

G. INSURED'S OWNED LOCATIONS

Any real property that is or was owned, leased, managed, or rented by (a) the **Insured**, (b) any person or organization with an ownership stake in or management control of the **Insured**, or (c) by any organization in which the **Insured** has an ownership stake or management control.

This exclusion shall not apply to:

1. COVERAGE B;
2. COVERAGE C or COVERAGE D with respect to any **Scheduled Location(s)** or **Ancillary Location(s)**; or
3. Property temporarily leased, rented or occupied for use in the performance of **Covered Operations**, including staging areas or storage of equipment or materials at or near a job site.

#### H. INSURED PRODUCT LIABILITY

Any goods or products designed, manufactured, sold, supplied, or distributed by an **Insured**, or others trading under an **Insured**'s name, including any, materials, parts, components or equipment furnished or installed by or on behalf of the Insured.

This exclusion does not apply to:

1. computer software sold or supplied by an **Insured** to its client solely in connection with the **Insured**'s rendering or failure to render **Professional Services**;
2. any goods or products installed in the course of **Covered Operations** that result in **Cleanup Costs, Bodily Injury or Property Damage**; or
3. goods or products installed in the course of **Covered Operations** that have been exclusively designed but not manufactured by or on behalf of the **Insured** for use in a specific project.

#### I. INSURED VERSUS INSURED

Any suit, action, demand, complaint or claim by any **Insured** against any other **Insured**.

This exclusion shall not apply to **Claims** brought by or against clients for whom the **Professional Services** or **Covered Operations** are or were performed

#### J. INTENTIONAL OR ILLEGAL ACTS

Any **Insured**'s:

1. Intentional, willful, deliberate non-compliance with any statute, regulation, ordinance, administrative complaint or notice of violation, notice letter, executive order or instruction of any governmental agency or body; or
2. Dishonest, illegal, fraudulent or criminal act.

This exclusion shall not apply to non-compliance based upon the **Insured**'s good faith reliance upon written advice of qualified counsel received in advance of such non-compliance or an **Insured**'s reasonable efforts to mitigate a **Wrongful Act(s), Pollution Condition(s) or Biological Agent Condition(s)** that necessitates immediate action, provided that such **Wrongful Act(s), Pollution Condition(s) or Biological Agent Condition(s)** is reported to the Company within fourteen (14) days of its commencement.

#### K. KNOWN CONDITIONS

Any:

1. **Claim** or circumstance reported under any prior policy or to another carrier;
2. **Pollution Condition(s) or Biological Agent Condition(s)**;
3. **Bodily Injury, Property Damage or Environmental Damage**; or
4. **Wrongful Act**;

that was known or discovered by a **Responsible Person** prior to the inception date of this **Policy** and not disclosed in the **Application** for this **Policy** or a prior policy, of which this **Policy** is a renewal, that was issued by the Company. This exclusion applies even if such **Pollution**

**Condition(s), Biological Agent Conditions(s), Bodily Injury, Property Damage, Environmental Damage, or Wrongful Act** or circumstance results in a new **Claim** during the **Policy Period** of this **Policy**.

L. LEAD-BASED PAINT

COVERAGE B only, the existence, required removal or abatement of lead paint. This exclusion does not apply to **Claims** for **Bodily Injury** or **Property Damage**.

This exclusion shall not apply to **Cleanup Costs** solely incurred for the remediation of lead-based paint which has been inadvertently impacted (not including any displacement associated with activities including renovation, demolition or abatement) by an accident at a **Scheduled Location** or **Ancillary Location** which commences, in its entirety, during the **Policy Period** and is demonstrable by the **Insured**. There shall be no coverage for any costs incurred to remove, abate, monitor, repair or otherwise address lead-based paint that has not been impacted by such accident.

M. PROPERTY DAMAGE TO COVERED OPERATIONS AND PRODUCTS

Any **Property Damage** to:

1. That particular part of real property on which **Covered Operations** are being performed, if the **Property Damage** is caused by such **Covered Operations**;
2. That particular part of property or real property that has been constructed, furnished or serviced as part of **Covered Operations**; or
3. The **Insured Product**, if the **Property Damage** arises from the **Insured Product** or any part of it.

Subparagraphs 1. and 2. do not apply to **Completed Operations**.

N. PROTECTIVE CLAIM

The amount of any default judgment, arbitration award or adjudicator's decision in circumstances where the **Design Professional** has failed to plead and/or provide a defense, response or answer, or take any other procedural step, except that this exclusion shall not apply to the amount of **Ultimate Loss** which the **Insured** would have been entitled to recover from the **Design Professional** had such defense, response or answer been pleaded and/or provided, or procedural step been taken.

In such instance where the **Design Professional** has failed to plead and/or provide a defense, response or answer, or take any other procedural step, the burden of proving the extent of **Ultimate Loss** which the **Insured** would have been entitled to recover from the **Design Professional** will be upon the **Insured**.

O. PROTECTIVE CLAIM LEGAL FEES

Attorney's fees and any other costs and expenses incurred by any **Insured** in connection with the making and prosecution of a **Protective Claim**.

P. PROTECTIVE LOSS CONSENT

Any settlement that has been reached with the **Design Professional** involving the limits of liability of this **Policy** without the express written consent of the Company, such consent not to be unreasonably withheld or delayed

Q. PUNITIVE OR EXEMPLARY DAMAGES

Punitive or exemplary damages, multiplied damages, assessments, fines or penalties (including those arising from criminal actions), except where the law permits insurance to pay such damages and fines.

R. SEPARATELY INSURED PROJECTS

Any project that is insured under a project specific professional and/or pollution insurance policy, provided, however, that this exclusion shall not apply where the **Insured's** liability is found to be in excess of the limit of liability available under such project specific professional and/or pollution insurance policy as applicable.

S. UNDERGROUND STORAGE TANKS

COVERAGE B only, the existence of any underground storage tank(s), the contents within any underground storage tank(s) and associated underground piping at a **Scheduled Location** or **Ancillary Location**.

This exclusion does not apply to **Scheduled Locations** with respect to:

1. Unknown underground storage tank(s), the contents within any underground storage tank(s) and associated underground piping that the **Insured** had discovered after the inception date of this **Policy**;
2. Underground storage tank(s) that are endorsed onto this **Policy**;
3. Any underground storage tank(s) that have been closed or abandoned in place in accordance with all applicable **Environmental Laws**; or
4. Storage tank(s) located within an accessible subsurface underground vault that can be visually inspected in its entirety.

T. WASTE FACILITIES

Any waste or other kind of products or materials transported, shipped or delivered via any automobile, aircraft, watercraft, or rolling stock to any transfer, storage or disposal facility beyond the boundaries of a location at which **Covered Operations** are being performed.

This exclusion shall not apply to:

1. COVERAGE C; or
2. **Transportation** to which this **Policy** applies.

U. WORKERS COMPENSATION AND EMPLOYERS LIABILITY

1. Any obligation of any **Insured** under workers compensation, disability benefits, unemployment compensation, employee benefits, pension sharing, ERISA law or any similar law; or



2. Any actual or alleged refusal to employ, termination of employment, harassment, humiliation or discrimination on any basis, or other employment related practices or policies. This exclusion applies whether the **Insured** may be held liable as an employer or in any other capacity.

#### IV. LIMITS OF INSURANCE

The limits of this insurance are presented in the following sections regarding “Maximum Aggregate Limit” and separate limits of liability.

##### A. MAXIMUM AGGREGATE LIMIT

The Company’s total liability hereunder for all **Bodily Injury, Property Damage, Cleanup Costs, Damages, Environmental Damage, Ultimate Loss, Mitigation Costs, Public Relations Expenses and Defense Expenses** or any other amounts under this **Policy**, including any coverages added by endorsement (unless otherwise indicated), shall not exceed the “Maximum Aggregate Limit” specified in the Declarations irrespective of any of the following:

1. The number of **Claims** made;
2. The number of persons or organizations making **Claims**;
3. The number of persons or organizations covered hereunder;
4. The number of actual or alleged **Pollution Condition(s), Biological Agent Condition(s), or Wrongful Acts**; or
5. The number of times **Cleanup Costs, Public Relations Expenses, Bodily Injury, Property Damage, Environmental Damage, Ultimate Loss, Damages, Mitigation Costs** are incurred.

##### B. LIMITS OF LIABILITY

Subject to the Maximum Aggregate Limit above:

1. The “Coverage A – Covered Operations”, amounts shown in the Declarations is the maximum amount the Company will pay under COVERAGE A of this **Policy** for any **Claim(s)** resulting from the same or related **Pollution Condition(s)** or **Biological Agent Condition(s)**, whichever applies.
2. The “Coverage B – Insured’s Locations” and “Coverage C – Non-owned Disposal Sites” amounts shown in the Declarations are the maximum amounts the Company will pay under COVERAGES B and C, respectively, of this **Policy** for any **Claim(s)** resulting from the same or related **Pollution Condition(s)**.
3. The “Coverage D – Public Relation Expenses” amount shown in the Declarations is the maximum amount the Company will pay for **Public Relations Expenses** under COVERAGE D of this **Policy** for any **Claim(s)** resulting from the same or related **Wrongful Acts, Pollution Condition(s)** or **Biological Agent Condition(s)**, whichever applies.
4. The “Coverage E – Professional Liability” and “Coverage F – Protective Professional Liability” amounts shown in the Declarations are the maximum amounts the Company will pay under COVERAGES E and F of this **Policy** for any **Claim(s)** resulting from the same or related **Wrongful Act(s)**, whichever applies.

5. The “Coverage G – Mitigation of Loss” amount shown in the Declarations is the maximum amount the Company will pay under COVERAGE G of this **Policy** for any **Mitigation Costs** resulting from the same or related **Wrongful Act(s), Pollution Condition(s) or Biological Agent Condition(s)**.
6. If more than one coverage applies to the same **Claim**, the Company’s maximum limit of liability for that **Claim** under all those coverages shall not exceed the single highest coverage limit of liability applicable to such **Claim**.
7. The “Maximum Aggregate Limit” amount shown in the Declarations is the maximum amount the Company will pay under this **Policy**.

The Limits of Insurance shown in the Declarations shall apply in excess of the Self-Insured Retention amount shown in the Declarations.

The single Limit of Liability applies if the same **Wrongful Act(s), Pollution Condition(s) or Biological Agent Condition(s)** or series of related **Wrongful Act(s), Pollution Condition(s) or Biological Agent Condition(s)**, whichever applies, takes place over two or more **Policy Periods**. Related **Wrongful Acts(s), Pollution Condition(s) or Biological Agent Condition(s)** are those **Wrongful Act(s), Pollution Condition(s) or Biological Agent Condition(s)**, respectively, that arise out of, are based on, relate to, or are in consequence of, the same or related or series of related facts, events, circumstances or situations.

- C. If a Separate Defense Expenses Limit amount is shown in the Declarations, then **Defense Expenses** shall not be included within or reduce the Limits of Liability described in A. and B. above, until **Defense Expenses** in the aggregate paid by the Company for all **Claims** under the **Policy** equal the amount designated in the Declarations. Once payment of **Defense Expenses** under the **Policy** equals the amount shown in the Declarations, **Defense Expenses** shall be included within and reduce the Limits of Liability described in A. and B. above.

#### D. SUPPLEMENTARY PAYMENTS

1. The Company will reimburse the **Insured** up to \$500 for loss of earnings to each **Insured** for each day, or part of a day, such **Insured** is in attendance, at the request of the Company, defense counsel, or as required by law, at a trial, hearing, or arbitration proceeding involving a covered **Claim**. The maximum amount payable by the Company hereunder for all such amounts shall not exceed \$5,000 regardless of the number of **Insureds**, the number of days or partial days the **Insured** is in attendance, the number of trials, hearings, or arbitration proceedings the **Insured** is required to attend, or the number of **Claims** resulting in such payments.
2. The Company will reimburse the **Insured** up to \$10,000 for reasonable attorneys’ fees, costs, and expenses incurred in connection with the investigation or defense of each **Disciplinary Proceeding**, where notice of such **Disciplinary Proceeding** is both first received by the **Insured** and reported in writing to the Company during the **Policy Period**, the Automatic Extended Reporting Period, or the Optional Extended Reporting Period, if any, and such **Disciplinary Proceeding** arises from an actual or alleged **Wrongful Act, Pollution Condition or Biological Agent Condition**. The maximum amount payable by the Company hereunder for all such amounts shall not exceed \$100,000 regardless of the number of **Insureds** or the number

of **Disciplinary Proceedings**. The Company shall not be obligated to defend any **Disciplinary Proceeding**, or pay any fine, penalty, or award resulting from any **Disciplinary Proceeding**.

3. The Company will reimburse the **Insured** for reasonable attorneys' fees, costs, and expenses incurred in connection with responding to any governmental investigation, action, or proceeding commenced against any **Insured** and reported in writing to the Company during the **Policy Period**, the Automatic Extended Reporting Period, or the Optional Extended Reporting Period, if any, pursuant to the Americans with Disabilities Act of 1990 (ADA), the federal Fair Housing Act (FHA), or the Occupational Safety and Health Act (OSHA), and arising from a **Wrongful Act**. The maximum amount payable by the Company hereunder for all such amounts shall not exceed \$10,000 each **Claim** / \$100,000 in the Aggregate, regardless of the number of **Insureds** or the number of ADA, FHA, or OSHA related governmental investigations, actions, or proceedings.
4. Upon written request by the **Insured** during the **Policy Period**, the Automatic Extended Reporting Period, or the Optional Extended Reporting Period, if any, the Company will retain and pay up to \$10,000 each **Claim** for reasonable attorneys' fees and costs to advise and/or represent the **Insured** regarding the production of documents and/or during the preparation and giving of testimony, in response to a subpoena served on the **Insured**, arising from a **Wrongful Act, Pollution Condition or Biological Agent Condition**. The maximum amount payable by the Company hereunder for all such amounts shall not exceed \$100,000 in the Aggregate, regardless of the number of **Insureds** or the number of subpoenas.
5. The Company will reimburse the **Insured** for the reasonable and necessary additional expense payable to a third party software consulting company that are not otherwise recoverable from any warranty or guarantee, arising from loss of or damage to information due to a malfunction of software used in connection with a Building Information Modeling (BIM) system purchased from a third-party vendor that was not modified by the **Insured** or on the **Insured's** behalf, including erroneous calculations or modeling, provided that the malfunction is first discovered during the **Policy Period** and after the system has been put to its intended use in the course of construction in support of **Professional Services** and is reported to the Company, in writing, by the **Insured**, during the **Policy Period**, within ninety (90) days of the end of the **Policy Period**, the Automatic Extended Reporting Period, or the Optional Extended Reporting Period, if any. The maximum amount payable by the Company hereunder for all such amounts shall not exceed \$25,000 regardless of the number of consulting companies, systems purchased or malfunctions.
6. The Company will reimburse the **Insured** for any reasonable and necessary expenses incurred by the **Insured** in the use of **Green Building Materials**, even when the use of such materials is not necessary, as part of **Cleanup Costs** when otherwise covered under this **Policy**. The maximum amount payable by the Company hereunder for all such amounts shall not exceed \$250,000 regardless of the number of **Pollution Conditions** or **Biological Agent Conditions**.

Supplementary Payments are not subject to a Self-Insured Retention and shall not reduce the Limits of Liability. The Company's consent is required prior to incurring any Supplementary Payments described in Paragraphs 1.-6. above, and the Company shall not be liable for any Supplementary Payment to which it has not consented.

#### E. MULTIPLE INSURED, CLAIMS, AND CLAIMANTS

The inclusion herein of more than one **Insured** shall not operate to increase the Company's Limits of Liability, including any Sublimits. **Claims** based upon, arising out of, or attributable to the actual or alleged same **Wrongful Act, Pollution Conditions or Biological Agent Conditions, or Wrongful Acts, Pollution Conditions or Biological Agent Conditions** that are **Interrelated** shall be treated as a single **Claim**, regardless of whether made against one or more than one **Insured**. All such **Claims**, whenever made, shall be considered first made when the earliest related **Claim** was first made, whether before or during the **Policy Period**, and all such **Claims** shall be subject to the Limits of Liability, any applicable Sublimit, and the Self-Insured Retention as set forth in the Declarations.

#### V. SELF-INSURED RETENTION

The Company's obligation for **Bodily Injury, Property Damage, Cleanup Costs, Damages, Ultimate Loss, Mitigation Costs, Public Relations Expenses, Environmental Damage and Defense Expenses** shall only be in excess of the applicable Self-Insured Retention as specified in the Declarations for the same or related **Wrongful Act(s), Pollution Condition(s) or Biological Agent Condition(s)**. The Self-Insured Retention shall be applied as shown in the Declarations.

Payment of the Self-Insured Retention is a condition precedent to coverage and must be paid by the **First Named Insured** and is not insured by the Company. Further, the **First Named Insured** must remain wholly liable for the Self-Insured Retention and cannot insure any amounts within the Self-Insured Retention. Other insurance will not be applied to reduce the Self-Insured Retention under this **Policy**. The **First Named Insured** shall reimburse the Company for advancing any element of **Bodily Injury, Property Damage, Cleanup Costs, Damages, Ultimate Loss, Mitigation Cost, Public Relations Expenses, Environmental Damage or Defense Expenses** falling within the Self-Insured Retention within thirty (30) days of the Company's advancement of any amounts within the Self-Insured Retention.

#### VI. EXTENDED REPORTING PERIOD

THE PROVISIONS IN THIS SECTION OF THIS CONTRACT APPLY ONLY TO CLAIMS-MADE COVERAGES

The following section describes the automatic and optional extended reporting period provisions of this **Policy**. The Extended Reporting Period provisions provided by this section shall apply only to coverages that are indicated as applying on a Claims-made basis, and shall under no circumstance extend the **Policy Period**, change the scope of coverage, broaden or extend the reporting requirements applicable to **Ancillary Location(s)** or increase any Aggregate Limits of Insurance shown in the Declarations.

##### A. AUTOMATIC EXTENDED REPORTING PERIOD

The **Insured** is entitled to a sixty (60) day Automatic Extended Reporting Period for no additional premium upon cancellation or non-renewal of this **Policy** in accordance with the terms and conditions of this section. The Automatic Extended Reporting Period shall apply to **Claims** first made and reported to the Company within the Automatic Extended Reporting Period, but:

1. For **Professional Services** only with respect to **Professional Services** performed prior to the end of the **Policy Period** and on or after the **Retroactive Date**; and

2. For **Scheduled Location(s)** or **Ancillary Location(s)**, only with respect to **Pollution Condition(s)** or **Biological Agent Condition(s)** that (a) are discovered during the **Policy Period** and reported during the Automatic Extended Reporting Period, and (b) commenced on or after the applicable **Retroactive Date**, if any, and before the **Policy** terminates.

The **Insured** shall not have the right to the Automatic Extended Reporting Period if:

1. The **Policy** was cancelled due to non-payment of premium, fraud or material misrepresentation; or
2. The **Insured** purchases other insurance to replace this **Policy**.

#### B. OPTIONAL EXTENDED REPORTING PERIOD

The **First Named Insured** may purchase an Optional Extended Reporting Period upon cancellation or non-renewal of the **Policy** subject to the following terms and conditions:

1. The **First Named Insured** makes a written request for an Optional Extended Reporting Period that the Company receives within thirty (30) days of the **Termination Date**; and
2. The **First Named Insured** pays the Company an additional premium (to be determined by the Company) within thirty (30) days of the **Termination Date**. Such additional premium charge may not exceed 200% of the **Policy** premium stated in the Declarations.

The maximum Optional Extended Reporting Period may at the election of the **First Named Insured** be for a period of up to thirty-six (36) months from the **Termination Date**. The Optional Extended Reporting Period shall apply to **Claims** first made against the **Insured** and reported to the Company within the Optional Extended Reporting Period, but:

- a. For **Professional Services** only with respect to **Professional Services** performed prior to the end of the **Policy Period** and on or after the **Retroactive Date**; and
- b. For **Scheduled Location(s)** or **Ancillary Location(s)**, only with respect to **Pollution Condition(s)** or **Biological Agent Condition(s)** that (a) are **Discovered** and reported during the Optional Extended Reporting Period, and (b) commenced on or after the applicable **Retroactive Date**, if any, and before the **Policy** terminates.

The **First Named Insured** shall not have the option to purchase the Optional Extended Reporting Period if:

- a. The **Policy** was cancelled due to non-payment of premium, fraud or material misrepresentation; or
- b. The **First Named Insured** purchases other insurance to replace this **Policy**.

In the event that the Optional Extended Reporting Period is purchased by the **First Named Insured**, the Optional Extended Reporting Period shall run concurrent to the Automatic Extended Reporting Period and shall not be in addition to the Automatic Extended Reporting Period. Once purchased, the Optional Extended Reporting Period is non-cancellable and will only be effective if the premium is paid when due.

## VII. CONDITIONS

### A. ASSIGNMENT

This **Policy** may be assigned only with the prior written consent of the Company. Such written consent shall not be unreasonably withheld or delayed by the Company.

#### B. BANKRUPTCY

Bankruptcy or insolvency of the **Insured** or of the **Insured's** estate will not relieve the Company of its obligations under this **Policy**.

#### C. CANCELLATION

1. The **First Named Insured** may cancel this **Policy** by mailing to the Company written notice stating when thereafter such cancellation shall become effective. The **Termination Date** shall be the date stated in such written notice.

The Company may cancel this **Policy** for:

- a. Fraud or material misrepresentation by an **Insured**;
- b. Any **Insured's** failure to comply with the terms and conditions under this **Policy**;
- c. Material change in the nature or extent of the risk involved hereunder; or
- d. Failure to pay premium.

In the event of cancellation for any reason other than failure to pay premium, the Company shall provide written notice stating when not less than thirty (30) days thereafter such cancellation shall become effective. In the event the **First Named Insured** fails to pay premium under this **Policy**, the Company shall provide not less than fifteen (15) days written notice of cancellation of the **Policy**. The **Termination Date** shall be the date stated in any such written notice.

However, with respect to b. or d. above, the **Insured** shall have the ability, within such thirty (30) day time period with respect to b. or such fifteen (15) day time period with respect to d., to cure such failure. The Company shall have the right, in its sole discretion, to determine whether or not such a failure has been cured.

The mailing of notice to the last known address of the **First Named Insured** in the manner provided herein or hand delivery to such address shall be sufficient proof of notice.

2. In the event of cancellation by the **First Named Insured**, the earned premium shall be computed in accordance with the customary short rate table after applying the minimum earned premium percentage or amount, as applicable, set forth in the Declarations, provided that, the minimum earned premium amount shall be 100% in the event a **Claim** has been made under this **Policy**. In the event of cancellation by the Company, the earned premium shall be computed pro rata and the Company will tender any return premium subject to retaining a minimum earned premium equal to 25% of the amount specified in the Declarations, provided that, the minimum earned premium amount shall be 100% in the event a **Claim** has been made under this **Policy**. Premium adjustment may be made either at the time cancellation is effective or as soon as practicable thereafter, but neither tender of the unearned premium nor return of this **Policy** shall be a condition to cancellation hereunder.

#### D. CHANGES

No provision of this **Policy** may be amended, waived or otherwise changed except by endorsement hereto and the written agreement of the **First Named Insured** and the Company.

E. CONCEALMENT OR FRAUD

If the **Insured** wilfully concealed or misrepresented any fact or circumstance material to the granting of coverage under this **Policy**, this entire **Policy** shall be voidable by the Company.

F. ECONOMIC OR TRADE SANCTIONS

If coverage for a **Claim** or suit under this **Policy** is in violation of any United States of America economic or trade sanctions, including but not limited to, sanctions administered and enforced by the United States Treasury Department's Office of Foreign Assets Control ("OFAC"), then coverage for that **Claim** or suit shall be null and void.

G. ENFORCEABILITY

If any part of this **Policy** is deemed invalid or unenforceable, it shall not affect the validity or enforceability of any other part of this **Policy**, which shall be enforced to the full extent permitted by law.

H. FIRST NAMED INSURED AS AGENT

The **First Named Insured** is responsible for payment of all premiums, retentions and deductibles, and will act as the sole agent on behalf of all **Insureds** with respect to all matters involving this **Policy** unless any such responsibilities are otherwise designated by endorsement.

I. HEADINGS

The descriptions in the headings of this **Policy** are solely for convenience and form no part of the **Policy** terms and conditions.

J. INSPECTION AND AUDIT

The Company has the right, upon reasonable advance notice, to inspect the **Insured's** property or operations at any time. The Company may examine an audit the **Insured's** books and records as they relate to this **Policy** at any time during the **Policy Period** and up to three (3) years afterward. Neither the Company's right to inspect the **Insured's** property or operations, any actual inspection performed pursuant to this right, nor any report resulting from any inspection shall constitute an undertaking, on behalf of the **Insured** or any other party, to determine or warrant that the property or operations are safe, healthful, conform to acceptable engineering practice or are in compliance with any law, rule or regulation. The **Insured** will provide appropriate assistance and cooperation to the Company during any inspection.

K. NO ACTION AGAINST COMPANY

No right of action brought by any person or organization, other than an **Insured**, shall lie against the Company unless, as a condition precedent thereto:

1. Each **Insured** has fully complied with all the provisions of the **Policy**; and
2. The amount of the **Insured's** obligation to pay has been finally determined either by:
  - a. Written agreement of the **Insured**, the Company and the party asserting the **Claim**; or

- b. By final judgment against the **Insured** after actual trial of the issues and the period of time to appeal has elapsed without an appeal having been taken or, if an appeal has been taken, until after such appeal has been adjudicated.

No person or organization shall have any right under this **Policy** to join the Company as a party to any action against the **Insured** to determine the **Insured**'s liability nor shall the Company be impleaded by the **Insured** or its legal representative.

#### L. NOTICE OF CONDITIONS AND CLAIMS

The **First Named Insured** shall as soon as practicable provide written notice of any **Wrongful Act(s)**, **Pollution Condition(s)**, or **Biological Agent Condition(s)** discovered, or **Claim** received. Such written notice:

1. Shall be given to the Company; and
2. Shall contain complete details regarding the **Wrongful Act(s)**, **Pollution Condition(s)** or **Biological Agent Condition(s)**, or **Claim**, including, but not limited to:
  - a. The exact date the **Wrongful Act(s)**, **Pollution Condition(s)** or **Biological Agent Condition(s)** was Discovered or the **Claim** was made, its nature and location, and circumstances giving rise to such **Claim** or discovery;
  - b. All information relating to the cause of the **Wrongful Act(s)**, **Pollution Condition(s)** or **Biological Agent Condition(s)**, including, the **Bodily Injury**, **Property Damage**, **Cleanup Costs**, or **Damages** that have resulted or may result from such **Wrongful Act(s)**, **Pollution Condition(s)** or **Biological Agent Condition(s)**, all engineering information available on the **Wrongful Act(s)**, **Pollution Condition(s)** or **Biological Agent Condition(s)**, and any other information that the Company deems reasonably necessary;
  - c. All demands, summonses, notices or other process or papers filed with a court of law, administrative agency or an investigative body;
  - d. The names and addresses of all parties asserting a **Claim** and all persons with knowledge of the **Claim** and **Wrongful Act(s)**, **Pollution Condition(s)** or **Biological Agent Condition(s)**; and
  - e. All other information in the possession of the **Insured** regarding the **Wrongful Act(s)**, **Pollution Condition(s)** or **Biological Agent Condition(s)**, the discovery and the **Claim**.

The duties of the **First Named Insured** hereunder may not be delegated. Nothing contained herein shall relieve the **First Named Insured** from any obligation, including any notification requirements it may have pursuant to applicable laws, rules or regulations.

Written notice shall be given whether or not the **First Named Insured** believes that a **Wrongful Act(s)**, **Pollution Condition(s)**, **Biological Agent Condition(s)** or **Claim** will result in a demand in excess of the Self-Insured Retention.

When a **Pollution Condition(s)**, **Biological Agent Condition(s)** or other circumstance requires an **Insured** to undertake **Emergency Mitigation Actions**, the **First Named Insured** must immediately provide written notice to the Company upon undertaking such



**Emergency Mitigation Actions**, but in no event later than seventy-two (72) hours after the **Pollution Condition(s)** or **Biological Agent Condition(s)** has been discovered.

M. NOTICE OF CIRCUMSTANCES

If during the **Policy Period** any **Insured** first becomes aware of any fact, circumstance, **Wrongful Act(s)**, **Pollution Condition(s)**, or **Biological Agent Condition(s)** which may reasonably be expected to give rise to a **Claim** that would be covered under this **Policy**, and provided that the **Insured** gives written notice to the Company of such fact, circumstance, **Wrongful Act(s)**, **Pollution Condition(s)**, or **Biological Agent Condition(s)** during the **Policy Period**, then any **Claim** that may subsequently be made against any **Insured** arising out of such fact, circumstance, **Wrongful Act(s)**, **Pollution Condition(s)**, or **Biological Agent Condition(s)** shall be deemed for purposes of this **Policy** to have been made during the **Policy Period**.

As a condition precedent to exercising its rights hereunder, the **Insured** shall include within any such notice a full description of the fact, circumstance, **Wrongful Act(s)**, **Pollution Condition(s)**, or **Biological Agent Condition(s)**, that is the subject of the notice, the nature or extent of the injury or potential damages, the names of the potential claimants, the manner in which the **Insured** first became aware of such fact, circumstance, **Wrongful Act(s)**, **Pollution Condition(s)**, **Biological Agent Condition(s)**, and give the Company any such additional information and cooperation as it may reasonably request.

N. OTHER INSURANCE

This **Policy** shall be in excess of the amount of the applicable Self-Insured Retention of this **Policy** and excess of any other insurance or indemnification available to the **Insured**, whether such insurance or indemnification is collectible or uncollectible, and whether such insurance is stated to be primary, pro rata, contributory, excess, contingent, or otherwise, unless such other insurance is written only as specific excess insurance over the Limits of Liability provided in this **Policy**. However, under Coverage A, when the **Insured** is required by contract, agreement or permit to include any person or entity as an additional insured, such coverage shall be provided on a primary and non-contributory basis.

O. REPRESENTATIONS AND COVENANTS

The **First Named Insured** acknowledges and agrees that:

1. The information, warranties and representations contained in the **Application** submitted by the **Insured** as well as in all supplemental documents provided herewith are true, correct and complete;
2. The Company has issued this **Policy** in specific reliance upon the truth and accuracy of the warranties and representations contained in the **Application**; and
3. All activities of the **Insured** have been and will be conducted in full compliance with **Environmental Laws**.

The **Application**, the Declarations and endorsements, if any, are incorporated into, and are part of, this **Policy** and embody all agreements existing between the **First Named Insured** and the Company and supersede all prior agreements, whether written or oral, expressed or implied.

P. SEPARATION OF INSURED

Except with respect to the Limits of Liability, the Insured versus Insured exclusion and the Known Conditions exclusion under the Exclusions section, and any rights or duties specifically assigned to the **Insured**, this **Policy** applies:

1. As if each **Insured** were the only **Insured**; and
2. Separately to each **Insured** against whom a **Claim** is made.

In the event of any misrepresentation, concealment, breach of condition or violation of any obligation under this **Policy** by any one **Insured**, such misrepresentation, concealment, breach of condition or violation of any obligation will not prejudice any other **Insured** that did not participate or assist in, or have knowledge of, such misrepresentation, concealment, breach of condition or violation of any obligation unless the **Insured** that misrepresented, concealed or breached a term or condition of or violated an obligation under this **Policy** is a parent, subsidiary or affiliate of the **Insured**.

Q. SUBROGATION

In the event that the Company pays any amount under this **Policy**, the Company shall be subrogated to all of each **Insured's** rights of recovery against any person or organization. All **Insureds** shall execute and deliver instruments and papers and do whatever else is necessary to secure such rights. No **Insured** shall do anything to waive or prejudice such rights. Any recovery obtained through subrogation, after expenses incurred in such subrogation are deducted by the Company, shall be applied first to the **Insured** to the extent of any payments in excess of the Limits of Liability under this **Policy**, if any, then to the Company to the extent of its payment under the **Policy**, and then to the **Insured** to the extent of any retention or deductible. However, if the **Insured** has, prior to the time the **Wrongful Act(s), Pollution Condition(s), Biological Agent Condition(s)** is discovered or the **Damages, Bodily Injury, Property Damage or Cleanup Costs** to which this **Policy** applies takes place, waived subrogation rights against a person or organization in a written contract or agreement, the Company hereby waives any rights of recovery against such person or organization, provided that such person or organization is not a subcontractor of the **Insured**.

R. TERRITORY

This **Policy** only applies to a **Claim** first brought within the United States of America, its territories or possessions, or Canada.

S. TRANSFER OF YOUR RIGHTS AND DUTIES UNDER THIS POLICY

Any rights and duties under this **Policy** may not be transferred without the Company's prior written consent except in the case of death of an individual **Insured**. If an individual **Insured** dies, the rights and duties will be transferred to the individual **Insured's** legal representative but only while acting within the scope of duties as the individual **Insured's** legal representative. Until the individual **Insured's** legal representative is appointed, anyone having proper temporary custody of the individual **Insured's** property will have the individual **Insured's** rights and duties but only with respect to that property.

VIII. DEFINITIONS

Words and phrases in bold in this **Policy** have the following special meaning:

1. **Ancillary Location** means:

- a. Any location(s) designated on a Scheduled Ancillary Location(s) Endorsement; or
- b. Any real property owned, occupied, rented or leased by the **First Named Insured** designated in the Declarations and utilized exclusively as office, warehouse, or vehicle and equipment parking or storage, or a combination thereof, provided that, such location(s) is utilized by the **First Named Insured** for activities or materials that directly support **Covered Operations**. **Ancillary Location** shall not include any property that is leased or rented to third parties for profit.

2. **Application** means all **Applications**, including attachments, and all other materials and information provided by the **Insured** to the Company for the purposes of underwriting or issuing this **Policy** or any policy of which this **Policy** is a direct or indirect renewal or replacement.

3. **Biological Agents** means any legionella pneumophila, fungi including mold or mildew and any mycotoxins, spores, or byproducts produced or released by fungi.

4. **Biological Agent Condition(s)** means the presence of **Biological Agents**, which the **Insured** had not discovered prior to the inception of this **Policy**.

**Biological Agent Condition(s)** does not include **Pollution Condition(s)**.

5. **Bodily Injury** means, sickness, disease, mental anguish, emotional distress or physical injury sustained by any person, including death resulting therefrom. **Bodily Injury** shall also include medical monitoring costs.

6. **Cargo** means goods, products or wastes carried for delivery on or within: (a) an automobile, van, truck, trailer or semitrailer designed and registered to travel on public roads; or (b) an aircraft, rolling stock, or watercraft, by a carrier that is properly licensed to transport such goods, products or wastes.

7. **Claim(s)** means written notice:

- a. To an **Insured** seeking to hold any **Insured** responsible for **Cleanup Costs**, **Environmental Damage**, **Bodily Injury**, **Property Damage**, or **Damages**; and
- b. By the **Insured** seeking coverage for **Cleanup Costs** or **Public Relations Expenses** resulting from **Pollution Condition(s)** or **Biological Agent Condition(s)**.

8. **Cleanup Costs** means the reasonable and necessary costs incurred to investigate, test, sample, monitor, remove, remediate, dispose, treat, neutralize, or immobilize **Pollution Condition(s)** or **Biological Agent(s)** to the extent required by **Environmental Law** in the jurisdiction of such **Pollution Condition(s)** or **Biological Agent(s)**.

**Cleanup Costs** shall also include actions undertaken to repair, replace or restore tangible property to substantially the same condition such tangible property was in prior to being damaged during work performed in the course of incurring **Cleanup Costs**.

9. **Completed Operations** means **Covered Operations** that have been completed. For the purposes of determining when work has been completed, **Covered Operations** shall be deemed completed at the earliest of the following times:
- a. When all of the work called for in the **Insured's** contract has been completed;
  - b. When all of the work to be done at the job site has been completed if the **Insured's** contract calls for work at more than one job site; or
  - c. When that part of the work done at a job site has been put to its intended use by any person or organization other than another contractor or subcontractor working on the same project.

Work that may need service, maintenance, correction, repair or replacement, but which is otherwise complete, will be treated as completed.

10. **Covered Operations** means activities performed for third parties, by or on behalf of the **Insured**, and includes **Completed Operations** associated with such activities.

**Covered Operations** includes:

- a. **Transportation**, whether conducted for the movement of the **Insured's** own materials and equipment or provided as a service to third parties; and
  - b. Ancillary activities performed by the **Insured** for itself that are necessary for the performance of **Covered Operations** but not directly performed for third parties, including but not limited to temporary use of storage areas, job site preparation, or mobilization of equipment and materials.
11. **Damages** means those amounts an **Insured** is legally obligated to pay on account of a **Wrongful Act**.
12. **Defense Expenses** means the reasonable and necessary legal costs, charges and expenses incurred by the Company, fees and expenses of any third-party administrator for the Company or, with the prior written approval of the Company, by an **Insured**, in the investigation, adjustment or defense of **Claims**. **Defense Expenses** do not include salary charges of regular employees or officials of the Company, fees and expenses of supervisory counsel retained by the Company, or the time and expense incurred by the **Insured** in assisting in the investigation of or resolving a **Claim** or in connection with **Cleanup Costs**, including, but not limited to, the cost of the **Insured's** in-house counsel, unless otherwise indicated.
13. **Design Professional** means those qualified persons or entities under written contract with an **Insured** to perform **Professional Services**.
14. **Design Professionals Insurance** means all available professional liability insurance policies, whether designated as primary or excess, where the **Design Professional** is an insured, including any professional liability insurance issued to design sub consultants.
15. **Disciplinary Proceeding** means any proceeding by an administrative, regulatory, or disciplinary official, board, or agency, to investigate charges or allegations of professional misconduct in the performance of or failure to perform **Professional Services**, including an initial inquiry before a state or federal licensing board or peer review committee. However, **Disciplinary Proceeding** shall not include a criminal proceeding or an Organizational Peer Review.

16. **Emergency Mitigation Action** means action that is necessary to clean up a **Pollution Condition** or **Biological Agent Condition** has been discovered that presents an immediate, dangerous and significant threat to human health or the environment where any delay by the **Insured** would cause further injury to persons or damage to property or increase significantly the cost of responding to a potential **Claim**. Prior written approval from the Company is required after expiration of the 72 hour period before the **Insured** may incur any additional **Cleanup Costs** or other costs or expenses to which this **Policy** would otherwise apply.
17. **Environmental Damage** means physical damage to the environment, including but not limited to surface water, groundwater, soil, flora, or fauna, that results in **Cleanup Costs** being required. With respect to **Biological Agents**, **Environmental Damage** includes physical damage to buildings or structures, or systems within such buildings or structures, that results in **Cleanup Costs** being required. **Environmental Damage** shall not include **Property Damage**.
18. **Environmental Laws** means any federal, state, provincial, foreign or local laws (including, but not limited to, statutes, rules, regulations, ordinances, guidance documents, and governmental, judicial or administrative orders and directives) that are applicable to **Pollution Condition(s)** or **Biological Agent Condition(s)**.
19. **First Named Insured** means the person(s) or organization(s) described as the **First Named Insured** in the Declarations.
20. **Green Building Materials** means environmentally preferable, sustainable, and/or energy efficient building products or materials that are recognized by The Leadership in Energy and Environmental Design (LEED®), Green Globes Assessment and Rating System, International Green Construction Code or Energy Star.
21. **Insured** means:
  - a. The **First Named Insured**;
  - b. Any entity of which the **First Named Insured** owns, either legally or beneficially, more than a fifty percent (50%) interest on or before the inception date of this **Policy**;
  - c. Any present or former director, officer, manager, partner, principal, trustee, member, shareholder, employee, volunteer, **temporary worker or leased worker** of the **First Named Insured**, but only while acting within the scope of his/her duties as such;
  - d. Any **Insured** with regard to its participation in a legal entity or joint ventures, but only with respect to **Liabilities** arising out of **Professional Services** or **Covered Operations** performed by or on behalf of the **First Named Insured**; **Insured** does not include the legal entity or joint venture itself, except as respects liability assumed by the **First Named Insured** for a **Pollution Condition** or **Biological Agent Condition**;
  - e. With regard to Coverage A – COVERED OPERATIONS only, any client of the **First Named Insured** or entity or person that requires the **First Named Insured** in a written contract, agreement, or permit to add such person or organization to this **Policy** as an “Additional Insured”, but only to the extent required and up to the limits required in such written contract or agreement;

- f. The estate, heirs, executors, administrators, and legal representatives of each **Insured** in the event of death, incapacity or bankruptcy, but only with respect to the liability of each **Insured** as otherwise covered by this **Policy**;
- g. Any other person or organization listed as an **Insured** by endorsement to this **Policy**;
- h. Any organization newly formed or acquired by the **First Named Insured** during the **Policy Period** and in which, thereafter, the **First Named Insured** has more than a fifty percent (50%) ownership interest. However, coverage for such organization(s) shall apply:
  - i. Only to **Professional Services** or **Covered Operations** performed on or after the date of formation or acquisition or exercised financial or management control; and
  - ii. Until the ninetieth (90<sup>th</sup>) day following the date of formation or acquisition or until the end of the **Policy Period**, whichever is earlier. After the ninetieth (90<sup>th</sup>) day, coverage shall only apply if such organization(s) has been endorsed to the **Policy** by the Company. Before doing so, the Company may, at its sole discretion, require additional information, including but not limited to a completed **Application**, loss history, or information regarding the operations of such organization(s), and may also require an additional premium.

22. **Insured Contract** means:

- a. With respect to any **Claim** arising from **Covered Operations** or **Professional Services**:
  - i. A contract or agreement with a client in which the **Insured** assumes liability for the operations of subcontractors for work performed on behalf of the **Insured** by such subcontractors;
  - ii. A sidetrack agreement;
  - iii. An obligation, as required by ordinance, to indemnify a municipality, except in connection with work for a municipality; or
  - iv. That part of any other contract or agreement pertaining to **Covered Operations** or **Professional Services** of the **Insured** (including an indemnification of a municipality in connection with work performed for a municipality) under which the **Insured** has assumed the tort liability of another party to pay for **Environmental Damage, Cleanup Costs, Bodily Injury, Property Damage** or **Damages** to a third party. Tort liability means a liability that would be imposed by law in the absence of any contract or agreement.
- b. With respect to any **Claim** arising from a **Scheduled Location** or **Ancillary Location**, a contract or agreement that is approved by the Company and scheduled by endorsement to the **Policy** as an **Insured Contract**.

23. **Insured Product** means:

- a. Any goods or products, other than real property, manufactured, sold, supplied, or distributed by the **Insured**, others trading under the **Insured**'s name or a person or organization whose business or assets the **Insured** has acquired; and
- b. Containers, materials, parts or equipment furnished in connection with such goods or products.

**Insured Product** includes warranties or representations made at any time with respect to the fitness, quality, durability, performance or use of an **Insured Product** and the providing of or failure to provide warnings or instructions.

**Insured Product** does not include waste sold or relinquished to a third party to be recycled or reused in lieu of disposal.

24. **Interrelated** means having as a common nexus any fact, circumstance, situation, event, transaction, or cause, or series of causally or logically connected facts, circumstances, situations, events, transactions, or causes.
25. **Mitigation Costs** mean those direct costs or expenses that are necessarily incurred, with the prior written consent of the Company, in order to mitigate or rectify **Wrongful Act(s)**, **Pollution Condition(s)**, or **Biological Agent Condition(s)** that would reasonably be expected to lead to a covered **Claim** under this Policy. **Mitigation Costs** do not include any costs or expenses that result in a betterment of the **Insured's** work.
26. **Natural Resource Damages** means physical injury to or destruction of, including the resulting loss of value of, land, fish, wildlife, biota, air, water, groundwater, drinking water supplies and other such resources belonging to, managed by, held in trust by, appertaining to, or otherwise controlled by the United States (including the resources of the fishery conservation zone established by the Magnuson-Stevens Fishery Conservation and Management Act (16 U.S.C. 1801 et seq.)), any state or local government, any foreign government, any Native American tribe or, if such resources are subject to a trust restriction on alienation, any member of a Native American tribe.
27. **Non-owned Disposal Site** means any treatment, storage or disposal facility used by an **Insured** provided that:
  - a. as of the date the waste or material is treated, stored or disposed of, the site is permitted or licensed by the applicable federal, state, local or provincial authorities to accept such waste or material,
  - b. as of the inception date of this **Policy** is not a Superfund Site or currently being investigated under the Comprehensive Environmental Response Compensation and Liability Act of 1980.

**Non-owned Disposal Site** does not include any treatment, storage or disposal facility that is owned, operated, managed leased or rented at any time by an **Insured** or any subsidiary or affiliate.
28. **Policy** means this document as well as the **Application**, all endorsements, the Declarations, modifications and addenda thereto.
29. **Policy Period** means the period set forth in the Declarations, any shorter period arising as a result of cancellation or any other period as changed by endorsement.
30. **Pollutant(s)** means any solid, liquid, gaseous or thermal irritant or contaminant, including smoke, vapor, soot, fumes, acids, alkalis, chemicals, toxic chemicals, liquids or gases, other irritants or contaminants or any discarded materials of any kind. **Pollutant(s)** includes electromagnetic fields, medical waste, and low level radiological material. **Pollutant(s)** also includes silt or sedimentation originating from a job site at which **Covered Operations** are being performed that has migrated off such job site.

**Pollutants** shall not include:

- a. "Source Material," "Special Nuclear Material" or "By-product Material" as such terms are defined in the Atomic Energy Act of 1954;
- b. Any materials described in a. above for which the **Insured** is protected under the Price Anderson Act, or under any indemnity from the United States Department of Energy or any governmental authority of the United States or any other nation; or
- c. **Biological Agents**.

31. **Pollution Condition(s)** means the discharge, dispersal, release or escape of **Pollutants**. **Pollution Condition(s)** includes the illicit abandonment of **Pollutants** at a **Scheduled Location, Ancillary Location** or job site at which **Covered Operations** are being performed, provided that such illicit abandonment was committed by a person or organization that is not an **Insured**, and without the knowledge of an **Insured**.

**Pollution Condition(s)** does not include a **Biological Agent Condition(s)**.

32. **Professional Services** means services performed for third parties, by or on behalf of the **Insured** as follows:

- a. only those services the **Insured** is qualified to perform for others in the **Insured's** capacity as an architect, engineer, land surveyor, landscape architect, construction manager, interior designer, environmental consultant, scientist, land planner, or space planner; or as an expert witness, technical consultant, or LEED Certification Consultant with respect to the foregoing listed services;
- b. construction management, program management, project management, owner's representation and any design delegated responsibility or design assist performed by the **Insured**, including but not limited to constructability reviews or value engineering;
- c. professional services with respect to any Building Information Modeling (BIM) systems, including but not limited to modification or alteration, transfer, protection, manipulation, use or misuse thereof; or
- d. ordinary technology services utilized in the performance of **Professional Services** described above. Such technology services include the design, development, programming, analysis, training, use, hosting, management, support and maintenance of any software, database, internet service, or website.

**Professional Services** do not include any activities in connection with construction means, methods or techniques; site safety; crane erection and use; scaffolding; or any temporary fencing or structures.

33. **Property Damage** means:

- a. Physical injury to or destruction of tangible property of persons or organizations other than the **Insured**, including the resulting loss of use and diminution in value thereof;
- b. Loss of use of tangible property of persons or organizations other than the **Insured** that has not been physically injured or destroyed, excluding any diminution in value of such property;



- c. **Natural Resource Damages**; or
- d. The diminution of value of tangible property of persons or organizations other than the **Insured** that is directly attributable to the effects of **Pollution Condition(s)** or **Biological Agent Condition(s)**;

but only to the extent the above injuries are not already remedied by **Cleanup Costs**. For purposes of determining the extent, if any, of diminution in value, the value of the tangible property injured shall equal the replacement cost of such property reduced by physical depreciation and obsolescence as of the time the damage to such tangible property was sustained.

**Property Damage** does not include **Cleanup Costs** and **Environmental Damage**.

For the purposes of this definition of **Property Damage** only, the definition of **Insured** shall not include:

- i. Clients for whom the **Covered Operations** are or were performed;
  - ii. Owners, financiers or lenders of a project at which **Covered Operations** are or were performed;
  - iii. Owners or managers of real property at which **Covered Operations** are or were performed;
  - iv. Owners of equipment or property leased, rented or borrowed by the **Named Insured** or by those performing **Covered Operations** on behalf of the **Named Insured**, but only with respect to **Covered Operations**; or
  - v. Persons or organizations added to the **Policy** as additional **Insureds** by endorsement.
34. **Protective Claim** means a written demand, demand for arbitration or mediation or a suit instituted by the **Insured** against the **Design Professional** seeking a remedy and alleging liability or responsibility on the part of such **Design Professional** arising from a **Wrongful Act(s)** in the performance or failure to perform **Professional Services**. **Protective Claim** does not include a demand or proceeding for non-monetary or injunctive relief.
35. **Public Relation Expenses** means reasonable and necessary expenses incurred by the **Insured**, and with the Company's prior written consent:
- a. After a newspaper or magazine publication or television news broadcast alleging responsibility on the part of an **Insured** for a **Wrongful Act(s)**, **Pollution Condition(s)** or **Biological Agent Condition(s)**;
  - b. For public relations or crisis management firms to restore public reputation and consumer confidence relating to the **Insured**;
  - c. At the request or recommendation of such public relations or crisis management firms, including any advertisement in any media if the Company provides its prior written consent to such advertisement; and
  - d. provided that such expenses are incurred within fourteen (14) days of the first such publication or broadcast and within thirty (30) days of the commencement of the **Wrongful Act(s)**, **Pollution Condition(s)** or **Biological Agent Condition(s)**.

36. **Responsible Person** means any officer, director, partner or other employee responsible for environmental affairs of the **Insured**.
37. **Retroactive Date** means:
- a. With respect to any **Covered Operations** or **Professional Services**, the date described as such and set forth in the Declarations or any applicable endorsement to the **Policy**, which is the earliest date that any **Covered Operations** or **Professional Services** can be performed for any coverage to be provided under this **Policy**; and
  - b. With respect to any **Scheduled Location(s)**, the date described as such and set forth in the Declarations, on a Scheduled Location(s) Endorsement, or any applicable endorsement to the **Policy**, which is the earliest date that a **Pollution Condition(s)** or **Biological Agent Condition(s)** can commence for any coverage to be provided under this **Policy**.
38. **Scheduled Location** means any location(s) designated on a Scheduled Location(s) Endorsement.
39. **Termination Date** means the effective date and hour of cancellation or expiration of this **Policy**.
40. **Transportation** means the movement of **Cargo** from its point of origin to the place of final delivery, including the loading or unloading of such **Cargo**. **Transportation** does not include (i) any movement within the legal boundaries of a **Scheduled Location, Ancillary Location** or **Non-owned Disposal Site**, or (ii) any intentional dispersal or release of **Cargo** from an aircraft.
41. **Ultimate Loss** means the amount the **Insured** is legally entitled to recover from each responsible **Design Professional** either by final adjudication by a court of competent jurisdiction, settlement, arbitration or any other method of dispute resolution to which the Company agrees in writing. Such **Ultimate Loss** must be the result of a **Wrongful Act(s)** of a **Design Professional**. In the event that multiple **Design Professionals** cause the same or related loss, the amount of **Ultimate Loss** shall not exceed the single loss caused by such multiple **Design Professionals**.
42. **Wrongful Act** means an actual or alleged negligent act, error or omission committed or attempted in the performance of, or failure to perform, **Professional Services**.



**Agenda Sheet for City Council:**

**Committee:** PIES **Date:** 10/21/2024

**Committee Agenda type:** Consent

**Date Rec'd** 10/22/2024

**Clerk's File #** OPR 2023-0851

**Cross Ref #**

**Project #** 2023043

**Council Meeting Date:** 11/04/2024

<b>Submitting Dept</b>	ENGINEERING SERVICES	<b>Bid #</b>	
------------------------	----------------------	--------------	--

<b>Contact Name/Phone</b>	DAN BULLER 509.625.6391	<b>Requisition #</b>	CR 26747
---------------------------	-------------------------	----------------------	----------

<b>Contact E-Mail</b>	DBULLER@SPOKANECITY.ORG		
-----------------------	-------------------------	--	--

<b>Agenda Item Type</b>	Contract Item		
-------------------------	---------------	--	--

<b>Council Sponsor(s)</b>	BWILKERSON JBINGLE KKLITZKE		
---------------------------	-----------------------------	--	--

<b>Agenda Item Name</b>	0370 - ADMINISTRATIVE RESERVE INCREASE 2023 RES CHIP SEAL SHAMROCK		
-------------------------	--	--	--

**Agenda Wording**

Administrative reserve increase for the contract with Shamrock Paving for 2023 Residential Chip Seal for a total increase of \$90,000.

**Summary (Background)**

Engineering Services is seeking authorization to add \$90,000 to the administrative reserve for the 2023 Residential Chip Seal project, which was completed this summer. The administrative reserve previously approved by council was approximately \$146,000 on the \$1.4 million project.

Lease? NO Grant related? NO Public Works? YES

**Fiscal Impact**

Approved in Current Year Budget? YES

Total Cost \$

Current Year Cost \$ 90,000

Subsequent Year(s) Cost \$

**Narrative**

**Amount**

**Budget Account**

Expense	\$ 90,000.00	# 1990 49893 42300 54201 21034
Select	\$	#
Select	\$	#
Select	\$	#
	\$	#
	\$	#



**Continuation of Wording, Summary, Approvals, and Distribution**

**Agenda Wording**

**Summary (Background)**

**Approvals**

<b><u>Dept Head</u></b>	BULLER, DAN
<b><u>Division Director</u></b>	FEIST, MARLENE
<b><u>Accounting Manager</u></b>	ORLOB, KIMBERLY
<b><u>Legal</u></b>	HARRINGTON,
<b><u>For the Mayor</u></b>	PICCOLO, MIKE

**Additional Approvals**

<b><u>PURCHASING</u></b>	NECHANICKY, JASON

**Distribution List**

	Tax&Licenses@spokanecity.org
jrhall@spokanecity.org	publicworksaccounting@spokanecity.org
eraea@spokanecity.org	dbuller@spokanecity.org
jradams@spokanecity.org	pyoung@spokanecity.org

## Committee Agenda Sheet

### Public Infrastructure, Environment & Sustainability Committee

<b>Committee Date</b>	10-21-24
<b>Submitting Department</b>	Engineering Services
<b>Contact Name</b>	Dan Buller
<b>Contact Email &amp; Phone</b>	<a href="mailto:dbuller@spokanecity.org">dbuller@spokanecity.org</a> , 625-6391
<b>Council Sponsor(s)</b>	Wilkerson, Bingle, Klitzke
<b>Select Agenda Item Type</b>	<input checked="" type="checkbox"/> Consent <input type="checkbox"/> Discussion    Time Requested:
<b>Agenda Item Name</b>	Cost Overrun on 2023 Residential Chipseal
<b>Proposed Council Action</b>	<input checked="" type="checkbox"/> Approval to proceed to Legislative Agenda <input type="checkbox"/> Information Only
<b>Summary (Background)</b>  *use the Fiscal Impact box below for relevant financial information	<ul style="list-style-type: none"> <li>Engineering Services is seeking authorization to add \$90,000 to the administrative reserve for the 2023 Residential Chip Seal project, which was completed this summer. The administrative reserve previously approved by council was approx. \$146,000 on the \$1.4 million project.</li> <li>This project experienced cost overruns, which exceeded the administrative reserve, and we are requesting additional spending authorization from City Council to cover those costs.</li> <li>To complete a quality chip seal project, crews must make sure that the street surface has been brought up to standard. That means, they perform crack sealing and pavement repair as needed. We put in cost items for this work based on historic averages. The streets in this round of work required substantially more crack sealing and pavement repair and patching than we typically see. This resulted in the need for extra funding.</li> <li>If approved by council, funds for this overage would come from the Transportation Benefit District (TBD).</li> <li>Despite this overrun, chip seal remains a very economical pavement repair treatment, costing much less per square yard than other pavement repairs like grind and overlay or complete rebuilds.</li> </ul>
<b>Fiscal Impact</b> <b>Approved in current year budget?</b> <input checked="" type="checkbox"/> Yes <input type="checkbox"/> No <input type="checkbox"/> N/A Total Cost: <u>\$90,000</u> Current year cost: \$90,000 Subsequent year(s) cost:	
<b>Narrative:</b> Please provide financial due diligence review, as applicable, such as number and type of positions, grant match requirements, summary type details (personnel, maintenance and supplies, capital, revenue), impact on rates, fees, or future shared revenue	
<b>Funding Source</b> <input checked="" type="checkbox"/> One-time <input type="checkbox"/> Recurring <input type="checkbox"/> N/A Specify funding source: Select Funding Source* Is this funding source sustainable for future years, months, etc? <a href="#">Click or tap here to enter text.</a>	
<b>Expense Occurrence</b> <input checked="" type="checkbox"/> One-time <input type="checkbox"/> Recurring <input type="checkbox"/> N/A  Other budget impacts: (revenue generating, match requirements, etc.)	

**Operations Impacts (If N/A, please give a brief description as to why)**

- What impacts would the proposal have on historically excluded communities?  
Public works services and projects are designed to serve all citizens and businesses. We strive to offer a consistent level of service to all, to distribute public investment throughout the community and to respond to gaps in services identified in various City plans.
- How will data be collected, analyzed, and reported concerning the effect of the program/policy by racial, ethnic, gender identity, national origin, income level, disability, sexual orientation, or other existing disparities?  
N/A
- How will data be collected regarding the effectiveness of this program, policy, or product to ensure it is the right solution?  
Public Works follows the City's established procurement and public works bidding regulations and policies to bring items forward, and then uses contract management best practices to ensure desired outcomes and regulatory compliance.
- Describe how this proposal aligns with current City Policies, including the Comprehensive Plan, Sustainability Action Plan, Capital Improvement Program, Neighborhood Master Plans, Council Resolutions, and others?  
This work is consistent with annual budget strategies to limit costs and approved projects in the 6-year CIP.

**Council Subcommittee Review**

- Please provide a summary of council subcommittee review. If not reviewed by a council subcommittee, please explain why not.

**Agenda Sheet for City Council:****Committee:** PIES **Date:** 10/21/2024**Committee Agenda type:** Consent**Date Rec'd**

10/22/2024

**Clerk's File #**

OPR 2024-0164

**Cross Ref #****Project #**

2021088

**Council Meeting Date:** 11/04/2024**Submitting Dept**

ENGINEERING SERVICES

**Bid #****Contact Name/Phone**

DAN BULLER 6391

**Requisition #**

CR 26789

**Contact E-Mail**

DBULLER@SPOKANECITY.ORG

**Agenda Item Type**

Contract Item

**Council Sponsor(s)**

BWILKERSON JBINGLE KKLITZKE

**Agenda Item Name**

0370 – ADMINISTRATIVE RESERVE INCREASE - HAMILTON CONSTRUCTION

**Agenda Wording**

Administrative reserve increase for the contract with Hamilton Construction for the Washington/Stevens Bridge Deck Repair for a total increase of \$500,000.00.

**Summary (Background)**

Engineering Services is requesting an increase in the administrative reserve for the Washington-Stevens Bridges project of \$500,000. This \$2.9 million project includes resurfacing the three bridges, as well as the street between the bridges and in the tunnel under Riverfront Park. The original administrative reserve was \$288,000. During construction, several significant deficiencies were found in the bridges and additional repair was needed.

Lease? NO

Grant related? NO

Public Works? YES

**Fiscal Impact**

Approved in Current Year Budget? YES

Total Cost \$ 500,000.00

Current Year Cost \$ 500,000.00

Subsequent Year(s) Cost \$ 0

**Narrative****Amount****Budget Account**

Expense \$ 500,000.00

# 3200-95164-95300-56501-86109

Expense \$ 0

# 3200-48400-95300-56501-86109

Select \$

#

Select \$

#

\$

#

\$

#



**Continuation of Wording, Summary, Approvals, and Distribution**

**Agenda Wording**

**Summary (Background)**

**Approvals**

<b><u>Dept Head</u></b>	BULLER, DAN
<b><u>Division Director</u></b>	FEIST, MARLENE
<b><u>Accounting Manager</u></b>	ORLOB, KIMBERLY
<b><u>Legal</u></b>	HARRINGTON,
<b><u>For the Mayor</u></b>	PICCOLO, MIKE

**Additional Approvals**

<b><u>PURCHASING</u></b>	NECHANICKY, JASON

**Distribution List**

	tax&licenses@spokanecity.org
jrhall@spokanecity.org	eraea@spokanecity.org
dbuller@spokanecity.org	publicworksaccounting@spokanecity.org
pyoung@spokanecity.org	jradams@spokanecity.org



## Committee Agenda Sheet

### Public Infrastructure, Environment & Sustainability Committee

<b>Committee Date</b>	10-21-24
<b>Submitting Department</b>	Engineering Services
<b>Contact Name</b>	Dan Buller
<b>Contact Email &amp; Phone</b>	<a href="mailto:dbuller@spokanecity.org">dbuller@spokanecity.org</a> , 625-6391
<b>Council Sponsor(s)</b>	Wilkerson, Bingle, Klitzke
<b>Select Agenda Item Type</b>	<input checked="" type="checkbox"/> Consent <input type="checkbox"/> Discussion    Time Requested:
<b>Agenda Item Name</b>	Cost Overrun on Washington-Stevens Br
<b>Proposed Council Action</b>	<input checked="" type="checkbox"/> Approval to proceed to Legislative Agenda <input type="checkbox"/> Information Only
<b>Summary (Background)</b>  *use the Fiscal Impact box below for relevant financial information	<ul style="list-style-type: none"> <li>• Engineering Services is requesting an increase in the administrative reserve for the Washington-Stevens Bridges project of \$500,000. This \$2.9 million project includes resurfacing the three bridges shown in the attached exhibit as well as the street between the bridges and in the tunnel under Riverfront Park. The original administrative reserve was \$288,000.</li> <li>• Unfortunately, during construction, several significant deficiencies were found in the bridges and additional repair was needed. These deficiencies were hidden beneath the asphalt overlay making them difficult to discover prior to removing that overlay.</li> <li>• The additional work items are as follows:                         <ul style="list-style-type: none"> <li>○ The south two bridge decks were of an old type of concrete which used a large aggregate (rock) resulting in excess material being removed during the hydro-demolition process which then required additional material cleanup/hauling as well as required thicker deck concrete for an added cost of about \$130,000.</li> <li>○ The south Washington bridge required about 4,000 SF of deck repair below the rebar mat. This resulted in an added cost of about \$340,000.</li> <li>○ Other needed repairs not included in the original design totaled about \$150,000.</li> </ul> </li> <li>• The additional \$500,000 of administrative reserve would cover the repairs detailed above as well as a small allotment for potential additional yet to be discovered needed repairs. The project should be completed by mid-November.</li> <li>• If approved by Council, funds for this overage would come from the arterial street fund.</li> </ul>
<b>Fiscal Impact</b> <b>Approved in current year budget?</b> <input checked="" type="checkbox"/> Yes <input type="checkbox"/> No <input type="checkbox"/> N/A Total Cost: <u>\$500,000</u> Current year cost: \$500,000 Subsequent year(s) cost:	
<b>Narrative:</b> Please provide financial due diligence review, as applicable, such as number and type of positions, grant match requirements, summary type details (personnel, maintenance and supplies, capital, revenue), impact on rates, fees, or future shared revenue	

**Funding Source**       One-time       Recurring       N/A

Specify funding source: Select Funding Source\*

Is this funding source sustainable for future years, months, etc? [Click or tap here to enter text.](#)

**Expense Occurrence**       One-time       Recurring       N/A

Other budget impacts: (revenue generating, match requirements, etc.)

**Operations Impacts** (If N/A, please give a brief description as to why)

- What impacts would the proposal have on historically excluded communities?  
Public works services and projects are designed to serve all citizens and businesses. We strive to offer a consistent level of service to all, to distribute public investment throughout the community and to respond to gaps in services identified in various City plans.
- How will data be collected, analyzed, and reported concerning the effect of the program/policy by racial, ethnic, gender identity, national origin, income level, disability, sexual orientation, or other existing disparities?  
N/A
- How will data be collected regarding the effectiveness of this program, policy, or product to ensure it is the right solution?  
Public Works follows the City's established procurement and public works bidding regulations and policies to bring items forward, and then uses contract management best practices to ensure desired outcomes and regulatory compliance.
- Describe how this proposal aligns with current City Policies, including the Comprehensive Plan, Sustainability Action Plan, Capital Improvement Program, Neighborhood Master Plans, Council Resolutions, and others?  
This work is consistent with annual budget strategies to limit costs and approved projects in the 6-year CIP.

**Council Subcommittee Review**

- Please provide a summary of council subcommittee review. If not reviewed by a council subcommittee, please explain why not.

**Washington – Stevens  
Bridge Deck Project**



Pavillion

Upper Falls  
Dam

Project location

1876 ft

Stevens St.

Washington St.

Washington St.

W North River Dr

INB  
Performing  
Arts Center

Riverside

Spokane Falls Blvd



**Agenda Sheet for City Council:**

**Committee:** PIES **Date:** 10/21/2024

**Committee Agenda type:** Consent

**Date Rec'd** 10/22/2024

**Clerk's File #** OPR 2023-1197

**Cross Ref #**

**Project #** 2023117

**Council Meeting Date:** 11/04/2024

<b>Submitting Dept</b>	ENGINEERING SERVICES	<b>Bid #</b>	
------------------------	----------------------	--------------	--

<b>Contact Name/Phone</b>	DAN BULLER 625-6391	<b>Requisition #</b>	
---------------------------	---------------------	----------------------	--

<b>Contact E-Mail</b>	DBULLER@SPOKANECITY.ORG		
-----------------------	-------------------------	--	--

<b>Agenda Item Type</b>	Contract Item		
-------------------------	---------------	--	--

<b>Council Sponsor(s)</b>	BWILKERSON JBINGLE KKLITZKE		
---------------------------	-----------------------------	--	--

<b>Agenda Item Name</b>	0370 – AMENDMENT CONSTRUCTION MANAGEMENT ON-CALL INCREASE-		
-------------------------	--	--	--

**Agenda Wording**

Amendment to Consultant Agreement with Parametrix, Inc., (Spokane, WA) for Construction Management Services 2024-2025 (non-federal) projects for an additional amount of \$800,000.00 (Various Neighborhood Councils)

**Summary (Background)**

The on-call contract with Parametrix is for two years with a one year option to extend, which is ending December 31, 2025. The original contract amount of \$800,000.00 has nearly been exhausted, therefore Engineering Services requests an additional \$800,000.00 for a new contract total of \$1,600,000.00. Funds expended under this contract are reimbursed by the public works contract for which the consultant is hired, generally state or federal loans/grants.

Lease? NO Grant related? NO Public Works? NO

**Fiscal Impact**

Approved in Current Year Budget? YES

Total Cost	\$ 800,000.00
------------	---------------

Current Year Cost	\$ 100,000.00
-------------------	---------------

Subsequent Year(s) Cost	\$ 700,000.00
-------------------------	---------------

**Narrative**

<b>Amount</b>	<b>Budget Account</b>
Expense \$ 800,000.00	# 1
Select \$	#
Select \$	#
Select \$	#
\$	#
\$	#



## Committee Agenda Sheet

### Public Infrastructure, Environment & Sustainability Committee

<b>Committee Date</b>	10-21-24
<b>Submitting Department</b>	Engineering Services
<b>Contact Name</b>	Dan Buller
<b>Contact Email &amp; Phone</b>	<a href="mailto:dbuller@spokanecity.org">dbuller@spokanecity.org</a> , 625-6391
<b>Council Sponsor(s)</b>	Wilkerson, Bingle, Klitzke
<b>Select Agenda Item Type</b>	<input checked="" type="checkbox"/> Consent <input type="checkbox"/> Discussion    Time Requested:
<b>Agenda Item Name</b>	Add'l funds for construction management on-call contract with Parametrix
<b>Proposed Council Action</b>	<input checked="" type="checkbox"/> Approval to proceed to Legislative Agenda <input type="checkbox"/> Information Only
<b>Summary (Background)</b>  *use the Fiscal Impact box below for relevant financial information	<ul style="list-style-type: none"> <li>Engineering Services has “on-call” contracts with various consultants for specialized engineering or related services (structural engineering, geotech engineering, historic resources, real estate acquisition, landscape architect, surveying, general civil design and construction management) associated with the City’s public works projects. These firms are selected based on qualifications as required by RCW 39. These agreements typically last from 2-3 years.</li> <li>The City’s contract with Parametrix for construction management for the original amount of \$800,000 is nearly out of funds and so Engineering Services is requesting an additional \$800,000.</li> <li>This contract expires on 12-31-25 and has an optional 1 year extension.</li> <li>Funds expended under this contract are reimbursed by the public works contract for which the consultant is hired, generally state or federal loans/grants.</li> </ul>
<p><b>Fiscal Impact</b></p> <p><b>Approved in current year budget?</b>    <input checked="" type="checkbox"/> Yes    <input type="checkbox"/> No    <input type="checkbox"/> N/A</p> <p>Total Cost: <u>\$800,000</u></p> <p style="padding-left: 20px;">Current year cost: \$100,000</p> <p style="padding-left: 20px;">Subsequent year(s) cost: \$700,000</p> <p><b>Narrative:</b> Please provide financial due diligence review, as applicable, such as number and type of positions, grant match requirements, summary type details (personnel, maintenance and supplies, capital, revenue), impact on rates, fees, or future shared revenue</p> <p><b>Funding Source</b>    <input checked="" type="checkbox"/> One-time    <input type="checkbox"/> Recurring    <input type="checkbox"/> N/A</p> <p>Specify funding source: Select Funding Source*</p> <p>Is this funding source sustainable for future years, months, etc? <a href="#">Click or tap here to enter text.</a></p> <p><b>Expense Occurrence</b>    <input checked="" type="checkbox"/> One-time    <input type="checkbox"/> Recurring    <input type="checkbox"/> N/A</p> <p>Other budget impacts: (revenue generating, match requirements, etc.)</p>	
<p><b>Operations Impacts (If N/A, please give a brief description as to why)</b></p> <ul style="list-style-type: none"> <li>What impacts would the proposal have on historically excluded communities? Public works services and projects are designed to serve all citizens and businesses. We strive to offer a consistent level of service to all, to distribute public investment throughout the community and to respond to gaps in services identified in various City plans.</li> </ul>	

- How will data be collected, analyzed, and reported concerning the effect of the program/policy by racial, ethnic, gender identity, national origin, income level, disability, sexual orientation, or other existing disparities?

N/A

- How will data be collected regarding the effectiveness of this program, policy, or product to ensure it is the right solution?

Public Works follows the City's established procurement and public works bidding regulations and policies to bring items forward, and then uses contract management best practices to ensure desired outcomes and regulatory compliance.

- Describe how this proposal aligns with current City Policies, including the Comprehensive Plan, Sustainability Action Plan, Capital Improvement Program, Neighborhood Master Plans, Council Resolutions, and others?

This work is consistent with annual budget strategies to limit costs and approved projects in the 6-year CIP.

### **Council Subcommittee Review**

- Please provide a summary of council subcommittee review. If not reviewed by a council subcommittee, please explain why not.



**City of Spokane**  
**CONTRACT AMENDMENT**  
Title: **2024-2025 Construction Management  
for Non-Fed Aid Projects**

This Contract Amendment is made and entered into by and between the **City of Spokane** as (“City”), a Washington municipal corporation, and **Parametrix, Inc.**, whose address is 835 North Post Street, Suite 201, Spokane, Washington 99201 as (“**Consultant**”), individually hereafter referenced as a “Party”, and together as the “Parties”.

*WHEREAS, the parties entered into a Contract wherein the **Consultant** agreed to provide On-Call Construction Management Services for Non-Fed Air Projects for the City; and*

*WHEREAS, additional funds are required to complete the end of the contract period, thus the original Contract needs to be formally Amended by this written document; and*

*NOW, THEREFORE, in consideration of these terms, the parties mutually agree as follows:*

**1. CONTRACT DOCUMENTS.**

The Contract, dated November 16, 2023, any previous amendments, addendums and / or extensions / renewals thereto, are incorporated by reference into this document as though written in full and shall remain in full force and effect except as provided herein.

**2. EFFECTIVE DATE.**

This Contract Amendment shall become effective on January 1, 2024.

**3. COMPENSATION.**

The City shall pay an additional amount not to exceed **EIGHT HUNDRED THOUSAND AND NO/100 DOLLARS (\$800,000.00)** for everything furnished and done under this Contract Amendment. This is the maximum amount to be paid under this Amendment, and shall not be exceeded without the prior written authorization of the City, memorialized with the same formality as the original Contract and this document.

IN WITNESS WHEREOF, in consideration of the terms, conditions and covenants contained, or attached and incorporated and made a part, the parties have executed this Contract Amendment by having legally-binding representatives affix their signatures below.



**PARAMETRIX, INC.**

**CITY OF SPOKANE**

By \_\_\_\_\_  
Signature Date

By \_\_\_\_\_  
Signature Date

\_\_\_\_\_  
Type or Print Name

\_\_\_\_\_  
Type or Print Name

\_\_\_\_\_  
Title

\_\_\_\_\_  
Title

Attest:

Approved as to form:

\_\_\_\_\_  
City Clerk

\_\_\_\_\_  
Assistant City Attorney

**Attachments that are part of this Agreement:**  
N/A

24-197



# CERTIFICATE OF LIABILITY INSURANCE

DATE (MM/DD/YYYY)

10/30/2023

THIS CERTIFICATE IS ISSUED AS A MATTER OF INFORMATION ONLY AND CONFERS NO RIGHTS UPON THE CERTIFICATE HOLDER. THIS CERTIFICATE DOES NOT AFFIRMATIVELY OR NEGATIVELY AMEND, EXTEND OR ALTER THE COVERAGE AFFORDED BY THE POLICIES BELOW. THIS CERTIFICATE OF INSURANCE DOES NOT CONSTITUTE A CONTRACT BETWEEN THE ISSUING INSURER(S), AUTHORIZED REPRESENTATIVE OR PRODUCER, AND THE CERTIFICATE HOLDER.

**IMPORTANT:** If the certificate holder is an **ADDITIONAL INSURED**, the policy(ies) must have **ADDITIONAL INSURED** provisions or be endorsed. If **SUBROGATION IS WAIVED**, subject to the terms and conditions of the policy, certain policies may require an endorsement. A statement on this certificate does not confer rights to the certificate holder in lieu of such endorsement(s).

<b>PRODUCER</b> AssuredPartners Design Professionals Insurance Services, LLC 3697 Mt. Diablo Blvd Suite 230 Lafayette CA 94549	<b>CONTACT NAME:</b> Jennifer Aguirre <b>PHONE (A/C, No, Ext):</b> (510) 465-3090 <b>E-MAIL ADDRESS:</b> DesignProCerts@AssuredPartners.com	<b>FAX (A/C, No):</b>
	<b>INSURER(S) AFFORDING COVERAGE</b>	
License#: 6003745 PARAINC-01	<b>INSURER A:</b> Continental Insurance Company	<b>NAIC #</b> 35289
<b>INSURED</b> Parametrix, Inc. 1019 39th Ave. SE Suite 100 Puyallup, WA 98374 (253) 604-6600	<b>INSURER B:</b> XL Specialty Insurance Co.	37885
	<b>INSURER C:</b> Valley Forge Insurance Company	20508
	<b>INSURER D:</b> Transportation Insurance Company	20494
	<b>INSURER E:</b> National Fire Insurance of Hartford	20478
	<b>INSURER F:</b>	

**COVERAGES**

CERTIFICATE NUMBER: 425009163

REVISION NUMBER:

THIS IS TO CERTIFY THAT THE POLICIES OF INSURANCE LISTED BELOW HAVE BEEN ISSUED TO THE INSURED NAMED ABOVE FOR THE POLICY PERIOD INDICATED. NOTWITHSTANDING ANY REQUIREMENT, TERM OR CONDITION OF ANY CONTRACT OR OTHER DOCUMENT WITH RESPECT TO WHICH THIS CERTIFICATE MAY BE ISSUED OR MAY PERTAIN, THE INSURANCE AFFORDED BY THE POLICIES DESCRIBED HEREIN IS SUBJECT TO ALL THE TERMS, EXCLUSIONS AND CONDITIONS OF SUCH POLICIES. LIMITS SHOWN MAY HAVE BEEN REDUCED BY PAID CLAIMS.

INSR LTR	TYPE OF INSURANCE	ADDL INSD	SUBR WVD	POLICY NUMBER	POLICY EFF (MM/DD/YYYY)	POLICY EXP (MM/DD/YYYY)	LIMITS
E	<input checked="" type="checkbox"/> <b>COMMERCIAL GENERAL LIABILITY</b> <input type="checkbox"/> CLAIMS-MADE <input checked="" type="checkbox"/> OCCUR <input checked="" type="checkbox"/> Contractual Liab <input checked="" type="checkbox"/> XCU Included GEN'L AGGREGATE LIMIT APPLIES PER: <input type="checkbox"/> POLICY <input checked="" type="checkbox"/> PRO-JECT <input type="checkbox"/> LOC <input checked="" type="checkbox"/> OTHER: WA Stop Gap/EL	Y	Y	6050531366	11/1/2023	11/1/2024	EACH OCCURRENCE \$ 1,000,000 DAMAGE TO RENTED PREMISES (Ea occurrence) \$ 1,000,000 MED EXP (Any one person) \$ 10,000 PERSONAL & ADV INJURY \$ 1,000,000 GENERAL AGGREGATE \$ 2,000,000 PRODUCTS - COMP/OP AGG \$ 2,000,000 WA Stop Gap \$ 1,000,000
A	<input checked="" type="checkbox"/> <b>AUTOMOBILE LIABILITY</b> <input checked="" type="checkbox"/> ANY AUTO <input type="checkbox"/> OWNED AUTOS ONLY <input type="checkbox"/> SCHEDULED AUTOS <input checked="" type="checkbox"/> HIRED AUTOS ONLY <input checked="" type="checkbox"/> NON-OWNED AUTOS ONLY	Y	Y	6050531352	11/1/2023	11/1/2024	COMBINED SINGLE LIMIT (Ea accident) \$ 1,000,000 BODILY INJURY (Per person) \$ BODILY INJURY (Per accident) \$ PROPERTY DAMAGE (Per accident) \$ \$
A	<input checked="" type="checkbox"/> <b>UMBRELLA LIAB</b> <input checked="" type="checkbox"/> OCCUR <input type="checkbox"/> EXCESS LIAB <input type="checkbox"/> CLAIMS-MADE <input type="checkbox"/> DED <input checked="" type="checkbox"/> RETENTION \$ 0	Y	Y	6050531433	11/1/2023	11/1/2024	EACH OCCURRENCE \$ 15,000,000 AGGREGATE \$ 15,000,000 \$
C D	<input checked="" type="checkbox"/> <b>WORKERS COMPENSATION AND EMPLOYERS' LIABILITY</b> ANY PROPRIETOR/PARTNER/EXECUTIVE OFFICER/MEMBER EXCLUDED? <input type="checkbox"/> Y <input checked="" type="checkbox"/> N (Mandatory in NH) If yes, describe under DESCRIPTION OF OPERATIONS below		Y	6050531383 6050531402	11/1/2023 11/1/2023	11/1/2024 11/1/2024	<input checked="" type="checkbox"/> PER STATUTE <input type="checkbox"/> OTH-ER WA Stop Gap E.L. EACH ACCIDENT \$ 1,000,000 E.L. DISEASE - EA EMPLOYEE \$ 1,000,000 E.L. DISEASE - POLICY LIMIT \$ 1,000,000
B	<input type="checkbox"/> Professional Liability <input type="checkbox"/> Claims Made <input type="checkbox"/> Pollution Liability Included		Y	DPR5020288	11/1/2023	11/1/2024	Per Claim \$1,000,000 Annual Aggregate \$1,000,000 Retroactive Date: 01/01/1969

DESCRIPTION OF OPERATIONS / LOCATIONS / VEHICLES (ACORD 101, Additional Remarks Schedule, may be attached if more space is required)

Umbrella Liability policy is a follow-form to underlying General Liability/Auto Liability/Employers Liability.  
 Project Name: Landscape Architect Services for 2019-2020 Federal Aid Projects -- State of Washington and City of Spokane, their officers, employees, and agents are named as Additional Insured as respects General and Auto Liability as required per written contract or agreement. General Liability insurance is Primary/Non-Contributory per policy form wording. Insurance coverage includes Waiver of Subrogation per the attached.

**CERTIFICATE HOLDER****CANCELLATION** 30 Days Notice of Cancellation

City of Spokane  
 Attn: Dan Buller  
 808 W Spokane Falls Blvd.  
 Spokane WA 99201

SHOULD ANY OF THE ABOVE DESCRIBED POLICIES BE CANCELLED BEFORE THE EXPIRATION DATE THEREOF, NOTICE WILL BE DELIVERED IN ACCORDANCE WITH THE POLICY PROVISIONS.

AUTHORIZED REPRESENTATIVE

© 1988-2015 ACORD CORPORATION. All rights reserved.



**Blanket Additional Insured - Owners, Lessees or Contractors - with Products-Completed Operations Coverage Endorsement**

This endorsement modifies insurance provided under the following:

COMMERCIAL GENERAL LIABILITY COVERAGE PART

It is understood and agreed as follows:

- I. **WHO IS AN INSURED** is amended to include as an **Insured** any person or organization whom you are required by **written contract** to add as an additional insured on this **coverage part**, but only with respect to liability for **bodily injury, property damage or personal and advertising injury** caused in whole or in part by your acts or omissions, or the acts or omissions of those acting on your behalf:
  - A. in the performance of your ongoing operations subject to such **written contract**; or
  - B. in the performance of **your work** subject to such **written contract**, but only with respect to **bodily injury or property damage** included in the **products-completed operations hazard**, and only if:
    - 1. the **written contract** requires you to provide the additional insured such coverage; and
    - 2. this **coverage part** provides such coverage.

II. But if the **written contract** requires:

- A. additional insured coverage under the 11-85 edition, 10-93 edition, or 10-01 edition of CG2010, or under the 10-01 edition of CG2037; or
- B. additional insured coverage with "arising out of" language; or
- C. additional insured coverage to the greatest extent permissible by law;

then paragraph I. above is deleted in its entirety and replaced by the following:

**WHO IS AN INSURED** is amended to include as an **Insured** any person or organization whom you are required by **written contract** to add as an additional insured on this **coverage part**, but only with respect to liability for **bodily injury, property damage or personal and advertising injury** arising out of **your work** that is subject to such **written contract**.

III. Subject always to the terms and conditions of this policy, including the limits of insurance, the Insurer will not provide such additional insured with:

- A. coverage broader than required by the **written contract**; or
- B. a higher limit of insurance than required by the **written contract**.

IV. The insurance granted by this endorsement to the additional insured does not apply to **bodily injury, property damage, or personal and advertising injury** arising out of:

- A. the rendering of, or the failure to render, any professional architectural, engineering, or surveying services, including:
  - 1. the preparing, approving, or failing to prepare or approve maps, shop drawings, opinions, reports, surveys, field orders, change orders or drawings and specifications; and
  - 2. supervisory, inspection, architectural or engineering activities; or
- B. any premises or work for which the additional insured is specifically listed as an additional insured on another endorsement attached to this **coverage part**.

V. Under **COMMERCIAL GENERAL LIABILITY CONDITIONS**, the Condition entitled **Other Insurance** is amended to add the following, which supersedes any provision to the contrary in this Condition or elsewhere in this **coverage part**:

CNA75079XX (10-16)

Page 1 of 2

Nat'l Fire Ins Co of Hartford

Insured Name: PARAMETRIX, INC.

Policy No: 6050531366

Endorsement No: 15



**Blanket Additional Insured - Owners, Lessees or Contractors - with Products-Completed Operations Coverage Endorsement****Primary and Noncontributory Insurance**

With respect to other insurance available to the additional insured under which the additional insured is a named insured, this insurance is primary to and will not seek contribution from such other insurance, provided that a **written contract** requires the insurance provided by this policy to be:

1. primary and non-contributing with other insurance available to the additional insured; or
2. primary and to not seek contribution from any other insurance available to the additional insured.

But except as specified above, this insurance will be excess of all other insurance available to the additional insured.

**VI. Solely with respect to the insurance granted by this endorsement, the section entitled COMMERCIAL GENERAL LIABILITY CONDITIONS is amended as follows:**

The Condition entitled **Duties In The Event of Occurrence, Offense, Claim or Suit** is amended with the addition of the following:

Any additional insured pursuant to this endorsement will as soon as practicable:

1. give the Insurer written notice of any **claim**, or any **occurrence** or offense which may result in a **claim**;
2. send the Insurer copies of all legal papers received, and otherwise cooperate with the Insurer in the investigation, defense, or settlement of the **claim**; and
3. make available any other insurance, and tender the defense and indemnity of any **claim** to any other insurer or self-insurer, whose policy or program applies to a loss that the Insurer covers under this **coverage part**. However, if the **written contract** requires this insurance to be primary and non-contributory, this paragraph 3. does not apply to insurance on which the additional insured is a named insured.

The Insurer has no duty to defend or indemnify an additional insured under this endorsement until the Insurer receives written notice of a **claim** from the additional insured.

**VII. Solely with respect to the insurance granted by this endorsement, the section entitled DEFINITIONS is amended to add the following definition:**

**Written contract** means a written contract or written agreement that requires you to make a person or organization an additional insured on this **coverage part**, provided the contract or agreement:

- A. is currently in effect or becomes effective during the term of this policy; and
- B. was executed prior to:
  1. the **bodily injury** or **property damage**; or
  2. the offense that caused the **personal and advertising injury**;for which the additional insured seeks coverage.

Any coverage granted by this endorsement shall apply solely to the extent permissible by law.

All other terms and conditions of the Policy remain unchanged.

This endorsement, which forms a part of and is for attachment to the Policy issued by the designated Insurers, takes effect on the effective date of said Policy at the hour stated in said Policy, unless another effective date is shown below, and expires concurrently with said Policy.



Waiver of Transfer of Rights of Recovery Against Others to the Insurer Endorsement

This endorsement modifies insurance provided under the following:

- COMMERCIAL GENERAL LIABILITY COVERAGE PART
- PRODUCTS/COMPLETED OPERATIONS LIABILITY COVERAGE PART

SCHEDULE
<b>Name Of Person Or Organization:</b>
ANY PERSON OR ORGANIZATION WHOM THE NAMED INSURED HAS AGREED IN WRITING IN A CONTRACT OR AGREEMENT TO WAIVE SUCH RIGHTS OF RECOVERY, BUT ONLY IF SUCH CONTRACT OR AGREEMENT:
1. IS IN EFFECT OR BECOMES EFFECTIVE DURING THE TERM OF THIS COVERAGE PART; AND 2. WAS EXECUTED PRIOR TO THE BODILY INJURY, PROPERTY DAMAGE OR PERSONAL AND ADVERTISING INJURY GIVING RISE TO THE CLAIM.

(Information required to complete this Schedule, if not shown above, will be shown in the Declarations.)

Under **COMMERCIAL GENERAL LIABILITY CONDITIONS**, it is understood and agreed that the condition entitled **Transfer Of Rights Of Recovery Against Others To Us** is amended by the addition of the following:

With respect to the person or organization shown in the Schedule above, the Insurer waives any right of recovery the Insurer may have against such person or organization because of payments the Insurer makes for injury or damage arising out of the **Named Insured's** ongoing operations or **your work** included in the **products-completed operations hazard**.

All other terms and conditions of the Policy remain unchanged.

This endorsement, which forms a part of and is for attachment to the Policy issued by the designated Insurers, takes effect on the effective date of said Policy at the hour stated in said Policy, unless another effective date is shown below, and expires concurrently with said Policy.

10020006660505313664450



CONTRACTORS EXTENDED COVERAGE ENDORSEMENT - BUSINESS AUTO PLUS

**THIS ENDORSEMENT CHANGES THE POLICY. PLEASE READ IT CAREFULLY.**

This endorsement modifies insurance provided under the following:

BUSINESS AUTO COVERAGE FORM

**I. LIABILITY COVERAGE**

**A. Who Is An Insured**

The following is added to **Section II, Paragraph A.1., Who Is An Insured:**

1. a. Any incorporated entity of which the Named Insured owns a majority of the voting stock on the date of inception of this Coverage Form; provided that,
  - b. The insurance afforded by this provision **A.1.** does not apply to any such entity that is an **insured** under any other liability "policy" providing **auto** coverage.
2. Any organization you newly acquire or form, other than a limited liability company, partnership or joint venture, and over which you maintain majority ownership interest.

The insurance afforded by this provision **A.2.:**

- a. Is effective on the acquisition or formation date, and is afforded only until the end of the policy period of this Coverage Form, or the next anniversary of its inception date, whichever is earlier.
- b. Does not apply to:
  - (1) **Bodily injury or property damage** caused by an **accident** that occurred before you acquired or formed the organization; or
  - (2) Any such organization that is an **insured** under any other liability "policy" providing **auto** coverage.
3. Any person or organization that you are required by a written contract to name as an additional insured is an **insured** but only with respect to their legal liability for acts or omissions of a person, who qualifies as an **insured** under **SECTION II – WHO IS AN INSURED** and for whom Liability Coverage is afforded under this policy. If required by written contract, this insurance will be primary and non-contributory to insurance on which the additional insured is a Named Insured.
4. An **employee** of yours is an **insured** while operating an **auto** hired or rented under a contract or agreement in that **employee's** name, with your permission, while performing duties related to the conduct of your business.

"Policy", as used in this provision **A. Who Is An Insured**, includes those policies that were in force on the inception date of this Coverage Form but:

1. Which are no longer in force; or
2. Whose limits have been exhausted.

**B. Bail Bonds and Loss of Earnings**

**Section II, Paragraphs A.2. (2) and A.2. (4)** are revised as follows:

1. In **a.(2)**, the limit for the cost of bail bonds is changed from \$2,000 to \$5,000; and
2. In **a.(4)**, the limit for the loss of earnings is changed from \$250 to \$500 a day.



**C. Fellow Employee**

**Section II, Paragraph B.5** does not apply.

Such coverage as is afforded by this provision C. is excess over any other collectible insurance.

**II. PHYSICAL DAMAGE COVERAGE**

**A. Glass Breakage – Hitting A Bird Or Animal – Falling Objects Or Missiles**

The following is added to **Section III, Paragraph A.3.:**

With respect to any covered **auto**, any deductible shown in the Declarations will not apply to glass breakage if such glass is repaired, in a manner acceptable to us, rather than replaced.

**B. Transportation Expenses**

**Section III, Paragraph A.4.a.** is revised, with respect to transportation expense incurred by you, to provide:

- a. \$60 per day, in lieu of \$20; subject to
- b. \$1,800 maximum, in lieu of \$600.

**C. Loss of Use Expenses**

**Section III, Paragraph A.4.b.** is revised, with respect to loss of use expenses incurred by you, to provide:

- a. \$1,000 maximum, in lieu of \$600.

**D. Hired "Autos"**

The following is added to **Section III. Paragraph A.:**

**5. Hired "Autos"**

If Physical Damage coverage is provided under this policy, and such coverage does not extend to Hired Autos, then Physical Damage coverage is extended to:

- a. Any covered **auto** you lease, hire, rent or borrow without a driver; and
- b. Any covered **auto** hired or rented by your **employee** without a driver, under a contract in that individual **employee's** name, with your permission, while performing duties related to the conduct of your business.
- c. The most we will pay for any one **accident** or **loss** is the actual cash value, cost of repair, cost of replacement or \$75,000, whichever is less, minus a \$500 deductible for each covered auto. No deductible applies to **loss** caused by fire or lightning.
- d. The physical damage coverage as is provided by this provision is equal to the physical damage coverage(s) provided on your owned **autos**.
- e. Such physical damage coverage for hired **autos** will:
  - (1) Include loss of use, provided it is the consequence of an **accident** for which the Named Insured is legally liable, and as a result of which a monetary loss is sustained by the leasing or rental concern.
  - (2) Such coverage as is provided by this provision will be subject to a limit of \$750 per **accident**.

**E. Airbag Coverage**

The following is added to **Section III, Paragraph B.3.:**

The accidental discharge of an airbag shall not be considered mechanical breakdown.



**F. Electronic Equipment**

**Section III, Paragraphs B.4.c and B.4.d.** are deleted and replaced by the following:

- c. Physical Damage Coverage on a covered **auto** also applies to **loss** to any permanently installed electronic equipment including its antennas and other accessories
- d. A \$100 per occurrence deductible applies to the coverage provided by this provision.

**G. Diminution In Value**

The following is added to **Section III, Paragraph B.6.:**

Subject to the following, the **diminution in value** exclusion does not apply to:

- a. Any covered **auto** of the private passenger type you lease, hire, rent or borrow, without a driver for a period of 30 days or less, while performing duties related to the conduct of your business; and
- b. Any covered **auto** of the private passenger type hired or rented by your **employee** without a driver for a period of 30 days or less, under a contract in that individual **employee's** name, with your permission, while performing duties related to the conduct of your business.
- c. Such coverage as is provided by this provision is limited to a **diminution in value** loss arising directly out of accidental damage and not as a result of the failure to make repairs; faulty or incomplete maintenance or repairs; or the installation of substandard parts.
- d. The most we will pay for **loss** to a covered **auto** in any one accident is the lesser of:
  - (1) \$5,000; or
  - (2) 20% of the **auto's** actual cash value (ACV).

**III. Drive Other Car Coverage – Executive Officers**

The following is added to **Sections II and III:**

- 1. Any **auto** you don't own, hire or borrow is a covered **auto** for Liability Coverage while being used by, and for Physical Damage Coverage while in the care, custody or control of, any of your "executive officers", except:
  - a. An **auto** owned by that "executive officer" or a member of that person's household; or
  - b. An **auto** used by that "executive officer" while working in a business of selling, servicing, repairing or parking **autos**.

Such Liability and/or Physical Damage Coverage as is afforded by this provision.

- (1) Equal to the greatest of those coverages afforded any covered **auto**; and
- (2) Excess over any other collectible insurance.

- 2. For purposes of this provision, "executive officer" means a person holding any of the officer positions created by your charter, constitution, by-laws or any other similar governing document, and, while a resident of the same household, includes that person's spouse.

Such "executive officers" are **insureds** while using a covered **auto** described in this provision.

**IV. BUSINESS AUTO CONDITIONS**

**A. Duties In The Event Of Accident, Claim, Suit Or Loss**

The following is added to **Section IV, Paragraph A.2.a.:**





- (4) Your **employees** may know of an **accident** or **loss**. This will not mean that you have such knowledge, unless such **accident** or **loss** is known to you or if you are not an individual, to any of your executive officers or partners or your insurance manager.

The following is added to **Section IV, Paragraph A.2.b.:**

- (6) Your **employees** may know of documents received concerning a claim or **suit**. This will not mean that you have such knowledge, unless receipt of such documents is known to you or if you are not an individual, to any of your executive officers or partners or your insurance manager.

**B. Transfer Of Rights Of Recovery Against Others To Us**

The following is added to **Section IV, Paragraph A.5. Transfer Of Rights Of Recovery Against Others To Us:**

We waive any right of recovery we may have, because of payments we make for injury or damage, against any person or organization for whom or which you are required by written contract or agreement to obtain this waiver from us.

This injury or damage must arise out of your activities under a contract with that person or organization.

You must agree to that requirement prior to an **accident** or **loss**.

**C. Concealment, Misrepresentation or Fraud**

The following is added to **Section IV, Paragraph B.2.:**

Your failure to disclose all hazards existing on the date of inception of this Coverage Form shall not prejudice you with respect to the coverage afforded provided such failure or omission is not intentional.

**D. Other Insurance**

The following is added to **Section IV, Paragraph B.5.:**

Regardless of the provisions of Paragraphs **5.a.** and **5.d.** above, the coverage provided by this policy shall be on a primary non-contributory basis. This provision is applicable only when required by a written contract.

That written contract must have been entered into prior to **Accident** or **Loss**.

**E. Policy Period, Coverage Territory**

**Section IV, Paragraph B. 7.(5).(a).** is revised to provide:

- a. 45 days of coverage in lieu of 30 days.

**V. DEFINITIONS**

**Section V. paragraph C.** is deleted and replaced by the following:

**Bodily injury** means bodily injury, sickness or disease sustained by a person, including mental anguish, mental injury or death resulting from any of these.



WAIVER OF OUR RIGHT TO RECOVER FROM OTHERS ENDORSEMENT

We have the right to recover our payments from anyone liable for an injury covered by this policy. We will not enforce our right against the person or organization named in the Schedule.

This agreement shall not operate directly or indirectly to benefit anyone not named in the Schedule.

Schedule

Any Person or Organization on whose behalf you are required to obtain this waiver of our right to recover from under a written contract or agreement.

The premium charge for the endorsement is reflected in the Schedule of Operations.

All other terms and conditions of the policy remain unchanged.

This endorsement, which forms a part of and is for attachment to the policy issued by the designated Insurers, takes effect on the Policy Effective Date of said policy at the hour stated in said policy, unless another effective date (the Endorsement Effective Date) is shown below, and expires concurrently with said policy unless another expiration date is shown below.



BLANKET WAIVER OF OUR RIGHT TO RECOVER FROM OTHERS

This endorsement changes the policy to which it is attached.

It is agreed that **Part One - Workers' Compensation Insurance G. Recovery From Others** and **Part Two - Employers' Liability Insurance H. Recovery From Others** are amended by adding the following:

We will not enforce our right to recover against persons or organizations. (This agreement applies only to the extent that you perform work under a written contract that requires you to obtain this agreement from us.)

**PREMIUM CHARGE** - Refer to the Schedule of Operations

The charge will be an amount to which you and we agree that is a percentage of the total standard premium for California exposure. The amount is 2%.

All other terms and conditions of the policy remain unchanged.

This endorsement, which forms a part of and is for attachment to the policy issued by the designated Insurers, takes effect on the Policy Effective Date of said policy at the hour stated in said policy, unless another effective date (the Endorsement Effective Date) is shown below, and expires concurrently with said policy unless another expiration date is shown below.

Form No: G-19160-B (11-1997)

Endorsement Effective Date:

Endorsement No: 2; Page: 1 of 1

Underwriting Company: American Casualty Company of Reading, Pennsylvania, 151 N Franklin St,  
Chicago, IL 60606

Policy No: WC 6 50531383 Policy

Endorsement Expiration Date:



< Business Lookup

License Information:

[New search](#) [Back to results](#)

Entity name: PARAMETRIX, INC.

Business name: PARAMETRIX INC

Entity type: [Profit Corporation](#)

UBI #: 600-135-349

Business ID: 001

Location ID: 0006

Location: Active

Location address: 835 N. POST STREET, SUITE 201  
BLDG 201  
SPOKANE WA 99201

Mailing address: PARAMETRIX INC  
1019 39TH AVE SE SUITE 100  
PUYALLUP WA 98374

Excise tax and reseller permit status: [Click here](#)

Secretary of State status: [Click here](#)

Endorsements

Endorsements held at this location	License #	Count	Details	Status	Expiration date	First issuance date
<a href="#">Spokane General Business</a>				Active	Apr-30-2025	Dec-18-2018

Governing People May include governing people not registered with Secretary of State

Governing people	Title
DIEMER, BRENT	
FLINT, ROGER	



**Governing people**

**Title**

WILLIS, JOHN

**Registered Trade Names**

**Registered trade names**

**Status**

**First issued**

PARAMETRIX INC

Active

Dec-18-2018

PARAMETRIX, INC

Active

Dec-30-2021

PARAMETRIX, INC.

Active

Sep-16-1986

[View Additional Locations](#)

The Business Lookup information is updated nightly. Search date and time: 10/7/2024 8:21:26 AM

**Contact us**

How are we doing?

**Take our survey!**

Don't see what you expected?

**Check if your browser is supported**





**Agenda Sheet for City Council:**

**Committee:** PIES **Date:** 10/21/2024

**Committee Agenda type:** Consent

**Date Rec'd** 10/22/2024

**Clerk's File #** OPR 2023-0978

**Cross Ref #** OPR 2023-0979

**Project #**

**Council Meeting Date:** 11/04/2024

<b>Submitting Dept</b>	FACILITIES MANAGEMENT	<b>Bid #</b>	
------------------------	-----------------------	--------------	--

<b>Contact Name/Phone</b>	DAVE STEELE 625-6064	<b>Requisition #</b>	VALUE BLANKET
---------------------------	----------------------	----------------------	---------------

<b>Contact E-Mail</b>	DSTEELE@SPOKANECITY.ORG		
-----------------------	-------------------------	--	--

<b>Agenda Item Type</b>	Purchase w/o Contract		
-------------------------	-----------------------	--	--

<b>Council Sponsor(s)</b>	BWILKERSON JBINGLE KKLITZKE		
---------------------------	-----------------------------	--	--

<b>Agenda Item Name</b>	5900 FACILITIES CITYWIDE HVAC MASTER CONTROLS VALUE BLANKET		
-------------------------	---	--	--

**Agenda Wording**

The Facilities Dept, in partnership with the City's Fire Dept, has developed a scope of services for HVAC with ATS Inland NW for the replacement of HVAC equipment & full controls upgrades for the HVAC system at Station 1.

**Summary (Background)**

The Facilities Dept, with the City's Fire Dept, has developed a scope of services under the City's value blanket for HVAC with ATS Inland NW, Spokane, WA for the replacement of equipment and controls upgrades for the HVAC system at Fire Station 1. This work will complete the replacement of failing HVAC equipment at Station 1, replacing antiquated sensors, and a new integrated digital controls package that ties Station 1 into the City's central HVAC software system.

Lease? NO Grant related? NO Public Works? YES

**Fiscal Impact**

Approved in Current Year Budget? YES

Total Cost	\$ 1,010,000.00
------------	-----------------

Current Year Cost	\$ 1,010,000.00
-------------------	-----------------

Subsequent Year(s) Cost	\$ 500,000.00
-------------------------	---------------

**Narrative**

OPR 2023-0978 not to exceed \$1,010,000.00 for 2024 (adding an additional \$160,000.00) for parts before sales tax.

**Amount**

**Budget Account**

Expense	\$ 850,000.00	# various--annual amount + amendment before
---------	---------------	---

Expense	\$ 160,000.00	# various--additional amount before sales tax
---------	---------------	---

Select	\$	#
--------	----	---

Select	\$	#
--------	----	---

	\$	#
--	----	---

	\$	#
--	----	---



**Continuation of Wording, Summary, Approvals, and Distribution**

**Agenda Wording**

**Summary (Background)**

**Approvals**

<b><u>Dept Head</u></b>	TEAL, JEFFREY
<b><u>Division Director</u></b>	BOSTON, MATTHEW
<b><u>Accounting Manager</u></b>	MURRAY, MICHELLE
<b><u>Legal</u></b>	HARRINGTON,
<b><u>For the Mayor</u></b>	PICCOLO, MIKE

**Additional Approvals**

<b><u>PURCHASING</u></b>	PRINCE, THEA

**Distribution List**

Paul Bonner paulb@atsinlandnw.com	laga@spokanecity.org
mmurray@spokanecity.org	klong@spokanecity.org
kbustos@spokanecity.org	dstele@spokanecity.org

## Committee Agenda Sheet

### Public Infrastructure, Environment & Sustainability Committee

<b>Submitting Department</b>	Facilities
<b>Contact Name</b>	Dave Steele
<b>Contact Email &amp; Phone</b>	509-625-6064
<b>Council Sponsor(s)</b>	CP Wilkerson, CM Bingle, CM Klitzke
<b>Select Agenda Item Type</b>	<input checked="" type="checkbox"/> Consent <input type="checkbox"/> Discussion    Time Requested:
<b>Agenda Item Name</b>	Fire Station #1 - HVAC Replacements & Controls Updates ARPA Funds
<b>Summary (Background)</b>  *Use the Fiscal Impact box below for relevant financial information	The Facilities Department, in partnership with the City of Spokane Fire Department has developed a scope of services under the City of Spokane’s master contract for HVAC with ATS Inland Northwest for the replacement of HVAC equipment and full controls upgrades for the HVAC systems at Fire Station #1. This work will complete the replacement of failing HVAC equipment at Station #1, replacing antiquated sensors, and a new integrated digital controls package that ties Fire Station #1 into the City of Spokane’s central HVAC software server. This work will be completed under the existing master contract with ATS Inland NW.
<b>Proposed Council Action</b>	Approval of master contract amendments to increase spending authority.  Value Blanket (OPR 2023-0978) \$160,000.00 additional Installation Labor Contract (OPR 2023-0979) \$329,320.00 additional
<b>Fiscal Impact</b>	
Total Expense: OPR 2023-0978 PARTS <u>not to exceed \$1,010,000 in 2024 Additional \$160,000.00</u> OPR 2023-0979 LABOR <u>not to exceed \$1,025,000 in 2024 Additional \$329,320.00</u>	
Approved in current year budget? <input checked="" type="checkbox"/> Yes <input type="checkbox"/> No <input type="checkbox"/> N/A	
Funding Source <input checked="" type="checkbox"/> One-time <input type="checkbox"/> Recurring <input type="checkbox"/> N/A Specify funding source: ARPA,	
Expense Occurrence <input checked="" type="checkbox"/> One-time <input type="checkbox"/> Recurring <input type="checkbox"/> N/A	
Other budget impacts: (revenue generating, match requirements, etc.) Reduction of long term replacement costs by completing proper ongoing maintenance.	
<b>Operations Impacts (If N/A, please give a brief description as to why)</b>	
What impacts would the proposal have on historically excluded communities?  NA – This work focuses on providing upgrades and repairs to Fire Station #1 which provides a direct services for a wide variety of underserved and historically underserved minority communities.	



How will data be collected, analyzed, and reported concerning the effect of the program/policy by racial, ethnic, gender identity, national origin, income level, disability, sexual orientation, or other existing disparities?

NA – This work focuses on providing a greater level of service and efficiency from the existing facility, allowing the building to be more efficient, but does not lean itself to the collection of this data.

How will data be collected regarding the effectiveness of this program, policy, or product to ensure it is the right solution?

NA – This work focuses on providing a greater level of service and efficiency from the existing facility, allowing the building to be more efficient, but does not lean itself to the collection of this data.

Describe how this proposal aligns with current City Policies, including the Comprehensive Plan, Sustainability Action Plan, Capital Improvement Program, Neighborhood Master Plans, Council Resolutions, and others?

Reduction of long term energy use by improving the control and management of the building, while upgrading several pieces of equipment with high efficiency replacements.



## Task Assignment #7 Parts & Equipment

### Fire Station 1 Control System Replacement

Line Item 27: VAV-SD2A-E (32)	\$19,108.80
Line Item 30: VLC 1188 (3)	\$5,157
Line Item 33: VLC-444e (3)	\$1,944
Line Item 35: VLC 550 (5)	\$3,026.25
Line Item 52: ACM-064	\$1,831.5
Line Item 73: ACM	\$3,936.60
Line Item 170: ACM Battery (1)	\$831.15
Line Item 171: CO/NO2 Sensor (2)	\$2,802.70
Line Item 173: Duct Probe Sensor (6)	\$126.84
Line Item 174: Current Sensing Relay (12)	\$287.04
Line Item 176: Filter DP Sensor (2)	\$69.34
Line Item 177: Low Limit Temp Detector (2)	\$430.84
Line Item 178: Duct Averaging Sensor (3)	\$379.35
Line Item 180: Stainless Wall Sensor (44)	\$1,015.52
Line Item 181: RIB Relay (15)	\$511.95
Line Item 182: 90lb Modulating Actuator (4)	\$1,679.04
Line Item 185: Outside Air Sensor (1)	\$63.61
Line Item 187: Strap on Temperature Sensor (4)	\$271.32
Line Item 188: MS/TP BACnet Relay (7)	\$1,064.84
Line Item 189: 45lb actuator (3)	\$480.48
Line Item 190: Differential Airflow Sensor (2)	\$391.18
Line Item 197: Small Enclosure (43)	\$3,141.58
Line Item 198: Global Enclosure (1)	\$164
Line Item 199: Outdoor Condensing Unit (2)	\$83,580.80
Line Item 200: Unit Heater (1)	\$7,038
Line Item 201: Air Velocity Transmitter (30)	\$7,075.80
Line Item 202: 3-Way Globe Valve (2)	\$3,651.30
Line Item 203: 1 inch 2-Way Ball Valve (5)	\$2,097
Line Item 204: 1 inch 3-Way Ball Valve (1)	\$426.40
Line Item 205: Exhaust Fan (2)	\$5,100.77

**Assumptions / Clarifications**

- 1) Proposal excludes applicable taxes.
- 2) Proposal excludes installation.

- **Pricing for above mentioned task assignment #7 = \$157,605**

*Pricing valid for period of 60 days from date of proposal.*

**Paul Bonner**  
ATS Inland NW





**Agenda Sheet for City Council:**

**Committee:** PIES **Date:** 10/21/2024

**Committee Agenda type:** Consent

**Date Rec'd** 10/22/2024

**Clerk's File #** OPR 2023-0979

**Cross Ref #** OPR 2023-0978

**Project #**

**Council Meeting Date:** 11/04/2024

<b>Submitting Dept</b>	FACILITIES MANAGEMENT	<b>Bid #</b>	
------------------------	-----------------------	--------------	--

<b>Contact Name/Phone</b>	DAVE STEELE 625-6064	<b>Requisition #</b>	MASTER
---------------------------	----------------------	----------------------	--------

<b>Contact E-Mail</b>	DSTEEL@SPOKANECITY.ORG		
-----------------------	------------------------	--	--

<b>Agenda Item Type</b>	Contract Item		
-------------------------	---------------	--	--

<b>Council Sponsor(s)</b>	BWILKERSON JBINGLE KKLITZKE		
---------------------------	-----------------------------	--	--

<b>Agenda Item Name</b>	5900 FACILITIES CITY HVAC MASTER CONTROLS INSTALLATION CONTRACT		
-------------------------	---	--	--

**Agenda Wording**

The Facilities Department, with the City of Spokane Fire Department, has developed a scope of services under the City of Spokane's master contract with ATS Inland Northwest for the replacement of HVAC equipment & full controls upgrade at Station 1.

**Summary (Background)**

The Facilities Department has developed a scope of services under the City of Spokane's master contract with ATS Inland NW, Spokane WA for the replacement of HVAC equipment and full controls upgrades for the HVAC system at Fire Station 1. The work will complete the replacement of the failing HVAC equipment at Station 1, replacing antiquated sensors & a new integrated digital controls package that ties Station 1 into the City of Spokane's central HVAC software server.

Lease? NO Grant related? NO Public Works? YES

**Fiscal Impact**

Approved in Current Year Budget? YES

Total Cost \$ 629,320

Current Year Cost \$ 629,320

Subsequent Year(s) Cost \$ 300,000.00

**Narrative**

Approval of master contract amendments to increase spending authority on the OPR 2023-0979 Installation labor contract \$325,050.00.

**Amount**

**Budget Account**

Expense	\$ 300,000	# various--2024 annual amount before sales tax
Expense	\$ 329,320 (rounded)	# various--2024 additional amount before sales tax
Select	\$	#
Select	\$	#
	\$	#
	\$	#



## Continuation of Wording, Summary, Approvals, and Distribution

### Agenda Wording

### Summary (Background)

#### **Approvals**

##### Dept Head

TEAL, JEFFREY

##### Division Director

BOSTON, MATTHEW

##### Accounting Manager

BUSTOS, KIM

##### Legal

SCHOEDEL, ELIZABETH

##### For the Mayor

PICCOLO, MIKE

#### **Additional Approvals**

##### PURCHASING

PRINCE, THEA

#### **Distribution List**

Paul Bonner paulb@atsinlandnw.com

laga@spokanecity.org

mmurray@spokanecity.org

klong@spokanecity.org

dstele@spokanecity.org

kbustos@spokanecity.org

tprince@spokanecity.org

## Committee Agenda Sheet

### Public Infrastructure, Environment & Sustainability Committee

<b>Submitting Department</b>	Facilities
<b>Contact Name</b>	Dave Steele
<b>Contact Email &amp; Phone</b>	509-625-6064
<b>Council Sponsor(s)</b>	CP Wilkerson, CM Bingle, CM Klitzke
<b>Select Agenda Item Type</b>	<input checked="" type="checkbox"/> Consent <input type="checkbox"/> Discussion    Time Requested:
<b>Agenda Item Name</b>	Fire Station #1 - HVAC Replacements & Controls Updates ARPA Funds
<b>Summary (Background)</b>  *Use the Fiscal Impact box below for relevant financial information	The Facilities Department, in partnership with the City of Spokane Fire Department has developed a scope of services under the City of Spokane’s master contract for HVAC with ATS Inland Northwest for the replacement of HVAC equipment and full controls upgrades for the HVAC systems at Fire Station #1. This work will complete the replacement of failing HVAC equipment at Station #1, replacing antiquated sensors, and a new integrated digital controls package that ties Fire Station #1 into the City of Spokane’s central HVAC software server. This work will be completed under the existing master contract with ATS Inland NW.
<b>Proposed Council Action</b>	Approval of master contract amendments to increase spending authority.  Value Blanket (OPR 2023-0978) \$160,000.00 additional Installation Labor Contract (OPR 2023-0979) \$329,320.00 additional
<b>Fiscal Impact</b>	
Total Expense: OPR 2023-0978 PARTS <u>not to exceed \$1,010,000 in 2024 Additional \$160,000.00</u> OPR 2023-0979 LABOR <u>not to exceed \$1,025,000 in 2024 Additional \$329,320.00</u>	
Approved in current year budget? <input checked="" type="checkbox"/> Yes <input type="checkbox"/> No <input type="checkbox"/> N/A	
Funding Source <input checked="" type="checkbox"/> One-time <input type="checkbox"/> Recurring <input type="checkbox"/> N/A Specify funding source: ARPA,	
Expense Occurrence <input checked="" type="checkbox"/> One-time <input type="checkbox"/> Recurring <input type="checkbox"/> N/A	
Other budget impacts: (revenue generating, match requirements, etc.) Reduction of long term replacement costs by completing proper ongoing maintenance.	
<b>Operations Impacts (If N/A, please give a brief description as to why)</b>	
What impacts would the proposal have on historically excluded communities?  NA – This work focuses on providing upgrades and repairs to Fire Station #1 which provides a direct services for a wide variety of underserved and historically underserved minority communities.	

How will data be collected, analyzed, and reported concerning the effect of the program/policy by racial, ethnic, gender identity, national origin, income level, disability, sexual orientation, or other existing disparities?

NA – This work focuses on providing a greater level of service and efficiency from the existing facility, allowing the building to be more efficient, but does not lean itself to the collection of this data.

How will data be collected regarding the effectiveness of this program, policy, or product to ensure it is the right solution?

NA – This work focuses on providing a greater level of service and efficiency from the existing facility, allowing the building to be more efficient, but does not lean itself to the collection of this data.

Describe how this proposal aligns with current City Policies, including the Comprehensive Plan, Sustainability Action Plan, Capital Improvement Program, Neighborhood Master Plans, Council Resolutions, and others?

Reduction of long term energy use by improving the control and management of the building, while upgrading several pieces of equipment with high efficiency replacements.





**CITY OF SPOKANE**  
**CONTRACT AMENDMENT**  
**Title: HVAC CONTROL SYSTEM INSTALL/REPLACE  
AND MAINTENANCE**

This Contract Amendment is made and entered into by and between the **CITY OF SPOKANE** as (“City”), a Washington municipal corporation, and **ATS INLAND NW, LLC.**, whose address is 9507 East Sprague Avenue, Spokane Valley, Washington 99206 as (“Contractor”), individually hereafter referenced as a “Party”, and together as the “Parties”.

WHEREAS, the parties entered into a Contract wherein the Contractor agreed to provide the As-Needed HVAC Control System Install/Replace and Maintenance for the City; and

WHEREAS, the City is authorized to expend ARPA funds for this contract amendment in accordance with Ordinance C36520, passed June 10, 2024, (section 1 (20)); and

WHEREAS, the Contractor agrees to comply with the General Terms and Conditions; and

WHEREAS, the City desires to provide and install a HVAC System for Spokane City Fire Department Station 1 under the above referenced Ordinance, requiring adding of funds to the original contract;

NOW, THEREFORE, in consideration of these terms, the parties mutually agree as follows:

**1. CONTRACT DOCUMENTS.**

The Contract, dated September 27 and October 5, 2023, any previous amendments, addendums and / or extensions / renewals thereto, are incorporated by reference into this document as though written in full and shall remain in full force and effect except as provided herein.

**2. EFFECTIVE DATE.**

This Contract Amendment shall become effective on November 4, 2024, and shall end September 30, 2026.

**3. COMPENSATION.**

The City shall pay an additional amount not to exceed **THREE HUNDRED TWENTY-NINE THOUSAND THREE HUNDRED TWENTY NO/100 DOLLARS (\$329,320.00)**, plus applicable sales tax, for everything furnished and done under this Contract Amendment. This is the maximum amount to be paid under this Amendment, and shall not be exceeded without the prior written authorization of the City, memorialized with the same formality as the original Contract and this document.

IN WITNESS WHEREOF, in consideration of the terms, conditions and covenants contained, or attached and incorporated and made a part, the parties have executed this Contract Amendment by having legally-binding representatives affix their signatures below.

**ATS INLAND NW, LLC.**

**CITY OF SPOKANE**

By \_\_\_\_\_  
Signature Date

By \_\_\_\_\_  
Signature Date

\_\_\_\_\_  
Type or Print Name

\_\_\_\_\_  
Type or Print Name

\_\_\_\_\_  
Title

\_\_\_\_\_  
Title

Attest:

Approved as to form:

\_\_\_\_\_  
City Clerk

\_\_\_\_\_  
Assistant City Attorney

**Attachments that are part of this Contract:**

Exhibit A - Certification Regarding Debarment

Exhibit B – Contractor – Task Assignment #7 Labor & Installation dated September 23, 2024 and Task Assignment #7 Parts & Equipment dated September 23, 2024

Attachment - ARP/CSLFRF CFDA 21.027

Attachment – General Terms and Conditions

24-212

**EXHIBIT A**

**ATTACHMENT A - CERTIFICATION REGARDING DEBARMENT, SUSPENSION, INELIGIBILITY AND VOLUNTARY EXCLUSION AND FEDERAL FUNDING ACCOUNTABILITY AND TRANSPARENCY ACT (FFATA) CERTIFICATION**

**Certification Regarding Debarment, Suspension, Ineligibility and Voluntary Exclusion**

This certification is required by the regulations implementing Executive Order 12549, Debarment and Suspension, 2 CFR Part 180.

(1) The prospective primary participant certifies to the best of its knowledge and belief that it and its principals:

- (a) Are not presently debarred, suspended, proposed for disbarment, declared ineligible, or voluntarily excluded from covered transactions by any Federal department or agency;
- (b) Have not within a three-year period preceding this application been convicted of or had a civil judgement rendered against them for commission of fraud or a criminal offense in connection with obtaining, attempting to obtain, or performing a public (Federal, State, or local) transaction or contract under a public transaction; violation of Federal or State antitrust statutes or commission of embezzlement, theft, forgery, bribery, falsification or destruction of records, making false statements, tax evasion, receiving stolen property, making false claims, or obstruction of justice;
- (c) Are not presently indicted for or otherwise criminally or civilly charged by a governmental entity (Federal, State, or local) with commission of any of the offenses enumerated in paragraph (1)(b) of this certification; and
- (d) Have not within a three-year period preceding this Agreement had one or more public transactions (Federal, State, or local) terminated for cause or default.

(2) The undersigned agrees by signing this Agreement that it shall not knowingly enter into any lower tier covered transaction with a person who is debarred, suspended, declared ineligible, or voluntarily excluded from participation in this covered transaction.

(3) The undersigned further agrees by signing this Agreement that it will include the following required certification, without modification, in all lower tier covered transactions and in all solicitations for lower tier covered transactions:

Certification Regarding Debarment, Suspension, Ineligibility, and Voluntary Exclusion - Lower Tier Covered Transactions

1. The lower tier contractor certified, by signing this contract that neither it nor its principals is presently debarred, suspended, proposed for debarment, declared ineligible, or voluntarily excluded from participation in this transaction by any Federal department or agency.

(4) The undersigned shall notify the City immediately that if it or a lower tier contractor become debarred, suspended, proposed for debarment, declared ineligible, or voluntarily excluded from covered transactions by any Federal department or agency during the period of performance of this Agreement.

(5) The terms covered transaction, debarred, suspended, ineligible, lower tier covered transaction, person, primary covered transaction, principal, and voluntarily excluded, as used in this exhibit, have the meanings set out in the Definitions and Coverage sections of the rules implementing Executive Order 12549. The undersigned may contact the City for assistance in obtaining a copy of these regulations.

(6) I understand that a false statement of this certification may be grounds for termination of the Agreement.

**By signing this Attachment, the Grantee indicates acceptance of and compliance with all requirements described above.**

ATTACHMENT A - CERTIFICATION REGARDING DEBARMENT, SUSPENSION, INELIGIBILITY AND VOLUNTARY EXCLUSION  
AND FEDERAL FUNDING ACCOUNTABILITY AND TRANSPARENCY ACT (FFATA) CERTIFICATION

**Federal Funding Accountability and Transparency Act (FFATA) Certification**

**The Federal Funding Accountability and Transparency Act (FFATA) seeks to provide the public with greater access to Federal spending information. Due to FFATA requirements, you are required to provide the following information which will be used by the City to comply with federal reporting requirements.**

If certain conditions are met, Grantee must provide names and total compensation of the top five highly compensated Executives. Please answer question 1, and follow the instructions. If directed to question 2, please answer and follow instructions.

1. In Grantee's previous fiscal year, did Grantee receive (a) 80% or more of Grantee's annual gross revenues in U.S. Federal contracts and subcontracts and other Federal financial assistance subject to the Transparency Act, as defined in 2 CFR 170.320; AND (b) \$25,000,000 or more in annual gross revenues from contracts and subcontracts and other Federal financial assistance subject to the Transparency Act, as defined in 2 CFR 170.320?

Yes  If yes, answer question 2 below.

No  If no, stop, you are not required to report names and compensation. Please sign and submit form with the Agreement. \_\_\_\_\_

2. Does the public have access to information about the compensation of Grantee's Executives through periodic reports filed under section 13(a) or 15(d) of the Security Exchange Act of 1934 (15 U.S.C. 78(m)(a), 78o(d)), or section 6104 of the Internal Revenue Code of 1986?

Yes  If yes, stop, you are not required to report names and compensation. Please sign and submit form with the Agreement.

No  If no, you are required to report names and compensation. Please fill out the remainder of this form. \_\_\_\_\_

Please provide the names and Total Compensation of the top five most highly compensated Executives in the space below.

Name:	Total Compensation:
Name:	Total Compensation:
Name:	Total Compensation:
Name:	Total Compensation:
Name:	Total Compensation:

**The Grantee certifies that the information contained on this form is true and accurate.**

**By:**

**Title:**

**Date:**

**EXHIBIT B**



## Task Assignment #7 Labor & Installation

### Fire Station 1 HVAC Control System Replacement

ATS will extend the existing City of Spokane Alerton Compass Control system to include Fire Station 1. System includes control and or monitoring of the following equipment.

Air Handling Units (qty of 2)  
Boiler System with Associated Pumps (qty of 1)  
Domestic Hot Water Heaters (qty of 2)  
Fresh Air Damper Zones (qty of 30)  
Terminal Units (qty of 2)  
Makeup Air Unit (qty of 1) – located in parking garage  
Radiant Heat Zones (qty of 6)  
General Exhaust Fans (typ of 7)  
Parking Garage Exhaust Fans (typ of 2)

### Mechanical System Improvements:

Condensing Units (qty of 2)

- Pre-work air balance to confirm airflow of existing air handling units
- New condensing units
- Removal of existing condensing units
- New refrigerant lines
- New indoor coils
- Sleepers and secondary supports for new condensing units with hot dipped tube steel

Unit Heater (qty of 1)

- Removal of existing
- New unit heater installed in truck bay

Exhaust Fans (qty of 2)

- Removal of existing
- New fans installed in parking garage
- Protective cover installed on exterior housing

**Assumptions / Clarifications**

- 1) Proposal includes system design and installation.
- 2) Proposal pricing for labor and installation. Does not include parts.
- 3) Proposal includes system checkout once the installation is complete to ensure a seamless transition to new software and hardware.
- 4) Proposal includes onsite training on new equipment and controls.
- 5) Proposal assumes that work will occur in a subsequent manner and will not be phased out.
- 6) Proposal assumes existing mechanical equipment that is not being replaced as part of this project is functioning properly.
- 7) Proposal excludes applicable taxes.

- **Pricing for above mentioned project = \$325,050**

**Hourly Rate: \$165**

**Hours Billed: 1,970**

*Pricing valid for period of 60 days from date of proposal.*

**Paul Bonner**

ATS Inland NW

**ATTACHMENT A– ARP/CSLFRF CFDA 21.027 FUNDING**  
American Rescue Plan (ARP)  
Coronavirus State and Local Fiscal Recovery Funds (CSLFRF)  
Funding Authority: U.S. Department of Treasury  
CFDA# 21.027 – Coronavirus State and Local Fiscal Recovery Funds

The Contractor specifically agrees to comply with all applicable state and federal laws, rules, regulations, requirements, program guidance, including but not limited to the following:

All applicable federal, state, and local laws, regulations, executive orders, OMB Circulars, and/or policies including, but not limited to:

Nondiscrimination laws and/or policies, and safety and health regulations.  
Americans with Disabilities Act (ADA), Age Discrimination Act of 1975,  
Title VI of the Civil Rights Act of 1964, Civil Rights Act of 1968,  
Provisions in Buildings for Aged and Handicapped Persons (RCW 70.92).  
Robert T. Stafford Disaster Relief and Emergency Assistance Act (PL 93-288, as amended),  
Ethics in Public Services (RCW 42.52),  
Covenant Against Contingent Fees (48 CFR Section 52.203-5),  
Public Records Act (RCW 42.56),  
Prevailing Wages on Public Works (RCW 39.12),  
State Environmental Policy Act (RCW 43.21C),  
Shoreline Management Act of 1971 (RCW 90.58),  
State Building Code (RCW 19.27),  
Energy Policy and Conservation Act (PL 94-163, as amended),  
Energy Related Building Standards (RCW 19.27A),

Comply with all procurement requirements of 2 CFR Part 200.317 - 200.327. All sole source contracts expected to exceed \$50,000 must be submitted to Spokane City Purchasing for review and approval prior to the award and execution of a contract.

Any contract awarded to the successful Contractor must contain and/or comply with the following procurement provisions in accordance with 2 CFR Part 200.317 - 200.327:

Contractor must maintain a Conflict of Interest Policy consistent with 2 CFR 200.318(c) that is applicable to all activities funded with the award. All potential conflicts of interest related to this award must be reported to Spokane City and/or U.S. Treasury

- Administrative, contractual, or legal remedies in instances where contractors violate or breach contract terms, and provide for such sanctions and penalties as may be appropriate;
- Compliance with Executive Order 11246, “Equal Employment Opportunity,” (30 FR 12319, 12935, 3 CFR Part 1964-1965 Comp., p. 339), as amended by Executive Order 11375, as supplemented in Department of Labor regulations (41 CFR Chapter 60);
- For Capital Expenditures that involve the employment of mechanics of laborers: Compliance with the Contract Work Hours and Safety Standards Act (40 USC 3702 and 3704) as supplemented by Department of Labor Regulations (29 CFR Part 5);
- For all contracts in excess of \$100,000 with respect to water, sewer, or broadband that involve the employment of mechanics of laborers: Compliance with the Contract Work Hours and Safety Standards Act (40 USC 3702 and 3704) as supplemented by Department of Labor Regulations (29 CFR Part 5);
- For construction or repair contracts: Compliance with the Copeland “Anti-Kickback” Act (40 U.S.C. 3145) as supplemented by Department of Labor regulations (29 CFR part 3);
- For construction contracts in excess of \$2,000 when required by Federal grant program legislation:



Compliance with the Davis-Bacon Act (40 U.S.C. 3141-3144 and 3146-3148) as supplemented by Department of Labor regulations (29 CFR part 5); Davis Bacon Act—Does **not** apply to projects funded **solely** with ARPA/CSLFRF CFDA 21.027 funds. However, if other federal funds are also used for the construction project in addition to FRF, and those federal funds require Davis-Bacon compliance, all prime construction contracts in excess of \$2,000 must follow Davis-Bacon Act;

- For construction contracts in excess of \$100,000 that involve the employment of mechanics and laborers: Compliance with the Contract Work Hours and Safety Standard Act (40 U.S.C. 3701-3708) as supplemented by Department of Labor regulations (29 CFR Part 5);
- Compliance with the requirements of 37 CFR Part 401, “Rights to Inventions Made by Nonprofit Organizations and Small Business Firms Under Government Grants, Contracts and Cooperative Agreements,” and any implementing regulations issued by the awarding agency
- For contracts in excess of \$150,000: Compliance with all applicable standards, orders or requirements issued under the Clean Air Act (42 U.S.C. 7401-7671q.) and the Federal Water Pollution Control Act (33 U.S.C. 1251-1387) as amended;
- Compliance with section 6002 of the Solid Waste Disposal Act, as amended by the Resource Conservation and Recovery Act;
- Notice of awarding agency requirements and regulations pertaining to reporting;
- Federal awarding agency requirements and regulations pertaining to copyrights and rights in data;
- Access by Spokane City, the Federal awarding agency, the Comptroller General of the United States, or any of their duly authorized representatives to any books, documents, papers and records, sub-agreements, leases, subcontracts, arrangements, or other third-party agreements of any type, and supporting materials related to those records of the Contractor, which are directly pertinent to that specific contract for the purpose of making audit, examination, excerpts and transcriptions;
- Retention of all required records for **six years** after Spokane City makes final payment and all other pending matters are closed;
- Mandatory standards and policies relating to energy efficiency which are contained in the state energy conservation plan issued in compliance with the Energy Policy and Conservation Act (Pub. L. 94-163, 89 Stat. 871);
- Notice of awarding agency requirements and regulations governing the development, reporting, and disposition of rights to inventions and patents resulting from financial assistance awards (37 C.F.R. Part 401) and the standard patent rights clause (37 C.F.R. section 401.14);
- Compliance with Executive Order 13858 “Strengthening Buy-American Preferences for Infrastructure Projects” as appropriate and to the extent consistent with law; and
- Compliance with 2 C.F.R. § 200.216, prohibitions regarding certain telecommunications and video surveillance services or equipment are mandated by section 889 of the John S. McCain National Defense Authorization Act for Fiscal Year 2019 (FY 2019 NDAA), Pub. L. No. 115-232 (2018).

Any contract awarded to the successful Contractor must contain and/or comply with the following provisions in accordance with 2 CFR Part 200.332(a) - 200.332(a)(1)-200.332(a)(6) Requirements for pass-through entities:

- Identify as a Subaward (2 CFR 200.332(a));
- Federal Award Identification (2 CFR 200.332(a)(1));
- Terms and conditions from ARP/CLFRF (2 CFR 200.332(a)(2));
- Additional City of Spokane imposed requirements based on risk assessment (2 CFR 200.332(a)(3));
- Indirect cost rate (2 CFR 200.332(a)(4));
- Records access & retention (2 CFR 200.332(a)(5));
- Closeout provisions (2 CFR 200.332(a)(6)).

Any contract awarded to the successful Contractor must contain and/or comply with the following provisions in accordance with 2 CFR Part 200.501(a)-200.501(h) Audit Requirements:

- Audit required. A non-Federal entity that expends \$750,000 or more during the non-Federal entity's fiscal year in Federal awards must have a single or program-specific audit conducted for that year in accordance with the provision of this part (2 CFR 200.501(a));
- Single Audit (2 CFR 200.501(b));
- Program-specific audit election (2 CFR 200.501(c));
- Exemption when Federal awards expended are less than \$750,000(2 CFR 200.501(d));
- Federally Funded Research and Development Centers (2 CFR 200.501(e));
- Subrecipients and contractors (2 CFR 200.501(f));
- Compliance responsibility for contractors (2 CFR 200.501(g));
- For-profit subrecipient (2 CFR 200.501(h)).

Contractor must comply with Executive Orders 12549 and 12689 and 2 C.F.R. Part 180, which restrict awards, subawards, and contracts with certain parties that are debarred, suspended, or otherwise excluded from or ineligible for participation in federal assistance programs or activities. Contractor must certify that it is not presently debarred, suspended or proposed for debarment, declared ineligible, or voluntarily excluded from participating in this Agreement by any federal department or agency.

Contractor must comply with the requirements of 31 U.S.C. § 3729-3733 which prohibits the submission of false or fraudulent claims for payment to the Federal Government. See also 31 U.S.C. § 3801-3812 which details the administrative remedies for false claims and statements made.

Contractor is required to be non-delinquent in their repayment of any Federal debt. Examples of relevant debt include delinquent payroll and other taxes, audit disallowances, and benefit overpayments. See OMB Circular A-129.

Contractor's costs must be compliant with 2 CFR Part 200 Subpart E Cost Principles.

Contractor must comply with 31 U.S.C. § 1352, which provides that none of the funds provided under an award may be expended by the recipient to pay any person to influence, or attempt to influence an officer or employee of any agency, Member of Congress, an officer, or employee of Congress, or an employee of a Member of Congress in connection with any Federal action concerning an award, making of any federal grant, federal loan, continuation, renewal, amendment or modification of any federal contract, grant loan, or cooperative agreement, and that if any funds other than federal appropriated funds have been paid or will be paid to any person for influencing or attempting to influence an officer or employee of any agency, a Member of Congress, an officer or employee of Congress, or an employee of a Member of Congress in connection with this award, the Contractor will complete and submit Standard Form-LLL, "Disclosure Form to Report Lobbying," in accordance with its instructions.

In the event of the Contractor's noncompliance or refusal to comply with any applicable law, regulation, executive order, OMB Circular or policy, Spokane City may rescind, cancel, or terminate the contract in whole or in part in its sole discretion. The Contractor is responsible for all costs or liability arising from its failure to comply with applicable laws, regulations, executive orders, OMB Circulars, or policies.

## CERTIFICATION

\_\_\_\_\_  
Signature, Administrator, or Applicant Agency

\_\_\_\_\_  
Date

\_\_\_\_\_  
print name and title

## **General Terms & Conditions**

### **1. CONTRACTING WITH CURRENT OR FORMER CITY EMPLOYEES**

Specific restrictions apply to contracting with current or former City officers and employees pursuant to the Code of Ethics in chapter 1.04A of the Spokane Municipal Code. Proposers shall familiarize themselves with the requirements prior to submitting a Proposal that includes current or former City officers or employees.

### **2. PROPRIETARY INFORMATION / PUBLIC DISCLOSURE**

All materials submitted to the City in responses to this competitive procurement shall become the property of the City.

All materials received by the City are public records and are subject to being released pursuant to a valid public records request. Washington state law mandates that all documents used, received or produced by a governmental entity are presumptively public records, and there are few exemptions. Chapter 41.56 RCW.

When responding to this competitive procurement, please consider that what you submit will be a public record. If you believe that some part of your response constitutes legally protected proprietary information, you MUST submit those portions of your response as a separate part of your response, and you MUST label it as "PROPRIETARY INFORMATION." If a valid public records request is then received by the City for this information, you will be given notice and a 10-day opportunity to go to court to obtain an injunction to prevent the City from releasing this part of your response. If no injunction is obtained, the City is legally required to release the records.

The City will neither look for nor honor any claims of "proprietary information" that are not within the separate part of your response.

### **3. OWNERSHIP OF DOCUMENTS**

Any and all data, reports, analyses, documents, photographs, pamphlets, plans, specifications, surveys, films or any other material created, prepared, produced, constructed, assembled, made, performed or otherwise produced by the Firm or the Firm's subcontractors or consultants for delivery to the City under this Agreement shall be the sole and absolute property of the City. Such property shall constitute "work made for hire" as defined by U.S. Copyright Act of 1976, 17 U.S.C. § 101, and the ownership of the copyright and any other intellectual property rights in such property shall vest in the City at the time of its creation. Ownership of the intellectual property includes the right to copyright, patent, and register, and the ability to transfer these rights. Material which the Firm uses to perform this Agreement, but is not created, prepared, constructed, assembled, made, performed or otherwise produced for, or paid for, by the City is owned by the Firm and is not "work made for hire" within the terms of this Agreement.

### **4. ACCEPTANCE PERIOD**

Proposals shall remain in effect for ninety (90) days for acceptance by the City from the due date for receipt of Proposals.

### **5. COSTS TO PROPOSE**

The City will not be liable for any costs incurred by the Proposer in preparation of a Proposal submitted in response to this RFP, in conduct of a presentation, or any other activities related to responding to this RFP.

## **6. INTERLOCAL PURCHASE AGREEMENTS**

The City of Spokane has entered into Interlocal Purchase Agreements with other public agencies pursuant to Chapter 39.34 RCW. In submitting a response, the Proposer agrees to provide its services to other public agencies at the same contracted price, terms and conditions it is providing to the City of Spokane, contingent upon the Firm's review and approval at the time of a requested contract. The Firm's right to refuse to enter into a contract with another public agency at the time of request shall be absolute.

## **7. DEBRIEFING OF UNSUCCESSFUL PROPOSERS**

Upon request, a debriefing conference will be scheduled with an unsuccessful Proposer. Discussion will be limited to a critique of the requesting Firm's Proposal. Debriefing conferences may be conducted in person or on the telephone.

## **8. MINORITY & WOMEN-OWNED BUSINESS PARTICIPATION**

The City encourages participation in all of its contracts by Firms certified by the Washington State Office of Minority and Women's Business Enterprises (OMWBE). Proposers may contact OMWBE at (360)753-9693 to obtain information on certified Firms.

## **9. NONDISCRIMINATION**

No individual shall be excluded from participation in, denied the benefit of, subjected to discrimination under, or denied employment in the administration of or in connection with this Contract because of age, sex, race, color, religion, creed, marital status, familial status, sexual orientation including gender expression or gender identity, national origin, honorably discharged veteran or military status, the presence of any sensory, mental or physical disability, or use of a service animal by a person with disabilities. The Firm agrees to comply with, and to require that all subcontractors comply with, Section 504 of the Rehabilitation Act of 1973 and the Americans with Disabilities Act, as applicable to the Firm.

## **10. BUSINESS REGISTRATION REQUIREMENT**

Section 8.01.070 of the Spokane Municipal Code states that no person may engage in business with the City without first having obtained and currently being the holder of a valid annual business registration or temporary business registration as provided in this chapter. The Firm shall be responsible for contacting the State of Washington Business License Services at <http://dor.wa.gov> or 1-360-705-6741 to obtain a business registration. If the Firm does not believe it is required to obtain a business registration, it may contact the City's Taxes and Licenses Division at 509-625-6070 to request an exemption status determination.

## **11. PAYMENT**

Payment will be made via direct deposit/ACH except as provided by state law. A completed ACH application is required before a City Order will be issued. If the City objects to all or any portion of the invoice, it shall notify the Company and reserves the right to only pay that portion of the invoice not in dispute. In that event, the parties shall immediately make every effort to settle the disputed amount.

## **12. ANTI-KICKBACK**

No officer or employee of the City of Spokane, having the power or duty to perform an official act or action related to this contract shall have or acquire any interest in the contract, or have solicited,

accepted or granted a present or future gift, favor, service or other thing of value from or to any person involved in the contract.

### **13. DISPUTES**

This contract shall be performed under the laws of Washington State. Any litigation to enforce this contract or any of its provisions shall be brought in Spokane County, Washington.

### **14. TERMINATION**

- A. For Cause: The City or Consultant may terminate the Agreement if the other party is in material breach of this Agreement, and such breach has not been corrected to the other party's reasonable satisfaction in a timely manner. Notice of termination under this Section shall be given by the party terminating this Agreement to the other, not fewer than thirty (30) business days prior to the effective date of termination.
- B. For Reasons Beyond Control of Parties: Either party may terminate this Agreement without recourse by the other where performance is rendered impossible or impracticable for reasons beyond such party's reasonable control, such as, but not limited to, an act of nature, war or warlike operation, civil commotion, riot, labor dispute including strike, walkout or lockout, except labor disputes involving the Consultant's own employees, sabotage, or superior governmental regulation or control. Notice of termination under this Section shall be given by the party terminating this Agreement to the other, not fewer than thirty (30) business days prior to the effective date of termination.
- C. For Convenience: Either party may terminate this Agreement without cause, upon thirty (30) days written notice to the other party.
- D. Actions upon Termination: if termination occurs not the fault of the Consultant, the Consultant shall be paid for the services properly performed prior to the actual termination date, with any reimbursable expenses then due, but such compensation shall not exceed the maximum compensation to be paid under the Agreement. The Consultant agrees this payment shall fully and adequately compensate the Consultant and all subconsultants for all profits, costs, expenses, losses, liabilities, damages, taxes, and charges of any kind (whether foreseen or unforeseen) attributable to the termination of this Agreement.
- E. Upon termination, the Consultant shall provide the City with the most current design documents, contract documents, writings, and other products the Consultant has produced to termination, along with copies of all project-related correspondence and similar items. The City shall have the same rights to use these materials as if termination had not occurred; provided however, that the City shall indemnify and hold the Consultant harmless from any claims, losses, or damages to the extent caused by modifications made by the City to the Consultant's work product.

### **15. LIABILITY**

The Firm shall indemnify, defend, and hold harmless the City, its officers, and employees from all claims, demands, or suits in law or equity arising from the Firm's negligence or breach or its obligations under the contract. The Firm's duty to indemnify shall not apply to liability caused by the sole negligence of the City, its officers, and employees. The Firm's duty to indemnify for liability arising from the concurrent negligence of the City, its officers and employees and the Firm, its officers and employees shall apply only to the extent of the negligence of the Firm, its officers and employees. The Firm's duty to indemnify shall survive

termination or expiration of the contract. The Firm waives, with respect to the City only, its immunity under RCW Title 51, Industrial Insurance.

## **16. INSURANCE COVERAGE**

During the term of the contract, the Firm shall maintain in force at its own expense, each insurance coverage noted below:

- A. Worker's Compensation Insurance in compliance with RCW 51.12.020, which requires subject employers to provide workers' compensation coverage for all their subject workers and Employer's Liability Insurance in the amount of \$1,000,000.
- B. General Liability Insurance on an occurrence basis, with a combined single limit of not less than \$1,000,000 each occurrence for bodily injury and property damage. It shall include contractual liability coverage for the indemnity provided under this contract. It shall provide that the City, its officers and employees are additional insureds, but only with respect to the Firm's services to be provided under this contract.
- C. Automobile Liability Insurance with a combined single limit, or the equivalent of not less than \$1,000,000 each accident for bodily injury and property damage, including coverage for owned, hired and non-owned vehicles.
- D. Professional Liability Insurance with a combined single limit of not less than \$1,000,000 each claim, incident, or occurrence. This is to cover damages caused by the error, omission, or negligent acts related to the professional services to be provided under this contract. The coverage must remain in effect for at least three (3) years after the contract is completed.

There shall be no cancellation, material change, reduction of limits or intent not to renew the insurance coverage(s) without forty-five (45) days written notice from the Firm or its insurer(s) to the City.

As evidence of the insurance coverages required by this contract, the Firm shall furnish acceptable insurance certificates to the City at the time it returns the signed contract. The certificate shall specify all of the parties who are additional insured, and include applicable policy endorsements, and the deductible or retention level, as well as policy limits. Insuring companies or entities are subject to City acceptance and must have a rating of A- or higher by Best. Copies of all applicable endorsements shall be provided. The Firm shall be financially responsible for all pertinent deductibles, self-insured retentions, and/or self-insurance.

## **SPECIFIC GRANT RELATED LANGUAGE**

### **17. CERTIFICATION REGARDING DEBARMENT, SUSPENSION, INELEGIBILITY AND VOLUNTARY EXCLUSION**

A certification form will accompany the contract to be signed confirming that, to the best of its knowledge and belief, Firm, and its principals:

- A. Are not presently debarred, suspended, proposed for debarment, declared ineligible, or voluntarily excluded from covered transactions by any federal department or agency.
- B. Have not within a three-year period preceding this contract been convicted or had a civil judgment rendered against them for commission of fraud or a criminal offense in connection with obtaining, attempting to obtain, or performing a public (federal, state, or local) transaction or contract under a public transaction; violation of federal or state antitrust statutes or commission of embezzlement, theft, forgery, bribery, falsification or destruction of records, making false statements, tax evasion, receiving stolen property, making false claims, or obstruction of justice.

- C. Are not presently indicted or otherwise criminally or civilly charged by a government entity (federal, state, or local) with commission of any of the offenses enumerated in paragraph (1)(b) of this certification.
- D. Have not within a three-year period preceding this contract had one or more public transactions (federal, state, or local) terminated for cause or default.

**18. CERTIFICATION REGARDING LOBBYING**

Byrd Anti-Lobbying Amendment (31 U.S.C. 1352) – Firms who apply or bid for an award of \$100,000 or more shall file the required certification. Each tier certifies to the tier above that it will not and has not used Federal appropriated funds to pay any person or organization for influencing or attempting to influence an officer or employee of any agency, a member of Congress, officer or employee of Congress, or an employee of a member of Congress in connection with obtaining any Federal contract, grant or any other award covered by 31 U.S.C. 1352. Each tier shall also disclose any lobbying in non-Federal funds that takes place in connection with obtaining any Federal award. Such disclosures are forwarded from tier to tier up to the recipient.

A Certification Form is attached and included in this Request for Proposal by reference as Attachment A “Certification Regarding Lobbying”. The Proposer is required to sign and submit this Form with Proposal. The Proposer certifies by signing and submitting this Proposal, to the best of his or her knowledge and belief, that:

- A. No Federal appropriated funds have been paid or will be paid, by or on behalf of the undersigned, to any person for influencing or attempting to influence an officer or employee of any Federal agency, a Member of Congress, an officer or employee of Congress, or any employee of a Member of Congress in connection with the awarding of any Federal grant, the making of any Federal loan, the entering into of any cooperative agreement, and the extension, continuation, renewal, amendment or modification of any Federal contract, grant, loan, or cooperative agreement.
- B. If any funds other than Federal appropriated funds have been paid or will be paid to any person for influencing or attempting to influence an officer or employee of any Federal agency, a Member of Congress, an officer or employee of Congress, or an employee of a Member of Congress in connection with this Federal contract, grant, loan, or cooperative agreement, the undersigned shall complete and submit Standard Form-LLL, "Disclosure of Lobbying Activities," in accordance with its instructions.
- C. The Proposer also agrees by submitting his or her Proposal, that he or she shall require that the language of this certification be included in all lower tier subcontracts. Which exceed \$100,000 and that all such sub-recipients shall certify and disclose accordingly.
- D. This certification is a material representation of fact upon which reliance was placed when this transaction was made or entered into. Submission of this certification is a prerequisite for making or entering into this transaction imposed by section 1352, title 31, United States Code. Any person who fails to file the required certification shall be subject to a civil penalty of not less than \$10,000 and not more than \$100,000 for each such failure.

**19. DOMESTIC PREFERENCE**

200.322 (a) As appropriate and to the extent consistent with law, the non-Federal entity should to the greatest extent practicable under a Federal award, provide a preference for the purchase, acquisition, or use of goods, products, or materials produced in the United States (including but not limited to iron, aluminum, steel, cement, and other manufactured products).

## **20. CLEAN AIR ACT**

Clean Air Act (42 U.S.C. 7401 et seq.) and the Federal Water Pollution Control Act (33 U.S.C. 1251 et seq.), as amended – Firms and subgrants of amounts in excess of \$100,000 shall contain a provision that requires the recipient to agree to comply with all applicable standards, orders or regulations issued pursuant to the Clean Air Act (42 U.S.C. 7401 et seq.) and the Federal Water Pollution Control Act as amended (33 U.S.C. 1251 et seq.) Violations shall be reported to the Federal awarding agency and the Regional Office of the Environmental Protection Agency (EPA).

## **21. CONFORMANCE WITH FEDERAL, STATE, AND LOCAL LAWS**

Federal, State and Local Laws: Services of a project as a result of the use of a Firm's services including the letting of subcontracts in connection with any project work related to this RFQ may be required to conform to the applicable requirements of Federal, State and local laws and ordinances. The City stipulates that Federal funds may be involved.

## **22. MAINTENANCE OF RECORDS**

Federal, State and Local Laws: Services of a project as a result of the use of a Firm's services including the letting of subcontracts in connection with any project work related to this RFQ may be required to conform to the applicable requirements of Federal, State and local laws and ordinances. The City stipulates that Federal funds may be involved.

## **23. CONFERENCE ROOMS**

Conference Rooms: All space used for conferences, meetings, conventions, or training seminars funded in whole or in part with federal funds under this contract must comply with the protection and controlling guidelines of the Hotel and Motel Fire Safety Act (PL 101-391, as amended).

## **24. AMERICANS WITH DISABILITIES ACT INFORMATION (ADA)**

Americans with Disabilities Act (42 U.S.C. 12101, et seq.). The Applicant shall comply with the provisions of the Americans with Disabilities Act, 42 U.S.C. 12101, et. seq. That Act provides a comprehensive national mandate to eliminate discrimination against individuals with disabilities. The Act may impose requirements on the Applicant in four principle ways: 1) with respect to employment; 2) with respect to the provision of public services; 3) with respect to transportation; 4) with respect to existing facilities and new construction.

The City in accordance with Section 504 of the Rehabilitation Act of 1973 and the Americans with Disabilities Act (ADA) commits to nondiscrimination in all of its programs and activities. The Firm agrees to comply with, and to require that all subcontractors comply with, Section 504 of the Rehabilitation Act of 1973 and the Americans with Disabilities Act, as applicable to the Firm.

Law Against Discrimination, Chapter 49.60 RCW. The Applicant shall comply with the provisions of Chapter 49.60 RCW in all activities relating to this Grant Agreement.

This material can be made available in an alternate format by request through ProcureWare question tab or by calling (509) 625-6400.



## **25. TITLE VI STATEMENT**

The City of Spokane in accordance with Title VI of the Civil Rights Act of 1964, 78 Stat. 252, 42 USC 2000d to 2000d-4 and Title 49, Code of Federal Regulations, Department of Transportation, Subtitle A, Office of the Secretary, Part 21, Nondiscrimination in Federally-Assisted Programs of the Department of Transportation issued pursuant to such Act, hereby notifies all Proposers that it will affirmatively ensure that in any contract entered into pursuant to this advertisement, disadvantaged business enterprises as defined at 49 CFR Part 26 will be afforded full opportunity to submit Proposals in response to this invitation and will not be discriminated against on the grounds of race, color, national origin, or sex in consideration for an award.

Public Law 88 - 352, Title VI of the Civil Rights Act of 1964 (42 U.S.C. 2000d et seq.) (24 CFR Part 1). The Applicant must comply with the provisions of "Public Law 88 - 352," which refers to Title VI of the Civil Rights Act of 1964 (42 U.S.C. 2000d et seq.). The law provides that no person in the United States shall, on the grounds of race, color or national origin, be denied the benefits of, be excluded from participation in, or be subjected to discrimination under any program or activity receiving federal financial assistance.



**License Information:**

[New search](#) [Back to results](#)

**Entity name:** ATS INLAND NW LLC

**Business name:** ATS INLAND NW LLC

**Entity type:** [Limited Liability Company](#)

**UBI #:** 602-410-090

**Business ID:** 001

**Location ID:** 0001

**Location:** Active

**Location address:** 9507 E SPRAGUE AVE  
SPOKANE VALLEY WA 99206-3616

**Mailing address:** 450 SHATTUCK AVE S  
RENTON WA 98057-2427

**Excise tax and reseller permit status:** [Click here](#)

**Secretary of State status:** [Click here](#)

**Endorsements**

Endorsements held at this location	License #	Count	Details	Status	Expiration date	First issuance date
<a href="#">Moses Lake General Business - Non-Resident</a>	BUS2015-10232			Active	Jul-31-2025	Jul-13-2015
<a href="#">Spokane General Business - Non-Resident</a>	T12032728BUS			Active	Jul-31-2025	Oct-15-2012
<a href="#">Spokane Valley General Business</a>				Active	Jul-31-2025	May-23-2014

**Governing People** May include governing people not registered with Secretary of State

Governing people	Title
ALLEN, BRIAN	
KISSINGER, WILLIAM	

**Registered Trade Names**

Registered trade names	Status	First issued
ATS INLAND NW LLC	Active	Jan-31-2017

The Business Lookup information is updated nightly. Search date and time: 10/10/2024 9:05:21 AM



How are we doing?  
**Take our survey!**

Don't see what you expected?  
**Check if your browser is supported**







**Agenda Sheet for City Council:**

**Committee:** PIES **Date:** 10/21/2024

**Committee Agenda type:** Consent

**Date Rec'd** 10/22/2024

**Clerk's File #** OPR 2024-0939

**Cross Ref #**

**Project #**

**Council Meeting Date:** 11/04/2024

<b>Submitting Dept</b>	FACILITIES MANAGEMENT	<b>Bid #</b>	IPWQ #6225-24
------------------------	-----------------------	--------------	---------------

<b>Contact Name/Phone</b>	DAVE STEELE 625-6064	<b>Requisition #</b>	CR26801
---------------------------	----------------------	----------------------	---------

<b>Contact E-Mail</b>	DSTEEL@SPOKANECITY.ORG		
-----------------------	------------------------	--	--

<b>Agenda Item Type</b>	Contract Item		
-------------------------	---------------	--	--

<b>Council Sponsor(s)</b>	BWILKERSON JBINGLE KKLITZKE		
---------------------------	-----------------------------	--	--

<b>Agenda Item Name</b>	5900 FACILITIES DEPARTMENT WEST CENTRAL COMM CENTER FOUNTAIN		
-------------------------	--	--	--

**Agenda Wording**

The Facilities Department in partnership with the West Central CC and Purchasing Department has selected a local contractor, Bozco Construction, 9616 E. Little Deep Creek Rd, Colbert WA to complete the removal & reconstruction of the water Fountain.

**Summary (Background)**

The Facilities Department in partnership with the West Central Community Center has selected a contractor (Bozco Construction, 9616 E. Little Deep Creek Rd, Colbert, WA) to complete the removal and reconstruction of the existing decorative water feature in the West Central Community Center interior plaza. The low base bid is \$67,900 before sales tax. We are also requesting an administrative reserve of 10% for \$6,790 be approved.

Lease? NO Grant related? NO Public Works? YES

**Fiscal Impact**

Approved in Current Year Budget?

Total Cost	\$ 74,011
------------	-----------

Current Year Cost	\$ 74,011
-------------------	-----------

Subsequent Year(s) Cost	\$ 0
-------------------------	------

**Narrative**

This is the base bid of \$67,900 plus the 10% administrative reserve of \$6,790.

**Amount**

**Budget Account**

Expense	\$ 74,011	# 1425-88153-94000-56301-97243
Expense	\$ 6,790	# Admin Reserve; not encumbered
Select	\$	#
Select	\$	#
	\$	#
	\$	#



**Continuation of Wording, Summary, Approvals, and Distribution**

**Agenda Wording**

**Summary (Background)**

**Approvals**

<b><u>Dept Head</u></b>	TEAL, JEFFREY
<b><u>Division Director</u></b>	BOSTON, MATTHEW
<b><u>Accounting Manager</u></b>	BUSTOS, KIM
<b><u>Legal</u></b>	SCHOEDEL, ELIZABETH
<b><u>For the Mayor</u></b>	PICCOLO, MIKE

**Additional Approvals**

<b><u>PURCHASING</u></b>	PRINCE, THEA

**Distribution List**

bozco@q.com ; petebozin@gmail.com	dsteELE@spokanecity.org
facilitiesdepartment@spokanecity.org	laga@spokanecity.org
kbustos@spokanecity.org	mmurray@spokanecity.org
TPRINCE@SPOKANECITY.ORG	

## Committee Agenda Sheet

### Public Infrastructure, Environment & Sustainability Committee

<b>Submitting Department</b>	Facilities Department
<b>Contact Name</b>	Dave Steele
<b>Contact Email &amp; Phone</b>	509-625-6064
<b>Council Sponsor(s)</b>	CM Cathcart, CP Wilkerson, CM Zappone
<b>Select Agenda Item Type</b>	<input checked="" type="checkbox"/> Consent <input type="checkbox"/> Discussion    Time Requested:
<b>Agenda Item Name</b>	West Central Community Center – Fountain
<b>Summary (Background)</b>  *Use the Fiscal Impact box below for relevant financial information	The Facilities Department in partnership with the West Central Community Center has selected a contractor (BOZCO Construction, 9616 East Little Deep Creek Road, Colbert Rd. WA) to complete the removal and reconstruction of the existing decorative water feature in the West Central Community Center interior plaza. The low base bid before tax was \$67,900 before applicable sales tax. We are also requesting an administrative reserve of 10% for \$6,790 be approved.
<b>Proposed Council Action</b>	Contract approval
<b>Fiscal Impact</b>	
Total Expense:	<b>\$ 74,690 Plus Applicable Tax</b>
<b>Base bid:</b>	<b>\$ 67,900</b>
<u>Administrative Reserve (10%)</u>	<u>6,790</u>
Total:	<b>\$ 74,690 Plus Applicable Tax</b>
Approved in current year budget? <input checked="" type="checkbox"/> Yes <input type="checkbox"/> No <input type="checkbox"/> N/A	
Funding Source <input checked="" type="checkbox"/> One-time <input type="checkbox"/> Recurring <input type="checkbox"/> N/A	
Specify funding source:    ARPA <u>1425-88153-94000-56301-97243</u>	
Expense Occurrence <input checked="" type="checkbox"/> One-time <input type="checkbox"/> Recurring <input type="checkbox"/> N/A	
<b>Operations Impacts (If N/A, please give a brief description as to why)</b>	
What impacts would the proposal have on historically excluded communities?	
The Community Center directly serves a variety of excluded communities with a wide range of programs, day care, etc.	

How will data be collected, analyzed, and reported concerning the effect of the program/policy by racial, ethnic, gender identity, national origin, income level, disability, sexual orientation, or other existing disparities?

NA

How will data be collected regarding the effectiveness of this program, policy, or product to ensure it is the right solution?

NA

Describe how this proposal aligns with current City Policies, including the Comprehensive Plan, Sustainability Action Plan, Capital Improvement Program, Neighborhood Master Plans, Council Resolutions, and others?

NA





**City of Spokane**  
**PUBLIC WORKS AGREEMENT**  
**Title: WEST CENTRAL COMMUNITY CENTER  
DEMOLITION AND REPLACEMENT OF  
COURTYARD WATER FEATURE**

This Agreement is made and entered into by and between the **CITY OF SPOKANE** as (“City”), a Washington municipal corporation, and **BOZCO CONSTRUCTION, LLC**, whose address is P.O. Box 662, Mead, Washington 99021, as (“Contractor”), individually hereafter referenced as a “party”, and together as the “parties”.

*WHEREAS, the Contractor was selected from IPWQ 6225-24 issued by the City; and*

*Whereas the City is authorized to expend ARPA funds for this contract in accordance with Ordinance C36246, passed 8/1/2022 (section 1. (A) ) and;*

*WHEREAS, the Contractor agrees to comply with the attached ARP/CSLFRF CFDA 21.027 General Terms and Conditions.*

NOW, THEREFORE, in consideration of these terms, the parties mutually agree as follows:

1. **PERFORMANCE.** The Contractor will do all work, furnish all labor, materials, tools, construction equipment, transportation, supplies, supervision, organization and other items of work and costs necessary for the proper execution and completion of the work described in the specifications entitled **West Central Community Center Demolition and Replacement of Courtyard Water Feature.**
2. **CONTRACT DOCUMENTS.** The contract documents are this Contract, IPWQ 6225-24, the Contractor’s Response to IPWQ 6225-24 which is attached as Exhibit B, unit price bid forms, contract provisions, contract plans & specifications & appendices, standard specifications, standard plans, addenda, various certifications and affidavits, supplemental agreements, change orders, subsurface boring logs (if any), and ARP/CSLFRF CFDA 21.027. In the event of a conflict between these documents, this Contract shall be used to determine prevailing contract document. These contract documents are on file in the Facilities Department and are incorporated into this Contract by reference as if they were set forth at length. In the event of a conflict, or to resolve an ambiguity or dispute, federal and state requirements supersede this Contract, and this Contract supersedes the other contract documents.
3. **TIME OF PERFORMANCE.** The time of performance of the Contract shall begin on November 11, 2024, and shall run through October 31, 2025. Project time of completion and

working days in accordance with contract documents.

4. LIQUIDATED DAMAGES. Liquidated damages shall be in accordance with the contract documents.

5. TERMINATION. Either party may terminate this Contract by thirty (30) days written notice to the other party. In the event of such termination, the City shall pay the Contractor for all work previously authorized and performed prior to the termination date.

6. COMPENSATION. Total compensation for Contractor's services under this Contract shall be a maximum amount not to exceed **SIXTY SEVEN THOUSAND NINE HUNDRED AND NO/100 DOLLARS (\$67,900.00)**, plus applicable taxes, unless modified by a written amendment to this Contract. This is the maximum amount to be paid under this Contract for the work described in Section 2 above, and shall not be exceeded without the prior written authorization of the City in the form of an executed amendment to this Contract.

7. PAYMENT. The Contractor will send its applications for payment to the City of Spokane Facilities Management Department, facilitiesdepartment@spokanecity.org, Attn: Dave Steele. All invoices should include the Department Contract No. "OPR XXXX-XXXX" and an approved L & I Intent to Pay Prevailing Wage number. The final invoice should include an approved Affidavit of Wages Paid number. Payment will not be made without this documentation included on the invoice. **Payment will be made via direct deposit/ACH** within thirty (30) days after receipt of the Company's application except as provided by state law.

6. STATEMENT OF INTENT TO PAY PREVAILING WAGES TO BE POSTED.

The Contractor and each subcontractor required to pay the prevailing rate of wages shall post in a location readily visible at the job site: (1) a copy of a "Statement of Intent to Pay Prevailing Wages" approved by the industrial statistician of the Washington State Department of Labor and Industries (L & I); and (2) the address and telephone number of the industrial statistician of the Department of Labor and Industries where a complaint or inquiry concerning prevailing wages may be made.

7. STATE PREVAILING WAGES. The Contractor and all subcontractors will submit a "Statement of Intent to Pay Prevailing Wages" certified by the industrial statistician of the Department of Labor and Industries, prior to any payments. The "Statement of Intent to Pay Prevailing Wages" shall include: (1) the Contractor's registration number; and (2) the prevailing wages under RCW 39.12.020 and the number of workers in each classification. Each voucher claim submitted by the Contractor for payment on a project estimate shall state that the prevailing wages have been paid in accordance with the "Statement(s) of Intent to Pay Prevailing Wages" on file with the City. Prior to the payment of funds held under RCW 60.28, the Contractor and subcontractors must submit an "Affidavit of Wages Paid" certified by the industrial statistician.

8. BONDS. The Contractor may not commence work until it obtains all insurance, permits and bonds required by the contract documents and applicable law. This includes the execution of a payment / performance bond on the form attached, equal to one hundred percent (100%) of the contract price and written by a corporate surety company licensed to do business in Washington State.

9. PUBLIC WORKS REQUIREMENTS. The Contractor and each subcontractor are required to fulfill the Department of Labor and Industries Public Works and Prevailing Wage Training Requirement under RCW 39.04.350. The contractor must verify responsibility criteria for each first tier subcontractor, and a subcontractor of any tier that hires other subcontractors must verify the responsibility criteria listed in RCW 39.04.350(1) for each of its subcontractors. Verification shall include that each subcontractor, at the time of subcontract execution, meets the responsibility criteria. This verification requirement, as well as responsibility criteria, must be included in every public works contract and subcontract of every tier.

10. INDEMNIFICATION. The Contractor shall defend, indemnify, and hold the City and its officers and employees harmless from all claims, demands, or suits at law or equity asserted by third parties for bodily injury (including death) and/or property damage which arise from the Contractor's negligence or willful misconduct under this Agreement, including attorneys' fees and litigation costs; provided that nothing herein shall require a Contractor to indemnify the City against and hold harmless the City from claims, demands or suits based solely upon the negligence of the City, its agents, officers, and employees. If a claim or suit is caused by or results from the concurrent negligence of the Contractor's agents or employees and the City, its agents, officers and employees, this indemnity provision shall be valid and enforceable to the extent of the negligence of the Contractor, its agents or employees. The Contractor specifically assumes liability and agrees to defend, indemnify, and hold the City harmless for actions brought by the Contractor's own employees against the City and, solely for the purpose of this indemnification and defense, the Contractor specifically waives any immunity under the Washington State industrial insurance law, or Title 51 RCW. The Contractor recognizes that this waiver was specifically entered into pursuant to the provisions of RCW 4.24.115 and was the subject of mutual negotiation. The indemnity and agreement to defend and hold the City harmless provided for in this section shall survive any termination or expiration of this agreement.

11. INSURANCE. During the period of the Contract, the Contractor shall maintain in force at its own expense, each insurance noted below with companies or through sources approved by the State Insurance Commissioner pursuant to Title 48 RCW:

A. Worker's Compensation Insurance in compliance with RCW 51.12.020, which requires subject employers to provide workers' compensation coverage for all their subject workers and Employer's Liability Insurance in the amount of \$1,000,000;

B. General Liability Insurance on an occurrence basis, with a combined single limit of not less than \$1,000,000 each occurrence for bodily injury and property damage. It shall include contractual liability coverage for the indemnity provided under this Contract. It shall provide that the City, its officers and employees are additional insureds but only with respect to the Contractor's services to be provided under this Contract;

i. Acceptable supplementary Umbrella coverage in combination with Commercial General Liability policy shall be a minimum of \$2M in order to meet the minimum insurance coverages required under this contract; and

C. Automobile Liability Insurance with a combined single limit, or the equivalent of not less than \$1,000,000 each accident for bodily injury and property damage, including coverage for owned, hired and non-owned vehicles; and

D. Property Insurance if materials and supplies are furnished by the Contractor. The amount of the insurance coverage shall be the value of the materials and supplies of the completed value of improvement. Hazard or XCU (explosion, collapse, underground) insurance should be provided if any hazard exists.

There shall be no cancellation, material change, reduction of limits or intent not to renew the insurance coverage(s) without thirty (30) days written notice from the Consultant or its insurer(s) to the City. As evidence of the insurance coverage(s) required by this Agreement, the Consultant shall furnish acceptable Certificates of Insurance (COI) to the City at the time it returns this signed Agreement. The certificate shall specify the City of Spokane as "Additional Insured" specifically for Consultant's services under this Agreement, as well as all of the parties who are additional insureds, and include applicable policy endorsements, the thirty (30) day cancellation clause, and the deduction or retention level. The Consultant shall be financially responsible for all pertinent deductibles, self-insured retentions, and/or self-insurance.

12. CONTRACTOR'S WARRANTY. The Contractor's warranty for all work, labor and materials shall be in accordance with the contract documents.

13. SUBCONTRACTOR RESPONSIBILITY.

A. The Contractor shall include the language of this section in each of its first tier subcontracts, and shall require each of its subcontractors to include the same language of this section in each of their subcontracts, adjusting only as necessary the terms used for the contracting parties. Upon request of the City, the Contractor shall promptly provide documentation to the City demonstrating that the subcontractor meets the subcontractor responsibility criteria below. The requirements of this section apply to all subcontractors regardless of tier.

B. At the time of subcontract execution, the Contractor shall verify that each of its first tier subcontractors meets the following bidder responsibility criteria:

1. Have a current certificate of registration in compliance with chapter 18.27 RCW, which must have been in effect at the time of subcontract bid submittal;
2. Have a current Washington Unified Business Identifier (UBI) number;
3. If applicable, have:
  - a. Have Industrial Insurance (workers' compensation) coverage for the subcontractor's employees working in Washington, as required in Title 51 RCW;
  - b. A Washington Employment Security Department number, as required in Title 50 RCW;
  - c. A Washington Department of Revenue state excise tax registration number, as required in Title 82 RCW;
  - d. An electrical contractor license, if required by Chapter 19.28 RCW;
  - e. An elevator contractor license, if required by Chapter 70.87 RCW.

4. Not be disqualified from bidding on any public works contract under RCW 39.06.010 or 39.12.065 (3).

C. All Contractors and subcontractors are required to comply with the Spokane Municipal Code (SMC). In accordance with Article X, 7.06 SMC, Public Works Apprentice Program, for public works construction projects as defined in RCW 39.04.010 with an estimated cost of six hundred thousand dollars (\$600,000.00) or more, at least fifteen (15%) percent of the total contract labor project (all contractor and subcontractor hours) shall be performed by apprentices enrolled in a state-approved apprenticeship program.

1. The utilization percentage requirement of apprenticeship labor for public works construction contracts shall also apply to all subcontracts which value exceeds one hundred thousand dollars (\$100,000), provided there is a state-approved apprenticeship program for the trade for which a subcontract is issued (see, SMC 7.06.510).
2. Each subcontractor which this chapter applies is required to execute a form, provided by the city, acknowledging that the requirements of Article X 07.06 SMC are applicable to the labor hours for the project.
3. Each subcontractor is required to submit by the 15th of each month, a City of Spokane Statement of Apprentice/Journeyman Participation form for worked performed the previous month.

14. NONDISCRIMINATION. No individual shall be excluded from participation in, denied the benefit of, subjected to discrimination under, or denied employment in the administration of or in connection with this Contract because of age, sex, race, color, religion, creed, marital status, familial status, sexual orientation including gender expression or gender identity, national origin, honorably discharged veteran or military status, the presence of any sensory, mental or physical disability, or use of a service animal by a person with disabilities. The Contractor agrees to comply with, and to require that all subcontractors comply with, Section 504 of the Rehabilitation Act of 1973 and the Americans with Disabilities Act, as applicable to the Contractor.

15. EXECUTIVE ORDER 11246.

- A. The Contractor will not discriminate against any employee or applicant for employment because of race, color, religion, sex or national origin. The Contractor will take affirmative action to insure that applicants are employed, and that employees are treated during employment, without regard to their race, color, religion, sex or national origin. Such action shall include but not be limited to the following: employment upgrading, demotion or transfer; recruitment or recruitment advertising; layoff or termination; rates of pay or other forms of compensation; and selection for training, including apprenticeship. The Contractor agrees to post in conspicuous places, available to employees and applicants for employment, notices to be provided by the contracting officer setting forth the provisions of this nondiscrimination clause.
- B. The Contractor will, in all solicitations or advertisements for employees placed by or on behalf of the Contractor, state that all qualified applicants will receive consideration for employment without regard to race, color, religion, sex or national origin.

- C. The Contractor will send each labor union, or representative of workers with which it has a collective bargaining contract or other contract or understanding, a notice, to be provided by the agency contracting officer, advising the labor union or workers' representative of the Contractor's commitments under Section 202 of Executive Order No. 11246 of September 24, 1965, and shall post copies of the notice in conspicuous places available to employees and applicants for employment.
- D. The Contractor will comply with all provisions of Executive Order No. 11246 of September 24, 1965, and of the rules, regulations, and relevant orders of the Secretary of Labor.
- E. The Contractor will furnish all information and reports required by Executive Order No. 11246 of September 24, 1965, and by the rules, regulations and orders of the Secretary of Labor, or pursuant thereto, and will permit access to its books, records, and accounts by the contracting agency and the Secretary of Labor for purposes of investigation to ascertain compliance with such rules, regulations and orders.
- F. In the event of the Contractor's noncompliance with the nondiscrimination clauses of this Contract or with any of such rules, regulations or orders, this Contract may be canceled, terminated or suspended in whole or in part, and the Contractor may be declared ineligible for further government contracts in accordance with procedures authorized in Executive Order No. 11246 of September 24, 1965, and such other sanctions may be imposed and remedies invoked as provided in Executive Order No. 11246 of September 24, 1965, or by rule, regulation, or order of the Secretary of Labor, or as otherwise provided by law.
- G. The Contractor will include the provisions of paragraphs A through G in every subcontract or purchase order unless exempted by rules, regulations or orders of the Secretary of Labor issued pursuant to Section 204 of Executive Order No. 11246 of September 24, 1965, so that such provisions will be binding upon each subcontractor or vendor. The Contractor will take such action with respect to any subcontract or purchase order as may be directed by the Secretary of Labor as a means of enforcing such provisions including sanctions for noncompliance: PROVIDED, HOWEVER, that in the event the Contractor becomes involved in, or is threatened with, litigation with a subcontractor or vendor as the result of such direction, the Contractor may request the United States to enter into such litigation to protect the interests of the United States.

16. DEBARMENT AND SUSPENSION. The Contractor has provided its certification that it is in compliance with and shall not contract with individuals or organizations which are debarred, suspended, or otherwise excluded from or ineligible from participation in Federal Assistance Programs under Executive Order 12549 and "Debarment and Suspension", codified at 29 CFR part 98.

17. ASSIGNMENTS. The Contractor may not assign, transfer or sublet any part of the work under this Contract, or assign any monies due, without the written approval of the City, except as may be required by law. In the event of assignment of accounts or monies due under this Contract, the Contractor specifically agrees to give immediate written notice to the City Administrator, no later than five (5) business days after the assignment.

18. ANTI-KICKBACK. No officer or employee of the City of Spokane, having the power or duty to perform an official act or action related to this Contract shall have or acquire any interest in the Contract, or have solicited, accepted or granted a present or future gift, favor, service or other thing of value from or to any person involved in the Contract. Contractor will comply with the Copeland "Anti-Kickback" Act (40 USC 3145), as supplemented by Department of Labor

Regulations (29 CFR Part 3, "Contractors and Subcontractors on Public Building or Public Work Financed in Whole or in Part by Loans or Grants from the United States").

19. COMPLIANCE WITH LAWS. Each party shall comply with all applicable federal, state, and local laws and regulations that are incorporated herein by reference.

20. DISPUTES. This Contract shall be performed under the laws of the State of Washington. Any litigation to enforce this Contract or any of its provisions shall be brought in Spokane County, Washington.

21. SEVERABILITY. In the event any provision of this Contract should become invalid, the rest of the Contract shall remain in full force and effect.

22. AUDIT / RECORDS. The Contractor and its subcontractors shall maintain for a minimum of three (3) years following final payment all records related to its performance of the Contract. The Contractor and its subcontractors shall provide access to authorized City representatives, at reasonable times and in a reasonable manner to inspect and copy any such record. In the event of conflict between this provision and related auditing provisions required under federal law applicable to the Contract, the federal law shall prevail.

23. BUSINESS REGISTRATION REQUIREMENT. Section 8.01.070 of the Spokane Municipal Code states that no person may engage in business with the City without first having obtained a valid annual business registration. The Contractor shall be responsible for contacting the State of Washington Business License Services at [www.dor.wa.gov](http://www.dor.wa.gov) or 360-705-6741 to obtain a business registration. If the Contractor does not believe it is required to obtain a business registration, it may contact the City's Taxes and Licenses Division at (509) 625-6070 to request an exemption status determination.

24. CONSTRUAL. The Contractor acknowledges receipt of a copy of the contract documents and agrees to comply with them. The silence or omission in the contract documents concerning any detail required for the proper execution and completion of the work means that only the best general practice is to prevail and that only material and workmanship of the best quality are to be used. This Contract shall be construed neither in favor of nor against either party.

25. MODIFICATIONS. The City may modify this Contract and order changes in the work whenever necessary or advisable. The Contractor will accept modifications when ordered in writing by the Director of Engineering Services, and the Contract time and compensation will be adjusted accordingly.

26. INTEGRATION. This Contract, including any and all exhibits and schedules referred to herein or therein set forth the entire Agreement and understanding between the parties pertaining to the subject matter and merges all prior agreements, negotiations and discussions between them on the same subject matter.

27. FORCE MAJEURE. Neither party shall be liable to the other for any failure or delay in performing its obligations hereunder, or for any loss or damage resulting therefrom, due to: (1) acts of God or public enemy, acts of government, riots, terrorism, fires, floods, strikes, lock outs, epidemics, act or failure to act by the other party, or unusually severe weather affecting City,

Contractor or its subcontractors, or (2) causes beyond their reasonable control and which are not foreseeable (each a "Force Majeure Event"). In the event of any such Force Majeure Event, the date of delivery or performance shall be extended for a period equal to the time lost by reason of the delay.

**BOZCO CONSTRUCTION, LLC**

**CITY OF SPOKANE**

By \_\_\_\_\_  
Signature                      Date

By \_\_\_\_\_  
Signature                      Date

\_\_\_\_\_  
Type or Print Name

\_\_\_\_\_  
Type or Print Name

\_\_\_\_\_  
Title

\_\_\_\_\_  
Title

Attest:

Approved as to form:

\_\_\_\_\_  
City Clerk

\_\_\_\_\_  
Assistant City Attorney

**Attachments that are part of this Contract:**

- Payment / Performance Bond
  - Exhibit A - Certification Regarding Debarment
  - Exhibit B - Contractor's Response to IPWQ 6225-24
  - Attachment - ARP/CSLFRF CFDA 21.027
  - Attachment – General Terms and Conditions
- 24-186



**PAYMENT / PERFORMANCE BOND**

We, BOZCO CONSTRUCTION, LLC, as principal, and \_\_\_\_\_, as Surety, are held and firmly bound to the City of Spokane, Washington, in the sum of **SIXTY-FOUR THOUSAND NINE HUNDRED AND NO/100 DOLLARS (\$64,900.00)**, for the payment of which, we bind ourselves and our legal representatives and successors, jointly and severally by this document.

The principal has entered into a contract with the City of Spokane, Washington, to do all work and furnish all materials for the West Central Community Center Demolition and Replacement of Courtyard Water Feature. If the principal shall:

- A. promptly and faithfully perform the Contract and any contractual guaranty, and indemnify and hold harmless the City from all loss, damage, or claim which may result from any act or omission of the principal, its agents, employees, or subcontractors; and
- B. comply with all federal, state and local laws and regulations; and
- C. pay all laborers, mechanics, subcontractors, material suppliers and all person(s) who shall supply such person or subcontractors, and pay all taxes and contributions, increases and penalties as authorized by law;

then this obligation shall be null and void; otherwise, it shall remain in full force and effect.

The Surety for value received agrees that no change, extension of time, alteration or addition to the terms of the Contract, the specifications accompanying the Contract, or to the work to be performed under the Contract shall in any way affect its obligation on this bond, except as provided herein, and waives notice of any change, extension of time, alteration or addition to the terms of the Contract or the work performed. The Surety agrees that modifications and changes to the terms and conditions of the Contract that increase the total amount to be paid the Principal shall automatically increase the obligation of the Surety on this bond and notice to Surety is not required for such increased obligation. Any judgment obtained against the City, which relates to or is covered by the contract or this bond, shall be conclusive against the principal and the Surety, as to the amount of damages, and liability, if reasonable notice of the suit has been given.

SIGNED AND SEALED on \_\_\_\_\_.

BOZCO CONSTRUCTION, LLC,  
AS PRINCIPAL

By: \_\_\_\_\_  
Title: \_\_\_\_\_

A valid POWER OF ATTORNEY  
for the Surety's agent must  
accompany this bond.

\_\_\_\_\_  
AS SURETY

By: \_\_\_\_\_  
Its Attorney in Fact

STATE OF WASHINGTON            )  
  ) ss.  
County of \_\_\_\_\_ )

I certify that I know or have satisfactory evidence that \_\_\_\_\_  
\_\_\_\_\_ signed this document; on oath stated that he/she was authorized to  
sign the document and acknowledged it as the agent or representative of the named surety company  
which is authorized to do business in the State of Washington, for the uses and purposes therein  
mentioned.

DATED: \_\_\_\_\_

\_\_\_\_\_  
Signature of Notary Public

My appointment expires \_\_\_\_\_

Approved as to form:

\_\_\_\_\_  
Assistant City Attorney

ATTACHMENT A - CERTIFICATION REGARDING DEBARMENT, SUSPENSION, INELIGIBILITY AND VOLUNTARY EXCLUSION  
AND FEDERAL FUNDING ACCOUNTABILITY AND TRANSPARENCY ACT (FFATA) CERTIFICATION

**Certification Regarding Debarment, Suspension, Ineligibility and Voluntary Exclusion**

This certification is required by the regulations implementing Executive Order 12549, Debarment and Suspension, 2 CFR Part 180.

(1) The prospective primary participant certifies to the best of its knowledge and belief that it and its principals:

- (a) Are not presently debarred, suspended, proposed for disbarment, declared ineligible, or voluntarily excluded from covered transactions by any Federal department or agency;
- (b) Have not within a three-year period preceding this application been convicted of or had a civil judgement rendered against them for commission of fraud or a criminal offense in connection with obtaining, attempting to obtain, or performing a public (Federal, State, or local) transaction or contract under a public transaction; violation of Federal or State antitrust statutes or commission of embezzlement, theft, forgery, bribery, falsification or destruction of records, making false statements, tax evasion, receiving stolen property, making false claims, or obstruction of justice;
- (c) Are not presently indicted for or otherwise criminally or civilly charged by a governmental entity (Federal, State, or local) with commission of any of the offenses enumerated in paragraph (1)(b) of this certification; and
- (d) Have not within a three-year period preceding this Agreement had one or more public transactions (Federal, State, or local) terminated for cause or default.

(2) The undersigned agrees by signing this Agreement that it shall not knowingly enter into any lower tier covered transaction with a person who is debarred, suspended, declared ineligible, or voluntarily excluded from participation in this covered transaction.

(3) The undersigned further agrees by signing this Agreement that it will include the following required certification, without modification, in all lower tier covered transactions and in all solicitations for lower tier covered transactions:

Certification Regarding Debarment, Suspension, Ineligibility, and Voluntary Exclusion - Lower Tier Covered Transactions

1. The lower tier contractor certified, by signing this contract that neither it nor its principals is presently debarred, suspended, proposed for debarment, declared ineligible, or voluntarily excluded from participation in this transaction by any Federal department or agency.

(4) The undersigned shall notify the City immediately that if it or a lower tier contractor become debarred, suspended, proposed for debarment, declared ineligible, or voluntarily excluded from covered transactions by any Federal department or agency during the period of performance of this Agreement.

(5) The terms covered transaction, debarred, suspended, ineligible, lower tier covered transaction, person, primary covered transaction, principal, and voluntarily excluded, as used in this exhibit, have the meanings set out in the Definitions and Coverage sections of the rules implementing Executive Order 12549. The undersigned may contact the City for assistance in obtaining a copy of these regulations.

(6) I understand that a false statement of this certification may be grounds for termination of the Agreement.

**By signing this Attachment, the Grantee indicates acceptance of and compliance with all requirements described above.**

ATTACHMENT A - CERTIFICATION REGARDING DEBARMENT, SUSPENSION, INELIGIBILITY AND VOLUNTARY EXCLUSION  
AND FEDERAL FUNDING ACCOUNTABILITY AND TRANSPARENCY ACT (FFATA) CERTIFICATION

**Federal Funding Accountability and Transparency Act (FFATA) Certification**

**The Federal Funding Accountability and Transparency Act (FFATA) seeks to provide the public with greater access to Federal spending information. Due to FFATA requirements, you are required to provide the following information which will be used by the City to comply with federal reporting requirements.**

If certain conditions are met, Grantee must provide names and total compensation of the top five highly compensated Executives. Please answer question 1, and follow the instructions. If directed to question 2, please answer and follow instructions.

1. In Grantee's previous fiscal year, did Grantee receive (a) 80% or more of Grantee's annual gross revenues in U.S. Federal contracts and subcontracts and other Federal financial assistance subject to the Transparency Act, as defined in 2 CFR 170.320; AND (b) \$25,000,000 or more in annual gross revenues from contracts and subcontracts and other Federal financial assistance subject to the Transparency Act, as defined in 2 CFR 170.320?

Yes  If yes, answer question 2 below.

No  If no, stop, you are not required to report names and compensation. Please sign and submit form with the Agreement.

2. Does the public have access to information about the compensation of Grantee's Executives through periodic reports filed under section 13(a) or 15(d) of the Security Exchange Act of 1934 (15 U.S.C. 78(m)(a), 78o(d)), or section 6104 of the Internal Revenue Code of 1986?

Yes  If yes, stop, you are not required to report names and compensation. Please sign and submit form with the Agreement.

No  If no, you are required to report names and compensation. Please fill out the remainder of this form.

Please provide the names and Total Compensation of the top five most highly compensated Executives in the space below.

Name:	Total Compensation:
Name:	Total Compensation:
Name:	Total Compensation:
Name:	Total Compensation:
Name:	Total Compensation:

**The Grantee certifies that the information contained on this form is true and accurate.**

**By:**

**Title:**

**Date:**



< Business Lookup

**License Information:**

[New search](#) [Back to results](#)

**Entity name:** BOZCO CONSTRUCTION, LLC

**Business name:** BOZCO CONSTRUCTION, LLC

**Entity type:** [Limited Liability Company](#)

**UBI #:** 603-050-025

**Business ID:** 001

**Location ID:** 0001

**Location:** Active

**Location address:** 12123 N FREYA ST  
MEAD WA 99021-5103

**Mailing address:** PO BOX 662  
MEAD WA 99021-0662

**Excise tax and reseller permit status:** [Click here](#)

**Secretary of State status:** [Click here](#)

**Endorsements**

Endorsements held at this location	License #	Count	Details	Status	Expiration date	First issuance date
<a href="#">Edmonds General Business - Non-Resident</a>				Active	Mar-31-2025	Mar-19-2024
<a href="#">Spokane General Business - Non-Resident</a>				Active	Sep-30-2025	Aug-07-2020

**Governing People** May include governing people not registered with Secretary of State

Governing people	Title
BOZIN, PETE	

**Registered Trade Names**

Registered trade names	Status	First issued
BOZCO CONSTRUCTION	Active	Sep-24-2010
BOZCO CONSTRUCTION, LLC	Active	Aug-07-2020



[View Additional Locations](#)

The Business Lookup information is updated nightly. Search date and time: 9/20/2024 8:22:52 AM

**Contact us**

How are we doing?

**Take our survey!**

Don't see what you expected?

**Check if your browser is supported**





# CERTIFICATE OF LIABILITY INSURANCE

DATE (MM/DD/YYYY)

9/23/2024

THIS CERTIFICATE IS ISSUED AS A MATTER OF INFORMATION ONLY AND CONFERS NO RIGHTS UPON THE CERTIFICATE HOLDER. THIS CERTIFICATE DOES NOT AFFIRMATIVELY OR NEGATIVELY AMEND, EXTEND OR ALTER THE COVERAGE AFFORDED BY THE POLICIES BELOW. THIS CERTIFICATE OF INSURANCE DOES NOT CONSTITUTE A CONTRACT BETWEEN THE ISSUING INSURER(S), AUTHORIZED REPRESENTATIVE OR PRODUCER, AND THE CERTIFICATE HOLDER.

**IMPORTANT:** If the certificate holder is an ADDITIONAL INSURED, the policy(ies) must be endorsed. If SUBROGATION IS WAIVED, subject to the terms and conditions of the policy, certain policies may require an endorsement. A statement on this certificate does not confer rights to the certificate holder in lieu of such endorsement(s).

<b>PRODUCER</b> DAMIEN J RAMIREZ (17720) 1137 W GARLAND AVE SPOKANE, WA 99205-0000	<b>CONTACT NAME:</b> DAMIEN J RAMIREZ <b>PHONE (A/C, No, Ext):</b> 509-325-3986 <b>E-MAIL ADDRESS:</b> DAMIEN.RAMIREZ@COUNTRYFINANCIAL.COM	<b>FAX (A/C, No):</b> 509-325-3362
	<b>INSURER(S) AFFORDING COVERAGE</b> <b>INSURER A:</b> COUNTRY Mutual Insurance Company <b>INSURER B:</b> <b>INSURER C:</b> <b>INSURER D:</b> <b>INSURER E:</b> <b>INSURER F:</b>	
<b>INSURED</b> 4853129 BOZCO CONSTRUCTION LLC PO BOX 662 MEAD, WA 99021		

**COVERAGES****CERTIFICATE NUMBER:****REVISION NUMBER:**

THIS IS TO CERTIFY THAT THE POLICIES OF INSURANCE LISTED BELOW HAVE BEEN ISSUED TO THE INSURED NAMED ABOVE FOR THE POLICY PERIOD INDICATED. NOTWITHSTANDING ANY REQUIREMENT, TERM OR CONDITION OF ANY CONTRACT OR OTHER DOCUMENT WITH RESPECT TO WHICH THIS CERTIFICATE MAY BE ISSUED OR MAY PERTAIN, THE INSURANCE AFFORDED BY THE POLICIES DESCRIBED HEREIN IS SUBJECT TO ALL THE TERMS, EXCLUSIONS AND CONDITIONS OF SUCH POLICIES. LIMITS SHOWN MAY HAVE BEEN REDUCED BY PAID CLAIMS.

INSR LTR	TYPE OF INSURANCE	ADDL INSR	SUBR WVD	POLICY NUMBER	POLICY EFF (MM/DD/YYYY)	POLICY EXP (MM/DD/YYYY)	LIMITS	
A	<b>GENERAL LIABILITY</b> <input type="checkbox"/> COMMERCIAL GENERAL LIABILITY <input type="checkbox"/> CLAIMS-MADE <input type="checkbox"/> OCCUR <input type="checkbox"/> BUSINESSOWNERS GEN'L AGGREGATE LIMIT APPLIES PER: <input type="checkbox"/> POLICY <input type="checkbox"/> PRO-JECT <input type="checkbox"/> LOC			AM9393568	6/6/2024	6/6/2025	EACH OCCURRENCE DAMAGE TO RENTED PREMISES (Ea occurrence) MED EXP (Any one person) PERSONAL & ADV INJURY GENERAL AGGREGATE PRODUCTS - COMP/OP AGG	\$ 1,000,000 \$ 50,000 \$ 5,000 \$ 1,000,000 \$ 2,000,000 \$ 2,000,000 \$
A	<b>AUTOMOBILE LIABILITY</b> <input type="checkbox"/> ANY AUTO <input type="checkbox"/> ALL OWNED AUTOS <input type="checkbox"/> HIRED AUTOS <input type="checkbox"/> SCHEDULED AUTOS <input type="checkbox"/> NON-OWNED AUTOS			AV9393578	6/6/2024	6/6/2025	COMBINED SINGLE LIMIT (Ea accident) BODILY INJURY (Per person) BODILY INJURY (Per accident) PROPERTY DAMAGE (Per accident)	\$ 1,000,000 \$ \$ \$
	<b>UMBRELLA LIAB</b> <input type="checkbox"/> EXCESS LIAB <input type="checkbox"/> OCCUR <input type="checkbox"/> CLAIMS-MADE DED <input type="checkbox"/> RETENTION \$						EACH OCCURRENCE AGGREGATE	\$ \$ \$
	<b>WORKERS COMPENSATION AND EMPLOYERS' LIABILITY</b> ANY PROPRIETOR/PARTNER/EXECUTIVE OFFICER/MEMBER EXCLUDED? (Mandatory in NH) If yes, describe under DESCRIPTION OF OPERATIONS below						<input type="checkbox"/> WC STATUTORY LIMITS <input type="checkbox"/> OTH-ER E.L. EACH ACCIDENT E.L. DISEASE - EA EMPLOYEE E.L. DISEASE - POLICY LIMIT	Y / N <input type="checkbox"/> N / A \$ \$ \$

DESCRIPTION OF OPERATIONS / LOCATIONS / VEHICLES (Attach ACORD 101, Additional Remarks Schedule, if more space is required)

JOB NAME:  
 WCCC - DEMO & REPLACEMENT OF COURTYARD WATER FEATURE  
 1603 N. BELT ST.  
 SPOKANE, WA 99205  
 (CONTINUED)

**CERTIFICATE HOLDER****CANCELLATION**

CITY OF SPOKANE FACILITIES MAINTENANCE 221 W. 1ST AVE SPOKANE, WA 99202	SHOULD ANY OF THE ABOVE DESCRIBED POLICIES BE CANCELLED BEFORE THE EXPIRATION DATE THEREOF, NOTICE WILL BE DELIVERED IN ACCORDANCE WITH THE POLICY PROVISIONS.  AUTHORIZED REPRESENTATIVE 
--	--

© 1988-2010 ACORD CORPORATION. All rights reserved.

AGENCY CUSTOMER ID: \_\_\_\_\_

LOC #: \_\_\_\_\_



## ADDITIONAL REMARKS SCHEDULE

Page 1 of 1

AGENCY		NAMED INSURED	
POLICY NUMBER AM9393568		BOZCO CONSTRUCTION LLC PO BOX 662 MEAD, WA 99021	
CARRIER COUNTRY Mutual Insurance Company	NAIC CODE 20990	EFFECTIVE DATE: 9/23/2024	

### ADDITIONAL REMARKS

**THIS ADDITIONAL REMARKS FORM IS A SCHEDULE TO ACORD FORM,**  
**FORM NUMBER:** ACORD 25 **FORM TITLE:** CERTIFICATE OF LIABILITY INSURANCE

(JOB NAME CONTINUED)

ADDITIONAL INSURED(S):  
CITY OF SPOKANE FACILITIES MAINTENANCE  
221 W. 1ST AVE  
SPOKANE, WA 99202



## Bid Response Summary

**Bid Number** IPWQ 6225-24  
**Bid Title** West Central Community Center - Demolition and Replacement of Courtyard Water Feature (ARPA)  
**Due Date** Tuesday, September 10, 2024 3:00:00 PM [(UTC-08:00) Pacific Time (US & Canada)]  
**Bid Status** Closed to Bidding  
**Company** Bozco Construction, LLC  
**Submitted By** Pete Bozin - Tuesday, September 10, 2024 2:09:52 PM [(UTC-08:00) Pacific Time (US & Canada)]  
 bozco@q.com

**Comments**

**Question Responses**

Group	Reference Number	Question	Response
PRE-BID MEETING - MANDATORY			
	1. MANDATORY Pre-Bid Meeting	A MANDATORY pre-bid meeting will be held on Thursday August 29, 2024, at 9:00 am at the West Central Community Center, 1603 N Belt Street., Spokane WA 99205. Only those vendors who attend the Mandatory Pre-Bid Conference will be able to bid on this project.	I acknowledge and I understand
SECTION I. QUOTE PREPARATION AND EVALUATION			
	1. QUOTE PREPARATION	Quotes shall be prepared electronically through the City's ProcureWare site.	I acknowledge and agree
	2. SUBMISSION OF QUOTES	Quotes shall be submitted electronically through the City's ProcureWare site by 3:00 pm on Tuesday, September 10, 2024.	I acknowledge and agree
	3. CONTRACTOR'S REPRESENTATIONS	The Contractor by making its Quote represents that it has read and understands the specifications; and has visited the site and familiarized itself with the local conditions under which the Work is to be performed.	I acknowledge and agree
	4. QUALIFICATION	Prior to the award of contract, the Contractor shall be required to submit evidence of sufficient facilities, equipment, experience and financial ability to insure completion of the Work, unless waived by the City.	I acknowledge and agree

5. AWARD OF CONTRACT	Award of contract, when made by the City, will be to the low responsive-responsible contractor. Unsuccessful firms will not automatically be notified of results.	I acknowledge and agree
6. PAYMENT	Payment will be made via direct deposit/ACH after receipt of the Contractor's application except as provided by state law. If the City objects to all or any portion of the invoice, it shall notify the Contractor and reserves the right to only pay that portion of the invoice not in dispute. In that event, the parties shall immediately make every effort to settle the disputed amount.	I acknowledge and agree
7. REJECTION OF QUOTES	The City reserves the right to reject any or all Quotes, to waive minor deviations from the specifications, to waive minor informalities in the Quote process whenever it is in the City's best interest, and to accept or reject all or part of this Request for Quotes, at the prices shown.	I acknowledge and agree
8. REGISTERED CONTRACTOR	The Contractor shall be a Washington State registered or licensed Contractor at time of Quote submittal.	I acknowledge and agree
9. PUBLIC WORK REQUIREMENTS	The scope of work ("Work") for this Project constitutes a public work under state law. Contractors are warned to take into consideration statutory legal requirements, particularly, the payment of State prevailing wages, securing of a payment/performance bond from a Surety, and sales tax implications in making their Bids. As of July 1, 2019, contractors must have fulfilled the Department of Labor and Industries' Public Works and Prevailing Wage Training Requirement before bidding and/or performing work on public works projects under RCW 39.04.350 and RCW 39.06.020.	I acknowledge and agree

<p>10. CERTIFICATION OF COMPLIANCE WITH WAGE PAYMENT STATUTES</p>	<p>Before award of a Public works contract, the bidder under consideration for award of a public works project must submit to the public agency a sworn statement that they have not willfully violated wage payment laws within the past three years in order to be considered a responsible bidder. (See RCW 39.04.350 as modified by SSB 5301, Laws of 2017, ch. 258.). This form is titled "Certification of Compliance with Wage Payment Statutes". This form must be submitted upon request by City.</p>	<p>I acknowledge and agree</p>
<p>11. BUSINESS REGISTRATION REQUIREMENT</p>	<p>Section 8.01.070 of the Spokane Municipal Code states that no person may engage in business with the City without first having obtained a valid business registration. The Vendor shall be responsible for contacting the State of Washington Business License Services at <a href="http://bls.dor.wa.gov">http://bls.dor.wa.gov</a> or 1-800-451-7985 to obtain a business registration. If the Vendor does not believe it is required to obtain a business registration, it may contact the City's Taxes and Licenses Division at (509) 625-6070 to request an exemption status determination.</p>	<p>I acknowledge and agree</p>
<p>MISCELLANEOUS DOCUMENTATION UPLOAD</p>	<p>Upload any additional documentation here. You can only upload one document so if you have more than one page - combine them into one page before uploading.</p>	
<p>ARPA FUNDING</p>		
<p>**</p>	<p>This project is funded by funds received through the United States Department of Treasury under the American Rescue Plan (ARP/Coronavirus State and Local Fiscal Recovery Funds (CSLFRF) – Catalog of Federal Domestic Assistance (CFDA) number 21.027. Submitting a proposal indicates acceptance of all requirements listed within ARP/CSLFRF CFDA 21.027 Funds document.</p>	<p>YES</p>

1. General Terms & Conditions	I have read, understand and agree with the general terms & conditions in the Documents section of this project.	Yes
2. ARP-CLERF Form	Print, sign and upload the ARP_CLERF Form in the Documents section of this project.	img669.pdf
3. ARPA Debarment Certification	I have read the ARPA Debarment Certification in the Documents tab and understand that If awarded this contract I will be required to sign this document.	Yes
SECTION II. GENERAL REQUIREMENTS		
1. SCOPE OF WORK	Contractor shall be responsible for all permits, permit submittals, tools labor, materials, equipment, transport, safety measures, proper handling and disposal / recycling of all debris to complete the removal of existing glazing and installation of new glazing to complete this work.	I acknowledge and agree
1. Scope of Work	Contractor shall be required to secure all required permits necessary to complete this work.	I understand and I agree
1. Scope of Work	Contractor shall provide all permit drawings, permit submittals, labor, materials, equipment, safety equipment, and proper disposal of debris or project waste necessary for completing this work.	I understand and I agree
1. Scope of Work	Contractor shall protect all existing adjacent finishes and surfaces during all phases of this work.	I understand and I agree
1. SCOPE OF WORK	Contractor shall be required to submit a detailed work plan prior to pre-construction walkthrough for review, revision, and approval by City Facilities.	I understand and I agree
1. SCOPE OF WORK	1. Contractor shall complete the demolition and replacement of the entire existing wood fountain structure in the courtyard of the West Central Community Center.	I understand and I agree

1. SCOPE OF WORK	2. Contractor shall replace ground anchors as necessary to ensure the stability of the structure.	I understand and I agree
1. SCOPE OF WORK	3. Contractor shall construct the structure in the same location and match the existing shape and anchor points of the structure.	I understand and I agree
1. SCOPE OF WORK	a. All fasteners shall be stainless steel and recessed	I understand and I agree
1. SCOPE OF WORK	4. Contractor shall replace with like for like stained wood	I understand and I agree
1. SCOPE OF WORK	a. Contractor shall provide an alternative bid number for replacement with composite materials.	I understand and I agree
1. SCOPE OF WORK	5. Contractor shall stain all wood surfaces with a penetrating, water resistant, stain to match	I understand and I agree
a. EQUIPMENT DELIVERY TIMELINE	What is the delivery timeline for the equipment needed for this project?	It should be no delay for that
2. COMPLETION TIME	All Work under the contract shall be started within ten (10) days after receipt of the Notice to Proceed to substantially complete the specified work by March 31, 2025.	I acknowledge and agree
3. LIQUIDATED DAMAGES	If the Work is not completed within the stated completion time, the Contractor agrees to pay to the City liquidated damages in the amount ZERO (\$0.0) dollars for each and every working until the work is satisfactorily completed. Which is a reasonable forecast of the damages likely to occur if Works is unfinished by the completion date.	I acknowledge and agree
4. INTENT OF SPECIFICATIONS	The apparent silence or omission in the specifications as to any detail of the Work to be done or materials to be furnished means that the region's best general practice shall prevail, and that material and workmanship of the best quality shall be used. The specifications shall be interpreted on this basis.	I acknowledge and agree

<p>6. WASHINGTON STATE RETAIL SALES TAX</p>	<p>A. GENERAL CONSTRUCTION. Retail sales tax, when applicable, will be paid as a separate item, and shall not be included in the Bid price. Sales tax shall be added on the amount due the Contractor and the Contractor shall be responsible for making payment to the State. The City reserves the right to claim an exemption authorized by law.</p>	<p>I acknowledge and agree</p>
<p>6. WASHINGTON STATE RETAIL SALES TAX</p>	<p>B. PUBLIC STREET IMPROVEMENTS. If the technical requirements in the specifications indicate that all or a portion of the Work is a "public street improvement" as defined by state law, the Contractor shall include all contractor-paid taxes, including use taxes on materials in its Bid price. The City will NOT pay retail sales tax as a separate item.</p>	<p>I acknowledge and agree</p>
<p>7. PERMITS</p>	<p>Contractor shall be responsible for all permits, signage, equipment, materials and labor, demolition, dust control, reinstallation of all fixtures as needed, and clean up to complete this work in accordance with industry standards governing this type of work.</p>	<p>I acknowledge and agree</p>
<p>8. GUARANTY</p>	<p>The Contractor guarantees all work, labor and materials for one (1) year following final acceptance of the Work. If any unsatisfactory condition or defect develops within that time, the Contractor shall immediately place the Work in a satisfactory condition, and further repair all damage caused by the condition or defect at its sole expense. This guarantee shall not apply all Work, which has been abused or neglected by the City.</p>	<p>I acknowledge and agree</p>
<p>9. SUBCONTRACTORS</p>	<p>The Contractor shall not award any portion of the Work to any subcontractor without the City's prior approval. The Contractor shall be fully responsible to the City for the acts, errors and omissions of its subcontractors. No contractual relationship shall be created between any subcontractor and the City.</p>	<p>I acknowledge and agree</p>

10. INSURANCE	During the term of the Contract, the Contractor shall maintain in force at its own expense, the below insurance coverage(s):	I acknowledge and agree
10. INSURANCE	a. Worker's Compensation Insurance in compliance with RCW 51.12.020 which requires subject employers to provide worker's compensation coverage for all their subject workers and Employer's Liability Insurance in the amount of \$1,000,000.00.	I acknowledge and agree
10. INSURANCE	b. General Liability Insurance on an occurrence basis, with a combined single limit of not less than \$1,000,000.00 for bodily injury and property damage. It shall include premises and operations, independent contractors, products and completed operations, personal injury liability, and contractual liability coverage for the indemnity provided under the contract. It shall provide that the City, its officers and employees are additional insureds but only with respect to the Contractor's services to be provided under the contract; i. Acceptable supplementary Umbrella insurance coverage, combined with the Contractor's General Liability Insurance policy must be a minimum of \$1,500,000.00 in order to meet the insurance coverages required under this Contract;	I acknowledge and agree
10. INSURANCE	c. Property Insurance if materials and supplies are furnished by the Contractor. The amount of the insurance coverage shall be the value of the materials and supplies or the completed value of the improvement. Hazard or XCU (Explosion, Collapse, Underground) Insurance should be provided if any hazard exists; and	I acknowledge and agree
10. INSURANCE	d. Automobile Liability Insurance with a combined single limit, or the equivalent of not less than \$1,000,000.0 each accident for bodily injury and property damage, including coverage for owned, hired and non-owned vehicles.	I acknowledge and agree

<p>10. INSURANCE</p>	<p>There shall be no cancellation, material change, reduction of limits or intent not to renew the insurance coverage(s) without thirty (30) days written notice from the Company or its insurer(s) to the City. As evidence of the insurance coverage(s) required by this Agreement, the Company shall furnish acceptable Certificates of Insurance (COI) upon request by the City. The certificate shall specify the City of Spokane as "Additional Insured" specifically for Company's services under this Agreement, as well as all of the parties who are additional insureds, and include applicable policy endorsements, the thirty (30) day cancellation clause, and the deduction or retention level. The Company shall be financially responsible for all pertinent deductibles, self-insured retentions, and/or self-insurance.</p>	<p>I acknowledge and agree</p>
<p>11. PERFORMANCE BONDS</p>	<p>The Contractor shall furnish, at its sole expense, a performance and payment bond equal to one hundred percent (100%) of the contract price. The bond shall insure faithful and complete performance of the contract and payment of all obligations to laborers and material men arising from the Project. The bond shall be executed by a Surety company authorized to do business in Washington State, and shall remain in effect for one (1) year following final acceptance of the work. Unless approved by the City, the Surety's name shall appear on the United States Treasury Department's list of authorized Sureties - Circular 570. On contracts of \$150,000.00 or less, in lieu of a surety bond, at the request of the Contractor, the City may retain ten percent (10%) of the contract price for a minimum of forty five (45) days following final acceptance, or until receipt of all releases and settlement of liens, whichever is later, in accord with RCW 39.08010.</p>	<p>I acknowledge and agree</p>



<p>12. PREVAILING WAGES - LOCAL AND STATE ASSISTED CONSTRUCTION.</p>	<p>A. The State prevailing rate of wages to be paid to all workmen, laborers or mechanics employed in the performance of any part of this Contract shall be in accordance with the provisions of RCW 39.12 and the rules and regulations of the Washington State Department of Labor and Industries (L&amp;I).</p>	<p>I acknowledge and I agree</p>
<p>12. PREVAILING WAGES - LOCAL AND STATE ASSISTED CONSTRUCTION.</p>	<p>B. The State of Washington prevailing wage rates applicable for this public works project, which is located in Spokane County, may be found at the following website address of the Department of Labor and Industries: <a href="https://lni.wa.gov/licensing-permits/public-works-projects/prevaling-wage-rates/">https://lni.wa.gov/licensing-permits/public-works-projects/prevaling-wage-rates/</a> Based on the Quote submittal deadline for this Project, the applicable effective date for State prevailing wages for this Project is September 10, 2024.</p>	<p>I acknowledge and I agree</p>
<p>12. PREVAILING WAGES - LOCAL AND STATE ASSISTED CONSTRUCTION.</p>	<p>C. If apprentices are to be used, they must be registered with the State Apprenticeship Council; otherwise, they are to be paid State prevailing journeyman wages.</p>	<p>I acknowledge and I agree</p>
<p>13. RETAINAGE</p>	<p>Pursuant to chapter 60.28 RCW, the City will retain five percent (5%) (or ten percent (10%) at Contractor's request) from the monies earned by the Contractor. This Retainage shall be held as a trust fund for the protection and payment: (1) to the State of taxes and fees owed by the Contractor; and (2) of any person, mechanic, subcontractor or material man who performs labor or furnishes any supplies toward the Work. Release of Retainage will be made at a minimum of forty five (45) days following final acceptance of Work; provided the following conditions are met:</p>	<p>I acknowledge and I agree</p>

13. RETAINAGE

a. The City has received from the Contractor and each subcontractor a copy of the "Statement of Intent to Pay Prevailing Wages" and an "Affidavit of Wages Paid", approved by the State Department of Labor and Industries (L&I). b. On Contracts greater than \$35,000, the City has received releases from the State Departments of Revenue (DOR), Labor & Industries and Employment Security. c. No claims, as provided by law, have been filed against the retainage In the event a claim is filed, the Contractor shall be paid a portion of the Retainage, which is less than the amount sufficient to pay the claim and potential legal costs.

I acknowledge and  
I agree

14. Proprietary Information	<p>Materials submitted in response to this competitive procurement shall become the property of the City. All received Proposals shall remain confidential until the award of contract recommendation has been filed with the applicable Council Committee or the City Clerk for City Council action. Thereafter, the Proposals shall be deemed public records as defined in RCW 42.56, "Public Records." Any information in the Proposal that the Proposer desires to claim as proprietary and thus exempt from disclosure under the provisions of existing state law, shall be clearly designated. Each page claimed to be exempt from disclosure must be clearly identified by the word "Confidential" printed on it. Marking the entire Proposal exempt from disclosure will not be honored. The City will consider a Proposer's request for exemption from disclosure; however, the City will make a decision predicated upon state law and regulations. If any information is marked as proprietary in the Proposal, it will not be made available until the affected Proposer has been given an opportunity to seek a court injunction against the requested disclosure.</p>	I understand and I agree
SECTION III. TECHNICAL REQUIREMENTS		
Section A - General	<p>Scope of Work is located in the Section II - General Requirements above - Acknowledging here means you have read and agree with said information. If you do not agree with said information, please list the items you do not agree with in the next field.</p>	I understand and I agree
2	<p>If you do not agree with anything listed in the information listed above - please list that information here.</p>	
BID		

BIDDER'S DECLARATION	The Bidder submitting this bid certifies that it has examined the site, read and understands the specifications for the above project, and agrees to comply with all applicable federal, state and local laws and regulations. The bidder is advised that by submitting this bid proposal it has acknowledged all bid requirements and certifications contained herein.	I acknowledge and I agree
BID PRICE IS COMPLETE	Bidder acknowledges that the bid price indicated on the Pricing Page includes ALL expenses with regard to this project. No other costs will be allowed over and above the bid price.	I acknowledge and I agree
CONTRACTOR RESPONSIBILITY	Washington State Contractor's Registration Number	BOZCOCL905PL
CONTRACTOR RESPONSIBILITY	U.B.I. Number	603050025
CONTRACTOR RESPONSIBILITY	Washington Employment Security Department Number	38847800-7
CONTRACTOR RESPONSIBILITY	Washington Excise Tax Registration Number	603-050-025
CONTRACTOR RESPONSIBILITY	City of Spokane Business Registration Number	BOZCOCL905PL
CONTRACTOR RESPONSIBILITY	As of July 1, 2019, Contractor has fulfilled training requirements or is exempt from L&I's Public Works Training Requirement under RCW 39.04.350 and RCW 39.06.020	Yes
ADDENDA	Bidder acknowledges receipt of _____ addenda and agrees that their requirements have been included in this bid proposal.	1
MISCELLANEOUS	The firm agrees that its Bid will NOT be withdrawn for a minimum of forty-five (45) calendar days after the stated submittal date.	I acknowledge and I agree
MISCELLANEOUS	For contracts up to \$150,000.00 including tax, the Contractor may request a 10 percent (10%) retainage in lieu of bond.	Yes
MISCELLANEOUS	If this project is less than \$150,000 - does contractor request 10% retainage in lieu of bond?	Yes

MISCELLANEOUS	The bidder submitting this response hereby certifies that, within the three-year period immediately preceding the bid solicitation date for this Project, the bidder is not a "willful" violator, as defined in RCW 49.48.082, of any provision of chapters 49.46, 49.48 or 49.52 RCW, as determined by a final and binding citation and notice of assessment issued by the Department of Labor and Industries or through a civil judgement entered by a court of limited or general jurisdiction. I certify (or declare) under penalty of perjury under the laws of the State of Washington that the foregoing is true and correct.	I acknowledge and I agree
MISCELLANEOUS	Individual's Name, Company Name, Address, Email Address & Phone Number for individual/company submitting this bid response.	Pete Bozin Bozco Construction, llc Po Box 662. Mead, WA 99021 (509) 499-1387
MISCELLANEOUS	Individuals name and email address who is authorized to sign contract	Pete Bozin BOZCO@Q.COM
BID BOND	Fill out the Bid Bond, located in the Documents Tab in ProcureWare and upload it here	img666.pdf
SUBCONTRACTORS	Fill out the Subcontractor List, located in the Documents Tab in ProcureWare and upload it here	img668.pdf
TERMS & CONDITIONS		
#1	Bidder accepts has read and acknowledges compliance with Terms and Conditions located in the Documents area of this project. If answer is "I do not acknowledge and I do not agree", include requested exception in proposal submittal on separate page and title as "Exception to Terms and Conditions". The City will consider and determine if exception will be accepted.	I acknowledge and I agree

#2	Describe exceptions to Terms & Conditions if you marked "I do not acknowledge and I do not agree" above.	None
----	--	------

**Pricing Responses**

Group	Reference Number	Description	Type	Unit Of Measure	Quantity	Unit Price	Ext Base Price	Comment
BID								
	1.	West Central Community Center - Demolition and Replacement of Courtyard Water Feature (ARPA)	Base	JB	1.00	\$64,900.00	\$64,900.00	Sixty Four Thousand Nine Hundred
	2.	9% Sales Tax	Base	ea	1.00	\$5,841.00	\$5,841.00	Five Thousand Eight Hundred Forty One
	Alternate #1	- Rebuilding Courtyard Water Feature with composite material	Option	jb	1.00	\$3,000.00		Three Thousand
<b>Total Base Bid</b>		\$70,741.00						

**ATTACHMENT A– ARP/CSLFRF CFDA 21.027 FUNDING**  
American Rescue Plan (ARP)  
Coronavirus State and Local Fiscal Recovery Funds (CSLFRF)  
Funding Authority: U.S. Department of Treasury  
CFDA# 21.027 – Coronavirus State and Local Fiscal Recovery Funds

The Contractor specifically agrees to comply with all applicable state and federal laws, rules, regulations, requirements, program guidance, including but not limited to the following:

All applicable federal, state, and local laws, regulations, executive orders, OMB Circulars, and/or policies including, but not limited to:

Nondiscrimination laws and/or policies, and safety and health regulations.  
Americans with Disabilities Act (ADA), Age Discrimination Act of 1975,  
Title VI of the Civil Rights Act of 1964, Civil Rights Act of 1968,  
Provisions in Buildings for Aged and Handicapped Persons (RCW 70.92).  
Robert T. Stafford Disaster Relief and Emergency Assistance Act (PL 93-288, as amended),  
Ethics in Public Services (RCW 42.52),  
Covenant Against Contingent Fees (48 CFR Section 52.203-5),  
Public Records Act (RCW 42.56),  
Prevailing Wages on Public Works (RCW 39.12),  
State Environmental Policy Act (RCW 43.21C),  
Shoreline Management Act of 1971 (RCW 90.58),  
State Building Code (RCW 19.27),  
Energy Policy and Conservation Act (PL 94-163, as amended),  
Energy Related Building Standards (RCW 19.27A),

Comply with all procurement requirements of 2 CFR Part 200.317 - 200.327. All sole source contracts expected to exceed \$50,000 must be submitted to Spokane City Purchasing for review and approval prior to the award and execution of a contract.

Any contract awarded to the successful Contractor must contain and/or comply with the following procurement provisions in accordance with 2 CFR Part 200.317 - 200.327:

Contractor must maintain a Conflict of Interest Policy consistent with 2 CFR 200.318(c) that is applicable to all activities funded with the award. All potential conflicts of interest related to this award must be reported to Spokane City and/or U.S. Treasury

- Administrative, contractual, or legal remedies in instances where contractors violate or breach contract terms, and provide for such sanctions and penalties as may be appropriate;
- Compliance with Executive Order 11246, “Equal Employment Opportunity,” (30 FR 12319, 12935, 3 CFR Part 1964-1965 Comp., p. 339), as amended by Executive Order 11375, as supplemented in Department of Labor regulations (41 CFR Chapter 60);
- For Capital Expenditures that involve the employment of mechanics of laborers: Compliance with the Contract Work Hours and Safety Standards Act (40 USC 3702 and 3704) as supplemented by Department of Labor Regulations (29 CFR Part 5);
- For all contracts in excess of \$100,000 with respect to water, sewer, or broadband that involve the employment of mechanics of laborers: Compliance with the Contract Work Hours and Safety Standards Act (40 USC 3702 and 3704) as supplemented by Department of Labor Regulations (29 CFR Part 5);
- For construction or repair contracts: Compliance with the Copeland “Anti-Kickback” Act (40 U.S.C. 3145) as supplemented by Department of Labor regulations (29 CFR part 3);
- For construction contracts in excess of \$2,000 when required by Federal grant program legislation:

Compliance with the Davis-Bacon Act (40 U.S.C. 3141-3144 and 3146-3148) as supplemented by Department of Labor regulations (29 CFR part 5); Davis Bacon Act—Does **not** apply to projects funded **solely** with ARPA/CSLFRF CFDA 21.027 funds. However, if other federal funds are also used for the construction project in addition to FRF, and those federal funds require Davis-Bacon compliance, all prime construction contracts in excess of \$2,000 must follow Davis-Bacon Act;

- For construction contracts in excess of \$100,000 that involve the employment of mechanics and laborers: Compliance with the Contract Work Hours and Safety Standard Act (40 U.S.C. 3701-3708) as supplemented by Department of Labor regulations (29 CFR Part 5);
- Compliance with the requirements of 37 CFR Part 401, “Rights to Inventions Made by Nonprofit Organizations and Small Business Firms Under Government Grants, Contracts and Cooperative Agreements,” and any implementing regulations issued by the awarding agency
- For contracts in excess of \$150,000: Compliance with all applicable standards, orders or requirements issued under the Clean Air Act (42 U.S.C. 7401-7671q.) and the Federal Water Pollution Control Act (33 U.S.C. 1251-1387) as amended;
- Compliance with section 6002 of the Solid Waste Disposal Act, as amended by the Resource Conservation and Recovery Act;
- Notice of awarding agency requirements and regulations pertaining to reporting;
- Federal awarding agency requirements and regulations pertaining to copyrights and rights in data;
- Access by Spokane City, the Federal awarding agency, the Comptroller General of the United States, or any of their duly authorized representatives to any books, documents, papers and records, sub-agreements, leases, subcontracts, arrangements, or other third-party agreements of any type, and supporting materials related to those records of the Contractor, which are directly pertinent to that specific contract for the purpose of making audit, examination, excerpts and transcriptions;
- Retention of all required records for **six years** after Spokane City makes final payment and all other pending matters are closed;
- Mandatory standards and policies relating to energy efficiency which are contained in the state energy conservation plan issued in compliance with the Energy Policy and Conservation Act (Pub. L. 94-163, 89 Stat. 871);
- Notice of awarding agency requirements and regulations governing the development, reporting, and disposition of rights to inventions and patents resulting from financial assistance awards (37 C.F.R. Part 401) and the standard patent rights clause (37 C.F.R. section 401.14);
- Compliance with Executive Order 13858 “Strengthening Buy-American Preferences for Infrastructure Projects” as appropriate and to the extent consistent with law; and
- Compliance with 2 C.F.R. § 200.216, prohibitions regarding certain telecommunications and video surveillance services or equipment are mandated by section 889 of the John S. McCain National Defense Authorization Act for Fiscal Year 2019 (FY 2019 NDAA), Pub. L. No. 115-232 (2018).

Any contract awarded to the successful Contractor must contain and/or comply with the following provisions in accordance with 2 CFR Part 200.332(a) - 200.332(a)(1)-200.332(a)(6) Requirements for pass-through entities:

- Identify as a Subaward (2 CFR 200.332(a));
- Federal Award Identification (2 CFR 200.332(a)(1));
- Terms and conditions from ARP/CLFRF (2 CFR 200.332(a)(2));
- Additional City of Spokane imposed requirements based on risk assessment (2 CFR 200.332(a)(3));
- Indirect cost rate (2 CFR 200.332(a)(4));
- Records access & retention (2 CFR 200.332(a)(5));
- Closeout provisions (2 CFR 200.332(a)(6)).



Any contract awarded to the successful Contractor must contain and/or comply with the following provisions in accordance with 2 CFR Part 200.501(a)-200.501(h) Audit Requirements:

- Audit required. A non-Federal entity that expends \$750,000 or more during the non-Federal entity's fiscal year in Federal awards must have a single or program-specific audit conducted for that year in accordance with the provision of this part (2 CFR 200.501(a));
- Single Audit (2 CFR 200.501(b));
- Program-specific audit election (2 CFR 200.501(c));
- Exemption when Federal awards expended are less than \$750,000(2 CFR 200.501(d));
- Federally Funded Research and Development Centers (2 CFR 200.501(e));
- Subrecipients and contractors (2 CFR 200.501(f));
- Compliance responsibility for contractors (2 CFR 200.501(g));
- For-profit subrecipient (2 CFR 200.501(h)).

Contractor must comply with Executive Orders 12549 and 12689 and 2 C.F.R. Part 180, which restrict awards, subawards, and contracts with certain parties that are debarred, suspended, or otherwise excluded from or ineligible for participation in federal assistance programs or activities. Contractor must certify that it is not presently debarred, suspended or proposed for debarment, declared ineligible, or voluntarily excluded from participating in this Agreement by any federal department or agency.

Contractor must comply with the requirements of 31 U.S.C. § 3729-3733 which prohibits the submission of false or fraudulent claims for payment to the Federal Government. See also 31 U.S.C. § 3801-3812 which details the administrative remedies for false claims and statements made.

Contractor is required to be non-delinquent in their repayment of any Federal debt. Examples of relevant debt include delinquent payroll and other taxes, audit disallowances, and benefit overpayments. See OMB Circular A-129.

Contractor's costs must be compliant with 2 CFR Part 200 Subpart E Cost Principles.

Contractor must comply with 31 U.S.C. § 1352, which provides that none of the funds provided under an award may be expended by the recipient to pay any person to influence, or attempt to influence an officer or employee of any agency, Member of Congress, an officer, or employee of Congress, or an employee of a Member of Congress in connection with any Federal action concerning an award, making of any federal grant, federal loan, continuation, renewal, amendment or modification of any federal contract, grant loan, or cooperative agreement, and that if any funds other than federal appropriated funds have been paid or will be paid to any person for influencing or attempting to influence an officer or employee of any agency, a Member of Congress, an officer or employee of Congress, or an employee of a Member of Congress in connection with this award, the Contractor will complete and submit Standard Form-LLL, "Disclosure Form to Report Lobbying," in accordance with its instructions.

In the event of the Contractor's noncompliance or refusal to comply with any applicable law, regulation, executive order, OMB Circular or policy, Spokane City may rescind, cancel, or terminate the contract in whole or in part in its sole discretion. The Contractor is responsible for all costs or liability arising from its failure to comply with applicable laws, regulations, executive orders, OMB Circulars, or policies.

## CERTIFICATION

\_\_\_\_\_  
Signature, Administrator, or Applicant Agency

\_\_\_\_\_  
Date

\_\_\_\_\_  
print name and title

## **General Terms & Conditions**

### **1. CONTRACTING WITH CURRENT OR FORMER CITY EMPLOYEES**

Specific restrictions apply to contracting with current or former City officers and employees pursuant to the Code of Ethics in chapter 1.04A of the Spokane Municipal Code. Proposers shall familiarize themselves with the requirements prior to submitting a Proposal that includes current or former City officers or employees.

### **2. PROPRIETARY INFORMATION / PUBLIC DISCLOSURE**

All materials submitted to the City in responses to this competitive procurement shall become the property of the City.

All materials received by the City are public records and are subject to being released pursuant to a valid public records request. Washington state law mandates that all documents used, received or produced by a governmental entity are presumptively public records, and there are few exemptions. Chapter 41.56 RCW.

When responding to this competitive procurement, please consider that what you submit will be a public record. If you believe that some part of your response constitutes legally protected proprietary information, you MUST submit those portions of your response as a separate part of your response, and you MUST label it as "PROPRIETARY INFORMATION." If a valid public records request is then received by the City for this information, you will be given notice and a 10-day opportunity to go to court to obtain an injunction to prevent the City from releasing this part of your response. If no injunction is obtained, the City is legally required to release the records.

The City will neither look for nor honor any claims of "proprietary information" that are not within the separate part of your response.

### **3. OWNERSHIP OF DOCUMENTS**

Any and all data, reports, analyses, documents, photographs, pamphlets, plans, specifications, surveys, films or any other material created, prepared, produced, constructed, assembled, made, performed or otherwise produced by the Firm or the Firm's subcontractors or consultants for delivery to the City under this Agreement shall be the sole and absolute property of the City. Such property shall constitute "work made for hire" as defined by U.S. Copyright Act of 1976, 17 U.S.C. § 101, and the ownership of the copyright and any other intellectual property rights in such property shall vest in the City at the time of its creation. Ownership of the intellectual property includes the right to copyright, patent, and register, and the ability to transfer these rights. Material which the Firm uses to perform this Agreement, but is not created, prepared, constructed, assembled, made, performed or otherwise produced for, or paid for, by the City is owned by the Firm and is not "work made for hire" within the terms of this Agreement.

### **4. ACCEPTANCE PERIOD**

Proposals shall remain in effect for ninety (90) days for acceptance by the City from the due date for receipt of Proposals.

### **5. COSTS TO PROPOSE**

The City will not be liable for any costs incurred by the Proposer in preparation of a Proposal submitted in response to this RFP, in conduct of a presentation, or any other activities related to responding to this RFP.

## **6. INTERLOCAL PURCHASE AGREEMENTS**

The City of Spokane has entered into Interlocal Purchase Agreements with other public agencies pursuant to Chapter 39.34 RCW. In submitting a response, the Proposer agrees to provide its services to other public agencies at the same contracted price, terms and conditions it is providing to the City of Spokane, contingent upon the Firm's review and approval at the time of a requested contract. The Firm's right to refuse to enter into a contract with another public agency at the time of request shall be absolute.

## **7. DEBRIEFING OF UNSUCCESSFUL PROPOSERS**

Upon request, a debriefing conference will be scheduled with an unsuccessful Proposer. Discussion will be limited to a critique of the requesting Firm's Proposal. Debriefing conferences may be conducted in person or on the telephone.

## **8. MINORITY & WOMEN-OWNED BUSINESS PARTICIPATION**

The City encourages participation in all of its contracts by Firms certified by the Washington State Office of Minority and Women's Business Enterprises (OMWBE). Proposers may contact OMWBE at (360)753-9693 to obtain information on certified Firms.

## **9. NONDISCRIMINATION**

No individual shall be excluded from participation in, denied the benefit of, subjected to discrimination under, or denied employment in the administration of or in connection with this Contract because of age, sex, race, color, religion, creed, marital status, familial status, sexual orientation including gender expression or gender identity, national origin, honorably discharged veteran or military status, the presence of any sensory, mental or physical disability, or use of a service animal by a person with disabilities. The Firm agrees to comply with, and to require that all subcontractors comply with, Section 504 of the Rehabilitation Act of 1973 and the Americans with Disabilities Act, as applicable to the Firm.

## **10. BUSINESS REGISTRATION REQUIREMENT**

Section 8.01.070 of the Spokane Municipal Code states that no person may engage in business with the City without first having obtained and currently being the holder of a valid annual business registration or temporary business registration as provided in this chapter. The Firm shall be responsible for contacting the State of Washington Business License Services at <http://dor.wa.gov> or 1-360-705-6741 to obtain a business registration. If the Firm does not believe it is required to obtain a business registration, it may contact the City's Taxes and Licenses Division at 509-625-6070 to request an exemption status determination.

## **11. PAYMENT**

Payment will be made via direct deposit/ACH except as provided by state law. A completed ACH application is required before a City Order will be issued. If the City objects to all or any portion of the invoice, it shall notify the Company and reserves the right to only pay that portion of the invoice not in dispute. In that event, the parties shall immediately make every effort to settle the disputed amount.

## **12. ANTI-KICKBACK**

No officer or employee of the City of Spokane, having the power or duty to perform an official act or action related to this contract shall have or acquire any interest in the contract, or have solicited,

accepted or granted a present or future gift, favor, service or other thing of value from or to any person involved in the contract.

### **13. DISPUTES**

This contract shall be performed under the laws of Washington State. Any litigation to enforce this contract or any of its provisions shall be brought in Spokane County, Washington.

### **14. TERMINATION**

- A. For Cause: The City or Consultant may terminate the Agreement if the other party is in material breach of this Agreement, and such breach has not been corrected to the other party's reasonable satisfaction in a timely manner. Notice of termination under this Section shall be given by the party terminating this Agreement to the other, not fewer than thirty (30) business days prior to the effective date of termination.
- B. For Reasons Beyond Control of Parties: Either party may terminate this Agreement without recourse by the other where performance is rendered impossible or impracticable for reasons beyond such party's reasonable control, such as, but not limited to, an act of nature, war or warlike operation, civil commotion, riot, labor dispute including strike, walkout or lockout, except labor disputes involving the Consultant's own employees, sabotage, or superior governmental regulation or control. Notice of termination under this Section shall be given by the party terminating this Agreement to the other, not fewer than thirty (30) business days prior to the effective date of termination.
- C. For Convenience: Either party may terminate this Agreement without cause, upon thirty (30) days written notice to the other party.
- D. Actions upon Termination: if termination occurs not the fault of the Consultant, the Consultant shall be paid for the services properly performed prior to the actual termination date, with any reimbursable expenses then due, but such compensation shall not exceed the maximum compensation to be paid under the Agreement. The Consultant agrees this payment shall fully and adequately compensate the Consultant and all subconsultants for all profits, costs, expenses, losses, liabilities, damages, taxes, and charges of any kind (whether foreseen or unforeseen) attributable to the termination of this Agreement.
- E. Upon termination, the Consultant shall provide the City with the most current design documents, contract documents, writings, and other products the Consultant has produced to termination, along with copies of all project-related correspondence and similar items. The City shall have the same rights to use these materials as if termination had not occurred; provided however, that the City shall indemnify and hold the Consultant harmless from any claims, losses, or damages to the extent caused by modifications made by the City to the Consultant's work product.

### **15. LIABILITY**

The Firm shall indemnify, defend, and hold harmless the City, its officers, and employees from all claims, demands, or suits in law or equity arising from the Firm's negligence or breach or its obligations under the contract. The Firm's duty to indemnify shall not apply to liability caused by the sole negligence of the City, its officers, and employees. The Firm's duty to indemnify for liability arising from the concurrent negligence of the City, its officers and employees and the Firm, its officers and employees shall apply only to the extent of the negligence of the Firm, its officers and employees. The Firm's duty to indemnify shall survive

termination or expiration of the contract. The Firm waives, with respect to the City only, its immunity under RCW Title 51, Industrial Insurance.

## **16. INSURANCE COVERAGE**

During the term of the contract, the Firm shall maintain in force at its own expense, each insurance coverage noted below:

- A. Worker's Compensation Insurance in compliance with RCW 51.12.020, which requires subject employers to provide workers' compensation coverage for all their subject workers and Employer's Liability Insurance in the amount of \$1,000,000.
- B. General Liability Insurance on an occurrence basis, with a combined single limit of not less than \$1,000,000 each occurrence for bodily injury and property damage. It shall include contractual liability coverage for the indemnity provided under this contract. It shall provide that the City, its officers and employees are additional insureds, but only with respect to the Firm's services to be provided under this contract.
- C. Automobile Liability Insurance with a combined single limit, or the equivalent of not less than \$1,000,000 each accident for bodily injury and property damage, including coverage for owned, hired and non-owned vehicles.
- D. Professional Liability Insurance with a combined single limit of not less than \$1,000,000 each claim, incident, or occurrence. This is to cover damages caused by the error, omission, or negligent acts related to the professional services to be provided under this contract. The coverage must remain in effect for at least three (3) years after the contract is completed.

There shall be no cancellation, material change, reduction of limits or intent not to renew the insurance coverage(s) without forty-five (45) days written notice from the Firm or its insurer(s) to the City.

As evidence of the insurance coverages required by this contract, the Firm shall furnish acceptable insurance certificates to the City at the time it returns the signed contract. The certificate shall specify all of the parties who are additional insured, and include applicable policy endorsements, and the deductible or retention level, as well as policy limits. Insuring companies or entities are subject to City acceptance and must have a rating of A- or higher by Best. Copies of all applicable endorsements shall be provided. The Firm shall be financially responsible for all pertinent deductibles, self-insured retentions, and/or self-insurance.

## **SPECIFIC GRANT RELATED LANGUAGE**

### **17. CERTIFICATION REGARDING DEBARMENT, SUSPENSION, INELEGIBILITY AND VOLUNTARY EXCLUSION**

A certification form will accompany the contract to be signed confirming that, to the best of its knowledge and belief, Firm, and its principals:

- A. Are not presently debarred, suspended, proposed for debarment, declared ineligible, or voluntarily excluded from covered transactions by any federal department or agency.
- B. Have not within a three-year period preceding this contract been convicted or had a civil judgment rendered against them for commission of fraud or a criminal offense in connection with obtaining, attempting to obtain, or performing a public (federal, state, or local) transaction or contract under a public transaction; violation of federal or state antitrust statutes or commission of embezzlement, theft, forgery, bribery, falsification or destruction of records, making false statements, tax evasion, receiving stolen property, making false claims, or obstruction of justice.

- C. Are not presently indicted or otherwise criminally or civilly charged by a government entity (federal, state, or local) with commission of any of the offenses enumerated in paragraph (1)(b) of this certification.
- D. Have not within a three-year period preceding this contract had one or more public transactions (federal, state, or local) terminated for cause or default.

**18. CERTIFICATION REGARDING LOBBYING**

Byrd Anti-Lobbying Amendment (31 U.S.C. 1352) – Firms who apply or bid for an award of \$100,000 or more shall file the required certification. Each tier certifies to the tier above that it will not and has not used Federal appropriated funds to pay any person or organization for influencing or attempting to influence an officer or employee of any agency, a member of Congress, officer or employee of Congress, or an employee of a member of Congress in connection with obtaining any Federal contract, grant or any other award covered by 31 U.S.C. 1352. Each tier shall also disclose any lobbying in non-Federal funds that takes place in connection with obtaining any Federal award. Such disclosures are forwarded from tier to tier up to the recipient.

A Certification Form is attached and included in this Request for Proposal by reference as Attachment A “Certification Regarding Lobbying”. The Proposer is required to sign and submit this Form with Proposal. The Proposer certifies by signing and submitting this Proposal, to the best of his or her knowledge and belief, that:

- A. No Federal appropriated funds have been paid or will be paid, by or on behalf of the undersigned, to any person for influencing or attempting to influence an officer or employee of any Federal agency, a Member of Congress, an officer or employee of Congress, or any employee of a Member of Congress in connection with the awarding of any Federal grant, the making of any Federal loan, the entering into of any cooperative agreement, and the extension, continuation, renewal, amendment or modification of any Federal contract, grant, loan, or cooperative agreement.
- B. If any funds other than Federal appropriated funds have been paid or will be paid to any person for influencing or attempting to influence an officer or employee of any Federal agency, a Member of Congress, an officer or employee of Congress, or an employee of a Member of Congress in connection with this Federal contract, grant, loan, or cooperative agreement, the undersigned shall complete and submit Standard Form-LLL, "Disclosure of Lobbying Activities," in accordance with its instructions.
- C. The Proposer also agrees by submitting his or her Proposal, that he or she shall require that the language of this certification be included in all lower tier subcontracts. Which exceed \$100,000 and that all such sub-recipients shall certify and disclose accordingly.
- D. This certification is a material representation of fact upon which reliance was placed when this transaction was made or entered into. Submission of this certification is a prerequisite for making or entering into this transaction imposed by section 1352, title 31, United States Code. Any person who fails to file the required certification shall be subject to a civil penalty of not less than \$10,000 and not more than \$100,000 for each such failure.

**19. DOMESTIC PREFERENCE**

200.322 (a) As appropriate and to the extent consistent with law, the non-Federal entity should to the greatest extent practicable under a Federal award, provide a preference for the purchase, acquisition, or use of goods, products, or materials produced in the United States (including but not limited to iron, aluminum, steel, cement, and other manufactured products).

## **20. CLEAN AIR ACT**

Clean Air Act (42 U.S.C. 7401 et seq.) and the Federal Water Pollution Control Act (33 U.S.C. 1251 et seq.), as amended – Firms and subgrants of amounts in excess of \$100,000 shall contain a provision that requires the recipient to agree to comply with all applicable standards, orders or regulations issued pursuant to the Clean Air Act (42 U.S.C. 7401 et seq.) and the Federal Water Pollution Control Act as amended (33 U.S.C. 1251 et seq.) Violations shall be reported to the Federal awarding agency and the Regional Office of the Environmental Protection Agency (EPA).

## **21. CONFORMANCE WITH FEDERAL, STATE, AND LOCAL LAWS**

Federal, State and Local Laws: Services of a project as a result of the use of a Firm's services including the letting of subcontracts in connection with any project work related to this RFQ may be required to conform to the applicable requirements of Federal, State and local laws and ordinances. The City stipulates that Federal funds may be involved.

## **22. MAINTENANCE OF RECORDS**

Federal, State and Local Laws: Services of a project as a result of the use of a Firm's services including the letting of subcontracts in connection with any project work related to this RFQ may be required to conform to the applicable requirements of Federal, State and local laws and ordinances. The City stipulates that Federal funds may be involved.

## **23. CONFERENCE ROOMS**

Conference Rooms: All space used for conferences, meetings, conventions, or training seminars funded in whole or in part with federal funds under this contract must comply with the protection and controlling guidelines of the Hotel and Motel Fire Safety Act (PL 101-391, as amended).

## **24. AMERICANS WITH DISABILITIES ACT INFORMATION (ADA)**

Americans with Disabilities Act (42 U.S.C. 12101, et seq.). The Applicant shall comply with the provisions of the Americans with Disabilities Act, 42 U.S.C. 12101, et. seq. That Act provides a comprehensive national mandate to eliminate discrimination against individuals with disabilities. The Act may impose requirements on the Applicant in four principle ways: 1) with respect to employment; 2) with respect to the provision of public services; 3) with respect to transportation; 4) with respect to existing facilities and new construction.

The City in accordance with Section 504 of the Rehabilitation Act of 1973 and the Americans with Disabilities Act (ADA) commits to nondiscrimination in all of its programs and activities. The Firm agrees to comply with, and to require that all subcontractors comply with, Section 504 of the Rehabilitation Act of 1973 and the Americans with Disabilities Act, as applicable to the Firm.

Law Against Discrimination, Chapter 49.60 RCW. The Applicant shall comply with the provisions of Chapter 49.60 RCW in all activities relating to this Grant Agreement.

This material can be made available in an alternate format by request through ProcureWare question tab or by calling (509) 625-6400.

## **25. TITLE VI STATEMENT**

The City of Spokane in accordance with Title VI of the Civil Rights Act of 1964, 78 Stat. 252, 42 USC 2000d to 2000d-4 and Title 49, Code of Federal Regulations, Department of Transportation, Subtitle A, Office of the Secretary, Part 21, Nondiscrimination in Federally-Assisted Programs of the Department of Transportation issued pursuant to such Act, hereby notifies all Proposers that it will affirmatively ensure that in any contract entered into pursuant to this advertisement, disadvantaged business enterprises as defined at 49 CFR Part 26 will be afforded full opportunity to submit Proposals in response to this invitation and will not be discriminated against on the grounds of race, color, national origin, or sex in consideration for an award.

Public Law 88 - 352, Title VI of the Civil Rights Act of 1964 (42 U.S.C. 2000d et seq.) (24 CFR Part 1). The Applicant must comply with the provisions of "Public Law 88 - 352," which refers to Title VI of the Civil Rights Act of 1964 (42 U.S.C. 2000d et seq.). The law provides that no person in the United States shall, on the grounds of race, color or national origin, be denied the benefits of, be excluded from participation in, or be subjected to discrimination under any program or activity receiving federal financial assistance.



# Contractors

## Bozco Construction LLC

### Owner or tradesperson

#### Principals

Bozin, Pete S, PARTNER/MEMBER

BOZHINOVA, LYUBOV, PARTNER/MEMBER

(End: 09/21/2016)

BOZIN, VICTORIA, PARTNER/MEMBER

(End: 12/12/2023)

#### Doing business as

**Bozco Construction LLC**

#### WA UBI No.

**603 050 025**

#### PO Box 662

**Mead, WA 99021**

**509-499-1387**

**SPOKANE County**

#### Business type

**Limited Liability Company**

#### Governing persons

**VICTORIA**

#### BOZIN

PETE S BOZIN;

LYUBOV S BOZHINOVA;

LYUBOV BOZHINOVA;

PETE BOZIN;

VICTORIA BOZIN;

## Registration

Verify the contractor's active registration / license / certification (depending on trade) and any past violations.

### Construction Contractor

#### Active

**Meets current requirements.**

#### License specialties

**GENERAL**

#### License no.

**BOZCOCL905PL**

#### Effective — expiration

**10/13/2010— 10/28/2024**

#### L&I Contractor Registration:

**1-800-647-0982 - Email: ContReg@Lni.wa.gov**

### Bond

**American Contractors Indem CO**

**\$12,000.00**

#### Bond account no.

**100162517**

#### Received by L&I

**05/03/2011**

#### Effective date

**05/09/2011**

#### Expiration date

**Until Canceled**

### Insurance

**Country Mutual Ins Co**

**\$1,000,000.00**

#### Policy no.

**AM9393568**

#### Received by L&I

**06/12/2024**

#### Effective date

**06/06/2024**

#### Expiration date

**06/06/2025**

Cincinnati Ins Co \$1,000,000.00

Policy no.  
EPP0436211

Received by L&I  
03/13/2024

Effective date  
04/27/2019  
Expiration date  
04/27/2025

#### Insurance history

##### Savings

No savings accounts during the previous 6 year period.

##### Lawsuits against the bond or savings

No lawsuits against the bond or savings accounts during the previous 6 year period.

##### L&I Tax debts

No L&I tax debts are recorded for this contractor license during the previous 6 year period, but some debts may be recorded by other agencies.

##### License Violations

No license violations during the previous 6 year period.

## Certifications & Endorsements

##### OMWBE Certifications

No active certifications exist for this business.

##### Apprentice Training Agent

No active Washington registered apprentices exist for this business. Washington allows the use of apprentices registered with Oregon or Montana. Contact the Oregon Bureau of Labor & Industries or Montana Department of Labor & Industry to verify if this business has apprentices.

## Workers' Comp

Do you know if the business has employees? If so, verify the business is up-to-date on workers' comp premiums.

L&I Account ID  
164,642-01

Account is current.

Doing business as

BOZCO CONSTRUCTION. LLC

Estimated workers reported

Quarter 2 of Year 2024 "1 to 3 Workers"

L&I account contact

T0 / MICHELE GARRETT (360) 902-4620 - Email: GAMI235@lni.wa.gov

## Public Works Requirements

Verify the contractor is eligible to perform work on public works projects.

##### Required Training– Effective July 1, 2019

Exempt from this requirement.

##### Contractor Strikes

No strikes have been issued against this contractor.

##### Contractors not allowed to bid

No debarments have been issued against this contractor.

## Workplace Safety & Health

Check for any past safety and health violations found on jobsites this business was responsible for.

No inspections during the previous 6 year period.

**Agenda Sheet for City Council:****Committee:** PIES **Date:** 10/21/2024**Committee Agenda type:** Consent**Date Rec'd**

10/22/2024

**Clerk's File #**

OPR 2024-0940

**Cross Ref #****Project #****Council Meeting Date:** 11/04/2024**Submitting Dept**

FACILITIES MANAGEMENT

**Bid #**

PW ITB 6219-24

**Contact Name/Phone**

DAVE STEELE 625-6064

**Requisition #****Contact E-Mail**

DSTEELE@SPOKANECITY.ORG

**Agenda Item Type**

Contract Item

**Council Sponsor(s)**

BWILKERSON JBINGLE KKLITZKE

**Agenda Item Name**

5900 FACILITIES WATER DEPT MAIN BLDG REHAB &amp; REST - ELECTRICAL WORK

**Agenda Wording**

The Facilities Department in partnership with the Water Department has completed the procurement process for early electrical infrastructure work. This will complete the installation of a variety of electrical equipment necessary for the project.

**Summary (Background)**

The Facilities Dept along with the Water Dept and Purchasing, has completed the procurement process for early electrical infrastructure work. This work completes the installation of new electrical transformer pads, equipment specific auto transformers, and new switchgear on multiple building on Water Dept campus. This contract is with a local contractor, Colvico, Inc. 2812 N. Pittsburg St, Spokane WA. Base bid is \$269,460.08 plus the 10% admin fee is \$26,946.01 for a total of \$296,406.09.

Lease? NO

Grant related? NO

Public Works? YES

**Fiscal Impact**

Approved in Current Year Budget? YES

Total Cost \$ 296,406.09

Current Year Cost \$ 296,406.09

Subsequent Year(s) Cost \$

**Narrative**

Base bid is \$269,406.08 plus 10% administrative fee of \$26,946.01 for a total of \$296,406.09 before sales tax.

**Amount****Budget Account**

Expense \$ 269,460.08

# 4100-42490-94340-56501-11027

Expense \$ 26,946.01

# 4100-42490-94340-56501-11027

Select \$

#

Select \$

#

\$

#

\$

#



**Continuation of Wording, Summary, Approvals, and Distribution**

**Agenda Wording**

**Summary (Background)**

**Approvals**

<b><u>Dept Head</u></b>	TEAL, JEFFREY
<b><u>Division Director</u></b>	BOSTON, MATTHEW
<b><u>Accounting Manager</u></b>	ALBIN-MOORE, ANGELA
<b><u>Legal</u></b>	HARRINGTON,
<b><u>For the Mayor</u></b>	PICCOLO, MIKE

**Additional Approvals**

<b><u>PURCHASING</u></b>	PRINCE, THEA

**Distribution List**

Cory Colvin ccolvin@colvicoinc.com	dsteELE@spokanecity.org
klong@spokanecity.org	laga@spokanecity.org
kbustos@spokanecity.org	lsear1@spokanecity.org

## Committee Agenda Sheet

### Public Infrastructure, Environment & Sustainability Committee

<b>Submitting Department</b>	Facilities Department
<b>Contact Name</b>	Dave Steele
<b>Contact Email &amp; Phone</b>	509-625-6064
<b>Council Sponsor(s)</b>	CP BWilkerson, CM JBingle, CM Kklitzke
<b>Select Agenda Item Type</b>	<input checked="" type="checkbox"/> Consent <input type="checkbox"/> Discussion    Time Requested:
<b>Agenda Item Name</b>	Water Department Main Building Rehabilitation and Restoration - Early Electrical Work
<b>Summary (Background)</b>  *Use the Fiscal Impact box below for relevant financial information	The Facilities Department in partnership with the Water Department has completed the procurement process for early electrical infrastructure work. This work completes the installation of new electrical transformer pads, equipment specific auto transformers, and new switchgear on multiple building on the Water Department Campus. This contract is with Colvico Inc. 2812 N. Pittsburg St, Spokane, WA 99202.
<b>Proposed Council Action</b>	Contract approval
<b>Fiscal Impact</b>	
Total Expense:	<b>\$ 296,406.09 Plus Applicable Tax</b>
<b>Base bid:</b>	<b>\$ 269,460.08</b>
Administrative Reserve (10%)	<u>\$ 26,946.01</u>
Total	<b>\$ 296,406.09 Plus Applicable Tax</b>
Approved in current year budget?	<input checked="" type="checkbox"/> Yes <input type="checkbox"/> No <input type="checkbox"/> N/A
Funding Source	<input checked="" type="checkbox"/> One-time <input type="checkbox"/> Recurring <input type="checkbox"/> N/A
Specify funding source:	<b>4100-42490-94340-56501-11027</b>
Expense Occurrence	<input checked="" type="checkbox"/> One-time <input type="checkbox"/> Recurring <input type="checkbox"/> N/A
What impacts would the proposal have on historically excluded communities?	
NA	
How will data be collected, analyzed, and reported concerning the effect of the program/policy by racial, ethnic, gender identity, national origin, income level, disability, sexual orientation, or other existing disparities?	

NA

How will data be collected regarding the effectiveness of this program, policy, or product to ensure it is the right solution?

NA

Describe how this proposal aligns with current City Policies, including the Comprehensive Plan, Sustainability Action Plan, Capital Improvement Program, Neighborhood Master Plans, Council Resolutions, and others?

This project represents a significant re-investment in an existing City Facility with the intent of extending the useful life



City of Spokane  
**PUBLIC WORKS AGREEMENT**  
Title: **ELECTRICAL SUPPLY UPGRADE**

This Agreement is made and entered into by and between the **CITY OF SPOKANE** as (“City”), a Washington municipal corporation, and **COLVICO, INC.**, whose address is PO Box 2682, Spokane, Washington 99202, as (“Contractor”), individually hereafter referenced as a “Party”, and together as the “Parties”.

1. PERFORMANCE. The Contractor will do all work, furnish all labor, materials, tools, construction equipment, transportation, supplies, supervision, organization and other items of work and costs necessary for the proper execution and completion of the work described in the specifications entitled **SPOKANE WATER DEPARTMENT ELECTRICAL SUPPLY UPGRADE, PW ITB 6219-24 (see Exhibit B)**.
2. CONTRACT DOCUMENTS. The Contract documents are this Contract, the Contractor’s completed bid proposal form, unit price bid forms, contract provisions, contract plans & specifications & appendices, standard specifications, standard plans, addenda, City of Spokane invitation to bid, various certifications and affidavits, supplemental agreements, change orders and subsurface boring logs (if any). In the event of a conflict between these documents, PW Invitation to Bid shall be used to determine prevailing contract document. These contract documents are on file in the Water Department and are incorporated into this Contract by reference as if they were set forth at length. In the event of a conflict, or to resolve an ambiguity or dispute, federal and state requirements supersede this Contract, and this Contract supersedes the other contract documents.
3. TIME OF PERFORMANCE. The time of performance of the Contract shall begin on November 11, 2024, and shall run through October 31, 2025. Project time of completion and working days in accordance with contract documents.
4. LIQUIDATED DAMAGES. Liquidated damages shall be in accordance with the contract documents.
5. TERMINATION. Either party may terminate this Contract by thirty (30) days written notice to the other party. In the event of such termination, the City shall pay the Contractor for all work previously authorized and performed prior to the termination date.
6. COMPENSATION. Total compensation for Contractor’s services under this Contract shall be a maximum amount not to exceed **TWO HUNDRED SIXTY-NINE THOUSAND FOUR HUNDRED SIXTY AND 08/100 DOLLARS (\$269,460.08)**, plus applicable taxes, unless modified by a written amendment to this Contract. This is the maximum amount to be paid under this Contract for the work described in Section 2 above, and shall not be exceeded without the prior written authorization of the City in the form of an executed amendment to this Contract.

7. PAYMENT. The Contractor will send its applications for payment to the City of Spokane Facilities Management Department, facilitiesdepartment@spokanecity.org, Attn: Dave Steele. All invoices should include the Department Contract No. "OPR 2024-XXXX" and an approved L & I Intent to Pay Prevailing Wage number. The final invoice should include an approved Affidavit of Wages Paid number. Payment will not be made without this documentation included on the invoice. **Payment will be made via direct deposit/ACH** within thirty (30) days after receipt of the Company's application except as provided by state law. Five percent (5%) of the Contract price may be retained by the City, in accord with RCW 60.28 for a minimum of forty five (45) days after final acceptance, as a trust fund for the protection and payment of: the claims of any person arising under the Contract; and the State with respect to taxes imposed pursuant to Titles 50, 51 and 82 RCW which may be due from the Contractor.

8. INDEMNIFICATION. The Contractor shall defend, indemnify, and hold the City and its officers and employees harmless from all claims, demands, or suits at law or equity asserted by third parties for bodily injury (including death) and/or property damage which arise from the Contractor's negligence or willful misconduct under this Agreement, including attorneys' fees and litigation costs; provided that nothing herein shall require a Contractor to indemnify the City against and hold harmless the City from claims, demands or suits based solely upon the negligence of the City, its agents, officers, and employees. If a claim or suit is caused by or results from the concurrent negligence of the Contractor's agents or employees and the City, its agents, officers and employees, this indemnity provision shall be valid and enforceable to the extent of the negligence of the Contractor, its agents or employees. The Contractor specifically assumes liability and agrees to defend, indemnify, and hold the City harmless for actions brought by the Contractor's own employees against the City and, solely for the purpose of this indemnification and defense, the Contractor specifically waives any immunity under the Washington State industrial insurance law, or Title 51 RCW. The Contractor recognizes that this waiver was specifically entered into pursuant to the provisions of RCW 4.24.115 and was the subject of mutual negotiation. The indemnity and agreement to defend and hold the City harmless provided for in this section shall survive any termination or expiration of this agreement.

9. BONDS. The Contractor may not commence work until it obtains all insurance, permits and bonds required by the contract documents and applicable law. This includes the execution of a performance bond and a payment bond on the forms attached, each equal to one hundred percent (100%) of the contract price, and written by a corporate surety company licensed to do business in Washington State.

10. INSURANCE. During the period of the Agreement, the Contractor shall maintain in force at its own expense, each insurance noted below with companies or through sources approved by the State Insurance Commissioner pursuant to Title 48 RCW:

A. **Worker's Compensation Insurance** in compliance with RCW 51.12.020, which requires subject employers to provide workers' compensation coverage for all their subject workers and Employer's Liability Insurance in the amount of \$1,000,000;

B. **General Liability Insurance** on an occurrence basis, with a combined single limit of not less than \$1,000,000 each occurrence for bodily injury and property damage. It shall include contractual liability coverage for the indemnity provided under this agreement. It shall provide that the City, its officers and employees are additional insureds but only with respect to the Contractor's services to be provided under this Agreement;



- i. Acceptable supplementary Umbrella coverage in combination with Commercial General Liability policy shall be a minimum of \$2M in order to meet the minimum insurance coverages required under this contract;

C. **Automobile Liability Insurance** with a combined single limit, or the equivalent of not less than \$1,000,000 each accident for bodily injury and property damage, including coverage for owned, hired and non-owned vehicles; and

D. **Property Insurance** if materials and supplies are furnished by the Contractor. The amount of the insurance coverage shall be the value of the materials and supplies of the completed value of improvement. Hazard or XCU (explosion, collapse, underground) insurance should be provided if any hazard exists.

There shall be no cancellation, material change, or intent not to renew the insurance coverage(s) without thirty (30) days written notice from the Contractor or its insurer(s) or insurers authorized representative to the City. As evidence of the insurance coverages required by this Agreement, the Contractor shall furnish ACORD form insurance certificates to the City at the time it returns the signed Agreement. The certificate shall specify all of the parties who are additional insureds to the extent of Company's indemnify obligations, and include applicable blanket-form policy endorsements, including the blanket-form notice of cancellation endorsements (30 days). The Contractor shall be financially responsible for all pertinent deductibles, self-insured retentions, and/or self-insurance.

11. **CONTRACTOR'S WARRANTY.** The Contractor's warranty for all work, labor and materials shall be in accordance with the contract documents.

12. **WAGES.** The Contractor and all subcontractors will submit a "Statement of Intent to Pay Prevailing Wages" certified by the industrial statistician of the Department of Labor and Industries, prior to any payments. The "Statement of Intent to Pay Prevailing Wages" shall include: (1) the Contractor's registration number; and (2) the prevailing wages under RCW 39.12.020 and the number of workers in each classification. Each voucher claim submitted by the Contractor for payment on a project estimate shall state that the prevailing wages have been paid in accordance with the "Statement(s) of Intent to Pay Prevailing Wages" on file with the City. Prior to the payment of funds held under RCW 60.28, the Contractor and subcontractors must submit an "Affidavit of Wages Paid" certified by the industrial statistician.

13. **STATEMENT OF INTENT TO PAY PREVAILING WAGES TO BE POSTED.** The Contractor and each subcontractor required to pay the prevailing rate of wages shall post in a location readily visible at the job site: (1) a copy of a "Statement of Intent to Pay Prevailing Wages" approved by the industrial statistician of the State Department of Labor and Industries; and (2) the address and telephone number of the industrial statistician of the Department of Labor and Industries where a complaint or inquiry concerning prevailing wages may be made.

14. **PUBLIC WORKS REQUIREMENTS.** The Contractor and each subcontractor are required to fulfill the Department of Labor and Industries Public Works and Prevailing Wage Training Requirement under RCW 39.04.350. The contractor must verify responsibility criteria for each first tier subcontractor, and a subcontractor of any tier that hires other subcontractors must verify the responsibility criteria listed in RCW 39.04.350(1) for each of its subcontractors. Verification shall include that each subcontractor, at the time of subcontract execution, meets the responsibility criteria. This verification requirement, as well as responsibility criteria, must be included in every public works contract and subcontract of every tier.

15. SUBCONTRACTOR RESPONSIBILITY.

A. The Contractor shall include the language of this section in each of its first tier subcontracts, and shall require each of its subcontractors to include the same language of this section in each of their subcontracts, adjusting only as necessary the terms used for the contracting parties. Upon request of the City, the Contractor shall promptly provide documentation to the City demonstrating that the subcontractor meets the subcontractor responsibility criteria below. The requirements of this section apply to all subcontractors regardless of tier.

B. At the time of subcontract execution, the Contractor shall verify that each of its first tier subcontractors meets the following bidder responsibility criteria:

1. Have a current certificate of registration in compliance with chapter 18.27 RCW, which must have been in effect at the time of subcontract bid submittal;
2. Have a current Washington Unified Business Identifier (UBI) number;
3. If applicable, have:
  - a. Have Industrial Insurance (workers' compensation) coverage for the subcontractor's employees working in Washington, as required in Title 51 RCW;
  - b. A Washington Employment Security Department number, as required in Title 50 RCW;
  - c. A Washington Department of Revenue state excise tax registration number, as required in Title 82 RCW;
  - d. An electrical contractor license, if required by Chapter 19.28 RCW;
  - e. An elevator contractor license, if required by Chapter 70.87 RCW.
4. Not be disqualified from bidding on any public works contract under RCW 39.06.010 or 39.12.065 (3).

C. On Public Works construction projects, as defined in RCW 39.04.010, with an estimated cost of six hundred thousand dollars (\$600,000) or more, at least fifteen (15) percent of the labor hours on each project shall be performed by apprentices enrolled in a State-approved apprenticeship program; and for each contract in the project fifteen (15) percent of the labor hours for each craft that has an available state-approved apprenticeship program for Spokane County and utilizes more than one hundred sixty (160) hours in each contract shall be performed by apprentices enrolled in a state-approved apprenticeship program.

1. Subcontracting Requirements. The utilization percentages for apprenticeship labor for Public Works construction contracts shall also apply to all subcontracts of one hundred thousand dollars (\$100,000) or more within those contracts, and at least fifteen percent (15%) of the labor hours for each such subcontract shall be performed by apprentices in a state-approved apprenticeship program. For each craft that has an available apprenticeship program for Spokane county and performs more than one hundred sixty (160) hours on each project, fifteen (15) percent of the labor hours shall be performed by apprentices enrolled in a State-approved apprenticeship program.
2. Each subcontractor which this chapter applies is required to execute a form, provided by the city, acknowledging that the requirements of Article X 07.06 SMC are

applicable to the labor hours for the project.

16. NONDISCRIMINATION. No individual shall be excluded from participation in, denied the benefit of, subjected to discrimination under, or denied employment in the administration of or in connection with this Contract because of age, sex, race, color, religion, creed, marital status, familial status, sexual orientation including gender expression or gender identity, national origin, honorably discharged veteran or military status, the presence of any sensory, mental or physical disability, or use of a service animal by a person with disabilities. The Contractor agrees to comply with, and to require that all subcontractors comply with, Section 504 of the Rehabilitation Act of 1973 and the Americans with Disabilities Act, as applicable to the Contractor.

17. EXECUTIVE ORDER 11246.

- A. The Contractor will not discriminate against any employee or applicant for employment because of race, color, religion, sex or national origin. The Contractor will take affirmative action to insure that applicants are employed, and that employees are treated during employment, without regard to their race, color, religion, sex or national origin. Such action shall include but not be limited to the following: employment upgrading, demotion or transfer; recruitment or recruitment advertising; layoff or termination; rates of pay or other forms of compensation; and selection for training, including apprenticeship. The Contractor agrees to post in conspicuous places, available to employees and applicants for employment, notices to be provided by the contracting officer setting forth the provisions of this nondiscrimination clause.
- B. The Contractor will, in all solicitations or advertisements for employees placed by or on behalf of the Contractor, state that all qualified applicants will receive consideration for employment without regard to race, color, religion, sex or national origin.
- C. The Contractor will send each labor union, or representative of workers with which it has a collective bargaining contract or other contract or understanding, a notice, to be provided by the agency contracting officer, advising the labor union or workers' representative of the Contractor's commitments under Section 202 of Executive Order No. 11246 of September 24, 1965, and shall post copies of the notice in conspicuous places available to employees and applicants for employment.
- D. The Contractor will comply with all provisions of Executive Order No. 11246 of September 24, 1965, and of the rules, regulations, and relevant orders of the Secretary of Labor.
- E. The Contractor will furnish all information and reports required by Executive Order No. 11246 of September 24, 1965, and by the rules, regulations and orders of the Secretary of Labor, or pursuant thereto, and will permit access to its books, records, and accounts by the contracting agency and the Secretary of Labor for purposes of investigation to ascertain compliance with such rules, regulations and orders.
- F. In the event of the Contractor's noncompliance with the nondiscrimination clauses of this Contract or with any of such rules, regulations or orders, this Contract may be canceled, terminated or suspended in whole or in part, and the Contractor may be declared ineligible for further government contracts in accordance with procedures authorized in Executive Order No. 11246 of September 24, 1965, and such other sanctions may be imposed and remedies invoked as provided in Executive Order No. 11246 of September 24, 1965, or by rule, regulation, or order of the Secretary of Labor, or as otherwise provided by law.
- G. The Contractor will include the provisions of paragraphs A through G in every subcontract or purchase order unless exempted by rules, regulations or orders of the Secretary of Labor issued pursuant to Section 204 of Executive Order No. 11246 of September 24, 1965, so that such provisions will be binding upon each subcontractor or vendor. The Contractor will take such action with respect to any subcontract or purchase order as may be directed by the

Secretary of Labor as a means of enforcing such provisions including sanctions for noncompliance: PROVIDED, HOWEVER, that in the event the Contractor becomes involved in, or is threatened with, litigation with a subcontractor or vendor as the result of such direction, the Contractor may request the United States to enter into such litigation to protect the interests of the United States.

18. DEBARMENT AND SUSPENSION. The Contractor has provided its certification that it is in compliance with and shall not contract with individuals or organizations which are debarred, suspended, or otherwise excluded from or ineligible from participation in Federal Assistance Programs under Executive Order 12549 and "Debarment and Suspension", codified at 29 CFR part 98.

19. ASSIGNMENTS. The Contractor may not assign, transfer or sublet any part of the work under this Contract, or assign any monies due, without the written approval of the City, except as may be required by law. In the event of assignment of accounts or monies due under this Contract, the Contractor specifically agrees to give immediate written notice to the City Administrator, no later than five (5) business days after the assignment.

20. ANTI-KICKBACK. No officer or employee of the City of Spokane, having the power or duty to perform an official act or action related to this Contract shall have or acquire any interest in the Contract, or have solicited, accepted or granted a present or future gift, favor, service or other thing of value from or to any person involved in the Contract.

21. COMPLIANCE WITH LAWS. Each party shall comply with all applicable federal, state, and local laws and regulations that are incorporated herein by reference.

22. DISPUTES. This Contract shall be performed under the laws of the State of Washington. Any litigation to enforce this Contract or any of its provisions shall be brought in Spokane County, Washington.

23. SEVERABILITY. In the event any provision of this Contract should become invalid, the rest of the Contract shall remain in full force and effect.

24. AUDIT / RECORDS. The Contractor and its subcontractors shall maintain for a minimum of three (3) years following final payment all records related to its performance of the Contract. The Contractor and its subcontractors shall provide access to authorized City representatives, at reasonable times and in a reasonable manner to inspect and copy any such record. In the event of conflict between this provision and related auditing provisions required under federal law applicable to the Contract, the federal law shall prevail.

25. BUSINESS REGISTRATION REQUIREMENT. Section 8.01.070 of the Spokane Municipal Code states that no person may engage in business with the City without first having obtained a valid annual business registration. The Contractor shall be responsible for contacting the State of Washington Business License Services at [www.dor.wa.gov](http://www.dor.wa.gov) or 360-705-6741 to obtain a business registration. If the Contractor does not believe it is required to obtain a business registration, it may contact the City's Taxes and Licenses Division at (509) 625-6070 to request an exemption status determination.

26. CONSTRUAL. The Contractor acknowledges receipt of a copy of the contract documents and agrees to comply with them. The silence or omission in the contract documents concerning any detail required for the proper execution and completion of the work means that only the best general



**PAYMENT BOND**

We, **COLVICO, INC.**, as principal, and \_\_\_\_\_, as surety, are held and firmly bound to the City of Spokane, Washington, in the sum of **TWO HUNDRED SIXTY-NINE THOUSAND FOUR HUNDRED SIXTY AND 08/100 DOLLARS (\$269,460.08)**, plus applicable taxes plus applicable taxes, the payment of which, we bind ourselves and our legal representatives and successors, jointly and severally by this document.

The principal has entered into a contract with the City of Spokane, Washington, to do all work and furnish all materials for the **SPOKANE WATER DEPARTMENT ELECTRICAL SUPPLY UPGRADE, PW ITB 6219-24**. If the principal shall:

- A. pay all laborers, mechanics, subcontractors, material suppliers and all person(s) who shall supply such person or subcontractors; and pay all taxes and contributions, increases and penalties as authorized by law; and
- B. comply with all applicable federal, state and local laws and regulations;

then this obligation shall be null and void; otherwise it shall remain in full force and effect.

The Surety for value received agrees that no change, extension of time, alteration or addition to the terms of the Contract, the specifications accompanying the Contract, or to the work to be performed under the Contract shall in any way affect its obligation on this bond, except as provided herein, and waives notice of any change, extension of time, alteration or addition to the terms of the Contract or the work performed. The Surety agrees that modifications and changes to the terms and conditions of the Contract that increase the total amount to be paid the Principal shall automatically increase the obligation of the Surety on this bond and notice to Surety is not required for such increased obligation... Any judgment obtained against the City, which relates to or is covered by the contract or this bond, shall be conclusive against the principal and the surety, as to the amount of damages, and their liability, if reasonable notice of the suit has been given.

SIGNED AND SEALED on \_\_\_\_\_.

**COLVICO, INC.**  
AS PRINCIPAL

By: \_\_\_\_\_  
Title: \_\_\_\_\_

\_\_\_\_\_,  
AS SURETY

A valid POWER OF ATTORNEY  
for the Surety's agent must  
accompany this bond.

By: \_\_\_\_\_  
Its Attorney in Fact



**PERFORMANCE BOND**

We, **COLVICO, INC.**, as principal, and \_\_\_\_\_, as Surety, are held and firmly bound to the City of Spokane, Washington, in the sum of **TWO HUNDRED SIXTY-NINE THOUSAND FOUR HUNDRED SIXTY AND 08/100 DOLLARS (\$269,460.08)**, plus applicable taxes, for the payment of which, we bind ourselves and our legal representatives and successors, jointly and severally by this document.

The principal has entered into a Contract with the City of Spokane, Washington, to do all the work and furnish all materials for the **SPOKANE WATER DEPARTMENT ELECTRICAL SUPPLY UPGRADE, PW ITB 6219-24**. If the principal shall:

- A. promptly and faithfully perform the Contract, and any contractual guaranty and indemnify and hold harmless the City from all loss, damage or claim which may result from any act or omission of the principal, its agents, employees, or subcontractors; and
- B. comply with all applicable federal, state and local laws and regulations;

then this obligation shall be null and void; otherwise it shall remain in full force and effect.

The Surety for value received agrees that no change, extension of time, alteration or addition to the terms of the Contract, the specifications accompanying the Contract, or to the work to be performed under the Contract shall in any way affect its obligation on this bond, except as provided herein, and waives notice of any change, extension of time, alteration or addition to the terms of the Contract or the work performed. The Surety agrees that modifications and changes to the terms and conditions of the Contract that increase the total amount to be paid the Principal shall automatically increase the obligation of the Surety on this bond and notice to Surety is not required for such increased obligation. Any judgment obtained against the City, which relates to or is covered by the Contract or this bond, shall be conclusive against the principal and the Surety, not only as to the amount of damages, but also as to their liability, if reasonable notice of the suit has been given.

SIGNED AND SEALED on \_\_\_\_\_

**COLVICO, INC.**  
AS PRINCIPAL

By: \_\_\_\_\_  
Title: \_\_\_\_\_

\_\_\_\_\_,  
AS SURETY

By: \_\_\_\_\_  
Its Attorney in Fact

A valid POWER OF ATTORNEY  
for the Surety's agent must  
accompany this bond.



STATE OF WASHINGTON            )  
  ) ss.  
County of \_\_\_\_\_            )

I certify that I know or have satisfactory evidence that \_\_\_\_\_  
\_\_\_\_\_ signed this document; on oath stated that  
he/she was authorized to sign the document and acknowledged it as the agent or representative of the  
named Surety Company which is authorized to do business in the State of Washington, for the uses  
and purposes mentioned in this document.

DATED on \_\_\_\_\_.

\_\_\_\_\_  
Signature of Notary

My appointment expires \_\_\_\_\_

Approved as to form:

\_\_\_\_\_  
Assistant City Attorney

**CERTIFICATION REGARDING DEBARMENT, SUSPENSION,  
INELIGIBILITY AND VOLUNTARY EXCLUSION**

1. The undersigned (i.e., signatory for the Subrecipient / Contractor / Consultant) certifies, to the best of its knowledge and belief, that it and its principals:
  - a. Are not presently debarred, suspended, proposed for debarment, declared ineligible, or voluntarily excluded from covered transactions by any federal department or agency;
  - b. Have not within a three-year period preceding this contract been convicted or had a civil judgment rendered against them for commission of fraud or a criminal offense in connection with obtaining, attempting to obtain, or performing a public (federal, state, or local) transaction or contract under a public transaction; violation of federal or state antitrust statutes or commission of embezzlement, theft, forgery, bribery, falsification or destruction of records, making false statements, tax evasion, receiving stolen property, making false claims, or obstruction of justice;
  - c. Are not presently indicted or otherwise criminally or civilly charged by a government entity (federal, state, or local) with commission of any of the offenses enumerated in paragraph (1)(b) of this certification; and,
  - d. Have not within a three-year period preceding this contract had one or more public transactions (federal, state, or local) terminated for cause or default.
2. The undersigned agrees by signing this contract that it shall not knowingly enter into any lower tier covered transaction with a person who is debarred, suspended, declared ineligible, or voluntarily excluded from participation in this covered transaction.
3. The undersigned further agrees by signing this contract that it will include the following clause, without modification, in all lower tier covered transactions and in all solicitations for lower tier covered transactions:

Certification Regarding Debarment, Suspension, Ineligibility and Voluntary Exclusion – Lower Tier Covered Transactions

1. The lower tier contractor certified, by signing this contract that neither it nor its principals is presently debarred, suspended, proposed for debarment, declared ineligible, or voluntarily excluded from participation in this transaction by any federal department or agency.
  2. Where the lower tier contractor is unable to certify to any of the statements in this contract, such contractor shall attach an explanation to this contract.
4. I understand that a false statement of this certification may be grounds for termination of the contract.

<hr style="border: none; border-top: 1px solid black; margin-bottom: 5px;"/> Name of Subrecipient / Contractor / Consultant (Type or Print)	<hr style="border: none; border-top: 1px solid black; margin-bottom: 5px;"/> Program Title (Type or Print)
<hr style="border: none; border-top: 1px solid black; margin-bottom: 5px;"/> Name of Certifying Official (Type or Print)	<hr style="border: none; border-top: 1px solid black; margin-bottom: 5px;"/> Signature
<hr style="border: none; border-top: 1px solid black; margin-bottom: 5px;"/> Title of Certifying Official (Type or Print)	<hr style="border: none; border-top: 1px solid black; margin-bottom: 5px;"/> Date (Type or Print)

EXHIBIT B

## Bid Response Summary

**Bid Number** PW ITB 6219-24  
**Bid Title** Spokane Water Department Electrical Supply Upgrade (Re-Bid)  
**Due Date** Monday, September 30, 2024 1:00:00 PM [(UTC-08:00) Pacific Time (US & Canada)]  
**Bid Status** Closed to Bidding  
**Company** Colvico Inc  
**Submitted By** npritchett@colvicoinc.com npritchett@colvicoinc.com - Monday, September 30, 2024 10:30:06 AM [(UTC-08:00) Pacific Time (US & Canada)]  
 npritchett@colvicoinc.com 5092525822  
**Comments**

### Question Responses

Group	Reference Number	Question	Response
PRE-BID MEETING - MANDATORY			
	MANDATORY PRE-BID MEETING	A MANDATORY pre-bid meeting will be held on Thursday, September 12, 2024, at 9:00 am & Thursday, September 19th at 9:00 am at the City of Spokane Water Department Main Office - 914 East North Foothills Drive, Spokane, WA. Only those vendors who attend the Mandatory Pre-Bid Conference will be able to bid on this project.	I acknowledge and I understand
GENERAL INFORMATION			
	CONTRACTOR'S REPRESENTATIONS	The Contractor by making its Bid represents that it has read and understands the specifications; and has visited the site and familiarized itself with the local conditions under which the Work is to be performed.	I acknowledge and agree
	AWARD OF CONTRACT	Award of contract, when made by the City, will be to the low responsive-responsible bidder based on cost. Unsuccessful Contractors will not automatically be notified of results.	I acknowledge and agree
	CONTRACT RENEWALS	Contract renewals or extensions may be initiated by the City of Spokane, subject to mutual agreement	I acknowledge and I agree
	EXECUTION OF CONTRACT	Within ten (10) days of contract award the Contractor shall sign and return to the City an executed copy of the contract unless otherwise mutually agreed by the City and Contractor.	I acknowledge and I agree
	GUARANTEE	The Contractor guarantees all work, labor and materials for one (1) year following final acceptance. If any unsatisfactory condition or defect develops within that time, the Contractor shall immediately place the work in a satisfactory condition, and further repair all damage caused by the condition or defect at its sole expense. This guarantee shall not apply to work which has been abused or neglected by the City.	I acknowledge and I agree
	PAYMENT	Payment will be made via direct deposit/ACH after receipt of the Contractor's application except as provided by state law. If the City objects to all or any portion of the invoice, it shall notify the Contractor and reserves the right to only pay that portion of the invoice not in dispute. In that event, the parties shall immediately make every effort to settle the disputed amount.	I acknowledge and agree

REJECTION OF BIDS	The City reserves the right to reject any or all Bids, to waive minor deviations from the specifications, to waive minor informalities in the Bid process whenever it is in the City's best interest, and to accept or reject all or part of this Invitation to Bids, at the prices shown.	I acknowledge and agree
CONTRACTOR REGISTRATION	The Contractor shall be a Washington State registered or licensed Contractor at time of Bid submittal.	I acknowledge and agree
COMPLETION TIME	The bidder agrees to start the work under this contract within ten (10) days of the Notice to Proceed and to substantially complete the specified work within six (6) months.	I acknowledge and I agree
LIQUIDATED DAMAGES	If the Work is not completed within the stated completion time, the Contractor agrees to pay to the City liquidated damages in the amount zero (0) for each and every calendar day the work remains uncompleted. Which is a reasonable forecast of the damages likely to occur if Works is unfinished by the completion date.	I acknowledge and agree
MISCELLANEOUS DOCUMENTATION UPLOAD	Upload any additional documentation here. You can only upload one document so if you have more than one page - combine them into one page before uploading.	
PUBLIC WORKS REQUIREMENTS		
1.	The work under this contract constitutes a public work under state law.	I acknowledge and agree
2.	Payment/performance bonds will be required.	I acknowledge and agree
PERFORMANCE BONDS	The Contractor shall furnish, at its sole expense, a performance and payment bond equal to one hundred percent (100%) of the contract price. The bond shall insure faithful and complete performance of the contract and payment of all obligations to laborers and material men arising from the Project. The bond shall be executed by a Surety company authorized to do business in Washington State, and shall remain in effect for one (1) year following final acceptance of the work. Unless approved by the City, the Surety's name shall appear on the United States Treasury Department's list of authorized Sureties - Circular 570. On contracts of \$150,000.00 or less, in lieu of a surety bond, at the request of the Contractor, the City may retain ten percent (10%) of the contract price for a minimum of forty five (45) days following final acceptance, or until receipt of all releases and settlement of liens, whichever is later, in accord with RCW 39.08010.	I acknowledge and agree
3.	Statutory retainage will be required	I acknowledge and I understand
RETAINAGE	Pursuant to chapter 60.28 RCW, the City will retain five percent (5%) (or ten percent (10%) at Contractor's request) from the monies earned by the Contractor. This Retainage shall be held as a trust fund for the protection and payment: (1) to the State of taxes and fees owed by the Contractor; and (2) of any person, mechanic, subcontractor or material man who performs labor or furnishes any supplies toward the Work. Release of Retainage will be made at a minimum of forty five (45) days following final acceptance of Work; provided the following conditions are met:	I acknowledge and I agree

RETAINAGE	<p>a. The City has received from the Contractor and each subcontractor a copy of the "Statement of Intent to Pay Prevailing Wages" and an "Affidavit of Wages Paid", approved by the State Department of Labor and Industries (L&amp;I). b. On Contracts greater than \$35,000, the City has received releases from the State Departments of Revenue (DOR), Labor &amp; Industries and Employment Security. c. No claims, as provided by law, have been filed against the retainage In the event a claim is filed, the Contractor shall be paid a portion of the Retainage, which is less than the amount sufficient to pay the claim and potential legal costs.</p>	I acknowledge and I agree
4.	<p>The State prevailing rate of wages to be paid to all workmen, laborers or mechanics employed in the performance of any part of this Contract shall be in accordance with the provisions of Chapter 39.12 of the Revised Code of Washington (RCW) and the rules and regulations of the Washington State Department of Labor and Industries (L &amp; I).</p>	I acknowledge and I understand
5.	<p>The State of Washington prevailing wage rates applicable for this public works project, which is located in Spokane County, may be found at the following website address of the Department of Labor and Industries:  <a href="https://fortress.wa.gov/lni/wagelookup/prvWagelookup.aspx">https://fortress.wa.gov/lni/wagelookup/prvWagelookup.aspx</a>.  Based on the bid submittal deadline for this project, the applicable effective date for prevailing wages for this project is September 23, 2024.</p>	I acknowledge and I understand
6.	<p>If apprentices are to be used, they must be registered with the State Apprenticeship Council; otherwise, they are to be paid State prevailing journeyman wages.</p>	I acknowledge and I understand
7.	<p>The Contractor and any subcontractors will submit a <input type="checkbox"/>Statement of Intent to Pay Prevailing Wages<input type="checkbox"/> certified by the industrial statistician of the Department of Labor and Industries, prior to any work or payments. The <input type="checkbox"/>Statement of Intent to Pay Prevailing Wages<input type="checkbox"/> shall include: (1) the Contractor's registration number; and (2) the prevailing wages under RCW 39.12.020 and the number of workers in each classification. Prior to payment of funds held under RCW 39.12.040, the Contractor and subcontractors must submit an <input type="checkbox"/>Affidavit of Wages Paid<input type="checkbox"/> certified by the industrial statistician annually for all work completed within the previous twelve-month period of the unit priced contract (RCW 35.22.620).</p>	I acknowledge and I understand
8.	<p>The Contractor is responsible for payment of fees for the approval of "Statements of Intent to Pay Prevailing Wages" and "Affidavits of Wages Paid" and shall make all applications directly to L&amp;I.</p>	I acknowledge and I understand
9.	<p>As of July 1, 2019 contractors must have fulfilled the Department of Labor and Industries' Public Works and Prevailing Wage Training Requirement before bidding and/or performing work on public works projects under RCW 39.04.350 and RCW 39.06.020</p>	I acknowledge and I understand
TECHNICAL REQUIREMENTS		

SCOPE OF WORK	<p>The City of Spokane Water Department, in partnership with City Facilities desires to complete site electrical supply upgrades at the City of Spokane Water Department's Main campus located on the southeast corner of Hamilton Street and North Foothills Drive at 914 East North Foothills Drive. Contractor shall be responsible for all permits, inspections, labor, materials, equipment, safety measures, and proper disposal required to complete this work per the bid package plans and specifications. Contractor shall install all equipment per manufacturers specifications in conjunction with attached plans and specifications, and in compliance with all warranty requirements. Upon completion of work, Contractor shall provide a closeout package including warranty information and recommended preventative maintenance. All site access shall be coordinated through the Water Department in advance.</p>	I acknowledge and I agree
a.	What is the delivery timeline for the materials/equipment needed for this project	Panelboards are the long lead item at 12 weeks from submittal approval.
GENERAL REQUIREMENTS		
INTENT OF SPECIFICATIONS	<p>The apparent silence or omission in the specifications as to any detail of the Work to be done or materials to be furnished means that the region's best general practice shall prevail, and that material and workmanship of the best quality shall be used. The specifications shall be interpreted on this basis.</p>	I acknowledge and agree
WASHINGTON STATE RETAIL SALES TAX	<p>A. GENERAL CONSTRUCTION. Retail sales tax, when applicable, will be paid as a separate item, and shall not be included in the Bid price. Sales tax shall be added on the amount due the Contractor and the Contractor shall be responsible for making payment to the State. The City reserves the right to claim an exemption authorized by law.</p>	I acknowledge and agree
WASHINGTON STATE RETAIL SALES TAX	<p>B. PUBLIC STREET IMPROVEMENTS. If the technical requirements in the specifications indicate that all or a portion of the Work is a "public street improvement" as defined by state law, the Contractor shall include all contractor-paid taxes, including use taxes on materials in its Bid price. The City will NOT pay retail sales tax as a separate item.</p>	I acknowledge and agree
PERMITS	<p>Contractor shall be responsible for all permits, signage, equipment, materials and labor, demolition, dust control, reinstallation of all fixtures as needed, and clean up to complete this work in accordance with industry standards governing this type of work.</p>	I acknowledge and agree
GUARANTY	<p>The Contractor guarantees all work, labor and materials for one (1) year following final acceptance of the Work. If any unsatisfactory condition or defect develops within that time, the Contractor shall immediately place the Work in a satisfactory condition, and further repair all damage caused by the condition or defect at its sole expense. This guarantee shall not apply all Work, which has been abused or neglected by the City.</p>	I acknowledge and agree

SUBCONTRACTORS	The Contractor shall not award any portion of the Work to any subcontractor without the City's prior approval. The Contractor shall be fully responsible to the City for the acts, errors and omissions of its subcontractors. No contractual relationship shall be created between any subcontractor and the City.	I acknowledge and agree
INSURANCE	During the term of the Contract, the Contractor shall maintain in force at its own expense, the below insurance coverage(s):	I acknowledge and agree
INSURANCE	a. Worker's Compensation Insurance in compliance with RCW 51.12.020 which requires subject employers to provide worker's compensation coverage for all their subject workers and Employer's Liability Insurance in the amount of \$1,000,000.00.	I acknowledge and agree
INSURANCE	b. General Liability Insurance on an occurrence basis, with a combined single limit of not less than \$1,000,000.00 for bodily injury and property damage. It shall include premises and operations, independent contractors, products and completed operations, personal injury liability, and contractual liability coverage for the indemnity provided under the contract. It shall provide that the City, its officers and employees are additional insureds but only with respect to the Contractor's services to be provided under the contract; i. Acceptable supplementary Umbrella insurance coverage, combined with the Contractor's General Liability Insurance policy must be a minimum of \$1,500,000.00 in order to meet the insurance coverages required under this Contract;	I acknowledge and agree
INSURANCE	c. Property Insurance if materials and supplies are furnished by the Contractor. The amount of the insurance coverage shall be the value of the materials and supplies or the completed value of the improvement. Hazard or XCU (Explosion, Collapse, Underground) Insurance should be provided if any hazard exists; and	I acknowledge and agree
INSURANCE	d. Automobile Liability Insurance with a combined single limit, or the equivalent of not less than \$1,000,000.0 each accident for bodily injury and property damage, including coverage for owned, hired and non-owned vehicles.	I acknowledge and agree
INSURANCE	There shall be no cancellation, material change, reduction of limits or intent not to renew the insurance coverage(s) without thirty (30) days written notice from the Company or its insurer(s) to the City. As evidence of the insurance coverage(s) required by this Agreement, the Company shall furnish acceptable Certificates of Insurance (COI) upon request by the City. The certificate shall specify the City of Spokane as "Additional Insured" specifically for Company's services under this Agreement, as well as all of the parties who are additional insureds, and include applicable policy endorsements, the thirty (30) day cancellation clause, and the deduction or retention level. The Company shall be financially responsible for all pertinent deductibles, self-insured retentions, and/or self-insurance.	I acknowledge and agree
BID		



BIDDER'S DECLARATION	The Bidder submitting this bid certifies that it has examined the site, read and understands the specifications for the above project, and agrees to comply with all applicable federal, state and local laws and regulations. The bidder is advised that by submitting this bid proposal it has acknowledged all bid requirements and certifications contained herein.	I acknowledge and I agree
BID PRICE IS COMPLETE	Bidder acknowledges that the bid price indicated on the Pricing Page includes ALL expenses with regard to this project. No other costs will be allowed over and above the bid price.	I acknowledge and I agree
CONTRACTOR RESPONSIBILITY	Washington State Contractor's Registration Number	COLVII*134D6
CONTRACTOR RESPONSIBILITY	U.B.I. Number	601 009 703
CONTRACTOR RESPONSIBILITY	Washington Employment Security Department Number	620619 00-0
CONTRACTOR RESPONSIBILITY	Washington Excise Tax Registration Number	91-1363502
CONTRACTOR RESPONSIBILITY	City of Spokane Business Registration Number	T11102804BUS
ADDENDA	Bidder acknowledges receipt of ____ addenda and agrees that their requirements have been included in this bid proposal.	1 & amp; amp; 2
MISCELLANEOUS	The firm agrees that its Bid will NOT be withdrawn for a minimum of forty-five (45) calendar days after the stated submittal date.	I acknowledge and I agree
MISCELLANEOUS	For contracts up to \$150,000.00 including tax, the Contractor may request a 10 percent (10%) retainage in lieu of bond.	Yes
MISCELLANEOUS	If this project is less than \$150,000 - does contract request 10% retainage in lieu of bond?	
MISCELLANEOUS	The bidder submitting this response hereby certifies that, within the three-year period immediately preceding the bid solicitation date for this Project, the bidder is not a "willful" violator, as defined in RCW 49.48.082, of any provision of chapters 49.46, 49.48 or 49.52 RCW, as determined by a final and binding citation and notice of assessment issued by the Department of Labor and Industries or through a civil judgement entered by a court of limited or general jurisdiction. I certify (or declare) under penalty of perjury under the laws of the State of Washington that the foregoing is true and correct.	I acknowledge and I agree
MISCELLANEOUS	Individual's Name, Company Name, Address, Email Address & Phone Number for individual/company submitting this bid response.	Natalie Pritchett Colvico, Inc. PO Box 2682, Spokane, WA 99220 509-536-1875 npritchett@colvicoinc.com
MISCELLANEOUS	Name and Email Address for individual authorized to sign a contract.	Cory Colvin ccolvin@colvicoinc.com
1	Please complete the Bid Proposal document in the 'Documents' tab and upload here.	Bid Proposal Colvico Inc.pdf

2	The bid shall be accompanied by a bid bond bound to the City of Spokane, in an amount of not less than five percent (5%) of the total bid amount. Bid bonds must be by a surety company authorized to do business as a surety in Washington State. If the bidder is awarded the contract and fails to enter into a construction contract and/or furnish payment/performance bond(s) and proof of insurance within the required time period, the bid security shall be forfeited to the City of Spokane. Please upload your bid bond here (blank form available under the 'Documents' tab).	Bid Bond Colvico Inc.pdf
3	If subcontractors will be used, please download the 'Subcontractor List' document from the 'Documents' tab, complete, and upload the completed document here. If subcontractors will be used, failure to upload the completed list may result in a non-responsive determination to this request.	PW ITB #6219-24 Subcontractor List under \$1M.pdf
TERMS & CONDITIONS		
#1	Bidder accepts has read and acknowledges compliance with Terms and Conditions located in the Documents area of this project. If answer is "I do not acknowledge and I do not agree", include requested exception in proposal submittal on separate page and title as "Exception to Terms and Conditions". The City will consider and determine if exception will be accepted.	I acknowledge and I agree
#2	Describe exceptions to Terms & Conditions if you marked "I do not acknowledge and I do not agree" above.	N/A

### Pricing Responses

Group	Reference Number	Description	Type	Unit Of Measure	Quantity	Unit Price	Ext Base Price	Comment
BID								
	#1	Water Department Electrical Supply Upgrade Project	Base	ea	1.00	\$269,460.08	\$269,460.08	
	#2	9% Sales Tax	Base	ea	1.00	\$24,251.41	\$24,251.41	
<b>Total Base Bid</b>							\$293,711.49	

**BID PROPOSAL**

To: Honorable Mayor  
Members of the City Council  
City of Spokane, Washington

**PROJECT:** PW ITB #6219-24 Spokane Water Department Electrical Supply Upgrade (Re-Bid)

**BIDDER'S DECLARATION.**

The undersigned bidder certifies that it has examined the site, read and understands the specifications for the above project, and agrees to comply with all applicable federal, state and local laws and regulations. The bidder is advised that by signature of this bid proposal it has acknowledged all bid requirements and signed all certificates contained herein.

**BID OFFER.**

The price(s) listed in this bid proposal is tendered as an offer to furnish all labor, materials, equipment and supervision required to complete the proposed project in strict accordance with the contract documents. The bidder proposes to do the project at the following price:

BASE BID:	\$ 269,460.08
SALES TAX ( 9%)	\$ 24,251.41
TOTAL BASE PRICE:	\$: 293,711.49

**ADDENDA.**

The undersigned acknowledges receipt of addenda number(s) 1, 2 and agrees that their requirements have been included in this bid proposal.

**CONTRACT COMPLETION TIME.**

The bidder agrees to start the work under this contract within ten (10) days of the Notice to Proceed and to substantially complete the specified work within **six (6) months from the Notice To Proceed date.**

**LIQUIDATED DAMAGES.**

In the event the bidder is awarded the contract and fails to complete the work within the time limit or any agreed upon time extensions, liquidated damages shall be paid to the City of Spokane in the amount of ZERO DOLLARS (\$0.0) per working day until the work is satisfactorily completed.

**BIDDER RESPONSIBILITY.**

Washington State Contractor's Registration No. COLVII\*072JH  
(must be in effect at time of bid submittal)

U.B.I. Number 601 009 703

Washington Employment Security Department Number 620619 00-0

Washington Excise Tax Registration Number 91-1363502

City of Spokane Business License Number T11102804BUS

(The successful bidder and all subcontractors shall be licensed or have applied for a license to do business in the City of Spokane prior to proceeding with the proposed project.)

**BID SECURITY.**

A bid security in the amount of FIVE PERCENT (5%) of the total project bid as indicated above, is attached to this bid proposal. If the bidder is awarded the contract and fails to enter into a construction contract and/or furnish payment / performance bond(s) and proof of insurance within the required time period, the bid security shall be forfeited to the City of Spokane.

**NON-COLLUSION.**

The undersigned authorized representative of the undersigned firm, being first sworn on oath, certifies that the firm has not, directly or indirectly, entered into any agreement, participated in any collusion, or otherwise taken any action in restraint of free competitive bidding in connection with the project for which this bid proposal is submitted.

Name of Bidder: Colvico, Inc.

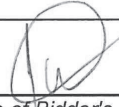

Signature of Bidder's Authorized Representative

Jesse Dragoo, Vice President

Title

PO Box 2682, Spokane, WA 99220

Address

509-536-1875

Phone

**IF INDIVIDUAL**

Signed and Sworn To (or Affirmed) Before Me On \_\_\_\_\_  
*date*

(Seal Or Stamp)

\_\_\_\_\_  
*Signature of Notary Public*

My appointment expires \_\_\_\_\_

**IF PARTNERSHIP**

I certify that I know or have satisfactory evidence that the above named person signed this bid proposal, on oath stated that he/she was authorized to sign it and acknowledged it as the partner(s) of the bidder, a partnership, to be the free and voluntary act of such party for the uses and purposes herein mentioned.

Signed and Sworn To (or Affirmed) Before Me On \_\_\_\_\_

date

(Seal Or Stamp)

\_\_\_\_\_  
Signature of Notary Public

My appointment expires \_\_\_\_\_

**IF CORPORATION**

I certify that I know or have satisfactory evidence that the above named person signed this bid proposal, on oath stated that he/she was authorized to sign it and acknowledged it as the representative of the bidder, a corporation, to be the free and voluntary act of such party for the uses and purposes herein mentioned.

Signed and Sworn To (or Affirmed) Before Me On September 30, 2024  
date

(Seal Or Stamp)

  
\_\_\_\_\_  
Signature of Notary Public

My appointment expires 7/31/24

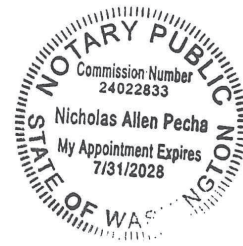

**SUBCONTRACTOR LIST**

**PROJECT NAME:** PW ITB #6219-24 Spokane Water Department Electrical Supply Upgrade (Re-Bid)

**IMPORTANT: REFER TO SECTION 5.2.1 OF THE SUPPLEMENTAL CONDITIONS FOR INSTRUCTIONS ON COMPLETING THE SUBCONTRACTOR LIST** *(use additional pages if necessary):*

**CONTRACTOR/SUPPLIER** Diamond Asphalt Paving, Inc.

TYPE OF WORK/BID ITEM Paving Patchback

AMOUNT \$5,000.00

CONTRACTOR'S REGISTRATION NO. DIAMOAP841DN

**CONTRACTOR/SUPPLIER** \_\_\_\_\_

TYPE OF WORK/BID ITEM \_\_\_\_\_

AMOUNT \_\_\_\_\_

CONTRACTOR'S REGISTRATION NO. \_\_\_\_\_

**CONTRACTOR/SUPPLIER** \_\_\_\_\_

TYPE OF WORK/BID ITEM \_\_\_\_\_

AMOUNT \_\_\_\_\_

CONTRACTOR'S REGISTRATION NO. \_\_\_\_\_

**CONTRACTOR/SUPPLIER** \_\_\_\_\_

TYPE OF WORK/BID ITEM \_\_\_\_\_

AMOUNT \_\_\_\_\_

CONTRACTOR'S REGISTRATION NO. \_\_\_\_\_

\_\_\_\_\_ NO SUBCONTRACTORS WILL BE USED ON THIS PROJECT

# Document A310™ – 2010

Conforms with The American Institute of Architects AIA Document 310

## Bid Bond

### CONTRACTOR:

(Name, legal status and address)

Colvico, Inc.  
2812 N. Pittsburg  
Spokane, WA 99207

### OWNER:

(Name, legal status and address)

City of Spokane  
221 W. First Avenue  
Spokane, WA 99202

### SURETY:

(Name, legal status and principal place of business)

Travelers Casualty and Surety Company of America  
One Tower Square  
Hartford, CT 06183  
Mailing Address for Notices  
818 W. Riverside Ave., Ste. 800  
Spokane, WA 99201

This document has important legal consequences. Consultation with an attorney is encouraged with respect to its completion or modification.

Any singular reference to Contractor, Surety, Owner or other party shall be considered plural where applicable.

**BOND AMOUNT:** 5% Five Percent of Amount Bid

### PROJECT:

(Name, location or address, and Project number, if any)

Spokane Water Department Electrical Supply Upgrade (Re-Bid), PW ITB 6219-24

The Contractor and Surety are bound to the Owner in the amount set forth above, for the payment of which the Contractor and Surety bind themselves, their heirs, executors, administrators, successors and assigns, jointly and severally, as provided herein. The conditions of this Bond are such that if the Owner accepts the bid of the Contractor within the time specified in the bid documents, or within such time period as may be agreed to by the Owner and Contractor, and the Contractor either (1) enters into a contract with the Owner in accordance with the terms of such bid, and gives such bond or bonds as may be specified in the bidding or Contract Documents, with a surety admitted in the jurisdiction of the Project and otherwise acceptable to the Owner, for the faithful performance of such Contract and for the prompt payment of labor and material furnished in the prosecution thereof; or (2) pays to the Owner the difference, not to exceed the amount of this Bond, between the amount specified in said bid and such larger amount for which the Owner may in good faith contract with another party to perform the work covered by said bid, then this obligation shall be null and void, otherwise to remain in full force and effect. The Surety hereby waives any notice of an agreement between the Owner and Contractor to extend the time in which the Owner may accept the bid. Waiver of notice by the Surety shall not apply to any extension exceeding sixty (60) days in the aggregate beyond the time for acceptance of bids specified in the bid documents, and the Owner and Contractor shall obtain the Surety's consent for an extension beyond sixty (60) days.

If this Bond is issued in connection with a subcontractor's bid to a Contractor, the term Contractor in this Bond shall be deemed to be Subcontractor and the term Owner shall be deemed to be Contractor.

When this Bond has been furnished to comply with a statutory or other legal requirement in the location of the Project, any provision in this Bond conflicting with said statutory or legal requirement shall be deemed deleted herefrom and provisions conforming to such statutory or other legal requirement shall be deemed incorporated herein. When so furnished, the intent is that this Bond shall be construed as a statutory bond and not as a common law bond.

Signed and sealed this 23rd day of September, 2024.

  
(Witness)

Colvico, Inc.  
(Principal) \_\_\_\_\_ (Seal)

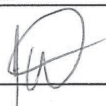
By:   
(Title)

  
(Witness) Shawn M. Wilson

Travelers Casualty and Surety Company of America  
(Surety) \_\_\_\_\_ (Seal)

By:   
(Title) Peggy A. Firth, Attorney-in-Fact





**Travelers Casualty and Surety Company of America**  
**Travelers Casualty and Surety Company**  
**St. Paul Fire and Marine Insurance Company**  
**Farmington Casualty Company**

**POWER OF ATTORNEY**

Travelers Casualty and Surety Company of America, Travelers Casualty and Surety Company, St. Paul Fire and Marine Insurance Company, and Farmington Casualty Company are corporations duly organized under the laws of the State of Connecticut (herein collectively called the "Companies"), and the Companies do hereby make, constitute and appoint Peggy A. Firth of Spokane, WA, their true and lawful Attorney(s)-in-Fact to sign, execute, seal and acknowledge any and all bonds, recognizances, conditional undertakings and other writings obligatory in the nature thereof on behalf of the Companies in their business of guaranteeing the fidelity of persons, guaranteeing the performance of contracts and executing or guaranteeing bonds and undertakings required or permitted in any actions or proceedings allowed by law.

IN WITNESS WHEREOF, the Companies have caused this instrument to be signed, and their corporate seals to be hereto affixed, this 4th day of March, 2024.



State of Connecticut

City of Hartford ss.

By:   
 Bryce Grissom, Senior Vice President

On this the 4th day of March, 2024, before me personally appeared Bryce Grissom, who acknowledged himself to be the Senior Vice President of each of the Companies, and that he, as such, being authorized so to do, executed the foregoing instrument for the purposes therein contained by signing on behalf of said Companies by himself as a duly authorized officer.

IN WITNESS WHEREOF, I hereunto set my hand and official seal.

My Commission expires the 30th day of June, 2026



  
 Anna P. Nowik, Notary Public

This Power of Attorney is granted under and by the authority of the following resolutions adopted by the Boards of Directors of each of the Companies, which resolutions are now in full force and effect, reading as follows:

**RESOLVED**, that the Chairman, the President, any Vice Chairman, any Executive Vice President, any Senior Vice President, any Vice President, any Second Vice President, the Treasurer, any Assistant Treasurer, the Corporate Secretary or any Assistant Secretary may appoint Attorneys-in-Fact and Agents to act for and on behalf of the Company and may give such appointee such authority as his or her certificate of authority may prescribe to sign with the Company's name and seal with the Company's seal bonds, recognizances, contracts of indemnity, and other writings obligatory in the nature of a bond, recognizance, or conditional undertaking, and any of said officers or the Board of Directors at any time may remove any such appointee and revoke the power given him or her; and it is

**FURTHER RESOLVED**, that the Chairman, the President, any Vice Chairman, any Executive Vice President, any Senior Vice President or any Vice President may delegate all or any part of the foregoing authority to one or more officers or employees of this Company, provided that each such delegation is in writing and a copy thereof is filed in the office of the Secretary; and it is

**FURTHER RESOLVED**, that any bond, recognizance, contract of indemnity, or writing obligatory in the nature of a bond, recognizance, or conditional undertaking shall be valid and binding upon the Company when (a) signed by the President, any Vice Chairman, any Executive Vice President, any Senior Vice President or any Vice President, any Second Vice President, the Treasurer, any Assistant Treasurer, the Corporate Secretary or any Assistant Secretary and duly attested and sealed with the Company's seal by a Secretary or Assistant Secretary; or (b) duly executed (under seal, if required) by one or more Attorneys-in-Fact and Agents pursuant to the power prescribed in his or her certificate or their certificates of authority or by one or more Company officers pursuant to a written delegation of authority; and it is

**FURTHER RESOLVED**, that the signature of each of the following officers: President, any Executive Vice President, any Senior Vice President, any Vice President, any Assistant Vice President, any Secretary, any Assistant Secretary, and the seal of the Company may be affixed by facsimile to any Power of Attorney or to any certificate relating thereto appointing Resident Vice Presidents, Resident Assistant Secretaries or Attorneys-in-Fact for purposes only of executing and attesting bonds and undertakings and other writings obligatory in the nature thereof, and any such Power of Attorney or certificate bearing such facsimile signature or facsimile seal shall be valid and binding upon the Company and any such power so executed and certified by such facsimile signature and facsimile seal shall be valid and binding on the Company in the future with respect to any bond or understanding to which it is attached.

I, Kevin E. Hughes, the undersigned, Assistant Secretary of each of the Companies, do hereby certify that the above and foregoing is a true and correct copy of the Power of Attorney executed by said Companies, which remains in full force and effect.

Dated this September 23, 2024



  
 Kevin E. Hughes, Assistant Secretary

To verify the authenticity of this Power of Attorney, please call us at 1-800-421-3880.  
 Please refer to the above-named Attorney(s)-in-Fact and the details of the bond to which this Power of Attorney is attached.







**License Information:**

[New search](#) [Back to results](#)

**Entity name:** COLVICO, INC.  
**Business name:** COLVICO, INC.  
**Entity type:** [Profit Corporation](#)  
**UBI #:** 601-009-703  
**Business ID:** 001  
**Location ID:** 0002  
**Location:** Active  
**Location address:** 2812 N PITTSBURG ST  
 SPOKANE WA 99207-4854  
**Mailing address:** PO BOX 2682  
 SPOKANE WA 99220-2682

**Excise tax and reseller permit status:** [Click here](#)

**Secretary of State status:** [Click here](#)

**Endorsements**

Endorsements held at this location	License #	Count	Details	Status	Expiration date	First issuance date
Liberty Lake General Business - Non-Resident				Active	Mar-31-2025	Jul-30-2021
Lynden General Business - Non-Resident				Active	Mar-31-2025	Aug-05-2020
Mill Creek General Business - Non-Resident				Active	Mar-31-2025	Jul-25-2023
Millwood General Business - Non-Resident				Active	Mar-31-2025	Jul-31-2023
Olympia General Business - Non-Resident	47393			Active	Mar-31-2025	Dec-13-2022
Pullman General Business - Non-Resident				Active	Sep-30-2025	Sep-19-2024
SeaTac General Business - Non-Resident				<a href="#">Active</a>	Mar-31-2025	Jun-12-2019
Soap Lake General Business - Non-Resident				Active	Mar-31-2025	Jul-26-2023
Spokane General Business	T11102804BUS			Active	Mar-31-2025	Oct-15-2012
Spokane Valley General Business - Non-Resident	02016			Active	Mar-31-2025	Mar-11-2004
Tukwila General Business - Non-Resident				Active	Mar-31-2025	Jul-25-2023
Union Gap General Business - Non-Resident				Active	Mar-31-2025	Mar-07-2023
Waterville General Business - Non-Resident				Active	Mar-31-2025	Aug-07-2023

Endorsements held at this location	License #	Count	Details	Status	Expiration date	First issuance date
Wenatchee General Business - Non-Resident				Active	Mar-31-2025	Aug-31-2022
Yakima General Business - Non-Resident	BL080013			Active	Mar-31-2025	Mar-23-2016
<b>Governing People</b> <small>May include governing people not registered with Secretary of State</small>						
Governing people			Title			
COLVIN, CORY S						
DRAGOO, JESSE R						
<b>Registered Trade Names</b>						
Registered trade names			Status		First issued	
COLVICO, INC			Active		Jun-08-2022	
<a href="#">View Additional Locations</a>						
The Business Lookup information is updated nightly. Search date and time: 10/10/2024 3:01:50 PM						

**Contact us**

How are we doing?

**Take our survey!**

Don't see what you expected?

**Check if your browser is supported**



**Agenda Sheet for City Council:**

**Committee:** Date: N/A

**Committee Agenda type:**

**Council Meeting Date:** 11/04/2024

<b>Date Rec'd</b>	10/29/2024
<b>Clerk's File #</b>	CPR 2024-0002
<b>Cross Ref #</b>	
<b>Project #</b>	
<b>Bid #</b>	
<b>Requisition #</b>	

<b>Submitting Dept</b>	ACCOUNTING & GRANTS
<b>Contact Name/Phone</b>	LEONARD 625-6028
<b>Contact E-Mail</b>	LDAVIS@SPOKANECITY.ORG
<b>Agenda Item Type</b>	Claim Item
<b>Council Sponsor(s)</b>	
<b>Agenda Item Name</b>	5600-CLAIMS THRU 10-25-2024

**Agenda Wording**

Report of the Mayor of pending claims & payments of previously approved obligations through: 10/25/2024. Total:\$7,183,538.73 with Parks & Library claims being approved by their respective boards. Claims excluding Parks & Library Total:\$6,677,171.27

**Summary (Background)**

Pages 1-24 Check numbers: 606522 - 606645 Credit Card numbers: 000812- 000832 ACH payment numbers: 134509 - 134698 On file for review in City Clerks Office: 24 Page listing of Claims Note:

Lease? NO Grant related? NO Public Works? NO

**Fiscal Impact**

Approved in Current Year Budget?

Total Cost	\$
Current Year Cost	\$
Subsequent Year(s) Cost	\$

**Narrative**

<b>Amount</b>	<b>Budget Account</b>
Expense \$ 6,677,171.27	# Various
Select \$	#
Select \$	#
Select \$	#
\$	#
\$	#



REPORT: PG3620  
SYSTEM: FMSAP  
USER: MANAGER  
RUN NO: 43

APPROVAL FUND SUMMARY

DATE: 10/28/24  
TIME: 08:17  
PAGE: 1

FUND	FUND NAME	AMOUNT
0100	GENERAL FUND	373,994.41
1100	STREET FUND	255,013.11
1200	CODE ENFORCEMENT FUND	3,291.65
1300	LIBRARY FUND	224.53
1360	MISCELLANEOUS GRANTS FUND	0.00
1380	TRAFFIC CALMING MEASURES	435,816.00
1400	PARKS AND RECREATION FUND	1,000.22
1425	AMERICAN RESCUE PLAN	323,329.62
1460	PARKING METER REVENUE FUND	1,702.59
1560	FORFEITURES & CONTRIBUTION FND	1,358.48
1620	PUBLIC SAFETY & JUDICIAL GRANT	2,509.34
1640	COMMUNICATIONS BLDG M&O FUND	17,222.00
1695	CDBG REVOLVING LOAN FUND	115.54
1910	CRIMINAL JUSTICE ASSISTANCE FD	3,105.46
1970	FIRE/EMS FUND	63,287.48
3200	ARTERIAL STREET FUND	358,546.16
4100	WATER DIVISION	778,501.69
4250	INTEGRATED CAPITAL MANAGEMENT	374,540.74
4300	SEWER FUND	315,020.26
4480	SOLID WASTE FUND	205,794.27
4600	GOLF FUND	553.10
4700	DEVELOPMENT SVCS CENTER	876.63
5100	FLEET SERVICES FUND	210,432.11
5200	PUBLIC WORKS AND UTILITIES	37,330.46
5300	IT FUND	8,537.33
5310	IT CAPITAL REPLACEMENT FUND	2,971.42
5750	OFFICE OF PERFORMANCE MGMT	8,051.25
5800	RISK MANAGEMENT FUND	95,865.68
5810	WORKERS' COMPENSATION FUND	79.42
5820	UNEMPLOYMENT COMPENSATION FUND	672,761.86
5830	EMPLOYEES BENEFITS FUND	1,196,528.16
5900	FACILITIES MANAGEMENT FUND OPS	97,202.53
5901	ASSET MANAGEMENT FUND CAPITAL	220,213.71
5903	PROPERTY ACQUISITION FIRE	10,805.23
6070	FIREFIGHTERS' PENSION FUND	76,291.69
6080	POLICE PENSION FUND	68,705.49
6255	LAW ENFORCEMENT RECORDS MGMT	31,746.50
	TOTAL:	6,253,326.12

REPORT: PG3640  
SYSTEM: FMSAP  
USER: MANAGER  
RUN NO: 43

CITY OF SPOKANE  
COUNCIL CHECK RANGE/TOTAL

DATE: 10/28/24  
TIME: 08:17  
PAGE: 1

CHECK #	VENDOR	CITY	LIBRARY	PARKS
	USE TAX AMOUNTS	1,197.69	2,650.41	
00606522	AMERICAN SPRINKLER REPAIR	817.50		
00606523	AT&T MOBILITY	6,150.63		
00606524	BOUND TREE MEDICAL LLC	150.81		
00606525	CENTURYLINK	5,919.44		
00606526	DEPT OF ARCHAEOLOGY & HISTOR	17,530.22		
00606527	CANENG STRUCTURAL CONSULTING	25.00		
00606528	HOLLISTER HOMES LLC	160.00		
00606529	ILLIA & SVETLANA BILOUS	100.00		
00606530	PLUMB ZEBRA & TURD NERDS	44.00		
00606531	RIGHT NOW HEATING AND COOLIN	45.00		
00606532	CATHOLIC CHARITIES	38.00		
00606533	PERMITIUM LLC	170.00		
00606534	PET EMERGENCY CLINIC	374.30		
00606535	POINTE PEST CONTROL	130.80		
00606536	ROTO-ROOTER/DIV OF	464.07		
00606537	SAFETY KLEEN CORPORATION	1,660.70		
00606538	SPOKANE COUNTY CLERK	246.00		
00606539	SPOKANE COUNTY CLERK	25.00		
00606540	T-MOBILE	29.75		
00606541	WA STATE DEPT OF LICENSING	8,187.00		
00606542	WA STATE DEPT OF LICENSING	90.00		
00606543	WA STATE DEPT OF LICENSING	4.64		
00606544	WA STATE DEPT OF REVENUE	25,722.39		
00606546	WHITWORTH WATER DISTRICT NO	129.40		
00606547	BRIAN V ZEHM	135.00		
00606548	CHRIS VALEO		150.00	
00606550	PATRICK HENNESSY	810.99		
00606551	POINTE PEST CONTROL	1,466.05		
00606552	COLIN QUINN-HURST	870.08		
00606553	SPOKANE CITY TREASURER OR	676,238.52		
00606554	PATRICK B WISE	229.81		
00606555	MERCHANTS NATIONAL BONDING I	190,706.62		
00606556	WA STATE EMPLOYMENT SECURITY	436,475.25		
00606557	WA STATE EMPLOYMENT SECURITY	236,286.61		
00606596	BIG JOHN MFG CO INC	11,930.00		
00606597	CENTURYLINK	10,369.98		
00606598	NORFOLK IRON & METAL CO	3,326.40		
00606599	COMCAST	520.10		
00606600	DS SERVICES OF AMERICA INC	98.91		
00606601	FIRST IMPRESSIONS CREATIVE	115.54		
00606602	BETHANY NEVAREZ	173.67		
00606603	B&A COLLECTIBLES INC	65.50		
00606604	ADVANCED FIRE SYSTEMS	76.00		
00606605	BLACK REALTY MANAGEMENT	19.00		
00606606	CATHOLIC CHARITIES OF SPOKAN	38.00		
00606607	GLOBAL FEDERAL CREDIT UNION	38.00		
00606608	OMNICARE LLC	8.04		
00606609	MARK C PROTHERO	650.00		
00606610	CHRIS PYLES	180.00		
00606611	SAFEGUARD BUSINESS SYSTEMS I	261.62		
00606612	SPOKANE REGIONAL HEALTH DIST	22,414.88		
00606613	ROBERT E STOFFREGEN MA PS	5,200.00		

REPORT: PG3640  
SYSTEM: FMSAP  
USER: MANAGER  
RUN NO: 43

CITY OF SPOKANE  
COUNCIL CHECK RANGE/TOTAL

DATE: 10/28/24  
TIME: 08:17  
PAGE: 2

CHECK #	VENDOR	CITY	LIBRARY	PARKS
00606614	SULLIVAN VENTURES, LLC	7,460.00		
00606615	SWANSON'S REFRIGERATION &	975.65		
00606616	T-MOBILE USA INC	50.00		
00606617	WA STATE DEPT OF ECOLOGY	2,269.00		
00606618	WA STATE DEPT OF LICENSING	10,503.00		
00606619	WA STATE DEPT OF LICENSING	165.00		
00606620	WA STATE DEPT OF LICENSING	210.00		
00606621	WELLTOWER PEGASUS TENNANT LL	8,931.00		
00606622	WESLEN CONSTRUCTION INC	63,012.39		
00606623	WM RECYCLE AMERICA LLC	128.77		
00606624	ALPINE NORTHWEST LLC		57,165.57	
00606625	SPOKANE PUBLIC LIBRARY IMPRE		700.00	
00606626	RIDGETOP			75,868.43
00606627	SAFETY KLEEN CORPORATION			304.53
00606628	DARREN WHITE	100.00		
00606629	A ACTIONTECH INC	228.90		
00606630	AMERICAN SPRINKLER REPAIR	975.55		
00606631	CENTURYLINK	403.94		
00606632	HIP OF SPOKANE COUNTY DBA	164,471.21		
00606633	EMERALD SERVICES INC	50.40		
00606634	LAWRENCE B STONE PROPERTIES	553.50		
00606635	SAFETY KLEEN CORPORATION	254.50		
00606636	US BANK	24,674.83		
00606637	WA STATE EMPLOYMENT SECURITY	63.50		
00606638	CENTURYLINK			410.51
00606639	CENTURYLINK COMMUNICATIONS I			516.07
00606640	COMCAST			188.38
00606641	COMCAST			188.38
00606642	COMCAST			198.01
00606643	COMCAST			698.96
00606644	PARK DEPT IMPREST FUND			112.47
00606645	PARK DEPT IMPREST FUND			117.29
70000812	ALASKA RUBBER GROUP INC	99.19		
70000813	NORTHWEST INDUSTRIAL SERVICE	159.63		
70000814	CINTAS CORPORATION	1,310.11	38.15	
70000815	GALLS LLC	690.76		
70000816	GORDON TRUCK CENTERS INC DBA	1,517.72		
70000817	NORCO INC	1,001.69		
70000818	OVERDRIVE INC		4,955.43	
70000819	SIGNS FOR SUCCESS INC	2,319.79		
70000820	SITEONE LANDSCAPE SUPPLY LLC	63.70		
70000821	PEROVICH PARTNERS INC	371.92		
70000822	ANATEK LABS INC	40.00		
70000823	CINTAS CORPORATION	12,267.03		
70000824	CORE92 INC	288.00		
70000825	EVERGREEN STATE TOWING LLC	370.60		
70000826	HYDRAULICS PLUS INC	2,378.76		
70000827	KERSHAW INC	775.67		
70000828	NORCO INC	128.12		
70000829	SPOKANE HOUSE OF HOSE INC	536.99		
70000830	WESTERN STATES EQUIPMENT CO	593.12		
70000831	NORTHWEST INDUSTRIAL SERVICE			1,005.00
70000832	EVERGREEN STATE TOWING LLC	734.66		

REPORT: PG3640  
SYSTEM: FMSAP  
USER: MANAGER  
RUN NO: 43

CITY OF SPOKANE  
COUNCIL CHECK RANGE/TOTAL

DATE: 10/28/24  
TIME: 08:17  
PAGE: 3

CHECK #	VENDOR	CITY	LIBRARY	PARKS
80134509	ACRANET CBS BRANCH/DIV OF	667.50		



80134510	ACTION MATERIALS	7,478.48	
80134511	ALSCO DIVISION OF ALSCO INC	119.74	
80134512	AMERICAN RADIATOR INC	10,210.96	
80134513	AVISTA CORPORATION	10,081.62	
80134514	AVISTA UTILITIES	27,497.44	
80134515	BAKER & TAYLOR BOOKS		5,938.17
80134516	CAMTEK INC	188.01	
80134517	CENGAGE LEARNING INC		778.19
80134518	CLARK'S CONTAINERS LLC	116.36	
80134519	COLEMAN OIL COMPANY LLC	75,969.32	
80134520	COLUMBIA ELECTRIC SUPPLY/DIV	3,349.03	
80134521	COMPUNET INC	1,448.94	
80134522	CONNELL OIL INC	310.67	
80134523	CONTROL SOLUTIONS NW INC	17,303.75	
80134524	COPIERS NORTHWEST INC	1,549.01	
80134525	DELL MARKETING LP	2,971.42	
80134526	ENNIS FLINT INC	42,150.30	
80134527	ERGON ASPHALT & EMULSIONS IN	3,608.31	
80134528	SHELLEY FAIRWEATHER-VEGA		174.40
80134529	FASTENAL CO	5,089.45	
80134530	GORLEY LOGISTICS LLC	66.54	
80134531	FIREPOWER INC	2,392.57	
80134532	INFINITE INNOVATIONS LLC	8,051.25	
80134533	INGRAM LIBRARY SERVICES LLC		688.01
80134534	CPM DEVELOPMENT CORP DBA	268,838.58	
80134535	KENWORTH SALES COMPANY	220,677.19	
80134536	LONG BUSINESS FORMS LLC	359.70	
80134537	LSB CONSULTING ENGINEERS PLL	187.50	
80134538	MIDWEST TAPE		696.16
80134539	CAR WASH PARTNERS LLC	175.00	
80134540	LEGEND INVESTMENTS CORP	73,394.06	
80134541	NELSON'S TOWING AND REPAIR/	276.86	
80134542	NORTH COUNTRY SERVICES LLC	821.84	
80134543	NW HANDLING SYSTEMS INC	1,143.96	
80134544	NW MUSEUM OF ARTS & CULTURE/	261.60	
80134545	OAC SERVICES INC	8,352.50	
80134546	OCCUPATIONAL HEALTH SOLUTION	2,011.00	
80134547	OTIS ELEVATOR COMPANY	2,643.24	
80134548	PARAMETRIX INC	46,838.75	
80134549	PERFORMANCE SYSTEMS	192.83	
80134550	POWERCOM.INC	6,814.69	
80134551	RAY TURF FARMS INC	176.42	
80134552	ANDREWS ENTERPRISES INC	207.65	
80134553	ROAR WORKS LLC	5,858.75	
80134554	SHAMROCK MANUFACTURING INC	54,137.56	
80134555	SHERWIN WILLIAMS CO	601.35	
80134556	SHI CORP	53.04	
80134557	SPECIALTY MOBILE MIX INC	632.20	
80134558	SPOKANE COUNTY TREASURER	76,478.68	
80134559	SPOKANE TOWING/DIV OF	207.65	
80134560	STARPLEX CORP	31,128.90	
80134561	STOP STICK LTD	2,054.65	

REPORT: PG3640  
SYSTEM: FMSAP  
USER: MANAGER  
RUN NO: 43

CITY OF SPOKANE  
COUNCIL CHECK RANGE/TOTAL

DATE: 10/28/24  
TIME: 08:17  
PAGE: 4

CHECK #	VENDOR	CITY	LIBRARY	PARKS
80134562	THOMSON WEST	10,649.08		
80134563	US BANK OR CITY TREASURER	93,254.68		
80134564	VERIZON WIRELESS	5,282.99		
80134565	VERTICAL OPTIONS LLC	348.80		
80134566	VESTIS GROUP INC	1,916.00		

80134567	WASHINGTON EQUIPMENT	3,052.00		
80134568	WCP SOLUTIONS		1,879.92	
80134569	WEST PLAINS AIRPORT AREA	159,758.05		
80134570	WILLIAMS TOWING & RECOVERY L	1,488.12		
80134571	JENNIE ANDERSON		23.79	
80134572	BRENDAN CRAIG	1,051.98		
80134573	DALTON KUHN	116.00		
80134574	DION MASON	1,940.00		
80134575	ALSCO DIVISION OF ALSCO INC			141.24
80134576	ARROW CONCRETE & ASPHALT	27,113.75		
80134577	COPIERS NORTHWEST INC			745.60
80134578	NORTHEAST YOUTH CENTER			11,628.17
80134579	PROJECT JOY			2,580.83
80134580	T W CLARK CONSTRUCTION LLC	59,171.74		
80134581	ADRIANO M EVA	98.16		
80134582	JOHN F GOODMAN	88.50		
80134583	DOUGLAS GREENLUND	583.19		
80134584	JONI MEYER	163.50		
80134585	ABM JANITORIAL SERVICES SOUT	5,478.82		
80134586	FOUR SEASONS SERVICES INC	3,816.09		
80134587	HRA VEBA TRUST	74,995.50		
80134588	LANDMARK STRUCTURES I LP	3,002.89		
80134589	LAWRENCE B STONE PROPERTIES	28,381.73		
80134590	MAX J KUNEY COMPANY	215,820.00		
80134591	NORTH COUNTRY SERVICES LLC	902.48		
80134592	PREMERA BLUE CROSS OR	914,528.07		
80134593	REHN & ASSOCIATES	1,000.00		
80134594	REVIVE COUNSELING SPOKANE PL	49,999.99		
80134595	THE SALVATION ARMY	22,026.39		
80134596	SPOKANE NEIGHBORHOOD ACTION	122,116.67		
80134597	SPOKANE FIRE FIGHTERS BENEFIT	16,500.00		
80134598	VOLUNTEERS OF AMERICA OF	200,798.12		
80134599	ABM JANITORIAL SERVICES SOUT	14,667.09		
80134600	ALLIANT INSURANCE SERVICES I	9,050.00		
80134601	ALSCO DIVISION OF ALSCO INC	1,725.40		
80134602	AVISTA UTILITIES	8,830.87	4,287.03	
80134603	BACON CONCRETE INC	362,379.43		
80134604	BRIGHT IDEA SHOPS			1,941.00
80134605	CASCADE COLUMBIA DISTRIBUTIO	1,744.00		
80134606	CDW GOVERNMENT INC	41.30		
80134607	STEVE CONNER			9,368.59
80134608	COPIERS NORTHWEST INC	6,056.76		
80134609	MATTHEW COWLES	3,219.00		
80134610	CREEK AT QUALCHAN GOLF COURSE			9,341.46
80134611	CUMMINS INC	244.86		
80134612	L N CURTIS & SONS	693.53		
80134613	D & L SUPPLY CO INC	25,887.50		
80134614	ANN DEASY	65.39		

REPORT: PG3640

CITY OF SPOKANE

DATE: 10/28/24

SYSTEM: FMSAP

COUNCIL CHECK RANGE/TOTAL

TIME: 08:17

USER: MANAGER

PAGE: 5

RUN NO: 43

CHECK #	VENDOR	CITY	LIBRARY	PARKS
80134615	GWP HOLDINGS LLC	23,473.51		
80134616	THE DRAIN SPECIALISTS	931.95		
80134617	ELECTRIC CITY INC			403.30
80134618	EUROFINS ENVIRONMENT TESTING	150.00		
80134619	FASTENAL CO	2,219.07		
80134620	FEDERAL EXPRESS CORP/DBA FED	170.66		
80134621	FISHER SCIENTIFIC	3,363.58		
80134622	GHS NORTHWEST LLC		29,449.00	
80134623	GRAINGER INC	4,749.73		

80134624	GROUNDWATER SOLUTIONS INC	60,037.78		
80134625	GROUP 4 ARCHITECTURE, RESEARC		5,017.20	
80134626	HASA INC	15,682.61		
80134627	HILL INTERNATIONAL INC		10,106.40	
80134628	HOTSY OF SPOKANE LLC	4,843.93		
80134629	KPFF CONSULTING ENGINEERS	19,589.95		
80134630	KYOCERA DOCUMENT SOLUTIONS	1,089.60		
80134631	LYNDA CARPENTER	211.25		
80134632	LEXIS-NEXIS RISK & ANALYTICS	163.50		
80134633	LIFE ASSIST INC	437.74		
80134634	LOOMIS ARMORED US INC	866.00		
80134635	NALCO CO	4,045.72		
80134636	NORTHWEST RIVER SUPPLIES INC	1,212.54		
80134637	OCCUPATIONAL HEALTH SOLUTION	668.00		
80134638	OIL RE-REFINING CO INC	206.25		
80134639	PARAMETRIX INC	7,973.90		
80134640	PERFORMANCE SYSTEMS			1,659.53
80134641	PETE LIEN & SONS INC	11,249.44		
80134642	POMP'S TIRE SERVICE INC	12,883.98		
80134643	PROVOST PROFESSIONAL	139.75		
80134644	SANDBAGGERS CLUB LLC			7,813.08
80134645	SAVEMORE BUILDING SUPPLY/DIV		212.36	
80134646	SHI CORP	312.48		
80134647	SPOKANE TREATMENT AND	9,841.69		
80134648	SPOKANE COUNTY TREASURER	2,452.79		
80134649	SPOKANE RESTAURANT EQUIPMENT	5,469.42		
80134650	SPRING ENVIRONMENTAL INC	2,300.00		
80134651	T & T GOLF MANAGEMENT INC			12,334.40
80134652	TOBY'S BODY & FENDER INC	10,111.70		
80134653	VERIZON WIRELESS	2,010.90		
80134654	VICTOR J GIAMPIETRI II	600.00		
80134655	WATERTRONICS LLC			142,836.00
80134656	THE BABCOCK & WILCOX COMPANY	404.61		
80134657	JAMES CULP	128.38		
80134658	GREGORY C HARSHMAN	65.00		
80134659	JESSICA A MCGREGOR	2,509.34		
80134660	STEPHANIE SIJOHN	100.00		
80134661	AHBL INC			11,220.10
80134662	SPOKANE ENVELOPE LLC	79.42		
80134663	ALSCO DIVISION OF ALSCO INC			4.58
80134664	AM HARDWARE CO	2,354.38		
80134665	AVISTA CORPORATION	26,090.73		
80134666	AVISTA UTILITIES			70,631.17
80134667	BUDINGER & ASSOCIATES INC			6,410.50

REPORT: PG3640  
SYSTEM: FMSAP  
USER: MANAGER  
RUN NO: 43

CITY OF SPOKANE  
COUNCIL CHECK RANGE/TOTAL

DATE: 10/28/24  
TIME: 08:17  
PAGE: 6

CHECK #	VENDOR	CITY	LIBRARY	PARKS
80134668	CANON SOLUTIONS AMERICA INC	5,117.55		
80134669	CARASOFT TECHNOLOGY CORP	798.67		
80134670	CDW GOVERNMENT INC	495.84		
80134671	COLEMAN OIL COMPANY LLC	65,742.11		
80134672	CONNELL OIL INC	2,093.62		
80134673	COPIERS NORTHWEST INC	3,504.11		886.27
80134674	DELTA DENTAL OF WASHINGTON	38,045.57		
80134675	GWP HOLDINGS LLC	230,808.69		
80134676	FIREPOWER INC	758.89		
80134677	FISHER CONSTRUCTION GROUP IN	1,226.25		
80134678	GRAINGER INC	132.40		
80134679	HALME CONSTRUCTION INC	62,561.20		
80134680	HILLYARD SENIOR ACTIVITY CTR			6,666.66

80134681	INNOVIA FOUNDATION	138,993.61		
80134682	INLAND POWER & LIGHT CO			122.71
80134683	KAISER FOUNDATION HEALTH PLA	233,683.14		
80134684	NONICA ANDREW DBA MARSHALLES	3,056.00		
80134685	NEW MARKETS TAX CREDIT	750.00		
80134686	NORTH COUNTRY SERVICES LLC	468.68		
80134687	NORTH DIVISION MUFFLER CLINI	168.95		
80134688	PLACE LANDSCAPE ARCHITECTURE			950.00
80134689	POMP'S TIRE SERVICE INC	25,982.57		
80134690	PREMERA BLUE CROSS OR	73,630.64		
80134691	SHAMROCK MANUFACTURING INC	60,950.42		
80134692	SPOKANE POLICE CHAPLAINCY	308.18		
80134693	COWLES PUBLISHING COMPANY	930.27		
80134694	BRYAN T HILL	218.00		
80134695	VERIZON WIRELESS			4,164.05
80134696	VERTICAL OPTIONS LLC	872.00		
80134697	VESTIS GROUP INC	377.08		
80134698	VOLT MANAGEMENT CORP	19,864.80		
		-----	-----	-----
		6,677,171.27	124,910.19	381,457.27
				=====
			CITYWIDE TOTAL:	7,183,538.73

REPORT: PG3630  
SYSTEM: FMSAP  
USER: MANAGER  
RUN NO: 43

DATE: 10/28/24  
TIME:  
PAGE: 1

HONORABLE MAYOR  
AND COUNCIL MEMBERS

10/28/24  
PAGE 2

PROCESSING OF VOUCHERS RESULTS IN CLAIMS AS FOLLOWS:

0020 - NONDEPARTMENTAL

SPOKANE TREATMENT AND RECOVERY SERVICES	CONTRACTUAL SERVICES ACH PMT NO. - 80134647	9,841.69
US BANK TREASURY MANAGEMENT SERVICES	EARNINGS CREDIT CHECK NO. - 00606636	429.85-
TOTAL FOR 0020 - NONDEPARTMENTAL		9,411.84

0030 - POLICE OMBUDSMAN

STARPLEX CORP	ALARM/SECURITY SERVICES ACH PMT NO. - 80134560	51.30
TOTAL FOR 0030 - POLICE OMBUDSMAN		51.30

0100 - GENERAL FUND

B&A COLLECTIBLES INC 741 MEDINA AVE	PERMIT REFUNDS PAYABLE CHECK NO. - 00606603	65.50
DEPT OF ARCHAEOLOGY & HISTORIC PRESERVATION	GRANT CASH PASS THRU ACCOUNT CHECK NO. - 00606526	17,530.22
HOLLISTER HOMES LLC PO BOX 524	PERMIT REFUNDS PAYABLE CHECK NO. - 00606528	160.00
LAWRENCE B STONE PROPERTIES #901 LLC	PERMIT REFUNDS PAYABLE CHECK NO. - 00606634	553.50
PERMITIUM LLC	ACCOUNTS RECEIVABLE-MISC CHECK NO. - 00606533	170.00
WA STATE DEPT OF REVENUE MISCELLANEOUS TAX DIVISION	DEPOSIT-LEASE EXCISE TAX CHECK NO. - 00606544	25,722.39
TOTAL FOR 0100 - GENERAL FUND		44,201.61

0320 - COUNCIL

STARPLEX CORP	OTHER MISC CHARGES ACH PMT NO. - 80134560	371.93
TOTAL FOR 0320 - COUNCIL		371.93

0370 - ENGINEERING SERVICES

ABM JANITORIAL SERVICES SOUTH SOUTH CENTRAL INC dba	LAUNDRY/JANITORIAL SERVICES ACH PMT NO. - 80134599	980.40
--	---	--------

HONORABLE MAYOR  
AND COUNCIL MEMBERS

10/28/24  
PAGE 3

PROCESSING OF VOUCHERS RESULTS IN CLAIMS AS FOLLOWS:

TOTAL FOR 0370 - ENGINEERING SERVICES		980.40
---------------------------------------	--	--------

0410 - FINANCE

-----		
SPOKANE COUNTY TREASURER	CONTRACTUAL SERVICES	
	ACH PMT NO. - 80134558	62,883.21
US BANK	BANK FEES	
TREASURY MANAGEMENT SERVICES	CHECK NO. - 00606636	3,056.66
US BANK	EARNINGS CREDIT	
TREASURY MANAGEMENT SERVICES	CHECK NO. - 00606636	1,304.92-
TOTAL FOR 0410 - FINANCE		----- 64,634.95

0470 - HISTORIC PRESERVATION

-----		
COWLES PUBLISHING COMPANY	ADVERTISING	
DBA THE SPOKESMAN-REVIEW	ACH PMT NO. - 80134693	930.27
TOTAL FOR 0470 - HISTORIC PRESERVATION		----- 930.27

0500 - LEGAL

-----		
ABM JANITORIAL SERVICES SOUTH	LAUNDRY/JANITORIAL SERVICES	
SOUTH CENTRAL INC dba	ACH PMT NO. - 80134599	988.55
THOMSON WEST	PUBLICATIONS	
WEST PUBLISHING PAYMENT CTR	ACH PMT NO. - 80134562	10,649.08
VERIZON WIRELESS	CELL PHONE	
	ACH PMT NO. - 80134564	85.58
TOTAL FOR 0500 - LEGAL		----- 11,723.21

0560 - MUNICIPAL COURT

-----		
LONG BUSINESS FORMS LLC	PRINTING/BINDING/REPRO	
	ACH PMT NO. - 80134536	359.70
SAFEGUARD BUSINESS SYSTEMS INC	OPERATING SUPPLIES	
	CHECK NO. - 00606611	261.62
SPOKANE COUNTY TREASURER	SPOKANE COUNTY	
	ACH PMT NO. - 80134558	613.07
US BANK	BANK FEES	
TREASURY MANAGEMENT SERVICES	CHECK NO. - 00606636	182.26
TOTAL FOR 0560 - MUNICIPAL COURT		----- 1,416.65

HONORABLE MAYOR  
AND COUNCIL MEMBERS

10/28/24  
PAGE 4

PROCESSING OF VOUCHERS RESULTS IN CLAIMS AS FOLLOWS:

0620 - HUMAN RESOURCES

-----		
ACRANET CBS BRANCH/DIV OF	BACKGROUND CHECKS	
CBS REPORTING INC	ACH PMT NO. - 80134509	71.50
TOTAL FOR 0620 - HUMAN RESOURCES		----- 71.50

0650 - PLANNING SERVICES

COLIN QUINN-HURST	LODGING CHECK NO. - 00606552	386.96
COLIN QUINN-HURST	OTHER TRANSPORTATION EXPENSES CHECK NO. - 00606552	392.62
COLIN QUINN-HURST	PER DIEM CHECK NO. - 00606552	90.50
SIGNS FOR SUCCESS INC	PRINTING/BINDING/REPRO CREDIT CARD PMT NO. - 70000819	724.86
TOTAL FOR 0650 - PLANNING SERVICES		1,594.94

0680 - POLICE

ABM JANITORIAL SERVICES SOUTH SOUTH CENTRAL INC dba	LAUNDRY/JANITORIAL SERVICES ACH PMT NO. - 80134585	5,478.82
ANDREWS ENTERPRISES INC RELIABLE TOWING EAST	TOWING EXPENSE ACH PMT NO. - 80134552	207.65
AT&T MOBILITY	CELL PHONE CHECK NO. - 00606523	6,150.63
AVISTA UTILITIES	UTILITY LIGHT/POWER SERVICE ACH PMT NO. - 80134602	8,317.04
AVISTA UTILITIES	UTILITY NATURAL GAS ACH PMT NO. - 80134602	441.46
COMCAST	IT/DATA SERVICES CHECK NO. - 00606599	164.34
COPIERS NORTHWEST INC	EQUIPMENT REPAIRS/MAINTENANCE ACH PMT NO. - 80134524	0.01
COPIERS NORTHWEST INC	OPERATING RENTALS/LEASES ACH PMT NO. - 80134673	7,896.45
DION MASON	TUITION REIMBURSEMENT ACH PMT NO. - 80134574	1,940.00
FOUR SEASONS SERVICES INC DBA FOUR SEASONS LANDSCAPING	LANDSCAPE/GROUNDS MAINT ACH PMT NO. - 80134586	3,816.09

HONORABLE MAYOR  
AND COUNCIL MEMBERS

10/28/24  
PAGE 5

PROCESSING OF VOUCHERS RESULTS IN CLAIMS AS FOLLOWS:

GORLEY LOGISTICS LLC dba FIKES NORTHWEST	OPERATING SUPPLIES ACH PMT NO. - 80134530	66.54
GRAINGER INC	OPERATING SUPPLIES ACH PMT NO. - 80134678	382.81
HRA VEBA TRUST HRA VEBA TRUST CONTRIBUTIONS	HRA-POST EMPLOYMENT ACH PMT NO. - 80134587	19,000.00
LEXIS-NEXIS RISK & ANALYTICS GROUP ACCURINT-ACCT 1189340	BACKGROUND CHECKS ACH PMT NO. - 80134632	163.50



LOOMIS ARMORED US INC	CONTRACTUAL SERVICES ACH PMT NO. - 80134634	866.00
MATTHEW COWLES	TUITION REIMBURSEMENT ACH PMT NO. - 80134609	3,219.00
NELSON'S TOWING AND REPAIR/ DIV OF NELCO SERVICES INC	TOWING EXPENSE ACH PMT NO. - 80134541	276.86
NW HANDLING SYSTEMS INC	EQUIPMENT REPAIRS/MAINTENANCE ACH PMT NO. - 80134543	719.40
NW HANDLING SYSTEMS INC	OPERATING SUPPLIES ACH PMT NO. - 80134543	424.56
PET EMERGENCY CLINIC	VETERINARY SERVICES CHECK NO. - 00606534	374.30
REHN & ASSOCIATES SPOKANE CITY TREASURER	HRA-POST EMPLOYMENT ACH PMT NO. - 80134593	1,000.00
ROBERT E STOFFREGEN MA PS	MEDICAL SERVICES CHECK NO. - 00606613	5,200.00
SPOKANE COUNTY TREASURER	SPOKANE COUNTY ACH PMT NO. - 80134558	180.90
SPOKANE POLICE CHAPLAINCY BOARD	NON-TRAVEL MEALS/LGHT RFRSHMT ACH PMT NO. - 80134692	308.18
SPOKANE TOWING/DIV OF NELCO SERVICES INC	TOWING EXPENSE ACH PMT NO. - 80134559	207.65
STOP STICK LTD	MINOR EQUIPMENT ACH PMT NO. - 80134561	2,054.65
T-MOBILE USA INC	MISC SERVICES/CHARGES CHECK NO. - 00606616	50.00
US BANK TREASURY MANAGEMENT SERVICES	BANK FEES CHECK NO. - 00606636	199.98
US BANK TREASURY MANAGEMENT SERVICES	EARNINGS CREDIT CHECK NO. - 00606636	15.86-
VERIZON WIRELESS	CELL PHONE ACH PMT NO. - 80134564	1,693.45

HONORABLE MAYOR  
AND COUNCIL MEMBERS

10/28/24  
PAGE 6

PROCESSING OF VOUCHERS RESULTS IN CLAIMS AS FOLLOWS:

VERIZON WIRELESS	MOBILE BROADBAND ACH PMT NO. - 80134564	602.44
VESTIS GROUP INC DBA VESTIS SERVICES INC	LAUNDRY/JANITORIAL SERVICES ACH PMT NO. - 80134697	2,293.08
WA STATE EMPLOYMENT SECURITY DEPARTMENT	MISC SERVICES/CHARGES CHECK NO. - 00606637	63.50
WILLIAMS TOWING & RECOVERY LLC	TOWING EXPENSE ACH PMT NO. - 80134570	1,488.12

TOTAL FOR 0680 - POLICE

-----  
75,231.55

0690 - COMMUNITY JUSTICE SERVICES

DS SERVICES OF AMERICA INC DBA CRYSTAL SPRINGS	OFFICE SUPPLIES CHECK NO. - 00606600	49.45
PATRICK HENNESSY	OTHER TRANSPORTATION EXPENSES CHECK NO. - 00606550	419.49
PATRICK HENNESSY	PER DIEM CHECK NO. - 00606550	391.50
TOTAL FOR 0690 - COMMUNITY JUSTICE SERVICES		860.44

0700 - PUBLIC DEFENDER

ABM JANITORIAL SERVICES SOUTH SOUTH CENTRAL INC dba	LAUNDRY/JANITORIAL SERVICES ACH PMT NO. - 80134599	979.77
LYNDA CARPENTER DBA LC INVESTIGATIONS LLC	LEGAL SERVICES ACH PMT NO. - 80134631	211.25
MARK C PROTHERO	LEGAL SERVICES CHECK NO. - 00606609	650.00
PROVOST PROFESSIONAL INVESTIGATIONS	LEGAL SERVICES ACH PMT NO. - 80134643	139.75
SPOKANE COUNTY CLERK	MISC SERVICES/CHARGES CHECK NO. - 00606539	25.00
TOTAL FOR 0700 - PUBLIC DEFENDER		2,005.77

0750 - COMMUNITY/ECONOMIC DEV SVC

NEW MARKETS TAX CREDIT COALITION INC	OTH DUES/SUBSCRIPTNS/MEMBERSHP ACH PMT NO. - 80134685	750.00
WEST PLAINS AIRPORT AREA PUBLIC DEVELOPMENT AUTHORITY	CONTRACTUAL SERVICES ACH PMT NO. - 80134569	159,758.05
HONORABLE MAYOR AND COUNCIL MEMBERS		10/28/24 PAGE 7

PROCESSING OF VOUCHERS RESULTS IN CLAIMS AS FOLLOWS:

TOTAL FOR 0750 - COMMUNITY/ECONOMIC DEV SVC	160,508.05
---	------------

1100 - STREET FUND

AVISTA UTILITIES	UTILITY LIGHT/POWER SERVICE ACH PMT NO. - 80134514	27,497.44
CENTURYLINK	TELEPHONE CHECK NO. - 00606525	234.60
ENNIS FLINT INC	MISC SERVICES/CHARGES ACH PMT NO. - 80134526	42,150.30
ERGON ASPHALT & EMULSIONS INC	REPAIR & MAINTENANCE SUPPLIES ACH PMT NO. - 80134527	3,608.31
FASTENAL CO	OPERATING SUPPLIES	

	ACH PMT NO. - 80134529	1,596.56
FIREPOWER INC	ALARM/SECURITY SERVICES	
	ACH PMT NO. - 80134531	245.26
SHAMROCK MANUFACTURING INC	REPAIR & MAINTENANCE SUPPLIES	
	ACH PMT NO. - 80134691	115,087.98
SPECIALTY MOBILE MIX INC	REPAIR & MAINTENANCE SUPPLIES	
	ACH PMT NO. - 80134557	632.20
VERIZON WIRELESS	CELL PHONE	
	ACH PMT NO. - 80134564	299.53
VERIZON WIRELESS	IT/DATA SERVICES	
	ACH PMT NO. - 80134564	519.14
WESLEN CONSTRUCTION INC	CONTRACTUAL SERVICES	
	CHECK NO. - 00606622	63,012.39
WHITWORTH WATER DISTRICT NO 2	PUBLIC UTILITY SERVICE	
	CHECK NO. - 00606546	129.40
		-----
TOTAL FOR 1100 - STREET FUND		255,013.11

1200 - CODE ENFORCEMENT FUND

CLARK'S CONTAINERS LLC	OPERATING RENTALS/LEASES	
	ACH PMT NO. - 80134518	116.36
LEGEND INVESTMENTS CORP DBA NATIONAL BARRICADE CO OF	OPERATING SUPPLIES	
	ACH PMT NO. - 80134540	374.96
NORTH COUNTRY SERVICES LLC	CONTRACTUAL SERVICES	
	ACH PMT NO. - 80134686	1,290.52
NORTHWEST INDUSTRIAL SERVICES DBA AMERICAN ON SITE SERVICES	OPERATING RENTALS/LEASES	
	CREDIT CARD PMT NO. - 70000813	159.63

HONORABLE MAYOR  
AND COUNCIL MEMBERS

10/28/24  
PAGE 8

PROCESSING OF VOUCHERS RESULTS IN CLAIMS AS FOLLOWS:

SHERWIN WILLIAMS CO	OPERATING SUPPLIES	
	ACH PMT NO. - 80134555	601.35
VERIZON WIRELESS	CELL PHONE	
	ACH PMT NO. - 80134564	748.83
		-----
TOTAL FOR 1200 - CODE ENFORCEMENT FUND		3,291.65

1300 - LIBRARY FUND

US BANK	BANK FEES	
TREASURY MANAGEMENT SERVICES	CHECK NO. - 00606636	237.28
US BANK	EARNINGS CREDIT	
TREASURY MANAGEMENT SERVICES	CHECK NO. - 00606636	12.75-
		-----
TOTAL FOR 1300 - LIBRARY FUND		224.53

1360 - MISCELLANEOUS GRANTS FUND

DEPT OF ARCHAEOLOGY & HISTORIC PRESERVATION	DEPT OF INTERIOR/ARCHEOL CHECK NO. - 00606526	17,530.22
DEPT OF ARCHAEOLOGY & HISTORIC PRESERVATION	GRANT CASH PASS THRU ACCOUNT CHECK NO. - 00606526	17,530.22-
TOTAL FOR 1360 - MISCELLANEOUS GRANTS FUND		0.00

1380 - TRAFFIC CALMING MEASURES

BACON CONCRETE INC	CONSTRUCTION OF FIXED ASSETS ACH PMT NO. - 80134603	362,379.43
CPM DEVELOPMENT CORP DBA INLAND ASPHALT COMPANY	CONSTRUCTION OF FIXED ASSETS ACH PMT NO. - 80134534	417.47
LEGEND INVESTMENTS CORP DBA NATIONAL BARRICADE CO OF	MACHINERY/EQUIPMENT ACH PMT NO. - 80134540	73,019.10
TOTAL FOR 1380 - TRAFFIC CALMING MEASURES		435,816.00

1400 - PARKS AND RECREATION FUND

ACRANET CBS BRANCH/DIV OF CBS REPORTING INC	BACKGROUND CHECKS ACH PMT NO. - 80134509	552.00
ADRIANO M EVA	PER DIEM ACH PMT NO. - 80134581	98.16
US BANK TREASURY MANAGEMENT SERVICES	BANK FEES CHECK NO. - 00606636	350.06

HONORABLE MAYOR  
AND COUNCIL MEMBERS

10/28/24  
PAGE 9

PROCESSING OF VOUCHERS RESULTS IN CLAIMS AS FOLLOWS:

TOTAL FOR 1400 - PARKS AND RECREATION FUND		1,000.22
--	--	----------

1425 - AMERICAN RESCUE PLAN

HIP OF SPOKANE COUNTY DBA COMMUNITY MINDED ENTERPRISES	CONTRACTUAL SERVICES CHECK NO. - 00606632	164,471.21
INNOVIA FOUNDATION	CONTRACTUAL SERVICES ACH PMT NO. - 80134681	138,993.61
VOLT MANAGEMENT CORP DBA VOLT WORKFORCE SOLUTIONS	CONTRACTUAL SERVICES ACH PMT NO. - 80134698	19,864.80
TOTAL FOR 1425 - AMERICAN RESCUE PLAN		323,329.62

1460 - PARKING METER REVENUE FUND

COPIERS NORTHWEST INC	OPERATING RENTALS/LEASES ACH PMT NO. - 80134524	159.87
PEROVICH PARTNERS INC dba SPEEDPRO IMAGING	OPERATING SUPPLIES CREDIT CARD PMT NO. - 70000821	371.92

US BANK	BANK FEES	
TREASURY MANAGEMENT SERVICES	CHECK NO. - 00606636	554.05
VERIZON WIRELESS	CELL PHONE	
	ACH PMT NO. - 80134564	492.08
VERIZON WIRELESS	IT/DATA SERVICES	
	ACH PMT NO. - 80134564	120.03
WA STATE DEPT OF LICENSING	LEGAL SERVICES	
ATTN: RECORD REQUEST UNIT	CHECK NO. - 00606543	4.64
TOTAL FOR 1460 - PARKING METER REVENUE FUND		1,702.59
-----		
1560 - FORFEITURES & CONTRIBUTION FND		
-----		
NORTH COUNTRY SERVICES LLC	LEGAL SERVICES	
	ACH PMT NO. - 80134591	902.48
SPOKANE COUNTY CLERK	LEGAL SERVICES	
	CHECK NO. - 00606538	246.00
WA STATE DEPT OF LICENSING	MISC SERVICES/CHARGES	
SPOKANE COUNTY COURTHOUSE	CHECK NO. - 00606620	210.00
TOTAL FOR 1560 - FORFEITURES & CONTRIBUTION FND		1,358.48
-----		
1620 - PUBLIC SAFETY & JUDICIAL GRANT		
-----		
HONORABLE MAYOR		10/28/24
AND COUNCIL MEMBERS		PAGE 10
PROCESSING OF VOUCHERS RESULTS IN CLAIMS AS FOLLOWS:		
JESSICA A MCGREGOR	PROFESSIONAL SERVICES	
	ACH PMT NO. - 80134659	2,509.34
TOTAL FOR 1620 - PUBLIC SAFETY & JUDICIAL GRANT		2,509.34
-----		
1640 - COMMUNICATIONS BLDG M&O FUND		
-----		
CONTROL SOLUTIONS NW INC	BUILDING REPAIRS/MAINTENANCE	
	ACH PMT NO. - 80134523	17,222.00
TOTAL FOR 1640 - COMMUNICATIONS BLDG M&O FUND		17,222.00
-----		
1695 - CDBG REVOLVING LOAN FUND		
-----		
FIRST IMPRESSIONS CREATIVE	IF REPROGRAPHICS	
PRINTING INC	CHECK NO. - 00606601	115.54
TOTAL FOR 1695 - CDBG REVOLVING LOAN FUND		115.54
-----		
1910 - CRIMINAL JUSTICE ASSISTANCE FD		
-----		
DS SERVICES OF AMERICA INC	OFFICE SUPPLIES	
DBA CRYSTAL SPRINGS	CHECK NO. - 00606600	49.46
NONICA ANDREW DBA MARSHALLESE	INTERPRETER COSTS	



GALLS LLC	CLOTHING CREDIT CARD PMT NO. - 70000815	669.92
GALLS LLC	CLOTHING ALTERATIONS & REPAIRS CREDIT CARD PMT NO. - 70000815	20.84
GLOBAL FEDERAL CREDIT UNION PO BOX 196020	PERMIT REFUNDS PAYABLE CHECK NO. - 00606607	38.00
GORDON TRUCK CENTERS INC DBA PACIFIC TRUCK CENTERS	VEHICLE REPAIR & MAINT SUPPLY CREDIT CARD PMT NO. - 70000816	1,517.72
JOHN F GOODMAN	PER DIEM ACH PMT NO. - 80134582	88.50
KENWORTH SALES COMPANY	VEHICLE REPAIR & MAINT SUPPLY ACH PMT NO. - 80134535	64.64
KYOCERA DOCUMENT SOLUTIONS AMERICA INC	EQUIPMENT REPAIRS/MAINTENANCE ACH PMT NO. - 80134630	1,089.60
LIFE ASSIST INC	OPERATING SUPPLIES ACH PMT NO. - 80134633	437.74

HONORABLE MAYOR  
AND COUNCIL MEMBERS

10/28/24  
PAGE 12

PROCESSING OF VOUCHERS RESULTS IN CLAIMS AS FOLLOWS:

NORCO INC	OPERATING SUPPLIES CREDIT CARD PMT NO. - 70000817	887.81
NORCO INC	SAFETY SUPPLIES CREDIT CARD PMT NO. - 70000828	242.00
NORTHWEST RIVER SUPPLIES INC	MINOR EQUIPMENT ACH PMT NO. - 80134636	1,212.54
OCCUPATIONAL HEALTH SOLUTIONS INC	MEDICAL SERVICES ACH PMT NO. - 80134637	168.00
POINTE PEST CONTROL	BUILDING REPAIRS/MAINTENANCE CHECK NO. - 00606535	130.80
POMP'S TIRE SERVICE INC	VEHICLE REPAIR & MAINT SUPPLY ACH PMT NO. - 80134642	9,575.81
POMP'S TIRE SERVICE INC	VEHICLE REPAIRS/MAINT ACH PMT NO. - 80134642	1,605.71
SAFETY KLEEN CORPORATION	HAZARDOUS WASTE DISPOSAL CHECK NO. - 00606537	1,660.70
SIGNS FOR SUCCESS INC	VEHICLE REPAIR & MAINT SUPPLY CREDIT CARD PMT NO. - 70000819	859.67
SIGNS FOR SUCCESS INC	VEHICLES CREDIT CARD PMT NO. - 70000819	735.26
SITEONE LANDSCAPE SUPPLY LLC	REPAIR & MAINTENANCE SUPPLIES CREDIT CARD PMT NO. - 70000820	24.68
SPOKANE FIRE FIGHTERS BENEFIT TRUST	VEBA POST EMPLOYMENT ACH PMT NO. - 80134597	16,500.00
SPOKANE RESTAURANT EQUIPMENT	MINOR EQUIPMENT ACH PMT NO. - 80134649	5,469.42

SWANSON'S REFRIGERATION & RESTAURANT REPAIR	EQUIPMENT REPAIRS/MAINTENANCE CHECK NO. - 00606615	456.17
SWANSON'S REFRIGERATION & RESTAURANT REPAIR	REPAIR & MAINTENANCE SUPPLIES CHECK NO. - 00606615	519.48
US BANK TREASURY MANAGEMENT SERVICES	BANK FEES CHECK NO. - 00606636	190.22
VERIZON WIRELESS	IT/DATA SERVICES ACH PMT NO. - 80134653	360.09
WA STATE DEPT OF REVENUE	EQUIPMENT REPAIRS/MAINTENANCE -	98.07
WESTERN STATES EQUIPMENT CO	VEHICLE REPAIR & MAINT SUPPLY CREDIT CARD PMT NO. - 70000830	593.12

TOTAL FOR 1970 - FIRE/EMS FUND	-----	63,287.48
--------------------------------	-------	-----------

HONORABLE MAYOR  
AND COUNCIL MEMBERS

10/28/24  
PAGE 13

PROCESSING OF VOUCHERS RESULTS IN CLAIMS AS FOLLOWS:

3200 - ARTERIAL STREET FUND

CPM DEVELOPMENT CORP DBA INLAND ASPHALT COMPANY	CONSTRUCTION OF FIXED ASSETS ACH PMT NO. - 80134534	268,421.11
HALME CONSTRUCTION INC	CONSTRUCTION OF FIXED ASSETS ACH PMT NO. - 80134679	62,561.20
KPFF CONSULTING ENGINEERS	CONSTRUCTION OF FIXED ASSETS ACH PMT NO. - 80134629	19,589.95
PARAMETRIX INC	CONSTRUCTION OF FIXED ASSETS ACH PMT NO. - 80134639	7,973.90

TOTAL FOR 3200 - ARTERIAL STREET FUND	-----	358,546.16
---------------------------------------	-------	------------

4100 - WATER DIVISION

ACTION MATERIALS	REPAIR & MAINTENANCE SUPPLIES ACH PMT NO. - 80134510	6,780.91
ANATEK LABS INC	CONTRACTUAL SERVICES CREDIT CARD PMT NO. - 70000822	40.00
BETHANY NEVAREZ 5612 N PINEGROVE DR	REFUNDS CHECK NO. - 00606602	173.67
CDW GOVERNMENT INC	SMART PHONES, IPAD, TABLETS ACH PMT NO. - 80134606	41.30
COLUMBIA ELECTRIC SUPPLY/DIV CONSOLIDATED ELECTRICAL	REPAIR & MAINTENANCE SUPPLIES ACH PMT NO. - 80134520	3,349.03
COPIERS NORTHWEST INC	OPERATING RENTALS/LEASES ACH PMT NO. - 80134608	165.29
DOUGLAS GREENLUND	OTHER TRANSPORTATION EXPENSES ACH PMT NO. - 80134583	507.19
DOUGLAS GREENLUND	PER DIEM ACH PMT NO. - 80134583	76.00



FASTENAL CO	REPAIR & MAINTENANCE SUPPLIES ACH PMT NO. - 80134619	2,219.07
FEDERAL EXPRESS CORP/DBA FEDEX	POSTAGE ACH PMT NO. - 80134620	65.36
FISHER CONSTRUCTION GROUP INC	BUILDING REPAIRS/MAINTENANCE ACH PMT NO. - 80134677	1,226.25
GRAINGER INC	MINOR EQUIPMENT ACH PMT NO. - 80134623	1,921.71
GRAINGER INC	REPAIR & MAINTENANCE SUPPLIES ACH PMT NO. - 80134623	2,577.61

HONORABLE MAYOR  
AND COUNCIL MEMBERS

10/28/24  
PAGE 14

PROCESSING OF VOUCHERS RESULTS IN CLAIMS AS FOLLOWS:

KENWORTH SALES COMPANY	MACHINERY/EQUIPMENT ACH PMT NO. - 80134535	220,612.55
MAX J KUNEY COMPANY	CONSTRUCTION OF FIXED ASSETS ACH PMT NO. - 80134590	215,820.00
NORFOLK IRON & METAL CO DBA CDA METALS	REPAIR & MAINTENANCE SUPPLIES CHECK NO. - 00606598	3,326.40
RAY TURF FARMS INC	REPAIR & MAINTENANCE SUPPLIES ACH PMT NO. - 80134551	176.42
SHI CORP	SOFTWARE (NONCAPITALIZED) ACH PMT NO. - 80134556	53.04
SITEONE LANDSCAPE SUPPLY LLC	REPAIR & MAINTENANCE SUPPLIES CREDIT CARD PMT NO. - 70000820	39.02
SPOKANE CITY TREASURER OR WASH STATE DEPT OF REVENUE	WA DEPT OF REVENUE CHECK NO. - 00606553	319,330.87
TOTAL FOR 4100 - WATER DIVISION		778,501.69

4250 - INTEGRATED CAPITAL MANAGEMENT

CARAHSOFT TECHNOLOGY CORP	SOFTWARE (NONCAPITALIZED) ACH PMT NO. - 80134669	798.67
GROUNDWATER SOLUTIONS INC dba GSI WATER SOLUTIONS INC	CONSTRUCTION OF FIXED ASSETS ACH PMT NO. - 80134624	60,037.78
LANDMARK STRUCTURES I LP	CONSTRUCTION OF FIXED ASSETS ACH PMT NO. - 80134588	3,002.89
LSB CONSULTING ENGINEERS PLLC	CONSTRUCTION OF FIXED ASSETS ACH PMT NO. - 80134537	187.50
MERCHANTS NATIONAL BONDING INC c/o PETER FASCIA CPA	CONSTRUCTION OF FIXED ASSETS CHECK NO. - 00606555	190,706.62
OAC SERVICES INC	CONSTRUCTION OF FIXED ASSETS ACH PMT NO. - 80134545	8,352.50
PARAMETRIX INC	CONSTRUCTION OF FIXED ASSETS ACH PMT NO. - 80134548	46,838.75

SPOKANE CITY TREASURER OR WASH STATE DEPT OF REVENUE	WA DEPT OF REVENUE CHECK NO. - 00606553	64,616.03
---	--	-----------

TOTAL FOR 4250 - INTEGRATED CAPITAL MANAGEMENT		----- 374,540.74
--	--	---------------------

4310 - SEWER MAINTENANCE DIVISION

ACTION MATERIALS	REPAIR & MAINTENANCE SUPPLIES ACH PMT NO. - 80134510	697.57
------------------	---	--------

HONORABLE MAYOR AND COUNCIL MEMBERS		10/28/24 PAGE 15
--	--	---------------------

PROCESSING OF VOUCHERS RESULTS IN CLAIMS AS FOLLOWS:

ALSCO DIVISION OF ALSCO INC	LAUNDRY/JANITORIAL SERVICES ACH PMT NO. - 80134601	769.21
-----------------------------	---	--------

COPIERS NORTHWEST INC	OPERATING RENTALS/LEASES ACH PMT NO. - 80134608	863.33
-----------------------	--	--------

D & L SUPPLY CO INC	REPAIR & MAINTENANCE SUPPLIES ACH PMT NO. - 80134613	25,887.50
---------------------	---	-----------

SPOKANE CITY TREASURER OR WASH STATE DEPT OF REVENUE	WA DEPT OF REVENUE CHECK NO. - 00606553	73,137.17
---	--	-----------

SPOKANE HOUSE OF HOSE INC	REPAIR & MAINTENANCE SUPPLIES CREDIT CARD PMT NO. - 70000829	536.99
---------------------------	---	--------

T W CLARK CONSTRUCTION LLC	CONSTRUCTION OF FIXED ASSETS ACH PMT NO. - 80134580	59,171.74
----------------------------	--	-----------

THE DRAIN SPECIALISTS	CONSTRUCTION OF FIXED ASSETS ACH PMT NO. - 80134616	931.95
-----------------------	--	--------

TOTAL FOR 4310 - SEWER MAINTENANCE DIVISION		----- 161,995.46
---	--	---------------------

4320 - RIVERSIDE PARK RECLAMATION FAC

AM HARDWARE CO	REPAIR & MAINTENANCE SUPPLIES ACH PMT NO. - 80134664	550.45
----------------	---	--------

BIG JOHN MFG CO INC	MACHINERY/EQUIPMENT CHECK NO. - 00606596	11,930.00
---------------------	---	-----------

CASCADE COLUMBIA DISTRIBUTION CO/DIV OF NEWCO INC	CHEMICAL/LAB SUPPLIES ACH PMT NO. - 80134605	1,744.00
--	---	----------

CENTURYLINK	TELEPHONE CHECK NO. - 00606597	8,192.28
-------------	-----------------------------------	----------

CHRIS PYLES	MINOR SAFETY EQUIPMENT CHECK NO. - 00606610	180.00
-------------	--	--------

EUROFINS ENVIRONMENT TESTING NORTHWEST LLC	TESTING SERVICES ACH PMT NO. - 80134618	150.00
---	--	--------

FEDERAL EXPRESS CORP/DBA FEDEX	POSTAGE ACH PMT NO. - 80134620	95.02
--------------------------------	-----------------------------------	-------

FISHER SCIENTIFIC	OPERATING SUPPLIES ACH PMT NO. - 80134621	3,363.58
-------------------	--	----------

HASA INC	CHEMICAL/LAB SUPPLIES ACH PMT NO. - 80134626	15,682.61
JONI MEYER	PER DIEM ACH PMT NO. - 80134584	163.50
OCCUPATIONAL HEALTH SOLUTIONS INC	SAFETY SUPPLIES ACH PMT NO. - 80134637	500.00

HONORABLE MAYOR  
AND COUNCIL MEMBERS

10/28/24  
PAGE 16

PROCESSING OF VOUCHERS RESULTS IN CLAIMS AS FOLLOWS:

PATRICK B WISE	OTHER TRANSPORTATION EXPENSES CHECK NO. - 00606554	229.81
POINTE PEST CONTROL	CONTRACTUAL SERVICES CHECK NO. - 00606551	1,466.05
SPOKANE CITY TREASURER OR WASH STATE DEPT OF REVENUE	WA DEPT OF REVENUE CHECK NO. - 00606553	76,765.71
VERIZON WIRELESS	TELEPHONE ACH PMT NO. - 80134653	805.05
WA STATE DEPT OF REVENUE	MACHINERY/EQUIPMENT -	1,073.70
TOTAL FOR 4320 - RIVERSIDE PARK RECLAMATION FAC		122,891.76

4330 - STORMWATER

ALSCO DIVISION OF ALSCO INC	LAUNDRY/JANITORIAL SERVICES ACH PMT NO. - 80134601	769.22
ARROW CONCRETE & ASPHALT SPECIALTIES LLC	PAVING REPAIRS/MAINTENANCE ACH PMT NO. - 80134576	27,113.75
AVISTA UTILITIES	UTILITY LIGHT/POWER SERVICE ACH PMT NO. - 80134602	72.37
CENTURYLINK	TELEPHONE CHECK NO. - 00606597	2,177.70
TOTAL FOR 4330 - STORMWATER		30,133.04

4480 - SOLID WASTE FUND

SPOKANE CITY TREASURER OR WASH STATE DEPT OF REVENUE	DEPOSIT-REFUSE COLLECTION TAX CHECK NO. - 00606553	43.73
SPOKANE CITY TREASURER OR WASH STATE DEPT OF REVENUE	DEPOSIT-SALES TAX CHECK NO. - 00606553	2,168.70
TOTAL FOR 4480 - SOLID WASTE FUND		2,212.43

4490 - SOLID WASTE DISPOSAL

CDW GOVERNMENT INC	MINOR EQUIPMENT ACH PMT NO. - 80134670	495.84
CINTAS CORPORATION	LAUNDRY/JANITORIAL SERVICES	

	CREDIT CARD PMT NO. - 70000823	12,112.23
COPIERS NORTHWEST INC	OPERATING RENTALS/LEASES	
	ACH PMT NO. - 80134608	934.08

HONORABLE MAYOR  
AND COUNCIL MEMBERS

10/28/24  
PAGE 17

PROCESSING OF VOUCHERS RESULTS IN CLAIMS AS FOLLOWS:

HYDRAULICS PLUS INC	EQUIPMENT REPAIRS/MAINTENANCE CREDIT CARD PMT NO. - 70000826	2,378.76
NALCO CO	CHEMICAL/LAB SUPPLIES ACH PMT NO. - 80134635	4,045.72
OIL RE-REFINING CO INC	HAZARDOUS WASTE DISPOSAL ACH PMT NO. - 80134638	206.25
PETE LIEN & SONS INC	CHEMICAL/LAB SUPPLIES ACH PMT NO. - 80134641	11,249.44
SPOKANE CITY TREASURER OR WASH STATE DEPT OF REVENUE	WA DEPT OF REVENUE CHECK NO. - 00606553	28,588.83
SPOKANE REGIONAL HEALTH DIST	PERMITS/OTHER FEES CHECK NO. - 00606612	22,414.52
SPRING ENVIRONMENTAL INC	REGISTRATION/SCHOOLING ACH PMT NO. - 80134650	2,300.00
THE BABCOCK & WILCOX COMPANY	EQUIPMENT REPAIRS/MAINTENANCE ACH PMT NO. - 80134656	404.61
US BANK TREASURY MANAGEMENT SERVICES	BANK FEES CHECK NO. - 00606636	268.09
VERIZON WIRELESS	CELL PHONE ACH PMT NO. - 80134653	506.10
WA STATE DEPT OF ECOLOGY	PERMITS/OTHER FEES CHECK NO. - 00606617	2,269.00
WM RECYCLE AMERICA LLC	CONTRACTUAL SERVICES CHECK NO. - 00606623	128.77
		-----
TOTAL FOR 4490 - SOLID WASTE DISPOSAL		88,302.24

4500 - SOLID WASTE COLLECTION

ACRANET CBS BRANCH/DIV OF CBS REPORTING INC	BACKGROUND CHECKS ACH PMT NO. - 80134509	20.00
HOTSY OF SPOKANE LLC	EQUIPMENT REPAIRS/MAINTENANCE ACH PMT NO. - 80134628	4,843.93
PERFORMANCE SYSTEMS INTEGRATION LLC	REPAIR & MAINTENANCE SUPPLIES ACH PMT NO. - 80134549	192.83
SPOKANE CITY TREASURER OR WASH STATE DEPT OF REVENUE	WA DEPT OF REVENUE CHECK NO. - 00606553	109,984.88
		-----
TOTAL FOR 4500 - SOLID WASTE COLLECTION		115,041.64

4530 - SOLID WASTE LANDFILLS

PROCESSING OF VOUCHERS RESULTS IN CLAIMS AS FOLLOWS:

CINTAS CORPORATION	LAUNDRY/JANITORIAL SERVICES CREDIT CARD PMT NO. - 70000823	154.80
SPOKANE REGIONAL HEALTH DIST	PERMITS/OTHER FEES CHECK NO. - 00606612	0.36
VERIZON WIRELESS	CELL PHONE ACH PMT NO. - 80134653	82.80
TOTAL FOR 4530 - SOLID WASTE LANDFILLS		237.96

4600 - GOLF FUND

ACRANET CBS BRANCH/DIV OF CBS REPORTING INC	BACKGROUND CHECKS ACH PMT NO. - 80134509	24.00
US BANK TREASURY MANAGEMENT SERVICES	BANK FEES CHECK NO. - 00606636	529.10
TOTAL FOR 4600 - GOLF FUND		553.10

4700 - DEVELOPMENT SVCS CENTER

CANENG STRUCTURAL CONSULTING 1108 W FAIRVIEW AVE	PERMIT REFUNDS PAYABLE CHECK NO. - 00606527	25.00
COPIERS NORTHWEST INC	OPERATING RENTALS/LEASES ACH PMT NO. - 80134524	357.14
DALTON KUHN	OTH DUES/SUBSCRIPTNS/MEMBERSHP ACH PMT NO. - 80134573	116.00
ILLIA & SVETLANA BILOUS 8520 N AUSTIN RD	PERMIT REFUNDS PAYABLE CHECK NO. - 00606529	100.00
PLUMB ZEBRA & TURD NERDS 1622 N WILLOW RD	PERMIT REFUNDS PAYABLE CHECK NO. - 00606530	44.00
RIGHT NOW HEATING AND COOLING 212 EVANS ST	PERMIT REFUNDS PAYABLE CHECK NO. - 00606531	45.00
US BANK TREASURY MANAGEMENT SERVICES	BANK FEES CHECK NO. - 00606636	189.49
TOTAL FOR 4700 - DEVELOPMENT SVCS CENTER		876.63

5100 - FLEET SERVICES FUND

AMERICAN RADIATOR INC	EQUIPMENT REPAIRS/MAINTENANCE ACH PMT NO. - 80134512	10,210.96
CINTAS CORPORATION	LAUNDRY/JANITORIAL SERVICES CREDIT CARD PMT NO. - 70000814	1,310.11

PROCESSING OF VOUCHERS RESULTS IN CLAIMS AS FOLLOWS:

COLEMAN OIL COMPANY LLC	MOTOR FUEL-OUTSIDE VENDOR ACH PMT NO. - 80134671	129,233.32
CONNELL OIL INC DBA CO-ENERGY	LUBRICANTS ACH PMT NO. - 80134672	2,404.29
COPIERS NORTHWEST INC	LAUNDRY/JANITORIAL SERVICES ACH PMT NO. - 80134524	643.94
CUMMINS INC DBA CUMMINS SALES & SERVICE	EQUIPMENT REPAIRS/MAINTENANCE ACH PMT NO. - 80134611	244.86
EMERALD SERVICES INC	HAZARDOUS WASTE DISPOSAL CHECK NO. - 00606633	50.40
EVERGREEN STATE TOWING LLC DBA SPOKANE VALLEY TOWING	TOWING EXPENSE CREDIT CARD PMT NO. - 70000832	1,105.26
GWP HOLDINGS LLC DBA DOBBS PETERBILT	EQUIPMENT REPAIRS/MAINTENANCE ACH PMT NO. - 80134675	34,068.49
NORTH DIVISION MUFFLER CLINIC	EQUIPMENT REPAIRS/MAINTENANCE ACH PMT NO. - 80134687	168.95
POMP'S TIRE SERVICE INC	EQUIPMENT REPAIRS/MAINTENANCE ACH PMT NO. - 80134689	8,020.41
POMP'S TIRE SERVICE INC	VEHICLE REPAIR & MAINT SUPPLY ACH PMT NO. - 80134689	19,664.62
SAFETY KLEEN CORPORATION	HAZARDOUS WASTE DISPOSAL CHECK NO. - 00606635	254.50
WASHINGTON EQUIPMENT MANUFACTURING CO INC	BUILDING REPAIRS/MAINTENANCE ACH PMT NO. - 80134567	3,052.00
TOTAL FOR 5100 - FLEET SERVICES FUND		210,432.11

5200 - PUBLIC WORKS AND UTILITIES

CANON SOLUTIONS AMERICA INC	OPERATING SUPPLIES ACH PMT NO. - 80134668	4,600.00
COPIERS NORTHWEST INC	OPERATING RENTALS/LEASES ACH PMT NO. - 80134608	89.77
CORE92 INC	SOFTWARE MAINTENANCE CREDIT CARD PMT NO. - 70000824	288.00
KERSHAW'S INC	OFFICE FURNITURE (NON CAPITAL) CREDIT CARD PMT NO. - 70000827	775.67
POWERCOM.INC	CONTRACTUAL SERVICES ACH PMT NO. - 80134550	6,814.69
SPOKANE CITY TREASURER OR WASH STATE DEPT OF REVENUE	WA DEPT OF REVENUE CHECK NO. - 00606553	1,602.60

HONORABLE MAYOR  
AND COUNCIL MEMBERS

10/28/24  
PAGE 20

PROCESSING OF VOUCHERS RESULTS IN CLAIMS AS FOLLOWS:

SPOKANE COUNTY TREASURER                      SPOKANE COUNTY

	ACH PMT NO. - 80134648	2,452.79
US BANK	BANK FEES	
TREASURY MANAGEMENT SERVICES	CHECK NO. - 00606636	20,681.02
WA STATE DEPT OF REVENUE	SOFTWARE MAINTENANCE	
	-	25.92
TOTAL FOR 5200 - PUBLIC WORKS AND UTILITIES		37,330.46

5300 - IT FUND

CAMTEK INC	MINOR EQUIPMENT	
	ACH PMT NO. - 80134516	188.01
CANON SOLUTIONS AMERICA INC	OPERATING SUPPLIES	
	ACH PMT NO. - 80134668	517.55
CENTURYLINK	TELEPHONE	
	CHECK NO. - 00606525	5,684.84
COMCAST	IT/DATA SERVICES	
	CHECK NO. - 00606599	355.76
COMPUNET INC	OPERATING SUPPLIES	
LB 410802	ACH PMT NO. - 80134521	1,448.94
SHI CORP	SOFTWARE MAINTENANCE	
	ACH PMT NO. - 80134646	312.48
T-MOBILE	IT/DATA SERVICES	
	CHECK NO. - 00606540	29.75
TOTAL FOR 5300 - IT FUND		8,537.33

5310 - IT CAPITAL REPLACEMENT FUND

DELL MARKETING LP	COMPUTERS	
%DELL USA LP	ACH PMT NO. - 80134525	2,971.42
TOTAL FOR 5310 - IT CAPITAL REPLACEMENT FUND		2,971.42

5750 - OFFICE OF PERFORMANCE MGMT

INFINITE INNOVATIONS LLC	CONTRACTUAL SERVICES	
	ACH PMT NO. - 80134532	8,051.25
TOTAL FOR 5750 - OFFICE OF PERFORMANCE MGMT		8,051.25

5800 - RISK MANAGEMENT FUND

HONORABLE MAYOR		10/28/24
AND COUNCIL MEMBERS		PAGE 21
PROCESSING OF VOUCHERS RESULTS IN CLAIMS AS FOLLOWS:		
OCCUPATIONAL HEALTH SOLUTIONS	PROFESSIONAL SERVICES	
INC	ACH PMT NO. - 80134546	2,011.00
US BANK	BANK FEES	
TREASURY MANAGEMENT SERVICES	CHECK NO. - 00606636	232.99

US BANK	EARNINGS CREDIT	
TREASURY MANAGEMENT SERVICES	CHECK NO. - 00606636	232.99-
US BANK OR CITY TREASURER	INSURANCE CLAIMS	
LIABILITY CLAIMS	ACH PMT NO. - 80134563	93,254.68
VICTOR J GIAMPIETRI II	CONTRACTUAL SERVICES	
DBA WA STATE FIRST AID	ACH PMT NO. - 80134654	600.00

-----

TOTAL FOR 5800 - RISK MANAGEMENT FUND		95,865.68
---------------------------------------	--	-----------

5810 - WORKERS' COMPENSATION FUND

SPOKANE ENVELOPE LLC	PRINTING/BINDING/REPRO	
DBA ALLIED ENVELOPE	ACH PMT NO. - 80134662	79.42

-----

TOTAL FOR 5810 - WORKERS' COMPENSATION FUND		79.42
---	--	-------

5820 - UNEMPLOYMENT COMPENSATION FUND

WA STATE EMPLOYMENT SECURITY	DEPOSIT LONG TERM CARE TAX	
WA CARES FUND	CHECK NO. - 00606557	236,286.61

WA STATE EMPLOYMENT SECURITY	DEPOSIT-PD FAMILY MEDICAL LEAV	
PAID FAMILY MEDICAL LEAVE	CHECK NO. - 00606556	436,475.25

-----

TOTAL FOR 5820 - UNEMPLOYMENT COMPENSATION FUND		672,761.86
---	--	------------

5830 - EMPLOYEES BENEFITS FUND

ALLIANT INSURANCE SERVICES INC	CONTRACTUAL SERVICES	
	ACH PMT NO. - 80134600	5,720.00

DELTA DENTAL OF WASHINGTON	INSURANCE CLAIMS	
	ACH PMT NO. - 80134674	34,864.57

HRA VEBA TRUST	DEPOSIT-HEALTH CARE ACCOUNT	
HRA VEBA TRUST CONTRIBUTIONS	ACH PMT NO. - 80134587	55,995.50

KAISER FOUNDATION HEALTH PLAN	INSURANCE ADMINISTRATION	
OF WASHINGTON	ACH PMT NO. - 80134683	78,822.52

KAISER FOUNDATION HEALTH PLAN	INSURANCE CLAIMS	
OF WASHINGTON	ACH PMT NO. - 80134683	130,124.92

KAISER FOUNDATION HEALTH PLAN	INSURANCE PREMIUMS	
OF WASHINGTON	ACH PMT NO. - 80134683	24,735.70

HONORABLE MAYOR	10/28/24
AND COUNCIL MEMBERS	PAGE 22

PROCESSING OF VOUCHERS RESULTS IN CLAIMS AS FOLLOWS:

PREMERA BLUE CROSS OR	INSURANCE ADMINISTRATION	
SPOKANE CITY TREASURER	ACH PMT NO. - 80134690	61,651.40

PREMERA BLUE CROSS OR	INSURANCE CLAIMS	
SPOKANE CITY TREASURER	ACH PMT NO. - 80134592	804,613.55

-----

TOTAL FOR 5830 - EMPLOYEES BENEFITS FUND		1,196,528.16
--	--	--------------



5900 - FACILITIES MANAGEMENT FUND OPS

A ACTIONTECH INC	BUILDING REPAIRS/MAINTENANCE CHECK NO. - 00606629	228.90
ABM JANITORIAL SERVICES SOUTH SOUTH CENTRAL INC dba	LAUNDRY/JANITORIAL SERVICES ACH PMT NO. - 80134599	11,718.37
AM HARDWARE CO	REPAIR & MAINTENANCE SUPPLIES ACH PMT NO. - 80134664	1,803.93
AMERICAN SPRINKLER REPAIR AND LANDSCAPE LLC	BUILDING REPAIRS/MAINTENANCE CHECK NO. - 00606630	1,793.05
AVISTA CORPORATION	UTILITY LIGHT/POWER SERVICE ACH PMT NO. - 80134665	35,699.84
AVISTA CORPORATION	UTILITY NATURAL GAS ACH PMT NO. - 80134665	472.51
BRYAN T HILL DBA TINYS SERVICE AND	REPAIR & MAINTENANCE SUPPLIES ACH PMT NO. - 80134694	218.00
CENTURYLINK	TELEPHONE CHECK NO. - 00606631	403.94
CONTROL SOLUTIONS NW INC	BUILDING REPAIRS/MAINTENANCE ACH PMT NO. - 80134523	81.75
FIREPOWER INC	BUILDING REPAIRS/MAINTENANCE ACH PMT NO. - 80134676	2,906.20
NW MUSEUM OF ARTS & CULTURE/ DIV OF EASTERN WA STATE	OPERATING RENTALS/LEASES ACH PMT NO. - 80134544	261.60
OTIS ELEVATOR COMPANY	BUILDING REPAIRS/MAINTENANCE ACH PMT NO. - 80134547	2,643.24
ROAR WORKS LLC	LANDSCAPE/GROUNDS MAINT ACH PMT NO. - 80134553	5,858.75
ROTO-ROOTER/DIV OF RAM PLUMBING INC	OTHER CONTRACTUAL SERVICES CHECK NO. - 00606536	464.07
STARPLEX CORP	ALARM/SECURITY SERVICES ACH PMT NO. - 80134560	30,705.67
VERIZON WIRELESS	CELL PHONE ACH PMT NO. - 80134564	721.91

HONORABLE MAYOR  
AND COUNCIL MEMBERS

10/28/24  
PAGE 23

PROCESSING OF VOUCHERS RESULTS IN CLAIMS AS FOLLOWS:

VERTICAL OPTIONS LLC	BUILDING REPAIRS/MAINTENANCE ACH PMT NO. - 80134696	1,220.80
----------------------	--	----------

TOTAL FOR 5900 - FACILITIES MANAGEMENT FUND OPS 97,202.53

5901 - ASSET MANAGEMENT FUND CAPITAL

GWP HOLDINGS LLC DBA DOBBS PETERBILT	MACHINERY/EQUIPMENT ACH PMT NO. - 80134675	220,213.71
---	---	------------

TOTAL FOR 5901 - ASSET MANAGEMENT FUND CAPITAL 220,213.71

5903 - PROPERTY ACQUISITION FIRE

L N CURTIS & SONS PERSONAL PROTECTIVE EQUIPMENT  
ACH PMT NO. - 80134612 693.53

TOBY'S BODY & FENDER INC VEHICLE REPAIRS/MAINT  
ACH PMT NO. - 80134652 10,111.70

TOTAL FOR 5903 - PROPERTY ACQUISITION FIRE 10,805.23

6200 - FIREFIGHTERS' PENSION FUND

ALLIANT INSURANCE SERVICES INC INSURANCE ADMINISTRATION  
ACH PMT NO. - 80134600 1,665.00

DELTA DENTAL OF WASHINGTON SERVICE REIMBURSEMENT  
ACH PMT NO. - 80134674 1,084.00

OMNICARE LLC SERVICE REIMBURSEMENT  
EVERGREEN PHARMACEUTICAL LLC CHECK NO. - 00606608 8.04

PREMERA BLUE CROSS OR INSURANCE ADMINISTRATION  
SPOKANE CITY TREASURER ACH PMT NO. - 80134690 6,845.28

PREMERA BLUE CROSS OR SERVICE REIMBURSEMENT  
SPOKANE CITY TREASURER ACH PMT NO. - 80134592 57,758.37

WELLTOWER PEGASUS TENNANT LLC SERVICE REIMBURSEMENT  
dba SOUTH HILL VILLAGE CHECK NO. - 00606621 6,281.00

WELLTOWER PEGASUS TENNANT LLC SERVICE REIMBURSEMENT  
dba SOUTH HILL VILLAGE CHECK NO. - 00606621 2,650.00

TOTAL FOR 6200 - FIREFIGHTERS' PENSION FUND 76,291.69

6255 - LAW ENFORCEMENT RECORDS MGMT

SPOKANE COUNTY TREASURER DEPOSIT-COUNTY  
ACH PMT NO. - 80134558 12,801.50

HONORABLE MAYOR 10/28/24  
AND COUNCIL MEMBERS PAGE 24

PROCESSING OF VOUCHERS RESULTS IN CLAIMS AS FOLLOWS:

WA STATE DEPT OF LICENSING DEPOSIT-POLICE GUN PERMITS  
CHECK NO. - 00606619 18,945.00

TOTAL FOR 6255 - LAW ENFORCEMENT RECORDS MGMT 31,746.50

6300 - POLICE PENSION

ALLIANT INSURANCE SERVICES INC INSURANCE ADMINISTRATION  
ACH PMT NO. - 80134600 1,665.00

DELTA DENTAL OF WASHINGTON SERVICE REIMBURSEMENT  
ACH PMT NO. - 80134674 2,097.00

GREGORY C HARSHMAN SERVICE REIMBURSEMENT  
ACH PMT NO. - 80134658 65.00

JAMES CULP	SERVICE REIMBURSEMENT ACH PMT NO. - 80134657	128.38
PREMERA BLUE CROSS OR SPOKANE CITY TREASURER	INSURANCE ADMINISTRATION ACH PMT NO. - 80134690	5,133.96
PREMERA BLUE CROSS OR SPOKANE CITY TREASURER	SERVICE REIMBURSEMENT ACH PMT NO. - 80134592	52,156.15
SULLIVAN VENTURES, LLC DBA SULLIVAN PARK ASSISTED LVG	SERVICE REIMBURSEMENT CHECK NO. - 00606614	5,685.00
SULLIVAN VENTURES, LLC DBA SULLIVAN PARK ASSISTED LVG	SERVICE REIMBURSEMENT CHECK NO. - 00606614	1,775.00
		-----
TOTAL FOR 6300 - POLICE PENSION		68,705.49
		-----
TOTAL CLAIMS		6,253,326.12



**Agenda Sheet for City Council:**

**Committee: Date:** N/A

**Committee Agenda type:**

**Date Rec'd**

10/30/2024

**Clerk's File #**

CPR 2024-0003

**Cross Ref #**

**Project #**

**Council Meeting Date:** 11/04/2024

**Submitting Dept**

ACCOUNTING & GRANTS

**Bid #**

**Contact Name/Phone**

MICHELLE 6032

**Requisition #**

**Contact E-Mail**

MMURRAY@SPOKANECITY.ORG

**Agenda Item Type**

Claim Item

**Council Sponsor(s)**

**Agenda Item Name**

5600-ACCOUNTING-PAYROLL THRU 10-26-2024

**Agenda Wording**

Report of the Mayor of pending payroll claims of previously approved obligations through: October 26, 2024.  
Payroll check #574812 through check #574933 \$9,516,549.61

**Summary (Background)**

N/A

Lease? NO Grant related? NO Public Works? NO

**Fiscal Impact**

Approved in Current Year Budget?

Total Cost \$

Current Year Cost \$

Subsequent Year(s) Cost \$

**Narrative**

**Amount**

**Budget Account**

Expense \$ 9,516,549.61

# Various

Select \$

#

Select \$

#

Select \$

#

\$

#

\$

#



## PAYROLL RECAP BY FUND

**PAY PERIOD ENDING OCTOBER 26, 2024**

FUND	FUND NAME	TOTAL
0100	GENERAL FUND	
0030	POLICE OMBUDSMAN	13,805.68
0230	CIVIL SERVICE	46,806.40
0260	CITY CLERK	24,848.82
0320	COUNCIL	59,313.60
0330	PUBLIC AFFAIRS / COMMUNICATIONS	32,036.52
0370	ENGINEERING SERVICES	202,104.43
0410	FINANCE	39,538.08
0450	CD/HS DIVISION	10,210.40
0470	HISTORIC PRESERVATION	8,231.20
0480	OFFICE OF CIVIL RIGHTS,EQUITY, & INCLUSION	4,887.20
0500	LEGAL	169,693.22
0520	MAYOR	36,201.20
0550	NEIGHBORHOOD SERVICES	14,044.00
05601	MUNICIPAL COURT	140,181.47
0570	OFFICE OF HEARING EXAMINER	6,935.20
0620	HUMAN RESOURCES	37,513.68
0650	PLANNING SERVICES	59,232.80
0680	POLICE	2,165,030.05
0690	PROBATION SERVICES	77,414.47
0700	PUBLIC DEFENDERS	99,278.89
0750	ECONOMIC DEVELOPMENT	9,857.60
0860	TREASURER	0.00
	TOTAL GENERAL FUND	3,257,164.91

FUND	FUND NAME	TOTAL
1100	STREET	300,722.18
1200	CODE ENFORCEMENT	71,318.69
1300	LIBRARY	294,232.10
1380	TRAFFIC CALMING MEASURES	3,317.60
1390	URBAN FORESTRY	2,719.20
1400	PARKS AND RECREATION	398,537.25
1425	AMERICAN RESCUE PLAN	2,127.50
1460	PARKING METER	37,353.32
1595	HOUSING SALES TAX	0.00
1620	PUBLIC SAFETY & JUDICIAL GRANT	17,231.04
1625	PUBLIC SAFETY PERSONNEL	201,830.66
1680	CD/HS	74,835.41
1910	CRIMINAL JUSTICE ASSISTANCES	2,460.00
1970	EMS FUND	1,923,247.93
4100	WATER	533,971.28
4250	INTEGRATED CAPITAL FUND	65,531.20
4300	SEWER	690,212.85
4480	REFUSE	665,181.60
4600	GOLF	70,108.02
4700	GENERAL SERVICES FUND	200,397.98
5100	FLEET SERVICE	135,264.03
5200	PUBLIC WORKS & UTILITY FUND	60,686.31
5300	MIS	185,233.21
5400	REPROGRAPHICS	5,866.68
5500	PURCHASING	28,724.00
5600	ACCOUNTING SERVICES	133,269.31
5700	MY SPOKANE	37,082.73
5750	PROJECT MANAGEMENT OFFICE	28,164.80
5800	RISK MANAGEMENT	13,519.78
5810	WORKER'S COMPENSATION	9,623.20
5830	SELF-FUNDED MEDICAL/DENTAL	9,476.09
5900	ASSET MANAGEMENT	46,812.34
6060	CITY RETIREMENT	10,326.41
	TOTAL	9,516,549.61

# MINUTES OF SPOKANE CITY COUNCIL

Monday, October 14, 2024

## BRIEFING SESSION

The Briefing Session of the Spokane City Council held on the above date was called to order at 3:33 p.m. in the Council Chambers in the Lower Level of the Municipal Building, 808 West Spokane Falls Boulevard, Spokane, Washington. A recording of the meeting can be found at the following link: <https://vimeo.com/spokanecitycouncil>.

### Roll Call

On roll call, Council President Wilkerson and Council Members Bingle (appearing virtually), Cathcart, Dillon, Klitzke, and Navarrete were present. Council Member Zappone arrived at 3:33 p.m.

Interim City Administrator Garrett Jones; Giacobbe Byrd, Director-City Council Office; City Council Policy Advisor Chris Wright; and City Clerk Terri Pfister were also present for the meeting.

### Candidate Interviews – Climate Resilience and Sustainability Board, Design Review Board, and Transportation Commission

The City Council interviewed Kevan Fagan, Kerry Brooks, and Hala Zahalqa, candidates for appointment to the Climate Resilience and Sustainability Board.

The City Council interviewed Carlos Fernando Diaz, candidate for appointment to the Design Review Board as Community Assembly representative.

The City Council interviewed Lauren Pangborn, candidate for appointment to the Transportation Commission as the Bicycle Advisory Board representative.

### Current Agenda Review

The City Council reviewed the October 14, 2024, Current Agenda for any updates. Assistant City Attorney Tim Szambelan provided an overview of Ordinance C36571 granting to BNSF Railway Company, a Delaware Corporation, a twenty-five-year franchise agreement. Jason Ruffing of Code Enforcement addressed Council inquiries regarding Ordinance C36576 streamlining rental registration requirements.

### Advance Agenda Review

The City Council received an overview of the October 21, 2024, Advance Agenda items.



First Reading Ordinance C36577 (Referred to the October 7, 2024, Public Safety and Community Health Committee from the September 23, 2024, Advance Agenda, during the September 16, 2024, 3:30 p.m. Briefing Session and returned for replacement on the October 21, 2024, Agenda) (Council Sponsors: Council Members Bingle and Cathcart)  
Council Member Zappone presented a motion, seconded by Council Member Klitzke, and debate followed. The following actions were taken:

**Motion** by Council Member Klitzke, seconded by Council Member Zappone, **to call** the question (stop debate); **carried 5-2.**

**Motion** by Council Member Zappone, seconded by Council Member Klitzke, **to defer** First Reading Ordinance C36577—relating to the prohibition of sitting and laying on public sidewalks, and amending Section 10.60.020 of the Spokane Municipal Code—until after the roundtables and Town Hall relating to homelessness have concluded; **carried 5-2.**

### **Action to Approve October 21, 2024, Advance Agenda**

Following staff reports and Council inquiry and discussion regarding the October 21, 2024, Advance Agenda items, the City Council took the following action (pursuant to Council Rule 2.1.B):

**Motion** by Council Member Klitzke, seconded by Council Member Zappone, **to approve** the October 21, 2024, Advance Agenda; **carried 5-2.**

### **Council Recess/Executive Session**

The City Council recessed at 4:27 p.m. and immediately reconvened into an Executive Session to discuss pending litigation for approximately 20 minutes. The Executive Session ended at 4:40 p.m., at which time the 3:30 p.m. Briefing Session also ended. City Attorney Michael Piccolo and Assistant City Attorney Lynden Smithson were present for the Executive Session. The City Council reconvened at 6:02 p.m. for the Legislative Session.

## **LEGISLATIVE SESSION**

### **Indigenous People's Day**

Council President Wilkerson acknowledged that today is Indigenous People's Day and noted that Toni Lodge with the Native Project will provide an update during next week's City Council meeting.

### **Land Acknowledgement**

Council President Wilkerson started the meeting off by reading the “Land Acknowledgement” (adopted by City Council on March 22, 2021, under Resolution 2021-0019) which appears on page 2 of the agenda.

**Pledge of Allegiance**

The Pledge of Allegiance was led by Council President Wilkerson.

**Roll Call**

On roll call, Council President Wilkerson and Council Members Bingle (appearing virtually), Cathcart, Dillon, Klitzke, Navarrete, and Zappone were present.

Giacobbe Byrd, Director-City Council Office; City Council Policy Advisor Chris Wright; and City Clerk Terri Pfister were also present for the meeting.

**Annual Mayoral Statement of the Conditions and Affairs of the City**

Mayor Lisa Brown presented the Annual Mayoral Statement of the Conditions and Affairs of the City. See attachment to these minutes.

There were no **Proclamations or Salutations**.

There were no **Reports from Community Organizations**.

**BOARD AND COMMISSION APPOINTMENTS**

**Appointments to Climate Resilience & Sustainability Board (CPR 2024-0030)**

**Upon 5-2 Voice Vote**, the City Council **approved (and thereby confirmed)** the appointments of Larry Luton, Happy Avery, Amanda Parrish, and Elyse Hochstadt to the Climate Resilience & Sustainability Board for two-year terms from October 14, 2024, to October 14, 2026.

**Upon 7-0 Voice Vote**, the City Council **approved (and thereby confirmed)** the appointment of Brian Henning (taken separately) to the Climate Resilience & Sustainability Board for a two-year term from October 14, 2024, to October 14, 2026.

**CONSENT AGENDA**

**(Clerical Note: Final Reading Ordinances C36586 through C36590 were considered prior to Council’s consideration of Consent Agenda items.)**

After public testimony and Council commentary, the following actions were taken:

**Upon 7-0 Voice Vote**, the City Council **approved** Staff Recommendations for the following items; **carried 7-0**:

Purchase from Kendall Chevrolet, LLC (Eugene, OR) of a 2024 Chevrolet Tahoe LS all-wheel drive diesel-powered vehicle for Spokane Treatment and Recovery Services as required by Fire Department Contract OPR 2022-0202—\$66,011 (incl. tax). (OPR 2024-0870) (Council Sponsors: Council Members Dillon, Cathcart, and Navarrete)

Report of the Mayor of pending claims and payments of previously approved obligations, including those of Parks and Library, through October 4, 2024, total \$10,949,675.78 (Check Nos.: 606103-606264; Credit Card Nos.: 000733-000758; ACH Payment Nos.: 133882-134084), with Parks and Library claims approved by their respective boards. Warrants excluding Parks and Library total \$10,620,288.02. (CPR 2024-0002)

Minutes:

- a. City Council Meeting Minutes: September 23, 2024. (CPR 2024-0013)
- b. City Council Public Safety and Community Health Standing Committee Meeting Minutes: September 9, 2024. (CPR 2024-0018)

## **LEGISLATIVE AGENDA**

There were no **Special Budget Ordinances**.

There were no **Emergency Ordinances**.

### **RESOLUTIONS**

**Resolution 2024-0093 (Council Sponsors: Council President Wilkerson and Council Members Cathcart and Zappone)**

After an opportunity for public testimony and Council commentary, with none provided, the following action was taken:

**Upon 7-0 Roll Call Vote**, the City Council **adopted Resolution 2024-0093** authorizing the Airport Board to sell property identified as a portion of Spokane County Assessor Parcel 15355.9007.

**Ayes:** Bingle, Cathcart, Dillon, Klitzke, Navarrete, Zappone, and Wilkerson

**Nos:** None

**Abstain:** None

**Absent:** None

**Resolution 2024-0094 (Council Sponsors: Council President Wilkerson and Council Members Cathcart and Zappone)**

After an opportunity for public testimony, with none provided, and Council commentary, the following action was taken:

**Upon 7-0 Roll Call Vote**, the City Council **adopted Resolution 2024-0094** authorizing the Airport Board to acquire property identified as Spokane County Assessor Parcels 24063.0102 and 24063.0510.

**Ayes:** Bingle, Cathcart, Dillon, Klitzke, Navarrete, Zappone, and Wilkerson  
**Nos:** None  
**Abstain:** None  
**Absent:** None

**Resolution 2024-0095 (Council Sponsors: Council President Wilkerson and Council Members Dillon and Zappone)**

After public testimony and Council commentary, the following action was taken:

**Upon 5-2 Roll Call Vote**, the City Council **adopted Resolution 2024-0095** stating the Spokane City Council's support for City of Spokane Proposition 1 entitled, "COMMUNITY SAFETY SALES TAX," submitted by the Spokane City Council for the November 5, 2024, General Election.

**Ayes:** Dillon, Klitzke, Navarrete, Zappone, and Wilkerson  
**Nos:** Bingle and Cathcart  
**Abstain:** None  
**Absent:** None

**FINAL READING ORDINANCES**

**Final Reading Ordinance C36571 (First Reading held September 9, 2024) (Council Sponsors: Council President Wilkerson and Council Members Klitzke and Cathcart)**

After public testimony and an opportunity for Council commentary, with none provided, the following action was taken:

**Upon 7-0 Roll Call Vote**, the City Council **passed Final Reading Ordinance C36571** granting to BNSF Railway Company, a Delaware Corporation, a franchise agreement for the right to construct, maintain, and operate a railway within certain described limits of the City of Spokane for a period of twenty-five (25) years.

**Ayes:** Bingle, Cathcart, Dillon, Klitzke, Navarrete, Wilkerson, and Zappone

**Nos:** None  
**Abstain:** None  
**Absent:** None

**Final Reading Ordinance C36576 (Council Sponsors: Council Members Dillon, Klitzke, and Zappone)**

Upon consideration of Final Reading Ordinance C36576, Council President Wilkerson announced that public testimony will be limited to two minutes due to the number of speakers that have signed up. Council Member Bingle presented a motion, seconded by Council Member Cathcart, to challenge the ruling. Discussion was held, and Council President Wilkerson withdrew the request to limit testimony to two minutes and that Council will stay at three minutes for the testimony. Council Member Bingle called a point of order and noted there was a motion and a second on the floor. The following action was taken:

**Motion** by Council Member Bingle, seconded by Council Member Cathcart, **to challenge** the ruling and keep the public testimony limit at three minutes; **carried 6-0.**

(Clerical Note: Council Member Cathcart left the dais at 7:19 p.m. and returned at that same time; however, he was not on the dais for the vote on the above action.)

After public testimony and Council commentary, the following action was taken:

**Upon 5-2 Roll Call Vote**, the City Council **passed Final Reading Ordinance C36576** streamlining rental registration requirements; amending sections 10.57.020, and 10.57.040 of the Spokane Municipal Code.

**Ayes:** Dillon, Klitzke, Navarrete, Wilkerson, and Zappone  
**Nos:** Bingle and Cathcart  
**Abstain:** None  
**Absent:** None

**Final Reading Ordinances C36586 through C36590 (Council Sponsors: Council President Wilkerson and Council Member Klitzke)**

(Clerical Note: Final Reading Ordinances C36586 through C36590 were considered prior to Council's consideration of Consent Agenda items.)

Public Works Director Marlene Feist provided a presentation and overview of Ordinances C36586 through C36590. After public testimony and Council commentary, the following actions were taken:

**Upon 4-3 Roll Call Vote**, the City Council **passed Final Reading Ordinance C36586** relating to the annual rates for the Sewer utility and services, amending SMC sections 13.03.1004, 13.03.1008, 13.03.1010,

13.03.1011, 13.03.1012, 13.03.1018, 13.03.1020, and 13.03.1022; to chapter 13.03 of the Spokane Municipal Code; repealing 13.03.1006; and setting an effective date.

**Ayes:** Dillon, Klitzke, Wilkerson, and Zappone  
**Nos:** Bingle, Cathcart, and Navarrete  
**Abstain:** None  
**Absent:** None

**Upon 4-3 Roll Call Vote, the City Council passed Final Reading Ordinance C36587** relating to the annual rates for the Water utility and services, amending SMC sections 13.04.2002, 13.04.2004, 13.04.2005, 13.04.2008, 13.04.2010, 13.04.2012, 13.04.2014, 13.04.2015, 13.04.2016, 13.04.20161, and 13.04.2025; to chapter 13.04 of the Spokane Municipal Code; and setting an effective date.

**Ayes:** Dillon, Klitzke, Wilkerson, and Zappone  
**Nos:** Bingle, Cathcart, and Navarrete  
**Abstain:** None  
**Absent:** None

**Upon 4-3 Roll Call Vote, the City Council passed Final Reading Ordinance C36588** relating to the annual rates of Water-Wastwater public utilities and services, amending SMC sections 13.035.500; to chapter 13.035 of the Spokane Municipal Code; and setting an effective date.

**Ayes:** Dillon, Klitzke, Wilkerson, and Zappone  
**Nos:** Bingle, Cathcart, and Navarrete  
**Abstain:** None  
**Absent:** None

**Upon 4-3 Roll Call Vote, the City Council passed Final Reading Ordinance C36589** relating to the rates of Solid Waste Collection public utilities and services, amending SMC sections 13.02.0106, 13.02.0112, 13.02.0114, 13.02.0125, 13.02.0130, 13.02.0202, 13.02.0204, 13.02.0224, 13.02.0232, 13.02.0238, 13.02.0244, 13.02.0300, 13.02.0304, 13.02.0306, 13.02.0310, 13.02.0314, 13.02.0316, 13.02.0318, 13.02.0324, 13.02.0330, 13.02.0332, 13.02.0334, 13.02.0340, 13.02.0342, 13.02.0344, 13.02.0352, 13.02.0354, 13.02.0358, 13.02.0360, 13.02.0364, 13.02.0366, 13.02.0402, 13.02.0406, 13.02.0408, 13.02.0410, 13.02.0502, 13.02.0504, 13.02.0506, 13.02.0508, 13.02.0510, 13.02.0512, 13.02.0514, 13.02.0518, 13.02.0520, 13.02.0522, 13.02.0528, 13.02.0550, 13.02.0552, 13.02.0554, 13.02.0560, 13.02.0561, 13.02.0562, 13.02.0563, and 13.02.0568; to chapter 13.02 of the Spokane Municipal Code; and setting an effective date.

**Ayes:** Dillon, Klitzke, Wilkerson, and Zappone

**Nos:** Bingle, Cathcart, and Navarrete  
**Abstain:** None  
**Absent:** None

**Upon 7-0 Roll Call Vote**, the City Council **passed Final Reading Ordinance C36590** relating to customer credit rate ordinance, amending SMC section 13.11.030; and SMC 13.035.700 of the Spokane Municipal Code; and setting an effective date.

**Ayes:** Bingle, Cathcart, Dillon, Klitzke, Navarrete, Wilkerson, and Zappone  
**Nos:** None  
**Abstain:** None  
**Absent:** None

There were no **First Reading Ordinances**.

There were no **Special Considerations**.

There were no **Hearings**.

[The City Clerk left the meeting at 8:17 p.m. (pursuant to Council Rule 2.2.A). Open Forum speaker information and motion of adjournment and adjournment time were provided by Council Director Giacobbe Byrd for the minutes.]

## **OPEN FORUM**

The following individual(s) spoke during the Open Forum:

- Katia Jasmin
- Will Hulings
- Julia McHugh
- C.J. Johnson
- Sunshine Wigen
- Cherrie Barnett
- Larry Andrews
- Will Thornton
- Faith Hayflich

**ADJOURNMENT**

**Motion** by Council Member Klitzke, seconded by Council Member Zappone, to adjourn; **carried 7-0.**

There being no further business to come before the City Council, the meeting adjourned at 8:38 p.m.

Minutes prepared by City Clerk Terri Pfister and submitted for publication in the October 30, 2024, issue of the *Official Gazette*.

Approved by Spokane City Council on November 4, 2024.

---

Betsy Wilkerson  
City Council President

Attest:

---

Terri Pfister  
City Clerk



# MINUTES OF SPOKANE CITY COUNCIL

Monday, October 21, 2024

## BRIEFING SESSION

The Briefing Session of the Spokane City Council held on the above date was called to order at 3:30 p.m. in the Council Chambers in the Lower Level of the Municipal Building, 808 West Spokane Falls Boulevard, Spokane, Washington. A recording of the meeting can be found at the following link: <https://vimeo.com/spokanecitycouncil>

### Roll Call

On roll call, Council President Wilkerson and Council Members Bingle (appearing virtually), Cathcart, Klitzke, Navarrete, and Zappone were present.

Interim City Administrator Garrett Jones; Giacobbe Byrd, Director-City Council Office; City Council Policy Advisor Chris Wright; and City Clerk Terri Pfister were also present for the meeting.

### Candidate Interviews – Climate Resilience and Sustainability Board

The City Council interviewed Dr. Bob Lutz, candidate for appointment to the Climate Resilience and Sustainability Board.

### Current Agenda Review

The City Council reviewed the October 21, 2024, Current Agenda.

Special Budget Ordinance C36592 (Council Sponsors: Council President Wilkerson and Council Member Zappone)

**Motion** by Council Member Zappone, seconded by Council Member Klitzke, **to adopt** the Wilkerson Proposed Amendment to Special Budget Ordinance C36592—arising from the need to re-allocate ARPA funding for other purposes—filed October 16, 2024, at the request of Administration; **carried 6-1.**

**Motion** by Council Member Cathcart, seconded by Council Member Bingle, **to adopt** the Cathcart Proposed Amendment No.2 to Special Budget Ordinance C36592—arising from the need to re-allocate ARPA funding for other purposes—filed October 18, 2024; **failed 3-4.**

### Action to Reconsider Climate Resilience & Sustainability Board (OPR 2024-0030)

**Motion** by Council Member Klitzke, seconded by Council Member Zappone, **to bring back** for reconsideration on the October 28, 2024, Agenda, the five Climate Resilience & Sustainability Board appointments previously made on October 14, 2024; **carried 7-0.**

Final Reading Ordinance C36120 (First Reading held October 25, 2021) (Deferred from September 23, 2024, Agenda) (Council Sponsors: Council Members Zappone and Klitzke)

**Motion** by Council Member Zappone, seconded by Council Member Klitzke, **to defer** Final Reading Ordinance C36120—vacating the east 55 feet of Adams Street from the south line of Third Avenue to the north line of I-90, together with the alley between Third Avenue and I-90, from the east line of Adams Street to the west line of Jefferson Street—to December 2, 2024, Agenda; **carried 7-0.**

### **Advance Agenda Review**

The City Council received an overview of the October 28, 2024, Advance Agenda items.

Resolution 2024-0097 (Council Sponsors: Council Members Bingle, Zappone, and Klitzke)

**Motion** by Council Member Klitzke, seconded by Council Member Zappone, **to indefinitely defer** Resolution 2024-0097 setting hearing before the City Council for December 2, 2024, for the vacation of the alley between 2<sup>nd</sup> Avenue and 3<sup>rd</sup> Avenue from the east line of Post Street to the west line of Wall Street, as requested by Avista Utilities; **carried 7-0.**

Contract Extensions for Operation Support and Services (OPR 2019-0964, OPR 2019-0965, OPR 2019-0966, and OPR 2017-0711) (Council Sponsors: Council Members Bingle, Zappone, and Klitzke)

**Motion** by Council Member Zappone, seconded by Council Member Klitzke, **to defer indefinitely** the Contract Extensions for operational support and services from January 1, 2025, to December 31, 2025, with the following; **carried 6-1:**

- a. Northeast Community Center-\$150,000. (OPR 2019-064)
- b. Southwest Community Center-\$40,000. (OPR 2019-0965)
- c. West Central Community Center-\$150,000. (OPR 2019-0966)
- d. Dr. Martin Luther King Jr. Community Center-\$243,000. (OPR 2017-0711)

### **Action to Approve October 28, 2024, Advance Agenda**

Following staff reports and Council inquiry and discussion regarding the October 28, 2024, Advance Agenda items, the City Council took the following action (pursuant to Council Rule 2.1.B):

**Motion** by Council Member Klitzke, seconded by Council Member Dillon, **to approve** the October 28, 2024, Advance Agenda (as modified); **carried 7-0.**

### **Council Recess/Executive Session**

The City Council recessed at 4:07 p.m. No Executive Session was held. The City Council reconvened at 6:01 p.m. for the Legislative Session.

## **LEGISLATIVE SESSION**

### **Recognition of Gonzaga Students**

Council President Wilkerson recognized Gonzaga students who were in the audience attending this evening's meeting.

### **Land Acknowledgement**

Council President Wilkerson started the meeting off by reading the "Land Acknowledgement" (adopted by City Council on March 22, 2021, under Resolution 2021-0019) which appears on page 2 of the agenda.

### **Pledge of Allegiance**

The Pledge of Allegiance was led by Council President Wilkerson.

### **Roll Call**

On roll call, Council President Wilkerson and Council Members Cathcart, Dillon, Klitzke, Navarrete, and Zappone were present. Council Member Bingle was absent.

Giacobbe Byrd, Director-City Council Office; City Council Policy Advisor Chris Wright; and City Clerk Terri Pfister were also present for the meeting.

## **COUNCIL SALUTATION**

Council Member Cathcart read a Council Salutation saluting the public service of election workers. County Auditor Vicky Dalton accepted the Salutation and provided remarks.

The Council Salutation is attached to these minutes for reference.

## **REPORTS FROM COMMUNITY ORGANIZATIONS**

### **State of Urban Indigenous People**

Toni Lodge, Executive Director of the Native Project, provided a presentation on the State of Urban Indigenous People.

## **BOARD AND COMMISSION APPOINTMENTS**

**Appointments to Climate Resilience & Sustainability Board (CPR 2024-0030), Transportation Commission (CPR 2024-0029), and Design Review Board (CPR 1993-0069)**

After public testimony and Council commentary, the following actions were taken:

**Upon 5-1 Voice Vote**, the City Council **approved (and thereby confirmed)** the appointments of Kerry Brooks, Kevin Fagan, Lea Molina, and Hala Zahalqa to the Climate Resilience & Sustainability Board for two-year terms from October 21, 2024, to October 21, 2026.

**Upon 6-0 Voice Vote**, the City Council **approved (and thereby confirmed)** the appointment of Lauren Pangborn to the Transportation Commission for a one-year term from October 21, 2024, to October 21, 2025.

**Upon 6-0 Voice Vote**, the City Council **approved (and thereby confirmed)** the appointment of Carlos Fernando Diaz Garcia to the Design Review Board for a three-year term from October 21, 2024, to October 21, 2027.

## **CONSENT AGENDA**

After public testimony and an opportunity for Council commentary, with none provided, the following action was taken:

**Upon 6-0 Voice Vote**, the City Council **approved** Staff Recommendations for the following items;

Two-year Value Blanket with San Diego Police Equipment (San Diego, CA) for the purchase of ammunition for the Spokane Police Department—not to exceed \$195,000 annually. (OPR 2024-0886 / RFQ 6228-24) (Council Sponsors: Council Members Dillon, Cathcart, and Navarrete)

On-call Master Agreements utilizing Community Wildfire Defense Grant funds for wildland fuels reduction for the Spokane Fire Department with:

- a. American Forest Management—\$300,000. (OPR 2024-0887 / RFP 6161-24)
- b. Patriot Land Management—\$200,000. (OPR 2024-0888 / RFP 6161-24)
- c. American Fire Fighter Co.—\$150,000. (OPR 2024-0889 / RFP 6161-24)

(Council Sponsors: Council Members Dillon, Cathcart, and Navarrete)

Brush and Fuels Service Agreement with the Washington State Department of Ecology utilizing Community Wildfire Defense Grant funds to provide Washington Conservation Corps members to complete environmental or disaster services projects for the Spokane

Fire Department from October 1, 2024, through September 30, 2025—\$54,015. (OPR 2024-0890) (Council Sponsors: Council Members Dillon, Cathcart, and Navarrete)

Consultant Agreement with Engineering Economics, Inc. (Lakewood, CO) for mechanical systems commissioning services at the Water Department Building from October 21, 2024, through June 30, 2028—\$61,067.25 (incl. tax) (plus 10% administrative reserve). (OPR 2024-0891) (Council Sponsors: Council President Wilkerson and Council Members Cathcart and Dillon)

Amendment to Master Software Services Agreement with Washtech Corp. (Portland, OR) for software services formerly provided by Rubicon Global LLC from October 1, 2024, through September 30, 2029—\$682,746 (\$136,549.20 annually) (plus applicable tax). (OPR 2023-1015 / RFP 4430-18) (Council Sponsors: Council President Wilkerson and Council Members Cathcart and Zappone)

Memorandum of Understanding with Neighborhood Housing & Human Services Division and Utility Billing regarding the Residential Lighting Program utilizing ARPA funds—\$150,000. (OPR 2024-0892) (Council Sponsors: Council President Wilkerson and Council Members Cathcart and Dillon)

Report of the Mayor of pending:

- a. Claims and payments of previously approved obligations, including those of Parks and Library, through October 11, 2024, total \$8,401,846.76 (Check Nos.: 606265-606398; Credit Card Nos.: 000759-000793; ACH Nos.: 134085-134282), with Parks and Library claims approved by their respective boards. Warrants excluding Parks and Library total \$8,154,266.72. (CPR 2024-0002)
- b. Payroll claims of previously approved obligations through October 12, 2024: \$9,457,527.27 (Check Nos.: 574682-574811). (CPR 2024-0003)

Minutes:

- a. City Council Meeting Minutes: September 30, 2024. (CPR 2024-0013)
- b. City Council Finance and Administration Standing Committee Meeting Minutes: August 26 and September 23, 2024. (CPR 2024-0015)
- c. City Council Urban Experience Standing Committee Meeting Minutes: October 14, 2024. (CPR 2024-0017)

## **LEGISLATIVE AGENDA**

### **SPECIAL BUDGET ORDINANCES**

**Special Budget Ordinance C36592 (As amended during the 3:30 p.m. Briefing Session) (Council Sponsors: Council President Wilkerson and Council Member Zappone)**

After public testimony and Council commentary, the following action was taken:

**Upon 5-1 Roll Call Vote**, the City Council **passed Special Budget Ordinance C36592**, as amended, amending Ordinance No. C36467 passed by the City Council November 27, 2023, and entitled, "An Ordinance adopting the Annual Budget of the City of Spokane for 2024, making appropriations to the various funds of the City of Spokane government for the fiscal year ending December 31, 2024, and providing it shall take effect immediately upon passage," and declaring an emergency and appropriating funds in:

American Rescue Plan Fund

- 1) Reallocate the appropriation of \$7,484.09 that was previously allocated for the purpose of AVI Upgrades.
- 2) Reallocate the appropriation of \$218,632.84 that was previously allocated for the purpose of procurement and outfitting of fire apparatuses.
- 3) Reallocate the appropriation of \$9,504.88 that was previously allocated for ADU Permits.
- 4) Reallocate the appropriation of \$6,130.41 that was previously allocated for the purpose of purchase and commissioning of a Fire Safety House.
- 5) Reallocate the appropriation of \$16,733.09 that was previously allocated for the purpose of purchasing police vehicles.
- 6) Reallocate the appropriation of \$4,187.29 that was previously allocated for the purpose of Chief Recruitment.
- 7) Reallocate the appropriation of \$30,008.09 that was previously allocated for the purpose of subarea planning for Hillyard, West Central and East Central.
- 8) Reallocate the appropriation of \$31,800 that was previously allocated for the purpose of Multi Cultural Centers.
- 9) Reallocate the appropriation of \$100,000 that was previously allocated for the purpose of Police Ombudsman
- 10) Reallocate the appropriation of \$11,341.32 that was previously allocated for a Behavioral Health Services Vehicle
- 11) Of the reallocated appropriation, \$169,684.01 is provided solely for Fire Capital at Station 1 for HVAC
- 12) Of the reallocated appropriation, \$6,138 is provided solely for sales taxes on WUI Fire software contract.
- 13) Of the reallocated appropriation, \$200,000 is provided solely for Latah Valley TIF analysis & sub area planning.
- 14) Of the reallocated appropriation, \$60,000 is provided solely for a memory garden.

(This action arises from the need to re-allocate ARPA funding for other purposes.)

**Ayes:** Dillon, Klitzke, Navarrete, Wilkerson, and Zappone

**Nos:** Cathcart  
**Abstain:** None  
**Absent:** Bingle

**Special Budget Ordinance C36593 (Council Sponsors: Council President Wilkerson and Council Members Dillon and Cathcart)**

After public testimony and an opportunity for Council commentary, with none provided, the following action was taken:

**Upon 6-0 Roll Call Vote**, the City Council **passed Special Budget Ordinance C36593** amending Ordinance No. C36467 passed by the City Council November 27, 2023, and entitled, "An Ordinance adopting the Annual Budget of the City of Spokane for 2024, making appropriations to the various funds of the City of Spokane government for the fiscal year ending December 31, 2024, and providing it shall take effect immediately upon passage," and declaring an emergency and appropriating funds in:

Public Safety Personnel & Crime Reduction Fund

- 1) Remove 16 classified Police Officers (from 16 to 0).
- 2) Remove one classified Senior Police Officer (from 1 to 0).
- 3) Remove one classified Mental Health Coordinator (from 1 to 0).
- 4) Remove two classified Parking Enforcement Spec I (from 2 to 0).
- 5) Remove four classified Police Records Specialist (from 4 to 0).
- 6) Remove six classified Police Radio Dispatcher I (from 6 to 0).
- 7) Remove two classified Police Radio Dispatcher II (from 2 to 0).
- 8) Decrease appropriation by \$3,119,373.
  - A) Of the decreased appropriation, \$3,119,373 is removed from base wages and employee benefits.
- 9) Increase appropriation by \$3,119,373.
  - A) Of the increased appropriation, \$3,119,373 is provided solely for an operating transfer-out to the General Fund's Police department.

and

General Fund

- 1) Add 16 classified Police Officers (from 76 to 92).
- 2) Add one classified Senior Police Officer (from 106 to 107).
- 3) Add one classified Mental Health Coordinator (from 0 to 1).
- 4) Add two classified Parking Enforcement Spec I (from 0 to 2).
- 5) Add four classified Police Records Specialist (from 20 to 24).
- 6) Add six classified Police Radio Dispatcher I (from 4 to 10).
- 7) Add two classified Police Radio Dispatcher II (from 2 to 4).
- 8) Increase revenue by \$3,119,373.
  - A) Of the increased revenue, \$3,119,373 is provided solely for an operating transfer-in from the Public Safety Personnel & Crime Reduction Fund.
- 9) Increase appropriation by \$3,119,373.

A) Of the increased appropriation, \$3,119,373 is provided solely for base wages and employee benefits.

(This action arises from transferring the Police FTE and the associated personnel budget from the Public Safety Personnel & Crime Reduction Fund to the General Fund.)

**Ayes:** Cathcart, Dillon, Klitzke, Navarrete, Wilkerson, and Zappone  
**Nos:** None  
**Abstain:** None  
**Absent:** Bingle

### **EMERGENCY ORDINANCE**

#### **Emergency Ordinance C36594 (Council Sponsors: Council President Wilkerson and Council Member Zappone)**

After an opportunity for public testimony, with none provided, and Council commentary, the following action was taken:

**Upon 6-0 Roll Call Vote**, the City Council **passed Emergency Ordinance C36594** repealing reduced fees for construction of accessory dwelling units; amending sections 08.02.031 and 08.02.066 of the Spokane Municipal Code.; and declaring an emergency.

**Ayes:** Cathcart, Dillon, Klitzke, Navarrete, Zappone, and Wilkerson  
**Nos:** None  
**Abstain:** None  
**Absent:** Bingle

There were no **Resolutions**.

### **FINAL READING ORDINANCE**

**For Council action on Final Reading Ordinance C36120, see section of minutes under 3:30 p.m. Briefing Session.**

There were no **First Reading Ordinances**.

There were no **Special Considerations**.

There were no **Hearings**.



[The City Clerk left the meeting at 7:06 p.m. (pursuant to Council Rule 2.2.A). Open Forum speaker information and motion of adjournment and adjournment time were provided by Council Director Giacobbe Byrd for the minutes.]

## OPEN FORUM

Council President Wilkerson reviewed the rules of decorum for open forum. The following individual(s) spoke during the Open Forum:

- Christopher Savage
- Chesed Johnson (C.J.)
- Will Hulings
- Rick Bocook
- Justin Haller
- Derek Azzaro
- Larry Andrews
- Raul Pena
- Dave Bilisland
- Monica Tittle

## ADJOURNMENT

**Motion** by Council Member Dillon, seconded by Council Member Klitzke, **to adjourn; carried 6-0.**

There being no further business to come before the City Council, the meeting adjourned at 7:29 p.m.

Minutes prepared by City Clerk Terri Pfister and submitted for publication in the October 30, 2024, issue of the *Official Gazette*.

Approved by Spokane City Council on November 4, 2024.

---

Betsy Wilkerson  
City Council President

Attest:

---

Terri Pfister  
City Clerk

**MEETING MINUTES**  
**City of Spokane**  
**City Council Study Session**  
**Council Chambers, City Hall (808 W Spokane Falls Blvd)**  
**October 24, 2024**

---

**Meeting Recording:** <https://vimeo.com/1023018494>

**Call to Order:** 11:05 a.m.

**Attendance:**

Committee Members Present: Council President Wilkerson, Council Members Zappone, Cathcart, Bingle, Dillon, Navarrete, and Klitzke

Council Members Absent: none

**Agenda Items:**

- Discussion on Periodic Update to the Comprehensive Plan - Tirrell Black
- Review of Draft 2025-2030 Citywide Capital Improvement Program (CIP) - Jessica Stratton

**Executive Session:**

None

**Adjournment:**

The meeting adjourned at 11:47 a.m.

Minutes prepared and submitted for publication in the Noissue of the Official Gazette.

---

Giacobbe Byrd  
Director, Council Office

Approved by City Council on November 4, 2024.

---

Betsy Wilkerson  
City Council President

Attest:

---

Terri L. Pfister  
City Clerk

**STANDING COMMITTEE MINUTES**  
**City of Spokane**  
**Public Safety & Community Health**  
**City Hall (808 W. Spokane Falls Blvd), Council Chambers**  
**October 7, 2024**

---

**Call to Order: 1:17 PM**

Recording of the meeting may be viewed here: [Spokane City Council \(vimeo.com\)](https://www.vimeo.com/spokane-city-council)

**Monthly Report/Update**

SFD Monthly Report – Chief O/Berg  
SPD Monthly Report – Chief Hall  
0680 – Photo Red Monthly Update  
0680 – Strategic Initiatives Monthly Update  
OPO Monthly Report – Bart Logue  
0680 – Uniform Overtime Report – Kevin Schmitt

**Discussion items**

1. 0320 – Resolution Supporting City of Spokane Proposition 1
2. 0320 – Spokane Cops Opportunity for Questions and Discussion
3. 0320 – Ordinance Expanding City and Lie Prohibition City Wide
4. 0520 – Mayors Office – Establishing the Community Safety Fund
5. MOU for Residential Lighting Program Using ARPA Funds
6. 0410 – SBO Public Safety Personnel Fund Use

**Consent items**

1. 1970 – On Call Master Agreements for Wildland Fuels Reduction – Patriot Land
2. 1970 – On-Call Master Agreement for Wildland Fuels Reduction – Majestic View
3. 5900 – Facilities Dept Water Dept Main Bldg. Reh & Restore Owners Rep. Commission
4. 1970 – Brush and Fuels Service Agreement with Department of Ecology
5. 1970 – On Call Master Agreement for Wildland Fuels Reduction – American Fire
6. 0680 – 1970 – STARS Vehicle Purchase Approval
7. 0680 – Approval of Value Blanket for Police Department Ammunition
8. 1970 – On-Call Master Agreements for Wildland Fuels Reduction – American Forest
9. 5300 – Rubicon Global, LLC 5-year Software Maintenance and Support

**Executive session**

None.

**Adjournment**

The meeting adjourned at 3:09 PM

Minutes prepared and submitted for publication in the XXX XX, 2024, issue of the Official Gazette.

Prepared by:  
Virginia Ramos

Approved by:

---

Insert your name and role

Approved by City Council on XXX XX, 2024.

---

Betsy Wilkerson  
City Council President

Attest:

---

Terri L. Pfister  
City Clerk

**Agenda Sheet for City Council:****Committee:** Finance & Administration **Date:** 09/23/2024**Committee Agenda type:** Discussion**Date Rec'd**

8/21/2024

**Clerk's File #**

ORD C36570

**Cross Ref #****Project #****Council Meeting Date:** 10/14/2024**Submitting Dept**

CITY COUNCIL

**Bid #****Contact Name/Phone**

MICHAEL CATHCART 625-6257

**Requisition #****Contact E-Mail**

MCATHCART@SPOKANECITY.ORG

**Agenda Item Type**

Emergency Ordinance

**Council Sponsor(s)**

MCATHCART JBINGLE

**Agenda Item Name**

0320 - SITING OF CITY-OWNED AND CITY-FUNDED SUPPORT FACILITIES

**Agenda Wording**

Emergency ordinance relating to the siting of city-owned and city-funded facilities providing comprehensive support services.

**Summary (Background)**

Current municipal code governs the siting of city-owned shelters and provides for both public outreach and good neighbor agreements prior to siting a homeless shelter facility. The proposed ordinance would expand the current code requirements to included city-funded facilities, and expands the scope to shelters and facilities providing comprehensive support services. The ordinance further outlines the requirements for good neighbor agreements. This is an emergency ordinance.

Lease? NO

Grant related? NO

Public Works? YES

**Fiscal Impact**

Approved in Current Year Budget? N/A

Total Cost

\$

Current Year Cost

\$

Subsequent Year(s) Cost

\$

**Narrative**

Some operational impact is assumed because the public outreach and prerequisites for siting city facilities are expanded, but those impacts have not been identified nor any fiscal cost associated with them quantified.

**Amount****Budget Account**

Select

\$

#

Select

\$

#

Select

\$

#

Select

\$

#

\$

#

\$

#





## Committee Briefing Paper

### Finance & Administration Committee

<b>Committee Date</b>	08/26/24
<b>Submitting Department</b>	City Council
<b>Contact Name</b>	Shae Blackwell
<b>Contact Email &amp; Phone</b>	<a href="mailto:sblackwell@spokanecity.org">sblackwell@spokanecity.org</a> / 625-6224
<b>Council Sponsor(s)</b>	CM Cathcart, CM Bingle
<b>Select Agenda Item Type</b>	<input type="checkbox"/> Consent <input checked="" type="checkbox"/> Discussion    Time Requested:
<b>Agenda Item Name</b>	Emergency Ordinance re siting of comprehensive support facilities
<b>Proposed Council Action</b>	<input checked="" type="checkbox"/> Approval to proceed to Legislative Agenda <input type="checkbox"/> Information Only
<b>Summary (Background)</b>	<p>*use the Fiscal Impact box below for relevant financial information</p> <p>SMC 12.05.062 and 12.05.063 currently governs the siting of city facilities, including homeless shelters, and provides for both public outreach and good neighbor agreements prior to siting a city-owned homeless shelter facility. The proposed ordinance would expand the current code requirements to included city-funded as well as city-owned facilities, and expands the beyond shelters to any facility providing comprehensive support services, which are defined in the ordinance. The ordinance further outlines the requirements for good neighbor agreements and imposes other restrictions.</p> <p>This is an emergency ordinance and includes recitals to comply with recently adopted SMC 01.01.080.</p>
<b>Fiscal Impact</b>	
<b>Approved in current year budget?</b> <input type="checkbox"/> Yes <input type="checkbox"/> No <input checked="" type="checkbox"/> N/A Total Cost: <a href="#">Click or tap here to enter text.</a> Current year cost: Subsequent year(s) cost:	
<b>Narrative:</b> <u>Some operational impact is assumed because the public outreach and prerequisites for siting city facilities are expanded, but those impacts have not been identified nor any fiscal cost associated with them quantified.</u>	
<b>Funding Source</b> <input type="checkbox"/> One-time <input type="checkbox"/> Recurring <input checked="" type="checkbox"/> N/A Specify funding source: Select Funding Source* Is this funding source sustainable for future years, months, etc? <a href="#">Click or tap here to enter text.</a>	
<b>Expense Occurrence</b> <input type="checkbox"/> One-time <input type="checkbox"/> Recurring <input checked="" type="checkbox"/> N/A  Other budget impacts: (revenue generating, match requirements, etc.)	
<b>Operations Impacts (If N/A, please give a brief description as to why)</b>	
<ul style="list-style-type: none"> <li>• What impacts would the proposal have on historically excluded communities?</li> </ul> <p style="text-align: center;"><b>None identified.</b></p>	

- How will data be collected, analyzed, and reported concerning the effect of the program/policy by racial, ethnic, gender identity, national origin, income level, disability, sexual orientation, or other existing disparities?

**Unknown**

- How will data be collected regarding the effectiveness of this program, policy, or product to ensure it is the right solution?

**The ordinance is intended to ensure full outreach, and to ensure implementation of measures to mitigate the impacts of certain facilities on nearby businesses and residents. The measures implemented should provide data and information on the success of the outreach and efforts to minimize negative impacts of such facilities.**

- Describe how this proposal aligns with current City Policies, including the Comprehensive Plan, Sustainability Action Plan, Capital Improvement Program, Neighborhood Master Plans, Council Resolutions, and others?

**The ordinance is an expansion of current city policy as reflected in SMC 12.05.062 and 12.05.063.**

**Council Subcommittee Review**

- Please provide a summary of council subcommittee review. If not reviewed by a council subcommittee, please explain why not.

**ORDINANCE NO. C36570**

AN ORDINANCE relating to the siting and operation of city-owned and city-funded facilities, amending Sections 12.05.005, 12.05.062, and 12.05.063 of the Spokane Municipal Code, and declaring an emergency.

WHEREAS, the administration is intending to implement a strategy of siting shelters and other centers serving the homeless population throughout the city in a “scattered site” model; and

WHEREAS, the City Council supports the decentralized and “scattered site” approach to delivery of homeless services and siting of shelters and other facilities; and

WHEREAS, while supportive of the “scattered site” model, the City Council has long been mindful that locating homeless services in small business centers, neighborhoods and residential areas can have a negative impact on those areas without adequate planning to minimize the impacts;

WHEREAS, services for the homeless population historically have been situated in the downtown district and are predominantly located in lower income areas of Council District 1; and

WHEREAS, almost exactly two years ago, the Spokane City Council adopted Ordinance C36239 regarding the siting of City-owned facilities, including shelters, observing at the time:

.... public input, collaboration, and cooperation are all critical to the successful process of locating basic City facilities, to ensure that neighborhoods obtain all the benefits of basic city facilities while mitigating the detrimental impacts of those facilities; and

.... members of our community, regardless of where they live, their race, ethnicity, socio-economic status, or any other characteristic, deserve to have the benefit of open, collaborative and transparent interactions with their local government, particularly when it comes to decisions to locate or relocate basic city facilities in their neighborhoods; and

WHEREAS, Ordinance C36239, now codified as SMC Sections 12.05.062 and 12.05.063, requires public outreach and “good neighbor agreements” before siting of city-owned shelters; and

WHEREAS, the “scattered site” amounts to an expansion of city-funded facilities for the homeless but not necessarily “City-owned” shelters or related facilities, and by their terms SMC sections 12.05.062 and 12.05.063 would not apply to facilities not owned by the City but otherwise funded in part or in whole by the City; and

WHEREAS, to ensure the success of the “scattered site” model and to prevent the distrust of local government that arises from unilateral decisions to support the placement of city-funded shelters and homeless service in small business centers, neighborhoods and residential areas, the City

Council desires to amend the Spokane Municipal Code to ensure the placement of facilities under the “scattered site” model comply with the spirit and letter of Ordinance C36239; and

WHEREAS, the City must implement its comprehensive “scattered site” shelter plan as quickly as possible with the anticipated closure of the Trent Resource and Assistance Center, and such urgency is likely to override local concerns over siting of facilities unless a legal framework is enacted as quickly as possible to regulate the siting of both city-funded facilities as well as City-owned facilities; and

WHEREAS, the urgency to implement a scattered site plan, and the competing urgency to preserve the interests of small business centers, neighborhoods and residential areas, requires enactment of amendments to SMC sections 12.05.062 and 12.05.063 as soon as possible, in less than 30 days; and

WHEREAS, the administration’s implementation of the scattered site model outside the parameters of Ordinance C36239 is sudden, unexpected, and requires immediate action to prevent or mitigate the threat to small business centers, neighborhoods and residential areas; and

WHEREAS, the normal course of legislative procedures of the City Council cannot result in a timely expansion SMC sections 12.05.062 and 12.05.063 to ensure those provisions apply to both City-owned as well as City-funded facilities nor will it ensure the use of good neighbor agreements anticipated under the current municipal code provisions; and

WHEREAS, this ordinance is necessary for the immediate preservation of the public peace, health or safety or for the immediate support of City government and its existing public institutions,

NOW THEREFORE, the City of Spokane does ordain:

**Section 1.** Adoption of Findings.

Pursuant to Section 01.01.080 of the Spokane Municipal Code, the City Council adopts the foregoing recitals as findings in support of this emergency ordinance.

**Section 2.** Section 12.05.005 of the Spokane Municipal Code is amended as follows:

[Section 12.05.005](#) Definitions

- A. “Agent” means any person acting within the scope of employment by or acting on behalf of the City of Spokane including City-facility property managers.
- B. “Baby changing facility” means a table or other device suitable for changing the diaper of a child.

C. "Employee" means any person holding a regularly compensated position of employment with the City of Spokane including elected officers.

D. "Basic City Facility" or "Basic City Facilities" means public safety facilities, including fire and police stations, City-owned water reservoirs, and other utility facilities, city-owned ~~((homeless shelters))~~ and city-funded facilities providing comprehensive support services, and community centers. Provided that, utility facilities shall not include privately constructed utility facilities, stormwater facilities and conveyance systems, or water and wastewater utility transmission and distribution systems and related appurtenances, to include without limitation, pipe replacements and relocations; well upgrades; pump stations; lift stations, etc.

E. "City-funded facility" or "city-funded facilities" with respect to a facility providing comprehensive support services means a facility receiving any of its operating or capital expenditures from the city's general fund or special revenue or tax funds or broad based grants in any calendar year, but excluding from those expenditures any funds from other public or private sources for which the city is merely a fiscal or pass-thru agent.

F. "Comprehensive support services" means services encompassing addiction recovery services, resource distribution centers, congregate shelters, transitional or non-permanent housing. Such services include, but are not limited to, behavioral health services providers as defined in RCW 71.05.020.

((E)) G. "Federal civil immigration enforcement operations" means an operation than has one of its objectives the identification or apprehension of a person or persons in order to investigate them for a violation of the immigration law and subject them to one or more of the following:

1. Civil immigration detention;
2. Removal proceedings; and
3. Removal from the United States

((F)) H. "Good neighbor agreement" means a written agreement for communication and collaboration and which contains the following framework:

1. Establishment of a community roundtable consisting of at least the following stakeholders, each of whom commits to the requirements of this subsection H:
  - a. Representative of the city-funded facility operator;
  - b. Neighborhood council chair or designee;
  - c. Representative of each business district, business association, or BID that is within 1/4 mile of the facility;
  - d. City of Spokane Neighborhood Services;

- e. City of Spokane Police Department;
  - f. City of Spokane Code Enforcement;
  - g. Local representative of the funding agency for the facility; and
  - h. All immediately adjacent property owners, residents, and tenants.
2. Commitment of the community roundtable to meet at least monthly and to fulfill the following goals:
- a. Start and maintain open communication and understanding between the named parties in order to be responsible partners and neighbors to each other;
  - b. Develop procedures for resolving problems that may arise in the future;
  - c. Encourage early communication to identify and resolve differences;
  - d. Encourage a high level of high quality care and investment in the neighborhood;
  - e. Maintain and enhance public safety and livability;
  - f. Reduce crime in the neighborhood;
  - g. Contribute to the safety and well-being of everyone in the community by committing to treat everyone with respect;
  - h. Communicate with one another productively when questions, problems or differences arise, and resolve concerns at the lowest possible level; and
  - i. Foster a safe and welcoming community for everyone.
3. Commitment to maintain a website containing project information (type of facility, specific services, etc), a list of contacts for each named party, and a copy of the executed Good Neighbor Agreement.

((F)) I. "LEED" is a green building rating and certification system developed by the U.S. Green Building Council to evaluate environmental performance from a whole building perspective, including sites, water efficiency, energy & atmosphere, materials & resources, indoor environmental quality, locations & linkages, awareness & education, innovation in design, and regional priority.

((G)) J. "Nonpublic" means any area of a city facility or property that is not generally open and accessible to the general public, but instead requires prior to entry express permission, such as a valid ticket for a bona fide passenger, or permission by a city employee or an employee of a tenant in a city facility on an individual basis. Areas posted as "Restricted" in City facilities shall be considered to be non-public areas.

((H)) K. "United States Citizenship and Immigration Services" means the agency of the United States Department of Homeland Security and any successor agency charged with overseeing United States immigration laws.

((I)) L. “United States Customs and Border Protection” means the agency of the United States Department of Homeland Security and shall include any successor federal agency charged with border enforcement.

((K)) M. “United States Immigration and Customs Enforcement” means the agency of the United States Department of Homeland Security including Enforcement and Removal Operations and Homeland Security Investigations and shall include any successor federal agency charged with the enforcement of immigration laws.

((L)) N. “U.S. Green Building Council” is an organization serving as the nation’s foremost leaders from across the building industry working to promote buildings that are environmentally responsible, profitable, and healthy places to work and live.

**Section 3. 12.05.062 of the Spokane municipal code is amended as follows:**

Section 12.05.062 Siting of Basic City Facilities – Process

A. Prior to locating a Basic City Facility, or prior to locating, re-locating, re-opening, or funding a city-owned and/or city-funded facility providing comprehensive support services, the city shall undertake the following public process((-):

1. Convene at least one public community meeting and solicit written comment from members of the affected neighborhood council area(s) concerning the need(s) for the facility and the service(s) desired or required by the community, as well as identified service gap(s) to be addressed by the facility.
2. Publish any alternative locations considered for the proposed new or relocated Basic City Facility, to enable the residents of the affected neighborhood(s) of the relative merits and compliance with SMC 12.05.063 of each proposed alternative location and solicit comment on the proposed alternative locations in at least one open public meeting held in the affected neighborhood(s).

B. The Spokane City Council’s Equity Subcommittee shall review all responsive proposals and make a recommendation to the City Council based on at least the following criteria, to be given equal weight:

1. effective demonstrably needed service to impacted neighborhood residents;
2. responsiveness of the location to the demonstrated needs of the residents of an impacted neighborhood; ~~((and))~~
3. financial sustainability of the location;
4. evaluation of proposed comprehensive strategies for mitigation and prevention of any anticipated or unanticipated nuisance and/or criminal activity impacting surrounding neighborhood;
5. consideration of geographic equity, evaluating both current and historic distribution patterns of highly impactful services; and

6. the proposed Good Neighbor Agreement to be executed in connection with the facility.

- C. City services shall not be provided at the location unless the City Council has approved the location or relocation of a Basic City Facility. The locating, re-opening, re-locating or funding of a city-owned and/or city-funded facility providing comprehensive support services shall be approved by the city council, regardless of the amount of the fiscal commitment of the City to facility.

**Section 4. 12.05.063 of the Spokane municipal code is amended as follows:**

**Section 12.05.063 Basic City Facilities – Criteria**

- A. The following criteria shall be met before any decision to place a new or relocated Basic City Facility can be made:
1. For police precincts, the chosen location shall:
    - a. be visible to the public in a frequently-traveled location;
    - b. provide access for the public to onsite services and for officers responding to reports of crime;
    - c. be located within high visibility of patrol cars, foot and bicycle community policing patrols; and
    - d. provide adequate space and facilities for co-deployed services and reception provided through mutual agreement with Spokane C.O.P.S.
  2. For utility facilities:
    - a. the location must be designed to minimize conflicts with traffic to the extent consistent with efficient operations.
    - b. the location must be designed and operated to minimize noise, odor, dust, or other negative impacts due to the operation of the facility to the extent consistent with efficient operations.
  3. For city-owned (~~((homeless shelters))~~) and city-funded facilities providing comprehensive support services:
    - a. the location shall not be located within (~~((three blocks))~~) 1000 feet of schools;
    - b. the location must be accessible by public transportation; and
    - c. a good neighbor agreement must be executed and in place (~~((between the shelter provider and the surrounding businesses and the applicable neighborhood council))~~).
    - d. The physical space must maintain an internal courtyard or equivalent, to enable the prohibition of external loitering that may create a nuisance for neighbors.



**Section 5.** Severability. If any section, subsection, sentence, clause, phrase or word of this ordinance should be held to be invalid or unconstitutional by a court of competent jurisdiction, such invalidity or unconstitutionality thereof shall not affect the validity or constitutionality of any other section, subsection, sentence, clause, phrase or word of this ordinance.

**Section 6.** Clerical Errors. Upon approval by the city attorney, the city clerk is authorized to make necessary corrections to this ordinance, including scrivener’s errors or clerical mistakes; references to other local, state, or federal laws, rules, or regulations; or numbering or referencing of ordinances or their sections and subsections.

**Section 7.** Emergency Findings. Pursuant to Section 01.01.080 Spokane Municipal Code, the City Council declares that an urgency and emergency exists such that this ordinance is needed for the immediate preservation of the public peace, health, or safety, and/or for the immediate support of City government and its existing public institutions, and that because of such need, this ordinance shall be effective immediately under Section 19 of the City Charter, upon the affirmative vote of five members of the City Council.

PASSED by the City Council on \_\_\_\_\_

\_\_\_\_\_  
Council President

Attest:

Approved as to form:

\_\_\_\_\_  
City Clerk

\_\_\_\_\_  
City Attorney

\_\_\_\_\_  
Mayor

\_\_\_\_\_  
Date

\_\_\_\_\_  
Effective Date



**Agenda Sheet for City Council:**

**Committee:** PIES **Date:** 10/21/2024

**Committee Agenda type:** Discussion

**Date Rec'd**

10/22/2024

**Clerk's File #**

RES 2024-0101

**Cross Ref #**

**Project #**

**Council Meeting Date:** 11/04/2024

**Submitting Dept**

CITY COUNCIL

**Bid #**

**Contact Name/Phone**

JACKSON DEESE 6718

**Requisition #**

**Contact E-Mail**

JDEESE@SPOKANECITY.ORG

**Agenda Item Type**

Resolutions

**Council Sponsor(s)**

ZZAPPONE MCATHCART BWILKERSON

**Agenda Item Name**

0320 - RESOLUTION REQUESTING TRAFFIC CALMING MEASURES ON POST

**Agenda Wording**

A Resolution relating to the Traffic Calming Fund and requesting the mayor use traffic calming funds to install a stop sign and speed tables on the Post Street Bridge.

**Summary (Background)**

A STOP SIGN ON THE SOUTH SIDE OF THE POST STREET BRIDGE AND SPEED TABLES IN THE AUTOMOBILE LANE ARE REQUESTED AS TRAFFIC CALMING INTERVENTIONS THAT WOULD BE APPROPRIATE TO FURTHER LIMIT AUTOMOBILE SPEEDING ON THE POST STREET BRIDGE.

Lease? NO Grant related? NO Public Works? NO

**Fiscal Impact**

Approved in Current Year Budget? YES

Total Cost \$ 5,000-10,000

Current Year Cost \$ 5,000-10,000

Subsequent Year(s) Cost \$ ~5%

**Narrative**

**Amount**

**Budget Account**

Expense \$ 5,000-10,000

# traffic calming fund

Select \$

#

Select \$

#

Select \$

#

\$

#

\$

#



**Continuation of Wording, Summary, Approvals, and Distribution**

**Agenda Wording**

**Summary (Background)**

**Approvals**

**Dept Head**

**Division Director**

**Accounting Manager**

ORLOB, KIMBERLY

**Legal**

SCHOEDEL, ELIZABETH

**For the Mayor**

**Additional Approvals**

**Distribution List**

[nzollinger@spokanecity.org](mailto:nzollinger@spokanecity.org)

## Committee Agenda Sheet

### Public Infrastructure, Environment & Sustainability Committee

<b>Committee Date</b>	10/21/24
<b>Submitting Department</b>	COUNCIL
<b>Contact Name</b>	JACKSON DEESE
<b>Contact Email &amp; Phone</b>	JDEESE@SPOKANECITY.ORG
<b>Council Sponsor(s)</b>	ZZAPPONE
<b>Select Agenda Item Type</b>	<input type="checkbox"/> Consent <input checked="" type="checkbox"/> Discussion    Time Requested: 10 min
<b>Agenda Item Name</b>	RESOLUTION REQUESTING THE ADMINISTRATION USE TRAFFIC CALMING DOLLARS TO INSTALL A STOP SIGN AND SPEED TABLES ON THE POST STREET BRIDGE.
<b>Proposed Council Action</b>	<input checked="" type="checkbox"/> Approval to proceed to Legislative Agenda <input type="checkbox"/> Information Only
<b>Summary (Background)</b>  *use the Fiscal Impact box below for relevant financial information	A STOP SIGN ON THE SOUTH SIDE OF THE POST STREET BRIDGE AND SPEED TABLES IN THE AUTOMOBILE LANE ARE REQUESTED AS TRAFFIC CALMING INTERVENTIONS THAT WOULD BE APPROPRIATE TO FURTHER LIMIT AUTOMOBILE SPEEDING ON THE POST STREET BRIDGE.
<p><b>Fiscal Impact</b></p> <p><b>Approved in current year budget?</b>    <input checked="" type="checkbox"/> Yes    <input type="checkbox"/> No    <input type="checkbox"/> N/A</p> <p>Total Cost: <u>\$5,000 – \$10,000</u></p> <p>    Current year cost: \$5,000 – \$10,000</p> <p>    Subsequent year(s) cost: Regular maintenance (~5% of project cost)</p> <p><b>Narrative:</b> <u>Despite the narrow, one-way lane on the Post Street Bridge, guided by the planters, the straight-away design of the traffic lane contributes to higher than needed speeds that pose a threat to the pedestrian and bicyclist traffic that is more heavily focused as part of the overall purpose of the bridge. This resolution requests additional traffic calming interventions to promote safer, slower vehicular traffic on the bridge.</u></p> <p><b>Funding Source</b>    <input checked="" type="checkbox"/> One-time    <input type="checkbox"/> Recurring    <input type="checkbox"/> N/A</p> <p>Specify funding source: Program revenue</p> <p>Is this funding source sustainable for future years, months, etc? <b>Yes, minor maintenance costs as required.</b></p> <p><b>Expense Occurrence</b>    <input type="checkbox"/> One-time    <input checked="" type="checkbox"/> Recurring    <input type="checkbox"/> N/A</p> <p>Other budget impacts: (revenue generating, match requirements, etc.)</p>	
<p><b>Operations Impacts</b> (If N/A, please give a brief description as to why)</p> <ul style="list-style-type: none"> <li>• What impacts would the proposal have on historically excluded communities?</li> </ul> <p><b>No impacts on historically excluded communities.</b></p>	

- How will data be collected, analyzed, and reported concerning the effect of the program/policy by racial, ethnic, gender identity, national origin, income level, disability, sexual orientation, or other existing disparities?

**N/A**

- How will data be collected regarding the effectiveness of this program, policy, or product to ensure it is the right solution?

**Noticing a reduction in average speeds on the Post Street Bridge.**

- Describe how this proposal aligns with current City Policies, including the Comprehensive Plan, Sustainability Action Plan, Capital Improvement Program, Neighborhood Master Plans, Council Resolutions, and others?

**Follows Council policy in promoting safer streets and encouraging modes of transportation other than driving, particularly in the Downtown core.**

**Council Subcommittee Review**

- Please provide a summary of council subcommittee review. If not reviewed by a council subcommittee, please explain why not.

**Not reviewed by a subcommittee. Potential to be reviewed by Transportation Commission when ready.**

**RESOLUTION NO. 2024-0101**

A Resolution relating to the Traffic Calming Fund and requesting the mayor use traffic calming funds to install a stop sign and speed tables on the Post Street Bridge.

**WHEREAS**, there is an urgent need to make our streets safer; and

**WHEREAS**, the Post Street Bridge was intentionally designed with greater opportunities for pedestrian and bicycle travel in Spokane; and

**WHEREAS**, despite the pedestrian-friendly design of the newly renovated bridge, drivers still use excessive speeds and Council is interested in slowing down automobile traffic on the Post Street Bridge; and

**WHEREAS**, on August 26, 2019, the City Council enacted ordinance C35809, establishing new Section 07.08.148 in the Spokane Municipal Code to create the “Traffic Calming Fund” into which funds from automated traffic safety cameras infractions were deposited; and

**WHEREAS**, under SMC 07.08.148, funds in the Traffic Calming Fund as to be used to pay for “traffic calming measures” and such operational expenses associated with the automated safety camera program; and

**WHEREAS**, in 2024, the Washington Legislature enacted Engrossed Substitute Senate Bill 2384, which, among other provisions, allows revenues generated from automated safety-camera programs to be devoted to a broader array of traffic calming measures, including stops signs, adaptive design, and speed tables; and

**WHEREAS**, the City Council historically has directed the allocation of funds generated from automated traffic safety cameras; and

**WHEREAS**, the Traffic Calming Fund is replenishing funds that were allocated for projects in 2025 with \$1 million in grants secured by Integrated Capital Management in 2024.

**NOW, THEREFORE, BE IT RESOLVED**, that the Spokane City Council requests that the Administration implement and, if necessary, purchase, a stop sign on the South side of the Post Street Bridge and speed tables along the automobile traffic lane of the Post Street Bridge.

**BE IT FURTHER RESOLVED**, that the City Council authorizes the use of funds from the Traffic Calming Fund to complete this request.

ADOPTED by the City Council this \_\_\_\_ day of \_\_\_\_\_, 2024.

---

City Clerk

Approved as to form:

---

Assistant City Attorney



**Agenda Sheet for City Council:**

**Committee:** PIES **Date:** 10/21/2024

**Committee Agenda type:** Consent

**Date Rec'd** 10/22/2024

**Clerk's File #** RES 2024-0102

**Cross Ref #** RES 2019-0018

**Project #**

**Council Meeting Date:** 11/04/2024

**Submitting Dept** INTEGRATED CAPITAL **Bid #**

**Contact Name/Phone** INGA NOTE 6331 **Requisition #**

**Contact E-Mail** INOTE@SPOKANECITY.ORG

**Agenda Item Type** Resolutions

**Council Sponsor(s)** BWILKERSON JBINGLE KKLITZKE

**Agenda Item Name** 4250-RESOLUTION - SCHOOL ZONE SPEED LIMIT SCHEDULE REVISIONS

**Agenda Wording**

A proposed resolution adjusting the school zone speed limit boundaries at the Sacajawea Middle School zone and the combined Yasuhara Middle and Logan Elementary School zone.

**Summary (Background)**

Two adjustments are needed to school speed limit boundaries. One at Sacajawea Middle School on Grand Boulevard, the school crosswalk has been relocated from 33rd to 32nd and the "20 When Flashing" units have been moved appropriately. The second location is at the combined Yasuhara Middle and Logan Elementary School zone where the "20 When Flashing" units couldn't be installed at the originally identified locations. The School Zone Speed Limit Schedule needs to match the new locations.

Lease? NO Grant related? NO Public Works? NO

**Fiscal Impact**

Approved in Current Year Budget? N/A

Total Cost \$

Current Year Cost \$

Subsequent Year(s) Cost \$

**Narrative**

<b>Amount</b>	<b>Budget Account</b>
Select \$	#
Select \$	#
Select \$	#
Select \$	#
\$	#
\$	#





**Continuation of Wording, Summary, Approvals, and Distribution**

**Agenda Wording**

**Summary (Background)**

**Approvals**

<b><u>Dept Head</u></b>	DAVIS, MARCIA
<b><u>Division Director</u></b>	FEIST, MARLENE
<b><u>Accounting Manager</u></b>	ORLOB, KIMBERLY
<b><u>Legal</u></b>	SCHOEDEL, ELIZABETH
<b><u>For the Mayor</u></b>	PICCOLO, MIKE

**Additional Approvals**

**Distribution List**

	jrhall@spokanecity.org
tax&licenses@spokanecity.org	icmaccounting@spokanecity.org
inote@spokanecity.org	eraea@spokanecity.org
ceharris@spokanecity.org	mdavis@spokanecity.org

## Committee Agenda Sheet

### Public Infrastructure, Environment & Sustainability Committee

<b>Committee Date</b>	10/21/24
<b>Submitting Department</b>	ICM, Streets
<b>Contact Name</b>	Inga Note
<b>Contact Email &amp; Phone</b>	<a href="mailto:inote@spokanecity.org">inote@spokanecity.org</a> , 625-6331
<b>Council Sponsor(s)</b>	CP Wilkerson, CM Bingle, CM Klitzke
<b>Select Agenda Item Type</b>	<input checked="" type="checkbox"/> Consent <input type="checkbox"/> Discussion    Time Requested:
<b>Agenda Item Name</b>	School Speed Limit Revisions
<b>Proposed Council Action</b>	<input checked="" type="checkbox"/> Approval to proceed to Legislative Agenda <input type="checkbox"/> Information Only
<b>Summary (Background)</b>	<p>Two adjustments are needed to school speed limit boundaries. One at Sacajawea Middle School on Grand Boulevard as the school crosswalk has been relocated from 33<sup>rd</sup> to 32<sup>nd</sup> and the 20 When Flashing units have been moved appropriately.</p> <p>The second location is at the combined Yasuhara Middle/Logan Elementary School zone where the 20 When Flashing units couldn't be installed at the originally identified locations. The School Zone Speed Limit Schedule needs to be updated to match the new flashing beacon locations.</p>
<p><b>Fiscal Impact</b></p> <p><b>Approved in current year budget?</b>    <input type="checkbox"/> Yes    <input type="checkbox"/> No    <input checked="" type="checkbox"/> N/A</p> <p>Total Cost: <u>\$0</u></p> <p>Current year cost:</p> <p>Subsequent year(s) cost:</p> <p><b>Narrative:</b> <u>This is updating the code to match the locations of the 20 mph zones in the field.</u></p> <p><b>Funding Source</b>    <input type="checkbox"/> One-time    <input type="checkbox"/> Recurring    <input checked="" type="checkbox"/> N/A</p> <p>Specify funding source: Select Funding Source*</p> <p>Is this funding source sustainable for future years, months, etc? <a href="#">Click or tap here to enter text.</a></p> <p><b>Expense Occurrence</b>    <input type="checkbox"/> One-time    <input type="checkbox"/> Recurring    <input checked="" type="checkbox"/> N/A</p> <p>Other budget impacts: (revenue generating, match requirements, etc.)</p>	
<p><b>Operations Impacts (If N/A, please give a brief description as to why)</b></p> <ul style="list-style-type: none"> <li>What impacts would the proposal have on historically excluded communities?</li> </ul> <p>Public works services and projects are designed to serve all citizens and businesses. We strive to offer a consistent level of service to all, to distribute public investment throughout the community and to respond to gaps in services identified in various City plans.</p>	

- How will data be collected, analyzed, and reported concerning the effect of the program/policy by racial, ethnic, gender identity, national origin, income level, disability, sexual orientation, or other existing disparities?

N/A

- How will data be collected regarding the effectiveness of this program, policy, or product to ensure it is the right solution?

Public Works follows the City's established procurement and public works bidding regulations and policies to bring items forward, and then uses contract management best practices to ensure desired outcomes and regulatory compliance. Staff has already coordinated with Spokane Public Schools.

- Describe how this proposal aligns with current City Policies, including the Comprehensive Plan, Sustainability Action Plan, Capital Improvement Program, Neighborhood Master Plans, Council Resolutions, and others?

This work is consistent with annual budget strategies to limit costs and approved projects in the 6-year CIP.

#### **Council Subcommittee Review**

- Please provide a summary of council subcommittee review. If not reviewed by a council subcommittee, please explain why not.

N/A

**RESOLUTION No. 2024-0102**

A RESOLUTION updating the City of Spokane's "School Zone Speed Limit Schedule" Resolution which was adopted on October 25, 2021.

WHEREAS, the Spokane City Council adopted the revised "School Zone Speed Limit Schedule" through Resolution 2021-0086 on October 25, 2021; and

WHEREAS, the Speed Zones in Exhibit "A" to the above referenced Resolution required modification around Sacajawea Middle School and Denny Yasuhara Middle School; and

WHEREAS, Exhibit "A" should be updated to read as follows:

**SACAJAWEA MIDDLE SCHOOL**

**GRAND BLVD** from 100 feet north of 31st Avenue to 68 feet south of 33rd Avenue.  
**LAMONTE STREET** from 160 feet north of 31st Avenue to 33rd Avenue.;

**DENNY YASUHARA MIDDLE SCHOOL**

**MARIETTA AVENUE** from 310 feet west of Morton Street to Perry Street.  
**PERRY STREET** from 229 feet south of North Foothills Drive to 57 feet south of Carlisle Avenue.

**LOGAN ELEMENTARY**

**HAMILTON STREET** from 266 feet north of Baldwin Avenue to 16 feet north of Carlisle Avenue.  
**NEVADA STREET** from Carlisle Avenue to 167 feet north of Carlisle Avenue.  
**COLUMBUS STREET** from 150 feet north of Illinois Avenue to 150 feet north of Carlisle Avenue.  
**CARLISLE AVENUE** from 165 feet east of Hamilton Street to 150 feet east of Columbus Street.  
**MONTGOMERY AVENUE** from 55 feet east of Hamilton Street to 310 feet east of Columbus Street.  
**ILLINOIS AVENUE** from 38 feet east of Cincinnati Street to 495 feet east of Columbus Street.  
**PERRY STREET** from 229 feet south of North Foothills Drive to 57 feet south of Carlisle Avenue.

and

WHEREAS, the Street Department in cooperation with Spokane Public Schools will make the necessary changes to signing prior to student use of each school; and

**NOW, THEREFORE BE IT RESOLVED**, by the City Council of Spokane hereby approves and adopts the “School Zone Speed Limit Schedule” attached to this Resolution and identified as **Exhibit A**.

ADOPTED by the City Council \_\_\_\_\_, 2024.

\_\_\_\_\_  
City Clerk

Approved as to Form:

\_\_\_\_\_  
Assistant City Attorney

# Exhibit A

## SCHOOL ZONE SPEED LIMIT SCHEDULE

### School Speed Zones

#### **SCHOOL SPEED ZONES**

The following road sections have been designated as school zones. The maximum speed allowable on the said road sections shall be 20 miles per hour as designated with any of the signage options pursuant to Washington Administrative Code section 392-151-035 as adopted or amended. The Council may establish any changes to speed limits or school speed zones by resolution.

#### **TWENTY MILES PER HOUR:**

##### **ADAMS ELEMENTARY**

**RAY STREET** from 75 feet south of 34th Avenue to 19 feet south of 36th Avenue.

**FREYA STREET** from 38 feet south of 34th Avenue to 75 feet south of 36th Avenue.

**36th AVENUE** from 436 feet east of Regal Street to 210 feet east of Fiske Street.

##### **ALL-SAINTS ELEMENTARY**

**FREYA STREET** from 74 feet south of 17th Avenue to 272 feet south of 18th Avenue.

**18th AVENUE** from 178 feet east of Ralph Street to 353 feet east of Thor Street.

##### **ALL-SAINTS MIDDLE SCHOOL**

**PERRY STREET** from 132 feet south of 32nd Avenue to 219 feet south of 34th Avenue.

##### **ARLINGTON ELEMENTARY**

**SMITH STREET** from 360 feet north of Francis Avenue to 786 feet north of Francis Avenue.

**FRANCIS AVENUE** from 155 feet east of Altamont Street to 65 feet east of Smith Street.

##### **AUDUBON ELEMENTARY**

**BELT STREET** from 195 feet north of Montgomery Avenue to 100 feet north of Jackson Avenue.

**CANNON STREET** from Jackson Avenue to 172 feet north of Jackson Avenue.

**ASH STREET** from 17 feet north of Chelan Avenue to 93 feet north of Northwest Blvd.

**MAPLE STREET** from 330 feet north of Carlisle Ave to 41 feet north of Chelan Avenue.

**NORTHWEST BLVD** from 32 feet west of Jackson Avenue to 105 feet west of York Avenue.

**YORK AVENUE** from 163 feet west of Walnut Street to 270 feet west of Maple Street.

**CARLISLE AVENUE** from 317 feet west of Oak Street to 365 feet west of Cannon Street.

**BALBOA ELEMENTARY**

**ELMHURST STREET** from 149 feet north of Houston Avenue to Holyoke Avenue.

**AUDUBON STREET** from Holyoke Avenue to 488 feet north of Holyoke Avenue.

**HOLYOKE AVENUE** from 59 feet west of A Street to 168 feet west of Elmhurst Street.

**BEMISS ELEMENTARY**

**CRESTLINE STREET** from 29 feet north of Bridgeport Avenue to 285 feet north of Courtland Avenue.

**STONE STREET** from 231 feet north of Liberty Avenue to 245 feet north of Courtland Avenue.

**BRIDGEPORT AVENUE** from 55 feet east of Lee Street to 18 feet east of Altamont Street.

**EUCLID AVENUE** from 48 feet east of Altamont Street to 222 feet east of Cook Street.

**BROWNE ELEMENTARY**

**UPPER DRISCOLL BLVD** from Queen Place to 180 feet north of Queen Place.

**DRISCOLL BLVD** from 173 feet north of Broad Place to 446 feet north of Queen Place.

**QUEEN PLACE** from 162 feet west of Greenwood Blvd to Upper Driscoll Blvd.

**TEC @ BRYANT ELEMENTARY**

**ASH STREET** from Broadway Avenue to 152 feet north of Mallon Avenue.

**CATALDO ELEMENTARY**

**BERNARD STREET** from 283 feet south of 16th Avenue to 86 feet south of 19th Avenue.

**18th AVENUE** from 235 feet west of Bernard Street to 438 feet west of Stevens Street.

**CHASE MIDDLE SCHOOL**

**37<sup>th</sup> AVENUE** from 32 feet east of Dearborn Street to 4 feet east of Lloyd Street.

**COOPER ELEMENTARY**

**THOR STREET** from 285 feet north of Euclid Avenue to 274 feet north of Bridgeport Avenue.

**FREYA STREET** from 170 feet north of Cleveland Avenue to 270 feet north of Bridgeport Avenue.

**BRIDGEPORT AVENUE** from 10 feet east of Ralph Street to 361 feet east of Freya Street.

**EUCLID/FREDERICK AVENUE** from 325 feet east of Thor Street to 11 feet east of Sycamore Street.

**DENNY YASUHARA MIDDLE SCHOOL**

**MARIETTA AVENUE** from 310 feet west of Morton Street to Perry Street.

**PERRY STREET** from 229 feet south of North Foothills Drive to 57 feet south of Carlisle Avenue. This zone also used for *LOGAN ELEMENTARY*.

**FERRIS HIGH SCHOOL**

**REGAL STREET** from 38 feet north of 36th to 44 feet south of 39th Avenue.

**37th AVENUE** from 318 feet east of Mt Vernon Street to 100 feet west of Ray Street.

**FINCH ELEMENTARY**

**ALBERTA STREET** from 27 feet north of Kiernan Avenue to 238 feet north of Providence Avenue.

**DRISCOLL BLVD** from 341 feet north of Gordon Avenue to 141 feet north of Providence Avenue.

**MILTON STREET** from 178 feet north of Gordon Avenue to Kiernan Avenue.

**NORTHWEST BLVD** from 78 feet west of Euclid Avenue to 10 feet west of A Street.

**FRANKLIN ELEMENTARY**

**MT. VERNON STREET** from 10 feet south of 15th Avenue to 166 feet south of 17th Avenue.

**17th AVENUE** from 127 feet east of Cook Street to 302 feet east of Mt Vernon Street.

**GARFIELD ELEMENTARY**

**POST STREET** from 285 feet north of Shannon Avenue to 280 feet north of Mansfield Avenue.

**HOWARD STREET** from 260 feet north of Shannon Avenue to 25 feet north of Montgomery Avenue.

**WASHINGTON STREET** from 266 feet north of Augusta Avenue to 20 feet north of Shannon Avenue.

**WASHINGTON STREET** from 267 feet north of Shannon Ave to 16 feet north of Montgomery Avenue.

**CALISPEL STREET** from 150 feet north of Shannon Avenue to 200 feet north of Mansfield Avenue.

**NORMANDIE STREET** from Mansfield Avenue to 238 feet north of Mansfield Avenue.

**BUCKEYE AVENUE** from 20 feet west of Atlantic Street to 267 feet west of Normandie Street.

**MANSFIELD AVENUE** from 295 feet west of Division Street to 128 feet west of Washington Street.

**KNOX AVENUE** from 44 feet west of Atlantic Street to 128 feet west of Washington Street.

**INDIANA AVENUE** from 325 feet west of Normandie Street to 25 feet west of Stevens Street.

**GARRY MIDDLE SCHOOL**

**NEVADA STREET** from 265 feet north of Rowan Avenue to 262 feet north of Central Avenue.

**GLOVER MIDDLE SCHOOL**

**ALBERTA STREET** from 200 feet north of Lacrosse Avenue to 319 feet north of Heroy Avenue.

**BELT STREET** from 638 feet north of Walton Avenue to 120 feet north of Longfellow Avenue.

**GONZAGA PREPARATORY SCHOOL**

**PERRY STREET** from 300 feet north of Dalton Avenue (west) to Fairview Avenue.

**GRANT ELEMENTARY**

**IVORY STREET** from 114 feet south of Eighth Avenue to Ninth Avenue.

**NINTH AVENUE** from 402 feet east of Arthur Street to 216 feet east of Ivory Street.

**HAMBLEN ELEMENTARY**

**NAPA STREET** from 16 feet south of 40th Avenue to Thurston Avenue.

**MARTIN STREET** from Thurston Avenue to 175 feet south of Thurston Avenue.

**CRESTLINE STREET** from 127 feet south of Lee Avenue to 142 feet south of Thurston Avenue.

**37th AVENUE** from 267 feet east of Pittsburg Street to 400 feet east of Napa Street.

**THURSTON AVENUE** from 16 feet east of Napa Street to 20 feet east of Lee Street.



**HOLMES ELEMENTARY**

**LINDEKE STREET** from 178 feet north of Boone Avenue to 319 feet north of Sharp Avenue.  
**COCHRAN STREET** from 48 feet north of Boone Avenue to 327 feet north of Sharp Avenue.  
**SHARP AVENUE** from 381 feet west of Nettleton Street to 200 feet west of Lindeke Street.  
**BOONE AVENUE** from 271 feet west of Nettleton Street to 331 feet west of Lindeke Street.

**HUTTON ELEMENTARY**

**GRAND BLVD** from 16 feet south of 24th Avenue to 307 feet south of 25th Avenue.  
**GARFIELD ROAD** from Plateau Road to 242 feet south of 24th Avenue.  
**24th AVENUE** from Garfield Road to 201 feet east of Plateau Road.

**INDIAN TRAIL ELEMENTARY**

**SUTHERLIN STREET** from 28 feet north of Woodside Avenue to 246 feet north of Weile Avenue.  
**WEILE AVENUE** from 133 feet west of Winston Drive to 126 feet west of Sutherlin Street.  
**WOODSIDE AVENUE** from 208 feet west of Fleming Street to 106 feet west of Sutherlin Street.

**JEFFERSON ELEMENTARY**

**MANITO BLVD** from 104 feet south of 36th Avenue to 242 feet south of 37th Avenue.  
**GRAND BLVD** from 352 feet south of 35th Avenue to 215 feet south of 37th Avenue.  
**37th AVENUE** from 225 feet west of Manito Blvd to 215 feet east of Tekoa Street.  
**37th AVENUE** from 173 feet east of Lamonte Street to 200 feet east of Grand Blvd.

**LEWIS & CLARK HIGH SCHOOL**

**STEVENS STREET** from 63 feet south of Third Avenue to 312 feet south of Fifth Avenue.  
**WASHINGTON STREET** from 179 feet south of Third Avenue to 289 feet south of Fifth Avenue.

**LIDGERWOOD ELEMENTARY**

**LIDGERWOOD STREET** from 165 feet north of Sanson Avenue to 50 feet north of Nebraska Avenue.  
**ADDISON STREET** from 265 feet north of Sanson Avenue to 83 feet north of Nebraska Avenue.  
**ROWAN AVENUE** from 468 feet east of Mayfair Street to 240 feet east of Addison Street.

**LINCOLN HEIGHTS ELEMENTARY**

**THOR STREET** from 203 feet south of 21st Avenue to 158 feet south of 23rd Avenue.  
**FREYA STREET** from 42 feet south of 21st Avenue to 260 feet south of 22nd Avenue.  
**22nd AVENUE** from Thor Street to 118 feet east of Thor Street.  
**23rd AVENUE** from 400 feet east of Ray Street to 274 feet east of Thor Street.

**LOGAN ELEMENTARY**

**HAMILTON STREET** from 266 feet north of Baldwin Avenue to 16 feet north of Carlisle Avenue.  
**NEVADA STREET** from Carlisle Avenue to 167 feet north of Carlisle Avenue.  
**COLUMBUS STREET** from 150 feet north of Illinois Avenue to 150 feet north of Carlisle Avenue.  
**CARLISLE AVENUE** from 165 feet east of Hamilton Street to 150 feet east of Columbus Street.  
**MONTGOMERY AVENUE** from 55 feet east of Hamilton Street to 310 feet east of Columbus Street.

**ILLINOIS AVENUE** from 38 feet east of Cincinnati Street to 495 feet east of Columbus Street.  
**PERRY STREET** from 229 feet south of North Foothills Drive to 57 feet south of Carlisle Avenue. This zone also used for *DENNY YASUHARA MIDDLE SCHOOL*.

**LONGFELLOW ELEMENTARY**

**CINCINNATI STREET** from 135 feet north of Gordon Avenue to 106 feet north of Providence Avenue.  
**NEVADA STREET** from 85 feet north of Gordon Avenue to 123 feet north of Garland Avenue.  
**EMPIRE AVENUE** from 264 feet east of Cincinnati Street to 458 feet east of Nevada Street.  
**PROVIDENCE AVENUE** from 479 feet east of Standard Street to 311 feet east of Nevada Street.

**MADISON ELEMENTARY**

**WALL STREET** from 160 feet north of Everett Avenue to 12 feet north of Nebraska Avenue.  
**WHITEHOUSE STREET** from 553 feet north of Everett Avenue to 264 feet north of Nebraska Avenue.  
**NEBRASKA AVENUE** from 213 feet west of Normandie Street to 321 feet west of Whitehouse Street.  
**ROWAN AVENUE** from Whitehouse Street to 138 feet west of Whitehouse Street.  
**QUEEN AVENUE** from 312 feet west of Normandie Street to 300 feet west of Whitehouse Street.

**NORTH CENTRAL HIGH SCHOOL**

**HOWARD STREET** from 50 feet north of Maxwell Avenue to 92 feet south of Indiana Avenue.  
**MAXWELL AVENUE** from 473 feet west of Washington Street to 47 feet west of Wall Street.

**PAULINE FLETT MIDDLE SCHOOL**

**WELLESLEY AVENUE** from 400 feet east of Hartley to 300 feet east of Royal Court.

**PRIDE PREP CHARTER**

**SPRAGUE AVENUE** from 323 feet east of Hatch Street to 602 feet east of Scott Street.

**REGAL ELEMENTARY, SHAW MIDDLE SCHOOL, NEWTECH, ON-TRACK**

**CRESTLINE STREET** from 262 feet north of Rockwell Avenue to 265 feet north of Longfellow Avenue.  
**COOK STREET** from 927 feet north of Garland Avenue to 251 feet north of Rich Avenue.  
**LACEY STREET** from Rich Avenue to 283 feet north of Longfellow Avenue.  
**REGAL STREET** from 20 feet north of Rockwell Avenue to 28 feet north of Longfellow Avenue.  
**WELLESLEY AVENUE** from 262 feet east of Cook Street to 19 feet east of Nelson Street.  
**LONGFELLOW AVENUE** from 362 feet east of Cook Street to cul-de-sac.  
**RICH AVENUE** from 376 feet east of Stone Street to 268 feet east of Regal Street.  
**EMPIRE AVENUE** from 263 feet east of Stone Street to 294 feet east of Cook Street.

**RIDGEVIEW ELEMENTARY**

**ASH STREET** from 172 feet north of Joseph Avenue to 16 feet north of Rowan Avenue.  
**MAPLE STREET** from 80 feet north of Rowan Avenue to 136 feet north of Joseph Avenue.  
**CEDAR STREET** from 169 feet north of Rowan Avenue to 251 feet north of Nebraska Avenue.  
**JOSEPH AVENUE** from 195 feet west of Adams Street to 191 feet west of Walnut Street.  
**NEBRASKA AVENUE** from 120 feet west of Cedar Street to 117 feet west of Walnut Street.

**ROWAN AVENUE** from 174 feet west of Adams Street to 195 feet west of Ash Street.

**ROGERS HIGH SCHOOL**

**WELLESLEY AVENUE** from 320 feet east of Perry Street to 410 feet east of Pittsburg Street.

**ROOSEVELT ELEMENTARY**

**GROVE/BERNARD STREET** from 15 feet south of 13th Avenue to 50 feet south of 15th Avenue.

**GRAND BLVD** from 130 feet south of 13th Avenue to 259 feet south of 14th Avenue.

**14th AVENUE** from 49 feet west of Division Street to 290 feet west of Grove Street.

**15th AVENUE** from 396 feet west of Division Street to 1005 feet west of Division Street.

**SACAJAWEA MIDDLE SCHOOL**

**GRAND BLVD** from 100 feet north of 31st Avenue to 68 feet south of 33rd Avenue.

**LAMONTE STREET** from 160 north of 31<sup>st</sup> Avenue to 33<sup>rd</sup> Avenue

**SALK MIDDLE SCHOOL**

**ALBERTA STREET** from 110 feet north of Francis Avenue to 298 feet north of Holyoke Avenue.

**STONEWALL AVENUE** from 100 feet north of Francis Avenue to 123 feet north of Lyons Avenue.

**SHADLE PARK HIGH SCHOOL**

**ASH STREET** from 270 feet north of Princeton Avenue to 50 feet south of Longfellow Avenue.

**FRANCES SCOTT ELEMENTARY**

**THOR STREET** from 20 feet south of Fourth Avenue to 377 feet south of Fifth Avenue.

**FREYA STREET** from 15 feet south of Sixth Avenue to 156 feet south of Third Avenue.

**REBECCA STREET** from 283 feet south of Fifth Avenue to 65 feet south of Third Avenue.

**FOURTH AVENUE** from 396 feet east of Freya Street to 263 feet east of Rebecca Street.

**FIFTH AVENUE** from 10 feet east of Ferrall Street to 308 feet east of Rebecca Street.

**SHILOH HILLS ELEMENTARY**

**MAGNESIUM ROAD** from 63 feet east of Standard Street to 155 feet east of Dakota Street.

**STONEWALL AVENUE** from 254 feet east of Antietam Drive to Vicksburg.

**SPOKANE PUBLIC MONTESSORI**

**KNOX AVENUE** from 52 feet west of Adams Street to 235 feet west of Cedar Street.

**STEVENS ELEMENTARY**

**MADELIA STREET** from 20 feet north of Sharp Avenue to 290 feet north of Sinto Avenue.

**MAGNOLIA STREET** from 30 feet north of Sharp Avenue to 270 feet north of Sinto Avenue.

**NAPA STREET** from 35 feet north of Sharp Avenue to 255 feet north of Sinto Avenue.

**MISSION AVENUE** from 60 feet east of Madelia Street to 65 feet east of Napa Street.

**SINTO AVENUE** from 150 feet east of Helena Street to 204 feet east of Magnolia Street.

**ST. ALOYSIUS ELEMENTARY**

**MISSION AVENUE** from 60 feet east of Madelia Street to 65 feet east of Napa Street.

**WESTVIEW ELEMENTARY**

**MOORE STREET** from 519 feet north of Central Avenue to 375 feet north of Bismark Avenue.

**FOTHERINGHAM STREET** from 393 feet north of Central Avenue to 104 feet north of Decatur Avenue.

**DECATUR AVENUE** from 554 feet west of G Street to 92 feet west of Moore Street.

**BISMARK AVENUE** from 520 feet west of G Street to 125 feet west of Moore Street.

**WHITMAN ELEMENTARY**

**HELENA STREET** from 170 feet north of Crown Avenue to 112 feet north of Sanson Avenue.

**PITTSBURG STREET** from 197 feet north of Crown Avenue to 212 feet north of Sanson Avenue.

**ROWAN AVENUE** from 219 feet east of Perry Street to 313 feet east of Helena Street.

**WILLARD ELEMENTARY**

**MONROE STREET** from 20 feet north of Longfellow Avenue to 310 feet north of Heroy Avenue.

**WALL STREET** from 60 feet north of Rockwell Avenue to 30 feet north of Princeton Avenue.

**STEVENS STREET** from 163 feet north of Rockwell Avenue to 265 feet north of Heroy Avenue.

**LONGFELLOW AVENUE** from 105 feet west of Washington Street to 211 feet west of Howard Street.

**HEROY AVENUE** from 120 feet west of Washington Street to 121 feet west of Wall Street.

**WILSON ELEMENTARY**

**LINCOLN STREET** from 272 feet south of 23rd Avenue to 215 feet south of 26th Avenue.

**29th AVENUE** from 85 feet west of Post Street to 318 feet west of Lincoln Street.

**WOODRIDGE ELEMENTARY**

**INDIAN TRAIL ROAD** from 1,294 feet north of Barnes Road to 319 feet north of Shawnee Avenue.

**WOODRIDGE DRIVE** from 106 feet north of Lamar Avenue to 629 feet north of Shawnee Avenue.

**FARMDALE STREET** from 163 feet north of Belmont Drive to 185 feet north of Alpine Drive.

**SHAWNEE AVENUE** from 134 feet west of Sylvia Court to 187 feet west of Woodridge Drive.

**ALPINE DRIVE** from 210 feet west of Elderberry Avenue to Woodridge Drive.



**Agenda Sheet for City Council:**

**Committee:** PIES **Date:** 10/21/2024

**Committee Agenda type:** Discussion

**Date Rec'd** 10/22/2024

**Clerk's File #** RES 2024-0103

**Cross Ref #**

**Project #**

**Council Meeting Date:** 11/04/2024

<b>Submitting Dept</b>	PLANNING & ECONOMIC	<b>Bid #</b>	
------------------------	---------------------	--------------	--

<b>Contact Name/Phone</b>	SPENCER 6097	<b>Requisition #</b>	
---------------------------	--------------	----------------------	--

<b>Contact E-Mail</b>	SGARDNER@SPOKANECITY.ORG		
-----------------------	--------------------------	--	--

<b>Agenda Item Type</b>	Resolutions		
-------------------------	-------------	--	--

<b>Council Sponsor(s)</b>	BWILKERSON JBINGLE KKLITZKE		
---------------------------	-----------------------------	--	--

<b>Agenda Item Name</b>	0650 - 27 BY 2027 URBAN MOBILITY NETWORK RESOLUTION		
-------------------------	---	--	--

**Agenda Wording**

This Resolution proposes development of a connected 26-mile urban mobility network by the end of 2026. This network will connect low-volume, low-speed neighborhood streets to major city and regional pathways, using adaptive design strategies to make

**Summary (Background)**

This Resolution proposes development of a connected 27-mile urban mobility network by the end of 2027. This network will connect low-volume, low-speed neighborhood streets to major city and regional pathways, using adaptive design strategies to make intersection crossings safe for people walking, bicycling, or rolling with adaptive devices.

Lease? NO Grant related? NO Public Works? YES

**Fiscal Impact**

Approved in Current Year Budget? YES

Total Cost \$ TBD

Current Year Cost \$

Subsequent Year(s) Cost \$

**Narrative**

Revenue sources still under consideration, likely a combination sources, including wheelshare, Transportation Benefit District, Traffic Calming, and grant funding

**Amount**

**Budget Account**

Expense	\$ TBD	# TBD
Select	\$	#
Select	\$	#
Select	\$	#
	\$	#
	\$	#



## Continuation of Wording, Summary, Approvals, and Distribution

### Agenda Wording

### Summary (Background)

#### **Approvals**

##### Dept Head

BLACK, TIRRELL

##### Division Director

BLACK, TIRRELL

##### Accounting Manager

ORLOB, KIMBERLY

##### Legal

SCHOEDEL, ELIZABETH

##### For the Mayor

PICCOLO, MIKE

#### **Additional Approvals**

#### **Distribution List**

sgardner@spokanecity.org

mfeist@spokanecity.org

kpicanco@spokanecity.org

tkimbrell@spokanecity.org

jchurchill@spokanecity.org

ceharris@spokanecity.org

inote@spokanecity.org

smacdonald@spokanecity.org

akiehn@spokanecity.org

## Committee Agenda Sheet

### Public Infrastructure, Environment & Sustainability Committee

<b>Submitting Department</b>	Planning & Economic Development Services
<b>Contact Name</b>	Spencer Gardner
<b>Contact Email &amp; Phone</b>	<a href="mailto:sgardner@spokanecity.org">sgardner@spokanecity.org</a> ; 509-625-6097
<b>Council Sponsor(s)</b>	Klitzke, Dillon
<b>Select Agenda Item Type</b>	<input type="checkbox"/> Consent <input checked="" type="checkbox"/> Discussion    Time Requested: 10 minutes
<b>Agenda Item Name</b>	27 by 2027 Urban Mobility Network Resolution
<b>Summary (Background)</b>  *use the Fiscal Impact box below for relevant financial information	<p>This Resolution proposes development of a connected 27-mile urban mobility network by the end of 2027. This network will connect low-volume, low-speed neighborhood (local access) streets to major city and regional pathways, using adaptive design strategies. The network will also use some permanent infrastructure and enhanced crossing devices, such as Ped Hybrid Beacons and Rectangular Rapid Flashing Beacons to make intersection crossings safe for people walking, bicycling, or rolling with adaptive devices.</p> <p>The resolution also reiterates Council's support for the Locally-Preferred Alternative for the Division Street Bus Rapid Transit project, which would integrate into parallel routes created by the proposed 27 by 2027 network for providing comfortable access via bicycle through the corridor.</p>
<b>Proposed Council Action</b>	Approval
<p><b>Fiscal Impact</b>            Total Cost: \$TBD.            Approved in current year budget?    <input checked="" type="checkbox"/> Yes    <input type="checkbox"/> No    <input type="checkbox"/> N/A</p> <p>Funding Source    <input checked="" type="checkbox"/> One-time    <input type="checkbox"/> Recurring            Specify funding source: Undetermined, likely a combination sources, including wheelshare, Transportation Benefit District, Traffic Calming, and grant funding</p> <p>Expense Occurrence    <input checked="" type="checkbox"/> One-time    <input type="checkbox"/> Recurring</p> <p>Other budget impacts: (revenue generating, match requirements, etc.)</p>	
<b>Operations Impacts (If N/A, please give a brief description as to why)</b>	
<p>What impacts would the proposal have on historically excluded communities?</p> <p>The infrastructure investments installed through this project will support improved accessibility for residents in historically underserved neighborhoods including Northeast Spokane, West Central, East Central, South Logan and neighborhoods throughout Spokane. Through quick-build public right-of-way improvements, the project will connect walking, bicycling and pathway networks, enhancing arterial crossings and intersection treatments throughout Spokane, closing gaps in walking and bike facilities that currently create barriers. This project will connect residents with parks, amenities, schools, commercial areas and services.</p>	

How will data be collected, analyzed, and reported concerning the effect of the program/policy by racial, ethnic, gender identity, national origin, income level, disability, sexual orientation, or other existing disparities?

This project will monitor effectiveness through traffic counts, speed measurements, and direct feedback from neighborhood residents through mapping exercises, surveys and community meetings.

How will data be collected regarding the effectiveness of this program, policy or product to ensure it is the right solution?

This project will include multiple rounds of public engagement consisting of questionnaires, surveys, and online mapping activities, as well as public meetings and presentations, allowing direct feedback and rapid adjustment of adaptive design installations. Feedback obtained through these efforts will inform adjustments to installations and future installations. Subsequent phases of installations will use the same data collection methods to determine changes to travel patterns, safety and community sentiment as compared to baseline conditions.

Describe how this proposal aligns with current City Policies, including the Comprehensive Plan, Sustainability Action Plan, Capital Improvement Program, Neighborhood Master Plans, Council Resolutions, and others?

**Chapter 4, Transportation:**

- TR 2: Transportation Supporting Land Use
- TR 5: Active Transportation
- TR 6: Commercial Center Access
- TR 7: Neighborhood Access
- TR 9: Promote Economic Opportunity

This project aligns with previous studies and plans conducted by the City of Spokane, and the Spokane Transit Authority that propose investments in public infrastructure that improves accessibility and safe travel for all neighborhood residents.



## RESOLUTION NO. 2024-0103

This “27 by 2027” Resolution proposes development of a connected 27-mile urban mobility network by the end of 2027. This network will connect low-volume, low-speed neighborhood (local access) streets to major city and regional pathways, using adaptive design strategies. The network will also use some permanent infrastructure and enhanced crossing devices, such as Ped Hybrid Beacons and Rectangular Rapid Flashing Beacons to make intersection crossings safe for people walking, bicycling, or rolling with adaptive devices.

**WHEREAS**, serious and fatal crashes are on the rise in the City of Spokane; and

**WHEREAS**, data from the Spokane Regional Transportation Council (SRTC) indicates that crashes involving a person walking account for only 4% of all crashes in the City of Spokane, but account for 40% of fatal crashes and 30% of crashes with serious injuries; and

**WHEREAS**, people walking are twice as likely to be killed in a collision when a vehicle is traveling 30 miles per hour compared to 20 miles per hour; and

**WHEREAS**, since 2018, 23% of fatal and serious crashes in Spokane County were caused by a speeding driver; and

**WHEREAS**, the Spokane City Council adopted Ordinance C35768 in 2019 recognizing and codifying the foundational City of Spokane Comprehensive Plan Transportation approach of pedestrian safety and service as the City of Spokane’s highest transportation priority; and

**WHEREAS**, the Spokane City Council adopted a Complete Streets Program in 2011 with the purpose of accommodating all users in the construction of all City of Spokane transportation projects; and

**WHEREAS**, the Spokane City Council passed Resolution No. 2022-0107 adopting the City of Spokane’s Local Road Safety Risk-Based Analysis as the City’s Vision Zero Safety Action Plan toward eliminating fatalities and severe injuries as a result of crashes on City streets; and

**WHEREAS**, the City of Spokane was awarded \$9.6 million from the U.S. Department of Transportation based on the Vision Zero Safety Action Plan to improve safety along arterials where 85 percent of fatal and serious crashes occur involving people walking and bicycling; and

**WHEREAS**, the City of Spokane added \$2.4 million to the \$9.6 million federal award to implement the Spokane Safe Streets for All program of projects including crosswalk improvements, ADA ramps, signal adjustments, bike lanes, shared-use pathways, and other safety and mobility projects; and

**WHEREAS**, the City of Spokane supported the passage of HB 2384 authorizing the expansion of traffic safety cameras to improve traffic safety in city streets, state routes, and in work zones; and

**WHEREAS**, adaptive design strategies offer a low-cost method of street design that use temporary traffic-calming measures, resulting in rapid installation of safety improvements to test street changes before executing permanent projects; and

**WHEREAS**, on October 24, 2022, Spokane City Council passed Resolution No. 2022-0092 accepting the DivisionConnects study as a declaration of the City’s desired future transportation and land use conditions within the Division Street Corridor; and

**WHEREAS**, there are major arterial roads in the City of Spokane, such as Division Street, where a parallel route on a lower-traffic street is generally a more cost-effective and efficient way to provide for travel by bicycle compared to a bicycle facility on the major arterial; and

**WHEREAS**, some major arterial roads, such as Division Street, lack the necessary right-of-way to safely and efficiently prioritize people riding transit, walking, or biking equally without negatively impacting congestion, safety, and multi-modal uses on other transportation corridors in the City’s transportation network; and

**WHEREAS**, the Spokane City Council adopted Resolution No. 2024-0053 on June 24, 2024 endorsing the use of adaptive design strategies to accelerate safety improvements in the urban mobility network; and

**WHEREAS**, the Brown Administration issued Executive Order EO 2024-0007 on July 3, 2024, which, among other things, directed staff to carry out adaptive design and street operation changes for the purpose of improving street safety conditions for all users of the urban mobility network.

**NOW, THEREFORE, BE IT RESOLVED** the City of Council of the City of Spokane formally endorses establishing a branded, legible, and connected 27-mile urban mobility network by the end of 2027, using adaptive design strategies and strategic permanent infrastructure to calm traffic on neighborhood streets and create a safe, continuous, and cost-effective network for people walking, bicycling, accessing transit, and rolling with adaptive mobility devices.

**BE IT FURTHER RESOLVED** that the City Council of the City of Spokane reiterates its support for the Locally-Preferred Alternative for the Division Street Bus Rapid Transit line, including the planned “business access and transit” (BAT) lanes, and recognizes that facilities for people on bikes are more appropriately located on parallel routes through the Division Street corridor, except where identified within the Locally-Preferred Alternative for the Bus Rapid Transit line.

ADOPTED by the City Council \_\_\_\_\_, 2024.

\_\_\_\_\_  
City Clerk

Approved as to Form:

\_\_\_\_\_  
Assistant City Attorney



# 27 by 2027

## Urban Mobility Network

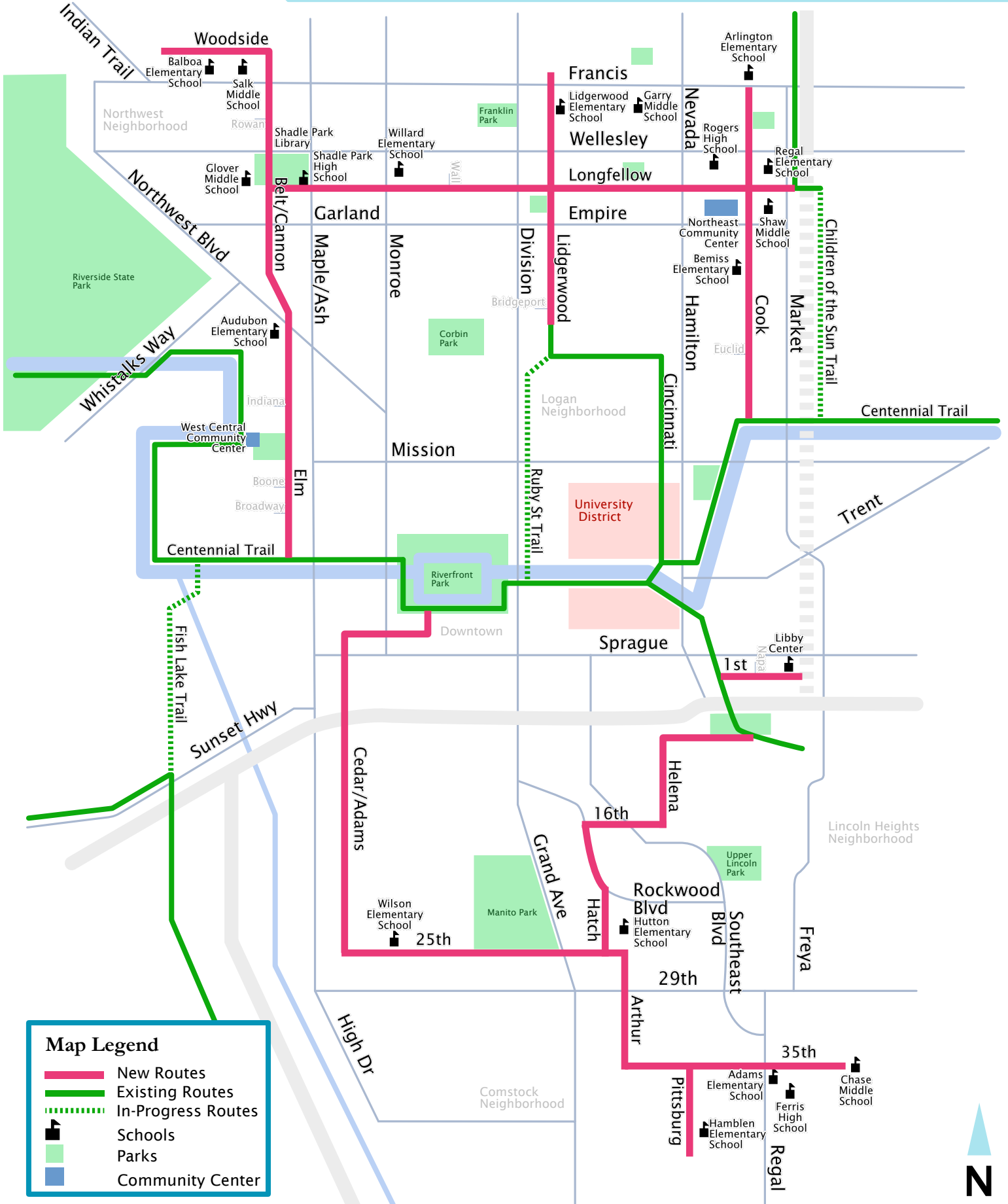

**Map Legend**

- New Routes
- Existing Routes
- ⋯ In-Progress Routes
- Schools
- Parks
- Community Center



**Agenda Sheet for City Council:****Committee:** PIES **Date:** 10/21/2024**Committee Agenda type:** Consent**Date Rec'd**

10/22/2024

**Clerk's File #**

RES 2024-0104

**Cross Ref #****Project #****Council Meeting Date:** 11/04/2024**Submitting Dept**

WASTEWATER MANAGEMENT

**Bid #****Contact Name/Phone**

KYLE 625-4647

**Requisition #**

VALUE BLANKET

**Contact E-Mail**

KARRINGTON@SPOKANECITY.ORG

**Agenda Item Type**

Resolutions

**Council Sponsor(s)**

BWILKERSON JBINGLE KKLITZKE

**Agenda Item Name**

4320 RESOLUTION WITH WHITNEY EQUIPMENT COMPANY, INC. FOR FLYGT

**Agenda Wording**

Resolution to authorize sole source procurement and authorizing its purchase from Whitney Equipment Company, Inc. for Flygt products. This is for a 5-year value blanket from October 31, 2024 to November 1, 2029 total cost is \$500,000.00.

**Summary (Background)**

RPWRF uses Flygt products to pump, mix and deliver chemicals to critical systems. These pumps and mixers are compatible with our existing equipment are used to ensure compliance with the Department of Ecology, EPA and Sierra Club requirements regarding the Clean Water Act, which is the basis of the City's NPDES Permit.

Lease? NO Grant related? NO Public Works? NO

**Fiscal Impact**

Approved in Current Year Budget? YES

Total Cost \$ 500,000.00

Current Year Cost \$

Subsequent Year(s) Cost \$

**Narrative**

This is for a 5-year value blanket total cost \$500,000.00

**Amount****Budget Account**

Expense \$ 500,000.00

# 4320.43240.35148.53210

Select \$

#

Select \$

#

Select \$

#

Select \$

#

Select \$

#



**Continuation of Wording, Summary, Approvals, and Distribution**

**Agenda Wording**

**Summary (Background)**

**Approvals**

**Dept Head**

GENNETT, RAYLENE

**Division Director**

FEIST, MARLENE

**Accounting Manager**

ALBIN-MOORE, ANGELA

**Legal**

SCHOEDEL, ELIZABETH

**For the Mayor**

PICCOLO, MIKE

**Additional Approvals**

**PURCHASING**

PRINCE, THEA

**Distribution List**

hbarnhart@spokanecity.org

kkeck@spokanecity.org

mmurray@spokanecity.org

Tax & Licenses

tlester@spokanecity.org

rpwrfaccounting@spokanecity.org

## Committee Agenda Sheet

### Public Infrastructure, Environment & Sustainability Committee

<b>Committee Date</b>	October 21, 2024
<b>Submitting Department</b>	Wastewater Management/RPWRP
<b>Contact Name</b>	Kyle Arrington
<b>Contact Email &amp; Phone</b>	<a href="mailto:karrington@spokanecity.org">karrington@spokanecity.org</a>
<b>Council Sponsor(s)</b>	CP Wilkerson, CM Bingle, CM Klitzke
<b>Select Agenda Item Type</b>	<input checked="" type="checkbox"/> Consent <input type="checkbox"/> Discussion    Time Requested:
<b>Agenda Item Name</b>	Resolution to authorize sole source procurement and authorizing its purchase from Whitney Equipment Company, Inc. for Flygt products
<b>Proposed Council Action</b>	<input checked="" type="checkbox"/> Approval to proceed to Legislative Agenda <input type="checkbox"/> Information Only
<b>Summary (Background)</b>	<p>RPWRP uses Flygt products to pump, mix and deliver chemicals to critical systems. These pumps and mixers are compatible with our existing equipment are used to ensure compliance with the Department of Ecology, EPA and Sierra Club requirements regarding the Clean Water Act, which is the basis of the City's NPDES Permit.</p> <p>This is a resolution to authorize sole source procurement for Flygt pumps, parts and supplies and authorizing the purchase from the only authorized dealer, Whitney Equipment Company, Inc.</p> <p>This is a five-year sole source resolution scheduled to begin on November 1<sup>st</sup>, 2024 and to end on October 31, 2029 at an estimated total cost of \$500,000.00.</p>
<p><b>Fiscal Impact</b></p> <p><b>Approved in current year budget?</b>    <input checked="" type="checkbox"/> Yes    <input type="checkbox"/> No    <input type="checkbox"/> N/A</p> <p>Total Cost: <u>\$500,000.00</u></p> <p>    Current year cost: Value Blanket over 5 years</p> <p>    Subsequent year(s) cost:</p> <p><b>Narrative:</b> <u>Parts and Supplies for 5-year value blanket</u></p> <p><b>Funding Source</b>            <input type="checkbox"/> One-time    <input checked="" type="checkbox"/> Recurring    <input type="checkbox"/> N/A</p> <p>Specify funding source: Program revenue</p> <p>Is this funding source sustainable for future years, months, etc? Yes</p> <p><b>Expense Occurrence</b>    <input type="checkbox"/> One-time    <input checked="" type="checkbox"/> Recurring    <input type="checkbox"/> N/A</p> <p>Other budget impacts: (revenue generating, match requirements, etc.)</p>	

**Operations Impacts** (If N/A, please give a brief description as to why)

- What impacts would the proposal have on historically excluded communities?  
Public works services and projects are designed to serve all citizens and businesses. We strive to offer a consistent level of service to all, to distribute public investment throughout the community and to respond to gaps in services identified in various City plans.
- How will data be collected, analyzed, and reported concerning the effect of the program/policy by racial, ethnic, gender identity, national origin, income level, disability, sexual orientation, or other existing disparities?  
N/A
- How will data be collected regarding the effectiveness of this program, policy, or product to ensure it is the right solution?  
Public Works follows the City's established procurement and public works bidding regulations and policies to bring items forward, and then uses contract management best practices to ensure desired outcomes and regulatory compliance.
- Describe how this proposal aligns with current City Policies, including the Comprehensive Plan, Sustainability Action Plan, Capital Improvement Program, Neighborhood Master Plans, Council Resolutions, and others?  
This work is consistent with annual budget strategies to limit costs and approved projects in the 6-year CIP.

**Council Subcommittee Review**

- Please provide a summary of council subcommittee review. If not reviewed by a council subcommittee, please explain why not.

SOLE-SOURCE RESOLUTION

A RESOLUTION declaring Whitney Equipment Company, Inc. (Woodinville, WA) a sole-source provider and authorizing the City to enter into a value blanket order for Flygt Products for a five (5) year period without public bidding.

WHEREAS, Flygt pumps are already existing throughout the facility and are used to pump, mix and deliver chemicals to critical systems; and

WHEREAS, these pumps and mixers are compatible with our existing equipment and are used to ensure compliance with the Department of Ecology, EPA and Sierra Club requirements regarding the Clean Water Act, which is the basis of the City’s NPDES Permit

WHEREAS, Whitney Equipment Company, Inc. is the exclusive factory authorized distributor of Flygt pumps and accessories for the Municipal and Industrial markets for the entire State of Washington; and

WHEREAS, It is to our benefit to maintain that standardization to streamline future maintenance operations; and

WHEREAS, if one of the Flygt pumps would fail, we could send millions of gallons of raw wastewater into the Spokane River; and

WHEREAS, the department anticipates the purchase of assorted universal pumps and accessories to exceed the 2024 public bid limit of \$50,000 for goods;

-- Now, Therefore,

BE IT RESOLVED by the City Council for the City of Spokane that it hereby declares the purchase of the Flygt pumps and accessories a sole-source purchase through Whitney Equipment Company, Inc.; and

BE IT FURTHER RESOLVED that the City Council authorizes a five (5) year value blanket order for the purchase of Flygt pumps and accessories, without public bidding.

ADOPTED BY THE CITY COUNCIL ON \_\_\_\_\_

\_\_\_\_\_  
City Clerk

Approved as to form:

\_\_\_\_\_  
Assistant City Attorney





## License Information:

[New search](#) [Back to results](#)

<b>Entity name:</b>	WHITNEY EQUIPMENT COMPANY, LLC
<b>Business name:</b>	WHITNEY EQUIPMENT CO., INC.
<b>Entity type:</b>	<a href="#">Limited Liability Company</a>
<b>UBI #:</b>	600-105-028
<b>Business ID:</b>	001
<b>Location ID:</b>	0001
<b>Location:</b>	Active
<b>Location address:</b>	16120 WOODINVILLE REDMOND RD NE STE 3 WOODINVILLE WA 98072-9090
<b>Mailing address:</b>	16120 WOODINVILLE REDMOND RD NE STE 3 WOODINVILLE WA 98072-9090
<b>Excise tax and reseller permit status:</b>	<a href="#">Click here</a>
<b>Secretary of State status:</b>	<a href="#">Click here</a>



## Endorsements

Endorsements held at this location	License #	Count	Details	Status	Expiration date	First issuance date
Bellingham General Business	039977			Active		Oct-06-2011
Bremerton General Business - Non-Resident	18986			Active	Jul-31-2025	Oct-24-1995
Cashmere General Business - Non-Resident				Active	Jul-31-2025	Aug-04-2022
Ferndale General Business - Non-Resident	124			Active	Jul-31-2025	Jun-24-2020
Franklin County General Business - Non-Resident	3982			Active	Jul-31-2025	Oct-17-2023
Ilwaco General Business - Non-Resident				Active	Jul-31-2025	Feb-01-2019
Issaquah General Business - Non-Resident				Active	Jul-31-2025	Oct-03-2022
Kelso General Business - Non-Resident	A040990			Active	Jul-31-2025	Jan-07-2014
Long Beach General Business - Non-Resident	1561			Active	Jul-31-2025	Jul-17-2024
Longview General Business - Non-Resident	878447			Active	Jul-31-2025	Nov-09-2020
Ocean Shores General Business - Non-Resident				Active	Jul-31-2025	Oct-26-2023



Endorsements held at this location	License #	Count	Details	Status	Expiration date	First issuance date
<a href="#">Richland General Business - Non-Resident</a>	F05			Active	Jul-31-2025	Aug-20-2018
<a href="#">Shelton General Business - Non-Resident</a>	0071910			Active	Jul-31-2025	Oct-28-2020
<a href="#">Spokane General Business - Non-Resident</a>	T12005928BUS			Active	Jul-31-2025	Oct-15-2012
<a href="#">Sultan General Business - Non-Resident</a>				Active	Jul-31-2025	Feb-25-2019

## Governing People May include governing people not registered with Secretary of State

Governing people	Title
DAU, JACOB	
MEENA, JOHN	
MORSE, JASON	
VANDE VUSSE, SCOTT	

## Registered Trade Names

Registered trade names	Status	First issued
WHITNEY EQUIPMENT CO., INC.	Active	Jul-20-2023

The Business Lookup information is updated nightly. Search date and time: 9/17/2024 2:08:21 PM



**Contact us**

How are we doing?

**Take our survey!**

Don't see what you expected?

**Check if your browser is supported**





**Agenda Sheet for City Council:**

**Committee:** PIES **Date:** 10/21/2024

**Committee Agenda type:** Consent

**Date Rec'd** 10/22/2024

**Clerk's File #** RES 2024-0105

**Cross Ref #**

**Project #**

**Council Meeting Date:** 11/04/2024

**Submitting Dept** WATER & HYDROELECTRIC SERVICES

**Bid #**

**Contact Name/Phone** LOREN SEARL 509-625-7821

**Requisition #**

**Contact E-Mail** LSEARL@SPOKANECITY.ORG

**Agenda Item Type** Resolutions

**Council Sponsor(s)** BWILKERSON JBINGLE KKLITZKE

**Agenda Item Name** 4100 PUBLIC RULE WATER UPDATE TO FEES AND COSTS

**Agenda Wording**

Update of the Public Rule and Procedure Fee Schedule to reflect current costs for 2025

**Summary (Background)**

Public Rule and Procedure Schedule - Rule 4100-20-02 was adopted November 2020 and updated January 2024. Since adoption, costs have increased necessitating an update of the Public Rule and Procedure Fee Schedule

Lease? NO Grant related? NO Public Works? NO

**Fiscal Impact**

Approved in Current Year Budget?

Total Cost \$

Current Year Cost \$

Subsequent Year(s) Cost \$

**Narrative**

**Amount**

**Budget Account**

Select \$ #

Select \$ #

Select \$ #

Select \$ #

\$ #

\$ #



# Continuation of Wording, Summary, Approvals, and Distribution

## Agenda Wording

## Summary (Background)

### **Approvals**

Dept Head

SEARL, LOREN

Division Director

FEIST, MARLENE

Accounting Manager

ALBIN-MOORE, ANGELA

Legal

SCHOEDEL, ELIZABETH

For the Mayor

PICCOLO, MIKE

### **Additional Approvals**

### **Distribution List**

rrpenaluna@spokanecity.org

nrussell@spokanecity.org

tlester@spokanecity.org

tprince@spokanecity.org

## Committee Agenda Sheet

### Public Infrastructure, Environment & Sustainability Committee

<b>Committee Date</b>	October 21 <sup>st</sup> 2024
<b>Submitting Department</b>	Water & Hydro Electric
<b>Contact Name</b>	Loren Searl
<b>Contact Email &amp; Phone</b>	625-7821
<b>Council Sponsor(s)</b>	Wilkerson, Bingle, Klitzke
<b>Select Agenda Item Type</b>	<input checked="" type="checkbox"/> Consent <input type="checkbox"/> Discussion    Time Requested:
<b>Agenda Item Name</b>	Public Rule Water Update to Fees and Costs
<b>Proposed Council Action</b>	<input checked="" type="checkbox"/> Approval to proceed to Legislative Agenda <input type="checkbox"/> Information Only
<b>Summary (Background)</b>	Public Rule and Procedure Schedule – Rule 4100-20-02 was adopted November 2020 and updated January 2024. Since adoption, costs have increased necessitating an update of the Public Rule and Procedure Fee Schedule to reflect current costs for 2025.
<p>*use the Fiscal Impact box below for relevant financial information</p>	<p><b>Fiscal Impact</b></p> <p><b>Approved in current year budget?</b>    <input type="checkbox"/> Yes    <input type="checkbox"/> No    <input checked="" type="checkbox"/> N/A</p> <p>Total Cost:</p> <p style="padding-left: 20px;">Current year cost:</p> <p style="padding-left: 20px;">Subsequent year(s) cost:</p> <p><b>Narrative:</b> Please provide financial due diligence review, as applicable, such as number and type of positions, grant match requirements, summary type details (personnel, maintenance and supplies, capital, revenue), impact on rates, fees, or future shared revenue</p> <p><b>Funding Source</b>    <input type="checkbox"/> One-time    <input type="checkbox"/> Recurring    <input checked="" type="checkbox"/> N/A</p> <p>Specify funding source: Select Funding Source*</p> <p><b>Expense Occurrence</b>    <input type="checkbox"/> One-time    <input type="checkbox"/> Recurring    <input checked="" type="checkbox"/> N/A</p> <p>Other budget impacts: (revenue generating, match requirements, etc.)</p>
<p><b>Operations Impacts (If N/A, please give a brief description as to why)</b></p> <ul style="list-style-type: none"> <li>• What impacts would the proposal have on historically excluded communities? Public works services and projects are designed to serve all citizens and businesses. We strive to offer a consistent level of service to all, to distribute public investment throughout the community and to respond to gaps in services identified in various City plans.</li>   <li>• How will data be collected, analyzed, and reported concerning the effect of the program/policy by racial, ethnic, gender identity, national origin, income level, disability, sexual orientation, or other existing disparities? N/A</li>   <li>• How will data be collected regarding the effectiveness of this program, policy, or product to ensure it is the right solution?</li> </ul>	

Public Works follows the City's established procurement and public works bidding regulations and policies to bring items forward, and then uses contract management best practices to ensure desired outcomes and regulatory compliance.

- Describe how this proposal aligns with current City Policies, including the Comprehensive Plan, Sustainability Action Plan, Capital Improvement Program, Neighborhood Master Plans, Council Resolutions, and others?

This work is consistent with annual budget strategies to limit costs and approved projects in the 6-year CIP.

#### **Council Subcommittee Review**

- Please provide a summary of council subcommittee review. If not reviewed by a council subcommittee, please explain why not.



**RESOLUTION**

A resolution regarding amendment to the City of Spokane Water and Hydroelectric Department – Fee & Cost Schedule.

WHEREAS, the City of Spokane Water and Hydroelectric Department Water Code is contained in Chapter 13.04 of the Spokane Municipal Code (SMC); and

WHEREAS, Chapter 13.04.030 of the SMC provides the General Provisions for Rates and Regulations to be established by Public Rule and

WHEREAS, the City has adopted the Public Rule and Procedure Regarding the Water and Hydroelectric Department Fee and Cost Schedule, periodically it is required to update the Fee and Cost Schedule; and

WHEREAS, the Water Department periodically reviews the Fee and Cost Schedule to accommodate the actual costs of administration and equipment of the Water and Hydroelectric Department and find the Public Rule is in need of update; and

WHEREAS, the revised Water and Hydroelectric Department - Fee & Cost Schedule Public Rule is attached and available to members of the public as attached hereto as Attachment “A”.

-- NOW, THEREFORE,

BE IT RESOLVED BY THE CITY COUNCIL OF THE CITY OF SPOKANE that the City Council hereby approves the amendment of the PUBLIC RULE AND PROCEDURE REGARDING THE WATER AND HYDROELECTRIC DEPARTMENT – FEE AND COST SCHEDULE, as contained in Attachment “A”.

ADOPTED by City Council this \_\_\_\_ day of November 2024.

\_\_\_\_\_  
City Clerk

Approved as to form:

\_\_\_\_\_  
Assistant City Attorney

CITY OF SPOKANE  
PUBLIC RULE  
DEPARTMENT POLICY AND PROCEDURE

CITY OF SPOKANE WATER AND HYDROELECTRIC DEPARTMENT PUBLIC RULE AND PROCEDURE	RULE 4100-20-02 LGL 2024-
TITLE: WATER AND HYDROELECTRIC DEPARTMENT – <b>UPDATE FEE SCHEDULE</b>	
EFFECTIVE DATE: JANUARY 1, 2025 REVISION DATE: <b>OCTOBER 21 , 2024</b>	

1.0 GENERAL

1.1 The City of Spokane Water and Hydroelectric Department established the following public rule, policy, procedures, and fee schedule.

The Public Rule relates to the charges of fees and costs for various services related to the Water and Hydroelectric Department from the City of Spokane.

The administrative fees and costs schedule can be found onsite at Water and Hydroelectric Department located at: 914 East North Foothills Drive, Spokane, Washington 99207.

1.2 TABLE OF CONTENTS

- 1.0 GENERAL
- 2.0 DEPARTMENTS/DIVISIONS AFFECTED
- 3.0 REFERENCES
- 4.0 DEFINITIONS
- 5.0 POLICY
- 6.0 PROCEDURE
- 7.0 RESPONSIBILITIES
- 8.0 APPENDICES

2.0 DEPARTMENTS/DIVISIONS AFFECTED

This public rule and policy shall apply to the City of Spokane Water and Hydroelectric Department, the City of Spokane Utilities Billing Department, and the City of Spokane Accounting Department.

### 3.0 REFERENCES

Spokane Municipal Code (SMC) Chapter 13.04  
Chapter 246-290 WAC – Group A Public Water Systems  
Chapter 246-293 WAC – Water System Coordination Act  
Chapter 70A.120 RCW – Public Water Supply System  
City of Spokane Public Rule 4100-20-01, Water Hydrant Usage Policy and Fees dated June 25, 2020.

### 4.0 DEFINITIONS

4.1 See SMC 13.04.0816 & Chapter 13.04 SMC

### 5.0 POLICY

5.1 It is the policy of the City of Spokane to adopt fees for reimbursement of costs for administering the City's Water and Hydroelectric Department programs in compliance with Department of Health regulations.

5.2 The City anticipates annual review and updates to all fees for reimbursement. However, in the event an annual update is not needed, all fees set out in the latest Appendix A shall remain in full effect until modified or amended via the Public Rule process.

### 6.0 PROCEDURE

6.1 The Water & Hydroelectric Department fees and costs for various services related to the Water and Hydroelectric programs and services of the City of Spokane.

6.2 These fees and costs are intended to cover the costs of administration of the Water and Hydroelectric Department, including but not limited to, costs associated with permits, tap and meter connections, monitoring, inspections, sampling, analysis, publication, processing, and violation remediation.

6.3 Current Fees and Charges:

6.3.1 Meter Fees and Tap Fees are charged as stated in Appendix A, attached.

6.3.2 Return Inspection Fees and Reschedule Fees are charged based on actual charges for the number of hours spent and level of work performed.

6.3.3 Administrative Appeal: Two hundred fifty dollars (\$250.00).

6.3.4 Publication of significant non-compliance notice: Costs are billed, and payable in advance.

- 6.3.5 Monitoring, inspection, surveillance, sampling fees: Costs are determined and billed by the Director.
- 6.3.6 Processing fee for NSF checks: As set by City Treasurer.
- 6.3.7 Administrative Penalty: Five hundred dollars (\$500.00)
- 6.3.8 Any other review or approval by the Director not otherwise specified above: Hourly basis based on staff time.

7.0 RESPONSIBILITIES

The Water and Hydroelectric Department through the City’s Utilities Billing Department, and Accounting Department shall administer this Public Rule and Policy. Unpaid charges, fines, and penalties shall, after thirty calendar days (30), be assessed an additional penalty of one percent (1.00%) of the unpaid balance per month.

8.0 APPENDICES

8.1 Appendix A – Meter Fees and Tap Fees for 2025

APPROVED BY:

\_\_\_\_\_  
City Administrator

\_\_\_\_\_  
Date

\_\_\_\_\_  
Division or Department Director

\_\_\_\_\_  
Date

\_\_\_\_\_  
Assistant City Attorney

\_\_\_\_\_  
Date

## APPENDIX A

### ((2024)) 2025 METER FEES & TAP FEES\*

METER FEES	FEE DOLLAR AMOUNT
Type: Hydrant Flow Test	(((\$1,110.86)) <u>\$1,124.19</u> )
Type: After Hours Fee	(((\$1,318.80)) <u>\$1,334.63</u> )
Type: Meter Test Fee	(((\$645.36)) <u>\$653.11</u> )
2" Fire Meter W/ DCDVA	(((\$3,114.71)) <u>\$3,988.10</u> )
Type: Utility Offset (based on 8")	(((\$3,148.43)) <u>\$3,186.21</u> )
Type: 2" Fire Meter W/0 DCDVA	(((\$1,863.28)) <u>\$2,906.34</u> )
Type: 3" Meter- Domestic W/ DCVA	(((\$8,871.20)) <u>\$8,870.90</u> )
Type: 3" Meter - Domestic W/0 DCVA	(((\$7,326.83)) <u>\$7,522.59</u> )
Type: 4" Meter - Domestic W/ DCVA	(((\$10,191.61)) <u>\$10,367.13</u> )
Type: 4" Meter - Domestic W/0 DCVA	(((\$9,426.65)) <u>\$10,033.06</u> )
Type: 6" Meter - Domestic W/ DCVA	(((\$14,983.73)) <u>\$15,882.72</u> )
Type: 6" Meter- Domestic W/0 DCVA	(((\$13,200.79)) <u>\$13,428.63</u> )
Type: 3" Meter- Irrigation W/ DCVA	(((\$7,672.41)) <u>\$7,803.85</u> )
Type: 3" Meter- Irrigation W/0 DCVA	(((\$6,128.04)) <u>\$6,455.54</u> )
Type: 4" Meter - Irrigation W/ DCVA	(((\$8,618.79)) <u>\$8,921.55</u> )
Type: 4" Meter - Irrigation W/0 DCVA	(((\$7,081.83)) <u>\$7,803.18</u> )
Type: 6" Meter- Irrigation W/ DCVA	(((\$13,548.03)) <u>\$13,131.79</u> )
Type: 6" Meter - Irrigation W/0 DCVA	(((\$11,196.05)) <u>\$11,545.96</u> )
Type: 4" Meter - Domestic/Fire W/ DCVA	(((\$13,700.04)) <u>\$10,027.96</u> )
Type: 4" Meter - Domestic/Fire W/0 DCVA	(((\$11,614.30)) <u>\$8,371.29</u> )
Type: 6" Meter - Domestic/Fire W/ DCVA	(((\$18,338.26)) <u>\$12,649.39</u> )

Type: 6" Meter - Domestic/Fire W/0 DCVA	(( <del>\$15,189.41</del> )) <u>\$10,065.16</u>
Type: 8" Meter - Domestic/Fire W/ DCVA	(( <del>\$24,000.38</del> )) <u>\$23,185.35</u>
Type: 8" Meter - Domestic/Fire W/0 DCVA	(( <del>\$19,344.21</del> )) <u>\$19,723.58</u>
Type: 10" Meter - Domestic/Fire W/ DCVA	(( <del>\$33,347.66</del> )) <u>\$28,749.48</u>
Type: 10" Meter - Domestic/Fire W/0 DCVA	(( <del>\$26,970.81</del> )) <u>\$24,864.12</u>
Type: 4" Meter- Fire W/ DCVA	(( <del>\$8,958.19</del> )) <u>\$9,608.95</u>
Type: 6" Meter- Fire W/ DCVA	(( <del>\$11,782.76</del> )) <u>\$12,440.09</u>
Type: 8" Meter- Fire W/ DCVA	(( <del>\$16,064.53</del> )) <u>\$18,939.21</u>
Type: 10" Meter - Fire W/ DCVA	(( <del>\$22,028.63</del> )) <u>\$22,494.52</u>
Type: 4" Meter- Fire W/0 DCVA	(( <del>\$6,147.18</del> )) <u>\$7,641.79</u>
Type: 6" Meter- Fire W/0 DCVA	(( <del>\$7,821.75</del> )) <u>\$9,304.04</u>
Type: 8" Meter-Fire W/0 DCVA	(( <del>\$10,554.53</del> )) <u>\$14,819.15</u>
Type: 10" Meter - Fire W/0 DCVA	(( <del>\$15,500.75</del> )) <u>\$18,119.71</u>
Type: 5/8" Meter – Domestic or Irrigation In PVC Box	(( <del>\$2,436.58</del> )) <u>\$2,465.81</u>
Type: 5/8" Meter – Domestic or Irrigation In Concrete Box	(( <del>\$3,001.48</del> )) <u>\$3,037.49</u>
Type: 5/8" Meter – Domestic or Irrigation In Building	(( <del>\$1,023.96</del> )) <u>\$1,013.00</u>
Type: 5/8" Meter – Domestic or Irrigation In Vault	(( <del>\$1,087.35</del> )) <u>\$1,036.25</u>
Type: 3/4" Meter- Domestic or Irrigation In PVC Box	(( <del>\$2,493.69</del> )) <u>\$2,523.61</u>
Type: 3/4" Meter- Domestic or Irrigation In Concrete Box	(( <del>\$3,058.59</del> )) <u>\$3,095.29</u>
Type: 3/4" Meter- Domestic or Irrigation In Building	(( <del>\$1,081.08</del> )) <u>\$1,070.80</u>
Type: 3/4" Meter – Domestic or Irrigation In Vault	(( <del>\$1,144.46</del> )) <u>\$1,094.05</u>
Type: 1" Meter - Domestic or Irrigation In PVC Box	(( <del>\$2,531.53</del> )) <u>\$2,561.92</u>
Type: 1" Meter - Domestic or Irrigation In Concrete Box	(( <del>\$3,144.16</del> )) <u>\$3,181.89</u>
Type: 1" Meter - Domestic or Irrigation In Building	(( <del>\$1,166.65</del> )) <u>\$1,363.49</u>

Type: 1" Meter - Domestic or Irrigation In Vault	(( <del>\$1,598.83</del> )) <u>\$1,498.33</u>
Type: 1 1/2" Meter - Irrigation	(( <del>\$2,841.23</del> )) <u>\$2,960.37</u>
Type: 1 1/2" Meter - Domestic	(( <del>\$2,759.11</del> )) <u>\$2,817.64</u>
Type: 2" Meter- Irrigation	(( <del>\$2,938.55</del> )) <u>\$2,994.52</u>
Type: 2" Meter - Domestic	(( <del>\$2,914.25</del> )) <u>\$2,982.49</u>
Type: Upsize to 3/4" Meter	(( <del>\$526.96</del> )) <u>\$533.29</u>
Type: Upsize to 1" Meter	(( <del>\$814.89</del> )) <u>\$824.67</u>
Type: Valve Replacement	(( <del>\$415.76</del> )) <u>\$420.75</u>
Type: Frozen 5/8" Meter	(( <del>\$394.11</del> )) <u>\$398.84</u>
Type: Frozen 3/4" Meter	(( <del>\$451.23</del> )) <u>\$456.64</u>
Type: Frozen 1" Meter	(( <del>\$525.03</del> )) <u>\$531.33</u>
Type: Frozen 1 1/2" Meter	(( <del>\$1,004.30</del> )) <u>\$1,016.35</u>
Type: Frozen 2" Meter	(( <del>\$1,159.44</del> )) <u>\$1,173.35</u>
Type: Damaged Meter Remote Repair/Replace	(( <del>\$483.68</del> )) <u>\$489.48</u>
Type: Meter Box Install PVC/Concrete	(( <del>\$2,125.68</del> )) <u>\$2,151.18</u>
Type: Hydrant Lock Remove/Reinstall	(( <del>\$716.06</del> )) <u>\$724.66</u>
<u>Type: Blackflow Test</u>	<u>\$245.35</u>
<u>Type: Meter Appointment reschedule fee</u>	<u>\$81.98</u>

<b>Tap Fees</b>	<b>Fee Dollar Amount</b>
Type: 1" Tap	(( <del>\$1,794.44</del> )) <u>\$1,875.17</u>
Type: 2" Tap	(( <del>\$1,856.60</del> )) <u>\$1,934.29</u>
Type: 4" Tap	(( <del>\$5,817.24</del> )) <u>\$5,952.34</u>
Type: 6" Tap	(( <del>\$5,052.84</del> )) <u>\$5,176.32</u>

Type: 8" Tap	(( <del>\$7,354.56</del> )) <u>\$7,653.07</u>
Type: 10" Tap	(( <del>\$9,241.45</del> )) <u>\$9,400.65</u>
Type: 12" Tap	(( <del>\$10,943.26</del> )) <u>\$11,077.66</u>
Type: Tap Inspection Only Fee	\$161.63

<b>Miscellaneous Fees</b>	<b>Fee Dollar Amount</b>
On Property Water Service Repair	(( <del>\$161.63</del> )) <u>163.56</u>
Chlorination 3,000' or less	(( <del>\$605.35</del> )) <u>\$612.61</u>
Re-Inspection	(( <del>\$161.63</del> )) <u>\$163.56</u>
New Hydrant Install	(( <del>\$10,773.95</del> )) <u>\$10,956.19</u>
Water Main Tie In	(( <del>\$1,129.61</del> )) <u>\$1,143.17</u>
New Install Rescheduling	(( <del>\$405.44</del> )) <u>\$410.30</u>
Type: ¾" to 5/8" Meter downsize (ADU)	<u>\$802.52</u>
Type: 1" to ¾" Meter downsize (ADU)	<u>\$860.29</u>

Updated and revised October 2024

\* In the event an annual update does not occur, all fees set out in the latest Appendix A shall remain in full effect until modified or amended.



**Agenda Sheet for City Council:****Committee:** Urban Experience **Date:** 09/09/2024**Committee Agenda type:** Discussion**Date Rec'd**

8/29/2024

**Clerk's File #**

ORD C36575

**Cross Ref #****Project #****Council Meeting Date:** 09/23/2024**Submitting Dept**

MAYOR

**Bid #****Contact Name/Phone**

ADAM X6779

**Requisition #****Contact E-Mail**

AMCDANIEL@SPOKANECITY.ORG

**Agenda Item Type**

First Reading Ordinance

**Council Sponsor(s)**

KKLITZKE PDILLON

**Agenda Item Name**

0520 - ORDINANCE RE PRESERVATION OF SALVAGEABLE MATERIALS

**Agenda Wording**

Ordinance creating a new chapter 15.06 to SMC and requiring the preservation of salvageable materials from historic properties during demolition or deconstruction.

**Summary (Background)**

Under this ordinance, structures listed on the Spokane Register of Historic Place and structures that are aged 50 years or older and eligible for historic designation will be required to maximize the preservation and reuse of salvageable materials when the property owner seeks to demolish the building. The Historic Preservation Office is charged with implementing this policy and supporting property owners and applicants with guidance on preserving salvageable materials.

Lease? NO

Grant related? NO

Public Works? NO

**Fiscal Impact**

Approved in Current Year Budget? N/A

Total Cost

\$

Current Year Cost

\$

Subsequent Year(s) Cost

\$

**Narrative****Amount****Budget Account**

Select

\$

#

Select

\$

#

Select

\$

#

Select

\$

#

\$

#

\$

#



## ORDINANCE NO C36575

An ordinance regarding the preservation of salvageable material; amending section 08.02.031 of the Spokane Municipal Code; adopting a new chapter 15.06 to Title 15 of the Spokane Municipal Code.

**WHEREAS**, historic preservation programs result in measurable economic development and community revitalization; and

**WHEREAS**, it is a priority of the City of Spokane to preserve and protect Spokane's historic districts, sites, structures, and objects; and

**WHEREAS**, the City of Spokane Comprehensive Plan policy DP 3.12 calls for the City to "Encourage the deconstruction and reuse of historic materials and features when historic buildings are demolished"; and

**WHEREAS**, the implementation of a deconstruction and preservation of salvageable materials policy will ensure that reuseable materials from historical structures are preserved; and

**WHEREAS**, the City of Spokane Comprehensive Plan Policy CFU 5.5 calls for the City to "provide integrated, efficient, and economical solid waste management services in a manner that encourages and promotes waste reductions and recycling and minimizes environmental and public health impacts."

**WHEREAS**, Mayor Brown's Transition Team recommended that Mayor Brown should look to accelerate waste reduction efforts.

**WHEREAS**, the implementation of a deconstruction and preservation of salvageable materials policy will divert demolition from the waste stream and will reduce exposure and the release of toxic particulates into the air and environment.

**WHEREAS**, the City of Spokane Sustainability Action Plan Strategy 3 calls for the City to "promote, support, and incentivize a circular economy"; and

**WHEREAS**, the deconstruction and preservation of salvageable materials can create employment and economic opportunities in recycling industries and provide additional business opportunities; and

**WHEREAS**, SMC 15.05.020 calls for the City to reduce greenhouse gas emissions created within its boundaries; and

**WHEREAS**, the deconstruction and preservation of salvageable materials reduces greenhouse gas emissions by keeping the materials out of landfills.

**NOW, THEREFORE**, the City of Spokane does ordain:

**Section 1.** There is enacted a new chapter 15.06 to Title 15 of the Spokane Municipal Code to read as follows:

Chapter 15.060	Preservation of Salvageable Materials
15.06.010	Purpose and Findings
15.06.020	Definitions
15.06.030	Deconstruction Requirements
15.06.040	Salvageable Materials
15.06.050	Authority of Historic Preservation Office
15.06.060	Compliance
15.06.070	Exemptions

### **15.06.010 Purpose and Findings**

It is a priority of the City of Spokane to reduce waste by promoting, supporting, and incentivizing a circular economy. The City finds that the adoption of a policy requiring the deconstruction of certain structures can maximize the reuse of valuable building materials and reduce emissions associated with the demolition and disposal of building materials.

### **15.06.020 Definitions**

- A. "Deconstruction" means the systematic dismantling of a structure, typically in the opposite order it was constructed, in order to maximize the salvage of materials for reuse, in preference over salvaging materials for recycling, energy recovery, sending the materials to a landfill or the City's Waste-to-Energy Facility.
- B. "Demolition" means the complete or partial removal of a structure from a site.
- C. "Period of Deconstruction" means the period beginning on the date the City issues a demolition permit with deconstruction requirements and ending on the date the City's Historic Preservation Office approves the Post-Deconstruction Form.
- D. "Post-Deconstruction Form" means an inventory of materials salvaged for reuse or for donation, as well as materials disposed of by landfill or through the Waste-to-Energy Facility, completed after the deconstruction is complete.
- E. "Pre-Deconstruction Form" means a salvage plan which includes an inventory of materials to be salvaged for reuse or donation as part of a demolition permit requiring deconstruction.
- F. "Recycling" means the processing of waste materials into new products or material feedstock for products.

G. "Reuse" means the utilization of a product or material that was previously installed for the same or similar function to extend its life cycle. Materials salvageable for reuse include but are not limited to cabinets, doors, hardware, fixtures, flooring, siding, windows, and framing lumber.

H. "Structure" means any building meeting the qualifications of SMC 15.06.030A.

### **15.06.030 Deconstruction Requirements**

A. The deconstruction requirements of this chapter apply to demolition permit applications under SMC 17G.010.100 for structures that have been designated as historic subject to the demolition provisions of SMC 17D.100.230 and structures built 50 years ago or earlier that are eligible for listing on the Spokane Register of Historic Places as determined by the Historic Preservation Office.

B. A property owner or applicant requesting demolition of a structure subject to this chapter shall submit to the Historic Preservation Office a completed Pre-Deconstruction Form listing the targeted salvageable materials and final destinations of the salvaged material along with the required permit and application fees as enumerated in SMC Section 08.02.

C. The Historic Preservation Office shall conduct a site visit and approve the Pre-Deconstruction Form before deconstruction can begin.

D. Upon consent of the property owner or applicant, the Historic Preservation Officer or designee may conduct site inspections throughout the Period of Deconstruction to assure compliance with this chapter.

E. A Post-Deconstruction Form shall be submitted within ten (10) calendar days after completion of the deconstruction work. The Post-Deconstruction Form shall contain the following information:

1. Itemized receipt of materials and quantities donated to a nonprofit or community-based organization;
2. Itemized receipt or photographs of materials and quantities sold;
3. Itemized list and photographs of salvaged material that will be re-used or used at another site; and
4. Transaction receipts or weight tickets for all materials sent to a material recovery facility or disposal facility such as a transfer station, landfill, or the City of Spokane Waste-to-Energy Facility.

F. The Historic Preservation Office shall review and approve the Post-Deconstruction Form

and any additional materials provided to determine compliance with this chapter before the issuance of additional building permits.

G. This chapter requires compliance with all local, state, and federal laws and regulations concerning demolition, testing, abatement, and disposal for any materials containing asbestos, lead, or other hazardous materials.

H. All hauling, sorting, and disposal of materials shall be in compliance with SMC 13.02.0204 and materials designated for disposal must be hauled to a permitted facility located within Spokane County in accordance with Chapter 7.4 and 7.5 of the Spokane Regional Solid Waste Comprehensive Plan.

#### **15.06.040 Preservation of Salvageable Materials**

A. Materials shall be removed by hand to the greatest extent possible to maximize potential for reuse. Nails, screws, or other items used to secure materials in place shall be removed to the greatest extent possible to maximize potential for re-use. Heavy equipment may be used, provided heavy equipment is not used to remove or dismantle components of the structure in ways that render the building materials unsuitable for salvage.

B. The property owner or applicant may sell, donate, or re-use any materials from a deconstruction site before the materials leave the site, provided the property owner or applicant documents the disposition of materials in the Post-Deconstruction Form.

C. Materials shall be stored and covered to protect them from exposure to weather and to permeable ground contact during the period of deconstruction.

#### **15.06.050 Authority of the Historic Preservation Office**

A. The Historic Preservation Office may adopt rules and procedures necessary to implement and enforce the provisions of this chapter.

B. With consent of the property owner or applicant, the Historic Preservation Office may conduct site visits to provide assistance to a property owner or applicant and contractors complying with the provisions of this chapter.

#### **15.06.060 Compliance**

A. This chapter shall be enforced by the Historic Preservation Office under the City’s civil infraction system, pursuant to chapter [01.05 SMC](#). The Historic Preservation Office is the “code enforcement officer” as designated by [SMC 01.05.020\(B\)](#).

B. A violation of this chapter is a class 1 civil infraction.

C. Pursuant to [SMC 01.02.950\(A\)](#), the Historic Preservation Office may refer violations or imminent violations of this chapter to the city attorney for actions in Superior Court seeking declaratory or injunctive relief.

D. Failure to complete deconstruction, removal of materials, and obtain approval of the Post-Deconstruction Form within the period of deconstruction may result in the City completing the deconstruction work of the structure at the applicant or property owner’s expense.

### **15.06.070 Exemptions**

A. A structure may be deemed unsuitable for the deconstruction provisions of this chapter by the Historic Preservation Office in consultation with the Fire Marshal, Code Enforcement, or Building Official if the structure is an imminent threat to life, safety, or property.

B. The Historic Preservation Office may exempt a structure eligible for deconstruction if it is determined that the majority of the material in the structure is not suitable for reuse.

C. A property owner or applicant may make a request for exemption by submitting a written request to the Historic Preservation Office with supporting documentation when submitting a demolition permit application. The Historic Preservation Office shall make a final determination of the exemption request appealable to the Hearing Examiner.

**Section 2.** That Section 08.02.031 of the Spokane Municipal Code is amended as follows:

### **Section 08.02.031 Building Code**

A. Building Permit.

Building permit fees are based on the value of the work to be done as follows:

VALUE OF WORK

(in dollars)

FEE

(in dollars)

1 – 500

28.00

501 - 2,000

28.00 plus 3.00 for each 100 over 500

2,001 - 25,000

73.00 plus 13.00 for each 1,000 over 2,000

25,001 - 50,000

372.00 plus 10.00 for each 1,000 over 25,000

50,001 - 100,000

622.00 plus 7.00 for each 1,000 over 50,000

100,001 - 500,000

972.00 plus 5.00 for each 1,000 over 100,000

500,001 - 1,000,000

2,972.00 plus 4.00 for each 1,000 over 500,000

1,000,001 - 99,999,999

4,972.00 plus 3.00 for each 1,000 over 1,000,000

B. Valuation.

1. The value of construction for purposes of calculating the amount of the fee is determined by using the:
  - a. most current building valuation data from the International Code Council (ICC) as published and updated by the ICC twice annually;  
or
  - b. contract valuation, whichever is greater.



2. "Gross area" when used in conjunction with the ICC building valuation data to determine valuation of a project is the total area of all floors, measured from the exterior face, outside dimension, or exterior column line of a building, including basements and balconies but excluding unexcavated areas.
3. The fee is based on the highest type of construction to which a proposed structure most nearly conforms, as determined by the building official.
4. For roofing permits, the value is determined to be:
  - a. one hundred fifty dollars per square for recovering roofs;
  - b. two hundred dollars per square for roofing projects when existing layers of roofing are torn off and a new layer is installed;
  - c. two hundred fifteen dollars per square for roofing projects when existing layers of roofing are torn off, new sheeting is installed, and a new layer of roof is installed;
  - d. or the contract valuation if it is greater.

#### C. Building Plan Review.

1. Plan review fees are sixty-five percent of the building permit fee as calculated from the table rounded up to the next whole dollar amount for:
  - a. all commercial building permits;
  - b. all industrial building permits;
  - c. all mixed use building permits; and
  - d. new multi-family residences with three or more units.
2. Plan review fees are one hundred percent of the building permit fee as calculated from the table for fast-track projects.
3. Plan review fees are twenty-five percent of the building permit fee as calculated from the table rounded up to the next whole dollar amount for new:
  - a. single-family residences; and
  - b. duplexes.

4. Plan review fees are twenty-five dollars for:
  - a. new buildings that are accessory structures for single-family residences and duplexes to include garages, pole buildings, greenhouses, sheds that require a permit, etc.; and
  - b. additions to existing single family residences and duplexes to include living space, garages, sunrooms, decks, etc.
5. Plan review fees for additional review required by changes, additions, or revisions to plans are seventy-five dollars per hour or fraction thereof.
6. The building official may elect to assess plan review for remodeling single family residences and duplexes when required. This amount will be not be higher than the twenty-five percent of the building fee as calculated in the table rounded to the nearest whole dollar charged on a new single-family residence or duplex.

#### D. Demolition

Demolition permit fees are:

1. Single-family residence, duplex and accessory structures: Thirty-five dollars each.
2. Other structures: Thirty-five dollars for every thousand square feet, to a maximum fee of three hundred fifty dollars.
3. The processing fee is twenty-five dollars.
4. ~~For historic landmarks and contributing buildings within an historic district or located within the Downtown Boundary Area: five hundred dollars. For any listed or contributing building within a Spokane Register Historic District or building determined to be eligible for listing on the Spokane Register of Historic Places: one thousand five hundred dollars.~~
5. All demolition permit fees received by the city are to be deposited in the historic preservation incentives fund established by [SMC 07.08.152](#).

#### E. Fencing.

1. The permit fee is twenty dollars per one hundred linear feet, or fraction thereof.
2. The processing fee and review fee is twenty-five dollars.

F. Grading.

1. Grading permit fees are as follow:

VOLUME

(in cubic yards)

FEE

(in dollars)

100 or less

28.00

100 - 1,000

28.00 plus 12.00 for each 100 over 100

1,001 - 10,000

136.00 plus 10.00 for each 1,000 over 1,000

10,001 - 100,000

226.00 plus 45.00 for each 10,000 over 10,000

100,001 and more

631.0 lus 25.00 for each 10,000 over 100,000

2. Grading plan review fees are as follow:

VOLUME

(in cubic yards)

FEE

(in dollars)

50 or less

None

51 – 100

20.00

101 - 1,000

25.00

1,001 - 10,000

35.00

10,001 - 100,000

35.00 plus 17.00 for each 10,000 over 10,000

100,001 - 200,000

188.00 plus 10.00 for each 10,000 over 100,000

200,001 and more

288.0 plus 5.00 for each 10,000 over 200,000

3. Failure to obtain a grading permit is a class one infraction under [SMC 1.05.150](#).
4. The processing fee is twenty-five dollars.

#### G. Sign Permits.

1. Sign permit fees are:
  - a. thirty dollars for each wall sign, projecting sign and incidental sign; or
  - b. seventy-five dollars for each pole sign, including billboards and off-premises signs.
2. The building services plan review fee is fifty dollars and is in addition to the sign permit fee for pole signs in excess of one hundred square feet or more than thirty feet high.
3. The planning services review fee is fifty dollars for all signs.
4. The processing fee is twenty-five dollars.

#### H. Factory-built Housing.

1. The installation fee for factory-built housing is fifty dollars per section.
2. A foundation or basement requires a separate building permit.
3. Decks, carports and garages require a separate building permit.
4. The development services review fee is fifty dollars.
5. The processing fee is twenty-five dollars.

#### I. Manufactured (Mobile) Home.

1. The installation fee for a manufactured (mobile) home is fifty dollars per section.
2. A basement requires a separate building permit.
3. Decks, carports and garages require a separate building permit.
4. The development services review fee is fifty dollars.
5. The processing fee is twenty-five dollars.

#### J. Temporary Structures.

Permit fees for temporary structures are:

1. One hundred dollars for the first one hundred eighty days; and
2. Five hundred dollars for the second one hundred eighty days.
3. No third session will be allowed.
4. The development services review fee is fifty dollars.
5. The processing fee is twenty-five dollars.

#### K. Relocation.

1. The fee for a building relocation inspection for bond determination is seventy- five dollars.
2. The development services review fee is fifty dollars.

3. The processing fee is twenty-five dollars.
4. Any repairs or alterations required for relocation are handled by various building permits and the fees for such building permits are in addition to the relocation permit fee.

L. Early Start and Fast Track Approval.

The fee for an early start or fast track building permit approval is twenty-five percent of the building permit fee rounded to the next whole dollar amount and is in addition to any other required fees.

M. Certificate of Occupancy.

1. There is no separate fee for the issuance of a certificate of occupancy following final inspection under a permit so long as the fee for the permit is at least fifty dollars; otherwise, the minimum fee for a building permit and certificate of occupancy is fifty dollars plus a twenty-five dollar processing fee.
2. The fees for the issuance of a certificate of occupancy not resulting from work done under permit are as provided in [SMC 8.02.060](#).
3. The building official will assess a fee not to exceed one hundred percent of the building permit fee for the issuance or extension of any temporary certificate of occupancy. The minimum fee will be:
  - a. two hundred twenty-five dollars plus a twenty-five dollar processing fee when the building permit fee exceeds this amount;
  - b. equal to the amount of the building permit fee when the building permit fee is less than two hundred fifty dollars.

N. Swimming Pools.

1. The building and plumbing permit fee for a swimming pool is:
  - a. seventy-five dollars for those accessory to a single-family residence; and
  - b. one hundred dollars for all others.
2. The planning services review fee is twenty-five dollars.
3. The processing fee is twenty-five dollars.

4. Mechanical, electrical and fence permits are additional.

O. Parking Lot and Site Work Permits.

The fee for a site work permit is charged in accordance with the fee table in subsection (A) of this section.

P. Reinspections.

The fee for reinspections for work that was not ready, or corrections previously identified but remain uncorrected, or site not accessible is seventy-five dollars per incident.

Q. Inspections Outside Normal Inspector Working Hours.

The fee for inspections outside normal inspector working hours is seventy-five dollars per hour or fraction of an hour. A minimum of two hours is payable at the time the request is made and before an inspection can be scheduled.

R. Work Done Without a Permit/Investigation Fees.

Where work has commenced without first obtaining the required permit(s), a work without permit fee equivalent to the greater of:

1. twice the inspection fee, or
2. the permit fee plus one hundred fifty dollars, must be paid prior to the issuance of the permit(s).

S. Safety Inspections.

The fees for safety inspections are:

1. Commercial Buildings: Seventy-five dollars per hour or fraction of an hour with a prepaid minimum of one hundred fifty dollars.
2. Single-family Residence – Electrical only: Seventy-five dollars.
3. Single-family Residence – Two or more trade categories: One hundred fifty dollars.
4. Two-family Residence: One hundred seventy-five dollars.
5. Multifamily – Three to six units: Two hundred fifty dollars.

6. Multifamily – Seven to fifty units: Two hundred fifty dollars plus twenty-five dollars for each unit over six.
7. Multifamily – Over fifty units: One thousand three hundred fifty dollars plus ten dollars for every unit over fifty.
8. Electrical Service Reconnect - Residence - Twenty-five dollars
9. Electrical Service Reconnect - Commercial - Fifty dollars
10. Processing fee: Twenty-five dollars.

T. Recording Fee Use of Public Right-of-way and Large Accessory Building Agreement.

The property owner shall be charged a pass-through fee equal to the amount assessed by Spokane County when erecting a fence, retaining wall or other structure in a public right-of-way. This is a recording fee for the acknowledged agreement whereby the property owner covenants to remove the encroachment upon notice by the City. An additional twenty-five dollar processing fee is required when a permit is not issued in conjunction with the recording.

U. Expired Permits Over Six Months.

1. Building Permits.

- a. No inspections have been made: Permits require full resubmittal, and if a commercial project, plan review. Original valuation shall be contained in description of new permit.
- b. Footings and foundations only have been inspected and approved: Minimum of seventy-five percent of the original assessed permit fee plus new processing fees. Original valuation shall be contained in description of new permit.
- c. All rough-in inspections approved: Minimum of twenty-five percent of original permit fee plus new processing fees. Original valuation shall be contained in description of new permit.
- d. Additional work done not on original permit: New valuation shall be calculated based upon either square footage if new construction, or valuation if remodel.

2. Plumbing Permits.

- a. No inspections: A full new permit for all fixtures is required.



- b. Partial inspections approved: If water tests, top outs and ground plumbing have been approved, then twenty-five percent of the original itemized permit fees plus new processing fee.

3. Mechanical Permits.

- a. No inspections: A full new permit is required.
- b. Partial inspections: If all rough-in inspections and air tests have been approved, then twenty-five percent of the original permit fee plus new processing fee.

4. Electrical Permit.

- a. No inspections: A full new permit is required.
- b. Partial inspections: If all rough-in inspections and service inspections have been approved, then twenty-five percent of the original fees plus new processing fee.

V. Processing Fee.

In addition to all of the fees identified in [SMC 8.02.031](#), the processing fee for each permit is twenty-five dollars, unless specifically stated otherwise.

W. Temporary Accessory Dwelling Unit (ADU) Fee Waivers.

- 1. In response to the ongoing local and national housing crisis, the City Council has decided to provide relief to residents and businesses by waiving all applicable fees within this section 08.02.031 associated with the construction of ADUs on lots located at least partially within ½ mile of a Center or Corridor, Context Area, or Downtown zone or CC3 zoning overlay. Distances are measured in a straight line between the zone/overlay boundary to the lot line of the site containing the development.
- 2. The fee waiver described in this subsection 08.02.031(W) shall expire at 5:00 p.m. on December 31, 2024.

X. Solar Permits.

- 1. For single-family residence, duplex, and associated accessory structure installations and modifications eligible for review under the adopted International Residential Codes.
  - a. Plan Review: seventy-five dollars

- b. SFRD Inspection Fee: one hundred fifty dollars
  - c. Electrical Service Fee: assessed in accordance with [SMC 08.02.032\(C\)\(2\)](#).
2. For all other installations and alterations.
- a. Plan Review Fee: sixty-five percent of the MFCOM Inspection Fee.
  - b. MFCOM Inspection Fee: calculated based on the table included in Section 08.02.031(A).
  - c. Electrical Service Fee: assessed in accordance with [SMC 08.02.032\(C\)\(2\)](#).
3. Additional electrical fees in accordance with [SMC 08.02.032](#).
4. Energy Storage Systems: fifty dollars.

**Section 3. Severability.** If any section, subsection, sentence, clause, phrase or word of this ordinance should be held to be invalid or unconstitutional by a court of competent jurisdiction, such invalidity or unconstitutionality thereof shall not affect the validity or constitutionality of any other section, subsection, sentence, clause, phrase or word of this ordinance.

**Section 4. Clerical Errors.** Upon approval by the city attorney, the city clerk is authorized to make necessary corrections to this ordinance, including scrivener's errors or clerical mistakes; references to other local, state, or federal laws, rules, or regulations; or numbering or referencing of ordinances or their sections and subsections.

PASSED by the City Council on \_\_\_\_\_

\_\_\_\_\_  
Council President

Attest:

Approved as to form:

\_\_\_\_\_

\_\_\_\_\_

City Clerk

City Attorney

---

Mayor

---

Date

---

Effective Date



**Agenda Sheet for City Council:**

**Committee:** Urban Experience **Date:** 10/14/2024

**Committee Agenda type:** Discussion

**Date Rec'd**

10/9/2024

**Clerk's File #**

ORD C36597

**Cross Ref #**

**Project #**

**Council Meeting Date:** 10/28/2024

**Submitting Dept**

COMMUNITY, HOUSING & HUMAN

**Bid #**

**Contact Name/Phone**

MELISSA 625-6009

**Requisition #**

**Contact E-Mail**

MMORRISON@SPOKANECITY.ORG

**Agenda Item Type**

First Reading Ordinance

**Council Sponsor(s)**

ZZAPPONE PDILLON LNAVARRETE

**Agenda Item Name**

ALTERING COUNCIL MEMBERSHIP ON CHHS BOARD

**Agenda Wording**

Ordinance revising council members'and Spokane County Membership on CHHS Board to non-voting status.

**Summary (Background)**

Section 04.34A.030 SMC provides that the CHHS Board shall include two City Council members and one representative of Spokane County, all three of whom are voting members of the board. The City Council has been advised that, given that the City Council typically has final authority to decide on grant, awards and funding recommendations from the CHHS board, having voting council members creates an inherent conflict of interest. The ordinance converts their membership to non-voting status.

Lease? NO

Grant related? NO

Public Works? NO

**Fiscal Impact**

Approved in Current Year Budget? N/A

Total Cost \$ NA

Current Year Cost \$ NA

Subsequent Year(s) Cost \$ NA

**Narrative**

No fiscal impact

**Amount**

**Budget Account**

Select \$

#

Select \$

#

Select \$

#

Select \$

#

\$

#

\$

#



## Committee Briefing Paper

### Urban Experience Committee

<b>Committee Date</b>	10/14/24
<b>Submitting Department</b>	Community, Housing and Human Services
<b>Contact Name</b>	Melissa Morrison
<b>Contact Email &amp; Phone</b>	625-6009 /mmorrison@spokanecity.org
<b>Council Sponsor(s)</b>	Dillon, Navarrete, Zappone
<b>Select Agenda Item Type</b>	<input type="checkbox"/> Consent <input checked="" type="checkbox"/> Discussion    Time Requested:
<b>Agenda Item Name</b>	Ordinance Modifying Council Liaisons to CHHS Board
<b>Proposed Council Action</b>	<input checked="" type="checkbox"/> Approval to proceed to Legislative Agenda <input type="checkbox"/> Information Only
<b>Summary (Background)</b>  *use the Fiscal Impact box below for relevant financial information	<p>SMC Chapter 04.34A, enacted in 2018, established the City’s Community, Housing and Human Services Board. The Board advises the City administration, the Mayor, and the City Council regarding community development, housing, and human services programs. Composition of the board, as originally established, included two council members as voting board members as well as a representative of Spokane County, the latter nominated by the Mayor and approved by the City Council.</p> <p>This ordinance amends the existing code to provide that city council members are non-voting members of the CHHS board, and amends the existing code so that the Spokane County representative is also non-voting and is designated by the County. The change is recommended to avoid conflicts of interest for city council members, who often must vote on recommendations coming from the CHHS board.</p>
<b>Fiscal Impact</b> <b>Approved in current year budget?</b> <input type="checkbox"/> Yes <input type="checkbox"/> No <input checked="" type="checkbox"/> N/A Total Cost: <a href="#">Click or tap here to enter text.</a> Current year cost: N/A Subsequent year(s) cost: N/A  <b>Narrative: No identifiable cost to City operations</b>  <b>Funding Source</b> <input type="checkbox"/> One-time <input type="checkbox"/> Recurring <input checked="" type="checkbox"/> N/A Specify funding source: <a href="#">Select Funding Source*</a> Is this funding source sustainable for future years, months, etc? <a href="#">Click or tap here to enter text.</a>  <b>Expense Occurrence</b> <input type="checkbox"/> One-time <input type="checkbox"/> Recurring <input checked="" type="checkbox"/> N/A  Other budget impacts: (revenue generating, match requirements, etc.) <b>None</b>	
<b>Operations Impacts (If N/A, please give a brief description as to why)</b>	

- What impacts would the proposal have on historically excluded communities?

**None. Council participation in the CHHS board will continue.**

- How will data be collected, analyzed, and reported concerning the effect of the program/policy by racial, ethnic, gender identity, national origin, income level, disability, sexual orientation, or other existing disparities?

**Not applicable.**

- How will data be collected regarding the effectiveness of this program, policy, or product to ensure it is the right solution?

**Not applicable**

- Describe how this proposal aligns with current City Policies, including the Comprehensive Plan, Sustainability Action Plan, Capital Improvement Program, Neighborhood Master Plans, Council Resolutions, and others?

**This proposal ensures no inherent or actual conflicts of interest by having City Council members vote on CHHS proposals.**

#### **Council Subcommittee Review**

- Please provide a summary of council subcommittee review. If not reviewed by a council subcommittee, please explain why not.

**Not applicable**

## **ORDINANCE NO. C36597**

An ordinance relating to council membership on the Community Housing and Human Services Board, and amending Section 04.34A.030 of the Spokane Municipal Code.

**WHEREAS**, the Community Housing and Human Services Board (CHHS) was formed in 2012 to act in an advisory role to City administration, the Mayor and City Council regarding community development, housing and human services programs; and

**WHEREAS**, Section 04.34A.030 SMC provides that composition of the CHHS Board shall include two “representatives from the City Council selected by the City Council” and one representative of Spokane County, all three of whom are designated voting members of the board; and

**WHEREAS**, the City Council has been advised that, given that the City Council typically has final authority to decide on grant, awards and funding recommendations from the CHHS board, having voting council members on the CHHS Board creates an inherent conflict for such council members; and

**WHEREAS**, the current voting designation for the county representative is likely a carryover provision from an era when there was no separate Continuum of Care Board for HUD programs; and

**WHEREAS**, City Council desires to maintain council presence on the CHHS board but remove any possible conflicts of interest for such council members, and therefore wishes to convert those positions to non-voting liaison positions and to convert the related county representative to a non-voting liaison position.

**NOW THEREFORE**, the City of Spokane does ordain:

**Section 1.** That Section 04.34A.030 of the Spokane Municipal Code be amended to read as follows:

### **Section 04.34A.030 Membership**

- A. Appointees to the Board shall serve three (3) year terms and may be eligible for one (1) reappointment for a three (3) year term reappointment.
- B. City residence is not a requirement for board membership due to the regional nature of some of the duties and responsibilities of the Board.



- C. The Board will consist of twelve (12) members, nominated by the Mayor and appointed by the City Council. At least one (1) member of the Board shall be a member of a veteran service organization, employed by the Department of Veteran Affairs, or an active duty military member based at Fairchild Air Force Base. In addition, (1) member shall be a liaison from the Community Assembly nominated by the Community Assembly to the Mayor according to the process determined by the Community Assembly and appointed by the City Council.
- D. In addition to the twelve (12) positions, the board will include:
1. two (2) (~~voting representatives~~) non-voting liaisons from the City Council selected by the City Council, appointed or reappointed for one (1) year terms;
  2. one (1) (~~voting~~) non-voting elected official or policy-level decision maker to represent Spokane County who shall be selected by the Spokane County commissioners (~~then nominated by the Mayor and appointed by City Council, appointed or reappointed for one (1) year terms~~).
- E. Members of the Board and Board committees shall include relevant representation in compliance with HUD and Washington State Department of Commerce requirements.
- F. Board members shall serve without compensation.
- G. Board members will meet conflict of interest requirements. Committee members may be required to meet conflict of interest requirements.
- H. The membership as a whole shall reflect a broad range of opinion, experience, and expertise with the object of providing sound advice, representative of the citizenry. To achieve that purpose, it shall include residents from diverse neighborhoods within the City and County, with diverse professional backgrounds and citizens active in neighborhood or community affairs. Youth may also serve as members.

**Section 3. Severability.** If any section, subsection, sentence, clause, phrase or word of this ordinance should be held to be invalid or unconstitutional by a court of competent jurisdiction, such invalidity or unconstitutionality thereof shall not affect the validity or constitutionality of any other section, subsection, sentence, clause, phrase or word of this ordinance.

**Section 4. Clerical Errors.** Upon approval by the city attorney, the city clerk is authorized to make necessary corrections to this ordinance, including scrivener’s errors or clerical mistakes; references to other local, state, or federal laws, rules, or regulations; or numbering or referencing of ordinances or their sections and subsections.

**PASSED** by the City Council on \_\_\_\_\_.

\_\_\_\_\_  
Council President

Attest:

Approved as to form:

\_\_\_\_\_  
City Clerk

\_\_\_\_\_  
Assistant City Attorney

\_\_\_\_\_  
Mayor

\_\_\_\_\_  
Date

\_\_\_\_\_  
Effective Date

**Agenda Sheet for City Council:****Committee:** PIES **Date:** 10/21/2024**Committee Agenda type:** Discussion**Date Rec'd**

10/22/2024

**Clerk's File #**

ORD C36600

**Cross Ref #****Project #****Council Meeting Date:** 11/04/2024**Submitting Dept**

CITY COUNCIL

**Bid #****Contact Name/Phone**

ABIGAIL 625-6246

**Requisition #****Contact E-Mail**

AMMARTIN@SPOKANECITY.ORG

**Agenda Item Type**

First Reading Ordinance

**Council Sponsor(s)**

BWILKERSON ZZAPPONE

**Agenda Item Name**

0320 – ORDINANCE AMENDING TRANSPORTATION COMMISSION PROVISIONS

**Agenda Wording**

Ordinance amending SMC 04.40 to clarify that liaison positions on the newly-created Transportation Commission are selected by their representative organizations, and repealing SMC 12.01 relating to the Citizens Streets Advisory Commission (CSAC).

**Summary (Background)**

The City Council created the Citizens Streets Advisory Commission (CSAC) in 2004 to review construction of city streets. The duties of the CSAC have been subsumed into the duties of the newly created Transportation Commission, and due to an oversight the sections of the code relating to the CSAC were not repealed. The proposed ordinance also clarifies that liaison positions on the Transportation Commission are selected by their represented organizations.

Lease? NO

Grant related? NO

Public Works? NO

**Fiscal Impact**

Approved in Current Year Budget? N/A

Total Cost

\$

Current Year Cost

\$

Subsequent Year(s) Cost

\$

**Narrative**

No fiscal impact

**Amount****Budget Account**

Select

\$

#

Select

\$

#

Select

\$

#

Select

\$

#

\$

#

\$

#



## Committee Briefing Paper

### Public Infrastructure, Environment & Sustainability Committee

<b>Committee Date</b>	10.21.2024
<b>Submitting Department</b>	Office of the City Council
<b>Contact Name</b>	Abigail Martin
<b>Contact Email &amp; Phone</b>	<a href="mailto:ammartin@spokanecity.org">ammartin@spokanecity.org</a> x6426
<b>Council Sponsor(s)</b>	Council President Wilkerson
<b>Select Agenda Item Type</b>	<input type="checkbox"/> Consent <input checked="" type="checkbox"/> Discussion    Time Requested: 5 minutes
<b>Agenda Item Name</b>	0320 – Ordinance Amending Transportation Commission Provisions
<b>Proposed Council Action</b>	<input checked="" type="checkbox"/> Approval to proceed to Legislative Agenda <input type="checkbox"/> Information Only
<b>Summary (Background)</b>  *use the Fiscal Impact box below for relevant financial information	<p>The City Council recently enact Ordinance C36517, creating the Transportation Commission. The proposed ordinance is intended to make two technical amendments.</p> <p>First, in 2004 the City Council adopted Ordinance C33507 creating the Citizens Streets Advisory Commission (CSAC) to review the “plans, cost, timeliness, appropriate use of materials and technology” relating to construction of city streets. The functions and duties of the CSAC have been subsumed into the functions and duties of the newly created Transportation Commission, and due to an oversight, the sections of the Spokane Municipal Code relating to the CSAC were not repealed as part of Ordinance C36517. This proposed ordinance corrects that oversight.</p> <p>Second, the proposed ordinance amends SMC 04.40.050 to clarify that liaison positions are selected by the organizations they represent and not nominated by the Mayor or subject to confirmation by the City Council.</p>
<b>Fiscal Impact</b> <b>Approved in current year budget?</b> <input type="checkbox"/> Yes <input type="checkbox"/> No <input checked="" type="checkbox"/> N/A Total Cost: <u>N/A</u> Current year cost: Subsequent year(s) cost:	
<b>Narrative:</b> <u>N/A</u>	
<b>Funding Source</b> <input type="checkbox"/> One-time <input type="checkbox"/> Recurring <input checked="" type="checkbox"/> N/A Specify funding source: Select Funding Source* Is this funding source sustainable for future years, months, etc? <a href="#">Click or tap here to enter text.</a>	
<b>Expense Occurrence</b> <input type="checkbox"/> One-time <input type="checkbox"/> Recurring <input checked="" type="checkbox"/> N/A  Other budget impacts: (revenue generating, match requirements, etc.) N/A	
<b>Operations Impacts</b> (If N/A, please give a brief description as to why) <ul style="list-style-type: none"> <li>• What impacts would the proposal have on historically excluded communities?</li> </ul>	

**The Community Assembly is comprised of the Neighborhood Council system which includes the city's 29 neighborhoods. The Community Assembly liaison to the Transportation Commission will ensure the Community Assembly is kept apprised of the commission's work and that the commission is informed about the Community Assembly's positions.**

**The second amendment to the ordinance cleans up our SMC boards and commissions and allows the Transportation Commission take on the full extent of transportation related issues in the city.**

- How will data be collected, analyzed, and reported concerning the effect of the program/policy by racial, ethnic, gender identity, national origin, income level, disability, sexual orientation, or other existing disparities?

**Staff will regularly present and serve the business of the Transportation Commission including safety and equity information within our transportation system. Regular reporting will occur before this commission to ensure transparency. Meetings are open to the public.**

- How will data be collected regarding the effectiveness of this program, policy, or product to ensure it is the right solution?

**The new Transportation Commission will have the benefit of the work product of previous transportation-related board and commissions, which will inform whether the new commission's work plans are productive and efficient.**

- Describe how this proposal aligns with current City Policies, including the Comprehensive Plan, Sustainability Action Plan, Capital Improvement Program, Neighborhood Master Plans, Council Resolutions, and others?

**These amendments correct word choice for the Community Assembly's liaison position, aligning the position with the Charter's language. These amendments also clean up our Code so that it properly reflects existing boards and commissions.**

#### **Council Subcommittee Review**

- Please provide a summary of council subcommittee review. If not reviewed by a council subcommittee, please explain why not.

**While not reviewed at a Traffic Calming meeting, the Council Members comprising the Traffic Calming subcommittee are aware of the need for these changes.**

## **ORDINANCE NO. C36600**

An ordinance relating to oversight of transportation infrastructure, amending Section 04.40.050 of the Spokane Municipal Code, and repealing sections 12.01.200 through 12.01.210 of the Spokane Municipal Code.

**WHEREAS**, the Transportation Commission was formed by the City Council via adoption of Ordinance C36517, codified as Chapter 04.40 of the Spokane Municipal Code and effective August 2, 2024; and

**WHEREAS**, Section 04.40.050 SMC includes several liaison positions on the Transportation Commission, which positions were intended to be non-voting and selected by the organizations represented by the liaisons; and

**WHEREAS**, the City Council wishes to amend the Spokane Municipal Code to confirm that liaison positions are selected by the organizations they represent and not nominated by the Mayor or subject to confirmation by the City Council; and

**WHEREAS**, in 2004 the City Council adopted Ordinance C33507 creating the Citizens Streets Advisory Commission (CSAC) to review the “plans, cost, timeliness, appropriate use of materials and technology” relating to construction of city streets; and

**WHEREAS**, the functions and duties of the CSAC have been subsumed into the functions and duties of the newly created Transportation Commission; and

**WHEREAS**, due to an oversight, the sections of the Spokane Municipal Code relating to the CSAC were not repealed as part of Ordinance C36517.

**NOW THEREFORE**, the City of Spokane does ordain:

**Section 1.** Article VII, Sections 12.01.200 through 12.01.210 of the Spokane Municipal Code, relating to the Citizens Streets Advisory Commission, is repealed.

**Section 2.** That Section 04.40.050 of the Spokane Municipal Code be amended to read as follows:

### Section 04.40.050 Liaison Members

- A. Representatives of the following agencies with transportation interests within the city of Spokane may join the Transportation Commission as members in liaison roles: Spokane Transit Authority, Spokane Regional Transportation Council, Washington

State Department of Transportation, Spokane Regional Health District, Parking and Business Improvement Area, Downtown Spokane, Partnership, University District Public Development Authority, the Northeast Public Development Authority, the West Plains / Airport Area Public Development Authority (S3R3 Solutions), and Spokane Public Schools. Additional liaisons representing agencies not listed in this section may be admitted upon majority vote of the Commission.

- B. The City Council shall appoint up to three city council members to serve as liaisons to the Transportation Commission.
- C. The Community Assembly may ~~((nominate a member of the assembly))~~ select an individual to serve as ~~((a))~~ its liaison to the Transportation Commission.
- D. Liaison members shall be non-voting members ~~((in))~~ of the Transportation Commission ~~((business))~~.
- E. Liaison members shall be selected by the agency or body represented on the Transportation Commission and shall not be subject to mayoral appointment or council approval of their appointment.
- F. The Community Assembly and any agency with a representative serving as a liaison to the Transportation Commission may ~~((identify))~~ select an alternate ~~((member of the assembly or agency))~~ to serve in the absence of the designated liaison.

**Section 3. Severability.** If any section, subsection, sentence, clause, phrase or word of this ordinance should be held to be invalid or unconstitutional by a court of competent jurisdiction, such invalidity or unconstitutionality thereof shall not affect the validity or constitutionality of any other section, subsection, sentence, clause, phrase or word of this ordinance.

**Section 4. Clerical Errors.** Upon approval by the city attorney, the city clerk is authorized to make necessary corrections to this ordinance, including scrivener's errors or clerical mistakes; references to other local, state, or federal laws, rules, or regulations; or numbering or referencing of ordinances or their sections and subsections.

**PASSED** by the City Council on \_\_\_\_\_.



\_\_\_\_\_  
Council President

Attest:

Approved as to form:

\_\_\_\_\_  
City Clerk

\_\_\_\_\_  
Assistant City Attorney

\_\_\_\_\_  
Mayor

\_\_\_\_\_  
Date

\_\_\_\_\_  
Effective Date

ORD C36600 (ZAPPONE AMENDMENT)(10-31-24)

1. Strike the following sentence from Section 2:

~~((B. The City Council shall appoint up to three city council members to serve as liaisons to the Transportation Commission.))~~

2. Substitute the following sentence in its place:

B. All council members shall serve as liaisons to the Transportation Commission.

This amendment would allow all council members to attend the Transportation Commission regular meetings without appointment.



**Agenda Sheet for City Council:**

**Committee:** PIES **Date:** 10/21/2024

**Committee Agenda type:** Discussion

**Date Rec'd** 10/22/2024

**Clerk's File #** ORD C36601

**Cross Ref #**

**Project #**

**Council Meeting Date:** 11/04/2024

**Submitting Dept** CITY COUNCIL

**Bid #**

**Contact Name/Phone** ABIGAIL 625-6246

**Requisition #**

**Contact E-Mail** AMMARTIN@SPOKANECITY.ORG

**Agenda Item Type** First Reading Ordinance

**Council Sponsor(s)** ZZAPPONE KKLITZKE PDILLON

**Agenda Item Name** 0320- ORDINANCE CONCERNING REVENUES FROM AUTOMATED SAFETY

**Agenda Wording**

An ordinance relating to revenue from automated safety cameras, renaming the Traffic Calming Fund the "Spokane Safe Streets Fund,"(SSS), and amending Sections 07.08.148, 16A.64.210, and 16A.64A.220 of the Spokane Municipal Code.

**Summary (Background)**

In June 2024, the Washington Legislature enacted HB 2384, dramatically altering state laws regarding local use of automated traffic safety cameras, including permissible locations, use of revenues, and issuance of infractions. The proposed ordinance is intended to conform local law to the requirements of HB 2384, and to modify the nomenclature around automated safety camera revenues to more accurately reflect the City's intended use of the funds, and defines permissible use of the fund.

Lease? NO Grant related? NO Public Works? NO

**Fiscal Impact**

Approved in Current Year Budget? N/A

Total Cost \$

Current Year Cost \$

Subsequent Year(s) Cost \$

**Narrative**

The Traffic Calming Fund is financed by revenues generated through the automated safety camera program. This ordinance is unlikely to have any effect on general fund expenditures.

**Amount**

**Budget Account**

Select \$ #

Select \$ #

Select \$ #

Select \$ #

\$ #

\$ #



## Continuation of Wording, Summary, Approvals, and Distribution

### Agenda Wording

### Summary (Background)

#### **Approvals**

Dept Head

Division Director

Accounting Manager

Legal

For the Mayor

ORLOB, KIMBERLY

SCHOEDEL, ELIZABETH

#### **Additional Approvals**

#### **Distribution List**

nzollinger@spokanecity.org

korlob@spokanecity.org

## Committee Briefing Paper

### Public Infrastructure, Environment & Sustainability Committee

<b>Committee Date</b>	10.21.2024
<b>Submitting Department</b>	Office of the City Council
<b>Contact Name</b>	Abigail Martin
<b>Contact Email &amp; Phone</b>	<a href="mailto:ammartin@spokanecity.org">ammartin@spokanecity.org</a> x6426
<b>Council Sponsor(s)</b>	Council President Wilkerson
<b>Select Agenda Item Type</b>	<input type="checkbox"/> Consent <input checked="" type="checkbox"/> Discussion    Time Requested: 10 minutes
<b>Agenda Item Name</b>	ORD to define and scope proper use of Traffic Calming fund
<b>Proposed Council Action</b>	<input checked="" type="checkbox"/> Approval to proceed to Legislative Agenda <input type="checkbox"/> Information Only
<b>Summary (Background)</b>  *use the Fiscal Impact box below for relevant financial information	<p>The Traffic Calming Measures Fund, set forth in SMC 07.08.148, was established in 2010 to collect revenues from automated traffic safety camera infractions as allowed under state law. The specific provisions related to automated safety camera provisions are set forth in SMC 16A.64. Prior to June 2024, local governments were limited in the use and locations of automated safety cameras, but not limited in their use of the revenues.</p> <p>In June 2024, the Washington Legislature enacted HB 2384, dramatically altering state laws regarding local use of automated traffic safety cameras, including permissible locations, use of revenues, and issuance of infractions.</p> <p>The proposed ordinance is intended to conform local law to the requirements of HB 2384, and to modify the nomenclature around automated safety camera revenues to more accurately reflect the City's intended use of the funds. The ordinance does the following:</p> <ul style="list-style-type: none"> <li>• Renames the "Traffic Calming Measures Fund" to the "Spokane Safe Streets Fund"</li> <li>• Establishes definitions and permissible uses of revenues in the Spokane Safe Streets Fund, including projects that serve Spokane's neighborhoods by calming traffic, enhancing safe streets for all users, and facilitating a multimodal transportation network.</li> </ul>
<b>Fiscal Impact</b> <b>Approved in current year budget?</b> <input type="checkbox"/> Yes <input type="checkbox"/> No <input checked="" type="checkbox"/> N/A Total Cost: <u>N/A</u> Current year cost: Subsequent year(s) cost:	
<b>Narrative:</b> _The Traffic Calming Fund is financed by revenues generated through the automated safety camera program. This ordinance is unlikely to have any effect on general fund expenditures, although changes in state law are likely to make TCF funds less available for some purposes to which they have historically been used, such as supplanting the police budget.	
<b>Funding Source</b> <input type="checkbox"/> One-time <input type="checkbox"/> Recurring <input checked="" type="checkbox"/> N/A	

Specify funding source: Select Funding Source\*

Is this funding source sustainable for future years, months, etc? N/A

**Expense Occurrence**     One-time     Recurring     N/A

Other budget impacts: (revenue generating, match requirements, etc.) N/A

**Operations Impacts** (If N/A, please give a brief description as to why)

- What impacts would the proposal have on historically excluded communities?

**Staff and the City Council's Traffic Calming subcommittee have been meeting together regularly since the beginning of 2024 in order to line up timing of different department's workplans and needs as they pertain to Traffic Calming. Many departments draw on the Traffic Calming fund and this ordinance to ensure that the fund is used to make our Spokane streets safer for all users. The fund's use also considers historical funding by neighborhood, community safety needs and risk, and equity.**

- How will data be collected, analyzed, and reported concerning the effect of the program/policy by racial, ethnic, gender identity, national origin, income level, disability, sexual orientation, or other existing disparities?

**This ordinance considers the intent and purpose of the Traffic Calming fund including historical funding context and neighborhood investment (or lack thereof), safety, and multimodal function for all users.**

- How will data be collected regarding the effectiveness of this program, policy, or product to ensure it is the right solution?

**Many different departments collaborated to ensure the defining and scope of the Traffic Calming fund, its purview and functions, worked for the safety data collected, analysis conducted, future projects scoped and strategically aligned.**

- Describe how this proposal aligns with current City Policies, including the Comprehensive Plan, Sustainability Action Plan, Capital Improvement Program, Neighborhood Master Plans, Council Resolutions, and others?

**This ordinance establishes intent and purpose, a very definition, for a fund that has been referenced but never clearly laid out. This ordinance allows for the Traffic Calming fund to come into alignment with operations, the Neighborhood Councils hopes for their Traffic Calming projects, Council resolution to for projects already committed, and state law.**

**Council Subcommittee Review**

- Please provide a summary of council subcommittee review. If not reviewed by a council subcommittee, please explain why not.

**This Ordinance has been reviewed at several Traffic Calming meetings, jointly by the Council subcommittee and staff.**

## **ORDINANCE NO. C36601**

An ordinance relating to revenue from automated safety cameras, renaming the Traffic Calming Fund the “Spokane Safe Streets for All Fund,” amending Sections 07.08.148, 16A.64.220 and 16A.64.240 of the Spokane Municipal Code, and repealing Section 16A.64.260 of the Spokane Municipal Code.

WHEREAS, RCW 46.63 authorizes local jurisdictions to install and operate automated traffic safety cameras as a means for enforcing traffic laws; and

WHEREAS, consistent with RCW 46.63, the Spokane City Council adopted Spokane Municipal Code Chapter 16A.64 which, in pertinent part, authorized the use of automated traffic safety cameras in the City of Spokane at two-arterial intersections and school speeding zones; and

WHEREAS, on August 26, 2019, the City Council enacted ordinance C35809, establishing new Section 07.08.148 in the Spokane Municipal Code to create the “Traffic Calming Fund” into which funds from automated traffic safety camera infractions were deposited; and

WHEREAS, under SMC 07.08.148, funds in the Traffic Calming Fund are to be used to pay for “traffic calming measures” and such operational expenses associated with the automated safety camera program; and

WHEREAS, in 2022 the Washington Legislature enacted Engrossed Substitute Senate Bill 5974, which expanded the permitted uses of automated traffic safety cameras under RCW 46.63 to include the detection of speed violations in roadways and school walk areas as defined in RCW 28A.160.160, as well as speed violations in public park speed zones and hospital speed zones; and

WHEREAS, effective September 1, 2023 the City Council enacted Ordinance C36407, which amended Spokane Municipal Code to expand the use of automated safety cameras in park areas and hospital zones; and

WHEREAS, in 2024 the Washington Legislature enacted Engrossed Substitute Senate Bill 2384, which expanded the allowed uses and locations of automated safety cameras, defined allowed uses of revenues generated from automated safety-camera programs, permitted the use of non-commissioned individuals to review infractions, and enacted other provisions relating to automated safety cameras; and

WHEREAS, since its inception in 2007, revenues from the use of automated safety cameras in the city have grown significantly, and the Traffic Calming Fund established under SMC 07.08.148 has necessarily grown as well, increasing the opportunities for installation of traffic calming measures and other programs to ensure safe streets for all Spokane citizens; and

WHEREAS, vehicle, pedestrian and bicycle safety concepts have evolved since the initial creation of the Traffic Calming Fund, and local safety programs extend beyond traffic calming infrastructure improvements to incorporate a more comprehensive approach toward traffic safety, such as the United States Department of Transportation “Safe System Approach” and the USDOT “Safe Streets 4 All” grant program (“SS4A”); and

WHEREAS, the phrase “traffic calming measures” is not defined in the Spokane Municipal Code and is an outdated concept, and is not well-defined at the administrative or legislative levels, creating less certainty as to which projects are suitable for funding by the Traffic Calming Fund; and

WHEREAS, Engrossed Substitute Senate Bill 2384 clarifies appropriate uses of revenues generated by automated safety cameras; and

WHEREAS, as early as 2011, and in concert with the Community Assembly, the City approved administrative policies for placement of automated safety cameras and for uses of revenues in the Traffic Calming Fund, which policies need to be updated to reflect the current practices and procedures relating to use of Traffic Calming Funds; and

WHEREAS, on June 24, 2024, the City Council adopted resolution 2024-0053, the “Janet Mann Safe Streets Now!” resolution to encourage the administration to implement adaptive design strategies as part of the City’s traffic calming program and transportation infrastructure, and

WHEREAS, the Council desires to rename the Traffic Calming Fund to better reflect the uses and opportunities for funding for vehicle, pedestrian and bicycle safety measures, to set forth the types of programs and projects eligible for funding from revenues generated by automated safety cameras consistent with Engrossed Substitute Senate Bill 2384, to ensure that such funds are appropriated within general fund expenditures in a manner that is specifically and demonstrably connected to modern concepts for road safety as well as traffic calming, and finally to create procedures to ensure the fair, sensible and foresighted use of such funds.

**NOW THEREFORE**, the City of Spokane does ordain:

**Section 1.** That Article II, Section 07.08.148 of the Spokane Municipal Code to is amended to read as follows:

Section 07.08.148 (~~Traffic Calming Measures~~) Spokane Safe Streets for All Fund.

A. Establishment of Fund. There is established a special revenue fund to be known as the (~~“Traffic Calming Measures Fund”~~) Spokane Safe Streets for All Fund (the “Safe



Streets for All Fund”) into which shall be deposited funds from automated traffic safety camera infractions in excess of the direct administrative costs of the automated traffic safety camera program. The ~~((fund))~~ Safe Streets for All Fund will be used to pay for ~~((traffic calming measures and))~~ operational expenses directly related to the automated traffic safety camera program as are approved by the City Council by resolution~~((,-))~~ or special budget ordinance, and for construction and maintenance of the following safe streets measures consistent with RCW 46.63:

1. Roadway infrastructure improvements with a demonstrable connection to safe systems improvements;
2. Operational expenses with a demonstrable connection to pedestrian and bicycle safety;
3. Sidewalk repair and safety programs;
4. Funding of personnel for community outreach and to encourage citizen input into safe streets measures and projects;
5. Funding of engineering and project personnel to ensure timely design and construction of safety infrastructure;
6. Implementation of programs, including grant applications, that follow the USDOT “Safe System Approach,” including focus on driver safety, safer roads, safer vehicles, safer speeds, and post-crash care;
7. Implementation of adaptive design strategies into the City’s transportation infrastructure; and
8. Such other measures, programs and improvements approved by the City Council and permitted by state law.

B. Appropriations from the Spokane Safe Streets for All Fund. Funds from the Safe Streets for All Fund shall be appropriated by the city council as part of the annual city budget, pursuant to special budget ordinance, or both. In making appropriations the City Council may consider recommendations of the City of Spokane Transportation Commission and Neighborhood Councils with regard to projects and priorities. When feasible, all appropriations from the Safe Streets for All Fund shall be approved by the city council no later than April 1 of the year in which such funds are to be encumbered.

C. Minimum Allocation to Specified Census Tracts. Expenditures from the Safe Streets for All Funds shall be consistent with the allocation requirements in RCW 46.63.220 (13)(b) as amended from time to time.

**Section 2.** That Section 16A.64.220 of the Spokane Municipal Code is amended to read:

## Section 16A.64.220 Procedures of Use of Automated Traffic Safety Cameras

The use of automated traffic safety cameras is authorized for issuance of notices of infraction for violations regarding obedience to traffic control devices (~~((for stoplights at two-arterial intersection and school speeding zones and))~~) and speed violations is subject to the following requirements:

- A. Use of automated traffic safety cameras is restricted to the following locations:
1. For stoplight violations only, at two-arterial intersections as defined in RCW 46.63.230((~~7~~));
  2. School walk (~~((areas))~~) zones, as defined in RCW 46.63.210(~~7~~)((~~7~~));
  4. School speed zone, as defined in RCW 46.63.210;
  5. Public park speed zones, as defined in RCW (~~46.63.170, and~~) 46.63.210;
  6. Hospital speed zones, as defined in RCW (~~46.63.170~~) 46.63.210;
  7. Roadway work zones on city streets, as defined in RCW 46.63.210;
  8. State highways within city limits and classified as city streets pursuant to RCW 47.24; and
  9. For failure to stop at an activated railroad grade crossing control signal only, at railroad grade crossings.
- B. Automated traffic safety cameras may only take pictures of the vehicle and vehicle license plate and only while an infraction is occurring. The picture must not reveal the face of the driver or of passengers in the vehicle.
- C. A notice of infraction must be mailed to the registered owner of the vehicle within fourteen days of the violation, or to the renter of a vehicle within fourteen days of establishing the renter's name and address under SMC 16A.64.240(B). The (~~law enforcement officer issuing the~~) notice of infraction shall include with it a certificate or facsimile thereof, based upon inspection of photographs, microphotographs, or electronic images produced by an automated traffic safety camera, stating the facts supporting the notice of infraction. This certificate or facsimile is prima facie evidence of the facts contained in it and is admissible in a proceeding charging a violation under this chapter. The photographs, microphotographs or electronic images evidencing the violation must be available for inspection and admission into evidence in a proceeding to adjudicate the liability for the infraction. A person

receiving a notice of infraction based on evidence detected by an automated traffic safety camera may respond to the notice by mail.

- D. The registered owner of a vehicle is responsible for an infraction under SMC 16A.64.270(A) unless the registered owner overcomes the presumption in SMC 16A.64.270(B), or, in the case of a rental car business, satisfies the conditions under SMC 16A.64.240(B). If appropriate under the circumstances, a renter identified under SMC 16A.64.240(B)(1) is responsible for an infraction.
- E. Pursuant to RCW (~~(46.63.170(1)(f))~~) 46.63.160(6)(6), notwithstanding any other provision of law, all photographs, microphotographs, or electronic images prepared under this section are for the exclusive use of law enforcement in the discharge of duties under this section and are not open to the public and may not be used in a court in a pending action or proceeding unless the action or proceeding relates to a violation under this section. No photograph, microphotograph or electronic image may be used for any purpose other than enforcement of violations under this section nor retained longer than necessary to enforce this section.
- F. All locations where an automated traffic safety camera is used must be clearly marked by placing signs in locations that clearly indicate to a driver that (~~he~~) the driver is entering a zone where traffic laws are enforced by an automated traffic safety camera. Signage in public park speed zones and hospital speed zones shall conform to the requirements in RCW (~~(46.63.170)~~) 46.63.220.

**Section 3.** That Section 16A.64.240 of the Spokane Municipal Code is amended to read:

#### Section 16A.64.240 Notice and Disposition of Traffic Infractions

- A. Infractions detected through the use of automated traffic safety cameras are not part of the registered owner's driving record under RCW 46.52.101 and RCW 46.52.120. Additionally, infractions and resulting penalties generated by the use of automated traffic safety cameras under this section shall be processed in the same manner as parking infractions(~~(, (including for the purposes of))~~) under state law, including, but not limited to RCW 3.46.120, RCW 3.50.100, RCW 35.20.220, RCW (~~(46.16.216)~~) 46.16A.120, (~~and~~) RCW 46.20.270(3), RCW 46.63.110, RCW 46.63.190, and RCW 46.63.220, as they may be amended from time to time . A notice of infraction for (~~stoplight and school speed zone~~) violations detected through the use of automated traffic safety cameras shall result in a fine equal to the total penalty, including the base penalty plus any statutory assessments

authorized under state law, for such violations otherwise detected by a police officer.

- B. If the registered owner of the vehicle is a rental car business, the police department shall, before a notice of infraction being issued under this section, provide a written notice to the rental car business that a notice of infraction may be issued to the rental car business if the rental car business does not, within eighteen days of receiving the written notice, provide to the police department by return mail:
1. a statement under oath stating the name and known mailing address of the individual driving or renting the vehicle when the infraction occurred; or
  2. a statement under oath that the business is unable to determine who was driving or renting the vehicle at the time the infraction occurred; or
  3. in lieu of identifying the vehicle operator, the rental car business may pay the applicable penalty.

Timely mailing of this statement to the police department relieves a rental car business of any liability under this section for the notice of infraction.

- C. Nothing in this section prohibits a law enforcement officer from issuing a notice of traffic infraction at the time a violation occurs to a person in control of a vehicle under the Washington Model Traffic Ordinance.

- D. The court may, in its discretion, waive, reduce, or suspend the monetary penalty prescribed for the infraction. At the person's request, the court may order performance of a number of hours of community restitution in lieu of a monetary penalty, at the rate of the then state minimum wage per hour.

1. Except as provided in this subsection, registered owners of vehicles who receive notices of infraction for automated traffic safety camera-enforced infractions and are recipients of public assistance under Title 74 RCW or participants in the Washington women, infants, and children program, and who request reduced penalties for infractions detected through the use of automated traffic safety camera violations, must be granted reduced penalty amounts of 50 percent of what would otherwise be assessed for a first automated traffic safety camera violation and for subsequent automated traffic safety camera violations issued within 21 days of issuance of the first automated traffic safety camera violation. Eligibility for Medicaid under RCW 74.09.510 is not a qualifying criterion under this subsection. Registered owners of vehicles who receive notices of infraction must be provided with information on their eligibility and the opportunity to apply for a reduction in penalty amounts through the mail or internet.

**Section 4.** Section 16A.64.260 of the Spokane Municipal Code is repealed.

**Section 5. Severability.** If any section, subsection, sentence, clause, phrase or word of this ordinance should be held to be invalid or unconstitutional by a court of competent jurisdiction, such invalidity or unconstitutionality thereof shall not affect the validity or constitutionality of any other section, subsection, sentence, clause, phrase or word of this ordinance.

**Section 6. Clerical Errors.** Upon approval by the city attorney, the city clerk is authorized to make necessary corrections to this ordinance, including scrivener's errors or clerical mistakes; references to other local, state, or federal laws, rules, or regulations; or numbering or referencing of ordinances or their sections and subsections.

**PASSED** by the City Council on \_\_\_\_\_

\_\_\_\_\_  
Council President

Attest:

Approved as to form:

\_\_\_\_\_  
City Clerk

\_\_\_\_\_  
Assistant City Attorney

\_\_\_\_\_  
Mayor

\_\_\_\_\_  
Date

\_\_\_\_\_  
Effective Date

Streets Fund”) into which shall be deposited funds from automated traffic safety camera infractions in excess of the direct administrative costs of the automated traffic safety camera program. The ((fund)) Safe Streets Fund will be used to pay for ((traffic calming measures and)) operational expenses directly related to the automated traffic safety camera program as are approved by the City Council by resolution((,-)) or special budget ordinance, and for construction and maintenance of the following safe streets measures consistent with RCW 46.63:

1. Roadway infrastructure improvements with a demonstrable connection to safe systems improvements;
2. Operational expenses with a demonstrable connection to pedestrian and bicycle safety;
3. Sidewalk repair and safety programs;
4. Funding of personnel for community outreach and to encourage citizen input into safe streets measures and projects;
5. Funding of engineering and project personnel to ensure timely design and construction of safety infrastructure;
6. Implementation of programs, including grant applications, that follow the USDOT “Safe System Approach,” including focus on driver safety, safer roads, safer vehicles, safer speeds, and post-crash care;
7. Implementation of adaptive design strategies into the City’s transportation infrastructure; and
8. Such other measures, programs and improvements approved by the City Council and permitted by state law.

B. Appropriations from the Spokane Safe Streets Fund. Funds from the Safe Streets Fund shall be appropriated by the city council as part of the annual city budget and/or pursuant to special budget ordinance. In making appropriations the City Council may consider recommendations of the City of Spokane Transportation Commission and Neighborhood Councils with regard to projects and priorities. When feasible, all appropriations from the Safe Streets Fund shall be approved by the city council no later than April 1 of the year in which such funds are to be encumbered.

C. Minimum Allocation to Specified Census Tracts. Expenditures from the Safe Street Funds shall be consistent with the allocation requirements in RCW 46.63.220 (13)(b) as amended from time to time.

**Section 2.** That Section 16A.64.220 of the Spokane Municipal Code is amended to read:

## Section 16A.64.220 Procedures of Use of Automated Traffic Safety Cameras

The use of automated traffic safety cameras is authorized for issuance of notices of infraction for violations regarding obedience to traffic control devices ~~((for stoplights at two-arterial intersection and school speeding zones and))~~ and speed violations is subject to the following requirements:

A. Use of automated traffic safety cameras is restricted to the following locations:

1. For stoplight violations only, at two-arterial intersections as defined in RCW 46.63.230~~((;))~~;
2. ~~((school speeding))~~ School speed zones~~((;))~~;
3. School walk ~~((areas))~~ zones, as defined in RCW 28A.160.160~~((;))~~;
4. School speed zone, as defined in RCW 46.63.210;
5. Public park speed zones, as defined in RCW ~~((46.63.170, and))~~ 46.63.210;
6. Hospital speed zones, as defined in RCW ~~((46.63.170))~~ 46.63.210;
7. Roadway work zones on city streets, as defined in RCW 46.63.210;
8. State highways within city limits and classified as city streets pursuant to RCW 47.24; and
9. For failure to stop at an activated railroad grade crossing control signal only, at railroad grade crossings.

B. Automated traffic safety cameras may only take pictures of the vehicle and vehicle license plate and only while an infraction is occurring. The picture must not reveal the face of the driver or of passengers in the vehicle.

C. A notice of infraction must be mailed to the registered owner of the vehicle within fourteen days of the violation, or to the renter of a vehicle within fourteen days of establishing the renter's name and address under SMC 16A.64.240(B). The ~~((law enforcement officer issuing the))~~ notice of infraction shall include with it a certificate or facsimile thereof, based upon inspection of photographs, microphotographs, or electronic images produced by an automated traffic safety camera, stating the facts supporting the notice of infraction. This certificate or facsimile is prima facie evidence of the facts contained in it and is admissible in a proceeding charging a violation under this chapter. The photographs, microphotographs or electronic images evidencing the violation must be available for inspection and admission into evidence in a proceeding to adjudicate the liability for the infraction. A person

receiving a notice of infraction based on evidence detected by an automated traffic safety camera may respond to the notice by mail.

- D. The registered owner of a vehicle is responsible for an infraction under SMC 16A.64.270(A) unless the registered owner overcomes the presumption in SMC 16A.64.270(B), or, in the case of a rental car business, satisfies the conditions under SMC 16A.64.240(B). If appropriate under the circumstances, a renter identified under SMC 16A.64.240(B)(1) is responsible for an infraction.
- E. Pursuant to RCW ((46.63.170(1)(f))) 46.63.160(6)(6), notwithstanding any other provision of law, all photographs, microphotographs, or electronic images prepared under this section are for the exclusive use of law enforcement in the discharge of duties under this section and are not open to the public and may not be used in a court in a pending action or proceeding unless the action or proceeding relates to a violation under this section. No photograph, microphotograph or electronic image may be used for any purpose other than enforcement of violations under this section nor retained longer than necessary to enforce this section.
- F. All locations where an automated traffic safety camera is used must be clearly marked by placing signs in locations that clearly indicate to a driver that ((he)) the driver is entering a zone where traffic laws are enforced by an automated traffic safety camera. Signage in public park speed zones and hospital speed zones shall conform to the requirements in RCW ((46.63.170)) 46.63.220.

**Section 3.** That Section 16A.64.240 of the Spokane Municipal Code is amended to read:

#### Section 16A.64.240 Notice and Disposition of Traffic Infractions

- A. Infractions detected through the use of automated traffic safety cameras are not part of the registered owner's driving record under RCW 46.52.101 and RCW 46.52.120. Additionally, infractions and resulting penalties generated by the use of automated traffic safety cameras under this section shall be processed in the same manner as parking infractions((, (including for the purposes of)) under state law, including, but not limited to RCW 3.46.120, RCW 3.50.100, RCW 35.20.220, RCW ((46.16.216)) 46.16A.120, ((and)) RCW 46.20.270(3), RCW 46.63.110, RCW 46.63.190, and RCW 46.63.220, as they may be amended from time to time . ((A notice of infraction for stoplight and school speed zone violations detected through the use of automated traffic safety cameras shall result in a fine equal to the total penalty, including the base penalty plus any statutory assessments authorized under state law, for such violations otherwise detected by a police officer.))



- B. If the registered owner of the vehicle is a rental car business, the police department shall, before a notice of infraction being issued under this section, provide a written notice to the rental car business that a notice of infraction may be issued to the rental car business if the rental car business does not, within eighteen days of receiving the written notice, provide to the police department by return mail:
1. a statement under oath stating the name and known mailing address of the individual driving or renting the vehicle when the infraction occurred; or
  2. a statement under oath that the business is unable to determine who was driving or renting the vehicle at the time the infraction occurred; or
  3. in lieu of identifying the vehicle operator, the rental car business may pay the applicable penalty.

Timely mailing of this statement to the police department relieves a rental car business of any liability under this section for the notice of infraction.

- C. Nothing in this section prohibits a law enforcement officer from issuing a notice of traffic infraction at the time a violation occurs to a person in control of a vehicle under the Washington Model Traffic Ordinance.

- D. Except as provided in this subsection, registered owners of vehicles who receive notices of infraction for automated traffic safety camera-enforced infractions and are recipients of public assistance under Title 74 RCW or participants in the Washington women, infants, and children program, and who request reduced penalties for infractions detected through the use of automated traffic safety camera violations, must be granted reduced penalty amounts of 50 percent of what would otherwise be assessed for a first automated traffic safety camera violation and for subsequent automated traffic safety camera violations issued within 21 days of issuance of the first automated traffic safety camera violation. Eligibility for Medicaid under RCW 74.09.510 is not a qualifying criterion under this subsection. Registered owners of vehicles who receive notices of infraction must be provided with information on their eligibility and the opportunity to apply for a reduction in penalty amounts through the mail or internet.

**Section 4.** Section 16A.64.260 of the Spokane Municipal Code is repealed.

**Section 5.** Severability. If any section, subsection, sentence, clause, phrase or word of this ordinance should be held to be invalid or unconstitutional by a court of competent jurisdiction, such invalidity or unconstitutionality thereof shall not affect the validity or constitutionality of any other section, subsection, sentence, clause, phrase or word of this ordinance.

**Section 6. Clerical Errors.** Upon approval by the city attorney, the city clerk is authorized to make necessary corrections to this ordinance, including scrivener's errors or clerical mistakes; references to other local, state, or federal laws, rules, or regulations; or numbering or referencing of ordinances or their sections and subsections.

**PASSED** by the City Council on \_\_\_\_\_

\_\_\_\_\_  
Council President

Attest:

Approved as to form:

\_\_\_\_\_  
City Clerk

\_\_\_\_\_  
Assistant City Attorney

\_\_\_\_\_  
Mayor

\_\_\_\_\_  
Date

\_\_\_\_\_  
Effective Date

**Agenda Sheet for City Council:****Committee:** PIES **Date:** 10/21/2024**Committee Agenda type:** Consent**Date Rec'd**

10/22/2024

**Clerk's File #**

ORD C36602

**Cross Ref #****Project #****Council Meeting Date:** 11/04/2024**Submitting Dept**

WASTEWATER MANAGEMENT

**Bid #****Contact Name/Phone**

RAYLENE 625.7901

**Requisition #****Contact E-Mail**

RGENNETT@SPOKANECITY.ORG

**Agenda Item Type**

First Reading Ordinance

**Council Sponsor(s)**

BWILKERSON JBINGLE KKLITZKE

**Agenda Item Name**

4320 ORDINANCE AMENDMENT SMC 13.03

**Agenda Wording**

Pretreatment Ordinance Amendment - Wastewater Management SMC 13.03

**Summary (Background)**

Amendments to SMC 13.03 regarding requirements for grease control devices, oil/water separators, and sand traps within the City's sewer service area. The goal of these proposed edits is to reduce instances of City sewer pipe obstruction and costly cleanups. These changes have been coordinated with Spokane County, and include new definitions for grease and yellow grease, and clarifications to grease discharges and grease control device maintenance requirements.

Lease? NO

Grant related? NO

Public Works? NO

**Fiscal Impact**

Approved in Current Year Budget? N/A

Total Cost

\$

Current Year Cost

\$

Subsequent Year(s) Cost

\$

**Narrative****Amount****Budget Account**

Select

\$

#

Select

\$

#

Select

\$

#

Select

\$

#

\$

#

\$

#



# Continuation of Wording, Summary, Approvals, and Distribution

## Agenda Wording

## Summary (Background)

<b>Approvals</b>		<b>Additional Approvals</b>	
<u>Dept Head</u>	GENNETT, RAYLENE		
<u>Division Director</u>	FEIST, MARLENE		
<u>Accounting Manager</u>	ALBIN-MOORE, ANGELA		
<u>Legal</u>	SCHOEDEL, ELIZABETH		
<u>For the Mayor</u>	PICCOLO, MIKE		

## **Distribution List**

	hbarnhart@spokanecity.org
kkeck@spokanecity.org	mmurray@spokanecity.org
Tax & Licenses	atagnani@spokanecity.org

## Committee Agenda Sheet

### Public Infrastructure, Environment & Sustainability Committee

<b>Committee Date</b>	October 21, 2024
<b>Submitting Department</b>	Wastewater Management/RPWRP
<b>Contact Name</b>	Raylene Gennett
<b>Contact Email &amp; Phone</b>	<a href="mailto:rgennett@spokanecity.org">rgennett@spokanecity.org</a>
<b>Council Sponsor(s)</b>	CP Wilkerson, CM Bingle, CM Klitzke
<b>Select Agenda Item Type</b>	<input checked="" type="checkbox"/> Consent <input type="checkbox"/> Discussion    Time Requested:
<b>Agenda Item Name</b>	Sewer Ordinance Amendments – Wastewater Management
<b>Proposed Council Action</b>	<input checked="" type="checkbox"/> Approval to proceed to Legislative Agenda <input type="checkbox"/> Information Only
<b>Summary (Background)</b>  *use the Fiscal Impact box below for relevant financial information	<p>Amendments to SMC 13.03 regarding requirements for grease control devices, oil/water separators, and sand traps within the City’s sewer service area. The goal of these proposed edits is to reduce instances of City sewer pipe obstruction and costly cleanups.</p> <p>These changes have been coordinated with Spokane County, and include new definitions for grease and yellow grease, and clarifications to grease discharges and grease control device maintenance requirements.</p>
<p><b>Fiscal Impact</b></p> <p><b>Approved in current year budget?</b>    <input type="checkbox"/> Yes    <input type="checkbox"/> No    <input checked="" type="checkbox"/> N/A</p> <p>Total Cost: <a href="#">Click or tap here to enter text.</a></p> <p>Current year cost:</p> <p>Subsequent year(s) cost:</p> <p><b>Narrative:</b> Please provide financial due diligence review, as applicable, such as number and type of positions, grant match requirements, summary type details (personnel, maintenance and supplies, capital, revenue), impact on rates, fees, or future shared revenue</p> <p><b>Funding Source</b>    <input type="checkbox"/> One-time    <input type="checkbox"/> Recurring    <input checked="" type="checkbox"/> N/A</p> <p>Specify funding source: <a href="#">Select Funding Source*</a></p> <p>Is this funding source sustainable for future years, months, etc? <a href="#">Click or tap here to enter text.</a></p> <p><b>Expense Occurrence</b>    <input type="checkbox"/> One-time    <input type="checkbox"/> Recurring    <input checked="" type="checkbox"/> N/A</p> <p>Other budget impacts: (revenue generating, match requirements, etc.)</p>	
<p><b>Operations Impacts</b> (If N/A, please give a brief description as to why)</p> <ul style="list-style-type: none"> <li>• What impacts would the proposal have on historically excluded communities? Public works services and projects are designed to serve all citizens and businesses. We strive to offer a consistent level of service to all, to distribute public investment throughout the community and to respond to gaps in services identified in various City plans.</li> <li>• How will data be collected, analyzed, and reported concerning the effect of the program/policy by racial, ethnic, gender identity, national origin, income level, disability, sexual orientation, or other existing disparities? N/A</li> </ul>	

- How will data be collected regarding the effectiveness of this program, policy, or product to ensure it is the right solution?

Public Works follows the City's established procurement and public works bidding regulations and policies to bring items forward, and then uses contract management best practices to ensure desired outcomes and regulatory compliance.

- Describe how this proposal aligns with current City Policies, including the Comprehensive Plan, Sustainability Action Plan, Capital Improvement Program, Neighborhood Master Plans, Council Resolutions, and others?

This work is consistent with annual budget strategies to limit costs and approved projects in the 6-year CIP.

### **Council Subcommittee Review**

- Please provide a summary of council subcommittee review. If not reviewed by a council subcommittee, please explain why not.

ORDINANCE NO. C36602

AN ORDINANCE relating to sewers, amending SMC section 13.03.0508; adopting new sections 13.03.0125, 13.03.0225, and 13.03.0501, to chapter 13.03 of the Spokane Municipal Code; and setting an effective date.

The City of Spokane does ordain:

Section 1: That there is adopted a new section 13.03.0125 to chapter 13.03 SMC to read as follows:

**13.03.0125 – Grease**

"Grease" means liquid or other waste containing floatable and/or dispersed grease, vegetable oil, petroleum oil, non-biodegradable cutting oil, fat, oil or grease products of animal, or vegetable or mineral origin which is detectable and measurable in wastewater.

Section 2: That there is adopted a new section 13.03.0225 to chapter 13.03 SMC to read as follows:

**13.03.0225 – Yellow Grease**

A. "Yellow grease" means grease, which is associated with food preparation or processing that has not been contaminated with wash water or chemicals. Common examples include used cooking and fryer oils.

Section 3: That there is adopted a new section 13.03.0501 to chapter 13.03 SMC to read as follows:

**13.03.0501 – Grease Prohibitions**

- A. No user shall discharge, cause, or allow any grease or wastewater containing grease from a facility into the sanitary sewer system. Any wastewater containing grease must be processed through a grease control device prior to discharge.
- B. No user shall discharge, cause, or allow any yellow grease, or any waste or material mixed with yellow grease, into the sanitary sewer system from a facility.
- C. No user shall allow yellow grease from a facility to be mixed with grease control device waste.

Section 4: That SMC section 13.03.0508 is amended to read as follows:

**13.03.0508- Grease Control Devices, Oil/water Separators, Sand Traps—  
Maintenance**

A. All grease control devices, oil/water separators, and sand traps shall be maintained by the owner, at his or her expense and liability, in good order and condition at all

times. Existing grease control devices connected to public sewer shall be, cleaned, inspected, and adequately documented per Subsection C. If the grease control device, oil/water separator, or sand trap fails the inspection as not being up to City standards, such device will have to be repaired or replaced at the owner's expense.

B. Grease control devices, oil/water separators, and sand traps shall be cleaned on a sufficient frequency to prevent objectionable odors, surcharge of the grease control device, obstruction, or interference with the operation of the sanitary sewer system. All devices must be maintained as described below, or in a manner and frequency consistent with manufacturer specifications and guidance.

1. Hydromechanical grease interceptors shall be cleaned at least once every thirty days, or when the device is filled to twenty-five percent or more of capacity with grease or settled solids, whichever comes first. (~~or based on the operational thresholds of the device manufacturer~~).
2. Gravity grease interceptors shall be cleaned by a wastewater hauler at least once every ninety days, or when (~~their~~) the last chamber is filled to twenty-five percent or more of capacity with grease or settled solids, whichever comes first. Grease interceptors with a sample box shall be cleaned immediately when grease is evident in the sample box.
3. Mechanical grease removal devices must be maintained in a manner and frequency consistent with manufacturer specifications and guidance.
4. Oil/water separators and sand traps shall be serviced by a licensed (~~hazardous~~) waste disposal company when the (~~inlet chamber~~) sediment in the bottom of the device exceeds six inches in depth (~~of sludge accumulation~~), when accumulated trash or debris is observed, or when there is one inch or more of floating oil (~~in either chamber~~), whichever comes first.
5. Grease control devices and oil/water separators shall be cleaned by being pumped dry and all accumulated sludge on all surfaces shall be removed by washing down the sides, baffles, and tees. Water removed during cleaning shall not be returned to the grease control device or the oil/water separator, nor the downstream sewer.
6. The use of chemical or biological additives, enzymes or surfactants acting as grease emulsifiers is not permitted as a method for cleaning the grease control device.

C. Users shall maintain records on site for a period of at least three years as follows:



1. Users with an installed grease control device or oil/water separator shall maintain records showing that the control device has been properly maintained and cleaned as required by Subsections A and B.
  2. Users shall maintain records showing the following related to all wastes hauled off site: date and time material removed off site; volume removed; licensed wastewater hauler or hazardous waste disposal company name.
- D. Grease control devices shall be kept free of inorganic solid materials, such as grit, rocks, gravel, sand, eating utensils, cigarettes, shells, towels, rags, etc.
- E. The director may grant an exception to the requirements of Subsections B.2 where the director finds, based on evidence presented by the user, that a less frequent cleaning schedule will be sufficient to assure that not more than twenty-five percent of the capacity of the grease control device will be filled with grease or settled solids.
- F. The director may conduct an inspection of grease control devices, sand traps, and oil/water separators. The user shall make all facilities accessible for inspection, and shall provide inspection and maintenance records. The cost of the inspections, any repairs to the public sewer, and any cleaning of the public sewer, necessitated by a lack of proper maintenance of the user's facilities, shall be billed as an additional utility service to the user.

Section 5. Effective Date. This ordinance shall take effect and be in force on \_\_\_\_\_, 2025.

PASSED BY THE CITY COUNCIL ON \_\_\_\_\_

\_\_\_\_\_  
Council President

Attest:  
  
\_\_\_\_\_  
City Clerk

Approved as to form:  
  
\_\_\_\_\_  
Assistant City Attorney

\_\_\_\_\_  
Mayor

\_\_\_\_\_  
Date

\_\_\_\_\_  
Effective Date

**In Section 1, strike the proposed new SMC Section 15.06.020 and insert the following in its place:**

**15.06.020 Definitions**

- A. "Deconstruction" means the systematic dismantling of a structure, typically in the opposite order it was constructed, in order to maximize the salvage of materials for reuse, in preference over salvaging materials for recycling, energy recovery, sending the materials to a landfill or the City's Waste-to-Energy Facility.
- B. "Demolition" means the complete or partial removal of a structure from a site.
- C. "Period of Deconstruction" means the period beginning on the date the City issues a demolition permit with deconstruction requirements and ending on the date the City's Historic Preservation Office approves the Post-Deconstruction Form.
- D. "Post-Deconstruction Form" means an inventory of materials salvaged for reuse or for donation, as well as materials disposed of by landfill or through the Waste-to-Energy Facility, completed after the deconstruction is complete.
- E. "Pre-Deconstruction Form" means a salvage plan which includes an inventory of materials to be salvaged for reuse or donation as part of a demolition permit requiring deconstruction.
- F. "Recycling" means the processing of waste materials into new products or material feedstock for products. Materials that can be recycled include but are not limited to concrete, bricks, metal piping, and asphalt roofing shingles.
- G. "Reuse" means the utilization of a product or material that was previously installed for the same or similar function to extend its life cycle. Materials salvageable for reuse include but are not limited to cabinets, doors, hardware, fixtures, flooring, siding, windows, and framing lumber.
- H. "Structure" means any building meeting the qualifications of SMC 15.06.030A.
- I. "Relocation" means an alternative option to demolition that does not significantly change, destroy, or adversely affect the historic structure.

**PURPOSE OF AMENDMENT:** Adds subsection "I" which provides a definition of "Relocation."

**Strike the title of the ordinance and substitute the following in its place:**

An ordinance titled the “Mary’s Place Preservation Law,” regulating the preservation of salvageable material; amending section 08.02.031 of the Spokane Municipal Code; and adopting a new chapter 15.06 to Title 15 of the Spokane Municipal Code.

**PURPOSE OF AMENDMENT:** This amendment changes the title to the ordinance include a reference to the demolition of Mary’s Place.

**Agenda Sheet for City Council:****Committee:** Urban Experience **Date:** 10/14/2024**Committee Agenda type:** Discussion**Date Rec'd**

10/1/2024

**Clerk's File #**

ORD C36596

**Cross Ref #****Project #****Council Meeting Date:** 10/28/2024**Submitting Dept**

PLANNING &amp; ECONOMIC

**Bid #****Contact Name/Phone**

JACKIE X6986

**Requisition #****Contact E-Mail**

JCHURCHILL@SPOKANECITY.ORG

**Agenda Item Type**

First Reading Ordinance

**Council Sponsor(s)**

JBINGLE ZZAPPONE KKLITZKE

**Agenda Item Name**

0650 - SB 5290 LAND USE APPLICATION CODE UPDATES

**Agenda Wording**

The proposed draft code amendments have been developed to update Land Use Application permitting requirements in accordance with Senate Bill 5290.

**Summary (Background)**

In 2023 State Legislature passed Senate Bill 5290 which mandates various updates to the Local Project Review Act in order to improve permitting processes. These updates include clarification on the determination of completeness procedural requirements, new permitting deadlines, and mitigation measures to prevent the City from missing the deadline. These updates amend various sections of Chapter 17G Land Use Application Procedures of the Spokane Municipal Code.

Lease? NO

Grant related? NO

Public Works? NO

**Fiscal Impact**

Approved in Current Year Budget? N/A

Total Cost \$ 0

Current Year Cost \$ 0

Subsequent Year(s) Cost \$ 0

**Narrative**

These code updates are state mandated and are procedural in nature affecting 17G Land Use Application Procedures in the SMC. The only associated cost is staff time.

**Amount****Budget Account**

Neutral \$

#

Select \$

#

Select \$

#

Select \$

#

Select \$

#

Select \$

#



# Continuation of Wording, Summary, Approvals, and Distribution

## Agenda Wording

## Summary (Background)

The effective date for these updates is January 1, 2025. Proposed amendments to Section 17G.061.120 Determination of a Complete Application comply with section 6 of Senate Bill 5290 and updates to RCW36.70B.070, which require that the determination of completeness procedural requirements be based solely on the completion of the procedural requirements as listed in the project permit application. Draft changes also clarify the City deadlines and mandates that communication to the applicant must be written. In addition, Sections 17A.020.030 "C" Definitions, Section 17A.020.200 "T" Definitions, are amended to add definitions for "Counter Complete" and "Technically Complete" in order to clarify how these terms relate to state terminology. Continued on Briefing Paper.

### **Approvals**

<b><u>Dept Head</u></b>	GARDNER, SPENCER
<b><u>Division Director</u></b>	GARDNER, SPENCER
<b><u>Accounting Manager</u></b>	ORLOB, KIMBERLY
<b><u>Legal</u></b>	SCHOEDEL, ELIZABETH
<b><u>For the Mayor</u></b>	PICCOLO, MIKE

### **Additional Approvals**

### **Distribution List**

	smacdonald@spokanecity.org
sgardner@spokanecity.org	tblack@spokanecity.org
tthompson@spokanecity.org	jchurchill@spokanecity.org
amccall@spokanecity.org	

## Committee Agenda Sheet

### Urban Experience Committee

<b>Committee Date</b>	October, 14, 2024
<b>Submitting Department</b>	Planning and Economic Development
<b>Contact Name</b>	Jackie Churchill
<b>Contact Email &amp; Phone</b>	<a href="mailto:jchurchill@spokanecity.org">jchurchill@spokanecity.org</a> , ext. 6986
<b>Council Sponsor(s)</b>	Council Members Zappone, Bingle, and Klitzke
<b>Select Agenda Item Type</b>	<input type="checkbox"/> Consent <input checked="" type="checkbox"/> Discussion    Time Requested: 10 min.
<b>Agenda Item Name</b>	SB5290 Land Use Application Procedures Code Updates
<b>Proposed Council Action</b>	<input checked="" type="checkbox"/> Approval to proceed to Legislative Agenda <input type="checkbox"/> Information Only
<b>Summary (Background)</b>  *use the Fiscal Impact box below for relevant financial information	<p>In 2023 State Legislature passed Senate Bill 5290 which mandates various updates to the Local Project Review Act in order to improve permitting processes.</p> <p>These updates include clarification on the determination of completeness procedural requirements, new permitting deadlines, and mitigation measures to prevent the City from missing the deadline. These updates amend various sections of Chapter 17G Land Use Application Procedures of the Spokane Municipal Code. The effective date for these updates is January 1, 2025. Proposed amendments to Section 17G.061.120 Determination of a Complete Application comply with section 6 of Senate Bill 5290 and updates to RCW36.70B.070, which require that the determination of completeness procedural requirements be based solely on the completion of the procedural requirements as listed in the project permit application. Draft changes also clarify the City deadlines and mandates that communication to the applicant must be written. In addition, Sections 17A.020.030 "C" Definitions, Section 17A.020.200 "T" Definitions, are amended to add definitions for "Counter Complete" and "Technically Complete" in order to clarify how these terms relate to state terminology.</p> <p>Proposed amendments to Section 17G.061.130 Application Time Limits and 17G.061.150 Modification of Applications and Permits comply with SB 5290 Section 7 and updates to 36.70B.080, which create new permitting time periods that are dependent upon the type of Land Use permit that is being applied for. Exceptions to the time periods have also been proposed in these sections.</p> <p>The proposed amendments to Section 17G.061.110 Application Requirements, Section 17G.080.040 Short Subdivisions, Section 17G.080.060 Binding Site Plan, Section 17E.020.080 Application Submittal Requirements, Section 17E.030.060 Establishment of Development Permit, Section 17E.040.080 Application Submittal Requirements, Section 17E.070.080 Application Submittal Requirements, comply with section 8 of SB 5290 and updates to RCW 36.70B.160 which mandate that local governments adopt additional measures in lieu of refunding permitting fees if the permitting time periods are missed. These proposed amendments would change Pre-development meetings from "required" to "recommended".</p>

**Fiscal Impact**

**Approved in current year budget?**     Yes     No     N/A

Total Cost: 0

Current year cost: 0

Subsequent year(s) cost: 0

**Narrative:** These code updates are state mandated and are procedural in nature affecting 17G Land Use Application Procedures in the SMC. The only associated cost is staff time.

**Funding Source**             One-time     Recurring     N/A

Specify funding source: Select Funding Source\*

Is this funding source sustainable for future years, months, etc? N/A

**Expense Occurrence**     One-time     Recurring     N/A

Other budget impacts: (revenue generating, match requirements, etc.)

**Operations Impacts** (If N/A, please give a brief description as to why)

What impacts would the proposal have on historically excluded communities?

N/A, Any impacts should be positive in nature as these text amendments are improving and expediting the permitting process in all communities.

How will data be collected, analyzed, and reported concerning the effect of the program/policy by racial, ethnic, gender identity, national origin, income level, disability, sexual orientation, or other existing disparities?

N/A, this is a State mandated change.

How will data be collected regarding the effectiveness of this program, policy or product to ensure it is the right solution?

This is a State mandated change; however, permit applications are tracked through Accela and City Staff will monitor individual applications to ensure timeliness of completion and compliance with state mandated time periods.

Describe how this proposal aligns with current City Policies, including the Comprehensive Plan, Sustainability Action Plan, Capital Improvement Program, Neighborhood Master Plans, Council Resolutions, and others?

The draft amendments have been proposed in order to make updates to the Chapter 17G.061 Land Use Application Procedures code in compliance with the 2023 Senate Bill 5290. SB 5290 updated the Local Project Review Act RCW 36.70B and amended various sections including RCWs 36.70B.070, 36.70B.080, and 36.70B.160. Corresponding sections of the Unified Development Code have been updated to comply with changes to the amended RCWs.

This proposal aligns with Comprehensive Plan Economic Development policy 7.6 which states that the city should, *“Periodically evaluate and improve the City of Spokane’s development standards and permitting process to ensure that they are equitable, cost-effective, timely, and meet community needs and goals”*

Additionally, consistency with Senate Bill 5290 is a requirement on the Periodic Update Checklist for Fully-Planning Cities and advances our work on the required Periodic Update to the Comprehensive Plan 2026 and the required development code amendments.

## ORDINANCE NO C36596

An Ordinance amending Title 17 of the Spokane Municipal Code to update land use application procedures which clarify, expedite, and consolidate the land use permitting process in accordance with Senate Bill 5290. Specifically amending Section 17A.020.030 "C" Definitions, Section 17A.020.200 "T" Definitions, Section 17E.020.080 Application Submittal Requirements, Section 17E.030.060 Establishment of Development Permit, Section 17E.040.080 Application Submittal Requirements, Section 17E.070.080 Application Submittal Requirements, Section 17G.061.110 Application Requirements, Section 17G.061.120 Determination of a Complete Application, Section 17G.061.130 Application Time Limits, Section 17G.061.150 Modification of Applications and Permits, Section 17G.080.040 Short Subdivisions, Section 17G.080.060 Binding Site Plan, setting an effective date, and other matters properly related thereto.

**WHEREAS** the City of Spokane adopted a Comprehensive Plan in May of 2001 that complies with the requirements of the Growth Management Act (GMA) as set forth in RCW 36.70A; and,

**WHEREAS** the Comprehensive Plan includes policies and goals to evaluate and improve the permitting process to ensure that they meet community needs and goals, especially Economic Development policy 7.6 Development Standards and Permitting Process; and,

**WHEREAS**, the State Legislature passed Senate Bill 5290 which amends RCW 36.70B.140, 36.70B.020, 36.70B.070, 36.70B.080, and 36.70B.160, and 36.70B.110, and adds new sections to chapter 36.70B which relate to the consolidating the permitting process,

**WHEREAS**, compliance with Senate Bill 5290 is a requirement on the Periodic Update Checklist for Fully-Planning Cities and advances our work on the required Periodic Update to the Comprehensive Plan 2026 and the required development code amendments.

**WHEREAS**, the City has complied with the amendments to RCW 36.70B.140, 36.70B.020, 36.70B.070, 36.70B.080, and 36.70B.160, and 36.70B.110 in the adoption of this Ordinance,

**WHEREAS**, a SEPA Categorical Exemption WAC 197-11-800(19) applies to SMC Section 17A.020.030 "C" Definitions, Section 17A.020.200 "T" Definitions, Section 17E.020.080 Application Submittal Requirements, Section 17E.030.060 Establishment of Development Permit, Section 17E.040.080 Application Submittal Requirements, Section 17E.070.080 Application Submittal Requirements, Section 17G.061.110 Application Requirements, Section 17G.061.120 Determination of a Complete Application, Section 17G.061.130 Application Time Limits, Section 17G.061.150 Modification of Applications and Permits, Section 17G.080.040 Short Subdivisions, Section 17G.080.060 Binding Site Plan



**WHEREAS**, prior to the Plan Commission public hearing a legal notice was published in the Spokesman Review on September 11, 2024, and September 18, 2024; and,

**WHEREAS**, on September 25, 2024, the Plan Commission held a public hearing on the proposed amendments. No testimony was heard; and,

**WHEREAS**, the City Council adopts the recitals set forth herein as its findings and conclusions in support of the adoption of this ordinance and further adopts the findings, conclusions, and recommendations from the Planning and Economic Development Staff Report and the City of Spokane Plan Commission Findings of Fact, Conclusions, and Recommendations for the same purposes; and

Now, Therefore, the City of Spokane does hereby ordain as follows:

Section 1. Section 17A.020.030 “C” Definitions is amended to read as follows:

A. Candidate Species.

A species of fish or wildlife, which is being reviewed, for possible classification as threatened or endangered.

B. Carport.

A carport is a garage not entirely enclosed on all sides by sight-obscuring walls and/or doors.

C. Cellular Telecommunications Facility.

They consist of the equipment and structures involved in receiving telecommunication or radio signals from mobile radio communications sources and transmitting those signals to a central switching computer that connects the mobile unit with the land-based telephone lines.

D. Central Business District.

The general phrase “central business district” refers to the area designated on the comprehensive plan as the “downtown” and includes all of the area encompassed by all of the downtown zoning categories combined.

E. Certificate of Appropriateness.

Written authorization issued by the commission or its designee permitting an alteration or significant change to the controlled features of a landmark or landmark site after its nomination has been approved by the commission.

F. Certificate of Capacity.

A document issued by the planning and economic development services department indicating the quantity of capacity for each concurrency facility that has been reserved for a specific development project on a specific property. The document may have conditions and an expiration date associated with it.

G. Certified Erosion and Sediment Control Lead (CESCL).

An individual who is knowledgeable in the principles and practices of erosion and sediment control. The CESCL shall have the skills to assess the:

1. site conditions and construction activities that could impact the quality of stormwater, and
2. effectiveness of erosion and sediment control measures used to control the quality of stormwater discharges.

The CESCL shall have current certification through an approved erosion and sediment control training program that meets the minimum training standards established by the Washington State department of ecology.

H. Change of Use.

For purposes of modification of a preliminary plat, "change of use" shall mean a change in the proposed use of lots (e.g., residential to commercial).

I. Channel Migration Zone (CMZ).

A corridor of variable width that includes the current river plus adjacent area through which the channel has migrated or is likely to migrate within a given timeframe, usually one hundred years.

J. Channelization.

The straightening, relocation, deepening, or lining of stream channels, including construction of continuous revetments or levees for the purpose of preventing gradual, natural meander progression.

K. City.

The City of Spokane, Washington.

L. City Engineer.

The Director of the Engineering Services department, or their designee for approval authority.

M. Clear Street Width.

The width of a street from curb to curb minus the width of on-street parking lanes.

N. Clear Pedestrian Zone.

Area reserved for pedestrian traffic; typically included herein as a portion of overall sidewalk width to be kept clear of obstructions to foot traffic.

O. Clear View Triangle.

1. A clear view maintained within a triangular space at the corner of a lot so that it does not obstruct the view of travelers upon the streets.

KEEP CURRENT IMAGE

2. Intersection of local and arterial: A right triangle having a fifteen-foot side measured along the curb line of the residential street and a seventy-five foot side along the curb line of the intersecting arterial street, except that when the arterial street has a speed limit of thirty-five miles per hour, the triangle has a side along such arterial of one hundred twenty-two feet, or when the arterial speed limit is 40 mph or greater the dimensions of the triangle shall be determined by Street Department staff using AASHTO's A Policy on Geometric Design as a reference.

KEEP CURRENT IMAGE

3. Alleys: A right isosceles triangle having sides of seven feet measured along the right-of-way line of an alley and:

- a. the inside line of the sidewalk; or
- b. if there is no sidewalk, a line seven feet inside the curb line.

KEEP CURRENT IMAGE

P. Clear Zone.

The roadside area free of obstacles, starting at the edge of the traveled way.

Q. Clearing.

The removal of vegetation or plant cover by manual, chemical, or mechanical means. Clearing includes, but is not limited to, actions such as cutting, felling, thinning, flooding, killing, poisoning, girdling, uprooting, or burning.

R. Cliffs.

A type of habitat in the Washington department of fish and wildlife (WDFW) priority habitat and species system that is considered a priority due to its limited availability, unique species

usage, and significance as breeding habitat. Cliffs are greater than twenty-five feet high and below five thousand feet elevation.

A "cliff" is a steep slope of earth materials, or near vertical rock exposure. Cliffs are categorized as erosion landforms due to the processes of erosion and weathering that produce them. Structural cliffs may form as the result of fault displacement or the resistance of a cap rock to uniform downcutting. Erosional cliffs form along shorelines or valley walls where the most extensive erosion takes place at the base of the slope.

S. Closed Record Appeal Hearing.

A hearing, conducted by a single hearing body or officer authorized to conduct such hearings, that relies on the existing record created during a quasi-judicial hearing on the application. No new testimony or submission of new evidence and information is allowed.

T. Collector Arterial.

Collector arterials (consisting of Major and Minor Collectors) collect and distribute traffic from local streets to principal and minor arterials. They serve both land access and traffic circulation.

U. Co-location.

Is the locating of wireless communications equipment from more than one provider on one structure at one site.

V. Colony.

A hive and its equipment and appurtenances, including one queen, bees, comb, honey, pollen, and brood.

W. Commercial Driveway.

Any driveway access to a public street other than one serving a single-family or duplex residence on a single lot.

X. Commercial Vehicle.

Any vehicle the principal use of which is the transportation of commodities, merchandise, produce, freight, animals, or passengers for hire.

Y. Commission – Historic Landmarks.

The City/County historic landmarks commission.

## Z. Community Banner.

See SMC 17C.240.015.

## AA. Community Meeting.

An informal meeting, workshop, or other public meeting to obtain comments from the public or other agencies on a proposed project permit prior to the submission of an application.

A community meeting is between an applicant and owners, residents of property in the immediate vicinity of the site of a proposed project, the public, and any registered neighborhood organization or community council responsible for the geographic area containing the site of the proposal, conducted prior to the submission of an application to the City of Spokane.

A community meeting does not constitute an open record hearing.

The proceedings at a community meeting may be recorded and a report or recommendation shall be included in the permit application file.

## AB. Compensatory Mitigation.

Replacing project-induced wetland losses or impacts, and includes, but is not limited to, the following:

### 1. Restoration.

The manipulation of the physical, chemical, or biological characteristics of a site with the goal of returning natural or historic functions to a former or degraded wetland. For the purpose of tracking net gains in wetland acres, restoration is divided into re-establishment and rehabilitation.

### 2. Re-establishment.

The manipulation of the physical, chemical, or biological characteristics of a site with the goal of returning natural or historic functions to a former wetland. Re-establishment results in a gain in wetland acres (and functions). Activities could include removing fill material, plugging ditches, or breaking drain tiles.

### 3. Rehabilitation.

The manipulation of the physical, chemical, or biological characteristics of a site with the goal of repairing natural or historic functions of a degraded wetland. Rehabilitation results in a gain in wetland function but does not result in a gain in wetland acres. Activities could involve breaching a dike to reconnect wetlands to a floodplain or return tidal influence to a wetland.

### 4. Creation (Establishment).

The manipulations of the physical, chemical, or biological characteristics present to develop a wetland on an upland or deepwater site where a wetland did not previously exist.

Establishment results in a gain in wetland acres. Activities typically involve excavation of upland soils to elevations that will produce a wetland hydroperiod, create hydric soils, and support the growth of hydrophytic plant species.

#### 5. Enhancement.

The manipulation of the physical, chemical, or biological characteristics of a wetland site to heighten, intensify, or improve specific function(s) or to change the growth stage or composition of the vegetation present. Enhancement is undertaken for specified purposes such as water quality improvement, flood water retention, or wildlife habitat. Enhancement results in a change in some wetland functions and can lead to a decline in other wetland functions, but does not result in a gain in wetland acres. Activities typically consist of planting vegetation, controlling non-native or invasive species, modifying site elevations or the proportion of open water to influence hydroperiods, or some combination of these activities.

#### 6. Protection/Maintenance (Preservation).

Removing a threat to, or preventing the decline of, wetland conditions by an action in or near a wetland. This includes the purchase of land or easements, repairing water control structures or fences or structural protection such as repairing a barrier island. This term also includes activities commonly associated with the term preservation. Preservation does not result in a gain of wetland acres, may result in a gain in functions, and will be used only in exceptional circumstances.

#### AC. Counter Complete

A land use application is counter complete if the application contains the documents and information required by SMC 17G.061.110 and required fees have been paid. This is the first step in the Land Use Application Determination of Completeness as outlined in 17G.061.120 and the department may request additional information, documents, or studies before certifying the application as technically complete.

#### ~~((AG))~~ AD. Comprehensive Plan.

The City of Spokane comprehensive plan, a document adopted pursuant to chapter 36.70A RCW providing land use designations, goals and policies regarding land use, housing, capital facilities, housing, transportation, and utilities.

#### ~~((AD))~~ AE. Conceptual Landscape Plan.

A scale drawing showing the same information as a general site plan plus the location, type, size, and width of landscape areas as required by the provisions of chapter 17C.200 SMC.

The type of landscaping, L1, L2, or L3, is required to be labeled.

It is not a requirement to designate the scientific name of plant materials on the conceptual landscape plan.

((AE)) AF. Concurrency Certificate.

A certificate or letter from a department or agency that is responsible for a determination of the adequacy of facilities to serve a proposed development, pursuant to chapter 17D.010 SMC, Concurrency Certification.

((AF)) AG. Concurrency Facilities.

Facilities for which concurrency is required in accordance with the provisions of this chapter. They are:

1. transportation,
2. public water,
3. fire protection,
4. police protection,
5. parks and recreation,
6. libraries,
7. solid waste disposal and recycling,
8. schools, and
9. public wastewater (sewer and stormwater).

((AG)) AH. Concurrency Test.

The comparison of an applicant's impact on concurrency facilities to the available capacity for public water, public wastewater (sewer and stormwater), solid waste disposal and recycling, and planned capacity for transportation, fire protection, police protection, schools, parks and recreation, and libraries as required in SMC 17D.010.020.

((AH)) AI. Conditional Use Permit.

A "conditional use permit" and a "special permit" are the same type of permit application for purposes of administration of this title.

((AI)) AJ. Condominium.

Real property, portions of which are designated for separate ownership and the remainder of which is designated for common ownership solely by the owners of those portions. Real property is not a condominium unless the undivided interests in the common elements are vested in unit owners, and unless a declaration and a survey map and plans have been recorded pursuant to chapter 64.34 RCW.

((AJ)) AK. Confidential Shelter.

Shelters for victims of domestic violence, as defined and regulated in chapter 70.123 RCW and WAC 248-554. Such facilities are characterized by a need for confidentiality.

((AK)) AL. Congregate Residence.

A dwelling unit in which rooms or lodging, with or without meals, are provided for nine or more non-transient persons not constituting a single household, excluding single-family residences for which special or reasonable accommodation has been granted.

((AL)) AM. Conservancy Environments.

Those areas designated as the most environmentally sensitive and requiring the most protection in the current shoreline master program or as hereafter amended.

((AM)) AN. Container.

Any vessel of sixty gallons or less in capacity used for transporting or storing critical materials.

((AN)) AO. Context Areas

Established by the Regulating Plan, Context Area designations describe and direct differing functions and features for areas within FBC limits, implementing community goals for the built environment.

((AO)) AP. Contributing Resource

Contributing resource is any building, object, structure, or site which adds to the historical integrity, architectural quality, or historical significance of the local or federal historic district within which the contributing resource is located.

((AP)) AQ. Conveyance.

In the context of chapter 17D.090 SMC or chapter 17D.060 SMC, this term means a mechanism for transporting water from one point to another, including pipes, ditches, and channels.

((AQ)) AR. Conveyance System.

In the context of chapter 17D.090 SMC or chapter 17D.060 SMC, this term means the drainage facilities and features, both natural and constructed, which collect, contain and provide for the flow of surface and stormwater from the highest points on the land down to receiving water. The natural elements of the conveyance system include swales and small drainage courses,



streams, rivers, lakes, and wetlands. The constructed elements of the conveyance system include gutters, ditches, pipes, channels, and most flow control and water quality treatment facilities.

~~((AR))~~ AS. Copy.

See SMC 17C.240.015.

~~((AS))~~ AT. Cottage Housing.

A grouping of residential units with a common open space.

~~((AT))~~ AU. Council.

The city council of the City of Spokane.

~~((AU))~~ AV. County.

Usually capitalized, means the entity of local government or, usually not capitalized, means the geographic area of the county, not including the territory of incorporated cities and towns.

~~((AV))~~ AW. Courtyard apartments.

Three or more attached dwelling units arranged on two or three sides of a yard or court.

~~((AW))~~ AX. Covenants, Conditions, and Restrictions (CC&Rs).

A document setting forth the covenants, conditions, and restrictions applicable to a development, recorded with the Spokane County auditor and, typically, enforced by a property owner's association or other legal entity.

~~((AX))~~ AY. Creep.

Slow, downslope movement of the layer of loose rock and soil resting on bedrock due to gravity.

~~((AY))~~ AZ. Critical Amount.

The quantity component of the definition of critical material.

~~((AZ))~~ BA. Critical Aquifer Recharge Areas (CARA).

Critical aquifer recharge areas (CARA) include locally identified aquifer sensitive areas (ASA) and wellhead protection areas.

((BA)) BB. Critical Areas.

Any areas of frequent flooding, geologic hazard, fish and wildlife habitat, aquifer sensitive areas, or wetlands as defined under chapter 17E.010 SMC, chapter 17E.020 SMC, chapter 17E.030 SMC, chapter 17E.040 SMC, and chapter 17E.070.SMC.

((BB)) BC. Critical Facility.

A facility for which even a slight chance of flooding might be too great. Critical facilities include, but are not limited to:

1. schools;
2. nursing homes;
3. hospitals;
4. police;
5. fire;
6. emergency response installations; and
7. installations which produce, use, or store hazardous materials or hazardous waste.

((BC)) BD. Critical Material.

1. A compound or substance, or class thereof, designated by the division director of public works and utilities which, by intentional or accidental release into the aquifer or ASA, could result in the impairment of one or more of the beneficial uses of aquifer water and/or impair aquifer water quality indicator levels. Beneficial uses include, but are not limited to:

- a. domestic and industrial water supply,
- b. agricultural irrigation,
- c. stock water, and
- d. fish propagation.

Used herein, the designation is distinguished from state or other designation.

2. A list of critical materials is contained in the Critical Materials Handbook, including any City modifications thereto.

((BD)) BE. Critical Material Activity.

A land use or other activity designated by the manager of engineering services as involving or likely to involve critical materials. A list of critical materials activities is contained in the Critical Materials Handbook.

((BE)) BF. Critical Materials Handbook.

The latest edition of a publication as approved and amended by the division director of public works and utilities from time to time to accomplish the purposes of this chapter.

1. The handbook is based on the original prepared by the Spokane water quality management program ("208") coordination office, with the assistance of its technical advisory committee. It is on file with the director of engineering services and available for public inspection and purchase.
2. The handbook, as approved and modified by the division director of public works and utilities, contains:
  - a. a critical materials list,
  - b. a critical materials activities list, and
  - c. other technical specifications and information.
3. The handbook is incorporated herein by reference. Its provisions are deemed regulations authorized hereunder and a mandatory part of this chapter.

((BF)) BG. Critical Review.

The process of evaluating a land use permit request or other activity to determine whether critical materials or critical materials activities are involved and, if so, to determine what appropriate measures should be required for protection of the aquifer and/or implementation of the Spokane aquifer water quality management plan.

((BG)) BH. Critical Review Action.

1. An action by a municipal official or body upon an application as follows:
  - a. Application for a building permit where plans and specifications are required, except for Group R and M occupancies (SMC 17G.010.140 and SMC 17G.010.150).
  - b. Application for a shoreline substantial development permit (SMC 17G.061.070(B)(1)).
  - c. Application for a certificate of occupancy (SMC 17G.010.170).
  - d. Application for a variance or a certificate of compliance SMC 17G.061.110.
  - e. Application for rezoning SMC 17G.061.110.
  - f. Application for conditional permit SMC 17G.061.110.
  - g. Application for a business license (SMC 8.01.120).
  - h. Application for a permit under the Fire Code (SMC 17F.080.060).
  - i. Application for a permit or approval requiring environmental review in an environmentally sensitive area (SMC 17E.050.260).
  - j. Application for connection to the City sewer or water system.
  - k. Application for construction or continuing use of an onsite sewage disposal system (SMC 13.03.0149 and SMC 13.03.0304).

- l. Application for sewer service with non-conforming or non-standard sewage (SMC 13.03.0145, SMC 13.03.0314, and SMC 13.03.0324).
- m. Application involving a project identified in SMC 17E.010.120.
- n. Issuance or renewal of franchise; franchisee use of cathodic protection also requires approval or a franchise affecting the City water supply or water system.
- o. Application for an underground storage tank permit (SMC 17E.010.210); and
- p. Application for permit to install or retrofit aboveground storage tank(s) (SMC 17E.010.060(A) and SMC 17E.010.400(D)).

2. Where a particular municipal action is requested involving a land use installation or other activity, and where said action is not specified as a critical review action, the City official or body responsible for approval may, considering the objectives of this chapter, designate such as a critical review action and condition its approval upon compliance with the result thereof.

((BH)) BI. Critical Review Applicant.

A person or entity seeking a critical review action.

((BI)) BJ. Critical Review Officer – Authority.

- 1. The building official or other official designated by the director of public works and utilities.
- 2. For matters relating to the fire code, the critical review officer is the fire official.
- 3. The critical review officer carries out and enforces the provisions of this chapter and may issue administrative and interpretive rulings.
- 4. The critical review officer imposes requirements based upon this chapter, regulations, and the critical materials handbook.
- 5. The officer may adopt or add to any requirement or grant specific exemptions, where deemed reasonably necessary, considering the purpose of this chapter.

((BJ)) BK. Critical Review Statement.

A checklist, disclosure form, or part of an application for a critical review action, disclosing the result of critical review. Where not otherwise provided as part of the application process, the critical review officer may provide forms and a time and place to file the statement.

((BK)) BL. Cumulative Impacts.

The combined, incremental effects of human activity on ecological or critical area functions and values. Cumulative impacts result when the effects of an action are added to or interact with other effects in a particular place and within a particular time. It is the combination of these effects, and any resulting environmental degradation, that should be the focus of cumulative impact analysis and changes to policies and permitting decisions.

((BL)) BM. Curb Ramp.

A ramp constructed in the sidewalk to provide an accessible route from the sidewalk to the street.

((BM)) BN. Cutbank.

The concave bank of a moving body of water that is maintained as a steep or even overhanging cliff by the actions of water at its base.

Section 2. Section 17A.020.200 "T" Definitions SMC is amended to read as follows:

A. Technically Complete

A term to describe a land use application that is certified as complete. A land use application will be deemed technically complete once all steps in 17G.061.120 Land Use Application Procedures for Determination of Completeness have been satisfied and all requested information has been correctly submitted to the City. This definition applies to applications determined procedurally complete as defined by RCW 36.70B.070.

((A)) B. Temporary Erosion and Sediment Control Measures.

Erosion and sediment control devices used to provide temporary stabilization of a site, usually during construction or ground disturbing activities, before permanent devices are installed.

((B)) C. Temporary Sign.

A sign placed on a structure or the ground for a specifically limited period of time as provided in SMC 17C.240.240(G).

((G)) D. Temporary Structure.

A structure approved for location on a lot by the department for a period not to exceed six months with the intent to remove such structure after the time period expires.

((D)) E. Tenant Space.

Portion of a structure occupied by a single commercial lease holder with its own public entrance from the exterior of the building or through a shared lobby, atrium, mall, or hallway and separated from other tenant spaces by walls.

((E)) F. Through Pedestrian Zone.

The portion of a sidewalk that is intended for pedestrian travel and is entirely free of permanent and temporary objects.

((F)) G. Tideland.

Land on the shore of marine water bodies between the line of ordinary high tide and the line of extreme low tide.

((G)) H. Total Maximum Daily Load (TMDL).

A calculation of the maximum amount of a pollutant that a water body can receive and still meet water quality standards, and an allocation of that amount to the pollutant's sources. A TMDL is the sum of the allowable loads of a single pollutant from all contributing point and non point sources. The calculation shall include a margin of safety to ensure that the water body can be used for the purposes the state has designated. The calculation shall also account for reasonable variation in water quality. Water quality standards are set by states, territories, and tribes. They identify the uses for each water body, for example, drinking water supply, contact recreation (swimming), and aquatic life support (fishing), and the scientific criteria to support that use. The Clean Water Act, section 303, establishes the water quality standards and TMDL programs.

((H)) I. [Deleted].

((I)) J. [Deleted].

((J)) K. [Deleted].

((K)) L. Tracking.

The deposition of sediment onto paved surfaces from the wheels of vehicles.

((L)) M. Tract.

A piece of land created and designated as part of a land division that is not a lot, lot of record or a public right-of-way. Tracts are created and designated for a specific purpose. Land uses within a tract are restricted to those uses consistent with the stated purpose as described on the plat, in maintenance agreements, or through conditions, covenants and restrictions (CC&Rs).

((M)) N. Traveled Way.

The area of street which is intended to carry vehicular traffic, excluding any shoulders.

((N)) O. Triplex.

A building that contains three dwelling units on the same lot that share a common wall or common floor/ceiling.

((O)) P. Type I Application.

An application for a project permit that is subject to an administrative approval and is not categorically exempt from environmental review under chapter 43.21C RCW (SEPA) and the

City of Spokane Environmental Ordinance chapter 17E.050 SMC, and does not require a public hearing. Type I applications are identified in Table 17G.061.010-1 in chapter 17G.061 SMC. These applications may include, but are not limited to, building permits and grading permits.

((P)) Q. Type II Application.

An application for a project permit that is subject to an administrative decision of a department director, that may or may not be categorically exempt from chapter 43.21C RCW (SEPA), and does not require a public hearing. The Type II applications are identified in Table 17G.061.010-1 in chapter 17G.061 SMC. These applications may include, but are not limited to, short plats, binding site plans, shoreline substantial development permits, and some conditional use permits; provided, the planning director may require conditional use permits which are otherwise characterized as Type II applications under this title to be submitted and processed as Type III applications when the director issues written findings that the Type III process is in the public interest.

((Q)) R. Type III Application.

An application for a project permit that is subject to a quasi-judicial decision of the hearing examiner that may or may not be categorically exempt from chapter 43.21C RCW (SEPA) and the City of Spokane Environmental Ordinance chapter 17E.050 SMC and requires a public hearing. Type III applications are identified in Table 17G.061.010-1 in chapter 17G.061 SMC. These applications may include, but are not limited to, rezones, conditional use permits, preliminary long plats, or shoreline conditional use permits.

Section 3: Section 17E.020.080 Application Submittal Requirements is amended to read as follows:

- A. A pre-development conference is recommended ((required)) for all regulated activities proposed in potential fish and wildlife habitat conservation areas and associated buffers per [chapter 17G.061 SMC](#). The pre-development conference is intended to acquaint an applicant with standards, requirements, investigation procedures, best management practice and potential review procedures prior to making application.
- B. A critical areas checklist is required at the time of application for all regulated activities proposed in fish and wildlife habitat areas and associated buffers per [SMC 17G.061.110\(C\)](#).
- C. All activities identified in [SMC 17E.020.050](#) shall meet the following application submittal requirements in addition to the application submittal requirements specified in other codes. The director may modify the submittal requirements based upon reasonable documentation, including BAS, needed to ensure compliance with this chapter, provided no construction activity, clearing or grading has taken place. A written summary of analysis and findings shall be included in any staff report or decision on the underlying permit.

1. Topographic Survey.

A topographic site plan, prepared and stamped by a State of Washington licensed surveyor, is required for sites that include a wetland or its buffer. The

- a. Existing topography at two-foot contour intervals on-site, on adjacent lands within twenty-five feet of the site's property lines, and on the full width of abutting public and private rights-of-way and easements.
- b. Terrain and stormwater-flow characteristics within the site, on adjacent sites within twenty-five feet of the site's property lines, and on the full width of abutting public and private rights-of-way and easements.
- c. Location of areas with significant amounts of vegetation, and specific location and description of all trees with trunks six inches or greater in diameter measured four feet, six inches above the ground, and noting their species.
- d. Location and boundaries of all existing site improvements on the site, on adjacent lands within twenty-five feet of the site's property lines, and on the full width of abutting public and private rights-of-way and easements. This shall include the amounts of developmental coverage, including all impervious surfaces (noting total square footage and percentage of site occupied).
- e. Location of all grading activities in progress, and all natural and artificial drainage control facilities or systems in existence or on adjacent lands on the site, within twenty-five feet of the site's property lines, and in the full width of abutting public and private rights-of-way and easements.
- f. Location of all existing utilities (water, sewer, gas, electric, phone, cable, etc.), both above and below ground, on the site, on adjacent lands within twenty-five feet of the site's property lines and in the full width of abutting public rights-of-way; and
- g. Such additional existing physical elements information for the site and surrounding area as required by the director to complete review of a project subject to the standards of this chapter.

## 2. Additional Site Plan Information.

The following site plan information shall also be required for sites that include landslide-prone, flood-prone, riparian corridor, wetland and steep slope areas or their buffers. Information related to the location and boundaries of critical areas and required buffer delineations shall be prepared by qualified professionals with training and experience in their respective area of expertise as demonstrated to the satisfaction of the director.

- a. Location and boundaries of all critical areas and related buffers on the site and on adjacent lands within twenty-five feet of the site's property lines, noting both total square footage and percentage of site.



- b. Location and identification of all riparian corridors and wetlands within one hundred feet of the site's property lines.
- c. Location and boundaries of all proposed site improvements on the site, on adjacent lands within twenty-five feet of the site's property lines, and on the full width of abutting public and private rights-of-way and easements. This shall include the amount of proposed land disturbing activities, including amounts of developmental coverage, impervious surfaces and construction activity areas (noting total square footage and percentage of site occupied).
- d. Location of all proposed grading activities and all proposed drainage control facilities or systems on the site or on adjacent lands within twenty-five feet of the site's property lines, and on the full width of abutting public and private rights-of-way and easements.
- e. Location of all proposed utilities (water, sewer, gas, electric, phone, cable, etc.), both above and below ground, on the site, on adjacent lands within twenty-five feet of the site's property lines, in the full width of abutting public rights-of-way, and any proposed extension required to connect to existing utilities, and proposed methods and locations for the proposed development to hook-up to these services; and
- f. Such additional site plan information related to the proposed development as required by the director to complete review of a project subject to the standards of this chapter.

### 3. Technical Reports.

Technical reports and other studies and submittals shall be prepared as required by the director detailing soils, geological, hydrological, drainage, plant ecology and botany, and other pertinent site information. The reports, studies and submittals shall be used to condition development to prevent potential harm and to protect the critical nature of the site, adjacent properties and the drainage basin.

Section 4: Section 17E.030.060 Establishment of Development Permit is amended to read as follows:

#### A. Development Permit Required.

A development permit shall be obtained before construction or development begins within any area of special flood hazard established in [SMC 17E.030.050\(B\)](#). The permit shall be for all structures including manufactured homes, as defined in [chapter 17A.020 SMC](#) and for all development, including fill and other activities also as defined in [chapter 17A.020 SMC](#).

#### B. A pre-development conference as set forth in [chapter 17G.061 SMC](#) is recommended ((required)) for all development proposed in areas identified as potential critical areas within the City of Spokane, including areas of special flood hazard established in [SMC 17E.030.050\(B\)](#).

#### C. Application for Floodplain Development Permit.

Application for a floodplain development permit shall be made on forms furnished by the City and may include, but not be limited to, plans in duplicate drawn to scale showing the nature, location, dimensions and elevations of the area in question: existing or proposed structures, fill, storage of materials, drainage facilities and the location of foregoing. Specifically, the following information is required:

1. Elevation in relation to mean sea level, of the lowest floor (including basement) of all structures recorded on a current elevation certificate with Section B completed by the Floodplain Administrator;
2. Elevation in relation to mean sea level to which any structure has been floodproofed;
3. Where a structure is to be floodproofed, certification by a registered professional engineer or architect that the floodproofing methods for any nonresidential structure meet the floodproofing criteria in [SMC 17E.030.130](#);
4. Description of the extent to which a watercourse will be altered or relocated as a result of proposed development;
5. A completed critical areas checklist as established at [chapter 17G.061 SMC](#);
6. A completed environmental checklist, unless the Floodplain Administrator as designated in [SMC 17E.030.070](#) has determined that the project is categorically exempt from [chapter 17E.050 SMC](#);
7. Where development is proposed in a floodway, an engineering analysis indicating no rise of the Base Flood Elevation; and
8. Any other such information that may be reasonably required by the Floodplain Administrator in order to review the application, including all studies, reports and information required by reviewing departments or agencies to fully disclose potential environmental impacts of the proposal. These studies are required to demonstrate acceptance by the applicable department or agencies prior to the application being certified complete.

D. Fee Processing.

Floodplain development permits shall be processed as set forth in [chapter 17G.061 SMC](#).

E. Fee Schedule.

The fees for processing a floodplain development permit are set forth in [SMC 8.02.066\(F\)](#).

Section 5: Section 17E.040.080 Application Submittal Requirements is amended to read as follows:

- A. A pre-development conference is recommended ((required)) for all regulated activities proposed in geologically hazardous areas and associated buffers per [chapter 17G.061 SMC](#). The pre-development conference is intended to acquaint an applicant with standards, requirements, investigation procedures, best management practice and potential review procedures prior to making application.

- B. All activities identified in [SMC 17E.040.050](#) shall meet the following application submittal requirements in addition to the application submittal requirements specified in other codes. The director may modify the submittal requirements based upon reasonable documentation, including BAS, needed to ensure compliance with this chapter, provided no construction activity, clearing or grading has taken place. A written summary of analysis and findings shall be included in any staff report or decision on the underlying permit.

1. Topographic Survey.

A topographic site plan, prepared and stamped by a State of Washington licensed surveyor, is required for sites that include a geohazard or its buffer. The topographic site plan shall include the following existing physical elements:

- a. Existing topography at two-foot contour intervals on-site, on adjacent lands within twenty-five feet of the site's property lines, and on the full width of abutting public and private rights-of-way and easements.
- b. Terrain and stormwater-flow characteristics within the site, on adjacent sites within twenty-five feet of the site's property lines, and on the full width of abutting public and private rights-of-way and easements.
- c. Location of areas with significant amounts of vegetation, and specific location and description of all trees with trunks six inches or greater in diameter measured four feet, six inches above the ground, and noting their species.
- d. Location and boundaries of all existing site improvements on the site, on adjacent lands within twenty-five feet of the site's property lines, and on the full width of abutting public and private rights-of-way and easements. This shall include the amounts of developmental coverage, including all impervious surfaces (noting total square footage and percentage of site occupied).
- e. Location of all grading activities in progress, and all natural and artificial drainage control facilities or systems in existence or on adjacent lands on the site, within twenty-five feet of the site's property lines, and in the full width of abutting public and private rights-of-way and easements.
- f. Location of all existing utilities (water, sewer, gas, electric, phone, cable, etc.), both above and below ground, on the site, on adjacent lands within twenty-five feet of the site's property lines and in the full width of abutting public rights-of-way; and
- g. Such additional existing physical elements information for the site and surrounding area as required by the director to complete review of a project subject to the standards of this chapter.

2. Additional Site Plan Information.

The following site plan information shall also be required for sites that include landslide-prone, flood-prone, riparian corridor, wetland and steep slope areas or their buffers. Information related to the location and boundaries of critical areas and

required buffer delineations shall be prepared by qualified professionals with training and experience in their respective area of expertise as demonstrated to the satisfaction of the director.

- a. Location and boundaries of all critical areas and related buffers on the site and on adjacent lands within twenty-five feet of the site's property lines, noting both total square footage and percentage of site.
- b. Location and identification of all riparian corridors and wetlands within one hundred feet of the site's property lines.
- c. Location and boundaries of all proposed site improvements on the site, on adjacent lands within twenty-five feet of the site's property lines, and on the full width of abutting public and private rights-of-way and easements. This shall include the amount of proposed land disturbing activities, including amounts of developmental coverage, impervious surfaces and construction activity areas (noting total square footage and percentage of site occupied).
- d. Location of all proposed grading activities and all proposed drainage control facilities or systems on the site or on adjacent lands within twenty-five feet of the site's property lines, and on the full width of abutting public and private rights-of-way and easements.
- e. Location of all proposed utilities (water, sewer, gas, electric, phone, cable, etc.), both above and below ground, on the site, on adjacent lands within twenty-five feet of the site's property lines, in the full width of abutting public rights-of-way, and any proposed extension required to connect to existing utilities, and proposed methods and locations for the proposed development to hook-up to these services; and
- f. Such additional site plan information related to the proposed development as required by the director to complete review of a project subject to the standards of this chapter.

### 3. Technical Reports.

Technical reports and other studies and submittals, including the geohazard evaluation and mitigation plan described in [SMC 17E.040.090](#) below, shall be prepared as required by the director detailing soils, geological, hydrological, drainage, plant ecology and botany, and other pertinent site information. The reports, studies and submittals shall be used to condition development to prevent potential harm and to protect the critical nature of the site, adjacent properties and the drainage basin.

Section 6: Section 17E.070.080 Application Submittal Requirements is amended to read as follows:

- A. A pre-development conference is ((required)) recommended for all regulated activities proposed in potential wetland areas and associated buffers per [chapter 17G.061 SMC](#). The pre-development conference is intended to acquaint an applicant with standards,

requirements, investigation procedures, best management practice, and potential review procedures prior to submitting an application.

- B. All activities identified in [SMC 17E.070.040](#) shall meet the following application submittal requirements in addition to the application submittal requirements specified in other codes. The director may modify the submittal requirements based upon reasonable documentation, including BAS, needed to ensure compliance with this chapter, provided no construction activity, clearing, or grading has taken place. A written summary of analysis and findings shall be included in any staff report or decision on the underlying permit.
1. Wetlands Report. This report shall include a written assessment and accompanying maps of the impacted wetland including, at a minimum, wetland delineation and rating as determined by [SMC 17E.070.100](#); existing wetland acreage; proposed wetland impacts; alternatives to wetlands impacts; proposed wetland buffer; vegetative, faunal and hydrological characteristics; soil and substrate conditions and topographic elevations; and shall be submitted as a part of the permit application.
  2. Topographic Survey. To the extent not provided in the wetlands report, a topographic site plan, prepared and stamped by a State of Washington licensed surveyor, is required for sites that include a wetland or its buffer. The topographic site plan shall include the following existing physical elements:
    - a. Existing topography at two-foot contour intervals on-site, on adjacent lands within twenty-five feet of the site's property lines, and on the full width of abutting public and private rights-of-way and easements;
    - b. Terrain and stormwater-flow characteristics within the site, on adjacent sites within twenty-five feet of the site's property lines, and on the full width of abutting public and private rights-of-way and easements;
    - c. Location of areas with significant amounts of vegetation, and specific location and description of all trees with trunks six inches or greater in diameter at breast height (dbh) measured four feet, six inches above the ground, and noting their species;
    - d. Location and boundaries of all existing site improvements on the site, on adjacent lands within twenty-five feet of the site's property lines, and on the full width of abutting public and private rights-of-way and easements. This shall include the amounts of developmental coverage, including all impervious surfaces (noting total square footage and percentage of site occupied);
    - e. Location of all ongoing grading activities as well as all natural and artificial drainage control facilities or systems in existence on the site or on adjacent lands, within twenty-five feet of the site's property lines, and in the full width of abutting public and private rights-of-way and easements;
    - f. Location of all existing utilities (water, sewer, gas, electric, phone, cable, etc.), both above and below ground, on the site, on adjacent lands within twenty-five feet of the site's property lines and in the full width of abutting public rights-of-way; and
    - g. Additional information on existing physical elements on the site and surrounding area as required by the director to inform a complete review of a project subject to the standards of this chapter.
  3. Additional Site Plan Information. To the extent not provided in the wetlands report, the following site plan information shall also be required for sites that include wetlands and their buffers. Information related to the location and boundaries of wetlands and required buffer delineations shall be prepared by qualified professionals with training and experience in their respective area of expertise as demonstrated to the satisfaction of the director.

- a. Location and boundaries of all wetlands and wetland buffer on the site and on adjacent lands within twenty-five feet of the site's property lines, noting both total square footage and percentage of site;
  - b. Location and identification of all wetlands within one hundred feet of the site's property lines;
  - c. Location and boundaries of all proposed site improvements on the site, on adjacent lands within twenty-five feet of the site's property lines, and on the full width of abutting public and private rights-of-way and easements. This shall include the amount of proposed land disturbing activities, including amounts of developmental coverage, impervious surfaces and construction activity areas (noting total square footage and percentage of site occupied);
  - d. Location of all proposed grading activities and all proposed drainage control facilities or systems on the site or on adjacent lands within twenty-five feet of the site's property lines, and on the full width of abutting public and private rights-of-way and easements;
  - e. Location of all proposed utilities (water, sewer, gas, electric, phone, cable, etc.), both above and below ground, on the site, on adjacent lands within twenty-five feet of the site's property lines, in the full width of abutting public rights-of-way, and any proposed extension required to connect to existing utilities, and proposed methods and locations for the proposed development to hook-up to these services; and
  - f. Such additional site plan information related to the proposed development as required by the director to inform a complete review of a project subject to the standards of this chapter.
4. Technical Reports. To the extent not provided in the wetlands report, technical reports and other studies and submittals shall be prepared as required by the director detailing on site soils, geology, hydrology, drainage, plant ecology and botany, and other pertinent site information. The reports, studies and submittals shall be used to condition development to prevent potential harm and to protect the critical nature of the site, adjacent properties, and the drainage basin.

Section 7: Section 17G.061.110 Application Requirements is amended to read as follows:

A. Predevelopment Meeting.

1. Purpose.

Predevelopment meetings are not intended to be an exhaustive review of all regulations or potential issues for a given application. Predevelopment meetings have two purposes:

- a. acquaint City staff and other agencies with a proposed development and to generally advise the applicant of applicable regulations, design guidelines and design review processes, and policies impacting the proposal; and
  - b. acquaint the applicant with the applicable provisions of these procedures, minimum submission requirements and other plans or regulations which may impact the proposal.
2. The City may, when applicable, apply additional relevant laws to the application subsequent to a predevelopment meeting.

3. ~~((Predevelopment meetings are required for any development proposal in the central business district. The Planning Director or Building Official, as appropriate, may waive this requirement.))~~
4. Predevelopment meetings are recommended for Type II and III applications, and Type I project permit applications in the centers and corridors (CC) zones.

#### B. Community Meeting.

All Type III applications and Type II applications where indicated in [Table 17G.061.010-1](#) are required to hold a community meeting regarding the proposed application. The applicant or their representative shall conduct the community meeting.

1. Timing.

The meeting shall occur no more than one hundred twenty days prior to application and before the application is accepted by the City.

2. Notice.

Notice for the community meeting shall be posted fourteen days prior to the meeting. Public notice of a community meeting shall be provided as required in [SMC 17G.061.210](#).

3. Combining with Traffic Study.

When a traffic study is required as a part of an application, the scoping meeting for a traffic study may be combined with the community meeting.

4. Meeting Summary.

The applicant shall provide a summary of the meeting at the time of submission of the application. Other attendees of the community meeting may also submit a summary of the meeting issues to the decision-maker. The meeting summary shall consist of the following:

- a. A digital recording of the meeting proceedings; and
- b. List of attendees; and
- c. A copy of the notice of community meeting; and
- d. Affidavits of posting/ mailing the notice.

#### C. General Requirements.

Applications shall include the following:

1. Predevelopment meeting summary, if required under subsection (A).
2. Filing fees as required under [chapter 8.02 SMC](#).

3. Application documents supplied by the City, including but not limited to:
  - a. General application form;
  - b. Supplemental application form;
  - c. Environmental checklist, if required under [chapter 17E.050 SMC](#);
4. A site plan drawn to scale showing:
  - a. Property dimensions;
  - b. location and dimensions of all existing and proposed physical improvements;
  - c. location and type of landscaping;
  - d. walkways and pedestrian areas;
  - e. off-street parking areas and access drives;
  - f. refuse facilities; and
  - g. significant natural features, such as slopes, trees, rock outcrops, and critical areas.
5. Required copies of documents, plans, or maps (as set forth in the application checklist).
6. Written narrative identifying consistency with the applicable policies, regulations, and criteria for approval of the permit requested.
7. Other plans, such as building elevations, landscaping plans, or sign plans, which are determined by the permitting department to be necessary to support the application.
8. Additional application information as requested by the permitting department, which may include, but is not limited to, the following:
  - a. geotechnical studies;
  - b. hydrologic studies;
  - c. critical area studies;
  - d. noise studies;
  - e. air quality studies;
  - f. visual analysis; and



- g. transportation impact studies.

#### D. Additional Requirements

The following Type II and III applications shall meet these requirements in addition to the provisions of subsection (B) of this section:

1. Shoreline – Substantial Development Permit, Conditional Use Permit and Variance.
  - a. Name, address, and phone number of the applicant. The applicant should be the owner of the property or the primary proponent of the project and not the representative of the owner or primary proponent.
  - b. Name, address, and phone number of the applicant's representative if other than the applicant.
  - c. Name, address, and phone number of the property owner, if other than the applicant.
  - d. Location of the property. This shall, at a minimum, include the property address and identification of the section, township and range to the nearest quarter, quarter section or latitude and longitude to the nearest minute.
  - e. Identification of the name of the shoreline (water body) with which the site of the proposal is associated.
  - f. General description of the proposed project that includes the proposed use or uses and the activities necessary to accomplish the project.
  - g. General description of the property as it now exists, including its physical characteristics and improvements and structures.
  - h. General description of the vicinity of the proposed project, including identification of the adjacent uses, structures and improvements, intensity of development and physical characteristics.
  - i. A site development plan consisting of maps and elevation drawings, drawn to an appropriate scale to depict clearly all required information, photographs and text which shall include:
    - i. the boundary of the parcels(s) of land upon which the development is proposed;
    - ii. the ordinary high-water mark of all water bodies located adjacent to or within the boundary of the project. This may be an approximate location, provided that for any development where a determination of consistency with the applicable regulations requires a precise location of the ordinary high-water mark, the mark shall be located precisely and the biological and hydrological basis for the location as indicated on the plans shall be included in the development plan. Where the ordinary high-water mark is neither adjacent to or within the boundary of the

project, the plan shall indicate the distance and direction to the nearest ordinary high-water mark of a shoreline;

- iii. existing and proposed land contours. The contours shall be at intervals sufficient to accurately determine the existing character of the property and the extent of proposed change to the land that is necessary for the development. Areas within the boundary that will not be altered by the development may be indicated as such and contours approximated for that area;
- iv. a delineation of all wetland areas that will be altered or used as a part of the development;
- v. the dimensions and locations of all existing and proposed structures and improvements, including but not limited to: buildings, paved or graveled areas, roads, utilities, material stockpiles or surcharge, and stormwater management facilities;
- vi. an inventory of the existing vegetation on the proposed project site, including the location, type, size, and condition, pursuant to [SMC 17E.060.240](#), Shoreline Vegetation Inventory;
- vii. a landscape plan prepared and stamped by a licensed landscape architect, registered in the state of Washington;
- viii. where applicable, plans for development of areas on or off the site as mitigation for impacts associated with the proposed project shall be included;
- ix. quality, source and composition of any fill material that is placed on the site, whether temporary or permanent;
- x. quantity, composition and destination of any excavated or dredged material;
- xi. vicinity map showing the relationship of the property and proposed development or use to roads, utilities, existing developments, and uses on adjacent properties;
- xii. where applicable, a depiction of the impacts to views from existing residential uses;
- xiii. on all variance applications, the plans shall clearly indicate where development could occur without the approval of a variance, the physical features and circumstances of the property that provide a basis for the request, and the location of adjacent structures and uses.

## 2. Certificate of Compliance.

- a. Site plan is to be prepared by a licensed surveyor; and

- b. Copies of building permits or other data necessary to demonstrate the building was erected in good faith and all reasonable efforts comply with the code.
3. Plans-in-lieu of Compliance.
  - a. Alternative development plan designed in conformance with the applicable development regulations; and
  - b. A written narrative of how the proposed development plan is superior, or more innovative, or provides greater public benefit.
4. Preliminary Plat, Short Plat, and Binding Site Plan. As provided in [chapter 17G.080 SMC](#).
5. PUD.
  - a. Profiles of any structures more than one story, shown in relation to finished grade.
  - b. Location, dimension, and boundary of proposed open space.
  - c. Site plan demonstrating compliance with Title 17C SMC including signs, off-street parking, structure height, building coverage, yards, density, screening, buffering, and lighting.
6. Skywalk.
  - a. A legal description of airspace to be occupied.
  - b. Architectural and engineering plans.
  - c. Artist's rendering of the proposed skywalk; and
  - d. Written narrative of the access for the public from the street, other buildings, and other skywalks.
  - e. Acceptance of the final design review recommendations.
  - f. Location and design of all wayfinding signage to be placed to ensure public access.
7. Floodplain – Floodplain Development Permit and Variance.

As provided in [chapter 17E.030 SMC](#)

Section 8: Section 17G.061.120 Determination of a Complete Application is amended to read as follows:

**A. Determination of Completeness.**

Within twenty-eight days of receiving a project permit application, the department shall determine if the application is technically complete (RCW 36.70B.070) as outlined on the project

permit application. Additional information or studies may be required, or project modifications may be undertaken subsequent to the technical review of the application by the City.

1. The number of days is measured by counting every calendar day.

2. If a written determination to the contrary is not provided by the 29<sup>th</sup> day, the application shall be deemed technically complete. However, this does not prevent the City from requesting additional information or studies after the application is deemed technically complete.

#### B. Procedures for Determination of Completeness.

The following steps outline the process for the department to determine that an application is complete.

##### 1. Counter Complete.

The department shall conduct a preliminary, immediate review to determine if the application filed with the City contains the documents and information required by SMC 17G.061.110. If the department determines the application does not contain the required documents and information, the application including fees shall be returned to the applicant.

##### 2. Component Screening.

If the application appears to contain required documents, the department shall accept the application and within seven days, conduct a detailed review and determine if any additional information is necessary to process the application. If the department determines the application is missing required components, or is inadequate in other ways, ~~the application including any fees shall be returned to the applicant. the applicant shall be sent a written determination outlining the necessary components that are needed to make the application counter complete.~~

a. If the department issues a second request for corrections or information, staff may schedule a meeting to meet with the applicant to attempt to resolve the outstanding issues. The meeting must be scheduled within 14 days of the second request.

b. If a meeting does not resolve the issues and the department proceeds with a third request for additional information or corrections, the application must be approved or denied upon receiving the additional information or corrections.

##### 3. Review by Interested Agencies.

If the application, after the detailed review, is found to contain the required components and supporting documents, the application and supporting documents shall be forwarded to (i) interested City departments, (ii) agencies of local, state, or federal governments that may have jurisdiction over some aspect of the application, and (iii) the individual(s) designated pursuant to SMC 4.27.010(D) to receive written notice on behalf of the neighborhood council in which the project is located and to any neighborhood council whose geographic boundaries are located within a 600-foot radius of the project, at the address for such departments, agencies, and neighborhood council designee(s) on file with the department, for review to ensure compliance with state laws, ordinances and concurrency requirements. Interested departments, agencies, and the neighborhood council shall be given fourteen days to provide comments on a permit application. All written comments will be forwarded to the applicant at the end of the fourteen day comment period. Comments submitted after the fourteen day comment period will be forwarded to the applicant, subject to RCW 36.70B.070.

~~a. If review agencies require additional information to continue processing the application, the applicant shall be notified in writing.~~

~~b. Required information must be provided within sixty days from the notification by the department. The applicant may submit a written request for additional time to the director; any time extensions shall be in writing. If the information is not~~

~~received within the sixty days (or as otherwise agreed to), the application and a portion of the fees shall be returned to the applicant, pursuant to chapter 8.02 SMC.~~

~~c. Within fourteen days of the submission of the additional information identified by the review agency, the department shall notify the applicant whether the studies are adequate or what additional information is necessary.~~

~~d. If the neighborhood council submits written comments on an application, the department shall provide a written response to the chairperson, with copy to the applicant, no later than the date on which the application is certified complete pursuant to paragraph D herein below.~~

4. a. Application Certified Complete. Certification.

~~Within seven days of the expiration of the interested agency comment period, ((if no additional information was required, or the information required under subsection (3) is acceptable,)) the department shall provide a written determination stating either that the application is technically complete or that the application is technically incomplete. ((certify the application complete. Applications requiring review by the hearing examiner are forwarded to the hearing examiner upon being certified as complete.))~~

~~((a-)) i. If review agencies require additional information to continue processing the application, the applicant shall be notified in writing.~~

~~((b-)) ii. Required information must be provided within sixty days from the notification by the department. The applicant may submit a written request for additional time to the director; any time extensions shall be in writing. If the information is not received within the sixty days (or as otherwise agreed to), the application and a portion of the fees shall be returned to the applicant, pursuant to chapter 8.02 SMC.~~

~~((c-)) iii. Within fourteen days of the submission of the additional information identified by the review agency, the department shall notify the applicant whether the studies are adequate or what additional information is necessary.~~

~~((d-)) iv. If the neighborhood council submits written comments on an application, the department shall provide a written response to the chairperson, with copy to the applicant, no later than the date on which the application is certified complete pursuant to paragraph D herein below.~~

4. Technically Complete Application

1. Within seven days of the expiration of the interested agency comment period, if no additional information was required, or the information required under subsection (3) is acceptable, the department shall provide a written determination stating either that the application is certified as technically complete or still technically incomplete.

5. Notice of Application.

Within fourteen days of the issuance of a determination of a complete application, a notice of application shall be provided for Type I, II and III project permit applications in accordance with this section (RCW 36.70B.110.2), except that notice of application is not required for short subdivision applications involving minor engineering review as defined in SMC 17G.080.040(C)(2). The notice of application shall follow the public notice requirements contained in SMC 17G.061.210. The notice of application may be combined with the notice of public hearing, if a hearing has been scheduled by notice of application. The date, time, place and type of hearing, SEPA determination and SEPA appeal deadline (using the optional DNS process) are required to be added to the notice of application if this provision is used (RCW 36.70B.110(2)(f)).

6. Vesting.

Applications shall be considered vested at the time the application is ~~((certified))~~ counter complete and all fees have been paid, the vesting date shall be the date of application

submission. If the application is not complete when filed or information is not timely provided as set forth in subsection (2) or (3), the application shall not be considered complete for purposes of vesting or other statutory compliance dates.

a. Expiration of Vested applications

1. Vested applications remain in effect unless no action is taken to complete the project and the date of expiration is reached. A list of permit expiration dates can be found in [Table 17G.061.010-1](#).

Section 9: Section 17G.061.130 Application Time Limits is amended to read as follows:

A. A decision on permit applications subject to this chapter shall ((be made within one hundred twenty days of submission of a complete application as set forth in SMC 17G.061.130.)) not exceed the following for each type of permit (RCW 36.70B.080):

1. 65 days for permits which do not require public notice.
2. 100 days for permits which require public notice, and
3. 170 days for permits which require public notice and a public hearing.
4. The number of days is measured by counting every calendar day.
5. A summary of the application types and requirements can be found in [Table 17G.061.010](#).

B. ((The following shall be excluded when calculating this time period:)) The number of days an application is in review with the City shall be calculated from the day the application is deemed technically complete as determined under RCW 36.70B.070 to date a final decision is issued on the project permit application. The number of days shall be calculated by counting every calendar day and excluding the following time periods:

1. Any period during which the applicant has been requested by the department to correct plans, perform required studies, or provide additional required information due to the applicant's inaccurate or insufficient information and the day when additional information is submitted by the applicant.
2. Any period during which an environmental impact statement is being prepared.
3. Any period for administrative appeals of land use permits.
4. ((Any extension for any reasonable period mutually agreed upon in writing between the applicant and the department (RCW 36.70B.080(1)).)) Time periods may be extended for 30 days in the following cases:
  - a. If the applicant informs the City in writing that the applicant would like to suspend the review of the project for more than 60 days; or
  - b. If the applicant is not responsive for more than 60 consecutive days after the additional information has been requested to further process the application.
5. If the permit requires approval of a new fully contained community as provided in RCW 36.70A.350, or a master planned resort as provided in RCW 36.70A.360, or the siting of an essential public facility as provided in RCW 36.70A.200.

6. The time periods shall start over if an applicant proposes a substantial modification to an application as described in Section 17G.061.150 Modification of Applications and Permits.

7. Annual amendments to the comprehensive plan are not subject to the requirements of this section.

C. The City may, by adoption of an ordinance or resolution, modify the time periods to add permit types, change permit names or types in each category, address how consolidated review time frames may be different than permits submitted individually and address how projects of a certain size or type may be differentiated as provided for in RCW 36.70B.140.

Section 10: Section 17G.061.150 Modification of Applications and Permits is amended to read as follows:

A. Modification of Complete Application.

1. Proposed modifications to an application, which the department has previously found to be complete, will be treated as follows:
  - a. Minor ((M)) modifications proposed by the department to an application shall not be considered a new application.
  - b. If the applicant proposes substantial modifications to an application, as determined by the department, the application may be considered a new application. The new application shall conform to the requirements of all statutes and ordinances in effect at the time the new application is submitted. A substantial modification may include but is not limited to the following:
    - i. change in use;
    - ii. increase in density;
    - iii. increase in site area; or
    - iv. changes that increase or significantly modify the traffic pattern for the proposed development.

B. Limitations on Refiling of Application.

1. Applications for a land use permit pursuant to Title 17 SMC on a specific site shall not be accepted if a similar permit has been denied on the site within the twelve months prior to the date of submittal of the application. The date of denial shall be considered the date the decision was made on an appeal, if an appeal was filed or the date of the original decision if no appeal was filed.
2. The twelve-month time period may be waived or modified if the director finds that special circumstances warrant earlier reapplication. The director shall consider the following in determining whether an application for permit is similar to, or substantially the same as, a previously denied application:

- a. An application for a permit shall be deemed similar if the proposed use of the property is the same, or substantially the same, as that which was considered and disallowed in the earlier decision.
- b. An application for a permit shall be deemed similar if the proposed application form and site plan (i.e., building layout, lot configuration, dimensions) are the same, or substantially the same, as that which was considered and disallowed in the earlier decision; and
- c. An application for a variance, exception, or waiver shall be deemed similar if the special circumstances which the applicant alleges as a basis for the request are the same, or substantially the same, as those considered and rejected in the earlier decision. In every instance, the burden of proving that an application is not similar shall be upon the applicant.

### C. Modifications or Revisions to Shoreline Permits.

1. A permit revision is required whenever the applicant proposes substantive changes to the design, terms, or conditions of a project from that which is approved in the permit. Changes are substantive if they materially alter the project in a manner that relates to its conformance to the terms and conditions of the permit, the shoreline master program and/or the policies and provisions of chapter 90.58 RCW.
2. Changes which are not substantive in effect do not require approval of a revision. When an applicant seeks to revise a permit, the director shall request from the applicant detailed plans and text describing the proposed changes in the permit.
3. If the director determines that the proposed changes are within the scope and intent of the original permit as defined in WAC 173-27-100(2) and are consistent with the shoreline master program and the Shoreline Management Act, the director may approve a revision.
4. If the proposed changes are not within the scope and intent of the original permit, the applicant shall apply for a new permit in the manner provided for in this chapter.
5. Revisions to permits may be authorized after original permit authorization has expired under RCW 90.58.143. The purpose of such revisions shall be limited to authorization of changes which are consistent with WAC 173-27 and which would not require a permit for the development or change proposed under the terms of the Shoreline Management Act, this section and the shoreline master program. If the proposed change constitutes substantial development then a new permit is required. This shall not be used to extend the time requirements or to authorize substantial development beyond the time limits of the original permit.
6. If the sum of the revision and any previously approved revisions under former WAC 173-14-064 or WAC 173-27-100 violate the provisions that they are "within the scope and intent of the original permit," the director shall require that the applicant apply for a new permit.
7. The revision approval, including the revised site plans and text consistent with the provisions of WAC 173-27-180 as necessary to clearly indicate the authorized changes, and the final ruling on consistency with this section shall be filed with the



department of ecology. In addition, the director shall notify parties of record of their action.

8. If the revision to the original permit was a conditional use or variance, which was conditioned by the department of ecology, the director shall submit the revision to the department of ecology for its approval, approval with conditions, or denial, indicating that the revision is being submitted under the requirements of this section. Ecology shall render and transmit to the City and the applicant its final decision within fifteen days of the date of the department of ecology's receipt of the submittal from the director. The director shall notify parties of record of the department of ecology's final decision.
9. The revised permit is effective immediately upon final decision by the director, or when reviewed by the department of ecology, pursuant to subsection (7), then upon final action by the department of ecology.
10. Appeals shall be in accordance with RCW 90.58.180 and shall be filed with the shorelines hearings board within twenty-one days from the date of receipt of the revision approved by the director, or when appropriate under subsection (7), the date ecology's final decision is transmitted to the City and the applicant. Appeals shall be based only upon contentions of noncompliance with the provisions of subsection (2). Construction undertaken pursuant to that portion of a revised permit not authorized under the original permit is at the applicant's own risk until the expiration of the appeals deadline. If an appeal is successful in proving that a revision is not within the scope and intent of the original permit, the decision shall have no bearing on the original permit.

#### D. Modification to a Building Permit Subject to a Type II or III Approval.

In issuing building permits for construction under an approved site plan, the building official may, with concurrence of the Planning Director, permit minor adjustments of the location and/or dimensions of buildings, parking areas, and roadways as long as such adjustments do not change any points of ingress or egress to the site unless approved by the director of engineering services, change any perimeter setbacks, or exceed the density authorized in the permit. No modification of an approved application may be considered approved unless specifically provided in writing.

1. The Planning Director may, without public notice, modify an approved site plan, if all the following criteria are met:
  - a. The use will remain the same.
  - b. The total site coverage or total area covered by buildings will not increase.
  - c. The use will continue to comply with all conditions of approval imposed by the original decision.
  - d. The use will comply with all of the requirements of the land use regulations applicable to it and the property on which it is or will be located.

2. Any modification of an approved site plan not consistent with the standards of subsection (B)(1) of this section may be approved only pursuant to the procedures for granting the original Type II or III approval.

#### E. Modification of Shoreline Permit.

##### 1. Rescission and Remanding of Shoreline Permit.

- a. After providing notice to the permittee and the public and also holding a public meeting, the Planning Director may rescind or suspend a permit if any of the conditions in RCW 90.58.140(8) exist.
- b. Under the conditions listed in RCW 90.58.180, shoreline permits may be remanded back to the City by the Shorelines Hearings Board.

##### 2. Other Modification of Shoreline Permit.

- a. A permit revision is required whenever the applicant proposes substantive changes to the design, terms, or conditions of a project from that which is approved in the permit. Changes are substantive if they materially alter the project in a manner that relates to its conformance to the terms and conditions of the permit, the shoreline master program and/or the policies and provisions of chapter 90.58 RCW.
- b. Changes which are not substantive in effect do not require approval of a revision. When an applicant seeks to revise a permit, the director shall request from the applicant detailed plans and text describing the proposed changes in the permit.
- c. If the director determines that the proposed changes are within the scope and intent of the original permit as defined in WAC 173-27-100(2) and are consistent with the shoreline master program and the Shoreline Management Act, the director may approve a revision.
- d. If the proposed changes are not within the scope and intent of the original permit, the applicant shall apply for a new permit in the manner provided for in this chapter.
- e. Revisions to permits may be authorized after original permit authorization has expired under RCW 90.58.143. The purpose of such revisions shall be limited to authorization of changes which are consistent with WAC 173-27 and which would not require a permit for the development or change proposed under the terms of the Shoreline Management Act, this section and the shoreline master program. If the proposed change constitutes substantial development then a new permit is required. This shall not be used to extend the time requirements or to authorize substantial development beyond the time limits of the original permit.
- f. If the sum of the revision and any previously approved revisions under former WAC 173-14-064 or WAC 173-27-100 violate the provisions that they are "within the scope and intent of the original permit," the director shall require that the applicant apply for a new permit.

- g. The revision approval, including the revised site plans and text consistent with the provisions of WAC 173-27-180 as necessary to clearly indicate the authorized changes, and the final ruling on consistency with this section shall be filed with the department of ecology. In addition, the director shall notify parties of record of their action.
- h. If the revision to the original permit was a conditional use or variance, which was conditioned by the department of ecology, the director shall submit the revision to the department of ecology for its approval, approval with conditions, or denial, indicating that the revision is being submitted under the requirements of this section. Ecology shall render and transmit to the City and the applicant its final decision within fifteen days of the date of the department of ecology's receipt of the submittal from the director. The director shall notify parties of record of the department of ecology's final decision.
- i. The revised permit is effective immediately upon final decision by the director, or when reviewed by the department of ecology, pursuant to subsection (7), then upon final action by the department of ecology.
- j. Appeals shall be in accordance with RCW 90.58.180 and shall be filed with the shorelines hearings board within twenty-one days from the date of receipt of the revision approved by the director, or when appropriate under subsection (7), the date ecology's final decision is transmitted to the City and the applicant. Appeals shall be based only upon contentions of noncompliance with the provisions of subsection (2). Construction undertaken pursuant to that portion of a revised permit not authorized under the original permit is at the applicant's own risk until the expiration of the appeals deadline. If an appeal is successful in proving that a revision is not within the scope and intent of the original permit, the decision shall have no bearing on the original permit.

Section 11: Section 17G.080.040 Short Subdivisions is amended to read as follows:

A. Predevelopment Meeting

A predevelopment meeting (~~(is required if the proposal is located in the central business district, unless waived by the director, and))~~ is recommended for all other proposals prior to submittal of the application. The purpose of a predevelopment meeting is to acquaint the applicant with the applicable provisions of this chapter, minimum submission requirements and other plans or regulations, which may impact the proposal.

B. Preliminary Short Plat Application and Map Requirements

- 1. Applications for approval of a preliminary short subdivision shall be filed with the director. All applications shall be submitted on forms provided for such purpose by the department. The director may waive specific submittal requirements determined to be unnecessary for review of the application. The application shall include the following:
  - a. The general application.

- b. The supplemental application.
- c. The environmental checklist, if required under [chapter 17E.050 SMC](#).
- d. Title report no older than thirty days from issuance from the title company.
- e. The filing fees as required under [chapter 8.02 SMC](#).
- f. The required number of documents, plans or maps drawn to a minimum scale of one-inch equals one hundred feet, on a sheet twenty-four by thirty-six inches, as set forth in the application checklist.
- g. A written narrative identifying consistency with the applicable policies, regulations and criteria for approval of the permit requested; and
- h. Additional application information which may be requested by the permitting department and may include, but is not limited to, the following: geotechnical studies, hydrologic studies, critical area studies, noise studies, air quality studies, visual analysis and transportation impact studies.
- i. One copy of the predevelopment conference notes (if applicable); and
- j. One copy of the notification district map.

## 2. Contents of Preliminary Short Plat Map

The preliminary short plat shall be prepared by a land surveyor and shall show the following:

- a. Plat name and the name of any subdivision to be replatted.
- b. The name, mailing address and phone number of the owner and the person with whom official contact should be made regarding the application.
- c. Surveyor's name, mailing address<sub>1</sub> and phone number.
- d. Legal description.
- e. Section, township<sub>1</sub> and rang
- f. Vicinity map.
- g. North arrow, scale and date.
- h. Datum plane.
- i. Acreage.
- j. Number of lots<sub>1</sub> proposed density, and number of housing units.
- k. Zoning designation.

- l. The boundary lines of the proposed subdivision.
- m. City limits and section lines.
- n. Park or open space (if proposed).
- o. Existing topography at two-foot maximum interval.
- p. The boundaries and approximate dimensions of all blocks and lots, along with the following information:
  - i. the numbers proposed to be assigned each lot and block;
  - ii. the dimensions, square footage, and acreage of all proposed lots and tracts; and
  - iii. for residential lots zoned R1 or R2, the proposed Middle Housing types, included single-unit detached houses, and total number of proposed units on all proposed lots.
- q. Proposed names of streets.
- r. The location and widths of streets, alleys, rights-of-way, easements (both public and private), turn around and emergency access, parks and open spaces.
- s. Conditions of adjacent property, platted or unplatted, and if platted, giving the name of the subdivision. If the proposed short plat is the subdivision of a portion of an existing plat, the approximate lines of the existing plat are to be shown along with any and all recorded covenants and easement
- t. The names and address of the record owners and taxpayers of each parcel adjoining the subdivision.
- u. Indicate any street grades in excess of eight percent.
- v. The location and, where ascertainable, sizes of all permanent buildings, wells, wellhead protection areas, sewage disposal systems, water courses, bodies of water, flood zones, culverts, bridges, structures, overhead and underground utilities, railroad lines, and other features existing upon, over or under the land proposed to be subdivided, and identifying any which are to be retained or removed.
- w. Proposed one-foot strips for right-of-way conveyed to the City, in cases where a proposed public street or alley abuts unplatted land.
- x. If a body of water forms the boundary of the plat, the ordinary high water mark as defined in chapter 90.58 RCW.
- y. Critical areas as defined in chapters [17E.020](#), [17E.030](#), [17E.070](#) and [17G.030 SMC](#).

- z. Significant historic, cultural or archaeological resources; and
- aa. If the proposal is located in an irrigation district, the irrigation district name.

#### C. Review of Preliminary Short Plat

1. The application shall be reviewed in accordance with the procedures set forth in chapter 17G.061 SMC for a Type II application, except an application that meets the requirements for minor engineering review as provided in subsection (2) of this section shall be excluded from the public notice requirements contained in SMC 17G.06210 and public comment period under SMC 17G.061.220.
2. Minor Engineering Review.
  - a. A preliminary short plat application may qualify for a Minor Engineering Review if it meets all of the following conditions:
    - i. The application is categorically exempt from chapter 43.21C RCW (SEPA);
    - ii. There is direct water and sewer main lot frontage on an existing and improved public right-of-way;
    - iii. No extensions of public water, sewer, or other utility services will be needed;
    - iv. No public easements for water, sewer, or other utility service exists on the lot;
    - v. The lot is not situated in a Special Drainage District as defined in [SMC 17D.060.130](#); and
    - vi. Public utility mains do not exist on the lot.
  - b. The City Engineer is authorized to waiver conditions ii through vi of the subsection (a) if the application substantially meets the intent of the Minor Engineering Review.

#### D. Public Notice And Public Comment.

All public notice of the application and opportunities for public comment shall be given in accordance with the procedures set forth in [chapter 17G.061 SMC](#) for a Type II application.

1. Exceptions.
  - a. A short plat that meets the requirements of Minor Engineering Review as provided in subsection (C)(2) of this section shall not require a notice of application.
  - b. A short plat that is categorically exempt from SEPA and results in four or fewer lots shall not require a posted or signed notice of application.

#### E. Preliminary Short Plat Approval Criteria

Prior to approval of a short plat application, the director shall find the application to be in the public use and interest, conform to applicable land use controls and the comprehensive plan of the City, and the approval criteria set forth in [chapter 17G.061 SMC](#). The director has the authority to approve or disapprove a proposed preliminary short plat under the provisions of this chapter, subject to appeal as provided in [chapters 17F.050](#) and [17G.061 SMC](#).

#### F. Final Short Plat Review Procedure

1. The subdivider shall submit to the director for review the following:
  - a. A final short plat, prepared by a registered land surveyor licensed in the state of Washington, consistent with the approved preliminary short plat.
  - b. A title report less than thirty days old confirming that the title of the lands as described and shown on said plat is in the name of the owners signing the certificate or instrument of dedication.
  - c. Covenants, conditions and restrictions, if applicable; and
  - d. Fees pursuant to [chapter 8.02 SMC](#).
2. Within thirty days, unless the applicant has consented to a longer period of time, of receipt of a proposed final short plat, the director shall review the plat for conformance with all conditions of the preliminary short plat approval, the requirements of this chapter and that arrangements have been made to insure the construction of required improvements. If all such conditions are met, the director shall approve the final short plat and authorize the recording of the plat. If all conditions are not met, the director shall provide the applicant in writing a statement of the necessary changes to bring the final short plat into conformance with the conditions.
  - a. If the final short plat is required to be resubmitted, the subdivider is required to provide the following:
    - b. A cover letter addressing the corrections, additions or modifications required.
    - c. Title report no older than thirty days from issuance of a title company conforming that the title of the lands as described and shown on said plat is in the name of the owners signing the certificate or instrument of dedication; and
  - d. The required number of copies of the corrected final short plat map.
3. If the final short plat is approved, the surveyor causes the plat to be signed by the Spokane county treasurer and file of record with the Spokane county auditor. The surveyor is required to file the appropriate number of mylar and bond copies of the recorded short plat with the director.

G. Final Short Plat Map Requirements

The subdivider shall submit to the director a final short plat in the same form and with the same content as the preliminary short plat, as provided in subsections (B)(1) and (2) of this section, with the following exceptions or additional requirements:

1. A final short plat shall contain all the information required of the preliminary plat, except the following:
  - a. Show existing buildings.
  - b. Show existing utility lines and underground structures.
  - c. Show the topographical elevations; or
  - d. Contain the names and addresses of adjoining landowners.

2. The final short plat shall include the following:

- a. Surveyor's certificate, stamp, date and signature, as follows:

The following land surveyor's certificate to be shown on each sheet of the plat:  
"I, \_\_\_\_\_ registered land surveyor, hereby certify the plat of \_\_\_\_\_, as shown hereon, is based upon actual field survey of the land described and that all angles, distances, and courses are correctly shown and that all non fronting lot corners are set as shown on the plat. Monuments and fronting lot corners shall be set upon completion of the utility and street improvements.

Signed \_\_\_\_\_(Seal)"

- b. A certification by the city treasurer, as applicable:

- i. "I hereby certify that the land described by this plat, as of the date of this certification, is not subject to any local improvement assessments. Examined and approved, this \_\_\_\_\_ day of \_\_\_\_\_, 20\_\_.

\_\_\_\_\_

City of Spokane Treasurer"

- ii. "I hereby certify that the land described by this plat, as of the date of this certificate, is not subject to any delinquent local improvement assessment. Future installments, if any, shall remain due and payable and it shall be the responsibility of the owners to initiate the segregation of the LID assessment. Examined and approved, this \_\_\_\_\_ day of \_\_\_\_\_, 20\_\_.

\_\_\_\_\_

City of Spokane Treasurer"



- iii. "A preliminary local improvement assessment exists against this property. It shall be the responsibility of the owner's to initiate the segregation of the LID assessment. After this assessment is finalized, it shall be due and payable. Examined and approved this \_\_\_\_\_ day of \_\_\_\_\_, 20\_\_.

\_\_\_\_\_

City of Spokane Treasurer"

- c. The certification by the planning director, as follows:

"This plat has been reviewed on this \_\_\_\_\_ day of \_\_\_\_\_, 20\_\_ and is found to be in full compliance with all the conditions of approval stipulated in the Hearing Examiner's/Planning Director's approval of the preliminary plat # - - PP/SP.

\_\_\_\_\_

City of Spokane Planning Director"

- d. The certification by the city engineer, as follows:

"Approved as to compliance with the survey data, the design of public works and provisions made for constructing the improvements and permanent control monuments this \_\_\_\_\_ day of \_\_\_\_\_, 20\_\_.

\_\_\_\_\_

City of Spokane Engineer"

- e. The certification by the Spokane county treasurer, as follows:

"I hereby certify that the land described in this plat, as of the date of this certification, is not subject to any outstanding fees or assessments. Examined and approved \_\_\_\_\_ day of \_\_\_\_\_, 20\_\_.

\_\_\_\_\_

Spokane County Treasurer"

- f. The certification by the Spokane county auditor on each page of the final short plat including the time, date, book and page number of the recording of the final mylar.

- g. Signature of every owner certifying that:

- i. the plat is made with the free consent and in accordance with the desires of the owners of the land;
- ii. the plat is made with the free consent and in accordance with the desires of the owners of the land;

- iii. the owners are the owners of the property and the only parties having interest in the land and is not encumbered by any delinquent taxes or assessments;
  - iv. the owners adopt the plan of lots, blocks and streets shown;
  - v. owner dedicates to the City and the City's permittees the easements shown for utilities and cable television purposes;
  - vi. owner dedicates to the City the streets, alleys and other public places, including slope and construction easements and waives all claims for damages against any governmental authority including, without limitation, the City which may be occasioned to the adjacent land by the establishment, construction, drainage and maintenance of any public way so dedicated; and
  - vii. owner conveys to the City as general City property the buffer strips adjoining unplatted property.
- h. The drawing shall:
- i. be a legibly drawn, printed or reproduced permanent map;
  - ii. if more than one sheet is required, each sheet shall show sheet numbers for the total sheets;
  - iii. have margins that comply with the standards of the Spokane county auditor;
  - iv. show in dashed lines the existing plat being replatted, if applicable;
  - v. show monuments in accordance with [SMC 17G.080.020\(H\)\(1\)](#);
  - vi. include any other information required by the conditions of approval; and
  - vii. include any special statements of approval required from governmental agencies, including those pertaining to flood hazard areas, shorelines, critical areas and connections to adjacent state highways.

#### H. Filing.

Once the final plat has been reviewed, approved and signed by the applicable departments, the applicant shall file the final short plat with the county auditor within ten days of approval. No permits shall be issued for a proposed lot until the required conformed copies of the short plat have been submitted to the planning services department.

#### I. Redivision.

No land within the boundaries of a short subdivision may be further divided in any manner which will create additional lots within a period of five years except by subdivision in accordance with [SMC 17G.080.050](#)

Section 12: Section 17G.080.060 Binding Site Plan is amended to read as follows:

A. Purpose.

The purpose of this section is to allow for the more flexible creation of lots within an overall development site plan.

B. Predevelopment Meeting.

A predevelopment meeting is recommended (~~required~~) if the proposal is located in the central business district, unless waived by the director, and is recommended for all other proposals prior to submittal of the application. The purpose of a predevelopment meeting is to acquaint the applicant with the applicable provisions of this chapter, minimum submission requirements and other plans or regulations, which may impact the proposal.

C. Preliminary Binding Site Plan Application and Map Requirements.

1. A binding site plan may be used for divisions of land in all zones. Applications for approval of a preliminary binding site plan shall be filed with the director. All applications shall be submitted on forms provided for such purpose by the department. The director may waive specific submittal requirements determined to be unnecessary for review of the application. The application shall be same in form and contents as a short plat as provided in [SMC 17G.080.040\(B\)\(1\)](#).

2. Contents of Preliminary Binding Site Plan.

The preliminary binding site plan shall be prepared by a land surveyor and shall be the same in form and content as a short plat as provided in [SMC 17G.080.040\(B\)\(2\)](#) with the following additions:

- a. Proposed building footprints;
- b. Proposed street accesses;
- c. Proposed parking and internal vehicle circulation;
- d. Proposed pedestrian pathways;
- e. Proposed landscaped areas; and
- f. Proposed stormwater facilities.

D. Public Notice

All public notice of the application shall be given in accordance with the procedures set forth in [chapter 17C.061 SMC](#) for a Type II application.

E. Departmental Review of Preliminary Binding Site Plan

The application shall be reviewed in accordance with the procedures set forth in [chapter 17G.061 SMC](#) for a Type II application.

#### F. Preliminary Binding Site Plan Decision Criteria

Prior to approval of the application, the director shall find the application to be in the public use and interest, conform to applicable land use controls and the comprehensive plan of the City, and the decision criteria set forth in [SMC 17G.080.025](#). The director has the authority to approve or disapprove a proposed preliminary binding site plan under the provisions of this chapter, subject to appeal as provided in [chapter 17G.061 SMC](#).

#### G. Final Binding Site Plan Review Procedure

The final binding site plan procedures shall be the same in form as the short plat review procedure as provided in [SMC 17G.080.040\(G\)](#).

#### H. Final Binding Site Plan Requirements.

The subdivider shall submit to the director a final binding site plan in the same form and with the same content as the preliminary binding site plan, with the following exceptions or additional requirements:

1. A final binding site plan shall contain all the information required of the preliminary plan, except the following:
  - a. Show existing buildings.
  - b. Show existing utility lines and underground structures.
  - c. Show the topographical elevations; or
  - d. Contain the names and addresses of adjoining landowners.
2. The final binding site plan shall include the signatory statements as provided in [SMC 17G.080.040\(G\)\(2\)](#).

#### I. Filing

Once the final binding site plan has been reviewed, approved and signed by the applicable departments, the applicant shall file the final binding site plan with the county auditor within ten days of final approval. No permits shall be issued for a proposed lot until the required conformed copies of the binding site plan have been submitted to the department.

#### J. Creation of Additional Lots in Final Binding Site Plan

A survey may be filed following the recording of a final binding site plan to create additional lots within the boundaries of the final binding site plan, consistent with the preliminary binding site plan approval, conditions and expiration provisions ([SMC 17G.080.020\(C\)](#)). The survey shall be reviewed and approved by the director pursuant to subsections (F) and (G) of this section. In addition, the survey shall conform to the following:

1. Title shall state: "Amendment to BSP- \_\_\_ - \_\_\_\_."

2. The binding site plan file number shall be referenced.
3. A distinct wide boundary line shall delineate the boundary of the lot(s) being created. The boundary of the binding site plan shall be indicated and any lot(s) that have been created by filing of the final binding site plan and/or record of survey.
4. Each lot shall be numbered consecutively, and the size of each lot shall be indicated on the survey; and
5. A revision block listing all previously recorded surveys and the date of recording.

Section 12: Severability. If any section, subsection, sentence, clause, phrase or word of this ordinance should be held to be invalid or unconstitutional by a court of competent jurisdiction, such invalidity or unconstitutionality thereof shall not affect the validity or constitutionality of any other section, subsection, sentence, clause, phrase or word of this ordinance.

Section 13: Clerical Errors. Upon approval by the city attorney, the city clerk is authorized to make necessary corrections to this ordinance, including scrivener's errors or clerical mistakes; references to other local, state, or federal laws, rules, or regulations; or numbering or referencing of ordinances or their sections and subsections.

Section 14: Effective Date. This ordinance shall become effective upon passage and approval on January 1, 2025.

PASSED by the City Council on \_\_\_\_\_

\_\_\_\_\_  
Council President

Attest:

Approved as to form:

\_\_\_\_\_  
City Clerk

\_\_\_\_\_  
Assistant City Attorney

\_\_\_\_\_  
Mayor

\_\_\_\_\_  
Date

\_\_\_\_\_  
Effective Date

**CITY OF SPOKANE PLAN COMMISSION  
FINDINGS OF FACT, CONCLUSIONS, AND RECOMMENDATIONS  
REGARDING SB 5290 EXPEDITED PERMITTING CODE UPDATES**

A recommendation of the City of Spokane Plan Commission to the City Council to approve amendments to amendments to Title 17 of the Spokane Municipal Code to update land use application procedures which clarify, expedite, and consolidate the land use permitting process in accordance with Senate Bill 5290. Specifically amending Section 17A.020.030 “C” Definitions, Section 17A.020.200 “T” Definitions, Section 17E.020.080 Application Submittal Requirements, Section 17E.030.060 Establishment of Development Permit, Section 17E.040.080 Application Submittal Requirements, Section 17E.070.080 Application Submittal Requirements, Section 17G.061.110 Application Requirements, Section 17G.061.120 Determination of a Complete Application, Section 17G.061.130 Application Time Limits, Section 17G.061.150 Modification of Applications and Permits, Section 17G.080.040 Short Subdivisions, Section 17G.080.060 Binding Site Plan, and other matters properly related thereto.

**FINDINGS OF FACT:**

- A. The City of Spokane adopted a Comprehensive Plan in May of 2001 that complies with the requirements of the Growth Management Act (GMA) as set forth in RCW 36.70A.
- B. The proposed text amendments are mandated by State Legislature in order to be in compliance with Senate Bill 5290 which amends land use application procedures in order to expedite the land use permitting process.
- C. Consistency with Senate Bill 5290 is a requirement on the Periodic Update Checklist for Fully-Planning Cities and advances our work on the required Periodic Update to the Comprehensive Plan 2026 and the required development code amendments.
- D. The proposed text amendments do not significantly alter the outcome and purpose of the Unified Development Code and therefore remain consistent with the City of Spokane’s Comprehensive Plan.
- E. Public notice and communication began in August 2024 and included the following:
  1. A Plan Commission workshop on August 28, 2024.
  2. A Plan Commission Public Hearing on September 25, 2024.
- F. No public comment was received.
- G. On August 28, 2024, the City of Spokane Plan Commission held a workshop to discuss draft language, and review and evaluate with city staff alternatives to proposed text changes.
- H. On August 09, 2024, the Washington State Department of Commerce and appropriate state agencies were given the required 60-day notice before adoption of proposed changes to the Unified Development Code pursuant to RCW 36.70A.106.
- I. The proposed text amendments are categorically exempt from SEPA under WAC 197-11-8000 article 19 under procedural actions.

## Findings of Fact, Conclusion, and Recommendation

- J. A legal notice of public hearing was published in the *Spokesman-Review* on September 11, 2024 and September 18, 2024.
- K. The proposed text amendments were drafted and reviewed consistent with the requirements of RCW 36.70A.370 to assure protection of private property rights.
- L. Amendments to the Unified Development Code Title 17 are subject to the review and recommendation by the City of Spokane Plan Commission.
- M. The Plan Commission held a public hearing on September 25, 2024, to obtain public comments on the proposed amendments. No comments were received.
- N. The City of Spokane Plan commission adopts the findings and analysis set forth in the staff report prepared for the proposal.
- O. The City of Spokane Plan Commission finds that the proposed text amendments meet the decision criteria established in SMC 17G.025.010(G).

### **CONCLUSIONS:**

Based upon the draft text amendments, staff report and analysis (which is hereby incorporated into these findings, conclusions, and recommendations), SEPA review, agency and public comments received, and public testimony presented, the Spokane Plan Commission makes the following conclusions with respect to the proposed Paper Cuts Q1 2024 Code Amendments:

1. The Plan Commission finds that the proposed amendments bear a substantial relation to the public health, safety, welfare, and protection of the environment pursuant to the requirements outlined in SMC 17G.025.010(G).
2. The proposed text amendments will implement the goals and policies of the City of Spokane Comprehensive Plan.
3. Interested agencies and the public have had opportunities to participate throughout the process and persons desiring to comment were given an opportunity to comment.
4. The Plan Commission finds that the proposed amendments are consistent with the applicable provisions of the Comprehensive Plan.

### **RECOMMENDATION:**

In the matter of the ordinances pertaining to the proposed text amendments, amending the Unified Development Code of the City of Spokane.

As based on the above listed findings and conclusions, by unanimous vote of 8 in favor to 0 not in favor, the Spokane Plan Commission takes the following actions:

1. Recommends to the Spokane City Council the **APPROVAL** of the proposed amendments to Section 17A.020.030 "C" Definitions.
2. Recommends to the Spokane City Council the **APPROVAL** of the proposed amendments to Section 17A.020.200 "T" Definitions.
3. Recommends to the Spokane City Council the **APPROVAL** of the proposed amendments to [Section 17E.020.080](#) Application Submittal Requirements.

Findings of Fact, Conclusion, and Recommendation

4. Recommends to the Spokane City Council the **APPROVAL** of the proposed amendments to [Section 17E.030.060](#) Establishment of Development Permit.
5. Recommends to the Spokane City Council the **APPROVAL** of the proposed amendments to [Section 17E.040.080](#) Application Submittal Requirements.
6. Recommends to the Spokane City Council the **APPROVAL** of the proposed amendments to [Section 17E.070.080](#) Application Submittal Requirements.
7. Recommends to the Spokane City Council the **APPROVAL** of the proposed amendments to [Section 17G.061.110](#) Application Requirements.
8. Recommends to the Spokane City Council the **APPROVAL** of the proposed amendments to [Section 17G.061.120](#) Determination of a Complete Application.
9. Recommends to the Spokane City Council the **APPROVAL** of the proposed amendments to [Section 17G.061.130](#) Application Time Limits.
10. Recommends to the Spokane City Council the **APPROVAL** of the proposed amendments to [Section 17G.061.150](#) Modification of Applications and Permits.
11. Recommends to the Spokane City Council the **APPROVAL** of the proposed amendments to [Section 17G.080.040](#) Short Subdivisions.
12. Recommends to the Spokane City Council the **APPROVAL** of the proposed amendments to [Section 17G.080.060](#) Binding Site Plan.
  
13. Authorizes the President to prepare and sign on the Commission's behalf a written decision setting forth the Plan Commission's findings, conclusions, and recommendations on the proposed amendments.

*Greg Francis*

[Greg Francis \(Sep 26, 2024 17:38 PDT\)](#)

---

**Greg Francis, President**

**Spokane Plan Commission**

**Date: Sep 26, 2024**









# Findings and Conclusions SB5290 Land Use Application Code Updates

Final Audit Report

2024-09-27

Created:	2024-09-26
By:	Angela McCall (amccall@spokanecity.org)
Status:	Signed
Transaction ID:	CBJCHBCAABAAGWaHwhEGmfWG_2AqN9V3Vh6jpgF_EXpY

## "Findings and Conclusions SB5290 Land Use Application Code Updates" History

-  Document created by Angela McCall (amccall@spokanecity.org)  
2024-09-26 - 3:42:01 PM GMT
-  Document emailed to gfrancis@spokanecity.org for signature  
2024-09-26 - 3:42:22 PM GMT
-  Email viewed by gfrancis@spokanecity.org  
2024-09-27 - 0:38:19 AM GMT
-  Signer gfrancis@spokanecity.org entered name at signing as Greg Francis  
2024-09-27 - 0:38:51 AM GMT
-  Document e-signed by Greg Francis (gfrancis@spokanecity.org)  
Signature Date: 2024-09-27 - 0:38:53 AM GMT - Time Source: server
-  Agreement completed.  
2024-09-27 - 0:38:53 AM GMT



# STAFF REPORT

PLANNING AND ECONOMIC DEVELOPMENT SERVICES DEPARTMENT

<b>To:</b>	Plan Commission
<b>Subject:</b>	SB5290 Expedited Permitting Code Updates
<b>Staff Contact:</b>	Tim Thompson, Principal Planner, Jackie Churchill, Planner I
<b>Report Date:</b>	September 17, 2024
<b>Hearing Date:</b>	September 25 2024
<b>Recommendation:</b>	Approval

## I. SUMMARY

The proposed draft code amendments have been developed to update Land Use Application permitting requirements in accordance with Senate Bill 5290.

## II. RECOMMENDED ACTION

Planning staff recommend approval of these code text amendments, confirmation that they are compliant with the State Legislature’s Senate Bill 5290 mandated amendments to Chapter 17G.061 Land Use Application Procedures, and a motion to take them to City Council for adoption.

## III. BACKGROUND

In 2023, Washington State Legislature passed Senate Bill 5290 to update the Local Project Review Act in order to improve project review and permitting processes. These updates include clarification on the determination of completeness procedural requirements, new permitting deadlines, and mitigation measures to prevent the City from missing the deadline. These updates amend various sections of Chapter 17G Land Use Application Procedures of the Spokane Municipal Code. The effective date for these updates is January 1, 2025.

Senate Bill 5290 updated requirements for the determination of completeness process by stipulating that the determination must be based solely on procedural requirements. SB5290 also revised the existing 120-day time period for project review, creating multiple new time periods based on permit type. Additionally, Cities are now required to refund 10-20% of permit fees if the new time periods are not met; however, local governments do not need to refund permit fees if they adopt additional measures, provided in SB5290, to expedite permit review.

## IV. PROCESS

### DEVELOPMENT CODE AMENDMENT PROCEDURE

Article III Section 21, Amendments and Repeals, of the City of Spokane Charter provides for the ability of amendments of the Charter and Spokane Municipal Code through ordinances. Title 17 is known as the Unified Development Code (UDC) and is incorporated into the Spokane Municipal Code to implement the City's Comprehensive Plan, and by reference, the requirements of the Washington State Growth Management Act (GMA). Section 17G.025.010 establishes the procedure and decision criteria that the City uses to review and amend the UDC. The City may approve amendments to the UDC if it is found that a proposed amendment is consistent with the provisions of the Comprehensive Plan, and bears a substantial relation to public health, safety, welfare, and protection of the environment.

---

## ROLE OF THE CITY PLAN COMMISSION

The proposed text amendments require a review process set forth in Section 17G.025.010(F) SMC. The Plan Commission is responsible for holding a public hearing and forwarding its findings, conclusions, and recommendations to the City Council. Utilizing the decision criteria in 17G.025 SMC, the Plan Commission may recommend approval, modification, or denial of the proposal. The Plan Commission may incorporate the facts and findings of the staff report as the basis for its recommendation to the City Council or may modify the findings as necessary to support their final recommendation.

---

## ROLE OF CITY COUNCIL

As part of the Ordinance update process, the City Council will deliberate and review the proposed text amendments, public comments and testimony, the staff report, and any Plan Commission recommendation. The final decision to approve, modify, or deny the proposed amendments rests with the City Council. Proposals adopted by ordinance after public hearings are official amendments to the Spokane Municipal Code.

## COMMUNITY ENGAGEMENT

Plan Commission Workshop     August 28, 2024

## SEPA REVIEW

The proposed amendments are categorically exempt from SEPA review under WAC 197-11-800 section 19.

## COMMENTS RECEIVED

No comments have been received.

## V. ANALYSIS

### PROPOSAL DESCRIPTION

The proposed draft code amendments have been developed to update 17G Land Use Application Procedures permitting requirements in accordance with Senate Bill 5290 which mandates that the permitting process shall be expedited and clarified.

Proposed amendments to Section 17G.061.120 Determination of a Complete Application comply with section 6 of Senate Bill 5290 and updates to RCW36.70B.070, which require that the determination of completeness procedural requirements be based solely on the completion of the procedural requirements as listed in the project permit application. Draft changes also clarify the City deadlines and mandates that

communication to the applicant must be written. In addition, Sections 17A.020.030 “C” Definitions, Section 17A.020.200 “T” Definitions, are amended to add definitions for “Counter Complete” and “Technically Complete” in order to clarify how these terms relate to state terminology.

Proposed amendments to Section 17G.061.130 Application Time Limits and 17G.061.150 Modification of Applications and Permits comply with SB 5290 Section 7 and updates to 36.70B.080, which create new permitting time periods that are dependent upon the type of Land Use permit that is being applied for. Exceptions to the time periods have also been proposed in these sections.

The proposed amendments to Section 17G.061.110 Application Requirements, Section 17G.080.040 Short Subdivisions, Section 17G.080.060 Binding Site Plan, Section 17E.020.080 Application Submittal Requirements, Section 17E.030.060 Establishment of Development Permit, Section 17E.040.080 Application Submittal Requirements, Section 17E.070.080 Application Submittal Requirements, comply with section 8 of SB 5290 and updates to RCW 36.70B.160 which mandate that local governments adopt additional measures in lieu of refunding permitting fees if the permitting time periods are missed. These proposed amendments would change Pre-development meetings from “required” to “recommended”.

## IMPLEMENTATION OF COMPREHENSIVE PLAN GOALS AND POLICIES

Section 17G.025.010 SMC establishes the review criteria for text amendments to the Unified Development Code. In order to approve a text amendment, City Council shall consider the findings and recommendations of the Plan Commission along with the approval criteria outlined in the Code. The applicable criteria are shown below in *bold and italic* with staff analysis following criteria. Review of the Comprehensive Plan goals and policies indicates that the proposal meets the approval criteria for internal consistency set forth in SMC 17G.025.010(G). Excerpts of the applicable goals and policies, and their Comprehensive Pla discussion points, are contained in **Exhibit C**.

---

### ECONOMIC DEVELOPMENT GOALS

#### **ED 7 REGULATORY ENVIRONMENT AND TAX STRUCTURE**

Goal: Create a regulatory environment and tax structure that encourage investment, nurture economic activity, and promote a good business climate.

***POLICY: ED 7.6 - Development Standards and Permitting Process***

*Periodically evaluate and improve the City of Spokane’s development standards and permitting process to ensure that they are equitable, cost-effective, timely, and meet community needs and goals*

**Staff Analysis:**

The proposed amendments implement the Comprehensive Plan Economic Development Goal 7 to nurture economic activity through the regulatory environment by complying with State law which mandates transparent and timely permitting processes. They also specifically implement policy 7.6 by creating new permitting time periods to ensure timeliness, clarify the determination of completeness process, and creating additional measures that help to expedite the Land Use Application permitting process.

## FINAL REVIEW CRITERIA

### 2. Consistency with State law: Senate Bill 5290

**Staff Analysis:** The draft amendments have been proposed in order to make updates to the Chapter 17G.061 Land Use Application Procedures code in compliance with the 2023 Senate Bill 5290. SB 5290 updated the Local Project Review Act RCW 36.70B and amended various sections including RCWs 36.70B.070, 36.70B.080, and 36.70B.160. Corresponding sections of the Unified Development Code have been updated to comply with changes to the amended RCWs.

### 3. Consistency with the Comprehensive Plan Periodic Update Requirements

**Staff Analysis:** Consistency with Senate Bill 5290 is a requirement on the Periodic Update Checklist for Fully-Planning Cities and advances our work on the required Periodic Update to the Comprehensive Plan 2026 and the required development code amendments.

### 4. *Public Health, Safety, Welfare, and Protection of the Environment.*

**Staff Analysis:** By updating requirements for the Land Use Application Procedures, the proposed amendments comply with State Law which does not adversely affect public health, safety or the welfare of the public.

## VI. CONCLUSION

Based on the facts and findings presented herein, staff concludes that the requested text amendments to the Unified Development Code 17G.061 Land Use Application Procedures satisfy the applicable criteria for approval as set forth in SMC Section 17G.025.010.

## VII. STAFF RECOMMENDATION

Following the close of public testimony and deliberation regarding conclusions with respect to the review criteria and decision criteria detailed in SMC 17G.025.010, Plan Commission will need to make a recommendation to City Council for approval, approval with modification, or denial of the requested code amendments to the Unified Development Code.

Staff **recommends approval** of the requested amendments and recommends that the Plan Commission adopt the facts and findings of the staff report.

## VIII. LIST OF EXHIBITS

- A. Summary Table of Proposed Text Amendments
- B. Proposed Draft Text
- C. Related Comprehensive Goals and Policies
- D. Findings and Conclusions

EXHIBIT A – SUMMARY TABLE OF PROPOSED TEXT AMENDMENTS

**SB 5290 Expedited Permitting Process Updates  
Proposed Text Amendment Tracker**

*The text amendment tracking sheet provides a summary of proposed changes in each section of the Spokane Municipal Code. The text amendment tracking sheet does not replace reviewing the draft code text amendments as there may be additional details and/or minor changes that were not captured in this document.*

Existing SMC Section	Corresponding sections of SB5290 and RCWs	Description of Change
<b><u>Section 17G.061.110</u> Application Requirements</b>		
Subsection 3	Section 8(2) RCW 36.70B.160	<ul style="list-style-type: none"> <li>○ Removed subsection 3 because the reference to the Central Business District is outdated.</li> <li>○ Removing 3 allows the Pre-Development Conference to be a recommendation instead of mandatory. *This is a suggested measure in SB5290 section 8 to expedite permits and 2 of 3 needed measures that can replace the mandate to partially refund fees for missing permitting deadlines.</li> </ul>
<b><u>Section 17G.080.040</u> Short Subdivisions</b>		
A. Predevelopment Meeting	Section 8(2) RCW 36.70B.160	<ul style="list-style-type: none"> <li>○ Removed reference to the Central Business District as reference is outdated.</li> <li>○ *This is a suggested measure in SB5290 section 8 to expedite permits and 2 of 3 needed measures that can replace the mandate to partially refund fees for missing permitting deadlines.</li> </ul>
<b><u>Section 17G.080.060</u> Binding Site Plan</b>		
B. Predevelopment Meeting	Section 8(2) RCW 36.70B.160	<ul style="list-style-type: none"> <li>○ Removed reference to the Central Business District as reference is outdated.</li> <li>○ *This is a suggested measure in SB5290 section 8 to expedite permits and 2 of 3 needed measures that can replace the mandate to partially refund fees for missing permitting deadlines.</li> </ul>

<a href="#">Section 17E.020.080</a> <b>Application Submittal Requirements – Fish &amp; Wildlife Conservation Areas</b>		
A	Section 8(2) RCW 36.70B.160	<ul style="list-style-type: none"> <li>○ Changed “required” to “recommended”</li> <li>○ *This is a suggested measure in SB5290 section 8 to expedite permits and 2 of 3 needed measures that can replace the mandate to partially refund fees for missing permitting deadlines.</li> </ul>
<a href="#">Section 17E.030.060</a> <b>Establishment of Development Permit</b>		
B	Section 8(2) RCW 36.70B.160	<ul style="list-style-type: none"> <li>○ Changed “required” to “recommended”</li> <li>○ *This is a suggested measure in SB5290 section 8 to expedite permits and 2 of 3 needed measures that can replace the mandate to partially refund fees for missing permitting deadlines.</li> </ul>
<a href="#">Section 17E.040.080</a> <b>Application Submittal Requirements – Geologically Hazardous Areas</b>		
A	Section 8(2) RCW 36.70B.160	<ul style="list-style-type: none"> <li>○ Changed “required” to “recommended”</li> <li>○ *This is a suggested measure in SB5290 section 8 to expedite permits and 2 of 3 needed measures that can replace the mandate to partially refund fees for missing permitting deadlines.</li> </ul>
<a href="#">Section 17E.070.080</a> <b>Application Submittal Requirements - Wetlands</b>		
<a href="#">Chapter 17E.070 Wetlands Protection</a> <a href="#">Section 17E.070.080</a> Application Submittal Requirements (A)	Section 8(2) RCW 36.70B.160	<ul style="list-style-type: none"> <li>○ Changed “required” to “recommended”</li> <li>○ *This is a suggested measure in SB5290 section 8 to expedite permits and 2 of 3 needed measures that can replace the mandate to partially refund fees for missing permitting deadlines.</li> </ul>



<b>Section 17G.061.120 Determination of a Complete Application</b>		
(A)	Section 6 RCW 36.70B.070	<ul style="list-style-type: none"> <li>○ Changed all instances of “procedural” to “technical” to match current City terminology.</li> <li>○ Added subsections 1 &amp; 2 <ul style="list-style-type: none"> <li>○ Subsection 1 states how days are counted.</li> <li>○ Subsection 2 states that on the 29<sup>th</sup> day after an application is submitted it is deemed technically complete if the City hasn’t issued a written statement to the contrary.</li> </ul> </li> </ul>
B. Procedures for Determination of Completeness  (2) Component Screening	Section 6 RCW 36.70B.070	<ul style="list-style-type: none"> <li>○ Amended to add that applicants will receive a written determination of counter complete or incomplete.</li> <li>○ New subsection (a) added to state that after 2 requests for corrections or more info., staff may schedule a meeting to resolve the issues and it must be within 14 days of the request.</li> <li>○ New subsection b added to state that after 3 requests for corrections, the application must be approved or denied. *This is a measure suggested by SB5290 section 8 that the City adopt to expedite permitting. This is 3 of 3 necessary measures to avoid having to refund fees in the case of missing permitting timelines.</li> </ul>
(3) Review by Interested Parties	Section 6 RCW 36.70B.070	<ul style="list-style-type: none"> <li>○ Reordered and combined subsections 3 and 4.</li> <li>○ 4 was changed to a subsection of 3 and renamed "Application Certification" and reworded to clarify that applicants will be notified in writing if the application is complete or not.</li> <li>○ a-d were moved to be subsections under (a) Application Certification (previously 4) to clarify the chronological steps of the application process and they are renumbered to i-iv.</li> <li>○ Subsection iv: removed “pursuant to paragraph D herein below” for clarity.</li> </ul>
(4) Application Certified Complete	Section 6 RCW 36.70B.070	<ul style="list-style-type: none"> <li>○ New section 4 to clarify when an application is considered technically complete.</li> </ul>
(6) Vesting	Section 6 RCW 36.70B.070	<ul style="list-style-type: none"> <li>○ Changed “certified” to “counter” complete and added that fees must be paid before the application can be vested.</li> <li>○ Added subsection (a) to state that vested applications may expire according to each permit type expiration dates found in Table 17G.061.010-1.</li> <li>○</li> </ul>

<b>Section 17G.061.130 Application Time Limits</b>		
Section A	Section 7(1)(a)-(k) RCW 36.70B.080	<ul style="list-style-type: none"> <li>○ Edited to include the state mandated permitting timelines.</li> </ul>
Section B	Section 7(1)(a)-(k) RCW 36.70B.080	<ul style="list-style-type: none"> <li>○ Additional verbiage added to clarify exceptions to the permitting timeline.</li> <li>○ B (1) amended to clarify that the timeline pause ends once the applicant has sent additional information to the City.</li> <li>○ B (4) amended to add the clause that the city may add an additional 30 days to the time period if the applicant asks for a 60 day extension or if the applicant is not responsive for more than 60 days.</li> <li>○ B (6) new subsection added to state that the time period restarts if substantial changes are made to the permit as outlined in 17G.061.150.</li> <li>○ B (7) added to clarify that Comprehensive Plan Amendments are not subject to the timeline requirements.</li> </ul>
Section C	Section 7(1)(a)-(k) RCW 36.70B.080	<ul style="list-style-type: none"> <li>○ New section to state that the City may adopt alternative timelines for different permitting scenarios and types.</li> </ul>
<b>Section 17G.061.150 Modification of Applications and Permits</b>		
Section A(1)(a)		<ul style="list-style-type: none"> <li>○ Amended by adding the word “minor” for clarity.</li> </ul>
<b>Section 17A.020.030 “C” Definitions</b>		
“C” Definitions		<ul style="list-style-type: none"> <li>○ Added a definition of “Counter Complete” to clarify that counter complete and technically complete are different.</li> </ul>
<b>Section 17A.020.200 “T” Definitions</b>		
“T” Definitions		<ul style="list-style-type: none"> <li>○ Added a definition of “Technically Complete”.</li> </ul>



## 1. Title 17A Administration

### Chapter 17A.020 Definitions

#### Section 17A.020.030 "C" Definitions

##### A. Candidate Species.

A species of fish or wildlife, which is being reviewed, for possible classification as threatened or endangered.

##### B. Carport.

A carport is a garage not entirely enclosed on all sides by sight-obscuring walls and/or doors.

##### C. Cellular Telecommunications Facility.

They consist of the equipment and structures involved in receiving telecommunication or radio signals from mobile radio communications sources and transmitting those signals to a central switching computer that connects the mobile unit with the land-based telephone lines.

##### D. Central Business District.

The general phrase "central business district" refers to the area designated on the comprehensive plan as the "downtown" and includes all of the area encompassed by all of the downtown zoning categories combined.

##### E. Certificate of Appropriateness.

Written authorization issued by the commission or its designee permitting an alteration or significant change to the controlled features of a landmark or landmark site after its nomination has been approved by the commission.

##### F. Certificate of Capacity.

A document issued by the planning and economic development services department indicating the quantity of capacity for each concurrency facility that has been reserved for a specific development project on a specific property. The document may have conditions and an expiration date associated with it.

##### G. Certified Erosion and Sediment Control Lead (CESCL).

An individual who is knowledgeable in the principles and practices of erosion and sediment control. The CESCL shall have the skills to assess the:

1. site conditions and construction activities that could impact the quality of stormwater, and
2. effectiveness of erosion and sediment control measures used to control the quality of stormwater discharges.

The CESCL shall have current certification through an approved erosion and sediment control training program that meets the minimum training standards established by the Washington State department of ecology.

#### H. Change of Use.

For purposes of modification of a preliminary plat, "change of use" shall mean a change in the proposed use of lots (e.g., residential to commercial).

#### I. Channel Migration Zone (CMZ).

A corridor of variable width that includes the current river plus adjacent area through which the channel has migrated or is likely to migrate within a given timeframe, usually one hundred years.

#### J. Channelization.

The straightening, relocation, deepening, or lining of stream channels, including construction of continuous revetments or levees for the purpose of preventing gradual, natural meander progression.

#### K. City.

The City of Spokane, Washington.

#### L. City Engineer.

The Director of the Engineering Services department, or their designee for approval authority.

#### M. Clear Street Width.

The width of a street from curb to curb minus the width of on-street parking lanes.

#### N. Clear Pedestrian Zone.

Area reserved for pedestrian traffic; typically included herein as a portion of overall sidewalk width to be kept clear of obstructions to foot traffic.

O. Clear View Triangle.

1. A clear view maintained within a triangular space at the corner of a lot so that it does not obstruct the view of travelers upon the streets.

KEEP CURRENT IMAGE

2. Intersection of local and arterial: A right triangle having a fifteen-foot side measured along the curb line of the residential street and a seventy-five foot side along the curb line of the intersecting arterial street, except that when the arterial street has a speed limit of thirty-five miles per hour, the triangle has a side along such arterial of one hundred twenty-two feet, or when the arterial speed limit is 40 mph or greater the dimensions of the triangle shall be determined by Street Department staff using AASHTO's A Policy on Geometric Design as a reference.

KEEP CURRENT IMAGE

3. Alleys: A right isosceles triangle having sides of seven feet measured along the right-of-way line of an alley and:
  - a. the inside line of the sidewalk; or
  - b. if there is no sidewalk, a line seven feet inside the curb line.

KEEP CURRENT IMAGE

P. Clear Zone.

The roadside area free of obstacles, starting at the edge of the traveled way.

Q. Clearing.

The removal of vegetation or plant cover by manual, chemical, or mechanical means. Clearing includes, but is not limited to, actions such as cutting, felling, thinning, flooding, killing, poisoning, girdling, uprooting, or burning.

R. Cliffs.

A type of habitat in the Washington department of fish and wildlife (WDFW) priority habitat and species system that is considered a priority due to its limited availability, unique species usage, and significance as breeding habitat. Cliffs are greater than twenty-five feet high and below five thousand feet elevation.

A "cliff" is a steep slope of earth materials, or near vertical rock exposure. Cliffs are categorized as erosion landforms due to the processes of erosion and weathering that produce them. Structural cliffs may form as the result of fault displacement or the resistance

of a cap rock to uniform downcutting. Erosional cliffs form along shorelines or valley walls where the most extensive erosion takes place at the base of the slope.

S. Closed Record Appeal Hearing.

A hearing, conducted by a single hearing body or officer authorized to conduct such hearings, that relies on the existing record created during a quasi-judicial hearing on the application. No new testimony or submission of new evidence and information is allowed.

T. Collector Arterial.

Collector arterials (consisting of Major and Minor Collectors) collect and distribute traffic from local streets to principal and minor arterials. They serve both land access and traffic circulation.

U. Co-location.

Is the locating of wireless communications equipment from more than one provider on one structure at one site.

V. Colony.

A hive and its equipment and appurtenances, including one queen, bees, comb, honey, pollen, and brood.

W. Commercial Driveway.

Any driveway access to a public street other than one serving a single-family or duplex residence on a single lot.

X. Commercial Vehicle.

Any vehicle the principal use of which is the transportation of commodities, merchandise, produce, freight, animals, or passengers for hire.

Y. Commission – Historic Landmarks.

The City/County historic landmarks commission.

Z. Community Banner.

See SMC 17C.240.015.

#### AA. Community Meeting.

An informal meeting, workshop, or other public meeting to obtain comments from the public or other agencies on a proposed project permit prior to the submission of an application.

A community meeting is between an applicant and owners, residents of property in the immediate vicinity of the site of a proposed project, the public, and any registered neighborhood organization or community council responsible for the geographic area containing the site of the proposal, conducted prior to the submission of an application to the City of Spokane.

A community meeting does not constitute an open record hearing.

The proceedings at a community meeting may be recorded and a report or recommendation shall be included in the permit application file.

#### AB. Compensatory Mitigation.

Replacing project-induced wetland losses or impacts, and includes, but is not limited to, the following:

##### 1. Restoration.

The manipulation of the physical, chemical, or biological characteristics of a site with the goal of returning natural or historic functions to a former or degraded wetland. For the purpose of tracking net gains in wetland acres, restoration is divided into re-establishment and rehabilitation.

##### 2. Re-establishment.

The manipulation of the physical, chemical, or biological characteristics of a site with the goal of returning natural or historic functions to a former wetland. Re-establishment results in a gain in wetland acres (and functions). Activities could include removing fill material, plugging ditches, or breaking drain tiles.

##### 3. Rehabilitation.

The manipulation of the physical, chemical, or biological characteristics of a site with the goal of repairing natural or historic functions of a degraded wetland. Rehabilitation results in a gain in wetland function but does not result in a gain in wetland acres. Activities could involve breaching a dike to reconnect wetlands to a floodplain or return tidal influence to a wetland.

##### 4. Creation (Establishment).

The manipulations of the physical, chemical, or biological characteristics present to develop a wetland on an upland or deepwater site where a wetland did not previously exist.



Establishment results in a gain in wetland acres. Activities typically involve excavation of upland soils to elevations that will produce a wetland hydroperiod, create hydric soils, and support the growth of hydrophytic plant species.

5. Enhancement.

The manipulation of the physical, chemical, or biological characteristics of a wetland site to heighten, intensify, or improve specific function(s) or to change the growth stage or composition of the vegetation present. Enhancement is undertaken for specified purposes such as water quality improvement, flood water retention, or wildlife habitat. Enhancement results in a change in some wetland functions and can lead to a decline in other wetland functions, but does not result in a gain in wetland acres. Activities typically consist of planting vegetation, controlling non-native or invasive species, modifying site elevations or the proportion of open water to influence hydroperiods, or some combination of these activities.

6. Protection/Maintenance (Preservation).

Removing a threat to, or preventing the decline of, wetland conditions by an action in or near a wetland. This includes the purchase of land or easements, repairing water control structures or fences or structural protection such as repairing a barrier island. This term also includes activities commonly associated with the term preservation. Preservation does not result in a gain of wetland acres, may result in a gain in functions, and will be used only in exceptional circumstances.

AC. Counter Complete

A land use application is counter complete if the application contains the documents and information required by SMC 17G.061.110 and required fees have been paid. This is the first step in the Land Use Application Determination of Completeness as outlined in 17G.061.120 and the department may request additional information, documents, or studies before certifying the application as technically complete.

~~((AG))~~ AD. Comprehensive Plan.

The City of Spokane comprehensive plan, a document adopted pursuant to chapter 36.70A RCW providing land use designations, goals and policies regarding land use, housing, capital facilities, housing, transportation, and utilities.

~~((AD))~~ AE. Conceptual Landscape Plan.

A scale drawing showing the same information as a general site plan plus the location, type, size, and width of landscape areas as required by the provisions of chapter 17C.200 SMC.

The type of landscaping, L1, L2, or L3, is required to be labeled.

It is not a requirement to designate the scientific name of plant materials on the conceptual landscape plan.

((AE)) AF. Concurrency Certificate.

A certificate or letter from a department or agency that is responsible for a determination of the adequacy of facilities to serve a proposed development, pursuant to chapter 17D.010 SMC, Concurrency Certification.

((AF)) AG. Concurrency Facilities.

Facilities for which concurrency is required in accordance with the provisions of this chapter. They are:

1. transportation,
2. public water,
3. fire protection,
4. police protection,
5. parks and recreation,
6. libraries,
7. solid waste disposal and recycling,
8. schools, and
9. public wastewater (sewer and stormwater).

((AG)) AH. Concurrency Test.

The comparison of an applicant's impact on concurrency facilities to the available capacity for public water, public wastewater (sewer and stormwater), solid waste disposal and recycling, and planned capacity for transportation, fire protection, police protection, schools, parks and recreation, and libraries as required in SMC 17D.010.020.

((AH)) AI. Conditional Use Permit.

A "conditional use permit" and a "special permit" are the same type of permit application for purposes of administration of this title.

((AI)) AJ. Condominium.

Real property, portions of which are designated for separate ownership and the remainder of which is designated for common ownership solely by the owners of those portions. Real property is not a condominium unless the undivided interests in the common elements are vested in unit owners, and unless a declaration and a survey map and plans have been recorded pursuant to chapter 64.34 RCW.

~~((AJ))~~ AK. Confidential Shelter.

Shelters for victims of domestic violence, as defined and regulated in chapter 70.123 RCW and WAC 248-554. Such facilities are characterized by a need for confidentiality.

~~((AK))~~ AL. Congregate Residence.

A dwelling unit in which rooms or lodging, with or without meals, are provided for nine or more non-transient persons not constituting a single household, excluding single-family residences for which special or reasonable accommodation has been granted.

~~((AL))~~ AM. Conservancy Environments.

Those areas designated as the most environmentally sensitive and requiring the most protection in the current shoreline master program or as hereafter amended.

~~((AM))~~ AN. Container.

Any vessel of sixty gallons or less in capacity used for transporting or storing critical materials.

~~((AN))~~ AO. Context Areas

Established by the Regulating Plan, Context Area designations describe and direct differing functions and features for areas within FBC limits, implementing community goals for the built environment.

~~((AO))~~ AP. Contributing Resource

Contributing resource is any building, object, structure, or site which adds to the historical integrity, architectural quality, or historical significance of the local or federal historic district within which the contributing resource is located.

~~((AP))~~ AQ. Conveyance.

In the context of chapter 17D.090 SMC or chapter 17D.060 SMC, this term means a mechanism for transporting water from one point to another, including pipes, ditches, and channels.

~~((AQ))~~ AR. Conveyance System.

In the context of chapter 17D.090 SMC or chapter 17D.060 SMC, this term means the drainage facilities and features, both natural and constructed, which collect, contain and provide for the flow of surface and stormwater from the highest points on the land down to receiving water. The natural elements of the conveyance system include swales and small drainage courses, streams, rivers, lakes, and wetlands. The constructed elements of the conveyance system include gutters, ditches, pipes, channels, and most flow control and water quality treatment facilities.

~~((AR))~~ AS. Copy.

See SMC 17C.240.015.

~~((AS))~~ AT. Cottage Housing.

A grouping of residential units with a common open space.

~~((AT))~~ AU. Council.

The city council of the City of Spokane.

~~((AU))~~ AV. County.

Usually capitalized, means the entity of local government or, usually not capitalized, means the geographic area of the county, not including the territory of incorporated cities and towns.

~~((AV))~~ AW. Courtyard apartments.

Three or more attached dwelling units arranged on two or three sides of a yard or court.

~~((AW))~~ AX. Covenants, Conditions, and Restrictions (CC&Rs).

A document setting forth the covenants, conditions, and restrictions applicable to a development, recorded with the Spokane County auditor and, typically, enforced by a property owner's association or other legal entity.

~~((AX))~~ AY. Creep.

Slow, downslope movement of the layer of loose rock and soil resting on bedrock due to gravity.

((AY)) AZ. Critical Amount.

The quantity component of the definition of critical material.

((AZ)) BA. Critical Aquifer Recharge Areas (CARA).

Critical aquifer recharge areas (CARA) include locally identified aquifer sensitive areas (ASA) and wellhead protection areas.

((BA)) BB. Critical Areas.

Any areas of frequent flooding, geologic hazard, fish and wildlife habitat, aquifer sensitive areas, or wetlands as defined under chapter 17E.010 SMC, chapter 17E.020 SMC, chapter 17E.030 SMC, chapter 17E.040 SMC, and chapter 17E.070.SMC.

((BB)) BC. Critical Facility.

A facility for which even a slight chance of flooding might be too great. Critical facilities include, but are not limited to:

1. schools;
2. nursing homes;
3. hospitals;
4. police;
5. fire;
6. emergency response installations; and
7. installations which produce, use, or store hazardous materials or hazardous waste.

((BG)) BD. Critical Material.

1. A compound or substance, or class thereof, designated by the division director of public works and utilities which, by intentional or accidental release into the aquifer or ASA, could result in the impairment of one or more of the beneficial uses of aquifer water and/or impair aquifer water quality indicator levels. Beneficial uses include, but are not limited to:

- a. domestic and industrial water supply,
- b. agricultural irrigation,
- c. stock water, and

d. fish propagation.

Used herein, the designation is distinguished from state or other designation.

2. A list of critical materials is contained in the Critical Materials Handbook, including any City modifications thereto.

~~((B))~~ BE. Critical Material Activity.

A land use or other activity designated by the manager of engineering services as involving or likely to involve critical materials. A list of critical materials activities is contained in the Critical Materials Handbook.

~~((B))~~ BF. Critical Materials Handbook.

The latest edition of a publication as approved and amended by the division director of public works and utilities from time to time to accomplish the purposes of this chapter.

1. The handbook is based on the original prepared by the Spokane water quality management program ("208") coordination office, with the assistance of its technical advisory committee. It is on file with the director of engineering services and available for public inspection and purchase.

2. The handbook, as approved and modified by the division director of public works and utilities, contains:

- a. a critical materials list,
- b. a critical materials activities list, and
- c. other technical specifications and information.

3. The handbook is incorporated herein by reference. Its provisions are deemed regulations authorized hereunder and a mandatory part of this chapter.

~~((B))~~ BG. Critical Review.

The process of evaluating a land use permit request or other activity to determine whether critical materials or critical materials activities are involved and, if so, to determine what appropriate measures should be required for protection of the aquifer and/or implementation of the Spokane aquifer water quality management plan.

~~((B))~~ BH. Critical Review Action.

1. An action by a municipal official or body upon an application as follows:

- a. Application for a building permit where plans and specifications are required, except for Group R and M occupancies (SMC 17G.010.140 and SMC 17G.010.150).
- b. Application for a shoreline substantial development permit (SMC 17G.061.070(B)(1)).
- c. Application for a certificate of occupancy (SMC 17G.010.170).

- d. Application for a variance or a certificate of compliance SMC 17G.061.110.
- e. Application for rezoning SMC 17G.061.110.
- f. Application for conditional permit SMC 17G.061.110.
- g. Application for a business license (SMC 8.01.120).
- h. Application for a permit under the Fire Code (SMC 17F.080.060).
- i. Application for a permit or approval requiring environmental review in an environmentally sensitive area (SMC 17E.050.260).
- j. Application for connection to the City sewer or water system.
- k. Application for construction or continuing use of an onsite sewage disposal system (SMC 13.03.0149 and SMC 13.03.0304).
- l. Application for sewer service with non-conforming or non-standard sewage (SMC 13.03.0145, SMC 13.03.0314, and SMC 13.03.0324).
- m. Application involving a project identified in SMC 17E.010.120.
- n. Issuance or renewal of franchise; franchisee use of cathodic protection also requires approval or a franchise affecting the City water supply or water system.
- o. Application for an underground storage tank permit (SMC 17E.010.210); and
- p. Application for permit to install or retrofit aboveground storage tank(s) (SMC 17E.010.060(A) and SMC 17E.010.400(D)).

2. Where a particular municipal action is requested involving a land use installation or other activity, and where said action is not specified as a critical review action, the City official or body responsible for approval may, considering the objectives of this chapter, designate such as a critical review action and condition its approval upon compliance with the result thereof.

~~((B))~~ BI. Critical Review Applicant.

A person or entity seeking a critical review action.

~~((B))~~ BJ. Critical Review Officer – Authority.

1. The building official or other official designated by the director of public works and utilities.
2. For matters relating to the fire code, the critical review officer is the fire official.
3. The critical review officer carries out and enforces the provisions of this chapter and may issue administrative and interpretive rulings.
4. The critical review officer imposes requirements based upon this chapter, regulations, and the critical materials handbook.
5. The officer may adopt or add to any requirement or grant specific exemptions, where deemed reasonably necessary, considering the purpose of this chapter.

~~((BJ))~~ BK. Critical Review Statement.

A checklist, disclosure form, or part of an application for a critical review action, disclosing the result of critical review. Where not otherwise provided as part of the application process, the critical review officer may provide forms and a time and place to file the statement.

~~((BK))~~ BL. Cumulative Impacts.

The combined, incremental effects of human activity on ecological or critical area functions and values. Cumulative impacts result when the effects of an action are added to or interact with other effects in a particular place and within a particular time. It is the combination of these effects, and any resulting environmental degradation, that should be the focus of cumulative impact analysis and changes to policies and permitting decisions.

~~((BL))~~ BM. Curb Ramp.

A ramp constructed in the sidewalk to provide an accessible route from the sidewalk to the street.

~~((BM))~~ BN. Cutbank.

The concave bank of a moving body of water that is maintained as a steep or even overhanging cliff by the actions of water at its base.

Date Passed: Monday, November 20, 2023

Effective Date: Monday, January 1, 2024

ORD C36459 Section 3



## Title 17A Administration

### Chapter 17A.020 Definitions

#### Section 17A.020.200 "T" Definitions

##### A. Technically Complete

A term to describe a land use application that is certified as complete. A land use application will be deemed technically complete once all steps in 17G.061.120 Land Use Application Procedures for Determination of Completeness have been satisfied and all requested information has been correctly submitted to the City. This definition applies to applications determined procedurally complete as defined by RCW 36.70B.070.

##### ~~((A))~~ B. Temporary Erosion and Sediment Control Measures.

Erosion and sediment control devices used to provide temporary stabilization of a site, usually during construction or ground disturbing activities, before permanent devices are installed.

##### ~~((B))~~ C. Temporary Sign.

A sign placed on a structure or the ground for a specifically limited period of time as provided in SMC 17C.240.240(G).

##### ~~((C))~~ D. Temporary Structure.

A structure approved for location on a lot by the department for a period not to exceed six months with the intent to remove such structure after the time period expires.

##### ~~((D))~~ E. Tenant Space.

Portion of a structure occupied by a single commercial lease holder with its own public entrance from the exterior of the building or through a shared lobby, atrium, mall, or hallway and separated from other tenant spaces by walls.

##### ~~((E))~~ F. Through Pedestrian Zone.

The portion of a sidewalk that is intended for pedestrian travel and is entirely free of permanent and temporary objects.

##### ~~((F))~~ G. Tideland.

Land on the shore of marine water bodies between the line of ordinary high tide and the line of extreme low tide.

((G)) H. Total Maximum Daily Load (TMDL).

A calculation of the maximum amount of a pollutant that a water body can receive and still meet water quality standards, and an allocation of that amount to the pollutant's sources. A TMDL is the sum of the allowable loads of a single pollutant from all contributing point and non point sources. The calculation shall include a margin of safety to ensure that the water body can be used for the purposes the state has designated. The calculation shall also account for seasonable variation in water quality. Water quality standards are set by states, territories, and tribes. They identify the uses for each water body, for example, drinking water supply, contact recreation (swimming), and aquatic life support (fishing), and the scientific criteria to support that use. The Clean Water Act, section 303, establishes the water quality standards and TMDL programs.

((H)) I. [Deleted].

((I)) J. [Deleted].

((J)) K. [Deleted].

((K)) L. Tracking.

The deposition of sediment onto paved surfaces from the wheels of vehicles.

((L)) M. Tract.

A piece of land created and designated as part of a land division that is not a lot, lot of record or a public right-of-way. Tracts are created and designated for a specific purpose. Land uses within a tract are restricted to those uses consistent with the stated purpose as described on the plat, in maintenance agreements, or through conditions, covenants and restrictions (CC&Rs).

((M)) N. Traveled Way.

The area of street which is intended to carry vehicular traffic, excluding any shoulders.

((N)) O. Triplex.

A building that contains three dwelling units on the same lot that share a common wall or common floor/ceiling.

((O)) P. Type I Application.

An application for a project permit that is subject to an administrative approval and is not categorically exempt from environmental review under chapter 43.21C RCW (SEPA) and the City of Spokane Environmental Ordinance chapter 17E.050 SMC, and does not require a public hearing. Type I applications are identified in Table 17G.061.010-1 in chapter 17G.061 SMC. These applications may include, but are not limited to, building permits and grading permits.

((P)) Q. Type II Application.

An application for a project permit that is subject to an administrative decision of a department director, that may or may not be categorically exempt from chapter 43.21C RCW (SEPA), and does not require a public hearing. The Type II applications are identified in Table 17G.061.010-1 in chapter 17G.061 SMC. These applications may include, but are not limited to, short plats, binding site plans, shoreline substantial development permits, and some conditional use permits; provided, the planning director may require conditional use permits which are otherwise characterized as Type II applications under this title to be submitted and processed as Type III applications when the director issues written findings that the Type III process is in the public interest.

((Q)) R. Type III Application.

An application for a project permit that is subject to a quasi-judicial decision of the hearing examiner that may or may not be categorically exempt from chapter 43.21C RCW (SEPA) and the City of Spokane Environmental Ordinance chapter 17E.050 SMC and requires a public hearing. Type III applications are identified in Table 17G.061.010-1 in chapter 17G.061 SMC. These applications may include, but are not limited to, rezones, conditional use permits, preliminary long plats, or shoreline conditional use permits.

Date Passed: Monday, November 20, 2023

Effective Date: Monday, January 1, 2024

ORD C36459 Section 10

## Title 17E Environmental Standards

### Chapter 17E.020 Fish and Wildlife Conservation Areas

#### Section 17E.020.080 Application Submittal Requirements

- A. A pre-development conference is recommended (~~required~~) for all regulated activities proposed in potential fish and wildlife habitat conservation areas and associated buffers per chapter 17G.061 SMC. The pre-development conference is intended to acquaint an applicant with standards, requirements, investigation procedures, best management practice and potential review procedures prior to making application.
- B. A critical areas checklist is required at the time of application for all regulated activities proposed in fish and wildlife habitat areas and associated buffers per SMC 17G.061.110(C).
- C. All activities identified in SMC 17E.020.050 shall meet the following application submittal requirements in addition to the application submittal requirements specified in other codes. The director may modify the submittal requirements based upon reasonable documentation, including BAS, needed to ensure compliance with this chapter, provided no construction activity, clearing or grading has taken place. A written summary of analysis and findings shall be included in any staff report or decision on the underlying permit.

#### 1. Topographic Survey.

A topographic site plan, prepared and stamped by a State of Washington licensed surveyor, is required for sites that include a wetland or its buffer. The

- a. Existing topography at two-foot contour intervals on-site, on adjacent lands within twenty-five feet of the site's property lines, and on the full width of abutting public and private rights-of-way and easements.
- b. Terrain and stormwater-flow characteristics within the site, on adjacent sites within twenty-five feet of the site's property lines, and on the full width of abutting public and private rights-of-way and easements.
- c. Location of areas with significant amounts of vegetation, and specific location and description of all trees with trunks six inches or greater

in diameter measured four feet, six inches above the ground, and noting their species.

- d. Location and boundaries of all existing site improvements on the site, on adjacent lands within twenty-five feet of the site's property lines, and on the full width of abutting public and private rights-of-way and easements. This shall include the amounts of developmental coverage, including all impervious surfaces (noting total square footage and percentage of site occupied).
- e. Location of all grading activities in progress, and all natural and artificial drainage control facilities or systems in existence or on adjacent lands on the site, within twenty-five feet of the site's property lines, and in the full width of abutting public and private rights-of-way and easements.
- f. Location of all existing utilities (water, sewer, gas, electric, phone, cable, etc.), both above and below ground, on the site, on adjacent lands within twenty-five feet of the site's property lines and in the full width of abutting public rights-of-way; and
- g. Such additional existing physical elements information for the site and surrounding area as required by the director to complete review of a project subject to the standards of this chapter.

## 2. Additional Site Plan Information.

The following site plan information shall also be required for sites that include landslide-prone, flood-prone, riparian corridor, wetland and steep slope areas or their buffers. Information related to the location and boundaries of critical areas and required buffer delineations shall be prepared by qualified professionals with training and experience in their respective area of expertise as demonstrated to the satisfaction of the director.

- a. Location and boundaries of all critical areas and related buffers on the site and on adjacent lands within twenty-five feet of the site's property lines, noting both total square footage and percentage of site.
- b. Location and identification of all riparian corridors and wetlands within one hundred feet of the site's property lines.
- c. Location and boundaries of all proposed site improvements on the site, on adjacent lands within twenty-five feet of the site's property lines, and on the full width of abutting public and private rights-of-way and easements. This shall include the amount of proposed land

disturbing activities, including amounts of developmental coverage, impervious surfaces and construction activity areas (noting total square footage and percentage of site occupied).

- d. Location of all proposed grading activities and all proposed drainage control facilities or systems on the site or on adjacent lands within twenty-five feet of the site's property lines, and on the full width of abutting public and private rights-of-way and easements.
- e. Location of all proposed utilities (water, sewer, gas, electric, phone, cable, etc.), both above and below ground, on the site, on adjacent lands within twenty-five feet of the site's property lines, in the full width of abutting public rights-of-way, and any proposed extension required to connect to existing utilities, and proposed methods and locations for the proposed development to hook-up to these services; and
- f. Such additional site plan information related to the proposed development as required by the director to complete review of a project subject to the standards of this chapter.

### 3. Technical Reports.

Technical reports and other studies and submittals shall be prepared as required by the director detailing soils, geological, hydrological, drainage, plant ecology and botany, and other pertinent site information. The reports, studies and submittals shall be used to condition development to prevent potential harm and to protect the critical nature of the site, adjacent properties and the drainage basin.

Date Passed: Monday, December 3, 2007

Effective Date: Sunday, January 6, 2008

ORD C34147 Section 6

## [Title 17E](#) Environmental Standards

### [Chapter 17E.030](#) Floodplain Management

#### [Section 17E.030.060](#) Establishment of Development Permit

##### A. Development Permit Required.

A development permit shall be obtained before construction or development begins within any area of special flood hazard established in [SMC 17E.030.050\(B\)](#). The permit shall be for all structures including manufactured homes, as defined in [chapter 17A.020 SMC](#) and for all development, including fill and other activities also as defined in [chapter 17A.020 SMC](#).

##### B. A pre-development conference as set forth in [chapter 17G.061 SMC](#) is recommended (~~required~~) for all development proposed in areas identified as potential critical areas within the City of Spokane, including areas of special flood hazard established in [SMC 17E.030.050\(B\)](#).

##### C. Application for Floodplain Development Permit.

Application for a floodplain development permit shall be made on forms furnished by the City and may include, but not be limited to, plans in duplicate drawn to scale showing the nature, location, dimensions and elevations of the area in question: existing or proposed structures, fill, storage of materials, drainage facilities and the location of foregoing. Specifically, the following information is required:

1. Elevation in relation to mean sea level, of the lowest floor (including basement) of all structures recorded on a current elevation certificate with Section B completed by the Floodplain Administrator;
2. Elevation in relation to mean sea level to which any structure has been floodproofed;
3. Where a structure is to be floodproofed, certification by a registered professional engineer or architect that the floodproofing methods for any nonresidential structure meet the floodproofing criteria in [SMC 17E.030.130](#);
4. Description of the extent to which a watercourse will be altered or relocated as a result of proposed development;
5. A completed critical areas checklist as established at [chapter 17G.061 SMC](#);

6. A completed environmental checklist, unless the Floodplain Administrator as designated in [SMC 17E.030.070](#) has determined that the project is categorically exempt from [chapter 17E.050 SMC](#);
7. Where development is proposed in a floodway, an engineering analysis indication no rise of the Base Flood Elevation; and
8. Any other such information that may be reasonably required by the Floodplain Administrator in order to review the application, including all studies, reports and information required by reviewing departments or agencies to fully disclose potential environmental impacts of the proposal. These studies are required to demonstrate acceptance by the applicable department or agencies prior to the application being certified complete.

D. Fee Processing.

Floodplain development permits shall be processed as set forth in [chapter 17G.061 SMC](#).

E. Fee Schedule.

The fees for processing a floodplain development permit are set forth in [SMC 8.02.066\(F\)](#).

Date Passed: Monday, October 25, 2021

Effective Date: Thursday, December 2, 2021

ORD C36118 Section 3



## Title 17E Environmental Standards

### Chapter 17E.040 Spokane Geologically Hazardous Areas

#### Section 17E.040.080 Application Submittal Requirements

- A. A pre-development conference is recommended ((required)) for all regulated activities proposed in geologically hazardous areas and associated buffers per chapter 17G.061 SMC. The pre-development conference is intended to acquaint an applicant with standards, requirements, investigation procedures, best management practice and potential review procedures prior to making application.
- B. All activities identified in SMC 17E.040.050 shall meet the following application submittal requirements in addition to the application submittal requirements specified in other codes. The director may modify the submittal requirements based upon reasonable documentation, including BAS, needed to ensure compliance with this chapter, provided no construction activity, clearing or grading has taken place. A written summary of analysis and findings shall be included in any staff report or decision on the underlying permit.

#### 1. Topographic Survey.

A topographic site plan, prepared and stamped by a State of Washington licensed surveyor, is required for sites that include a geohazard or its buffer. The topographic site plan shall include the following existing physical elements:

- a. Existing topography at two-foot contour intervals on-site, on adjacent lands within twenty-five feet of the site's property lines, and on the full width of abutting public and private rights-of-way and easements.
- b. Terrain and stormwater-flow characteristics within the site, on adjacent sites within twenty-five feet of the site's property lines, and on the full width of abutting public and private rights-of-way and easements.
- c. Location of areas with significant amounts of vegetation, and specific location and description of all trees with trunks six inches or greater in diameter measured four feet, six inches above the ground, and noting their species.
- d. Location and boundaries of all existing site improvements on the site, on adjacent lands within twenty-five feet of the site's property lines, and on the full width of abutting public and private rights-of-way and easements.

easements. This shall include the amounts of developmental coverage, including all impervious surfaces (noting total square footage and percentage of site occupied).

- e. Location of all grading activities in progress, and all natural and artificial drainage control facilities or systems in existence or on adjacent lands on the site, within twenty-five feet of the site's property lines, and in the full width of abutting public and private rights-of-way and easements.
- f. Location of all existing utilities (water, sewer, gas, electric, phone, cable, etc.), both above and below ground, on the site, on adjacent lands within twenty-five feet of the site's property lines and in the full width of abutting public rights-of-way; and
- g. Such additional existing physical elements information for the site and surrounding area as required by the director to complete review of a project subject to the standards of this chapter.

## 2. Additional Site Plan Information.

The following site plan information shall also be required for sites that include landslide-prone, flood-prone, riparian corridor, wetland and steep slope areas or their buffers. Information related to the location and boundaries of critical areas and required buffer delineations shall be prepared by qualified professionals with training and experience in their respective area of expertise as demonstrated to the satisfaction of the director.

- a. Location and boundaries of all critical areas and related buffers on the site and on adjacent lands within twenty-five feet of the site's property lines, noting both total square footage and percentage of site.
- b. Location and identification of all riparian corridors and wetlands within one hundred feet of the site's property lines.
- c. Location and boundaries of all proposed site improvements on the site, on adjacent lands within twenty-five feet of the site's property lines, and on the full width of abutting public and private rights-of-way and easements. This shall include the amount of proposed land disturbing activities, including amounts of developmental coverage, impervious surfaces and construction activity areas (noting total square footage and percentage of site occupied).
- d. Location of all proposed grading activities and all proposed drainage control facilities or systems on the site or on adjacent lands within

twenty-five feet of the site's property lines, and on the full width of abutting public and private rights-of-way and easements.

- e. Location of all proposed utilities (water, sewer, gas, electric, phone, cable, etc.), both above and below ground, on the site, on adjacent lands within twenty-five feet of the site's property lines, in the full width of abutting public rights-of-way, and any proposed extension required to connect to existing utilities, and proposed methods and locations for the proposed development to hook-up to these services; and
- f. Such additional site plan information related to the proposed development as required by the director to complete review of a project subject to the standards of this chapter.

### 3. Technical Reports.

Technical reports and other studies and submittals, including the geohazard evaluation and mitigation plan described in [SMC 17E.040.090](#) below, shall be prepared as required by the director detailing soils, geological, hydrological, drainage, plant ecology and botany, and other pertinent site information. The reports, studies and submittals shall be used to condition development to prevent potential harm and to protect the critical nature of the site, adjacent properties and the drainage basin.

Date Passed: Monday, December 3, 2007

Effective Date: Sunday, January 6, 2008

ORD C34149 Section 8

## Title 17E Environmental Standards

### Chapter 17E.070 Wetlands Protection

#### Section 17E.070.080 Application Submittal Requirements

- A. A pre-development conference is recommended (~~required~~) for all regulated activities proposed in potential wetland areas and associated buffers per chapter 17G.061 SMC. The pre-development conference is intended to acquaint an applicant with standards, requirements, investigation procedures, best management practice, and potential review procedures prior to submitting an application.
- B. All activities identified in SMC 17E.070.040 shall meet the following application submittal requirements in addition to the application submittal requirements specified in other codes. The director may modify the submittal requirements based upon reasonable documentation, including BAS, needed to ensure compliance with this chapter, provided no construction activity, clearing, or grading has taken place. A written summary of analysis and findings shall be included in any staff report or decision on the underlying permit.
1. Wetlands Report. This report shall include a written assessment and accompanying maps of the impacted wetland including, at a minimum, wetland delineation and rating as determined by SMC 17E.070.100; existing wetland acreage; proposed wetland impacts; alternatives to wetlands impacts; proposed wetland buffer; vegetative, faunal and hydrological characteristics; soil and substrate conditions and topographic elevations; and shall be submitted as a part of the permit application.
  2. Topographic Survey. To the extent not provided in the wetlands report, a topographic site plan, prepared and stamped by a State of Washington licensed surveyor, is required for sites that include a wetland or its buffer. The topographic site plan shall include the following existing physical elements:
    - a. Existing topography at two-foot contour intervals on-site, on adjacent lands within twenty-five feet of the site's property lines, and on the full width of abutting public and private rights-of-way and easements;
    - b. Terrain and stormwater-flow characteristics within the site, on adjacent sites within twenty-five feet of the site's property lines, and on the full width of abutting public and private rights-of-way and easements;

- c. Location of areas with significant amounts of vegetation, and specific location and description of all trees with trunks six inches or greater in diameter at breast height (dbh) measured four feet, six inches above the ground, and noting their species;
  - d. Location and boundaries of all existing site improvements on the site, on adjacent lands within twenty-five feet of the site's property lines, and on the full width of abutting public and private rights-of-way and easements. This shall include the amounts of developmental coverage, including all impervious surfaces (noting total square footage and percentage of site occupied);
  - e. Location of all ongoing grading activities as well as all natural and artificial drainage control facilities or systems in existence on the site or on adjacent lands, within twenty-five feet of the site's property lines, and in the full width of abutting public and private rights-of-way and easements;
  - f. Location of all existing utilities (water, sewer, gas, electric, phone, cable, etc.), both above and below ground, on the site, on adjacent lands within twenty-five feet of the site's property lines and in the full width of abutting public rights-of-way; and
  - g. Additional information on existing physical elements on the site and surrounding area as required by the director to inform a complete review of a project subject to the standards of this chapter.
3. Additional Site Plan Information. To the extent not provided in the wetlands report, the following site plan information shall also be required for sites that include wetlands and their buffers. Information related to the location and boundaries of wetlands and required buffer delineations shall be prepared by qualified professionals with training and experience in their respective area of expertise as demonstrated to the satisfaction of the director.
- a. Location and boundaries of all wetlands and wetland buffer on the site and on adjacent lands within twenty-five feet of the site's property lines, noting both total square footage and percentage of site;
  - b. Location and identification of all wetlands within one hundred feet of the site's property lines;

- c. Location and boundaries of all proposed site improvements on the site, on adjacent lands within twenty-five feet of the site's property lines, and on the full width of abutting public and private rights-of-way and easements. This shall include the amount of proposed land disturbing activities, including amounts of developmental coverage, impervious surfaces and construction activity areas (noting total square footage and percentage of site occupied);
  - d. Location of all proposed grading activities and all proposed drainage control facilities or systems on the site or on adjacent lands within twenty-five feet of the site's property lines, and on the full width of abutting public and private rights-of-way and easements;
  - e. Location of all proposed utilities (water, sewer, gas, electric, phone, cable, etc.), both above and below ground, on the site, on adjacent lands within twenty-five feet of the site's property lines, in the full width of abutting public rights-of-way, and any proposed extension required to connect to existing utilities, and proposed methods and locations for the proposed development to hook-up to these services; and
  - f. Such additional site plan information related to the proposed development as required by the director to inform a complete review of a project subject to the standards of this chapter.
4. Technical Reports. To the extent not provided in the wetlands report, technical reports and other studies and submittals shall be prepared as required by the director detailing on site soils, geology, hydrology, drainage, plant ecology and botany, and other pertinent site information. The reports, studies and submittals shall be used to condition development to prevent potential harm and to protect the critical nature of the site, adjacent properties, and the drainage basin.

Date Passed: Monday, June 19, 2017

Effective Date: Sunday, July 30, 2017

ORD C35508 Section 7

## Title 17G Administration and Procedures

### Chapter 17G.061 Land Use Application Procedures

#### Section 17G.061.110 Application Requirements

##### A. Predevelopment Meeting.

###### 1. Purpose.

Predevelopment meetings are not intended to be an exhaustive review of all regulations or potential issues for a given application. Predevelopment meetings have two purposes:

- a. acquaint City staff and other agencies with a proposed development and to generally advise the applicant of applicable regulations, design guidelines and design review processes, and policies impacting the proposal; and
  - b. acquaint the applicant with the applicable provisions of these procedures, minimum submission requirements and other plans or regulations which may impact the proposal.
2. The City may, when applicable, apply additional relevant laws to the application subsequent to a predevelopment meeting.
  3. ~~((Predevelopment meetings are required for any development proposal in the central business district. The Planning Director or Building Official, as appropriate, may waive this requirement.))~~
  4. Predevelopment meetings are recommended for Type II and III applications, and Type I project permit applications in the centers and corridors (CC) zones.

##### B. Community Meeting.

All Type III applications and Type II applications where indicated in [Table 17G.061.010-1](#) are required to hold a community meeting regarding the proposed application. The applicant or their representative shall conduct the community meeting.

1. Timing.

The meeting shall occur no more than one hundred twenty days prior to application and before the application is accepted by the City.

2. Notice.

Notice for the community meeting shall be posted fourteen days prior to the meeting. Public notice of a community meeting shall be provided as required in [SMC 17G.061.210](#).

3. Combining with Traffic Study.

When a traffic study is required as a part of an application, the scoping meeting for a traffic study may be combined with the community meeting.

4. Meeting Summary.

The applicant shall provide a summary of the meeting at the time of submission of the application. Other attendees of the community meeting may also submit a summary of the meeting issues to the decision-maker. The meeting summary shall consist of the following:

- a. A digital recording of the meeting proceedings; and
- b. List of attendees; and
- c. A copy of the notice of community meeting; and
- d. Affidavits of posting/ mailing the notice.

C. General Requirements.

Applications shall include the following:

1. Predevelopment meeting summary, if required under subsection (A).
2. Filing fees as required under [chapter 8.02 SMC](#).
3. Application documents supplied by the City, including but not limited to:



- a. General application form;
  - b. Supplemental application form;
  - c. Environmental checklist, if required under [chapter 17E.050 SMC](#);
4. A site plan drawn to scale showing:
  - a. Property dimensions;
  - b. location and dimensions of all existing and proposed physical improvements;
  - c. location and type of landscaping;
  - d. walkways and pedestrian areas;
  - e. off-street parking areas and access drives;
  - f. refuse facilities; and
  - g. significant natural features, such as slopes, trees, rock outcrops, and critical areas.
5. Required copies of documents, plans, or maps (as set forth in the application checklist).
6. Written narrative identifying consistency with the applicable policies, regulations, and criteria for approval of the permit requested.
7. Other plans, such as building elevations, landscaping plans, or sign plans, which are determined by the permitting department to be necessary to support the application.
8. Additional application information as requested by the permitting department, which may include, but is not limited to, the following:
  - a. geotechnical studies;
  - b. hydrologic studies;

- c. critical area studies;
- d. noise studies;
- e. air quality studies;
- f. visual analysis; and
- g. transportation impact studies.

#### D. Additional Requirements

The following Type II and III applications shall meet these requirements in addition to the provisions of subsection (B) of this section:

1. Shoreline – Substantial Development Permit, Conditional Use Permit and Variance.
  - a. Name, address, and phone number of the applicant. The applicant should be the owner of the property or the primary proponent of the project and not the representative of the owner or primary proponent.
  - b. Name, address, and phone number of the applicant's representative if other than the applicant.
  - c. Name, address, and phone number of the property owner, if other than the applicant.
  - d. Location of the property. This shall, at a minimum, include the property address and identification of the section, township and range to the nearest quarter, quarter section or latitude and longitude to the nearest minute.
  - e. Identification of the name of the shoreline (water body) with which the site of the proposal is associated.
  - f. General description of the proposed project that includes the proposed use or uses and the activities necessary to accomplish the project.
  - g. General description of the property as it now exists, including its physical characteristics and improvements and structures.

- h. General description of the vicinity of the proposed project, including identification of the adjacent uses, structures and improvements, intensity of development and physical characteristics.
- i. A site development plan consisting of maps and elevation drawings, drawn to an appropriate scale to depict clearly all required information, photographs and text which shall include:
  - i. the boundary of the parcels(s) of land upon which the development is proposed;
  - ii. the ordinary high-water mark of all water bodies located adjacent to or within the boundary of the project. This may be an approximate location, provided that for any development where a determination of consistency with the applicable regulations requires a precise location of the ordinary high-water mark, the mark shall be located precisely and the biological and hydrological basis for the location as indicated on the plans shall be included in the development plan. Where the ordinary high-water mark is neither adjacent to or within the boundary of the project, the plan shall indicate the distance and direction to the nearest ordinary high-water mark of a shoreline;
  - iii. existing and proposed land contours. The contours shall be at intervals sufficient to accurately determine the existing character of the property and the extent of proposed change to the land that is necessary for the development. Areas within the boundary that will not be altered by the development may be indicated as such and contours approximated for that area;
  - iv. a delineation of all wetland areas that will be altered or used as a part of the development;
  - v. the dimensions and locations of all existing and proposed structures and improvements, including but not limited to: buildings, paved or graveled areas, roads, utilities, material stockpiles or surcharge, and stormwater management facilities;

- vi. an inventory of the existing vegetation on the proposed project site, including the location, type, size, and condition, pursuant to [SMC 17E.060.240](#), Shoreline Vegetation Inventory;
- vii. a landscape plan prepared and stamped by a licensed landscape architect, registered in the state of Washington;
- viii. where applicable, plans for development of areas on or off the site as mitigation for impacts associated with the proposed project shall be included;
- ix. quality, source and composition of any fill material that is placed on the site, whether temporary or permanent;
- x. quantity, composition and destination of any excavated or dredged material;
- xi. vicinity map showing the relationship of the property and proposed development or use to roads, utilities, existing developments, and uses on adjacent properties;
- xii. where applicable, a depiction of the impacts to views from existing residential uses;
- xiii. on all variance applications, the plans shall clearly indicate where development could occur without the approval of a variance, the physical features and circumstances of the property that provide a basis for the request, and the location of adjacent structures and uses.

## 2. Certificate of Compliance.

- a. Site plan is to be prepared by a licensed surveyor; and
- b. Copies of building permits or other data necessary to demonstrate the building was erected in good faith and all reasonable efforts comply with the code.

## 3. Plans-in-lieu of Compliance.

- a. Alternative development plan designed in conformance with the applicable development regulations; and
  - b. A written narrative of how the proposed development plan is superior, or more innovative, or provides greater public benefit.
4. Preliminary Plat, Short Plat, and Binding Site Plan. As provided in [chapter 17G.080 SMC](#).
5. PUD.
  - a. Profiles of any structures more than one story, shown in relation to finished grade.
  - b. Location, dimension, and boundary of proposed open space.
  - c. Site plan demonstrating compliance with Title 17C SMC including signs, off-street parking, structure height, building coverage, yards, density, screening, buffering, and lighting.
6. Skywalk.
  - a. A legal description of airspace to be occupied.
  - b. Architectural and engineering plans.
  - c. Artist's rendering of the proposed skywalk; and
  - d. Written narrative of the access for the public from the street, other buildings, and other skywalks.
  - e. Acceptance of the final design review recommendations.
  - f. Location and design of all wayfinding signage to be placed to ensure public access.
7. Floodplain – Floodplain Development Permit and Variance.

As provided in [chapter 17E.030 SMC](#).

Date Passed: Monday, November 20, 2023

Effective Date: Monday, January 1, 2024

ORD C36459 Section 35

## Title 17G Administration and Procedures

### Chapter 17G.061 Land Use Application Procedures

#### A. Determination of Completeness.

Within twenty-eight days of receiving a project permit application, the department shall determine if the application is technically complete (RCW 36.70B.070) as outlined on the project permit application. Additional information or studies may be required, or project modifications may be undertaken subsequent to the technical review of the application by the City.

1. The number of days is measured by counting every calendar day.

2. If a written determination to the contrary is not provided by the 29<sup>th</sup> day, the application shall be deemed technically complete. However, this does not prevent the City from requesting additional information or studies after the application is deemed technically complete.

#### B. Procedures for Determination of Completeness.

The following steps outline the process for the department to determine that an application is complete.

##### 1. Counter Complete.

The department shall conduct a preliminary, immediate review to determine if the application filed with the City contains the documents and information required by SMC 17G.061.110. If the department determines the application does not contain the required documents and information, the application including fees shall be returned to the applicant.

##### 2. Component Screening.

If the application appears to contain required documents, the department shall accept the application and within seven days, conduct a detailed review and determine if any additional information is necessary to process the application. If the department determines the application is missing required components, or is inadequate in other ways, ~~the application including any fees shall be returned to~~

~~the applicant. the applicant shall be sent a written determination outlining the necessary components that are needed to make the application counter complete.~~

~~a. If the department issues a second request for corrections or information, staff may schedule a meeting to meet with the applicant to attempt to resolve the outstanding issues. The meeting must be scheduled within 14 days of the second request.~~

~~b. If a meeting does not resolve the issues and the department proceeds with a third request for additional information or corrections, the application must be approved or denied upon receiving the additional information or corrections.~~

### 3. Review by Interested Agencies.

If the application, after the detailed review, is found to contain the required components and supporting documents, the application and supporting documents shall be forwarded to (i) interested City departments, (ii) agencies of local, state, or federal governments that may have jurisdiction over some aspect of the application, and (iii) the individual(s) designated pursuant to SMC 4.27.010(D) to receive written notice on behalf of the neighborhood council in which the project is located and to any neighborhood council whose geographic boundaries are located within a 600-foot radius of the project, at the address for such departments, agencies, and neighborhood council designee(s) on file with the department, for review to ensure compliance with state laws, ordinances and concurrency requirements. Interested departments, agencies, and the neighborhood council shall be given fourteen days to provide comments on a permit application. All written comments will be forwarded to the applicant at the end of the fourteen day comment period. Comments submitted after the fourteen day comment period will be forwarded to the applicant, subject to RCW 36.70B.070.

~~a. If review agencies require additional information to continue processing the application, the applicant shall be notified in writing.~~

~~b. Required information must be provided within sixty days from the notification by the department. The applicant may submit a written request for additional time to the director; any time extensions shall be in writing. If the information is not received within the sixty days (or as otherwise agreed to), the application and a portion of the fees shall be returned to the applicant, pursuant to chapter 8.02 SMC.~~

~~c. Within fourteen days of the submission of the additional information identified by the review agency, the department shall notify the applicant whether the studies are adequate or what additional information is necessary.~~



~~d. If the neighborhood council submits written comments on an application, the department shall provide a written response to the chairperson, with copy to the applicant, no later than the date on which the application is certified complete pursuant to paragraph D herein below.~~

4. a. Application Certified Complete. Certification.

~~Within seven days of the expiration of the interested agency comment period, ((if no additional information was required, or the information required under subsection (3) is acceptable,)) the department shall provide a written determination stating either that the application is technically complete or that the application is technically incomplete. ((certify the application complete. Applications requiring review by the hearing examiner are forwarded to the hearing examiner upon being certified as complete.))~~

~~((a-))~~ i. If review agencies require additional information to continue processing the application, the applicant shall be notified in writing.

~~((b-))~~ ii. Required information must be provided within sixty days from the notification by the department. The applicant may submit a written request for additional time to the director; any time extensions shall be in writing. If the information is not received within the sixty days (or as otherwise agreed to), the application and a portion of the fees shall be returned to the applicant, pursuant to chapter 8.02 SMC.

~~((c-))~~ iii. Within fourteen days of the submission of the additional information identified by the review agency, the department shall notify the applicant whether the studies are adequate or what additional information is necessary.

~~((d-))~~ iv. If the neighborhood council submits written comments on an application, the department shall provide a written response to the chairperson, with copy to the applicant, no later than the date on which the application is certified complete pursuant to paragraph D herein below.

4. Technically Complete Application

1. Within seven days of the expiration of the interested agency comment period, if no additional information was required, or the information required under subsection (3) is acceptable, the department shall provide a written determination stating either that the application is certified as technically complete or still technically incomplete.

5. Notice of Application.

Within fourteen days of the issuance of a determination of a complete application, a notice of application shall be provided for Type I, II and III project permit applications in accordance with this section (RCW 36.70B.110.2), except that notice of application is not required for short subdivision applications involving minor engineering review as defined in SMC 17G.080.040(C)(2). The notice of application shall follow the public notice requirements contained in SMC 17G.061.210. The notice of application may be combined with the notice of public hearing, if a hearing has been scheduled by notice of application. The date, time, place and type of hearing, SEPA determination and SEPA appeal deadline (using the optional DNS process) are required to be added to the notice of application if this provision is used (RCW 36.70B.110(2)(f)).

#### 6. Vesting.

Applications shall be considered vested at the time the application is ~~((certified))~~ complete and all fees have been paid, the vesting date shall be the date of application submission. If the application is not complete when filed or information is not timely provided as set forth in subsection (2) or (3), the application shall not be considered complete for purposes of vesting or other statutory compliance dates.

##### a. Expiration of Vested applications

1. Vested applications remain in effect unless no action is taken to complete the project and the date of expiration is reached. A list of permit expiration dates can be found in [Table 17G.061.010-1](#).

Date Passed: Monday, November 20, 2023

Effective Date: Monday, January 1, 2024

ORD C36459 Section 35

Title 17G Administration and Procedures

Chapter 17G.061 Land Use Application Procedures

Section 17G.061.130 Application Time Limits

A. A decision on permit applications subject to this chapter shall ~~((be made within one hundred twenty days of submission of a complete application as set forth in SMC 17G.061.130.))~~ not exceed the following for each type of permit (RCW 36.70B.080:

1. 65 days for permits which do not require public notice.
2. 100 days for permits which require public notice, and
3. 170 days for permits which require public notice and a public hearing.
4. The number of days is measured by counting every calendar day.
5. A summary of the application types and requirements can be found in Table 17G.061.010.

B. ~~((The following shall be excluded when calculating this time period:))~~ The number of days an application is in review with the City shall be calculated from the day the application is deemed technically complete as determined under RCW 36.70B.070 to date a final decision is issued on the project permit application. The number of days shall be calculated by counting every calendar day and excluding the following time periods:

1. Any period during which the applicant has been requested by the department to correct plans, perform required studies, or provide additional required information due to the applicant's inaccurate or insufficient information and the day when additional information is submitted by the applicant.
2. Any period during which an environmental impact statement is being prepared.
3. Any period for administrative appeals of land use permits.
4. ~~((Any extension for any reasonable period mutually agreed upon in writing between the applicant and the department (RCW 36.70B.080(1)).))~~ Time periods may be extended for 30 days in the following cases:

a. If the applicant informs the City in writing that the applicant would like to suspend the review of the project for more than 60 days; or

b. If the applicant is not responsive for more than 60 consecutive days after the additional information has been requested to further process the application.

5. If the permit requires approval of a new fully contained community as provided in RCW 36.70A.350, or a master planned resort as provided in RCW 36.70A.360, or the siting of an essential public facility as provided in RCW 36.70A.200.

6. The time periods shall start over if an applicant proposes a substantial modification to an application as described in Section 17G.061.150 Modification of Applications and Permits.

7. Annual amendments to the comprehensive plan are not subject to the requirements of this section.

C. The City may, by adoption of an ordinance or resolution, modify the time periods to add permit types, change permit names or types in each category, address how consolidated review time frames may be different than permits submitted individually and address how projects of a certain size or type may be differentiated as provided for in RCW 36.70B.140.

Date Passed: Monday, November 20, 2023

Effective Date: Monday, January 1, 2024

ORD C36459 Section 35

## Title 17G Administration and Procedures

### Chapter 17G.061 Land Use Application Procedures

#### Section 17G.061.150 Modification of Applications and Permits

##### A. Modification of Complete Application.

1. Proposed modifications to an application, which the department has previously found to be complete, will be treated as follows:
  - a. Minor ((M)) modifications proposed by the department to an application shall not be considered a new application.
  - b. If the applicant proposes substantial modifications to an application, as determined by the department, the application may be considered a new application. The new application shall conform to the requirements of all statutes and ordinances in effect at the time the new application is submitted. A substantial modification may include but is not limited to the following:
    - i. change in use;
    - ii. increase in density;
    - iii. increase in site area; or
    - iv. changes that increase or significantly modify the traffic pattern for the proposed development.

##### B. Limitations on Refiling of Application.

1. Applications for a land use permit pursuant to Title 17 SMC on a specific site shall not be accepted if a similar permit has been denied on the site within the twelve months prior to the date of submittal of the application. The date of denial shall be considered the date the decision was made on an appeal, if an appeal was filed or the date of the original decision if no appeal was filed.
2. The twelve-month time period may be waived or modified if the director finds that special circumstances warrant earlier reapplication. The director shall consider the following in determining whether an application for permit is similar to, or substantially the same as, a previously denied application:

- a. An application for a permit shall be deemed similar if the proposed use of the property is the same, or substantially the same, as that which was considered and disallowed in the earlier decision.
- b. An application for a permit shall be deemed similar if the proposed application form and site plan (i.e., building layout, lot configuration, dimensions) are the same, or substantially the same, as that which was considered and disallowed in the earlier decision; and
- c. An application for a variance, exception, or waiver shall be deemed similar if the special circumstances which the applicant alleges as a basis for the request are the same, or substantially the same, as those considered and rejected in the earlier decision. In every instance, the burden of proving that an application is not similar shall be upon the applicant.

#### C. Modifications or Revisions to Shoreline Permits.

1. A permit revision is required whenever the applicant proposes substantive changes to the design, terms, or conditions of a project from that which is approved in the permit. Changes are substantive if they materially alter the project in a manner that relates to its conformance to the terms and conditions of the permit, the shoreline master program and/or the policies and provisions of chapter 90.58 RCW.
2. Changes which are not substantive in effect do not require approval of a revision. When an applicant seeks to revise a permit, the director shall request from the applicant detailed plans and text describing the proposed changes in the permit.
3. If the director determines that the proposed changes are within the scope and intent of the original permit as defined in WAC 173-27-100(2) and are consistent with the shoreline master program and the Shoreline Management Act, the director may approve a revision.
4. If the proposed changes are not within the scope and intent of the original permit, the applicant shall apply for a new permit in the manner provided for in this chapter.
5. Revisions to permits may be authorized after original permit authorization has expired under RCW 90.58.143. The purpose of such revisions shall be limited to authorization of changes which are consistent with WAC 173-27 and which would not require a permit for the development or change proposed under the terms of the Shoreline Management Act, this section and the shoreline master program. If the proposed change constitutes substantial

development then a new permit is required. This shall not be used to extend the time requirements or to authorize substantial development beyond the time limits of the original permit.

6. If the sum of the revision and any previously approved revisions under former WAC 173-14-064 or WAC 173-27-100 violate the provisions that they are “within the scope and intent of the original permit,” the director shall require that the applicant apply for a new permit.
7. The revision approval, including the revised site plans and text consistent with the provisions of WAC 173-27-180 as necessary to clearly indicate the authorized changes, and the final ruling on consistency with this section shall be filed with the department of ecology. In addition, the director shall notify parties of record of their action.
8. If the revision to the original permit was a conditional use or variance, which was conditioned by the department of ecology, the director shall submit the revision to the department of ecology for its approval, approval with conditions, or denial, indicating that the revision is being submitted under the requirements of this section. Ecology shall render and transmit to the City and the applicant its final decision within fifteen days of the date of the department of ecology’s receipt of the submittal from the director. The director shall notify parties of record of the department of ecology’s final decision.
9. The revised permit is effective immediately upon final decision by the director, or when reviewed by the department of ecology, pursuant to subsection (7), then upon final action by the department of ecology.
10. Appeals shall be in accordance with RCW 90.58.180 and shall be filed with the shorelines hearings board within twenty-one days from the date of receipt of the revision approved by the director, or when appropriate under subsection (7), the date ecology’s final decision is transmitted to the City and the applicant. Appeals shall be based only upon contentions of noncompliance with the provisions of subsection (2). Construction undertaken pursuant to that portion of a revised permit not authorized under the original permit is at the applicant’s own risk until the expiration of the appeals deadline. If an appeal is successful in proving that a revision is not within the scope and intent of the original permit, the decision shall have no bearing on the original permit.

#### D. Modification to a Building Permit Subject to a Type II or III Approval.

In issuing building permits for construction under an approved site plan, the building official may, with concurrence of the Planning Director , permit minor adjustments of the location and/or dimensions of buildings, parking areas, and roadways as long

as such adjustments do not change any points of ingress or egress to the site unless approved by the director of engineering services, change any perimeter setbacks, or exceed the density authorized in the permit. No modification of an approved application may be considered approved unless specifically provided in writing.

1. The Planning Director may, without public notice, modify an approved site plan, if all the following criteria are met:
  - a. The use will remain the same.
  - b. The total site coverage or total area covered by buildings will not increase.
  - c. The use will continue to comply with all conditions of approval imposed by the original decision.
  - d. The use will comply with all of the requirements of the land use regulations applicable to it and the property on which it is or will be located.
2. Any modification of an approved site plan not consistent with the standards of subsection (B)(1) of this section may be approved only pursuant to the procedures for granting the original Type II or III approval.

#### E. Modification of Shoreline Permit.

1. Recision and Remanding of Shoreline Permit.
  - a. After providing notice to the permittee and the public and also holding a public meeting, the Planning Director may rescind or suspend a permit if any of the conditions in RCW 90.58.140(8) exist.
  - b. Under the conditions listed in RCW 90.58.180, shoreline permits may be remanded back to the City by the Shorelines Hearings Board.
2. Other Modification of Shoreline Permit.
  - a. A permit revision is required whenever the applicant proposes substantive changes to the design, terms, or conditions of a project from that which is approved in the permit. Changes are substantive if they materially alter the project in a manner that relates to its conformance to the terms and conditions of the permit, the shoreline master program and/or the policies and provisions of chapter 90.58 RCW.



- b. Changes which are not substantive in effect do not require approval of a revision. When an applicant seeks to revise a permit, the director shall request from the applicant detailed plans and text describing the proposed changes in the permit.
- c. If the director determines that the proposed changes are within the scope and intent of the original permit as defined in WAC 173-27-100(2) and are consistent with the shoreline master program and the Shoreline Management Act, the director may approve a revision.
- d. If the proposed changes are not within the scope and intent of the original permit, the applicant shall apply for a new permit in the manner provided for in this chapter.
- e. Revisions to permits may be authorized after original permit authorization has expired under RCW 90.58.143. The purpose of such revisions shall be limited to authorization of changes which are consistent with WAC 173-27 and which would not require a permit for the development or change proposed under the terms of the Shoreline Management Act, this section and the shoreline master program. If the proposed change constitutes substantial development then a new permit is required. This shall not be used to extend the time requirements or to authorize substantial development beyond the time limits of the original permit.
- f. If the sum of the revision and any previously approved revisions under former WAC 173-14-064 or WAC 173-27-100 violate the provisions that they are "within the scope and intent of the original permit," the director shall require that the applicant apply for a new permit.
- g. The revision approval, including the revised site plans and text consistent with the provisions of WAC 173-27-180 as necessary to clearly indicate the authorized changes, and the final ruling on consistency with this section shall be filed with the department of ecology. In addition, the director shall notify parties of record of their action.
- h. If the revision to the original permit was a conditional use or variance, which was conditioned by the department of ecology, the director shall submit the revision to the department of ecology for its approval, approval with conditions, or denial, indicating that the revision is being submitted under the requirements of this section. Ecology shall render and transmit to the City and the applicant its final decision within fifteen days of the date of the department of ecology's receipt of the submittal from the director. The director shall notify parties of record of the department of ecology's final decision.

- i. The revised permit is effective immediately upon final decision by the director, or when reviewed by the department of ecology, pursuant to subsection (7), then upon final action by the department of ecology.
- j. Appeals shall be in accordance with RCW 90.58.180 and shall be filed with the shorelines hearings board within twenty-one days from the date of receipt of the revision approved by the director, or when appropriate under subsection (7), the date ecology's final decision is transmitted to the City and the applicant. Appeals shall be based only upon contentions of noncompliance with the provisions of subsection (2). Construction undertaken pursuant to that portion of a revised permit not authorized under the original permit is at the applicant's own risk until the expiration of the appeals deadline. If an appeal is successful in proving that a revision is not within the scope and intent of the original permit, the decision shall have no bearing on the original permit.

Date Passed: Monday, November 20, 2023

Effective Date: Monday, January 1, 2024

ORD C36459 Section 35

## Title 17G Administration and Procedures

### Chapter 17G.080 Subdivisions

#### Section 17G.080.040 Short Subdivisions

##### A. Predevelopment Meeting

A predevelopment meeting (~~((is required if the proposal is located in the central business district, unless waived by the director, and))~~) is recommended for all other proposals prior to submittal of the application. The purpose of a predevelopment meeting is to acquaint the applicant with the applicable provisions of this chapter, minimum submission requirements and other plans or regulations, which may impact the proposal.

##### B. Preliminary Short Plat Application and Map Requirements

1. Applications for approval of a preliminary short subdivision shall be filed with the director. All applications shall be submitted on forms provided for such purpose by the department. The director may waive specific submittal requirements determined to be unnecessary for review of the application. The application shall include the following:
  - a. The general application.
  - b. The supplemental application.
  - c. The environmental checklist, if required under [chapter 17E.050 SMC](#).
  - d. Title report no older than thirty days from issuance from the title company.
  - e. The filing fees as required under [chapter 8.02 SMC](#).
  - f. The required number of documents, plans or maps drawn to a minimum scale of one-inch equals one hundred feet, on a sheet twenty-four by thirty-six inches, as set forth in the application checklist.

- g. A written narrative identifying consistency with the applicable policies, regulations and criteria for approval of the permit requested; and
- h. Additional application information which may be requested by the permitting department and may include, but is not limited to, the following: geotechnical studies, hydrologic studies, critical area studies, noise studies, air quality studies, visual analysis and transportation impact studies.
- i. One copy of the predevelopment conference notes (if applicable); and
- j. One copy of the notification district map.

## 2. Contents of Preliminary Short Plat Map

The preliminary short plat shall be prepared by a land surveyor and shall show the following:

- a. Plat name and the name of any subdivision to be replatted.
- b. The name, mailing address and phone number of the owner and the person with whom official contact should be made regarding the application.
- c. Surveyor's name, mailing address, and phone number.
- d. Legal description.
- e. Section, township, and range
- f. Vicinity map.
- g. North arrow, scale and date.
- h. Datum plane.
- i. Acreage.
- j. Number of lots, proposed density, and number of housing units.

- k. Zoning designation.
- l. The boundary lines of the proposed subdivision.
- m. City limits and section lines.
- n. Park or open space (if proposed).
- o. Existing topography at two-foot maximum interval.
- p. The boundaries and approximate dimensions of all blocks and lots, along with the following information:
  - i. the numbers proposed to be assigned each lot and block;
  - ii. the dimensions, square footage, and acreage of all proposed lots and tracts; and
  - iii. for residential lots zoned R1 or R2, the proposed Middle Housing types, included single-unit detached houses, and total number of proposed units on all proposed lots.
- q. Proposed names of streets.
- r. The location and widths of streets, alleys, rights-of-way, easements (both public and private), turn around and emergency access, parks and open spaces.
- s. Conditions of adjacent property, platted or unplatted, and if platted, giving the name of the subdivision. If the proposed short plat is the subdivision of a portion of an existing plat, the approximate lines of the existing plat are to be shown along with any and all recorded covenants and easement
- t. The names and address of the record owners and taxpayers of each parcel adjoining the subdivision.
- u. Indicate any street grades in excess of eight percent.
- v. The location and, where ascertainable, sizes of all permanent buildings, wells, wellhead protection areas, sewage disposal systems, water courses, bodies of water, flood zones, culverts,

bridges, structures, overhead and underground utilities, railroad lines, and other features existing upon, over or under the land proposed to be subdivided, and identifying any which are to be retained or removed.

- w. Proposed one-foot strips for right-of-way conveyed to the City, in cases where a proposed public street or alley abuts unplatted land.
- x. If a body of water forms the boundary of the plat, the ordinary high water mark as defined in chapter 90.58 RCW.
- y. Critical areas as defined in chapters [17E.020](#), [17E.030](#), [17E.070](#) and [17G.030 SMC](#).
- z. Significant historic, cultural or archaeological resources; and
- aa. If the proposal is located in an irrigation district, the irrigation district name.

### C. Review of Preliminary Short Plat

1. The application shall be reviewed in accordance with the procedures set forth in chapter 17G.061 SMC for a Type II application, except an application that meets the requirements for minor engineering review as provided in subsection (2) of this section shall be excluded from the public notice requirements contained in SMC 17G.06210 and public comment period under SMC 17G.061.220.
2. Minor Engineering Review.
  - a. A preliminary short plat application may qualify for a Minor Engineering Review if it meets all of the following conditions:
    - i. The application is categorically exempt from chapter 43.21C RCW (SEPA);
    - ii. There is direct water and sewer main lot frontage on an existing and improved public right-of-way;
    - iii. No extensions of public water, sewer, or other utility services will be needed;

- iv. No public easements for water, sewer, or other utility service exists on the lot;
  - v. The lot is not situated in a Special Drainage District as defined in [SMC 17D.060.130](#); and
  - vi. Public utility mains do not exist on the lot.
- b. The City Engineer is authorized to waive conditions ii through vi of the subsection (a) if the application substantially meets the intent of the Minor Engineering Review.

#### D. Public Notice And Public Comment.

All public notice of the application and opportunities for public comment shall be given in accordance with the procedures set forth in [chapter 17G.061 SMC](#) for a Type II application.

##### 1. Exceptions.

- a. A short plat that meets the requirements of Minor Engineering Review as provided in subsection (C)(2) of this section shall not require a notice of application.
- b. A short plat that is categorically exempt from SEPA and results in four or fewer lots shall not require a posted or signed notice of application.

#### E. Preliminary Short Plat Approval Criteria.

Prior to approval of a short plat application, the director shall find the application to be in the public use and interest, conform to applicable land use controls and the comprehensive plan of the City, and the approval criteria set forth in [chapter 17G.061 SMC](#). The director has the authority to approve or disapprove a proposed preliminary short plat under the provisions of this chapter, subject to appeal as provided in [chapters 17F.050](#) and [17G.061 SMC](#).

#### F. Final Short Plat Review Procedure

- 1. The subdivider shall submit to the director for review the following:

- a. A final short plat, prepared by a registered land surveyor licensed in the state of Washington, consistent with the approved preliminary short plat.
  - b. A title report less than thirty days old confirming that the title of the lands as described and shown on said plat is in the name of the owners signing the certificate or instrument of dedication.
  - c. Covenants, conditions and restrictions, if applicable; and
  - d. Fees pursuant to [chapter 8.02 SMC](#).
2. Within thirty days, unless the applicant has consented to a longer period of time, of receipt of a proposed final short plat, the director shall review the plat for conformance with all conditions of the preliminary short plat approval, the requirements of this chapter and that arrangements have been made to insure the construction of required improvements. If all such conditions are met, the director shall approve the final short plat and authorize the recording of the plat. If all conditions are not met, the director shall provide the applicant in writing a statement of the necessary changes to bring the final short plat into conformance with the conditions.
  - a. If the final short plat is required to be resubmitted, the subdivider is required to provide the following:
    - b. A cover letter addressing the corrections, additions or modifications required.
    - c. Title report no older than thirty days from issuance of a title company conforming that the title of the lands as described and shown on said plat is in the name of the owners signing the certificate or instrument of dedication; and
    - d. The required number of copies of the corrected final short plat map.
3. If the final short plat is approved, the surveyor causes the plat to be signed by the Spokane county treasurer and file of record with the Spokane county auditor. The surveyor is required to file the



appropriate number of mylar and bond copies of the recorded short plat with the director.

#### G. Final Short Plat Map Requirements

The subdivider shall submit to the director a final short plat in the same form and with the same content as the preliminary short plat, as provided in subsections (B)(1) and (2) of this section, with the following exceptions or additional requirements:

1. A final short plat shall contain all the information required of the preliminary plat, except the following:

- a. Show existing buildings.
- b. Show existing utility lines and underground structures.
- c. Show the topographical elevations; or
- d. Contain the names and addresses of adjoining landowners.

2. The final short plat shall include the following:

a. Surveyor's certificate, stamp, date and signature, as follows:

The following land surveyor's certificate to be shown on each sheet of the plat: "I, \_\_\_\_\_ registered land surveyor, hereby certify the plat of \_\_\_\_\_, as shown hereon, is based upon actual field survey of the land described and that all angles, distances, and courses are correctly shown and that all non fronting lot corners are set as shown on the plat. Monuments and fronting lot corners shall be set upon completion of the utility and street improvements.

Signed \_\_\_\_\_(Seal)"

b. A certification by the city treasurer, as applicable:

- i. "I hereby certify that the land described by this plat, as of the date of this certification, is not subject to any local improvement assessments. Examined and approved, this \_\_\_\_\_ day of \_\_\_\_\_, 20\_\_.

---

City of Spokane Treasurer”

- ii. “I hereby certify that the land described by this plat, as of the date of this certificate, is not subject to any delinquent local improvement assessment. Future installments, if any, shall remain due and payable and it shall be the responsibility of the owners to initiate the segregation of the LID assessment. Examined and approved, this \_\_\_\_ day of \_\_\_\_\_, 20\_\_.

---

City of Spokane Treasurer”

- iii. “A preliminary local improvement assessment exists against this property. It shall be the responsibility of the owner’s to initiate the segregation of the LID assessment. After this assessment is finalized, it shall be due and payable. Examined and approved this \_\_\_\_ day of \_\_\_\_\_, 20\_\_.

---

City of Spokane Treasurer”

- c. The certification by the planning director, as follows:

“This plat has been reviewed on this \_\_\_\_ day of \_\_\_\_\_, 20\_\_ and is found to be in full compliance with all the conditions of approval stipulated in the Hearing Examiner’s/Planning Director’s approval of the preliminary plat # - -PP/SP.

---

City of Spokane Planning Director”

- d. The certification by the city engineer, as follows:

“Approved as to compliance with the survey data, the design of public works and provisions made for constructing the

improvements and permanent control monuments this \_\_\_\_\_  
day of \_\_\_\_\_, 20\_\_.

\_\_\_\_\_

City of Spokane Engineer”

e. The certification by the Spokane county treasurer, as follows:

“I hereby certify that the land described in this plat, as of the date of this certification, is not subject to any outstanding fees or assessments. Examined and approved \_\_\_\_\_ day of \_\_\_\_\_, 20\_\_.

\_\_\_\_\_

Spokane County Treasurer”

f. The certification by the Spokane county auditor on each page of the final short plat including the time, date, book and page number of the recording of the final mylar.

g. Signature of every owner certifying that:

- i. the plat is made with the free consent and in accordance with the desires of the owners of the land;
- ii. the plat is made with the free consent and in accordance with the desires of the owners of the land;
- iii. the owners are the owners of the property and the only parties having interest in the land and is not encumbered by any delinquent taxes or assessments;
- iv. the owners adopt the plan of lots, blocks and streets shown;
- v. owner dedicates to the City and the City’s permittees the easements shown for utilities and cable television purposes;
- vi. owner dedicates to the City the streets, alleys and other public places, including slope and construction easements

and waives all claims for damages against any governmental authority including, without limitation, the City which may be occasioned to the adjacent land by the establishment, construction, drainage and maintenance of any public way so dedicated; and

vii. owner conveys to the City as general City property the buffer strips adjoining unplatted property.

h. The drawing shall:

- i. be a legibly drawn, printed or reproduced permanent map;
- ii. if more than one sheet is required, each sheet shall show sheet numbers for the total sheets;
- iii. have margins that comply with the standards of the Spokane county auditor;
- iv. show in dashed lines the existing plat being replatted, if applicable;
- v. show monuments in accordance with [SMC 17G.080.020\(H\)\(1\)](#);
- vi. include any other information required by the conditions of approval; and
- vii. include any special statements of approval required from governmental agencies, including those pertaining to flood hazard areas, shorelines, critical areas and connections to adjacent state highways.

H. Filing.

Once the final plat has been reviewed, approved and signed by the applicable departments, the applicant shall file the final short plat with the county auditor within ten days of approval. No permits shall be issued for a proposed lot until the required conformed copies of the short plat have been submitted to the planning services department.

I. Redivision.

No land within the boundaries of a short subdivision may be further divided in any manner which will create additional lots within a period of five years except by subdivision in accordance with [SMC 17G.080.050](#).

Date Passed: Monday, November 20, 2023

Effective Date: Monday, January 1, 2024

ORD C36459 Section 42

## Title 17G Administration and Procedures

### Chapter 17G.080 Subdivisions

#### Section 17G.080.060 Binding Site Plan

##### A. Purpose.

The purpose of this section is to allow for the more flexible creation of lots within an overall development site plan.

##### B. Predevelopment Meeting.

A predevelopment meeting is recommended (~~required~~) if the proposal is located in the central business district, unless waived by the director, and is recommended for all other proposals prior to submittal of the application. The purpose of a predevelopment meeting is to acquaint the applicant with the applicable provisions of this chapter, minimum submission requirements and other plans or regulations, which may impact the proposal.

##### C. Preliminary Binding Site Plan Application and Map Requirements.

1. A binding site plan may be used for divisions of land in all zones. Applications for approval of a preliminary binding site plan shall be filed with the director. All applications shall be submitted on forms provided for such purpose by the department. The director may waive specific submittal requirements determined to be unnecessary for review of the application. The application shall be same in form and contents as a short plat as provided in SMC 17G.080.040(B)(1).
2. Contents of Preliminary Binding Site Plan.

The preliminary binding site plan shall be prepared by a land surveyor and shall be the same in form and content as a short plat as provided in SMC 17G.080.040(B)(2) with the following additions:

- a. Proposed building footprints;
- b. Proposed street accesses;

- c. Proposed parking and internal vehicle circulation;
- d. Proposed pedestrian pathways;
- e. Proposed landscaped areas; and
- f. Proposed stormwater facilities.

#### D. Public Notice

All public notice of the application shall be given in accordance with the procedures set forth in [chapter 17C.061 SMC](#) for a Type II application.

#### E. Departmental Review of Preliminary Binding Site Plan

The application shall be reviewed in accordance with the procedures set forth in [chapter 17G.061 SMC](#) for a Type II application.

#### F. Preliminary Binding Site Plan Decision Criteria

Prior to approval of the application, the director shall find the application to be in the public use and interest, conform to applicable land use controls and the comprehensive plan of the City, and the decision criteria set forth in [SMC 17G.080.025](#). The director has the authority to approve or disapprove a proposed preliminary binding site plan under the provisions of this chapter, subject to appeal as provided in [chapter 17G.061 SMC](#).

#### G. Final Binding Site Plan Review Procedure

The final binding site plan procedures shall be the same in form as the short plat review procedure as provided in [SMC 17G.080.040\(G\)](#).

#### H. Final Binding Site Plan Requirements.

The subdivider shall submit to the director a final binding site plan in the same form and with the same content as the preliminary binding site plan, with the following exceptions or additional requirements:

1. A final binding site plan shall contain all the information required of the preliminary plan, except the following:
  - a. Show existing buildings.

- b. Show existing utility lines and underground structures.
  - c. Show the topographical elevations; or
  - d. Contain the names and addresses of adjoining landowners.
2. The final binding site plan shall include the signatory statements as provided in [SMC 17G.080.040\(G\)\(2\)](#).

#### I. Filing

Once the final binding site plan has been reviewed, approved and signed by the applicable departments, the applicant shall file the final binding site plan with the county auditor within ten days of final approval. No permits shall be issued for a proposed lot until the required conformed copies of the binding site plan have been submitted to the department.

#### J. Creation of Additional Lots in Final Binding Site Plan

A survey may be filed following the recording of a final binding site plan to create additional lots within the boundaries of the final binding site plan, consistent with the preliminary binding site plan approval, conditions and expiration provisions ([SMC 17G.080.020\(C\)](#)). The survey shall be reviewed and approved by the director pursuant to subsections (F) and (G) of this section. In addition, the survey shall conform to the following:

1. Title shall state: "Amendment to BSP- \_\_\_\_ - \_\_\_\_."
2. The binding site plan file number shall be referenced.
3. A distinct wide boundary line shall delineate the boundary of the lot(s) being created. The boundary of the binding site plan shall be indicated and any lot(s) that have been created by filing of the final binding site plan and/or record of survey.
4. Each lot shall be numbered consecutively, and the size of each lot shall be indicated on the survey; and
5. A revision block listing all previously recorded surveys and the date of recording.

Date Passed: Monday, November 20, 2023



Effective Date: Monday, January 1, 2024

ORD C36459 Section 44

## EXHIBIT C – RELATED COMPREHENSIVE PLAN GOALS AND POLICIES

### **Goal ED 7 REGULATORY ENVIRONMENT AND TAX STRUCTURE**

Goal: Create a regulatory environment and tax structure that encourage investment, nurture economic activity, and promote a good business climate.

#### **Policy ED 7.6 Development Standards and Permitting Process**

*Periodically evaluate and improve the City of Spokane's development standards and permitting process to ensure that they are equitable, cost-effective, timely, and meet community needs and goals*

## EXHIBIT D – FINDINGS AND CONCLUSIONS



**Agenda Sheet for City Council:**

**Committee:** Finance & Administration **Date:** 09/23/2024

**Committee Agenda type:** Consent

**Date Rec'd** 9/6/2024

**Clerk's File #** FIN 2024-0001

**Cross Ref #**

**Project #**

**Council Meeting Date:** 10/28/2024

<b>Submitting Dept</b>	FINANCE, TREASURY & ADMIN	<b>Bid #</b>	
------------------------	---------------------------	--------------	--

<b>Contact Name/Phone</b>	JESSICA 954-9217	<b>Requisition #</b>	
---------------------------	------------------	----------------------	--

<b>Contact E-Mail</b>	JSTRATTON@SPOKANECITY.ORG		
-----------------------	---------------------------	--	--

<b>Agenda Item Type</b>	Hearings		
-------------------------	----------	--	--

<b>Council Sponsor(s)</b>	MCATHCART BWILKERSON ZZAPPONE		
---------------------------	-------------------------------	--	--

<b>Agenda Item Name</b>	0410 - SET CIP HEARING		
-------------------------	------------------------	--	--

**Agenda Wording**

Set hearing for November 4, 2024 for the Citywide Capital Improvement Program 2025-2030. The first reading of the CIP ordinance will be held October 28, 2024, at which time public testimony will also be taken.

**Summary (Background)**

In accordance with the State Growth Management Act and the City of Spokane's Spokane Municipal Code Chapter 07.17, the City must adopt and annually update a Citywide Six-Year Capital Improvement Program. The Program must be updated annually as part of the budget process. With the approval of the 2025-2026 biennium budget, the first and second year of the Capital Improvement Program reflects the budget.

Lease? NO Grant related? NO Public Works? NO

**Fiscal Impact**

Approved in Current Year Budget? N/A

Total Cost \$

Current Year Cost \$

Subsequent Year(s) Cost \$

**Narrative**

<b>Amount</b>	<b>Budget Account</b>
Select \$	#
Select \$	#
Select \$	#
Select \$	#
\$	#
\$	#



## Committee Agenda Sheet

### Finance & Administration Committee

<b>Committee Date</b>	September 23, 2024
<b>Submitting Department</b>	Finance
<b>Contact Name</b>	Jessica Stratton
<b>Contact Email &amp; Phone</b>	<a href="mailto:jstratton@spokanecity.org">jstratton@spokanecity.org</a> 509-954-9217
<b>Council Sponsor(s)</b>	Cathcart, Wilkerson, Zappone
<b>Select Agenda Item Type</b>	<input checked="" type="checkbox"/> Consent <input type="checkbox"/> Discussion    Time Requested: min
<b>Agenda Item Name</b>	Set Capital Improvement Program (CIP) Hearing
<b>Proposed Council Action</b>	<input checked="" type="checkbox"/> Approval to proceed to Legislative Agenda <input type="checkbox"/> Information Only
<b>Summary (Background)</b>	<p>Set hearing for November 4, 2024 for the Citywide Capital Improvement Program 2025-2030. The first reading of the CIP ordinance will be held October 28, 2024, at which time public testimony will also be taken.</p> <p>In accordance with the State Growth Management Act and the City of Spokane's Spokane Municipal Code Chapter 07.17, the City must adopt and annually update a Citywide Six-Year Capital Improvement Program. The Program must be updated annually as part of the budget process. With the approval of the 2025-2026 biennium budget, the first and second year of the Capital Improvement Program reflects the budget.</p>
<b>Fiscal Impact</b>	<p><b>Approved in current year budget?</b>    <input type="checkbox"/> Yes    <input type="checkbox"/> No    <input checked="" type="checkbox"/> N/A</p> <p>Total Cost: <a href="#">Click or tap here to enter text.</a></p> <p>Current year cost:</p> <p>Subsequent year(s) cost:</p> <p><b>Narrative:</b> Please provide financial due diligence review, as applicable, such as number and type of positions, grant match requirements, summary type details (personnel, maintenance and supplies, capital, revenue), impact on rates, fees, or future shared revenue</p> <p><b>Funding Source</b>    <input type="checkbox"/> One-time    <input type="checkbox"/> Recurring    <input type="checkbox"/> N/A</p> <p>Specify funding source: <a href="#">Select Funding Source*</a></p> <p>Is this funding source sustainable for future years, months, etc? <a href="#">Click or tap here to enter text.</a></p> <p><b>Expense Occurrence</b>    <input type="checkbox"/> One-time    <input type="checkbox"/> Recurring    <input type="checkbox"/> N/A</p> <p>Other budget impacts: (revenue generating, match requirements, etc.)</p>
<b>Operations Impacts (If N/A, please give a brief description as to why)</b>	<ul style="list-style-type: none"> <li>• What impacts would the proposal have on historically excluded communities? – N/A</li> <li>• How will data be collected, analyzed, and reported concerning the effect of the program/policy by racial, ethnic, gender identity, national origin, income level, disability, sexual orientation, or other existing disparities? – N/A</li> <li>• How will data be collected regarding the effectiveness of this program, policy, or product to ensure it is the right solution? – N/A</li> </ul>

- Describe how this proposal aligns with current City Policies, including the Comprehensive Plan, Sustainability Action Plan, Capital Improvement Program, Neighborhood Master Plans, Council Resolutions, and others? – N/A

**Council Subcommittee Review**

- Please provide a summary of council subcommittee review. If not reviewed by a council subcommittee, please explain why not. – N/A



**Agenda Sheet for City Council:**

**Committee:** Finance & Administration **Date:** 09/23/2024

**Committee Agenda type:** Consent

**Date Rec'd**

9/9/2024

**Clerk's File #**

ORD C36598

**Cross Ref #**

**Project #**

**Council Meeting Date:** 10/28/2024

**Submitting Dept**

FINANCE, TREASURY & ADMIN

**Bid #**

**Contact Name/Phone**

JESSICA 625-6585

**Requisition #**

**Contact E-Mail**

JSTRATTON@SPOKANECITY.ORG

**Agenda Item Type**

First Reading Ordinance

**Council Sponsor(s)**

MCATHCART BWILKERSON ZZAPPONE

**Agenda Item Name**

0410 - 2025 CAPITAL IMPROVEMENT PROGRAM (CIP) ORDINANCE

**Agenda Wording**

An update on the CIP will be delivered to the City Council on October 24, 2024. A Plan Commission workshop will be held on September 25, 2024 and the Plan Commission hearing will be held on October 9, 2024.

**Summary (Background)**

In accordance with the State Growth Management Act and the City of Spokane's Spokane Municipal Code Chapter 07.17, the City must annually update and adopt a Citywide Six Year Capital Improvement Program. The Program must be updated annually as part of the budget process. The first two years of the CIP are incorporated into the 2025-2026 Biennium Budget.

Lease? NO Grant related? NO Public Works? NO

**Fiscal Impact**

Approved in Current Year Budget? N/A

Total Cost \$

Current Year Cost \$

Subsequent Year(s) Cost \$

**Narrative**

**Amount**

**Budget Account**

Select	\$	#
Select	\$	#
Select	\$	#
Select	\$	#
	\$	#
	\$	#





## Committee Agenda Sheet

### Finance & Administration Committee

<b>Committee Date</b>	September 23, 2024
<b>Submitting Department</b>	Finance
<b>Contact Name</b>	Jessica Stratton
<b>Contact Email &amp; Phone</b>	<a href="mailto:jstratton@spokanecity.org">jstratton@spokanecity.org</a> 509-954-9217
<b>Council Sponsor(s)</b>	Cathcart, Wilkerson, Zappone
<b>Select Agenda Item Type</b>	<input checked="" type="checkbox"/> Consent <input type="checkbox"/> Discussion    Time Requested: min
<b>Agenda Item Name</b>	2025 Capital Improvement Program (CIP) Ordinance
<b>Proposed Council Action</b>	<input checked="" type="checkbox"/> Approval to proceed to Legislative Agenda <input type="checkbox"/> Information Only
<b>Summary (Background)</b>	<p><u>Background</u></p> <p>In accordance with the State Growth Management Act and the City of Spokane’s Spokane Municipal Code Chapter 07.17, the City must annually update and adopt a Citywide Six Year Capital Improvement Program. The Program must be updated annually as part of the budget process. The first two years of the CIP are incorporated into the 2025-2026 Biennium Budget.</p> <p>An update on the CIP will be delivered to the City Council on October 24, 2024. A Plan Commission workshop will be held on September 25, 2024 and the Plan Commission hearing will be held on October 9, 2024.</p> <p>The first reading of the CIP ordinance will be on October 28, 2024 with the final reading and adoption on November 4, 2024.</p>
<b>Fiscal Impact</b>	<p><b>Approved in current year budget?</b>    <input type="checkbox"/> Yes    <input type="checkbox"/> No    <input checked="" type="checkbox"/> N/A</p> <p>Total Cost: <a href="#">Click or tap here to enter text.</a></p> <p>Current year cost:</p> <p>Subsequent year(s) cost:</p> <p><b>Narrative:</b> Please provide financial due diligence review, as applicable, such as number and type of positions, grant match requirements, summary type details (personnel, maintenance and supplies, capital, revenue), impact on rates, fees, or future shared revenue</p> <p><b>Funding Source</b>    <input type="checkbox"/> One-time    <input type="checkbox"/> Recurring    <input type="checkbox"/> N/A</p> <p>Specify funding source: Select Funding Source*</p> <p>Is this funding source sustainable for future years, months, etc? <a href="#">Click or tap here to enter text.</a></p> <p><b>Expense Occurrence</b>    <input type="checkbox"/> One-time    <input type="checkbox"/> Recurring    <input type="checkbox"/> N/A</p> <p>Other budget impacts: (revenue generating, match requirements, etc.)</p>
<b>Operations Impacts (If N/A, please give a brief description as to why)</b>	<ul style="list-style-type: none"> <li>• What impacts would the proposal have on historically excluded communities? – N/A</li> <li>• How will data be collected, analyzed, and reported concerning the effect of the program/policy by racial, ethnic, gender identity, national origin, income level, disability, sexual orientation, or other existing disparities? – N/A</li> </ul>

- How will data be collected regarding the effectiveness of this program, policy, or product to ensure it is the right solution? – N/A
- Describe how this proposal aligns with current City Policies, including the Comprehensive Plan, Sustainability Action Plan, Capital Improvement Program, Neighborhood Master Plans, Council Resolutions, and others? – N/A

**Council Subcommittee Review**

- Please provide a summary of council subcommittee review. If not reviewed by a council subcommittee, please explain why not. – N/A

## ORDINANCE NO. C36598

AN ORDINANCE OF THE CITY OF SPOKANE, WASHINGTON, ADOPTING A SIX-YEAR CITYWIDE CAPITAL IMPROVEMENT PROGRAM FOR THE YEARS 2025 THROUGH 2030. AND AMENDING THE CITYWIDE CAPITAL IMPROVEMENT PROGRAM (CIP) AS REFERENCED IN APPENDIX C OF THE CITY OF SPOKANE COMPREHENSIVE PLAN.

WHEREAS, in accordance with the Growth Management Act (“GMA”), the City of Spokane previously adopted a Comprehensive Plan that includes a Capital Facilities Plan (“CFP”) that includes an inventory, analysis, and a six-year financing plan for needed capital facilities otherwise referred to as the Six-Year Capital Improvement Program; and

WHEREAS, the City formed a Capital Improvement Program Team which has assembled proposed amendments to the CIP, which amendments consist of an updated six-year plan (years 2025 through 2030) identifying the proposed locations and capacities of expanded or new capital facilities and a plan to finance such capital facilities within projected funding capacities (the “Six-Year Citywide Capital Improvement Program” or “CIP”); and

WHEREAS, the City previously adopted the Six-Year Street Program (RCW 35.77.010) on June 24, 2024 by Council Resolution 2024-0060, and that program is incorporated into the CIP; and

WHEREAS, GMA provides that proposed amendments to a comprehensive plan may be considered by the governing body of a city no more frequently than once per year, but further provides that amendments to the capital facilities element of a comprehensive plan may be considered outside of this annual process where the amendment is considered concurrently with the adoption or amendment of a city budget; and

WHEREAS, on September 24, 2024, the City’s responsible official issued a Determination of Non-Significance for the CIP; and

WHEREAS, the Spokane City Plan Commission conducted a public workshop regarding the CIP on September 25, 2024; and

WHEREAS, after providing appropriate public notices, on October 9, 2024, the Spokane City Plan Commission, conducted a public hearing to take testimony on the CIP, and at the close of the hearing, and after considering public input, the SEPA determination, and required decision criteria, found that the CIP is consistent with the Comprehensive Plan and voted unanimously to recommend that the City Council approve the CIP; and

Now, Therefore,

The City of Spokane does ordain:

Section 1. Amendment. The City of Spokane Comprehensive Plan and its capital facilities element are hereby amended to reflect a six-year plan for capital improvement projects (2025-2030), as set forth in the attached Citywide Capital Improvement Program (2025-2030).

A. Any vehicle procurement must comply with Spokane Municipal Code 07.06.175A regarding the procurement of clean fuel vehicles.

Section 2. Authorization to Seek Funding. City staff are authorized to apply for state and federal grants and low-interest loans in support of the projects identified in the Citywide Capital Improvement Program (2025-2030).

Section 3. Effective Date. This ordinance shall take effect and be in force on \_\_\_\_\_.

PASSED BY THE CITY COUNCIL ON \_\_\_\_\_.

\_\_\_\_\_

Council President

Attest:

Approved as to Form:

\_\_\_\_\_

City Clerk

\_\_\_\_\_

Assistant City Attorney

\_\_\_\_\_

Mayor

\_\_\_\_\_

Date



2023/2024 Comprehensive Plan Amendments

## **PLAN COMMISSION FINDINGS OF FACT, CONCLUSIONS, AND RECOMMENDATIONS ON COMPREHENSIVE PLAN AMENDMENT FILE Z24-306COMP**

**A Recommendation of the Spokane Plan Commission to the City Council to APPROVE the 2025-2030 Capital Improvement Program as an appendix to the Comprehensive Plan.**

### **FINDINGS OF FACT:**

- A. The City of Spokane adopted a Comprehensive Plan in May of 2001 that complies with the requirements of the Growth Management Act (GMA).
- B. Proposal file Z24-306COMP (the “Proposal”) was submitted in a timely manner for review in advance of the City’s budget approval process, as required.
- C. The Proposal seeks to append the 2025-2030 Capital Improvement Program (the “CIP”) to the Comprehensive Plan as a necessary step towards the eventual adoption of the 2025/2026 City of Spokane Budget.
- D. The CIP identifies capital project activity which has implications on the growth of the community.
- E. On September 4, 2024, staff requested comments from agencies, departments, and neighborhood councils regarding the proposal. One comment was received from the Department of Fish and Wildlife with advisory requests for the Comprehensive Plan in general.
- F. A Notice of Application was published on September 4, 2024 in the Spokesman Review and was emailed to the City’s Plan Commission distribution list and to every neighborhood council contact in the City, asking for public comments on the proposal. No comments were received.
- G. On September 4, 2024, the Washington State Department of Commerce and appropriate state agencies were given the required 60-day notice of intent to adopt before adoption of any proposed changes to the Comprehensive Plan.
- H. On September 25, 2024, the Spokane City Plan Commission held a workshop to study the Proposal.
- I. On September 24, 2024, a State Environmental Policy Act (SEPA) Checklist and Determination of Non-Significance were issued for the Proposal. The deadline to appeal the SEPA determination was October 8, 2024. No comments on the SEPA determination were received.
- J. On October 2, 2024, staff published a report addressing SEPA and providing staff’s analysis of the merits of the Proposal, copies of which were circulated as prescribed by SMC 17G.020.060B.8. Staff’s analysis of the Proposal recommended approval of the Proposal.

- K. On October 9, 2024, the Plan Commission held a public hearing on the Proposal, including the taking of verbal testimony, and closed the public record on that date. No members of the public testified.
- L. On October 9, 2024, the Plan Commission conducted its deliberations on this application and voted to recommend the City Council **approve** this application as proposed.
- M. As a result of the City's efforts, pursuant to the requirements of SMC 17G.020.070, the public has had extensive opportunities to participate throughout the process and persons desiring to comment were given an opportunity to do so.
- N. Except as may be otherwise indicated herein, the Plan Commission adopts the findings and analysis set forth in the Staff Report prepared for the Proposal (the "Staff Report").
- O. The Plan Commission finds that the proposal meets the intent and requirements of the Comprehensive Plan.
- P. The Plan Commission finds that the proposal meets the decision criteria established by SMC 17G.020.030, as described in the Staff Report.

#### **CONCLUSIONS:**

Based upon the proposal materials, staff analysis (which is hereby incorporated into these findings, conclusions, and recommendation), SEPA review, agency and public comments received, and public testimony presented regarding application File No. Z24-306COMP, the Plan Commission makes the following conclusions with respect to the review criteria outlined in SMC 17G.020.030:

1. Interested agencies and the public have had extensive opportunities to participate throughout the process and persons desiring to comment have been given that opportunity to comment.
2. The Proposal is consistent with the goals and purposes of GMA.
3. Any potential infrastructure implications associated with the Application will either be mitigated through projects reflected in the City's relevant six-year capital improvement plan or through enforcement of the City's development regulations at time of development.
4. As outlined in above in the Findings of Fact, the Proposal is internally consistent as it pertains to the Comprehensive Plan, as described in SMC 17G.020.030.E and as required by RCW 36.70A and RCW 35.77.010.
5. The Proposal is consistent with the Countywide Planning Policies for Spokane County, the comprehensive plans of neighboring jurisdictions, applicable capital facilities plans, the regional transportation plan, and official population growth forecasts.
6. The Proposal has been considered in order to evaluate the cumulative effect of all the proposals.
7. SEPA review was completed for the Proposal.
8. The Proposal will not adversely affect the City's ability to provide the full range of urban public facilities and services citywide at the planned level of service, or consume public resources otherwise needed to support comprehensive plan implementation strategies.

9. The Proposal proposes that a document be appended to the Comprehensive Plan.

**RECOMMENDATIONS:**

In the matter of Z24-306COMP, a request by the City of Spokane Budget Office to append the 2025-2030 Capital Improvement Program to the Comprehensive Plan and forward the document on for the consideration of City Council during the annual budget process, by a vote of **9 to 0**, the Spokane Plan Commission recommends City Council **APPROVE** the proposal and authorizes the President to prepare and sign on the Commission's behalf a written decision setting forth the Commission's findings, conclusions, and recommendation on the application.

*Greg Francis*

Greg Francis (Oct 22, 2024 15:07 PDT)

---

**Greg Francis, President**

Spokane Plan Commission

Date: Oct 22, 2024









# PC Findings and Conclusions - 2025-2030 CIP

Final Audit Report

2024-10-22

Created:	2024-10-22
By:	Angela McCall (amccall@spokanecity.org)
Status:	Signed
Transaction ID:	CBJCHBCAABAACy5QrCzQCvEJkYeKZIQBlS-2ybfvqqHJ

## "PC Findings and Conclusions - 2025-2030 CIP" History

-  Document created by Angela McCall (amccall@spokanecity.org)  
2024-10-22 - 5:20:53 PM GMT
-  Document emailed to gfrancis@spokanecity.org for signature  
2024-10-22 - 5:21:11 PM GMT
-  Email viewed by gfrancis@spokanecity.org  
2024-10-22 - 10:06:52 PM GMT
-  Signer gfrancis@spokanecity.org entered name at signing as Greg Francis  
2024-10-22 - 10:07:26 PM GMT
-  Document e-signed by Greg Francis (gfrancis@spokanecity.org)  
Signature Date: 2024-10-22 - 10:07:28 PM GMT - Time Source: server
-  Agreement completed.  
2024-10-22 - 10:07:28 PM GMT

**The 2025-2030 DRAFT Citywide Capital Improvement Plan (CIP) can be found on the City of Spokane's Budget Webpage:**

**<https://my.spokanecity.org/budget/>**

**Direct link to document:**

**<https://static.spokanecity.org/documents/budget/2025/draft-2025-2030-citywide-capital-improvement-program-2024-10-16.pdf>**

**Agenda Sheet for City Council:****Committee:** Finance & Administration **Date:** 09/23/2024**Committee Agenda type:** Consent**Date Rec'd**

9/4/2024

**Clerk's File #**

FIN 2024-0001

**Cross Ref #****Project #****Council Meeting Date:** 10/28/2024**Submitting Dept**

FINANCE, TREASURY &amp; ADMIN

**Bid #****Contact Name/Phone**

JESSICA 954-9217

**Requisition #****Contact E-Mail**

JSTRATTON@SPOKANECITY.ORG

**Agenda Item Type**

Hearings

**Council Sponsor(s)**

BWILKERSON ZZAPPONE

**Agenda Item Name**

0410 - SET REVENUE HEARING

**Agenda Wording**

Setting public hearing on possible revenue sources for the 2025 Budget on November 4, 2024.

**Summary (Background)**

A city such as Spokane that collects a regular property tax levy must hold a public hearing on possible revenue sources for the 2025 current expense budget, including consideration of possible increases in property tax revenues (RCW 84.55.120). This hearing must be held before the meeting at which the City Council considers levy adoption. The property tax ordinance will be on the Council's November 4, 2024 agenda.

Lease? NO

Grant related? NO

Public Works? NO

**Fiscal Impact**

Approved in Current Year Budget? N/A

Total Cost

\$

Current Year Cost

\$

Subsequent Year(s) Cost

\$

**Narrative****Amount****Budget Account**

Select

\$

#

Select

\$

#

Select

\$

#

Select

\$

#

\$

#

\$

#



## Committee Agenda Sheet

### Finance & Administration Committee

<b>Committee Date</b>	September 23, 2024
<b>Submitting Department</b>	Finance
<b>Contact Name</b>	Jessica Stratton
<b>Contact Email &amp; Phone</b>	<a href="mailto:jstratton@spokanecity.org">jstratton@spokanecity.org</a> 509-954-9217
<b>Council Sponsor(s)</b>	Wilkerson, Zappone
<b>Select Agenda Item Type</b>	<input checked="" type="checkbox"/> Consent <input type="checkbox"/> Discussion    Time Requested: min
<b>Agenda Item Name</b>	Set Revenue Hearing
<b>Proposed Council Action</b>	<input checked="" type="checkbox"/> Approval to proceed to Legislative Agenda <input type="checkbox"/> Information Only
<b>Summary (Background)</b>	<p>Setting public hearing on possible revenue sources for the 2025 Budget on October 28, 2024.</p> <p>*use the Fiscal Impact box below for relevant financial information</p> <p>A city such as Spokane that collects a regular property tax levy must hold a public hearing on possible revenue sources for the 2025 current expense budget, including consideration of possible increases in property tax revenues (RCW 84.55.120). This hearing must be held before the meeting at which the City Council considers levy adoption. The property tax ordinance will be on the Council's November 4, 2024 agenda.</p>
<p><b>Fiscal Impact</b></p> <p><b>Approved in current year budget?</b>    <input type="checkbox"/> Yes    <input type="checkbox"/> No    <input checked="" type="checkbox"/> N/A</p> <p>Total Cost: <a href="#">Click or tap here to enter text.</a></p> <p>    Current year cost:</p> <p>    Subsequent year(s) cost:</p> <p><b>Narrative:</b> Please provide financial due diligence review, as applicable, such as number and type of positions, grant match requirements, summary type details (personnel, maintenance and supplies, capital, revenue), impact on rates, fees, or future shared revenue</p> <p><b>Funding Source</b>    <input type="checkbox"/> One-time    <input type="checkbox"/> Recurring    <input type="checkbox"/> N/A</p> <p>Specify funding source: <a href="#">Select Funding Source*</a></p> <p>Is this funding source sustainable for future years, months, etc? <a href="#">Click or tap here to enter text.</a></p> <p><b>Expense Occurrence</b>    <input type="checkbox"/> One-time    <input type="checkbox"/> Recurring    <input type="checkbox"/> N/A</p> <p>Other budget impacts: (revenue generating, match requirements, etc.)</p>	
<p><b>Operations Impacts (If N/A, please give a brief description as to why)</b></p> <ul style="list-style-type: none"> <li>• What impacts would the proposal have on historically excluded communities? – N/A</li> <li>• How will data be collected, analyzed, and reported concerning the effect of the program/policy by racial, ethnic, gender identity, national origin, income level, disability, sexual orientation, or other existing disparities? – N/A</li> <li>• How will data be collected regarding the effectiveness of this program, policy, or product to ensure it is the right solution? – N/A</li> </ul>	

- Describe how this proposal aligns with current City Policies, including the Comprehensive Plan, Sustainability Action Plan, Capital Improvement Program, Neighborhood Master Plans, Council Resolutions, and others? – N/A

**Council Subcommittee Review**

- Please provide a summary of council subcommittee review. If not reviewed by a council subcommittee, please explain why not. – N/A

**Agenda Sheet for City Council:****Committee:** Finance & Administration **Date:** 09/23/2024**Committee Agenda type:** Consent**Date Rec'd**

10/22/2024

**Clerk's File #**

ORD C36599

**Cross Ref #****Project #****Council Meeting Date:** 11/04/2024**Submitting Dept**

FINANCE, TREASURY &amp; ADMIN

**Bid #****Contact Name/Phone**

JESSICA 625-6585

**Requisition #****Contact E-Mail**

JSTRATTON@SPOKANECITY.ORG

**Agenda Item Type**

Final Reading Ordinance

**Council Sponsor(s)**

BWILKERSON ZZAPPONE

**Agenda Item Name**

0410 - 2025 PROPERTY TAX ORDINANCE

**Agenda Wording**

Adoption of the 2025 Property Tax Ordinance.

**Summary (Background)**

Each year, per RCW 84.52.070, the City Council must pass the annual property tax levy and transmit to the County Assessor and the Board of County Commissioners, the amount of property taxes levied on property in the City. The revenue hearing will be on October 28, 2024 with the ordinance on November 4, 2024.

Lease? NO

Grant related? NO

Public Works? NO

**Fiscal Impact**

Approved in Current Year Budget? N/A

Total Cost \$

Current Year Cost \$

Subsequent Year(s) Cost \$

**Narrative****Amount****Budget Account**

Select \$ #

Select \$ #

Select \$ #

Select \$ #

\$ #

\$ #





## Committee Agenda Sheet

### Finance & Administration Committee

<b>Committee Date</b>	September 23, 2024
<b>Submitting Department</b>	Finance
<b>Contact Name</b>	Jessica Stratton
<b>Contact Email &amp; Phone</b>	<a href="mailto:jstratton@spokanecity.org">jstratton@spokanecity.org</a> 509-954-9217
<b>Council Sponsor(s)</b>	Wilkerson, Zappone
<b>Select Agenda Item Type</b>	<input checked="" type="checkbox"/> Consent <input type="checkbox"/> Discussion    Time Requested: min
<b>Agenda Item Name</b>	2025 Property Tax Ordinance
<b>Proposed Council Action</b>	<input checked="" type="checkbox"/> Approval to proceed to Legislative Agenda <input type="checkbox"/> Information Only
<b>Summary (Background)</b>	<p><u>Background</u></p> <p>Each year, per RCW 84.52.070, the City Council must pass the annual property tax levy and transmit to the County Assessor and the Board of County Commissioners, the amount of property taxes levied on property in the City.</p> <p>The revenue hearing will be on October 28, 2024 with the ordinance on November 4, 2024.</p>
<b>Fiscal Impact</b>	<p><b>Approved in current year budget?</b>    <input type="checkbox"/> Yes    <input type="checkbox"/> No    <input checked="" type="checkbox"/> N/A</p> <p>Total Cost: <a href="#">Click or tap here to enter text.</a></p> <p>Current year cost:</p> <p>Subsequent year(s) cost:</p> <p><b>Narrative:</b> Please provide financial due diligence review, as applicable, such as number and type of positions, grant match requirements, summary type details (personnel, maintenance and supplies, capital, revenue), impact on rates, fees, or future shared revenue</p> <p><b>Funding Source</b>    <input type="checkbox"/> One-time    <input type="checkbox"/> Recurring    <input type="checkbox"/> N/A</p> <p>Specify funding source: <a href="#">Select Funding Source*</a></p> <p>Is this funding source sustainable for future years, months, etc? <a href="#">Click or tap here to enter text.</a></p> <p><b>Expense Occurrence</b>    <input type="checkbox"/> One-time    <input type="checkbox"/> Recurring    <input type="checkbox"/> N/A</p> <p>Other budget impacts: (revenue generating, match requirements, etc.)</p>
<b>Operations Impacts (If N/A, please give a brief description as to why)</b>	<ul style="list-style-type: none"> <li>• What impacts would the proposal have on historically excluded communities? – N/A</li> <li>• How will data be collected, analyzed, and reported concerning the effect of the program/policy by racial, ethnic, gender identity, national origin, income level, disability, sexual orientation, or other existing disparities? – N/A</li> <li>• How will data be collected regarding the effectiveness of this program, policy, or product to ensure it is the right solution? – N/A</li> </ul>

- Describe how this proposal aligns with current City Policies, including the Comprehensive Plan, Sustainability Action Plan, Capital Improvement Program, Neighborhood Master Plans, Council Resolutions, and others? – N/A

**Council Subcommittee Review**

- Please provide a summary of council subcommittee review. If not reviewed by a council subcommittee, please explain why not. – N/A

ORDINANCE NO. C36599

An ordinance updating the annual City of Spokane property tax levy for 2025.

WHEREAS, the Spokane City Council, the governing body of the City of Spokane, a taxing district (“District” or “City”) of the State of Washington, has met and considered its budget for the calendar year 2025, holding public hearings thereon; and

WHEREAS, the District’s actual regular levy amount from the previous year (2024) was \$67,864,218.53 exclusive of administrative refunds; and

WHEREAS, the City Council, after hearing and after duly considering all relevant evidence and testimony presented, has determined that the City of Spokane requires a regular levy as provided hereafter, as well as an EMS levy as provided hereafter, both of which include an increase in property tax revenue from the previous year, and amounts resulting from the addition of new construction and improvements to property and any increase in the value of state-assessed property, and amounts authorized by law as a result of any annexations that have occurred and refunds made, and authorized refunds, in order to discharge the expected expenses and obligations of the City and in its best interest; and

WHEREAS, the District population is more than 10,000; Now, Therefore,

The City of Spokane does ordain:

**Section 1. Regular Levy.**

- A. An increase in the regular annual property tax levy is hereby authorized for the levy to be collected in the 2025 tax year, said increase to be in the amount of \$678,642.19, which is a percentage increase of 1% from the previous year’s actual levy, prior to the inclusion of administrative refunds.
- B. This increase is exclusive of additional revenue in 2025 resulting from new construction, improvements to property, newly constructed wind turbines, increases in the value of state assessed property, and any annexations that have occurred and refunds made or amounts as required or permitted by law.
- C. Resolution No. 2014-0085 concerning a levy lid lift for improved and integrated streets, passed by the Spokane City Council on July 28, 2014, and approved by the voters in the election of November 4, 2014, replaces the existing \$0.57 property tax assessment for repayment of the 2004 street bond beginning in 2015. The voter approved Measure authorizes a levy lid lift of up to \$0.57 per \$1,000 of assessed valuation, in the first year, resulting in no net increase in the 2015 tax rate. This voter approved levy will remain in effect for 20 years.
- D. Resolution No. 2023-0094 concerning a levy for library services, passed by the Spokane City Council on December 4, 2023, and approved by the voters in the

election of February 13, 2024, provides for an increase in the regular property tax levy in excess of state law beginning in 2025. The voter approved Measure authorizes an increase in the regular property tax levy of up to \$0.07 per \$1,000 of assessed valuation. This voter approved levy will remain in effect for a period of three years.

- E. The total regular property tax levy for 2025, including amounts estimated for new construction, annexations, refunds, any other add-ons, and the voter approved levy for library services, is estimated at \$70,475,000 and is a percentage increase of 3.85% from the previous year's actual levy prior to the inclusion of 2024 administrative refunds. Inclusive of 2024 administrative refunds, the 2025 levy represents a 3.05% increase.

## **Section 2. Public Safety Levy Lid Lift (Regular Levy).**

- A. Resolution No. 2018-0103 concerning a levy for police and fire personnel and funding crime reduction programs, passed by the Spokane City Council on December 10, 2018 and approved by the voters in the election of February 12, 2019, provides for an increase in the regular property tax levy in excess of state law beginning in 2020. The voter approved Measure authorizes an increase in the regular property tax levy of up to \$0.30 per \$1,000 of assessed valuation. This voter approved levy will remain in effect in perpetuity.
- B. As stated in Resolution No. 2018-0103, this levy lid lift is a Permanent Single Year Levy Lid Lift. Pursuant to RCW 85.55.050(1), the dollar amount collected in 2020 shall be used for the purpose of computing the limitations of the Public Safety lid lift for subsequent levies in 2021 and each subsequent year thereafter.
- C. An increase in the Public Safety Levy Lid Lift property tax levy is hereby authorized for the levy to be collected in the 2025 tax year, said increase to be in the amount of \$69,205.18, which is a percentage increase of 1% from the previous year's actual levy, prior to the inclusion of administrative refunds.
- D. This increase is exclusive of additional revenue in 2025 resulting from new construction, improvements to property, newly constructed wind turbines, increase in the value of state assessed property, and any annexations that have occurred and refunds made or amounts as required or permitted by law. The total Public Safety Levy Lid Lift levy for 2025, including amounts we have estimated for new construction, annexations, refunds, and other add-ons, is estimated at \$7,055,000 and is a percentage increase of 1.14% from the previous year levy of \$6,975,439.

**Section 3. Existing GO Bonds.**

In the case of the tax levied to raise \$10,750,775 for Principal and Interest on the City of Spokane’s outstanding General Obligation Bonds, the County Assessor, in spreading the tax upon the rolls shall determine the dollar rate required.

**Section 4. EMS Levy.**

Ordinance C-36175 concerning a levy for emergency medical services (EMS), passed by the Spokane City Council on February 14, 2022 and approved by the voters in the election of April 26, 2022, provides for a levy for six consecutive years beginning in 2023, with the rate in the first year being 50 cents per \$1,000 of assessed valuation.

- A. As required by RCW 84.55.120, this ordinance must specifically state the dollar increase requested, as well as the percent change from the previous year. For 2025 the City is requesting an increase of \$172,015.82 which is a 1% increase over the 2024 EMS Levy.
- B. This increase is exclusive of additional revenue in 2025 resulting from new construction, improvements to property, newly constructed wind turbines, increase in the value of state assessed property, and any annexations that have occurred and refunds made or amounts as required or permitted by law. The total EMS levy for 2025, including amounts we have estimated for new construction, annexations, refunds, and other add-ons, is estimated at \$17,580,000 and is a percentage increase of 1.51% from the previous year levy of \$17,318,372.

**Section 5. Certification; Filing.**

The City Council certifies all information as stated herein. Appropriate City staff is directed to transmit all required information required to the Clerk of Spokane County Board of County Commissioners and County Assessor, including budget estimates of amounts to be raised by taxation on assessed value of property (RCW 84.55.020), estimated beginning and ending cash balances (RCW 84.52.025), and the amount of taxes levied on assessed value within the City (RCW 84.52.070). Pursuant to Section 19 of the City Charter, this measure takes effect immediately on first reading and passage.

Passed by the City Council on \_\_\_\_\_.

\_\_\_\_\_  
Council President

Attest:

Approved as to form:

\_\_\_\_\_  
City Clerk

\_\_\_\_\_  
Assistant City Attorney

\_\_\_\_\_  
Mayor

\_\_\_\_\_  
Date