

CITY OF SPOKANE



REGARDING CITY COUNCIL MEETINGS

City Council's standing committee meetings, Briefing Sessions, Legislative Sessions and study sessions are held in City Council Chambers – Lower Level of City Hall, 808 W. Spokane Falls Blvd.

City Council Members, City staff, presenters and members of the public have the option to participate virtually via WebEx during all meetings, with the exception of Executive Sessions which are closed to the public. Call in information for the August 12, 2024, meetings is below. All meetings will be streamed live on Channel 5 and online at <https://my.spokanecity.org/citycable5/live> and <https://www.facebook.com/spokanecitycouncil>.

WebEx call in information for the week of August 12, 2024:

3:30 p.m. Briefing Session: 1-408-418-9388; access code: 249 250 76017; password: 0320

6:00 p.m. Legislative Session: 1-408-418-9388; access code: 248 255 91344; password: 0320

Thursday Study Session: 1-408-418-9388; access code: 249 143 67432; password: 0320

To participate in public comment (including Open Forum):

Testimony sign-up is open beginning at 5:00 p.m. on Friday, August 9, 2024, and ending at 6:00 p.m. on Monday, August 12, 2024, via the online testimony sign-up form link which can be accessed by clicking <https://forms.gle/Vd7n381x3seaL1NW6> or in person outside council chambers beginning at 8:00 a.m. on August 12, 2024. You must sign up by 6:00 p.m. to be called on to testify. (If you are unable to access the form by clicking the hyperlink, please copy and paste the link address into your browser window.) Instructions for participation are provided on the form when you sign up.

The open forum is a limited public forum; all matters discussed in the open forum shall relate to the affairs of the City and not relating to the current or advance agendas, pending hearing items, or initiatives or referenda in a pending election. "Affairs of the city" shall include (i) matters within the legislative, fiscal or regulatory purview of the city, (ii) any ordinance, resolution or other official act adopted by the city council, (iii) any rule adopted by the city, (iv) the delivery of city services and operation of city departments, (v) any act of members of the city council, the mayor or members of the administration, or (vi) any other matter deemed by the council president to fall within the affairs of the city, which determination may be overridden by majority vote of the council members present. Individuals speaking during the open forum shall address their comments to the council president and shall maintain decorum as laid out in Rule 2.15 (Participation by Members of the Public in Council Meetings).

**CITY COUNCIL MEETINGS
RULES – PUBLIC DECORUM**

Strict adherence to the following rules of decorum by the public will be observed and adhered to during City Council meetings, including open forum, public comment period on legislative items, and Council deliberations:

- 1. No Clapping!**
- 2. No Cheering!**
- 3. No Booing!**
- 4. No public outbursts!**
- 5. Two-minute time limit for comments made during open forum, and three-minute time limit on public testimony regarding legislative items!**

In addition, please silence your cell phones when entering the Council Chambers!

Further, keep the following City Council Rules in mind:

Rule 2.2 OPEN FORUM

- A. After the conclusion of all legislative business, the council shall recess briefly and then convene for an open forum, unless a majority of council members vote otherwise. The open forum shall have twenty (20) spaces available. The individuals assigned to the twenty (20) spaces available will be chosen at random, with preference given to individuals who have not spoken at open forum during that calendar month. The council shall conclude open forum after twenty (20) speakers unless a majority of council members vote to allow additional speakers. The city clerk and other staff shall not be required to remain in attendance during the open forum. Nothing in this Rule 2.2 shall be deemed to require open forum or the legislative session to continue after 10:00 p.m., or to require open forum during a council “Town Hall” meeting contrary to Rule 2.14.F.
- B. Members of the public can sign up for open forum beginning no later than 5:00 p.m. on the Friday immediately preceding the legislative session and ending at 6:00 p.m. on the date of the meeting via the virtual testimony form linked in the meeting packet or in person outside council chambers beginning at 8:00 a.m. on the day of the legislative session. Speakers must sign themselves in using a name. Members of the public who are unable to sign up during the sign-up period or who attempt to sign up late will be added to the list of speakers at the discretion of the chair, or their designee. The order of the speakers will be determined at the discretion of the chair, taking into account any special accommodations for persons of limited English proficiency as provided in Rule 2.2.F below. Each speaker shall be limited to no more than two (2) minutes unless a majority of the council members in attendance vote on an alternate time limit.
- C. No action, other than a statement of council members’ intent to address the matter in the future, points of order, or points of information will be taken by council members during an open forum.
- D. The open forum is a limited public forum and all matters discussed in the open forum shall relate to the affairs of the city. “Affairs of the city” shall include (i) matters within the legislative, fiscal or regulatory purview of the city, (ii) any ordinance, resolution or other official act adopted by the city council, (iii) any rule adopted by the city, (iv) the delivery of city services and operation of city departments, (v) any act of members of the city council, the mayor or members of the administration, or (vi) any other matter deemed by the council president to fall within the affairs of the city, which determination may be overridden by majority vote of the council members present. Absent permission of the chair, no person shall be permitted to speak in open forum regarding items on that week’s current agenda or the next week’s advanced agenda, pending hearing items, or initiatives or referenda in a pending election. Legal or personal matters between private parties that do not impact the governance of the City of Spokane are not a permissible topic of open forum testimony.
- E. No person shall be permitted to display visual information during open forum, including but not limited to presentations, videos, or other media; however, members of the public may share this information with the council by emailing them at citycouncil2@spokanecity.org. Individuals speaking during open forum shall address their comments to the council president, and speakers as well as members of the audience shall comply with Rule 2.15 (Participation by Members of the Public in Council Meetings).
- F. Participation of individuals with limited English language proficiency in open forum shall be accommodated to the extent set forth in Rule 2.15.J.

Rule 2.7 SERVICE ANIMALS AT CITY COUNCIL MEETINGS

- A. For purposes of these Rules, only dogs that are individually trained to do work or perform tasks for a person with a disability are recognized as service animals. Dogs or other animals whose sole function is to provide comfort or emotional support do not qualify as service animals under these Rules. Service animals are permitted to accompany people with disabilities in City Council meetings, as well as all areas where members of the public are allowed to go.

- B. Service animals must, at all times while present in a City Council meeting, be harnessed, leashed, or tethered, unless these devices interfere with the service animal's work or the individual's disability prevents using these devices, in which case, the individual must maintain control of the animal through voice, signal, or other effective controls.

Rule 2.15 PARTICIPATION OF MEMBERS OF THE PUBLIC IN COUNCIL MEETINGS

The council encourages public participation in the legislative process. Council meetings shall be conducted in a manner that provides the opportunity for all attendees to hear, see and participate in the proceedings to the extent provided in these Rules and applicable city, state, and federal law. Speech or conduct that disrupts, disturbs, or otherwise impedes the orderly conduct of any council meeting is prohibited. In addition to these general principles governing public participation, the following specific rules apply:

- A. Members of the public may address the council regarding the following items during the council's legislative session: the consent agenda as a whole, all first reading ordinances together (with the exception of first reading ordinances associated with hearings, which shall be taken separately), final readings of regular and special budget ordinances, emergency ordinances, hearing items, special considerations, and other items before the city council requiring council action, except those that are adjudicatory or solely administrative in nature. This rule shall not limit the public's right to speak on issues that are not part of the current or advanced agendas during open forum.
- B. No member of the public may speak without first being recognized for that purpose by the chair. Except for named parties to an adjudicative hearing, a person may be required to sign a sign-up sheet and provide their city of residence as a condition of recognition. Council members must be recognized by the chair for the purpose of obtaining the floor.
- C. Each person speaking in a public council meeting shall verbally identify themselves by name, city of residence, and, if appropriate, representative capacity.
- D. Each speaker shall follow all written and verbal instructions so that verbal remarks are electronically recorded, and documents submitted for the record are identified and marked by the clerk.
- E. Those who wish to provide commentary but do not wish to give verbal comments at the podium may provide written comments to the council via letter or electronic mail.
- F. No person shall be permitted to conduct demonstrations, display banners, hold signs, applaud or boo speakers, use profanity, vulgar language or obscene speech, yell or make comments that attack or verbally insult any individual, or engage in other such disorderly conduct that disrupts, disturbs, or otherwise impedes the orderly conduct of the proceedings.
- G. Standing is permitted so long as doing so maintains compliance with applicable fire codes and the Americans with Disability Act (ADA), does not interfere with reserved seating areas, and does not impede access to entrances and exits to the Council Chambers, aisles, or pathways inside the Council Chambers. Attendees shall be mindful not to obstruct the views of others in Council Chambers when standing.
- H. A speaker asserting a statement of fact may be asked by a council member to document and identify the sources of the factual datum being asserted.
- I. When addressing the council, members of the public shall direct all remarks to the council president, shall refrain from remarks directed personally to any council member or any other individual, and shall confine remarks to the matters that are specifically before the council at that time.
- J. City employees or city officials (including members of city boards and commissions) may participate in public comment, including open forum, providing they are in compliance with the City of Spokane Code of Ethics and they do the following:
 - 1. Announce at the beginning of their testimony that they are there in their personal capacity or their capacity as a member of a relevant board, commission, committee or community group;
 - 2. Protect confidential information, including, but not limited to, confidential financial information and attorney-client communications;
 - 3. Do not use, or be perceived to use, city funds, including giving testimony during paid work time or while in uniform; or city property, including using a city-issued computer or cell phone, in giving testimony.
- K. When any person, including members of the public, city staff, and others, are addressing the council, council members shall observe the same decorum and process as the rules require among the members *inter se*. That is, a council member shall not engage the person addressing the council in colloquy but shall speak only when granted the floor by the council president. All persons and/or council members shall not interrupt one another. The duty of mutual respect and avoiding unlawful harassment set forth in Rule 1.2 and the rules governing debate set forth in *Robert's Rules of Order, Newly Revised*, shall extend to all speakers before the city council. The city council's policy advisor and/or a city attorney shall, with the assistance of council staff, assist the council president to ensure that all individuals desiring to speak shall be identified,

appropriately recognized, and provided the opportunity to speak. All persons attending city council meetings or city council sponsored meetings shall refrain from harassing other attendees or risk being removed and/or prohibited from attending future meetings.

- L. The city council intends to fully comply with chapter 18.11 SMC, Language Access in Municipal Proceedings. Rules regarding participation of individuals in council proceedings, including legislative sessions and open forum, shall be deemed amended to conform to any Language Access Plan adopted by the council pursuant to SMC 18.11.030. Except as otherwise provided in an adopted Language Access Plan, individuals with limited English language proficiency are encouraged to contact the council office director at least five (5) days prior to a scheduled legislative session for assistance with the signing up to testify or to arrange translation or interpretation assistance.
- M. City council legislative sessions are regularly video and audio recorded and available online (<https://vimeo.com/spokanecitycouncil>). Members of the public may also photograph or film council proceedings so long as doing so maintains compliance with applicable fire codes and the Americans with Disability Act (ADA), does not interfere with reserved seating areas, and does not impede access to entrances and exits to the Council Chambers, aisles, or pathways inside the Council Chambers. Attendees shall be mindful not to obstruct the views of others in Council Chambers when photographing or recording. No flash photography or other lighting is permitted.
- N. RCW 42.17A.555 generally prohibits the use of city facilities for electioneering. Therefore, no person may use the council meeting or facilities for the purpose of assisting a campaign for election of any person to any office, or for the promotion of or opposition to any ballot proposition. In this context, the term “facilities” includes council chambers, the council gallery and the speaking opportunities available through the public comment and open forum procedures set forth in these rules.

Rule 2.16 PUBLIC TESTIMONY REGARDING LEGISLATIVE AGENDA ITEMS – TIME LIMITS

- A. Members of the public can sign up to give testimony beginning no later than 5:00 p.m. on the Friday immediately preceding the legislative session and ending at 6:00 p.m. on the date of the meeting via the online testimony sign-up form linked in the meeting packet or in person outside council chambers beginning at 8:00 a.m. on the day of the legislative session. Speakers must sign in using a name. Members of the public who are unable to sign up during the sign-up period or who attempt to sign up late will not be added to the list of speakers. The order of the speakers shall be determined at the discretion of the chair.
- B. The city council shall take public testimony on all matters included on its legislative agenda as described at Rule 2.15(A), with those exceptions stated in Rule 2.16(B). Public testimony shall be limited to the final council action, except that public testimony shall be allowed at the first reading of ordinances. Public testimony shall be limited to three (3) minutes per speaker. The chair, absent a majority vote of the council, has the authority to lower the three (3) minutes per speaker time limit by announcing the new, lower time limit at the legislative session. The chair may allow additional time if the speaker is asked to respond to questions from the council. Public testimony and consideration of an item may be extended to a subsequent meeting by a majority vote of the council. Testimony on a legislative item deferred to a future date certain shall be taken on the future date, unless testimony on the date of deferral is allowed by the Council President.
- C. No public testimony shall be taken on oral amendments to consent or legislative agenda items, votes to override a mayoral veto, or solely procedural, parliamentary, or administrative matters of the council.
- D. Public testimony will be taken on consent and legislative items that are moved to council’s regular briefing session or study session unless a majority of council votes otherwise during the meeting in which the items are moved.
- E. For legislative or hearing items that may affect an identifiable individual, association, or group, the following procedure may be implemented at the discretion of the council president:
 - 1. Following an assessment by the chair of factors such as complexity of the issue(s), the apparent number of people indicating a desire to testify, representation by designated spokespersons, etc., the chair shall, in the absence of objection by the majority of the council present, impose the following procedural time limitations for taking public testimony regarding legislative matters:
 - a. There shall be up to fifteen (15) minutes for staff, board, or commission presentation of background information, if any.
 - b. The designated representative of the proponents of the issue shall speak first and may include within their presentation the testimony of expert witnesses, visual displays, and any other reasonable methods of presenting the case. Up to thirty (30) minutes may be granted for the proponent’s presentation. If there be more than one designated representative, they shall allocate the allotted time between or among themselves.
 - c. Following the presentation of the proponents of the issue, three (3) minutes shall be granted for any other person not associated with the designated representative of the proponents who wishes to

Speak on behalf of the proponent's position.

- d. The designated representative, if any, of the opponents of the issue shall speak following the presentation of the testimony of expert witnesses, visual displays, and any other reasonable methods of presenting the case. The designated representative(s) of the opponents shall have the same amount of time which was allotted to the proponents.
 - e. Following the presentation by the opponents of the issue, three (3) minutes shall be granted for any other person not associated with the designated representative of the opponents who wishes to speak on behalf of the opponents' position.
 - f. Up to ten (10) minutes of rebuttal time may be granted to the designated representative for each side, the proponents speaking first, the opponents speaking second.
2. In the event the party or parties representing one side of an issue has a designated representative and the other side does not, the chair shall publicly ask the unrepresented side if they wish to designate one or more persons to utilize the time allotted for the designated representative. If no such designation is made, each person wishing to speak on behalf of the unrepresented side shall be granted three (3) minutes to present their position, and no additional compensating time shall be allowed due to the fact that the side has no designated representative.
 3. In the event there appears to be more than two groups wishing to advocate their distinct positions on a specific issue, the chair may grant the same procedural and time allowances to each group or groups, as stated previously.
 4. In the event that the side for which individuals wish to speak is not identified, those wishing to give testimony shall be granted three (3) minutes to present their position after all sides have made their initial presentations and before each side's rebuttal period.
- F. The time taken for staff or council member questions and responses thereto shall be in addition to the time allotted for any individual or designated representative's testimony.
 - G. No person shall be permitted to display visual information during their testimony, including but not limited to presentations, videos, or other media; however, members of the public may share this information with the council by emailing them at citycouncil2spokanecity.org.
 - H. In addition to in-person or remote verbal testimony, testimony may also be submitted by mail to City Council Office, Spokane City Hall, 808 W. Spokane Falls Blvd., Spokane, WA, 99201, by email to all council members, or via the contact form on the council's website.¹

¹ <https://my.spokanecity.org/citycouncil/members/>

THE CITY OF SPOKANE



CURRENT COUNCIL AGENDA

MEETING OF MONDAY, AUGUST 12, 2024

MISSION STATEMENT

**TO DELIVER EFFICIENT AND EFFECTIVE SERVICES
THAT FACILITATE ECONOMIC OPPORTUNITY
AND ENHANCE QUALITY OF LIFE.**

MAYOR LISA BROWN

COUNCIL PRESIDENT BETSY WILKERSON

COUNCIL MEMBER JONATHAN BINGLE

COUNCIL MEMBER MICHAEL CATHCART

COUNCIL MEMBER PAUL DILLON

COUNCIL MEMBER KITTY KLITZKE

COUNCIL MEMBER LILI NAVARRETE

COUNCIL MEMBER ZACK ZAPPONE

**CITY COUNCIL CHAMBERS
CITY HALL**

**808 W. SPOKANE FALLS BLVD.
SPOKANE, WA 99201**

City of Spokane Guest Wireless access for Council Chambers for August 12, 2024:

Username: **COS Guest**

Password: **K8vCr44y**

**Please note the space in username.
Both username and password are case sensitive.**

LAND ACKNOWLEDGEMENT

We acknowledge that we are on the unceded land of the Spokane people. And that these lands were once the major trading center for the Spokanes as they shared this place and welcomed other area tribes through their relations, history, trade, and ceremony. We also want to acknowledge that the land holds the spirit of the place, through its knowledge, culture, and all the original peoples Since Time Immemorial.

As we take a moment to consider the impacts of colonization may we also acknowledge the strengths and resiliency of the Spokanes and their relatives. As we work together making decisions that benefit all, may we do so as one heart, one mind, and one spirit.

We are grateful to be on the shared lands of the Spokane people and ask for the support of their ancestors and all relations. We ask that you recognize these injustices that forever changed the lives of the Spokane people and all their relatives.

We agree to work together to stop all acts of continued injustices towards Native Americans and all our relatives. It is time for reconciliation. We must act upon the truths and take actions that will create restorative justice for all people.

Adopted by Spokane City Council on the 22nd day of March, 2021
via Resolution 2021-0019

BRIEFING AND LEGISLATIVE SESSIONS

The Briefing Session is open to the public, but will be a workshop meeting. Discussion will be limited to Council Members and appropriate Staff and Counsel. The Legislative Session is also open to the public and public comment will be taken on Legislative Session items, except those that are adjudicatory or solely administrative in nature. Following the conclusion of the Legislative Agenda, an Open Forum will be held unless a majority of Council Members vote otherwise. Please see additional Open Forum information that appears at the end of the City Council agenda.

SPOKANE CITY COUNCIL BRIEFING SESSIONS (BEGINNING AT 3:30 P.M. EACH MONDAY) AND LEGISLATIVE SESSIONS (BEGINNING AT 6:00 P.M. EACH MONDAY) ARE BROADCAST LIVE ON CITY CABLE CHANNEL FIVE AND STREAMED LIVE ON THE CHANNEL FIVE WEBSITE. THE SESSIONS ARE REPLAYED ON CHANNEL FIVE ON THURSDAYS AT 6:00 P.M. AND FRIDAYS AT 10:00 A.M.

ADDRESSING THE COUNCIL

- No member of the public may speak without first being recognized for that purpose by the Chair. Except for named parties to an adjudicative hearing, a person may be required to sign a sign-up sheet and provide their city of residence as a condition of recognition. Council Members must be recognized by the chair for the purpose of obtaining the floor.
- Each person speaking at the public microphone shall verbally identify themselves by name, city of residency and, if appropriate, representative capacity.
- Each speaker shall follow all written and verbal instructions so that verbal remarks are electronically recorded, and documents submitted for the record are identified and marked by the Clerk. (If you are submitting letters or documents to the Council Members, please provide a minimum of ten copies via the City Clerk. The City Clerk is responsible for officially filing and distributing your submittal.)
- In order that evidence and expressions of opinion be included in the record and that decorum befitting a deliberative process be maintained, no modes of expression including but not limited to demonstrations, banners, signs, applause, profanity, vulgar language, or personal insults will be permitted. To prevent disruption of council meetings and visual obstruction of proceedings, members of the audience shall remain seated during council meetings.
- A speaker asserting a statement of fact may be asked to document and identify the source of the factual datum being asserted.
- When addressing the Council, members of the public shall direct all remarks to the Council President, and shall confine their remarks to the matters that are specifically before the Council at that time or, if speaking during Open Forum, shall confine their remarks to affairs of the city.
- City staff may participate in public comment, including open forum, providing they are in compliance with the City of Spokane Code of Ethics and they follow the steps outlined in the City Council Rules of Procedure.

SPEAKING TIME LIMITS: Unless the time limit is adjusted by a majority vote of the Council, each person addressing the Council shall be limited to a two-minute speaking time during Open Forum and a three-minute speaking time for other matters. The chair may allow additional time if the speaker is asked to respond to questions from the Council. Public testimony and consideration of an item may be extended to a subsequent meeting by a majority vote of the Council. Note: No public testimony shall be taken on amendments to consent or legislative agenda items, or solely procedural, parliamentary, or administrative matters of the Council, including veto overrides.

CITY COUNCIL AGENDA: The City Council Advance and Current Agendas may be obtained prior to Council Meetings by accessing the City website at <https://my.spokanecity.org/citycouncil/documents/>.

BRIEFING SESSION

(3:30 p.m.)

(Council Chambers Lower Level of City Hall)
(No Public Testimony Taken)

ROLL CALL OF COUNCIL

INTERVIEWS OF NOMINEES TO BOARDS AND COMMISSIONS

COUNCIL OR STAFF REPORTS OF MATTERS OF INTEREST

ADVANCE AGENDA REVIEW (Staff or Council Member briefings and discussion)

APPROVAL BY MOTION OF THE ADVANCE AGENDA

CURRENT AGENDA REVIEW (Presentation of any new background information and discussion of any adjustments)

EXECUTIVE SESSION

(Closed Session of Council)

(Executive Session may be held or reconvened during the 6:00 p.m. Legislative Session)

LEGISLATIVE SESSION

(6:00 P.M.)

(Council Reconvenes in Council Chamber)

PLEDGE OF ALLEGIANCE

WORDS OF INSPIRATION AND SPECIAL INTRODUCTIONS

ROLL CALL OF COUNCIL

PROCLAMATIONS AND SALUTATIONS

REPORTS FROM COMMUNITY ORGANIZATIONS

ANNOUNCEMENTS

(Announcements regarding Changes to the City Council Agenda)

BOARDS AND COMMISSIONS APPOINTMENTS

(Includes Announcements of Boards and Commissions Vacancies)

APPOINTMENTS

RECOMMENDATION

Community, Housing, and Human Services Board: One Confirm CPR 2012-0033
Appointment

CONSENT AGENDA

The consent agenda consists of purchases and contracts for supplies and services provided to the city, as well as other agreements that arise (such as settlement or union agreements), and weekly claims and payments of previously approved obligations and biweekly payroll claims against the city. Any agreement over \$50,000 must be approved by the city council. Typically, the funding to pay for these agreements has already been approved by the city council through the annual budget ordinance, or through a separate special budget ordinance. If the contract requires a new allocation of funds, that fact usually will be indicated in the summary of the contract in the consent agenda.

Unless a council member requests that an item be considered separately, the council approves the consent agenda as a whole in a single vote. Note: The consent agenda is no longer read in full by the city clerk. The public is welcome to testify on matters listed in the consent agenda, but individual testimony is limited to three minutes for the entire consent agenda.

REPORTS, CONTRACTS AND CLAIMS

RECOMMENDATION

- | | | |
|---|----------------|---------------------------------------|
| <p>1. Two-year Value Blanket with Pomp Tire Services (Spokane) for purchase of tires and tire-related products for multiple departments—\$800,000 annually. (Council Sponsors: Council President Wilkerson and Council Members Cathcart and Zappone)
Jason Nechanicky</p> | <p>Approve</p> | <p>OPR 2024-0606</p> |
| <p>2. Personal Service Agreement with Pomp Tire Services (Spokane) for miscellaneous tire services for multiple departments from July 1, 2024, through June 30, 2029—\$380,000 annually (plus tax, if applicable). (Council Sponsors: Council President Wilkerson and Council Members Cathcart and Zappone)
Jason Nechanicky</p> | <p>Approve</p> | <p>OPR 2024-0607</p> |
| <p>3. Contract Amendment with Applied Industrial Technologies (Spokane) for conveyor belt services at the Waste to Energy Facility from July 1, 2023, to June 30, 2025—additional \$150,000 (plus tax) due to unplanned but necessary repairs to the ash system.</p> | <p>Approve</p> | <p>OPR 2023-0686
IPWQ 5891-23</p> |

Total contract amount: \$360,000 (plus tax). (Council Sponsors: Council President Wilkerson and Council Members Bingle and Klitzke)

David Paine

- | | | |
|--|---|--------------------------------------|
| <p>4. Master Personal Services Agreement with Absolute Drug Testing, LLC (Coeur d’Alene, ID) for drug and alcohol testing services for Municipal Court from July 1, 2024, through June 30, 2025, with options for up to four additional one-year renewals—\$250,000 (plus tax, if applicable). (Council Sponsors: Council President Wilkerson and Council Members Dillon and Cathcart)</p> | <p>Approve</p> | <p>OPR 2024-0608
RFP 6102-24</p> |
| <p>Michael Diamond</p> | | |
| <p>5. Joint application of Empire Health Foundation as the proposed operator and Revive Counseling as the housing navigator and primary service provider to support the continued decommissioning of the Trent Resource and Assistance Center from July 1, 2024, through June 30, 2025—\$3,850,000. (Council Sponsors: Council Members Zappone, Bingle, and Klitzke)</p> | <p>Approve &
Authorize
Contract</p> | <p>OPR 2024-0609</p> |
| <p>Arielle Anderson</p> | | |
| <p>6. Service Agreement with Gartner, Inc (Stamford, CT) for consulting, research, and related services for City of Spokane Finance leadership from August 1, 2024, through July 31, 2025—\$150,128. (Council Sponsors: Council President Wilkerson and Council Members Cathcart and Zappone)</p> | <p>Approve</p> | <p>OPR 2024-0610</p> |
| <p>Matt Boston</p> | | |
| <p>7. Five-year Contracts for the Mail Center from September 24, 2024, through September 23, 2029, with:</p> | <p>Approve
All</p> | |
| <p>a. Canon Solutions America, Inc. (Melville, NY) for lease of Riso Comcolor 9730 printer—\$147,720 (plus tax, if applicable).</p> | | <p>OPR 2024-0611</p> |
| <p>b. Quadiant Leasing USA, Inc. (Milford, CT) for lease of mail and inserter machines and associated software—\$236,987.40 (plus tax, if applicable.)</p> | | <p>OPR 2024-0612</p> |
| <p>(Council Sponsors: Council President Wilkerson and Council Members Cathcart and Zappone)</p> | | |
| <p>Michael Sloon</p> | | |
| <p>8. Contract Amendment and Extension with GSI Water Solutions, Inc. (Portland, OR) for Well Electric New Well Field Study from July 1, 2024, through December 31, 2025—\$132,900 (plus tax, if applicable). (Council Sponsors: Council President Wilkerson and Council Members Bingle and Klitzke)</p> | <p>Approve</p> | <p>OPR 2021-0713
ENG 2018099</p> |

Nate Sulya

- 9. Reimbursement Agreement with Spokane Transit Authority for the design phase of the Division Street Bus Rapid Transit Project Development—\$100,000. (Council Sponsors: Council President Wilkerson and Council Members Bingle and Klitzke)
Katherine Miller Approve OPR 2024-0613
- 10. Preventative Maintenance Agreement with ACI Northwest, Inc. (Dalton Gardens, ID) for HVAC preventative maintenance and on-call repair services at the Riverside Park Water Reclamation Facility from August 1, 2024, through July 31, 2027—\$360,000 (plus tax). (Council Sponsors: Council President Wilkerson and Council Members Bingle and Klitzke)
Kyle Arrington Approve OPR 2024-0614
IPWQ 6154-24
- 11. Report of the Mayor of pending: Approve & Authorize Payments CPR 2024-0002
 - a. Claims and payments of previously approved obligations, including those of Parks and Library, through July 19, 2024, total \$7,532,086.99, with Parks and Library claims approved by their respective boards. Warrants excluding Parks and Library total \$6,815,535.78.
 - b. Claims and payments of previously approved obligations, including those of Parks and Library, through July 26, 2024, total \$14,926,503.07, with Parks and Library claims approved by their respective boards. Warrants excluding Parks and Library total \$14,575,604.61.
 - c. Claims and payments of previously approved obligations, including those of Parks and Library, through August 2, 2024, total \$9,499,707.31, with Parks and Library claims approved by their respective boards. Warrants excluding Parks and Library total \$9,082,447.55.
 - d. Payroll claims of previously approved obligations through July 20, 2024: \$9,666,801.54.
 - e. Payroll claims of previously approved obligations through August 3, 2024: \$9,978,036.23.
- 12. a. City Council Meeting Minutes: July 8, July 15, and July 22, 2024. Approve All CPR 2024-0013

b. City Council Finance and Administration
Standing Committee Meeting Minutes:
July 22, 2024.

CPR 2024-0015

LEGISLATIVE AGENDA

NO SPECIAL BUDGET ORDINANCES

NO EMERGENCY ORDINANCES

RESOLUTIONS & FINAL READING ORDINANCES

(Require Four Affirmative, Recorded Roll Call Votes)

- RES 2024-0073 Relating to modification of the City of Spokane's Retail Water Service Area (RWSA) to amend the RWSA boundaries to include areas within the current Spokane County Urban Growth Area (UGA) boundaries and authorizing amendment of the City's RWSA map on file with the Washington State Department of Health. (Council Sponsors: Council President Wilkerson and Council Members Bingle and Klitzke)
Marlene Feist
- RES 2024-0074 Expressing support for the federal administration's new executive directive to keep immigrant and noncitizen families together, for local efforts to provide immigrant services, and for amending the City's federal legislative agenda to include support for federal relief of immigrant legal services. (Council Sponsors: Council Members Navarrete, Dillon, and Klitzke)
Andres Grageda
- RES 2024-0075 Approving the appointment of Christine Shisler as the Retirement Director for the City of Spokane. (Council Sponsors: Council President Wilkerson and Council Members Cathcart and Zappone)
Adam McDaniel
- RES 2024-0076 Approving the appointment of Laz Martinez as the Director of Information and Technology for the City of Spokane. (Council Sponsors: Council President Wilkerson and Council Members Cathcart and Zappone)
Adam McDaniel
- RES 2024-0077 Acknowledging the recommendation of the Neighborhood Project Advisory Committee for the West Quadrant Tax Increment Financing district and accepting the use of \$190,000 in TIF funding for public improvements to be installed as part of the NATIVE Project Children and Youth Behavioral Health Project. (Council Sponsors: Council Members Zappone, Bingle, and Klitzke)
Kevin Freibott

ORD C36120 Vacating the east 55 feet of Adams Street from the south line of Third Avenue to the north line of I-90, together with the alley between Third Avenue and I-90, from the east line of Adams Street to the west line of Jefferson Street. (First Reading held October 25, 2021) (Deferred from July 15, 2024, Agenda) (Council Sponsors: Council Members Zappone and Klitzke)

Eldon Brown

ORD C36548 (To be considered under Hearings Item H1.)

ORD C36549 Relating to the human rights and basic dignity of individuals experiencing homelessness; amending sections 9.02.050, 18.01.010, 18.01.020, and 18.01.030 of the Spokane Municipal Code; and enacting a new Section 18.05.040 of the Spokane Municipal Code. (Council Sponsors: Council Members Navarrete and Klitzke)

Andres Grageda

Navarrete Proposed Amendment:

- Request motion to amend previous version of Final Reading Ordinance C36549 with an updated amended version filed August 8, 2024, and included in agenda packet under Final Reading Ordinance C36549.

Cathcart Proposed Amendment:

- Request motion to amend previous version of Final Reading Ordinance C36549 with an updated amended version filed August 8, 2024, and included in agenda packet under Final Reading Ordinance C36549.

Dillon/Navarrete Proposed Amendment:

- Request motion to amend previous version of Final Reading Ordinance C36549 with an updated amended version filed August 8, 2024, and included in agenda packet under Final Reading Ordinance C36549.

ORD C36550 Amending Ordinance C26051 that vacated Thirteenth Avenue and Woodland Boulevard from the southeast right of way line of I-90 to the west line of "A" Street, Evergreen Drive from the southeast right of way line of I-90 to the north line of Fourteenth Avenue and the unnamed strip of land south of Lot 12 and north of Lots 17, 18, and 19, Block 16, Woodland Heights Addition, from the west line of Evergreen Drive to the extended west line of said Lots 12 and 17, and providing for an effective date. (Council Sponsors: Council Members Zappone and Klitzke)

Eldon Brown

ORD C36552 (To be considered under Hearings Item H3.a.)

ORD C36553 (To be considered under Hearings Item H3.b.)

- ORD C36554 (To be considered under Hearings Item H3.c.)
- ORD C36555 (To be considered under Hearings Item H3.d.)
- ORD C36556 (To be considered under Hearings Item H3.e.)

FIRST READING ORDINANCES

- ORD C36543 Designating the Lunar New Year, Martin Luther King Jr. Day and Juneteenth as official City of Spokane holidays, making technical corrections to Chapter 03.03 of the Spokane Municipal Code, amending Section 03.03.010 of the Spokane Municipal Code, making technical corrections to Section 03.03.050 of the Spokane Municipal Code and adding a new section 03.03.070 to the Spokane Municipal Code. (Deferred from July 15, 2024, Agenda, during the July 8, 2024, 3:30 p.m. Briefing Session) (Council Sponsors: Council President Wilkerson and Council Member Cathcart)
Council Member Cathcart
- ORD C36544 Prohibiting illegal encampments near facilities offering comprehensive support services and amending Title 12, Chapter 12.02, of the Spokane Municipal Code. (Deferred from July 15, 2024, Agenda, during the July 8, 2024, 3:30 p.m. Briefing Session) (Council Sponsors: Council Members Cathcart and Bingle)
Council Member Cathcart
- ORD C36557 Creating the Climate Resilience and Sustainability Board (CRSB); repealing Chapter 04.36 of Title 04 the Spokane Municipal Code; creating a new Chapter 04.41 to Title 04 of the Spokane Municipal Code. (Council Sponsors: Council President Wilkerson and Council Member Klitzke)
Adam McDaniel and Kelly Thomas
- ORD C36558 Repealing inactive funds; amending Sections 07.08.100, 07.08.119, and 07.08.159; repealing Sections 07.08.105, 07.08.111, 07.08.118, 07.08.120, 07.08.126, 07.08.128, 07.08.142, 07.08.144, 07.08.200, 07.08.308, 07.08.309, and 07.08.410 of the Spokane Municipal Code. (Repeals municipal code sections related to inactive special revenue, debt service, capital projects, and enterprise funds.) (Council Sponsors: Council President Wilkerson and Council Members Cathcart and Zappone)
Adam McDaniel
- ORD C36559 Relating to the membership of the Spokane Employees' Retirement System Board; amending SMC section 4.14.040. (Council Sponsors: Council President Wilkerson and Council Members Cathcart and Zappone)
Adam McDaniel
- ORD C36560 (To be considered under Hearings Item 2.b.)

FURTHER ACTION DEFERRED

NO SPECIAL CONSIDERATIONS

HEARINGS

RECOMMENDATION

- H1. Final Reading Ordinance C36548 relating to the establishment of a sales and use tax deferral program for affordable housing; retitling chapter 08.07D of the Spokane Municipal Code (SMC); and enacting a new chapter 08.07E to Title 08 of the SMC. (Council Sponsors: Council Members Zappone, Bingle, and Klitzke)
Steve MacDonald
Pass Upon Roll Call Vote ORD C36548
- H2. a. Vacation of the alley between Lee Street and Stone Street, from the south line of Broadway Avenue to the north line of Springfield Avenue, as requested by Richard Clemson. Approve Subject to Conditions
- b. First Reading Ordinance C36560 vacating the alley between Lee Street and Stone Street, from the south line of Broadway Avenue to the north line of Springfield Avenue. Further Action Deferred ORD C36560
(Council Sponsors: Council Members Zappone and Klitzke)
Eldon Brown
- H3. Ordinances relating to Spokane Municipal Code updates associated with the South Logan Transit-Oriented Development (TOD) Plan (Final Reading Ordinances C36552 thru C36556) (By votes of 7 to 0, the Plan Commission recommends approval of all five ordinances.) (First Readings held July 22, 2024) (Council Sponsors: Council Member Zappone, Klitzke, Bingle):
 - a. Final Reading Ordinance C36552 relating to maximum residential heights and multi-unit open space standards amending Spokane Municipal Code (SMC) Sections 17C.111.205 and 17C.111.420. Pass upon Roll Call Vote ORD C36552
 - b. Final Reading Ordinance C36553 relating to the Hamilton Form-Based Code amending Spokane Municipal Code (SMC) Chapter 17C.123 Form Based Code Zones. Pass upon Roll Call Vote ORD C36553

- c. Final Reading Ordinance C36554 relating to streamlining and expediting the land use review and approval process by relying on the Final Environmental Impact Statement (FEIS) for the South Logan Transit-Oriented Development (TOD) Plan by adopting a Planned Action; implementing the intent of the recently adopted by resolution South Logan TOD Plan; adopting Spokane Municipal Code (SMC) Chapter 17C.420; and amending Spokane Municipal Code (SMC) Chapter 17A.020. Pass Upon
Roll Call
Vote ORD C36554

- d. Final Reading Ordinance C36555 relating to height and height transition standards amending Spokane Municipal Code (SMC) Sections 17C.111.230 and 17C.120.220. Pass Upon
Roll Call
Vote ORD C36555

- e. Final Reading Ordinance C36556 relating to the Center and Corridor and parking development regulations amending Spokane Municipal Code (SMC) Sections 17C.122.070, 17C.122.090, 17C.230.120, 17C.230.130, and 17C.300.130, repealing Sections 17C.122.080, 17C.122.100, 17C.122.110, and 17C.122T, and adopting new Sections 17C.122.200, 17C.122.210, 17C.122.220, 17C.122.230, 17C.122.240, and 17C.122.250. (As amended on during the July 15, 2024, 3:30 p.m. Briefing Session.) Pass Upon
Roll Call
Vote ORD C36556

KayCee Downey

OPEN FORUM

At the conclusion of legislative business, the Council shall recess briefly and then hold an open public comment period for up to 20 (twenty) speakers, unless a majority of council members vote otherwise. Each speaker is limited to no more than two minutes. In order to participate in Open Forum, you must sign up beginning at 5:00 p.m. on the Friday immediately preceding the legislative session and ending at 6:00 p.m. on the date of the meeting via the virtual testimony form linked in the meeting packet (<https://my.spokanecity.org/citycouncil/documents/>) or in person outside council chambers beginning at 8:00 a.m. on the day of the legislative session. The virtual sign-up form can also be found here: <https://forms.gle/Vd7n381x3seal1NW6>. (If you are unable to access the form by clicking the hyperlink, please copy and paste the link address into your browser window.) Speakers must sign themselves in using a name. The individuals assigned to the twenty (20) spaces available will be chosen at random, with preference given to individuals who have not spoken at open forum during that calendar month. Instructions for virtual participation are provided on the form when you sign up. The Open Forum is a limited public forum; all matters discussed in the open forum shall relate to the affairs of the City other than items appearing on the Current or Advance Agendas, pending hearing items, and initiatives or referenda in a pending election. Individuals speaking during the open forum shall address their comments to the Council President and shall not use profanity, engage in obscene speech, or make personal comment or verbal insults about any individual.

**Motion to Approve Current Agenda for August 12, 2024
(per Council Rule 2.1.B)**

ADJOURNMENT

The August 12, 2024, Regular Legislative Session of the City Council is adjourned to August 19, 2024.

AMERICANS WITH DISABILITIES ACT (ADA) INFORMATION: The City of Spokane is committed to providing equal access to its facilities, programs and services for persons with disabilities. The Spokane City Council Chamber in the lower level of Spokane City Hall, 808 W. Spokane Falls Blvd., is wheelchair accessible and also is equipped with an infrared assistive listening system for persons with hearing loss. Headsets may be checked out (upon presentation of picture I.D.) at the City Cable 5 Production Booth located on the First Floor of the Municipal Building, directly above the Chase Gallery or through the meeting organizer. Individuals requesting reasonable accommodations or further information may call, write, or email Risk Management at 509.625.6221, 808 W. Spokane Falls Blvd, Spokane, WA, 99201; or mLOWmaster@spokanecity.org. Persons who are deaf or hard of hearing may contact Risk Management through the Washington Relay Service at 7-1-1. Please contact us forty-eight (48) hours before the meeting date.

NOTES

**Agenda Sheet for City Council:****Committee:** **Date:** N/A**Committee Agenda type:****Date Rec'd**

7/23/2024

Clerk's File #

CPR 2012-0033

Cross Ref #**Project #****Council Meeting Date:** 08/12/2024**Submitting Dept**

MAYOR

Bid #**Contact Name/Phone**

ADAM 6779

Requisition #**Contact E-Mail**

AMCDANIEL@SPOKANECITY.ORG

Agenda Item Type

Boards and Commissions

Council Sponsor(s)**Agenda Item Name**

APPOINTMENT OF ANNA STAAL TO THE COMMUNITY, HOUSING, AND

Agenda Wording

Mayor Brown has appointed Anna Staal to the Community, Housing, and Human Services for a term of August 12, 2024 - August 12, 2028

Summary (Background)

The Community Housing and Human Services (CHHS) Board advises the City on preparing the required plans to conform with the requirements of the U.S. Department of Housing and Urban Development (HUD) and the Washington State Department of Commerce. The Board makes recommendations about funding priorities for housing programs and projects and social services utilizing federal, Washington State and City resources.

Lease? NO

Grant related? NO

Public Works? NO

Fiscal Impact

Approved in Current Year Budget? N/A

Total Cost

\$

Current Year Cost

\$

Subsequent Year(s) Cost

\$

Narrative**Amount****Budget Account**

Select

\$

#

Select

\$

#

Select

\$

#

Select

\$

#

\$

#

\$

#



Continuation of Wording, Summary, Approvals, and Distribution

Agenda Wording

Summary (Background)

Approvals		Additional Approvals	
<u>Dept Head</u>	JONES, GARRETT		
<u>Division Director</u>			
<u>Accounting Manager</u>			
<u>Legal</u>			
<u>For the Mayor</u>	JONES, GARRETT		

Distribution List

amcdaniel@spokanecity.org

Committee Agenda Sheet

Select Committee Name

Committee Date	August 12, 2024
Submitting Department	Mayor's Office
Contact Name	Adam McDaniel
Contact Email & Phone	amcdaniel@spokanecity.org 625-6779
Council Sponsor(s)	Please enter the name of the Council Sponsor(s)
Select Agenda Item Type	<input type="checkbox"/> Consent <input type="checkbox"/> Discussion Time Requested:
Agenda Item Name	Appointment of Anna Staal to the Community, Housing, and Human Services Board
Proposed Council Action	<input checked="" type="checkbox"/> Approval to proceed to Legislative Agenda <input type="checkbox"/> Information Only
Summary (Background) *use the Fiscal Impact box below for relevant financial information	<p>Mayor Brown has appointed Anna Staal to the Community, Housing, and Human Services for a term of August 12, 2024 – August 12, 2028</p> <p>The Community Housing and Human Services (CHHS) Board advises the City on preparing the required plans to conform with the requirements of the U.S. Department of Housing and Urban Development (HUD) and the Washington State Department of Commerce. The Board makes recommendations about funding priorities for housing programs and projects and social services utilizing federal, Washington State and City resources.</p> <p>The CHHS Board participates with the Spokane Continuum of Care in developing the goals and priorities for regional homeless plans. The Board also represents the diverse constituencies that make up Spokane's low- and moderate-income populations, to help guide Spokane's community, housing, and human services into the future.</p>
<p>Fiscal Impact</p> <p>Approved in current year budget? <input type="checkbox"/> Yes <input type="checkbox"/> No <input checked="" type="checkbox"/> N/A</p> <p>Total Cost: Click or tap here to enter text.</p> <p>Current year cost:</p> <p>Subsequent year(s) cost:</p> <p>Narrative: Please provide financial due diligence review, as applicable, such as number and type of positions, grant match requirements, summary type details (personnel, maintenance and supplies, capital, revenue), impact on rates, fees, or future shared revenue</p> <p>Funding Source <input type="checkbox"/> One-time <input type="checkbox"/> Recurring <input checked="" type="checkbox"/> N/A</p> <p>Specify funding source: Select Funding Source*</p> <p>Is this funding source sustainable for future years, months, etc? Click or tap here to enter text.</p> <p>Expense Occurrence <input type="checkbox"/> One-time <input type="checkbox"/> Recurring <input checked="" type="checkbox"/> N/A</p> <p>Other budget impacts: (revenue generating, match requirements, etc.)</p>	
Operations Impacts (If N/A, please give a brief description as to why)	
What impacts would the proposal have on historically excluded communities?	

N/A

How will data be collected, analyzed, and reported concerning the effect of the program/policy by racial, ethnic, gender identity, national origin, income level, disability, sexual orientation, or other existing disparities?

N/A

How will data be collected regarding the effectiveness of this program, policy or product to ensure it is the right solution?

N/A

Describe how this proposal aligns with current City Policies, including the Comprehensive Plan, Sustainability Action Plan, Capital Improvement Program, Neighborhood Master Plans, Council Resolutions, and others?

N/A

**Agenda Sheet for City Council:****Committee:** Finance & Administration **Date:** 07/22/2024**Committee Agenda type:** Consent**Date Rec'd**

7/24/2024

Clerk's File #

OPR 2024-0606

Cross Ref #**Project #****Council Meeting Date:** 08/12/2024**Submitting Dept**

CONTRACTS & PURCHASING

Bid #

WA ST CONTRACT

Contact Name/Phone

JASON 232-8841

Requisition #

VB

Contact E-Mail

JNECHANICKY@SPOKANECITY.ORG

Agenda Item Type

Purchase w/o Contract

Council Sponsor(s)

MCATHCART ZZAPPONE BWILKERSON

Agenda Item Name

5500 - VALUE BLANKET WITH POMP'S TIRE

Agenda Wording

Purchasing would like to contract with Pomp's Tire for the purchase of tires and tire related products utilizing the Washington State DES Contract. This will be a 2 year contract with the option of (3) 1 year extensions. \$800k annual

Summary (Background)

Pomp's has been the City's tire supplier for approximately two years and have proven themselves to be reliable and provide exceptional value. New contract is to coincide with Washington DES' current contract term.

Lease? NO Grant related? NO Public Works? NO

Fiscal Impact

Approved in Current Year Budget? YES

Total Cost \$ 800,000.00

Current Year Cost \$ 800,000.00

Subsequent Year(s) Cost \$ 800,000.00

Narrative

This contract utilizes the Washington DSC contract which meets City competitive purchasing requirements.

Amount**Budget Account**

Expense \$ 800,000.00

Varies by department

Select \$

#

Select \$

#

Select \$

#

\$

#

\$

#



Continuation of Wording, Summary, Approvals, and Distribution

Agenda Wording

Summary (Background)

Approvals

<u>Dept Head</u>		<u>Additional Approvals</u>	
	NECHANICKY, JASON	<u>PURCHASING</u>	NECHANICKY, JASON
<u>Division Director</u>	BOSTON, MATTHEW		
<u>Accounting Manager</u>	ALBIN-MOORE, ANGELA		
<u>Legal</u>	BEATTIE, LAUREN		
<u>For the Mayor</u>	PICCOLO, MIKE		

Distribution List

tprince@spokanecity.org

Council Briefing Paper

Finance & Administration Committee

Committee Date	July 22, 2024
Submitting Department	Purchasing & Contracts
Contact Name	Jason Nechanicky
Contact Email & Phone	509-232-8841
Council Sponsor(s)	Cathcart, Zappone, Wilkerson
Select Agenda Item Type	<input checked="" type="checkbox"/> Consent <input type="checkbox"/> Discussion Time Requested:
Agenda Item Name	5500 – Value Blanket Order with Pomp’s Tire
Proposed Council Action	<input checked="" type="checkbox"/> Approval to proceed to Legislative Agenda <input type="checkbox"/> Information Only
Summary (Background) *use the Fiscal Impact box below for relevant financial information	<p>Purchasing would like to contract with Pomp’s Tire for the purchase of tires and tire related products utilizing the Washington State DES Contract. This will be a two year contract with the option of three one year extensions for an annual expenditure not to exceed \$800,000.</p> <p>Pomp’s has been the City’s tire supplier for approximately two years and have proven themselves to be reliable and provide exceptional value. New contract is to coincide with Washington DES’ current contract term.</p>
<p>Fiscal Impact</p> <p>Approved in current year budget? <input checked="" type="checkbox"/> Yes <input type="checkbox"/> No <input type="checkbox"/> N/A</p> <p>Total Cost: <u>\$800,000</u></p> <p style="padding-left: 20px;">Current year cost: \$800,000</p> <p style="padding-left: 20px;">Subsequent year(s) cost: \$800,000</p> <p>Narrative: <u>This contract utilizes the Washington DSC contract which meets City competitive purchasing requirements.</u></p> <p>Funding Source <input type="checkbox"/> One-time <input checked="" type="checkbox"/> Recurring <input type="checkbox"/> N/A</p> <p>Specify funding source: Program revenue</p> <p>Is this funding source sustainable for future years, months, etc? Yes</p> <p>Expense Occurrence <input type="checkbox"/> One-time <input checked="" type="checkbox"/> Recurring <input type="checkbox"/> N/A</p> <p>Other budget impacts: (revenue generating, match requirements, etc.)</p>	
<p>Operations Impacts (If N/A, please give a brief description as to why)</p> <ul style="list-style-type: none"> • What impacts would the proposal have on historically excluded communities? None Identified • How will data be collected, analyzed, and reported concerning the effect of the program/policy by racial, ethnic, gender identity, national origin, income level, disability, sexual orientation, or other existing disparities? Data will not be collected. 	

- How will data be collected regarding the effectiveness of this program, policy, or product to ensure it is the right solution? Tire purchase and labor costs are collected to compare with other vendor options.
- Describe how this proposal aligns with current City Policies, including the Comprehensive Plan, Sustainability Action Plan, Capital Improvement Program, Neighborhood Master Plans, Council Resolutions, and others?

Council Subcommittee Review

- Please provide a summary of council subcommittee review. If not reviewed by a council subcommittee, please explain why not. Subcommittee for this topic does not exist.

**Agenda Sheet for City Council:****Committee:** Finance & Administration **Date:** 07/22/2024**Committee Agenda type:** Consent**Date Rec'd**

7/24/2024

Clerk's File #

OPR 2024-0607

Cross Ref #**Project #****Council Meeting Date:** 08/12/2024**Submitting Dept**

CONTRACTS & PURCHASING

Bid #

WA ST CONTRACT

Contact Name/Phone

JASON 232-8841

Requisition #

MASTER

Contact E-Mail

JNECHANICKY@SPOKANECITY.ORG

Agenda Item Type

Contract Item

Council Sponsor(s)

MCATHCART ZZAPPONE BWILKERSON

Agenda Item Name

5500 - MASTER SERVICE CONTRACT WITH POMP'S TIRE

Agenda Wording

Purchasing would like to contract with Pomp's Tire for tire services utilizing the Washington State DES Contract. This will be a five-year contract from July 1, 2024, to June 30, 2029.

Summary (Background)

Pomp's has provided tire service to the City for approximately two years and have proven themselves to be reliable and provide exceptional value. New service contract is to coincide with Washington DES' current contract term.

Lease? NO Grant related? NO Public Works? NO

Fiscal Impact

Approved in Current Year Budget? YES

Total Cost \$ 380,000.00

Current Year Cost \$ 380,000.00

Subsequent Year(s) Cost \$ 380,000.00

Narrative

This contract utilizes the Washington DSC contract which meets City competitive purchasing requirements.

Amount**Budget Account**

Expense \$ 380,000.00

Varies by department

Select \$

#

Select \$

#

Select \$

#

\$

#

\$

#

Council Briefing Paper

Finance & Administration Committee

Committee Date	July 22, 2024
Submitting Department	Purchasing & Contracts
Contact Name	Jason Nechanicky
Contact Email & Phone	509-232-8841
Council Sponsor(s)	Cathcart, Zappone, Wilkerson
Select Agenda Item Type	<input checked="" type="checkbox"/> Consent <input type="checkbox"/> Discussion Time Requested:
Agenda Item Name	5500 – Master Service Contract with Pomp’s Tire
Proposed Council Action	<input checked="" type="checkbox"/> Approval to proceed to Legislative Agenda <input type="checkbox"/> Information Only
Summary (Background) *use the Fiscal Impact box below for relevant financial information	<p>Purchasing would like to contract with Pomp’s Tire for tire services utilizing the Washington State DES Contract. This will be a five-year contract from July 1, 2024, to June 30, 2029. for an annual expenditure not to exceed \$380,000.</p> <p>Pomp’s has provided tire service to the City for approximately two years and have proven themselves to be reliable and provide exceptional value. New service contract is to coincide with Washington DES’ current contract term.</p>
<p>Fiscal Impact</p> <p>Approved in current year budget? <input checked="" type="checkbox"/> Yes <input type="checkbox"/> No <input type="checkbox"/> N/A</p> <p>Total Cost: <u>\$380,000</u></p> <p style="padding-left: 20px;">Current year cost: \$380,000</p> <p style="padding-left: 20px;">Subsequent year(s) cost: \$380,000</p> <p>Narrative: <u>This contract utilizes the Washington DSC contract which meets City competitive purchasing requirements.</u></p> <p>Funding Source <input type="checkbox"/> One-time <input checked="" type="checkbox"/> Recurring <input type="checkbox"/> N/A</p> <p>Specify funding source: Program revenue</p> <p>Is this funding source sustainable for future years, months, etc? Yes</p> <p>Expense Occurrence <input type="checkbox"/> One-time <input checked="" type="checkbox"/> Recurring <input type="checkbox"/> N/A</p> <p>Other budget impacts: (revenue generating, match requirements, etc.)</p>	
<p>Operations Impacts (If N/A, please give a brief description as to why)</p> <ul style="list-style-type: none"> • What impacts would the proposal have on historically excluded communities? None Identified • How will data be collected, analyzed, and reported concerning the effect of the program/policy by racial, ethnic, gender identity, national origin, income level, disability, sexual orientation, or other existing disparities? Data will not be collected. • How will data be collected regarding the effectiveness of this program, policy, or product to ensure it is the right solution? Tire purchase and labor costs are collected to compare with other vendor options. 	

- Describe how this proposal aligns with current City Policies, including the Comprehensive Plan, Sustainability Action Plan, Capital Improvement Program, Neighborhood Master Plans, Council Resolutions, and others?

Council Subcommittee Review

- Please provide a summary of council subcommittee review. If not reviewed by a council subcommittee, please explain why not. Subcommittee for this topic does not exist.



City of Spokane
PERSONAL SERVICE AGREEMENT
Title: **MISCELLANEOUS TIRE SERVICES**

This Agreement is made and entered into by and between the **CITY OF SPOKANE** as (“City”), a Washington municipal corporation, and **POMP TIRE SERVICES**, whose address is 1505 North Hough Street, Spokane, Washington 99212 as (“Company”), individually hereafter referenced as a “party”, and together as the “parties”.

The parties agree as follows:

1. PERFORMANCE.

The Company shall provide Miscellaneous Tire Services. Company was selected through Washington State Contract No. 24623. In the event of a conflict between these documents and this City Contract, the terms of this contract will control.

2. TERM OF AGREEMENT.

The term of this Agreement begins on July 1, 2024, and shall run through June 30, 2029, unless amended by written agreement or terminated earlier under the provisions of this Agreement.

3. COMPENSATION / PAYMENT.

Total annual compensation for Company’s services under this Agreement shall not exceed **THREE HUNDRED THOUSAND AND NO/100 DOLLARS (\$300,000.00)**, plus applicable tax, per year, for everything furnished and done under this Agreement. This is an optional use contract. Services by the Company are provided on an as-needed basis upon request in accordance with the terms of the Contract documents. Only the services requested, received and accepted will be paid for by the City.

The Company shall submit its applications for payment to for payment to the requesting department. **Payment will be made via direct deposit/ACH** within thirty (30) days after receipt of the Company’s application except as provided by state law. If the City objects to all or any portion of the invoice, it shall notify the Company and reserves the right to only pay that portion of the invoice not in dispute. In that event, the parties shall immediately make every effort to settle the disputed amount.

4. TAXES, FEES AND LICENSES.

A. Company shall pay and maintain in current status, all necessary licenses, fees, assessments, permit charges, etc. necessary to conduct the work included under this Agreement. It is the Company’s sole responsibility to monitor and determine changes or the enactment of any subsequent requirements for said fees, assessments, or changes and to immediately comply.

- B. The cost of any permits, licenses, fees, etc. arising as a result of the projects included in this Agreement shall be included in the project budgets.

5. CITY OF SPOKANE BUSINESS LICENSE.

Section 8.01.070 of the Spokane Municipal Code states that no person may engage in business with the City without first having obtained a valid annual business registration. The Company shall be responsible for contacting the State of Washington Business License Services at www.dor.wa.gov or 360-705-6741 to obtain a business registration. If the Company does not believe it is required to obtain a business registration, it may contact the City's Taxes and Licenses Division at (509) 625-6070 to request an exemption status determination.

6. SOCIAL EQUITY REQUIREMENTS / NON-DISCRIMINATION.

No individual shall be excluded from participation in, denied the benefit of, subjected to discrimination under, or denied employment in the administration of or in connection with this Agreement because of age, sex, race, color, religion, creed, marital status, familial status, sexual orientation including gender expression or gender identity, national origin, honorably discharged veteran or military status, the presence of any sensory, mental or physical disability, or use of a service animal by a person with disabilities. The Company agrees to comply with, and to require that all subcontractors comply with, federal, state and local nondiscrimination laws, including but not limited to: the Civil Rights Act of 1964, the Rehabilitation Act of 1973, the Age Discrimination in Employment Act, and the American's With Disabilities Act, to the extent those laws are applicable.

7. INDEMNIFICATION.

The Company shall defend, indemnify, and hold the City and its officers and employees harmless from all claims, demands, or suits at law or equity asserted by third parties for bodily injury (including death) and/or property damage which arise from the Company's negligence or willful misconduct under this Agreement, including attorneys' fees and litigation costs; provided that nothing herein shall require a Company to indemnify the City against and hold harmless the City from claims, demands or suits based solely upon the negligence of the City, its agents, officers, and employees. If a claim or suit is caused by or results from the concurrent negligence of the Company's agents or employees and the City, its agents, officers and employees, this indemnity provision shall be valid and enforceable to the extent of the negligence of the Company, its agents or employees. The Company specifically assumes liability and agrees to defend, indemnify, and hold the City harmless for actions brought by the Company's own employees against the City and, solely for the purpose of this indemnification and defense, the Company specifically waives any immunity under the Washington State industrial insurance law, or Title 51 RCW. The Company recognizes that this waiver was specifically entered into pursuant to the provisions of RCW 4.24.115 and was the subject of mutual negotiation. The indemnity and agreement to defend and hold the City harmless provided for in this section shall survive any termination or expiration of this agreement.

8. INSURANCE.

During the period of the Agreement, the Company shall maintain in force at its own expense, each insurance noted below with companies or through sources approved by the State Insurance Commissioner pursuant to RCW 48:

- A. **Worker's Compensation Insurance** in compliance with RCW 51.12.020, which requires subject employers to provide workers' compensation coverage for all their subject workers and Employer's Liability Insurance in the amount of \$1,000,000;

B. **General Liability Insurance** on an occurrence basis, with a combined single limit of not less than \$1,000,000 each occurrence for bodily injury and property damage. It shall include contractual liability coverage for the indemnity provided under this agreement. It shall provide that the City, its officers and employees are additional insureds but only with respect to the Company's services to be provided under this Agreement;

i. Acceptable **supplementary Umbrella insurance** coverage combined with Company's General Liability insurance policy must be a minimum of \$1,000,000, in order to meet the insurance coverage limits required in this Agreement; and

C. **Automobile Liability Insurance** with a combined single limit, or the equivalent of not less than \$1,000,000 each accident for bodily injury and property damage, including coverage for owned, hired and non-owned vehicles.

There shall be no cancellation, material change, reduction of limits or intent not to renew the insurance coverage(s) without forty-five (45) days written notice from the Company or its insurer(s) to the City. As evidence of the insurance coverage(s) required by this Agreement, the Company shall furnish acceptable Certificates of Insurance (COI) to the City at the time it returns this signed Agreement. The certificate shall specify the City of Spokane as "Additional Insured" specifically for Company's services under this Agreement, as well as all of the parties who are additional insureds, and include applicable policy endorsements, the forty-five (45) day cancellation clause, and the deduction or retention level. The Company shall be financially responsible for all pertinent deductibles, self-insured retentions, and/or self-insurance.

10. DEBARMENT AND SUSPENSION.

The Company has provided its certification that it is in compliance with and shall not contract with individuals or organizations which are debarred, suspended, or otherwise excluded from or ineligible from participation in Federal Assistance Programs under Executive Order 12549 and "Debarment and Suspension", codified at 29 CFR part 98.

11. AUDIT.

The Company and its sub-contractor shall maintain for a minimum of three (3) years following final payment all records related to its performance of the Agreement. The Company and its sub-contractors shall provide access to authorized City representatives, at reasonable times and in a reasonable manner to inspect and copy any such record. In the event of conflict between this provision and related auditing provisions required under federal law applicable to the Agreement, the federal law shall prevail.

12. ASSIGNMENT AND SUBCONTRACTING.

The Company shall not assign or subcontract its obligations under this Agreement without the City's written consent, which may be granted or withheld in the City's sole discretion. Any subcontract made by the Company shall incorporate by reference this Agreement, except as otherwise provided. The Company shall ensure that all subcontractors comply with the obligations and requirements of the subcontract. The City's consent to any assignment or subcontract does not release the Company from liability or any obligation within this Agreement, whether before or after City consent, assignment or subcontract.

13. TERMINATION.

Either party may terminate this Agreement, with or without cause, by sixty (60) days written notice to the other party. In the event of such termination, the City shall pay the Company for all work previously authorized and performed prior to the termination date.

14. STANDARD OF PERFORMANCE.

The standard of performance applicable to Company's services will be the degree of skill and diligence normally employed by professional Companies performing the same or similar services at the time the services under this Agreement are performed.

15. OWNERSHIP AND USE OF RECORDS AND DOCUMENTS.

Original documents, drawings, designs, reports, or any other records developed or created under this Agreement shall belong to and become the property of the City. All records submitted by the City to the Company shall be safeguarded by the Company. The Company shall make such data, documents and files available to the City upon the City's request. If the City's use of the Company's records or data is not related to this project, it shall be without liability or legal exposure to the Company.

Under Washington State Law (reference RCW Chapter 42.56, the *Public Records Act* [PRA]) all materials received or created by the City of Spokane are **public records** and are available to the public for viewing via the City Clerk's Records (online) or a valid Public Records Request (PRR).

16. ANTI KICK-BACK.

No officer or employee of the City of Spokane, having the power or duty to perform an official act or action related to this Agreement shall have or acquire any interest in the Agreement, or have solicited, accepted or granted a present or future gift, favor, service or other thing of value from or to any person involved in this Agreement.

17. MISCELLANEOUS PROVISIONS.

- A. **Amendments/Modifications:** This Agreement may be modified by the City in writing when necessary, and no modification or Amendment of this Agreement shall be effective unless signed by an authorized representative of each of the parties hereto.
- B. The Company, at no expense to the City, shall comply with all laws of the United States and Washington, the Charter and ordinances of the City of Spokane; and rules, regulations, orders and directives of their administrative agencies and officers. Without limiting the generality of this paragraph, the Company shall comply with the requirements of this Section.
- C. This Agreement shall be construed and interpreted under the laws of Washington. The venue of any action brought shall be in a court of competent jurisdiction, located in Spokane County, Washington.
- D. **Captions:** The titles of sections or subsections are for convenience only and do not define or limit the contents.
- E. **Severability:** If any term or provision is determined by a court of competent jurisdiction to be invalid or unenforceable, the remainder of this Agreement shall not be affected, and each term and provision shall be valid and enforceable to the fullest extent permitted by law.
- F. **Waiver:** No covenant, term or condition or the breach shall be deemed waived, except by written consent of the party against whom the waiver is claimed, and any waiver of the breach of any covenant, term or condition shall not be deemed a waiver of any preceding or succeeding breach of the same or any other covenant, term of condition. Neither the acceptance by the City of any performance by the Company after the time the same shall have become due nor payment to the Company for any portion of the Work shall constitute a waiver by the City of the breach or default of any covenant, term or condition unless otherwise expressly agreed to by the City in writing.

- G. **Entire Agreement:** This document along with any exhibits and all attachments, and subsequently issued addenda, comprises the entire agreement between the City and the Company. If conflict occurs between Agreement documents and applicable laws, codes, ordinances or regulations, the most stringent or legally binding requirement shall govern and be considered a part of this Agreement to afford the City the maximum benefits.
- H. **No personal liability:** No officer, agent or authorized employee of the City shall be personally responsible for any liability arising under this Agreement, whether expressed or implied, nor for any statement or representation made or in any connection with this Agreement.

IN WITNESS WHEREOF, in consideration of the terms, conditions and covenants contained, or attached and incorporated and made a part, the parties have executed this Agreement by having legally-binding representatives affix their signatures below.

POMP TIRE SERVICES

CITY OF SPOKANE

By _____
Signature Date

By _____
Signature Date

Type or Print Name

Type or Print Name

Title

Title

Attest:

Approved as to form:

City Clerk

Assistant City Attorney

Attachments that are part of this Agreement:
Exhibit A – Certificate Regarding debarment
24-125

EXHIBIT A

**CERTIFICATION REGARDING DEBARMENT, SUSPENSION,
INELIGIBILITY AND VOLUNTARY EXCLUSION**

1. The undersigned (i.e., signatory for the Subrecipient / Contractor / Consultant) certifies, to the best of its knowledge and belief, that it and its principals:
 - a. Are not presently debarred, suspended, proposed for debarment, declared ineligible, or voluntarily excluded from covered transactions by any federal department or agency;
 - b. Have not within a three-year period preceding this contract been convicted or had a civil judgment rendered against them for commission of fraud or a criminal offense in connection with obtaining, attempting to obtain, or performing a public (federal, state, or local) transaction or contract under a public transaction; violation of federal or state antitrust statutes or commission of embezzlement, theft, forgery, bribery, falsification or destruction of records, making false statements, tax evasion, receiving stolen property, making false claims, or obstruction of justice;
 - c. Are not presently indicted or otherwise criminally or civilly charged by a government entity (federal, state, or local) with commission of any of the offenses enumerated in paragraph (1)(b) of this certification; and,
 - d. Have not within a three-year period preceding this contract had one or more public transactions (federal, state, or local) terminated for cause or default.

2. The undersigned agrees by signing this contract that it shall not knowingly enter into any lower tier covered transaction with a person who is debarred, suspended, declared ineligible, or voluntarily excluded from participation in this covered transaction.

3. The undersigned further agrees by signing this contract that it will include the following clause, without modification, in all lower tier covered transactions and in all solicitations for lower tier covered transactions:

Certification Regarding Debarment, Suspension, Ineligibility and Voluntary Exclusion – Lower Tier Covered Transactions

 1. The lower tier contractor certifies, by signing this contract that neither it nor its principals is presently debarred, suspended, proposed for debarment, declared ineligible, or voluntarily excluded from participation in this transaction by any federal department or agency.
 2. Where the lower tier contractor is unable to certify to any of the statements in this contract, such contractor shall attach an explanation to this contract.

4. I understand that a false statement of this certification may be grounds for termination of the contract.

<hr/> Name of Subrecipient / Contractor / Consultant (Type or Print)	<hr/> Program Title (Type or Print)
<hr/> Name of Certifying Official (Type or Print)	<hr/> Signature
<hr/> Title of Certifying Official (Type or Print)	<hr/> Date (Type or Print)



CERTIFICATE OF LIABILITY INSURANCE

DATE (MM/DD/YYYY)
07/08/2024

THIS CERTIFICATE IS ISSUED AS A MATTER OF INFORMATION ONLY AND CONFERS NO RIGHTS UPON THE CERTIFICATE HOLDER. THIS CERTIFICATE DOES NOT AFFIRMATIVELY OR NEGATIVELY AMEND, EXTEND OR ALTER THE COVERAGE AFFORDED BY THE POLICIES BELOW. THIS CERTIFICATE OF INSURANCE DOES NOT CONSTITUTE A CONTRACT BETWEEN THE ISSUING INSURER(S), AUTHORIZED REPRESENTATIVE OR PRODUCER, AND THE CERTIFICATE HOLDER.

IMPORTANT: If the certificate holder is an ADDITIONAL INSURED, the policy(ies) must have ADDITIONAL INSURED provisions or be endorsed. If SUBROGATION IS WAIVED, subject to the terms and conditions of the policy, certain policies may require an endorsement. A statement on this certificate does not confer rights to the certificate holder in lieu of such endorsement(s).

PRODUCER
FEDERATED MUTUAL INSURANCE COMPANY
HOME OFFICE: P.O. BOX 328
OWATONNA, MN 55060

CONTACT NAME: CLIENT CONTACT CENTER
PHONE (A/C, No, Ext): 888-333-4949 FAX (A/C, No): 507-446-4664
E-MAIL ADDRESS: CLIENTCONTACTCENTER@FEDINS.COM

INSURED
POMP'S TIRE SERVICE INC
1123 CEDAR ST
GREEN BAY, WI 54301-4703

302-609-3

INSURERS AFFORDING COVERAGE	NAIC #
INSURER A: FEDERATED MUTUAL INSURANCE COMPANY	13935
INSURER B:	
INSURER C:	
INSURER D:	
INSURER E:	
INSURER F:	

COVERAGES

CERTIFICATE NUMBER: 2008

REVISION NUMBER: 1

THIS IS TO CERTIFY THAT THE POLICIES OF INSURANCE LISTED BELOW HAVE BEEN ISSUED TO THE INSURED NAMED ABOVE FOR THE POLICY PERIOD INDICATED. NOTWITHSTANDING ANY REQUIREMENT, TERM OR CONDITION OF ANY CONTRACT OR OTHER DOCUMENT WITH RESPECT TO WHICH THIS CERTIFICATE MAY BE ISSUED OR MAY PERTAIN, THE INSURANCE AFFORDED BY THE POLICIES DESCRIBED HEREIN IS SUBJECT TO ALL THE TERMS, EXCLUSIONS AND CONDITIONS OF SUCH POLICIES. LIMITS SHOWN MAY HAVE BEEN REDUCED BY PAID CLAIMS.

INSR	TYPE OF INSURANCE	ADDL	SUBR	POLICY NUMBER	POLICY EFF (MM/DD/YYYY)	POLICY EXP (MM/DD/YYYY)	LIMITS
A	<input checked="" type="checkbox"/> COMMERCIAL GENERAL LIABILITY <input type="checkbox"/> CLAIMS-MADE <input checked="" type="checkbox"/> OCCUR GEN'L AGGREGATE LIMIT APPLIES PER: <input checked="" type="checkbox"/> POLICY <input type="checkbox"/> PROJECT <input type="checkbox"/> LOC OTHER:	Y	N	0748868	09/01/2023	09/01/2024	EACH OCCURRENCE \$1,000,000 DAMAGE TO RENTED PREMISES (Ea occurrence) \$100,000 MED EXP (Any one person) \$10,000 PERSONAL & ADV INJURY \$1,000,000 GENERAL AGGREGATE \$2,000,000 PRODUCTS & COMP/OP AGG \$2,000,000
A	AUTOMOBILE LIABILITY <input checked="" type="checkbox"/> ANY AUTO <input type="checkbox"/> OWNED AUTOS ONLY <input type="checkbox"/> SCHEDULED AUTOS <input type="checkbox"/> HIRED AUTOS ONLY <input type="checkbox"/> NON-OWNED AUTOS ONLY	N	N	0748868	09/01/2023	09/01/2024	COMBINED SINGLE LIMIT (Ea accident) \$1,000,000 BODILY INJURY (Per Person) BODILY INJURY (Per Accident) PROPERTY DAMAGE (Per Accident)
A	<input checked="" type="checkbox"/> UMBRELLA LIAB <input checked="" type="checkbox"/> OCCUR <input type="checkbox"/> EXCESS LIAB <input type="checkbox"/> CLAIMS-MADE DED RETENTION	N	N	0748870	09/01/2023	09/01/2024	EACH OCCURRENCE \$10,000,000 AGGREGATE \$10,000,000
	WORKERS COMPENSATION AND EMPLOYERS' LIABILITY ANY PROPRIETOR/PARTNER/ EXECUTIVE OFFICER/MEMBER EXCLUDED? (Mandatory in NH) If yes, describe under DESCRIPTION OF OPERATIONS below	Y/N	N/A				PER STATUTE OTHER E.L EACH ACCIDENT E.L DISEASE EA EMPLOYEE E.L DISEASE - POLICY LIMIT

DESCRIPTION OF OPERATIONS / LOCATIONS / VEHICLES (ACORD 101, Additional Remarks Schedule, may be attached if more space is required)

ADDITIONAL INSURED INCLUDES: CITY OF SPOKANE, ITS OFFICERS AND EMPLOYEES

THE CERTIFICATE HOLDER IS AN ADDITIONAL INSURED SUBJECT TO THE CONDITIONS OF THE ADDITIONAL INSURED - OWNERS, LESSEES OR CONTRACTORS - AUTOMATIC STATUS WHEN REQUIRED IN CONSTRUCTION AGREEMENT WITH YOU ENDORSEMENT FOR GENERAL LIABILITY.

CERTIFICATE HOLDER

302-609-3
CITY OF SPOKANE
808 W SPOKANE FALLS BLVD
SPOKANE, WA 99201-3333

2008 1

CANCELLATION

SHOULD ANY OF THE ABOVE DESCRIBED POLICIES BE CANCELLED BEFORE THE EXPIRATION DATE THEREOF, NOTICE WILL BE DELIVERED IN ACCORDANCE WITH THE POLICY PROVISIONS.

AUTHORIZED REPRESENTATIVE

THIS ENDORSEMENT CHANGES THE POLICY. PLEASE READ IT CAREFULLY.

**ADDITIONAL INSURED - OWNERS, LESSEES OR
CONTRACTORS - AUTOMATIC STATUS WHEN
REQUIRED IN A WRITTEN CONSTRUCTION
AGREEMENT WITH YOU**

This endorsement modifies insurance provided under the following:

COMMERCIAL GENERAL LIABILITY COVERAGE PART

- A. Section II - Who Is An Insured** is amended to include as an additional insured any person or organization for whom you are performing operations when you and such person or organization have agreed in writing in a contract or agreement that such person or organization be added as an additional insured on your policy. Such person or organization is an additional insured only with respect to liability for "bodily injury", "property damage" or "personal and advertising injury" caused, in whole or in part, by:
1. Your acts or omissions; or
 2. The acts or omissions of those acting on your behalf;
- in the performance of your ongoing operations for the additional insured.
- However, the insurance afforded to such additional insured:
1. Only applies to the extent permitted by law; and
 2. Will not be broader than that which you are required by the contract or agreement to provide for such additional insured.
- A person's or organization's status as an additional insured under this endorsement ends when your operations for that additional insured are completed.
- B.** With respect to the insurance afforded to these additional insureds, the following additional exclusions apply:
- This insurance does not apply to:
1. "Bodily injury", "property damage" or "personal and advertising injury" arising out of the rendering of, or the failure to render, any professional architectural, engineering or surveying services, including:
 - a. The preparing, approving, or failing to prepare or approve, maps, shop drawings, opinions, reports, surveys, field orders, change orders or drawings and specifications; or
 - b. Supervisory, inspection, architectural or engineering activities.
- This exclusion applies even if the claims against any insured allege negligence or other wrongdoing in the supervision, hiring, employment, training or monitoring of others by that insured, if the "occurrence" which caused the "bodily injury" or "property damage", or the offense which caused the "personal and advertising injury", involved the rendering of or the failure to render any professional architectural, engineering or surveying services.

2. "Bodily injury" or "property damage" occurring after:
- a. All work, including materials, parts or equipment furnished in connection with such work, on the project (other than service, maintenance or repairs) to be performed by or on behalf of the additional insured(s) at the location of the covered operations has been completed; or
 - b. That portion of "your work" out of which the injury or damage arises has been put to its intended use by any person or organization other than another contractor or subcontractor engaged in performing operations for a principal as a part of the same project.

- C. With respect to the insurance afforded to these additional insureds, the following is added to **Section III - Limits Of Insurance:**

The most we will pay on behalf of the additional insured is the amount of insurance:

- 1. Required by the contract or agreement you have entered into with the additional insured; or
- 2. Available under the applicable limits of insurance;

whichever is less.

This endorsement shall not increase the applicable limits of insurance.



STATE OF WASHINGTON

BUSINESS LICENSE

Profit Corporation

POMP'S TIRE SERVICE, INC.
1505 N HOUGH ST
SPOKANE WA 99212-7007

UNEMPLOYMENT INSURANCE - ACTIVE
TAX REGISTRATION - ACTIVE

INDUSTRIAL INSURANCE - ACTIVE

Issue Date: Apr 26, 2024
Unified Business ID #: 604921017
Business ID #: 001
Location: 0001
Expires: May 31, 2025

CITY/COUNTY ENDORSEMENTS:

SPOKANE GENERAL BUSINESS - ACTIVE

LICENSING RESTRICTIONS:

Not licensed to hire minors without a Minor Work Permit.

REGISTERED TRADE NAMES:

POMP'S TIRE SERVICE, INC.

This document lists the registrations, endorsements, and licenses authorized for the business named above. By accepting this document, the licensee certifies the information on the application was complete, true, and accurate to the best of his or her knowledge, and that business will be conducted in compliance with all applicable Washington state, county, and city regulations.

Director, Department of Revenue

STATE OF WASHINGTON

UBI: 604921017 001 0001

Expires: May 31, 2025

POMP'S TIRE SERVICE, INC.
1505 N HOUGH ST
SPOKANE WA 99212-7007

UNEMPLOYMENT INSURANCE -
ACTIVE
INDUSTRIAL INSURANCE - ACTIVE
TAX REGISTRATION - ACTIVE
SPOKANE GENERAL BUSINESS -
ACTIVE



Agenda Sheet for City Council:

Committee: Finance & Administration **Date:** 07/22/2024

Committee Agenda type: Consent

Date Rec'd 7/24/2024

Clerk's File # OPR 2023-0686

Cross Ref #

Project #

Council Meeting Date: 08/12/2024

Submitting Dept	SOLID WASTE DISPOSAL	Bid #	IPWQ 5891-23
------------------------	----------------------	--------------	--------------

Contact Name/Phone	DAVID PAINE 625-6878	Requisition #	CR 26489
---------------------------	----------------------	----------------------	----------

Contact E-Mail	DPAINE@SPOKANECITY.ORG		
-----------------------	------------------------	--	--

Agenda Item Type	Contract Item		
-------------------------	---------------	--	--

Council Sponsor(s)	BWILKERSON JBINGLE KKLITZKE		
---------------------------	-----------------------------	--	--

Agenda Item Name	4490 CONTRACT AMENDMENT FOR CONVEYOR BELT SERVICES		
-------------------------	--	--	--

Agenda Wording

Contract amendment with Applied Industrial Technologies (Spokane, WA) for conveyor belt services at the Waste to Energy Facility from 7/1/23-6/30/25. An additional \$150,000.00 is needed for a contract total of \$360,000.00, plus tax.

Summary (Background)

The Waste to Energy Facility operates continuously, incinerating refuse. The resulting ash is transported in the facility by conveyors. In the event of a failure, replacement belts need to be readily available. The current two-year contract for the purchase and installation of these conveyor belts has exhausted the \$210,000.00 planned expense due to unplanned but necessary repairs to the ash system. Additional funding is needed for the remainder of the contract to facilitate additional repairs.

Lease? NO Grant related? NO Public Works? YES

Fiscal Impact

Approved in Current Year Budget? YES

Total Cost	\$ 360,000.00
------------	---------------

Current Year Cost	\$ 150,000.00
-------------------	---------------

Subsequent Year(s) Cost	\$ 0
-------------------------	------

Narrative

This is an unplanned repair and maintenance expense. The additional funding needed will be moved from other planned projects currently in the budget through cancellation or revision of work scopes.

Amount

Budget Account

Expense	\$ 150,000.00	# 4490-44100-37148-54803-34002
Select	\$	#
Select	\$	#
Select	\$	#
	\$	#
	\$	#



Continuation of Wording, Summary, Approvals, and Distribution

Agenda Wording

Summary (Background)

Approvals

<u>Dept Head</u>		<u>Additional Approvals</u>	
	AVERYT, CHRIS	<u>PURCHASING</u>	PRINCE, THEA
<u>Division Director</u>	FEIST, MARLENE		
<u>Accounting Manager</u>	ALBIN-MOORE, ANGELA		
<u>Legal</u>	BEATTIE, LAUREN		
<u>For the Mayor</u>	JONES, GARRETT		

Distribution List

Jason Vasquez, jvasquez@applied.com	mdorgan@spokanecity.org
jsalstrom@spokanecity.org	tprince@spokanecity.org
rrinderle@spokanecity.org	

Committee Agenda Sheet

Finance & Administration Committee

Committee Date	July 22, 2024
Submitting Department	Solid Waste Disposal
Contact Name	David Paine
Contact Email & Phone	dpaine@spokanecity.org , 509-625-6878
Council Sponsor(s)	Wilkerson, Bingle, Klitzke
Select Agenda Item Type	<input checked="" type="checkbox"/> Consent <input type="checkbox"/> Discussion Time Requested:
Agenda Item Name	Contract amendment with cost for the as-needed purchase and installation of conveyor feed belts at the Waste to Energy Facility
Proposed Council Action	<input checked="" type="checkbox"/> Approval to proceed to Legislative Agenda <input type="checkbox"/> Information Only
Summary (Background) *use the Fiscal Impact box below for relevant financial information	<p>The Waste to Energy Facility operates continuously throughout the year incinerating refuse. The refuse and resulting ash is carried throughout the facility utilizing conveyors. In the event of a conveyor belt failure, there needs to be an immediate response to repair or replace the belt to minimize down time. Unfortunately, there are very long lead times for the purchase of replacement belts, so they need to be purchased and available prior to a failure.</p> <p>On May 17, 2023 bidding closed on IPWQ 5891-23 for the as-needed purchase and installation of these conveyor belts and Applied Industrial Technologies, of Spokane, WA was the only respondent. The initial contract award was for two years from July 1, 2023, through June 30, 2025 with an anticipated expense not to exceed \$210,000.00 plus tax. Unfortunately, as a result of unplanned but necessary repairs to the Ash System the funds on this contract have been exhausted. There is an immediate need for other repair parts to maintain, safely operate, and sustain environmental compliance while operating the system. If unable to expedite the addition of funds, the system may fail and result in the closure of operations until such time as we are able to facilitate the necessary repairs. An additional \$150,000.00 plus tax is being requested for a total two-year contract cost of \$360,000.00 plus tax.</p>
Fiscal Impact	
Approved in current year budget? <input checked="" type="checkbox"/> Yes <input type="checkbox"/> No <input type="checkbox"/> N/A Total Cost: <u>\$150,000.00 additional. Total two-year cost of \$360,000.00</u> Current year cost: \$150,000.00 Subsequent year(s) cost: 0	
Narrative: <u>This is an unplanned repair and maintenance expense. The additional funding needed will be moved from other planned projects currently in the budget through cancellations or revision of work scopes.</u>	
Funding Source <input type="checkbox"/> One-time <input checked="" type="checkbox"/> Recurring <input type="checkbox"/> N/A Specify funding source: Program revenue Is this funding source sustainable for future years, months, etc? Yes	
Expense Occurrence <input checked="" type="checkbox"/> One-time <input type="checkbox"/> Recurring <input type="checkbox"/> N/A Other budget impacts: (revenue generating, match requirements, etc.)	

Operations Impacts (If N/A, please give a brief description as to why)

- What impacts would the proposal have on historically excluded communities?
Public works services and projects are designed to serve all citizens and businesses. We strive to offer a consistent level of service to all, to distribute public investment throughout the community and to respond to gaps in services identified in various City plans.
- How will data be collected, analyzed, and reported concerning the effect of the program/policy by racial, ethnic, gender identity, national origin, income level, disability, sexual orientation, or other existing disparities?
N/A
- How will data be collected regarding the effectiveness of this program, policy, or product to ensure it is the right solution?
Public Works follows the City's established procurement and public works bidding regulations and policies to bring items forward, and then uses contract management best practices to ensure desired outcomes and regulatory compliance.
- Describe how this proposal aligns with current City Policies, including the Comprehensive Plan, Sustainability Action Plan, Capital Improvement Program, Neighborhood Master Plans, Council Resolutions, and others?
This work is consistent with annual budget strategies to limit costs and approved projects in the 6-year CIP.

Council Subcommittee Review

- Please provide a summary of council subcommittee review. If not reviewed by a council subcommittee, please explain why not.

Not applicable



CITY OF SPOKANE
CONTRACT AMENDMENT
Title: CONVEYOR BELT SERVICES

This Contract Amendment is made and entered into by and between the **CITY OF SPOKANE** as (“City”), a Washington municipal corporation, and **APPLIED INDUSTRIAL TECHNOLOGIES, INC.**, whose address is 301 North Fancher Road, Spokane, Washington, 99212 as (“Contractor”), individually hereafter referenced as a “Party”, and together as the “Parties”.

WHEREAS, the parties entered into a Contract wherein the Contractor agreed to provide Conveyor Belt Purchase, Installation and Repair at the Waste to Energy Facility; and

WHEREAS, additional funds are needed due to unanticipated belt failures, thus the original Contract needs to be formally Amended by this written document; and

NOW, THEREFORE, in consideration of these terms, the parties mutually agree as follows:

1. CONTRACT DOCUMENTS.

The Contract, dated August 16, 2023 and September 7, 2023, any previous amendments, addendums and / or extensions / renewals thereto, are incorporated by reference into this document as though written in full and shall remain in full force and effect except as provided herein.

2. EFFECTIVE DATE.

This Contract Amendment shall become effective on July 1, 2024, and shall end June 30, 2025.

3. COMPENSATION.

The City shall pay an additional amount not to exceed **ONE HUNDRED FIFTY THOUSAND AND NO/100 DOLLARS (\$150,000.00)**, plus applicable sales tax, for everything furnished and done under this Contract Amendment. This is the maximum amount to be paid under this Amendment, and shall not be exceeded without the prior written authorization of the City, memorialized with the same formality as the original Contract and this document.

IN WITNESS WHEREOF, in consideration of the terms, conditions and covenants contained, or attached and incorporated and made a part, the parties have executed this Contract Amendment by having legally-binding representatives affix their signatures below.

APPLIED INDUSTRIAL TECHNOLOGIES, INC.

CITY OF SPOKANE

By _____
Signature Date

By _____
Signature Date

Type or Print Name

Type or Print Name

Title

Title

Attest:

Approved as to form:

City Clerk

Assistant City Attorney



CERTIFICATE OF LIABILITY INSURANCE

APPLIIND2

DATE (MM/DD/YYYY)
5/28/202

THIS CERTIFICATE IS ISSUED AS A MATTER OF INFORMATION ONLY AND CONFERS NO RIGHTS UPON THE CERTIFICATE HOLDER. CERTIFICATE DOES NOT AFFIRMATIVELY OR NEGATIVELY AMEND, EXTEND OR ALTER THE COVERAGE AFFORDED BY THE POLICY BELOW. THIS CERTIFICATE OF INSURANCE DOES NOT CONSTITUTE A CONTRACT BETWEEN THE ISSUING INSURER(S), AUTHOR REPRESENTATIVE OR PRODUCER, AND THE CERTIFICATE HOLDER.



IMPORTANT: If the certificate holder is an ADDITIONAL INSURED, the policy(ies) must have ADDITIONAL INSURED provisions or be endorsed. If SUBROGATION IS WAIVED, subject to the terms and conditions of the policy, certain policies may require an endorsement. A statement on this certificate does not confer rights to the certificate holder in lieu of such endorsement(s).

PRODUCER Commercial Lines - (404) 923-3700 USI Insurance Services LLC 1 Concourse Parkway NE, Suite 700 Atlanta, GA 30328	RECEIVED JUN 05 2024 CITY CLERK'S OFFICE	CONTACT NAME: Christina McMahan PHONE (A/C No. Ext): 470-377-8722 E-MAIL ADDRESS: christina.mcmahan@usi.com	FAX (A/C No.): 610-537-1929
		INSURER(S) AFFORDING COVERAGE	
INSURED Applied Industrial Technologies, Inc. One Applied Plaza Euclid Avenue at 36th Street Cleveland OH 44115		INSURER A: ACE American Insurance Company	22667
		INSURER B: ACE Property and Casualty Ins. Co.	20699
		INSURER C: ACE Fire Underwriters Ins. Co.	20702
		INSURER D:	
		INSURER E:	
		INSURER F:	

COVERAGES **CERTIFICATE NUMBER:** 15855703 **REVISION NUMBER:** See below

THIS IS TO CERTIFY THAT THE POLICIES OF INSURANCE LISTED BELOW HAVE BEEN ISSUED TO THE INSURED NAMED ABOVE FOR THE POLICY PERIOD INDICATED. NOTWITHSTANDING ANY REQUIREMENT, TERM OR CONDITION OF ANY CONTRACT OR OTHER DOCUMENT WITH RESPECT TO WHICH THIS CERTIFICATE MAY BE ISSUED OR MAY PERTAIN, THE INSURANCE AFFORDED BY THE POLICIES DESCRIBED HEREIN IS SUBJECT TO ALL THE TERMS, EXCLUSIONS AND CONDITIONS OF SUCH POLICIES. LIMITS SHOWN MAY HAVE BEEN REDUCED BY PAID CLAIMS.

INSR LTR	TYPE OF INSURANCE	ADDL INSD	SUBR WVD	POLICY NUMBER	POLICY EFF (MM/DD/YYYY)	POLICY EXP (MM/DD/YYYY)	LIMITS
A	<input checked="" type="checkbox"/> COMMERCIAL GENERAL LIABILITY <input type="checkbox"/> CLAIMS-MADE <input checked="" type="checkbox"/> OCCUR GEN'L AGGREGATE LIMIT APPLIES PER: <input checked="" type="checkbox"/> POLICY <input type="checkbox"/> PRO-JECT <input type="checkbox"/> LOC OTHER:			XSL G47301038	06/01/2024	06/01/2025	EACH OCCURRENCE \$ 2,000,000 DAMAGE TO RENTED PREMISES (Ea occurrence) \$ 2,000,000 MED EXP (Any one person) \$ PERSONAL & ADV INJURY \$ 2,000,000 GENERAL AGGREGATE \$ 10,000,000 PRODUCTS - COMP/OP AGG \$ 4,000,000 \$
A	<input checked="" type="checkbox"/> AUTOMOBILE LIABILITY <input checked="" type="checkbox"/> ANY AUTO <input type="checkbox"/> OWNED AUTOS ONLY <input type="checkbox"/> SCHEDULED AUTOS <input type="checkbox"/> HIRED AUTOS ONLY <input type="checkbox"/> NON-OWNED AUTOS ONLY			ISA H10692167	06/01/2024	06/01/2025	COMBINED SINGLE LIMIT (Ea accident) \$ 4,000,000 BODILY INJURY (Per person) \$ BODILY INJURY (Per accident) \$ PROPERTY DAMAGE (Per accident) \$ \$
B	<input type="checkbox"/> UMBRELLA LIAB <input checked="" type="checkbox"/> OCCUR <input checked="" type="checkbox"/> EXCESS LIAB <input type="checkbox"/> CLAIMS-MADE DED RETENTION \$ \$10,000			XEU G72524470 004	06/01/2024	06/01/2025	EACH OCCURRENCE \$ 3,000,000 AGGREGATE \$ 3,000,000 \$
A	<input checked="" type="checkbox"/> WORKERS COMPENSATION AND EMPLOYERS' LIABILITY ANY PROPRIETOR/PARTNER/EXECUTIVE OFFICER/MEMBER EXCLUDED? (Mandatory in NH) If yes, describe under DESCRIPTION OF OPERATIONS below			WLR C50676109 (AOS) SCF C50676146 (WI)	06/01/2024 06/01/2024	06/01/2025 06/01/2025	<input checked="" type="checkbox"/> PER STATUTE <input type="checkbox"/> OTH-ER E L EACH ACCIDENT \$ 2,000,000 E L DISEASE - EA EMPLOYEE \$ 2,000,000 E L DISEASE - POLICY LIMIT \$ 2,000,000
C							

DESCRIPTION OF OPERATIONS / LOCATIONS / VEHICLES (ACORD 101, Additional Remarks Schedule, may be attached if more space is required)

The City of Spokane is included as additional insured on the general liability, where required by contract per policy terms and conditions, but only as respects to the products and/or operations, and only to the extent of negligence of Applied Industrial Technologies, Inc.

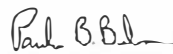
CERTIFICATE HOLDER City of Spokane 808 W. Spokane Falls Blvd. Spokane, WA 99201	CANCELLATION SHOULD ANY OF THE ABOVE DESCRIBED POLICIES BE CANCELLED BEFORE THE EXPIRATION DATE THEREOF, NOTICE WILL BE DELIVERED IN ACCORDANCE WITH THE POLICY PROVISIONS. AUTHORIZED REPRESENTATIVE 
---	---

The ACORD name and logo are registered marks of ACORD © 1988-2015 ACORD CORPORATION. All rights reserved.

ACORD 25 (2016/03)



CYB01A29001052/02/05/00/00



ADDITIONAL INSURED - DESIGNATED PERSON OR ORGANIZATION

Named Insured Applied Industrial Technologies, Inc.			Endorsement Number 19
Policy Symbol XSL	Policy Number G47301038	Policy Period 06/01/2024 to 06/01/2025	Effective Date of Endorsement
Issued By (Name of Insurance Company) ACE American Insurance Company			

Insert the policy number. The remainder of the information is to be completed only when this endorsement is issued subsequent to the preparation of the policy.

THIS ENDORSEMENT CHANGES THE POLICY. PLEASE READ IT CAREFULLY.

This endorsement modifies insurance provided under the following:

EXCESS COMMERCIAL GENERAL LIABILITY POLICY

SCHEDULE

Name of Person or Organization: Any person or organization whom you have agreed to include as an additional insured under a written contract, provided such contract was executed prior to the date of loss.

A. Section II – Who Is An Insured is amended to include as an additional insured the person(s) or organization(s) shown in the Schedule, but only with respect to liability for "bodily injury", "property damage" or "personal and advertising injury" caused, in whole or in part, by your acts or omissions or the acts or omissions of those acting on your behalf:

1. In the performance of your ongoing operations; or
2. In connection with your premises owned by or rented to you.

However:

1. The insurance afforded to such additional insured only applies to the extent permitted by law; and
2. If coverage provided to the additional insured is required by a contract or agreement, the insurance afforded to such additional insured will not be broader than that which you are required by the contract or agreement to provide for such additional insured.

B. With respect to the insurance afforded to these additional insureds, the following is added to Section III – Limits Of Insurance And Retained Limit:

If coverage provided to the additional insured is required by a contract or agreement, the most we will pay on behalf of the additional insured is the amount of insurance:

1. Required by the contract or agreement; or
 2. Available under the applicable Limits of Insurance shown in the Declarations;
- whichever is less.

This endorsement shall not increase the applicable Limits of Insurance shown in the Declarations.

Authorized Representative



Certificate of Insurance Attachment



Insured:

Applied Industrial Technologies, Inc.
 One Applied Plaza Cleveland, OH
 44115-5022

US subsidiaries of Applied Industrial Technologies, Inc.

A&H Fluid Technologies, Inc.	Bearings Pan American, Inc.
Advanced Control Solutions & Automation, Inc.	Carolina Fluid Components, LLC
Air Draulics Engineering Co.	Cangro Industries, LLC
AIT International Inc.	DTS Fluid Power, LLC
AIT Receivables, LLC	ESI Acquisition Corporation (d/b/a Engineered Sales, Inc., ESI Power Hydraulics, and Applied Engineered Systems)
Applied Automation, Inc. (dba Automation, Inc.)	FCX Performance, Inc.
Applied Bearing Distributors, LLC	Fluid Power Sales
Applied Fluid Power Holdings, LLC	FluidTech, LLC
Applied Industrial Technologies - CA LLC	Gibson Engineering Company, Inc.
Applied Industrial Technologies - Capital, Inc.	HUB Industrial Supply, Inc.
Applied Industrial Technologies - Dixie, Inc	HydroAir Hughes, LLC
Applied Industrial Technologies - PA LLC	HyQuip, LLC
Applied Industrial Technologies - PACIFIC LLC	Olympus Controls Corp.
Applied Maintenance Supplies & Solutions, LLC	Power Systems AHS, LLC
Applied US Energy - Oklahoma, LLC	R.R. Floody Company, Inc
Applied US Energy, Inc.	S. G. Morris Co., LLC
Applied US, L.P.	Sentinel Fluid Controls, LLC
Atlantic Fasteners Co., LLC	Spencer Fluid Power, Inc
Bay Advanced Technologies, LLC	Texas Oilpatch Services, LLC
Bearing Sales & Services, Inc.	

Foreign subsidiaries of Applied Industrial Technologies, Inc.

AIT Canada, ULC	Applied Northern Holdings, ULC
AIT Holding Corp.	Applied Nova Scotia Company
Applied Australia Holdings Pty Ltd	Bay Advanced Technologies Singapore Pte Ltd.
Applied Canada Holdings, ULC	BER International, Inc.
Applied Industrial Technologies Canada, ULC	Disenos Construcciones y Fabricaciones Hispanoamericans, S.A. (DICOFASA)
Applied Industrial Technologies Limited	Rafael Benitez Carrillo Inc.
Applied Industrial Technologies Pty Ltd	Seals Unlimited (1976) Incorporated
Applied Industrial Technologies, LP	Seals Unlimited Holding Co., Inc.
Applied Mexico Holdings, S.A. de C.V.	VYCMEX Mexico, S.A. de C.V.
Applied Mexico, S.A. de C.V	



Trade Names of Applied Industrial Technologies, Inc. and its subsidiaries



Advance Motions Systems	Ira Pump & Supply
Air and Hydraulics Engineering	Kent Fluid Power
Air Draulics	King Bearing
Air-Hydraulic Systems	Knox Oil Field Supply
Applied Engineered Systems	Mark Hydraulic
Applied MSS	MilRoc Distribution
Automation Inc	Minnesota Bearing Co.
Batesville Bearings	North Coast Instruments
Bay Pneumatics	Pacific Air Technologies
Collars and Couplings	PumpServe
Dees Fluid Power	PureServe
Elect Air	Reliance Industrial Products
Engineered Sales, Inc.	South Carolina State TM Filing
ESI Power Hydraulics	TOPS
Hydra Gear	Woodward Steel
HydroAir Dees	



Commercial Lines - (404) 923-3700
USI Insurance Services LLC
1 Concourse Parkway NE, Suite 700
Atlanta, GA 30328



CITY OF SPOKANE
808 W SPOKANE FALLS BLVD
SPOKANE WA 99201-3301

Would you like to receive this certificate via email or fax?

We offer expedited delivery to better serve our mutual clients.

To update the delivery method for revisions to this certificate and for next year's copy, please enter this information in your browser:

<https://www.cybersure.com/cybersure/forms/iyoc/cdmu.aspx>

When prompted, enter this information for security purposes:

Client ID: APPLIIND2
Cert ID: 15855703
Passcode: 2864D52F

Follow the instructions and let us know your delivery preference. You'll receive future copies of this certificate via the method you provide.

Thank you for helping us provide certificates to you more quickly.





< Business Lookup

License Information:

[New search](#) [Back to results](#)

Entity name: APPLIED INDUSTRIAL TECHNOLOGIES, INC.

Business name: APPLIED INDUSTRIAL TECHNOLOGIES MS09

Entity type: [Profit Corporation](#)

UBI #: 601-119-576

Business ID: 001

Location ID: 0015

Location: Active

Location address: 301 N FANCHER RD
SPOKANE VALLEY WA 99212-0831

Mailing address: TAX DEPT MS 30/412
PO BOX 6925
CLEVELAND OH 44101-2193

Excise tax and reseller permit status: [Click here](#)

Secretary of State status: [Click here](#)

Endorsements

Endorsements held at this location	License #	Count	Details	Status	Expiration date	First issuance date
Spokane General Business - Non-Resident	T12022794BUS			Active	Oct-31-2024	Oct-15-2012
Spokane Valley General Business				Active	Oct-31-2024	Aug-22-2018

Governing People May include governing people not registered with Secretary of State

Governing people	Title
CIESLAK, RYAN	
PLOETZ, JON S.	
SCHRIMSHER, NEIL A	
WELLS, DAVID K	

Registered Trade Names

Registered trade names	Status	First issued
APPLIED INDUSTRIAL TECHNOLOGIES	Active	Dec-15-2022

[View Additional Locations](#)

The Business Lookup information is updated nightly. Search date and time: 7/10/2024 12:55:20 PM



[Contact us](#)

How are we doing?

[Take our survey!](#)

Don't see what you expected?

[Check if your browser is supported](#)



**Agenda Sheet for City Council:****Committee:** Public Safety **Date:** 07/08/2024**Committee Agenda type:** Discussion**Date Rec'd**

7/8/2024

Clerk's File #

OPR 2024-0608

Cross Ref #**Project #****Council Meeting Date:** 08/12/2024**Submitting Dept**

COMMUNITY JUSTICE SERVICES

Bid #

RFP 6102-24

Contact Name/Phone

MICHAEL 509-622-5806

Requisition #

MASTER

Contact E-Mail

MDIAMOND@SPOKANECITY.ORG

Agenda Item Type

Contract Item

Council Sponsor(s)

PDILLON BWILKERSON MCATHCART

Agenda Item Name

0690-DRUG AND ALCOHOL TESTING CONTRACT

Agenda Wording

To establish a new drug and alcohol testing contract with Absolute Drug Testing, LLC.

Summary (Background)

Municipal Court has contracted for Drug and Alcohol Testing (urinalysis and mouth swabs) with Absolute Drug Testing, LLC. since 2018 and the current contract ends June 30,2024. The City and Court opened RFP 6102-24 for Drug and Alcohol Testing and, upon completion of the RFP process, has moved to establish a new contract with Absolute Drug Testing with an anticipated start date of July 1, 2024.

Lease? NO

Grant related? YES

Public Works? NO

Fiscal Impact

Approved in Current Year Budget? YES

Total Cost \$ 250,000

Current Year Cost \$ 42,358

Subsequent Year(s) Cost \$ 66,220

Narrative

Funding for drug and alcohol testing comes from grants including Administrative Office of the Courts, Washington Traffic Safety Commission, and City funds including: 0690-16100-23300-54101-99999; 1360-91220-12510-54101-99999; 1360-91217-12510-54101-99999.

Amount**Budget Account**

Expense \$ \$250,000

Various

Neutral \$

#

Neutral \$

#

Select \$

#

\$

#

\$

#



Continuation of Wording, Summary, Approvals, and Distribution

Agenda Wording

Summary (Background)

Approvals

<u>Dept Head</u>	DIAMOND, MICHAEL	<u>ACCOUNTING -</u>	MURRAY, MICHELLE
<u>Division Director</u>	LOGAN, MARY		
<u>Accounting Manager</u>	BUSTOS, KIM		
<u>Legal</u>	HARRINGTON,		
<u>For the Mayor</u>	JONES, GARRETT		

Additional Approvals

Distribution List

Missy Brum missyadt@gmail.com	cwahl@spokanecity.org
mdiamond@spokanecity.org	ddaniels@spokanecity.org
dtyurin@spokanecity.org	shenry@spokanecity.org

Committee Agenda Sheet

Public Safety & Community Health Committee

Committee Date	July 8, 2024
Submitting Department	Community Justice Services
Contact Name	Michael Diamond
Contact Email & Phone	mdiamond@spokanecity.org 622-5806
Council Sponsor(s)	CM Dillon
Select Agenda Item Type	<input type="checkbox"/> Consent <input checked="" type="checkbox"/> Discussion Time Requested: 5 Minutes
Agenda Item Name	Drug and Alcohol Testing Contract
Proposed Council Action	<input checked="" type="checkbox"/> Approval to proceed to Legislative Agenda <input type="checkbox"/> Information Only
Summary (Background)	<p>Municipal Court has contracted for Alcohol and Drug Testing (urinalysis and mouth swabs) with Absolute Drug Testing since 2018 and is currently under a Minor Contract ending June 30, 2024. The City and Court opened RFP 6102-24 for Alcohol and Drug Testing and upon completion of the RFP process has moved to establish a new contract with Absolute Drug Testing with an anticipated start date of July 1, 2024. The alcohol and drug testing will be provided for individuals engaged either pre-or-post disposition including Court, Therapeutic Court Programs or Community Justice Services. Drug and alcohol testing is a component of evidence-based practices in Therapeutic Courts and in Community Supervision and aligns with current Court and Community Justice Services programs and services.</p> <p>*use the Fiscal Impact box below for relevant financial information</p>
Fiscal Impact	
Approved in current year budget? <input checked="" type="checkbox"/> Yes <input type="checkbox"/> No <input type="checkbox"/> N/A Total Cost: <u>Not to exceed \$250,000 per annum</u> Current year cost: \$42,358 Subsequent year(s) cost: \$66,220 (2023)	
Narrative: <u>Funding for drug and alcohol testing comes general fund and from grants including Administrative Office of the Courts, Washington Traffic Safety Commission, and City funds including: 0690-16100-23300-54101-99999; 1360-91220-12510-54101-99999; 1360-91217-12510-54101-99999; and 0560-13100-12510-54101-99999 budget codes.</u>	
Funding Source <input type="checkbox"/> One-time <input checked="" type="checkbox"/> Recurring <input type="checkbox"/> N/A Specify funding source: Grant Is this funding source sustainable for future years, months, etc? Yes	
Expense Occurrence <input type="checkbox"/> One-time <input checked="" type="checkbox"/> Recurring <input type="checkbox"/> N/A Other budget impacts: (revenue generating, match requirements, etc.)	
Operations Impacts (If N/A, please give a brief description as to why)	
<ul style="list-style-type: none"> Drug and alcohol testing is a primary condition and requirement of Court process including pretrial release conditions, probation conditions, and/or therapeutic court conditions. Drug and alcohol testing is a component of evidence best practices for community supervision and in association of the National Association of Drug Court Professionals (now ALLRISE). 	

- Inclusion of drug and alcohol testing aligns with behavior modification techniques and case management to hold defendants accountable and responsible through the behavior change process and prior to, during, and upon completion of substance use treatment. The inclusion of drug and alcohol testing promotes community safety and aides in the reduction of recidivism.

Council Subcommittee Review

- To be reviewed at Public Safety & Community Health Committee for advancement to Legislative On July 22, 2024.



City of Spokane

MASTER PERSONAL SERVICES AGREEMENT

Title: **DRUG AND ALCOHOL TESTING SERVICES FOR MUNICIPAL COURT**

This Agreement is made and entered into by and between the **CITY OF SPOKANE** as ("City"), a Washington municipal corporation, and **ABSOLUTE DRUG TESTING, LLC**, whose address is 5433 North Government Way, Suite B, Coeur d'Alene, Idaho 83815, as ("Company"), individually hereafter referenced as a "party", and together as the "parties".

The parties agree as follows:

1. PERFORMANCE.

The Company shall provide Drug and Alcohol Testing Service for Municipal Court, in accordance with RFP 6102-24 issued by the City, including all subsequent addendums and questionnaire, and the Company's Proposal dated May 13, 2024, which is attached as Exhibit B. In the event of a conflict between the Company and this City Contract, the terms of this contract will control.

2. TERM OF AGREEMENT.

The term of this Agreement begins on July 1, 2024, and shall run through June 30, 2025, unless amended by written agreement or terminated earlier under the provisions. This Agreement may be renewed by written agreement of the parties not to exceed four (4) additional one (1) year contract periods.

3. COMPENSATION / PAYMENT.

The City shall pay Company for services under this Agreement in accordance with Exhibits A and B to Company's Proposal not to exceed **TWO HUNDRED FIFTY THOUSAND AND NO/100 DOLLARS (\$250,000.00)**, plus applicable tax, unless modified by a written amendment to this Agreement. This is the maximum amount to be paid under this Agreement for the work described in Section 1 above, and shall not be exceeded without the prior written authorization of the City in the form of an executed amendment to this Agreement.

The Company shall submit its applications for payment to Municipal Court, Administration Office, West 1100 Mallon Avenue, Spokane, Washington 99201. **Payment will be made via direct deposit/ACH** within thirty (30) days after receipt of the Company's application except as provided by state law. If the City objects to all or any portion of the invoice, it shall notify the Company and reserves the right to only pay that portion of the invoice not in dispute. In that event, the parties shall immediately make every effort to settle the disputed amount.

4. TAXES, FEES AND LICENSES.

- A. Company shall pay and maintain in current status, all necessary licenses, fees, assessments, permit charges, etc. necessary to conduct the work included under this Agreement. It is the Company's sole responsibility to monitor and determine changes or the enactment of any subsequent requirements for said fees, assessments, or changes and to immediately comply.
- B. The cost of any permits, licenses, fees, etc. arising as a result of the projects included in this Agreement shall be included in the project budgets.

5. CITY OF SPOKANE BUSINESS LICENSE.

Section 8.01.070 of the Spokane Municipal Code states that no person may engage in business with the City without first having obtained a valid annual business registration. The Company shall be responsible for contacting the State of Washington Business License Services at www.dor.wa.gov or 360-705-6741 to obtain a business registration. If the Company does not believe it is required to obtain a business registration, it may contact the City's Taxes and Licenses Division at (509) 625-6070 to request an exemption status determination.

6. SOCIAL EQUITY REQUIREMENTS / NON-DISCRIMINATION.

No individual shall be excluded from participation in, denied the benefit of, subjected to discrimination under, or denied employment in the administration of or in connection with this Agreement because of age, sex, race, color, religion, creed, marital status, familial status, sexual orientation including gender expression or gender identity, national origin, honorably discharged veteran or military status, the presence of any sensory, mental or physical disability, or use of a service animal by a person with disabilities. The Company agrees to comply with, and to require that all subcontractors comply with, federal, state and local nondiscrimination laws, including but not limited to: the Civil Rights Act of 1964, the Rehabilitation Act of 1973, the Age Discrimination in Employment Act, and the American's With Disabilities Act, to the extent those laws are applicable.

7. INDEMNIFICATION.

The Company shall defend, indemnify, and hold the City and its officers and employees harmless from all claims, demands, or suits at law or equity asserted by third parties for bodily injury (including death) and/or property damage which arise from the Company's negligence or willful misconduct under this Agreement, including attorneys' fees and litigation costs; provided that nothing herein shall require a Company to indemnify the City against and hold harmless the City from claims, demands or suits based solely upon the negligence of the City, its agents, officers, and employees. If a claim or suit is caused by or results from the concurrent negligence of the Company's agents or employees and the City, its agents, officers and employees, this indemnity provision shall be valid and enforceable to the extent of the negligence of the Company, its agents or employees. The Company specifically assumes liability and agrees to defend, indemnify, and hold the City harmless for actions brought by the Company's own employees against the City and, solely for the purpose of this indemnification and defense, the Company specifically waives any immunity under the Washington State industrial insurance law, or Title 51 RCW. The Company recognizes that this waiver was specifically entered into pursuant to the provisions of RCW 4.24.115 and was the subject of mutual negotiation. The indemnity and agreement to defend and hold the City harmless provided for in this section shall survive any termination or expiration of this agreement.

8. INSURANCE.

During the period of the Agreement, the Company shall maintain in force at its own expense, each insurance noted below with companies or through sources approved by the State Insurance Commissioner pursuant to Title 48 RCW:

- A. **Worker's Compensation Insurance** in compliance with RCW 51.12.020, which requires subject employers to provide workers' compensation coverage for all their subject workers and Employer's Liability Insurance in the amount of \$1,000,000;
- B. **General Liability Insurance** on an occurrence basis, with a combined single limit of not less than \$1,000,000 each occurrence for bodily injury and property damage. It shall include contractual liability coverage for the indemnity provided under this Agreement. It shall provide that the City, its officers and employees are additional insureds but only with respect to the Company's services to be provided under this Agreement;
 - i. Acceptable **supplementary Umbrella insurance** coverage combined with Company's General Liability insurance policy must be a minimum of \$1,000,000, in order to meet the insurance coverage limits required in this Agreement; and
- C. **Automobile Liability Insurance** with a combined single limit, or the equivalent of not less than \$1,000,000 each accident for bodily injury and property damage, including coverage for owned, hired and non-owned vehicles.

There shall be no cancellation, material change, reduction of limits or intent not to renew the insurance coverage(s) without forty-five (45) days written notice from the Company or its insurer(s) to the City. As evidence of the insurance coverage(s) required by this Agreement, the Company shall furnish acceptable Certificates of Insurance (COI) to the City at the time it returns this signed Agreement. The certificate shall specify the City of Spokane as "Additional Insured" specifically for Company's services under this Agreement, as well as all of the parties who are additional insureds, and include applicable policy endorsements, the forty-five (45) day cancellation clause, and the deduction or retention level. The Company shall be financially responsible for all pertinent deductibles, self-insured retentions, and/or self-insurance.

9. DEBARMENT AND SUSPENSION.

The Company has provided its certification that it is in compliance with and shall not contract with individuals or organizations which are debarred, suspended, or otherwise excluded from or ineligible from participation in Federal Assistance Programs under Executive Order 12549 and "Debarment and Suspension", codified at 29 CFR part 98.

10. AUDIT.

The Company and its sub-contractor shall maintain for a minimum of three (3) years following final payment all records related to its performance of the Agreement. The Company and its sub-contractors shall provide access to authorized City representatives, at reasonable times and in a reasonable manner to inspect and copy any such record. In the event of conflict between this provision and related auditing provisions required under federal law applicable to the Agreement, the federal law shall prevail.

11. ASSIGNMENT AND SUBCONTRACTING.

The Company shall not assign or subcontract its obligations under this Agreement without the City's written consent, which may be granted or withheld in the City's sole discretion. Any subcontract made by the Company shall incorporate by reference this Agreement, except as otherwise provided. The Company shall ensure that all subcontractors comply with the obligations and requirements of the subcontract. The City's consent to any assignment or subcontract does not release the Company from liability or any obligation within this Agreement, whether before or after City consent, assignment or subcontract.

12. TERMINATION.

Either party may terminate this Agreement, with or without cause, by ten (10) days written notice to the other party. In the event of such termination, the City shall pay the Company for all work previously authorized and performed prior to the termination date.

13. STANDARD OF PERFORMANCE.

The standard of performance applicable to the Company's services will be the degree of skill and diligence normally employed by a professional Company performing the same or similar services at the time the services under this Agreement are performed.

14. OWNERSHIP AND USE OF RECORDS AND DOCUMENTS.

Original documents, drawings, designs, reports, or any other records developed or created under this Agreement shall belong to and become the property of the City. All records submitted by the City to the Company shall be safeguarded by the Company. The Company shall make such data, documents and files available to the City upon the City's request. If the City's use of the Company's records or data is not related to this project, it shall be without liability or legal exposure to the Company.

Under Washington State Law (reference RCW Chapter 42.56, the *Public Records Act* [PRA]) all materials received or created by the City of Spokane are **public records** and are available to the public for viewing via the City Clerk's Records (online) or a valid Public Records Request (PRR).

15. ANTI KICK-BACK.

No officer or employee of the City of Spokane, having the power or duty to perform an official act or action related to this Agreement shall have or acquire any interest in the Agreement, or have solicited, accepted or granted a present or future gift, favor, service or other thing of value from or to any person involved in this Agreement.

16. MISCELLANEOUS PROVISIONS.

A. **Amendments/Modifications:** This Agreement may be modified by the City in writing when necessary, and no modification or Amendment of this Agreement shall be effective unless signed by an authorized representative of each of the parties hereto.

B. The Company, at no expense to the City, shall comply with all laws of the United States and Washington, the Charter and ordinances of the City of Spokane; and rules, regulations, orders and directives of their administrative agencies and officers. Without limiting the generality of this paragraph, the Company shall comply with the requirements of this Section.

C. This Agreement shall be construed and interpreted under the laws of Washington. The venue of any action brought shall be in a court of competent jurisdiction, located in Spokane County, Washington.

D. **Captions:** The titles of sections or subsections are for convenience only and do not define or limit the contents.

E. **Severability:** If any term or provision is determined by a court of competent jurisdiction to be invalid or unenforceable, the remainder of this Agreement shall not be affected, and each term and provision shall be valid and enforceable to the fullest extent permitted by law.

F. **Waiver:** No covenant, term or condition or the breach shall be deemed waived, except by written consent of the party against whom the waiver is claimed, and any waiver of the breach of any covenant, term or condition shall not be deemed a waiver of any preceding or succeeding breach of the same or any other covenant, term of condition. Neither the acceptance by the City of any performance by the Company after the time the same shall have become due nor payment to the Company for any portion of the Work shall constitute a waiver by the City of the breach or default of any covenant, term or condition unless otherwise expressly agreed to by the City in writing.

G. **Entire Agreement:** This document along with any exhibits and all attachments, and subsequently issued addenda, comprises the entire agreement between the City and the Company. If conflict occurs between Agreement documents and applicable laws, codes, ordinances or regulations, the most stringent or legally binding requirement shall govern and be considered a part of this Agreement to afford the City the maximum benefits.

H. **No personal liability:** No officer, agent or authorized employee of the City shall be personally responsible for any liability arising under this Agreement, whether expressed or implied, nor for any statement or representation made or in any connection with this Agreement.

IN WITNESS WHEREOF, in consideration of the terms, conditions and covenants contained, or attached and incorporated and made a part, the parties have executed this Agreement by having legally-binding representatives affix their signatures below.

ABSOLUTE DRUG TESTING, LLC

CITY OF SPOKANE

By _____
Signature Date

By _____
Signature Date

Type or Print Name

Type or Print Name

Title

Title

Attest:

Approved as to form:

City Clerk

Assistant City Attorney

Attachments that are part of this Agreement:

- Exhibit A – Certificate Regarding Debarment
 - Exhibit B – Company’s Proposal dated May 13, 2024
- 24-105

EXHIBIT A

CERTIFICATION REGARDING DEBARMENT, SUSPENSION, INELIGIBILITY AND VOLUNTARY EXCLUSION

1. The undersigned (i.e., signatory for the Subrecipient / Contractor / Consultant) certifies, to the best of its knowledge and belief, that it and its principals:
 - a. Are not presently debarred, suspended, proposed for debarment, declared ineligible, or voluntarily excluded from covered transactions by any federal department or agency;
 - b. Have not within a three-year period preceding this contract been convicted or had a civil judgment rendered against them for commission of fraud or a criminal offense in connection with obtaining, attempting to obtain, or performing a public (federal, state, or local) transaction or contract under a public transaction; violation of federal or state antitrust statutes or commission of embezzlement, theft, forgery, bribery, falsification or destruction of records, making false statements, tax evasion, receiving stolen property, making false claims, or obstruction of justice;
 - c. Are not presently indicted or otherwise criminally or civilly charged by a government entity (federal, state, or local) with commission of any of the offenses enumerated in paragraph (1)(b) of this certification; and,
 - d. Have not within a three-year period preceding this contract had one or more public transactions (federal, state, or local) terminated for cause or default.

2. The undersigned agrees by signing this contract that it shall not knowingly enter into any lower tier covered transaction with a person who is debarred, suspended, declared ineligible, or voluntarily excluded from participation in this covered transaction.

3. The undersigned further agrees by signing this contract that it will include the following clause, without modification, in all lower tier covered transactions and in all solicitations for lower tier covered transactions:

Certification Regarding Debarment, Suspension, Ineligibility and Voluntary Exclusion – Lower Tier Covered Transactions

1. The lower tier contractor certified, by signing this contract that neither it nor its principals is presently debarred, suspended, proposed for debarment, declared ineligible, or voluntarily excluded from participation in this transaction by any federal department or agency.
2. Where the lower tier contractor is unable to certify to any of the statements in this contract, such contractor shall attach an explanation to this contract.

4. I understand that a false statement of this certification may be grounds for termination of the contract.

<hr style="border: none; border-top: 1px solid black; margin-bottom: 5px;"/> Name of Subrecipient / Contractor / Consultant (Type or Print)	<hr style="border: none; border-top: 1px solid black; margin-bottom: 5px;"/> Program Title (Type or Print)
<hr style="border: none; border-top: 1px solid black; margin-bottom: 5px;"/> Name of Certifying Official (Type or Print)	<hr style="border: none; border-top: 1px solid black; margin-bottom: 5px;"/> Signature
<hr style="border: none; border-top: 1px solid black; margin-bottom: 5px;"/> Title of Certifying Official (Type or Print)	<hr style="border: none; border-top: 1px solid black; margin-bottom: 5px;"/> Date (Type or Print)

EXHIBIT B

SCOPE OF SERVICES

SCOPE OF SERVICES

The scope of services to provide under contract include, but is not limited to the following:

A. Drug and Alcohol testing must adhere to evidence-based practices including, but not limited to, drug and alcohol testing protocols recognized by Washington State RCW, Washington State Administrative Office of the Courts, and AllRise (formerly NADCP), including updates:

1. [AllRise - Adult Treatment Court Best Practice Standards](#)
2. [Washington State RCW 2.30 - Therapeutic Courts](#)
3. [Washington Courts - Therapeutic Courts](#)

B. Drug and alcohol testing must be frequent (defined by A/D referral), random, and observed (same sex) urine analyses (UA) drug and alcohol tests. Gender identity means an individual's internal sense of being male or female, which may be different from an individual's assigned at birth – observed testing shall occur based on a person's sex assigned at birth or pursuant to completed gender reassignment surgery.

C. Testing must be provided at authorized testing facility locations and be maintained in a clean, professional, and welcoming manner.

D. The probability of being tested in the weekend or on holidays must be the same as on any other days. Testing days must be selected by a computerized randomizer and are not to be grouped by therapeutic court participation, court program, and/or probation services.

E. Testing services must be coordinated, and information communicated with the participant's Court, Court Program, or Community Justice Services representative.

F. The Firm is responsible for timely communication with participants during testing and following up with agency contacts after each test regarding relevant statements, behaviors, or observations immediately prior to, during, and after testing.

G. The Firm must examine test specimens for all unauthorized substances that are suspected to be used by participants. Randomly selected specimens are to be tested periodically for a broader range of substances to detect new substances that might be emerging in the drug court population.

H. The Firm is responsible for following all evidence-based practices to reduce the risk of the participant providing an adulterated, tampered, or substitute specimen.

I. When a participant denies substance use in response to a positive screening test, the Firm will send a portion of the same specimen to a Substance Abuse and Mental Health Services Administration (SAMHSA) approved laboratory for confirmation analysis using the instrumented test LC/MS and/or GC/MS. When a participant admits to using the drug or alcohol identified by the screening procedure, they shall make that admission in writing on a court provided form. If there is no admission, confirmation of presumptive positive tests is mandatory. The Firm is responsible to provide confirmation test results with a goal of turnaround within 48 hours of sample collection.

- J. The Firm is responsible for routinely examining and testing specimens for evidence of dilution and adulteration including testing for temperature, creatinine, and specific gravity.
- K. The Firm is required to be trained on and follow generally accepted chain-of-custody procedures when handling test specimens. A chain-of-custody form shall be completed when a urine sample has been collected and is being transported from the testing site. This form ensures the identity and integrity of the sample through transport, testing, and reporting of results.
- L. The Firm and the associated SAMHSA approved lab used for confirmation testing must cooperate if the court determines that scientific, technical, or other specialized knowledge will assist the trier of fact to understand the evidence or to determine a fact in issue. A witness qualified as an expert by knowledge, skill, experience, training, or education will testify in the form of an opinion or otherwise if (1) the testimony is based on sufficient facts or data, (2) the testimony is the product of reliable principles and methods, and (3) the witness has applied the principles and methods reliably to the facts of the case.
- M. The Firm is required to comply with 42 USC § 290dd-2, the federal law that protects the confidentiality of the identity, diagnosis, prognosis, or treatment of any patient records that are maintained in connection with the performance of any federally assisted program or activity relating to substance abuse treatment, as well as 42 CFR, Part 2, the federal law regarding confidentiality of substance use disorder patient records.
- N. The Firm is required to comply with the Health Insurance Portability and Accountability Act (HIPAA). HIPAA is a federal law that created national standards to protect sensitive patient health information from being disclosed without the patient's consent or knowledge.
- O. The Firm is required to provide expeditious communication with the agency contacts and to make information available to or be available for Staffing and Core Team meetings as requested.
- P. The Firm will participate in interdisciplinary trainings as requested.
- Q. The Firm will accommodate all requested auditing activities at the request of the City of Spokane or Municipal Court to ensure that services are being performed as described in this RFP.
- R. The Firm will provide testing including, but not limited to, the following substances/drug panel screening tests: (It is understood that Firms may have their own customized/created panels).

SPOKANE DRUG AND ALCOHOL TESTING SERVICES FOR MUNICIPAL COURT

7PNL Screen Testing: \$23.40

AMP	Amphetamine Screen	d-Amphetamines
METH	Methamphetamine Screen	Methamphetamine
COC	Cocaine Screen	Benzoyllecgonine
BNZO	Benzodizepines	Oxazepam
FTY	Fentanyl Screen	Norfentanyl
OXY	Oxycodone Screen	Oxycodone
THC	Marijuana Screen	11-nor-THC 9 COOH
OP	Opiates Screen	Morphine

8PNL Screen Testing: \$25.00

AMP	Amphetamine Screen	d-Amphetamines
METH	Methamphetamine	Methamphetamine
COC	Cocaine Screen	Benzoyllecgonine
BENZO	Benzodiazepines	Oxazepam
OP	Opiates Screen	Morphine
OXY	Oxycodone	Oxycodone
FTY	Fentanyl Screen	Norfentanyl
THC	Marijuana Screen	11-nor-THC 9 COOH
ETG	Ethyl Glucuronide Screen	Ethyl Glucuronide

Alcohol & Alcohol Metabolites	Ethanol (EtOH), Ethyl glucuronide (EtG)	Ethyl Sulfate (EtS)	\$17.40
Amphetamines	Amphetamines, Methamphetamines, MDA and MSMA		\$17.40
Bath Salts	Synthetic Cathinones includes confirmation		\$75.00
Benzodiazepines	7-Aminoclonazepam, 7-Aminoflunitrazepam, Alpha-OH-Alprazolam Alprazolam, Alph-OH-Midazolam, Alpha-OH-Triazolam, Deskalkylflurazepam, Lorazepam, Nordiazepam, Oxazepam & Ter		\$17.40
Buprenorphine	Buprenorphine and Norbuprenorphine		\$17.40
Cocaine	Benzoyllecgonine		\$17.40
Ecstasy	MDMA & MDA		\$17.40
Fentanyl	Synthetic Opioid		\$20.00
Kratom	Mitragynine		\$20.00
Marijuana	THC and Marijuana Metabolite		\$17.40
Marijuana, Synthetic (Spice)	AM-2201, JWH-018, JWH-019 JWH-073 and JWH-250 includes confirmation		\$75.00
Methadone	Methadone and Methadone Metabolite		\$17.40
Opiates	Codeine, Morphine, Hydrocodone, Hydromorphone Oxycodone and Oxymorphone		\$17.40
Tramadol (Ultram)	Tramadol and/or Metabolite		\$17.40
Other Miscellaneous	Pentazocine, Propoxyphene, Naluphine, Meperidine, Metabolite Metabolite, Ketamine Metabolite, Butorphanol Metabolite		MARKET PRICING.

Note: Per the RFP ADT did not see any cost requests for confirmation however in the past ADT-			
has provided a 7pnl analyzer screen and included a confirmation for one assay for \$40.00			
ADT	Past Confirmation cost for reference		
	EtG /EIA screen with confirmation		\$30
	Fentynal lab confirm		\$40
	Buprenorphine confirm		\$40
	Kratom Urine Confirmation		\$40
	Ketamine Confirmation		\$40



CERTIFICATE OF LIABILITY INSURANCE

DATE (MM/DD/YYYY)
03/18/2024

THIS CERTIFICATE IS ISSUED AS A MATTER OF INFORMATION ONLY AND CONFERS NO RIGHTS UPON THE CERTIFICATE HOLDER. THIS CERTIFICATE DOES NOT AFFIRMATIVELY OR NEGATIVELY AMEND, EXTEND OR ALTER THE COVERAGE AFFORDED BY THE POLICIES BELOW. THIS CERTIFICATE OF INSURANCE DOES NOT CONSTITUTE A CONTRACT BETWEEN THE ISSUING INSURER(S), AUTHORIZED REPRESENTATIVE OR PRODUCER, AND THE CERTIFICATE HOLDER.

IMPORTANT: If the certificate holder is an ADDITIONAL INSURED, the policy(ies) must have ADDITIONAL INSURED provisions or be endorsed. If SUBROGATION IS WAIVED, subject to the terms and conditions of the policy, certain policies may require an endorsement. A statement on this certificate does not confer rights to the certificate holder in lieu of such endorsement(s).

PRODUCER David Lunceford Insurance Agency 610 W Hubbard Street, Suite 121 Coeur d'Alene ID 83814	CONTACT NAME: David Lunceford PHONE (A/C, NO, EXT): 208-292-4541												
	FAX (A/C, NO): ///												
	E-MAIL ADDRESS: dlunceford@farmersagent.com												
	INSURER(S) AFFORDING COVERAGE												
INSURED ABSOLUTE DRUG TESTING LLC 5433 N GOVERNMENT WAY STE B COEUR D ALENE ID 83815	<table border="1" style="width: 100%; border-collapse: collapse;"> <tr> <td style="width: 80%;">INSURER A: Truck Insurance Exchange</td> <td style="width: 20%;">21709</td> </tr> <tr> <td>INSURER B: Farmers Insurance Exchange</td> <td>21652</td> </tr> <tr> <td>INSURER C: Mid Century Insurance Company</td> <td>21687</td> </tr> <tr> <td>INSURER D: Idaho State Insurance Fund</td> <td>36129</td> </tr> <tr> <td>INSURER E:</td> <td></td> </tr> <tr> <td>INSURER F:</td> <td></td> </tr> </table>	INSURER A: Truck Insurance Exchange	21709	INSURER B: Farmers Insurance Exchange	21652	INSURER C: Mid Century Insurance Company	21687	INSURER D: Idaho State Insurance Fund	36129	INSURER E:		INSURER F:	
INSURER A: Truck Insurance Exchange	21709												
INSURER B: Farmers Insurance Exchange	21652												
INSURER C: Mid Century Insurance Company	21687												
INSURER D: Idaho State Insurance Fund	36129												
INSURER E:													
INSURER F:													

COVERAGES **CERTIFICATE NUMBER:** **REVISION NUMBER:**

THIS IS TO CERTIFY THAT THE POLICIES OF INSURANCE LISTED BELOW HAVE BEEN ISSUED TO THE INSURED NAME ABOVE FOR THE POLICY PERIOD INDICATED. NOTWITHSTANDING ANY REQUIREMENT, TERM OR CONDITION OF ANY CONTRACT OR OTHER DOCUMENT WITH RESPECT TO WHICH THIS CERTIFICATE MAY BE ISSUED OR MAY PERTAIN, THE INSURANCE AFFORDED BY THE POLICIES DESCRIBED HEREIN IS SUBJECT TO ALL THE TERMS, EXCLUSIONS AND CONDITIONS OF SUCH POLICIES. LIMITS SHOWN MAY HAVE BEEN REDUCED BY PAID CLAIMS.

INSR LTR	TYPE OF INSURANCE	ADDTL INSD	SUBR WVD	POLICY NUMBER	POLICY EFF (MM/DD/YYYY)	POLICY EXP (MM/DD/YYYY)	LIMITS
C	<input checked="" type="checkbox"/> COMMERCIAL GENERAL LIABILITY <input type="checkbox"/> CLAIMS-MADE <input checked="" type="checkbox"/> OCCUR GEN'L AGGREGATE LIMIT APPLIES PER: <input checked="" type="checkbox"/> POLICY <input type="checkbox"/> PROJECT <input type="checkbox"/> LOC OTHER:	Y		605433845	01/23/2024	01/23/2025	EACH OCCURRENCE \$ 1,000,000
							DAMAGE TO RENTED PREMISES (Ea Occurrence) \$ 250,000
							MED EXP (Any one person) \$ 5,000
							PERSONAL & ADV INJURY \$ 1,000,000
							GENERAL AGGREGATE \$ 2,000,000
							PRODUCTS - COMP/OP AGG \$ 2,000,000
A	AUTOMOBILE LIABILITY <input type="checkbox"/> ANY AUTO <input type="checkbox"/> OWNED AUTOS ONLY <input checked="" type="checkbox"/> SCHEDULED AUTOS <input checked="" type="checkbox"/> HIRED AUTOS ONLY <input checked="" type="checkbox"/> NON-OWNED AUTOS ONLY	Y		605433845	01/23/2024	01/23/2025	COMBINED SINGLE LIMIT (Ea accident) \$ 1,000,000
							BODILY INJURY (Per person) \$
							BODILY INJURY (Per accident) \$
							PROPERTY DAMAGE (Per accident) \$
	UMBRELLA LIAB <input type="checkbox"/> OCCUR EXCESS LIAB <input type="checkbox"/> CLAIMS-MADE DED RETENTION \$						EACH OCCURRENCE \$
							AGGREGATE \$
D	WORKERS COMPENSATION AND EMPLOYERS' LIABILITY ANY PROPRIETOR/PARTNER/ EXECUTIVE OFFICER/MEMBER EXCLUDED? (Mandatory in NH) Y/N If yes, describe under DESCRIPTION OF OPERATIONS below Y	N/A		63591	03/05/2024	03/05/2025	PER STATUTE OTHER \$
							E.L. EACH ACCIDENT \$ 100,000
							E.L. DISEASE - EA EMPLOYEE \$ 100,000
							E.L. DISEASE - POLICY LIMIT \$ 500,000

DESCRIPTION OF OPERATIONS/LOCATIONS/VEHICLES (ACORD 101, Additional Remarks Schedule, may be attached if more space is required)

CERTIFICATE HOLDER CITY OF SPOKANE ITS OFFICERS, AGENTS, AND EMPLOYEES 808 W SPOKANE FALLS BLVD SPOKANE WA 99201	CANCELLATION SHOULD ANY OF THE ABOVE DESCRIBED POLICIES BE CANCELLED BEFORE THE EXPIRATION DATE THEREOF, NOTICE WILL BE DELIVERED IN ACCORDANCE WITH THE POLICY PROVISIONS. AUTHORIZED REPRESENTATIVE
---	--



< Business Lookup

License Information:

[New search](#) [Back to results](#)

Entity name: ABSOLUTE DRUG TESTING, LLC

Business name: ABSOLUTE DRUG TESTING LLC.

Entity type: Limited Liability Company

UBI #: 603-276-806

Business ID: 001

Location ID: 0001

Location: Active

Location address: 1710 W MISSION ST
SPOKANE WA 99202

Mailing address: 2797 S MELLICK RD
POST FALLS ID 83854-8701



Excise tax and reseller permit status:

[Click here](#)

Secretary of State status:

[Click here](#)

Endorsements

Endorsements held at this lo	License #	Count	Details	Status	Expiration da	First issuance
Spokane General Business				Active	Jan-31-2025	Mar-29-2013

Governing People May include governing people not registered with Secretary of State

Governing people	Title
JETT, CHARLES	

Registered Trade Names

Registered trade names	Status	First issued
ABSOLUTE DRUG TESTING LLC.	Active	Mar-29-2013
ABSOLUTE MOBILE DRUG TESTING	Active	Jan-07-2019

The Business Lookup information is updated nightly. Search date and time:
6/18/2024 8:44:42 AM



Contact us

How are we doing?

Take our survey!

Don't see what you expected?

Check if your browser is supported





Agenda Sheet for City Council:

Committee: PIES **Date:** 07/15/2024

Committee Agenda type: Consent

Date Rec'd 7/15/2024

Clerk's File # OPR 2024-0609

Cross Ref #

Project #

Council Meeting Date: 08/12/2024

Submitting Dept	COMMUNITY, HOUSING & HUMAN	Bid #	
------------------------	----------------------------	--------------	--

Contact Name/Phone	ARIELLE 5278	Requisition #	
---------------------------	--------------	----------------------	--

Contact E-Mail	ARIELLEANDERSON@SPOKANECITY.		
-----------------------	------------------------------	--	--

Agenda Item Type	Contract Item		
-------------------------	---------------	--	--

Council Sponsor(s)	ZZAPPONE JBINGLE KKLITZKE		
---------------------------	---------------------------	--	--

Agenda Item Name	1680- HOUSING NAVIGATION CENTER OPERATOR AND PRIMARY SERVICE		
-------------------------	--	--	--

Agenda Wording

The CHHS Department requests that the CHHS RFP Committee's recommendation to approve the joint application of Empire Health Foundation and Revive as the Housing Navigator and Primary Service Provider.

Summary (Background)

The CHHS board has voted to approve Empire Health Foundation as the Proposed Operator as well as Revive Counseling Spokane, PLLC as the Proposed Service Provider. The total available for this RFP is approximately \$3,850,000 and will be for a period from July 1, 2024, through June 30, 2025.

Lease? NO Grant related? YES Public Works? NO

Fiscal Impact

Approved in Current Year Budget? NO

Total Cost \$ 3,850,000

Current Year Cost \$

Subsequent Year(s) Cost \$

Narrative

The funds supporting this RFP were appropriated by the Washington State Legislature and will be distributed by Commerce. The goal of these funds are to support the continued decommissioning of the TRAC Emergency Shelter by the Fall of 2024.

Amount

Budget Account

Expense	\$ 3,850,000	# 1540-95571-65410-54201-99999
Select	\$	#
Select	\$	#
Select	\$	#
	\$	#
	\$	#



Continuation of Wording, Summary, Approvals, and Distribution

Agenda Wording

Summary (Background)

Approvals

Dept Head

ANDERSON, ARIELLE M.

Division Director

KINDER, DAWN

Accounting Manager

MURRAY, MICHELLE

Legal

BEATTIE, LAUREN

For the Mayor

PICCOLO, MIKE

Additional Approvals

ACCOUNTING -

MURRAY, MICHELLE

Distribution List

arielleanderson@spokanecity.org

dkinder@spokanecity.org

dnorman@spokanecity.org

Committee Agenda Sheet

Urban Experience Committee

Committee Date	Urban Experience
Submitting Department	Community, Housing, and Human Services
Contact Name	Arielle Anderson
Contact Email & Phone	arielleanderson@spokanecity.org Ext. 5278
Council Sponsor(s)	<u>Zappone</u>
Select Agenda Item Type	<input checked="" type="checkbox"/> Consent <input type="checkbox"/> Discussion Time Requested: 10 Minutes
Agenda Item Name	CHHS Board funding recommendation for the Housing Navigation Center Operator and Primary Service Provider RFP
Proposed Council Action	<input checked="" type="checkbox"/> Approval to proceed to Legislative Agenda <input type="checkbox"/> Information Only
Summary (Background) *use the Fiscal Impact box below for relevant financial information	<p>On June 5, 2024, the CHHS Department published the Housing Navigation Center Operator and Service Provider NOFA. Prior to it being published, the CHHS Staff held community meetings to elicit feedback on a scattered site approach. These meetings, along with the 2024 Emergency Shelter Audit, informed this RFP. Additionally, The Department held an optional Technical Assistance workshop on June 7, 2024, where at least three to four service providers were present, as well as community members.</p> <p>It should be noted that since this is a pilot program, which we hope will serve as a blueprint for other Housing Navigation Centers throughout our Region, it needed to be nimble enough to respond to community feedback as it is rolled out, which served as the impetus for opting for an Operator as opposed to entering into a subrecipient relationship. Towards this end, CHHS will work with the Operator, Primary Service Provider, Neighborhoods, Council, etc, to cultivate a healthy community feedback loop as we rollout this new model. The CHHS RFP Committee received one joint application from Empire Health Foundation (Operator) and Revive (Primary Service Provider). The scoring rubric and NOFA have been submitted as attachments to this Briefing Paper. The CHHS RFP Committee recommended approving the application on July 3, 2024. The CHHS Board unanimously voted to approve the CHHS RFP Committee’s recommendation and to forward for Council consideration.</p>
Fiscal Impact	
Approved in current year budget? <input type="checkbox"/> Yes <input checked="" type="checkbox"/> No <input type="checkbox"/> N/A	
Total Cost: <u>Click or tap here to enter text.</u>	
Current year cost:	
Subsequent year(s) cost: N/A	
Narrative: <i>The funds supporting this RFP were appropriated by the Washington State Legislature and will be distributed by Commerce. The goal of these funds are to support the continued decommissioning of the TRAC Emergency Shelter by the Fall of 2024.</i>	
Funding Source <input checked="" type="checkbox"/> One-time <input type="checkbox"/> Recurring <input type="checkbox"/> N/A	
Specify funding source: Grant	
Is this funding source sustainable for future years, months, etc? <i>This funding is a one-time, 12-month grant, beginning July 1, 2024-June 30 2025. The success of this program will provide future leveraging for competitive grants offered through state and federal funds for its continued stability.</i>	
Expense Occurrence <input checked="" type="checkbox"/> One-time <input type="checkbox"/> Recurring <input type="checkbox"/> N/A	

Other budget impacts: (revenue generating, match requirements, etc.) N/A

Operations Impacts (If N/A, please give a brief description as to why). As with all grants, there will be programmatic and fiscal implications to administer these funds, but no more than other grants currently being managed by CHHS Staff.

What impacts would the proposal have on historically excluded communities? *We believe that implementing a scattered site model will help in reducing marginalized populations who are experiencing homelessness as the overall goal is to provide boutique style shelters that serve specific sub populations. Additionally, since the Operator is responsible for entering into subrecipient agreements, they will be better equipped to establish relationships with smaller, grassroots/local providers, that the City would otherwise be unable to accommodate given the fiscal and insurance requirements needed for subrecipients to be legally obligated to.*

How will data be collected, analyzed, and reported concerning the effect of the program/policy by racial, ethnic, gender identity, national origin, income level, disability, sexual orientation, or other existing disparities? Currently, all providers are required to enter Data into the Community Management Information System (CMIS). The data points mentioned in this question are all collected and will be used to help shape this model and its evolution. Because this is a pilot and data collection will be even more crucial to determine its efficacy, we will likely augment CMIS data entry/collection with guest/provider/community surveys during the course of this grant cycle.

How will data be collected regarding the effectiveness of this program, policy or product to ensure it is the right solution? *I believe this question has been addressed above. However, CHHS Staff, the Board and the CoC are committed to leaning into data (quantitative and qualitative) to help shape policy decisions as it concerns all programs, but especially the Housing Navigation Center model. We will be vigilant in assessing its success as the year unfolds and report back to the relevant governing/advising bodies on a regular cadence.*

Describe how this proposal aligns with current City Policies, including the Comprehensive Plan, Sustainability Action Plan, Capital Improvement Program, Neighborhood Master Plans, Council Resolutions, and others?



Community, Housing and Human Services Department (CHHS)

NOTICE OF FUNDING AVAILABILITY

Homeless, Housing, Operations, and Services (HHOS)



TABLE OF CONTENTS

REQUEST FOR PROPOSALS3
PROJECT TYPES.....3
NOFA CONTACT5
TIMELINE.....6
PERIOD OF PERFORMANCE/TERM6
ELIGIBLE APPLICANTS6
FUNDING PRIORITIES AND TARGET POPULATIONS.....6
SUBRECIPIENT RELATIONSHIP WITH THE CITY OF SPOKANE.....8
GENERAL REQUIREMENTS.....8
APPLICATION DEADLINE9
APPLICATION ASSISTANCE.....9
APPLICATION REVIEW AND RATING PROCESS.....10
GENERAL INFORMATION.....10
CONTRACT TERMS.....11

REQUEST FOR PROPOSALS

The Community, Housing and Human Services (CHHS) Department is pleased to announce a Notice of Funding Availability (NOFA) for the Housing Navigation Center Operator and Service Provider.

[Please navigate here](#) for more information on a Housing Navigation Model.

The total available for this NOFA is approximately \$3,850,000 for the period of July 1, 2024 through June 30, 2025. The funds supporting this NOFA are Washington State Department of Commerce Consolidated Homeless Grant. The City of Spokane and any subrecipients of the City of Spokane are required to adhere to funding requirements as specified by source below.

CHG/SDG- <https://deptofcommerce.app.box.com/s/9z5u4yiy7w1d19wrch6mhkeedt0o0h08>

The most competitive proposals must be able to clearly demonstrate the following:

1. Matching/leveraged funds and/or services; and
2. Clear and well thought out project scope for a collaborative system wide model; and
3. Quality of entire application packet.

PROPOSED HOUSING NAVIGATION CENTER BACKGROUND AND PURPOSE

In an effort to implement a scattered site model, relating to emergency shelter services, the City is seeking an Operator *and a separate* Primary Service Provider to provide quick and seamless access to shelter and community resources. Applicants to this RFP will be expected to have an *existing partnership* that encompasses the Operator and the Service Provider at the time of submission. Only one application will be accepted under this NOFA.

The overall approach is to move away from congregate shelter and instead support smaller and more focused emergency housing services throughout the City. The Housing Navigation Center (HNC) will serve as the first point of contact for community members experiencing homelessness and who are seeking emergency shelter and other services. The HNC will be the referral clearing house to efficiently and appropriately connect households to various emergency shelters in the City. Additionally, the City envisions the HNC as also providing limited bed space and the ability to surge during times of inclement weather.

Definitions

Housing Navigation Center (HNC): Physical location for providing connections to longer term housing and service options. Should include approximately 30 continuous stay shelter beds for individuals/couples actively seeking longer stay shelter and permanent housing options. Incorporation of a Primary (on-site) Service Provider as well as a rotation of providers brought on site to meet specific needs of the population being served leading toward stabilization prior to being referred out to the appropriate housing destination.

Operator: Agency/organization providing oversight and support for the HNC and scattered site shelter acting as the convenor and contract holder. The operator will pass funds through to the Primary Service Provider at the HNC as well as scattered site shelter operators. Additionally, the operator will facilitate the myriad of partnerships to oversee the hub (HNC) and spoke (scattered shelter) pilot for the region.

Primary Service Provider (PSP): Primary Service Provider in the HNC will manage day to day operations, compliance, and outcomes. Connecting individuals with on-site resources at the HNC as well as longer term service and housing interventions based on individual needs.

Scattered Site Shelter Operators: Manages scattered sites throughout the region serving specific populations/needs for individuals and/or couples experiencing homelessness. The focus of these locations should be to permanently house people as quickly as possible in transitional or permanent housing options.

The City recognizes the importance of identifying an Operator **who is not** currently providing direct emergency shelter services and instead can act as facilitator, supporting the PSP in effectuating their contractual duties relating to the delivery of service provision, data entry, outcomes, etc. The Operator will be the primary point of contact with the City and the PSP will maintain a subrecipient relationship with the Operator. The HNC will provide space for providers to come and directly connect to guests.

The Primary Service Provider, with oversight by the Operator, will be responsible for coordinating the variety of services needed for an individual to obtain emergency, transitional or permanent housing. Aside from directly connecting individuals to emergency housing, other services offered at the HNC should, *at minimum*, include:

- Assistance in accessing treatment services (Primary Care, Mental Health, Substance Use, Co-occurring); and
- Coordinated Entry Access; and
- Documentation gathering (photo ID/social security card); and
- Use of CMIS for enrollments into HNC and document uploads (photo ID/SS cards); and
- Connection to basic health care; and
- Connection to food and income benefits; and
- Connection to employment opportunities.
- Connection to Oxford Homes, group or adult family homes; and
- Connection to emergency or transitional housing that offer sober living.

The HNC will be responsible for managing (nightly) the current bed counts available for emergency shelter access, while noting the nuances of the subpopulation served and needs of the household. Additionally, the Operator will work with the broader community to identify pathways for existing shelters, outreach providers, and fire and police to navigate clients to scattered shelter sites.

BUDGET

AVAILABLE ACTIVITIES SUPPORTED BY THIS NOFA

- Facility Support
- Operations (Please look to the CHG Guidelines as noted below for full details on allowables)
- Administrative Costs
- Rent Assistance

Please note that the System Demonstration Grant Guidelines, updated in July of 2023, and published by the Washington Department of Commerce, set out, among other things, the requirements of what costs are allowable. It is expected and assumed, that the Grantee has thoroughly read through these Guidelines prior to submitting their proposal.

Budgets may contain all the following sections. However, not all sections are required:

Housing Navigation Center (SF 2025)	
Admin (Indirect Costs - Up to 15%)	\$ -
Facility Support	\$ -
Operations	\$ -
Rent Assistance	\$ -
TOTAL	\$ -

- Budgets can contain a maximum funding amount of \$3,850,000; of which a maximum amount of \$502,174 can be allocated to the Administrative Line for Indirect Costs.

- Administrative/Indirect Costs can be a maximum of 15% of Direct costs (Facility, Operations, and Rent Assistance). These costs are shared between the Operator and Primary Service Provider and Scattered Site Operators. A maximum of \$502,174 (when taking \$3,347,826 across all other budget categories) is allowed through the Operator and **all** subsequent contracts entered into by the Operator and the PSP and Scattered Site Operators.
- Allowable Administrative/Indirect Cost methods include Federal Negotiated Rates, Cost Allocation Plans or 10% De Minimis Rate.
 - *Important item to note: if using the De Minimis Rate, please refer to federal guidelines for allowable Direct Costs. Items such as Rent are excluded from allowable costs for De Minimis Rate.*

The Operator is expected to be fiscally secure and must show financial viability for up to 60-days should City reimbursement be delayed for any reason. The ideal Operator will have the ability to support sub-awardees with the following:

- Capacity building; and
- Technical assistance; and
- Alternate payment timelines (City will reimburse the Operator on a monthly basis); and
- Meeting space and facilitation; and
- Training; and
- Monitoring.

NOFA CONTACT

Questions related to this funding notice should be directed to the Community, Housing, and Human Services Department.

chsrfp@spokanecity.org
Spokane City Hall – 6th Floor
808 W. Spokane Falls Blvd.
Spokane, WA 99201
(509) 625-6325

PROPOSED TIMELINE

June 5, 2024	Announce RFP on CHHS department website, https://my.spokanecity.org/chhs/ , and by email distribution to the CHHS department Interested Parties List.
June 7, 2024	Optional Pre-Conference Workshop #1: Virtual 8:00 am-9:00 am
June 16, 2024	Applications DUE by 8:00 PM. Late submittals will not be accepted. ➤ Applications can be accessed and submitted <i>Printed hard copies or copies emailed in will not be accepted</i>
June 19, 2024	○ Applications reviewed by CHHS RFP committee
July 3, 2024	CHHS Board votes on RFP committee recommendations
July 8, 2024	Recommendations are taken to City Council Committee
July 22, 2024	Recommendations are at Council 1 st Reading
July 29, 2024	Recommendations are at Council for 2 nd reading and final approval
August 1, 2024	Project Start Date

PERIOD OF PERFORMANCE/TERM

Funding for this NOFA is made available through the funds listed above. The anticipated contract terms between the City of Spokane and Operator are expected to begin July 1, 2024 and extend through June 30, 2025.

ELIGIBLE APPLICANTS

Eligible applicant/recipients include:

- Governmental entities serving within the City of Spokane
- Public and private nonprofit organizations – typically 501(c)(3)
- Private for-profit organizations
- Faith-based organizations

APPLICATION SCORING

Applications will be scored on the following components:

Organizational Capability

- A. Experience and Qualifications (10 Points Max)
 - a. Experience in managing homeless services contracts; and
 - b. Demonstrated success in coordinating networks of service providers; and
 - c. Relevant certifications and qualifications of key personnel.
- B. Financial Stability (10 Points Max)
 - a. Strong financial management practices and a clear budget plan; and
 - b. Proven track record of securing and managing funds from diverse sources; and
 - c. Documentation showing 60-day solvency should City reimbursement be delayed.

Approach and Methodology

- A. Service Integration and Coordination (15 Points Max)
 - a. Comprehensive plan for integrating services across providers; and
 - b. Effective strategies for coordinating and managing scattered-site shelter services; and
- B. Capacity Building Activities (15 Points Max)
 - a. Detailed plan for capacity building activities including training, technical assistance and organizational development; and
 - b. Specific strategies for addressing the needs of small nonprofit service providers.

Compliance and Support for Strategic Plan

- A. Alignment with 2020-2025 Plan to End Homelessness (10 Points Max)
 - a. Narrative demonstrating how the applicant will comply with and support the Strategic Plan to Prevent and End Homelessness (paying close attention to the Outcomes and Measurements as it pertains to Emergency Shelter).

Data Management and Reporting (10 Points Max)

- A. History of Utilizing CMIS or Other Comparable Database
 - a. Demonstrated history of utilizing the Community Management Information System (CMIS) or other comparable database to ensure contract compliance and data timeliness.

Community Collaboration (10 Points Max)

- A. Narrative Providing concrete examples of collaboration with the community in the last year, challenges faced and how these challenges were overcome through cooperation.

Letters of Support (10 Points Max)

- A. Three Letters of Support from community organizations outlining a positive partnership history between the Operator and Primary Service Provider and why they are best suited for to manage this type of project.

Existing Partnerships (10 Points Max)

- A. Demonstrated existing partnerships with a variety of providers, including smaller organizations serving specific sub populations; DSHS; Community Centers; Spokane Housing Authority; Spokane Regional Health District, and existing shelter providers.

Referrals (10 Points Max)

- A. Plan demonstrating how the applicant will work with a variety of providers, which includes, at minimum, street outreach teams, police, fire, medical teams, to ensure fair access to the Housing Navigation Center for unsheltered households.

Performance Measurement and Evaluation (10 Points Max)

- A. Outcome Measurements and Reporting
 - a. Robust system for tracking and reporting outcomes; and
 - b. Clear metrics and indicators for evaluating success.

Financial Plan and Budget (10 Points Max)

- A. Detailed Budget (5 Points Max)
 - a. Comprehensive and realistic budget; and
 - b. Alignment of budget with proposed activities and outcomes.
- B. Cost-Effective (5 Points Max)
 - a. Efficient use of resources; and
 - b. Cost effective strategies for service delivery and capacity building.

Innovation (5 Points Max)

A. Innovative Approaches

- a. Use of innovative methods and practices in service delivery and capacity building; and
- b. Creative solutions to common challenges in homeless services.

Rating Scale

Excellent: 9-10 points

Good: 7-8 points

Satisfactory: 5-6 points

Needs Improvement: 3-4 points

Poor: 0-2 points

Total Points: 135

Excellent (121-135 points): The proposal demonstrates exceptional capability, comprehensive planning, and innovative approaches. The organization is highly qualified and likely to succeed in the role.

Good (101-120 points): The proposal is strong, with well-defined plans and adequate qualifications. Some minor improvements could be made.

Satisfactory (81-100 points): The proposal meets basic requirements but lacks depth in some areas. Additional clarification or detail is needed.

Needs Improvement (61-80 points): The proposal has several weaknesses and may not fully meet the requirements. Significant improvements are necessary.

Poor (0-60 points): The proposal does not meet the requirements and has major deficiencies.

SUBRECIPIENT RELATIONSHIP WITH THE CITY OF SPOKANE

The City of Spokane will enter into a subrecipient agreement with the Operator. The City defines a Subrecipient as an entity that receives a subaward from a pass-through entity (City of Spokane) to carry out eligible activities as defined in federal, state, or local regulatory guidance. Please see Attachment A for a graphic representation of the relationship among the City, Operator, Primary Service Provider and Scattered Site Shelter Operators.

GENERAL REQUIREMENTS

- Agencies awarded funds will maintain an active City of Spokane business license.
- Agencies awarded funds will maintain an active Universal Entity Identifier (UEI) number (see below)
- Agencies awarded funds will maintain the following minimum insurance thresholds:
 - General Liability Insurance on an occurrence basis with a combined single limit of not less than \$1,500,000.00 each occurrence for Bodily Injury and Property Damage. Supplemental umbrella insurance coverage combined with the General Liability Insurance of not less than \$1,500,000.00 each occurrence for Bodily Injury and Property Damage is also acceptable. It shall provide that the CITY, its agents, officers and employees are Additional Insureds but only with respect to the GRANTEE's services to be provided under this Agreement; and
 - Automobile Liability Insurance with a combined single limit, or the equivalent of not less than \$1,000,000.00 each accident for Bodily Injury and Property Damage, including coverage for owned, hired or non-owned vehicles.
- Agencies awarded funds will not sub-award funds to any other entity.
- **Awarded funds will be paid to Subrecipient for eligible expenses on a reimbursement basis.**

Note: Beginning on April 4, 2022, as part of the federal government’s transition for all federal awards, all entities doing business with the federal government will use the Universal Entity Identifier (UEI) assigned by the General Services Administration (GSA) through the System for Award Management (SAM.gov). Therefore, the U.S. Department of the Treasury (Treasury) will no longer be able to accept a Data Universal Numbering System (DUNS) number as a valid identification number.

What is the UEI?

Beginning April 4, 2022, the federal government will stop using the DUNS number issued by Dun & Bradstreet to uniquely identify entities. At that point, entities doing business with the federal government will use a Unique Entity Identifier (UEI) assigned in [SAM.gov](https://sam.gov) and will no longer use a third-party website to obtain their identifier. Entities are able to manage organizational information, such as legal business name and physical address associated with a UEI, directly from [SAM.gov](https://sam.gov).

What does this mean for Recipients?

No action is required if you have an existing and active registration in [SAM.gov](https://sam.gov). If you are registered in [SAM.gov](https://sam.gov), your UEI has already been assigned and is viewable in your [SAM.gov](https://sam.gov) account. Your UEI is located below the DUNS number on your entity registration record. Please ensure your legacy DUNS number is accessible in a recipient’s records for historical reference where needed, as the DUNS number will no longer be visible to users in [SAM.gov](https://sam.gov) after April 4.

New [SAM.gov](https://sam.gov) registrants will be assigned a UEI as part of their SAM registration. More information about the UEI transition is available through the U.S. General Services Administration’s [website](https://www.gsa.gov). If you are a new applicant for federal funds, you must register in SAM and obtain a UEI beginning on April 4, 2022. You may continue using your DUNS number for applications submitted prior to that date. Beginning on April 4, you will be required to list your UEI in lieu of the DUNS number on all submissions.

Again, Recipients may continue registering for and using the DUNS number up through April 3, 2022. On and after April 4, 2022, all recipients will need to apply for a UEI as part of the SAM registration process, regardless of any applications for a DUNS number pending with Dun and Bradstreet.

Where can I get more information?

Questions about the conversion from DUNS to UEI should be directed to GSA. Information about the UEI transition can be found on GSA’s webpage, [here](https://www.gsa.gov).

APPLICATION DEADLINE

Applications will be available beginning **Wednesday, June 5, 2024**, on the Community, Housing and Human Services department website <https://my.spokanecity.org/chhs/>

Application submission deadline Friday, June 16, 2024, at 8:00 PM

Applications submitted after this deadline *will not* be considered for funding.

Complete applications must be submitted electronically via chhsrfp@spokanecity.org. Incomplete applications will not be accepted. Should an agency require accommodations in how their application is submitted, please do not hesitate to reach out to the email listed above.

It is the responsibility of the applicant to be sure the proposals are submitted ahead of time. Applicants are encouraged to submit proposals in advance of Sunday, June 16, 2024 at 8:00 PM.

APPLICATION ASSISTANCE

Optional Technical Assistance workshop will be available as follows:

Optional Workshop #1

Click this link: [June 7, 2024 from 8:00 am - 9:00 am, Virtual.](#)

Or copy and paste:

https://teams.microsoft.com/l/meetup-join/19%3ameeting_ZTA5ZDJjNDgtODExMS00YzU4LWE1OWItNTQ0OTYzNTdmN2U5%40thread.v2/0?context=%7b%22Tid%22%3a%2295fa1d6e-6a27-496e-9117-fc34d9076661%22%2c%22Oid%22%3a%22d7695fcb-9c1f-4d78-ae38-0c30c23e389a%22%7d

CHHS Staff will be available to answer any questions regarding this NOFA. We encourage community partners and prospective applicants to reach out to CHHS Staff for any concerns or clarity needed as it relates to this NOFA. You may email arielleanderson@spokanecity.org for more information.

APPLICATION REVIEW AND RATING PROCESS

All applications will go through the following evaluation and review process:

Part I Initial Project Proposal Evaluations Minimum Thresholds If an application does not meet, at minimum, the following baseline threshold, it will not be sent to the CHHS RFP Committee for review and ranking:

1. Does the application answer all the NOFA questions above?
2. Has the applicant demonstrated financial viability mentioned in the NOFA?
3. Has the applicant provided a UEI number; City of Spokane Business License; Articles of Incorporation and 501(c)3 status (if non-profit) and a recent (no older than 12 months) W9 with their application?

1. Part II- Project Proposal Evaluations 135 Points Maximum

- a) The CHHS RFP Committee will review the applications based on the Application Scoring section above and the maximum scores listed per question.
 - i. Members will score, rank, and make funding recommendations.
 - ii. Forward approved recommendations to the CHHS Board and Mayor's Office for final recommendation and request for action by the Spokane City Council

2. Part II - Notice to Applicants

- a. Notice to Applicants on funding recommendation authorized by Spokane City Council on or after July 29, 2024.
- b. Applicant debriefs to unsuccessful applicants
 - i. Upon request, a debriefing conference may be scheduled with successful/unsuccessful applicants. Debriefing may be conducted in person or on the telephone.

3. Part III- Contracting

- a. Contract Creation
- b. Contract Execution

GENERAL INFORMATION

PROPRIETARY INFORMATION / PUBLIC DISCLOSURE

Materials submitted in response to this competitive process shall become the property of the City.

All applications received shall remain confidential until the award of contract recommendation has been filed with the City Clerk for City Council action. Thereafter, the Applications shall be deemed public records as defined in RCW 42.17.250 to 42.17.340, "Public Records."

Any information in the application that the applicant desires to claim as proprietary and exempt from disclosure under the provisions of state law shall be clearly designated. Each page claimed to be exempt from disclosure must be clearly identified by the word "Confidential" printed on it. Marking the entire application exempt from disclosure will not be honored.

The City will consider an applicant's request for exemption from disclosure; however, the City will make a decision predicated upon state law and regulations. If any information is marked as proprietary in the application, it will not be made available until the affected applicant has been given an opportunity to seek a court injunction against the requested disclosure.

All requests for information should be directed to the Director of CHHS, Arielle Anderson, at arielleanderson@sokanecity.org.

REVISIONS TO THE RFP

In the event it becomes necessary to revise any part of this RFP, addenda will be posted on the Community, Housing and Human Services Department website, my.spokanecity.org/CHHS. Applicants are encouraged to monitor the website for any changes and/or notifications.

The City also reserves the right to cancel or to reissue the RFP in whole or in part, prior to final award of a contract.

RESPONSIVENESS

Prior to the CHHS RFP Committee reviewing and scoring applications, they will be reviewed by the CHHS Staff to determine compliance with administrative requirements and instructions specified in this RFP. The applicant is specifically notified that failure to comply with any part of the RFP may result in rejection of the application as non-responsive.

The City reserves the right at its sole discretion to waive minor administrative irregularities.

MINORITY & WOMEN-OWNED BUSINESS PARTICIPATION

The City encourages participation in all of its contracts by firms certified by the Washington State Office of Minority and Women's Business Enterprises (OMWBE). Applicants may contact OMWBE at 360/753-9693 to obtain information on certified firms.

MOST FAVORABLE TERMS

The City reserves the right to make an award without further discussion of the application submitted. Therefore, the application should be submitted initially on the most favorable terms which the Contractor can propose. There will be no best and final offer procedure. The City does reserve the right to contact an applicant for clarification of its application.

COSTS TO MAKE APPLICATION

The City will not be liable for any costs incurred by the Applicant in preparation of an application submitted in response to this RFP, in conduct of a presentation, or any other activities related to responding to this RFP.

NO OBLIGATION TO CONTRACT

This RFP does not obligate the City to contract for services specified herein.

REJECTION OF APPLICATIONS

The City reserves the right at its sole discretion to reject any and all Applications received without penalty and to not issue a contract or grant agreement as a result of this RFP.

CONTRACT TERMS

CITY OF SPOKANE BUSINESS LICENSE

Persons / firms doing business in the City or with the City must have a valid City of Spokane business license. Questions may be directed to the Taxes and Licenses Division at (509) 625-6070.

ANTI-KICKBACK

No officer or employee of the City of Spokane, having the power or duty to perform an official act or action related to contracts resulting from this RFP shall have or acquire any interest in the contract, or have solicited, accepted or granted a present or future gift, favor, service or other thing of value from or to any person involved in the contract.

ASSIGNMENT

Agency shall not assign, transfer or subcontract its interest, in whole or in part, without the written consent of the authorizing official for the City of Spokane.

NON-WAIVER

No delay or waiver, by either party, to exercise any contractual right shall be considered as a waiver of such right or any other right.

SEVERABILITY

In the event any provision of a resulting contract should become invalid, the rest of the contract shall remain in full force and effect.

DISPUTES

Any contract resulting from this RFP shall be performed under the laws of Washington State. Any litigation to enforce said contract or any of its provisions shall be brought in Spokane County, Washington.

NONDISCRIMINATION

No individual shall be excluded from participation in, denied the benefit of, subjected to discrimination under, or denied employment in the administration of or in connection with this agreement because of age, sex, race, color, religion, creed, marital status, familial status, sexual orientation including gender expression or gender identity, national origin, honorably discharged veteran or military status, the presence of any sensory, mental or physical disability, or use of a service animal by a person with disabilities.

LIABILITY

The applicant will be considered an independent contractor and the Agency, its officers, employees, agents or subcontractors shall not be considered to be employees or agents of the City. The Agency shall defend, indemnify and hold harmless the City from all loss, liability, damage, death or injury to any person or property arising from the performance or omission of the Agency, its agents or employees, arising directly or indirectly, as a consequence of this contract.

INSURANCE

During the term of the Contract, the Company shall maintain in force at its own expense, the following insurance coverages:

A. Worker's Compensation Insurance in compliance with RCW 51.12.020 and with a limit of no less than the amount and in the form required by law, which requires subject employers to provide workers' compensation coverage for all their subject workers; and

B. General Liability Insurance on an occurrence basis, with a combined single limit of not less than \$1 million each occurrence and \$2 million general aggregate for bodily injury and property damage. It shall include contractual liability coverage for the indemnity provided under this Contract. It shall provide that the CITY, its officers and employees are additional insureds, but only with respect to GRANTEE's services to be provided under this Contract;

1. Acceptable supplementary Umbrella insurance coverage, combined with GRANTEE's General Liability insurance policy must be a minimum of \$1,000,000, in order to meet the insurance coverages required under this Contract;

C. Automobile Liability Insurance with a combined single limit, or the equivalent of not less than \$1,000,000 each accident for bodily injury and property damage, including coverage for owned, hired and non-owned vehicles.

INTERNAL AUDITING CONTROL

The Agency shall establish and maintain a system of internal accounting control which complies with applicable generally accepted accounting principles and governmental accounting and financial reporting standards. A copy of the Agency's most

recent audited financial statement shall be kept on file in the Community, Housing and Human Services Department. The City has the right to supervise and audit the finances of the Agency to ensure that actual expenditures remain consistent with the spirit and intent of any contract resulting from this RFP. The City of Spokane and/or its funding agencies and auditors may inspect and audit all records and other materials and the Agency shall make such available upon request.

AMERICANS WITH DISABILITIES ACT (ADA) INFORMATION: The City of Spokane is committed to providing equal access to its facilities, programs, and services for persons with disabilities. Individuals requesting reasonable accommodations or further information may call, write, or email Christine Cavanaugh at (509) 625-6383, 808 West Spokane Falls Boulevard, Spokane, Washington, 99201; or ccavanaugh@spokanecity.org. Persons who are deaf or hard of hearing may contact Ms. Kris Smith at (509) 625-6383 through the Washington Relay Service at 7-1-1. Please contact the City forty-eight (48) hours before the meeting date.

EQUAL CREDIT OPPORTUNITY ACT INFORMATION: The federal Equal Credit Opportunity Act (ECOA), 15 U.S.C. 1691 et seq., prohibits creditors from discriminating against credit applicants on the basis of race, color, religion, national origin, sex or marital status, or age (provided the applicant has the capacity to contract); because all or part of the applicant's income derives from any public assistance program; or because the applicant has in good faith exercised any right under the Consumer Credit Protection Act. The federal agency that administers compliance with this law concerning this creditor is the Consumer Response Center, Federal Trade Commission, 600 Pennsylvania Ave, NW, Washington, D.C. 20580. For information regarding the ECOA, see http://www.justice.gov/crt/about/hce/housing_ecoa.php.

EQUAL HOUSING OPPORTUNITY INFORMATION: The City is pledged to the letter and spirit of U.S. policy for the achievement of equal housing opportunity throughout the Nation. The City encourages and supports an affirmative advertising and marketing program in which there are no barriers to obtaining housing because of race, color, religion, sex, handicap, familial status, or national origin.

WASHINGTON LAW AGAINST DISCRIMINATION INFORMATION: We do business in accordance with the Washington Law Against Discrimination, RCW 49.60, which prohibits discrimination on the basis of race, color, creed, national origin, disability, HIV/Aids and Hepatitis C status, use of guide dog or service animal, sex, marital status, age (employment only), families with children (housing only), sexual orientation/gender identity, and honorably discharged veteran or military status.

→ DENOTES FUNDING STREAM

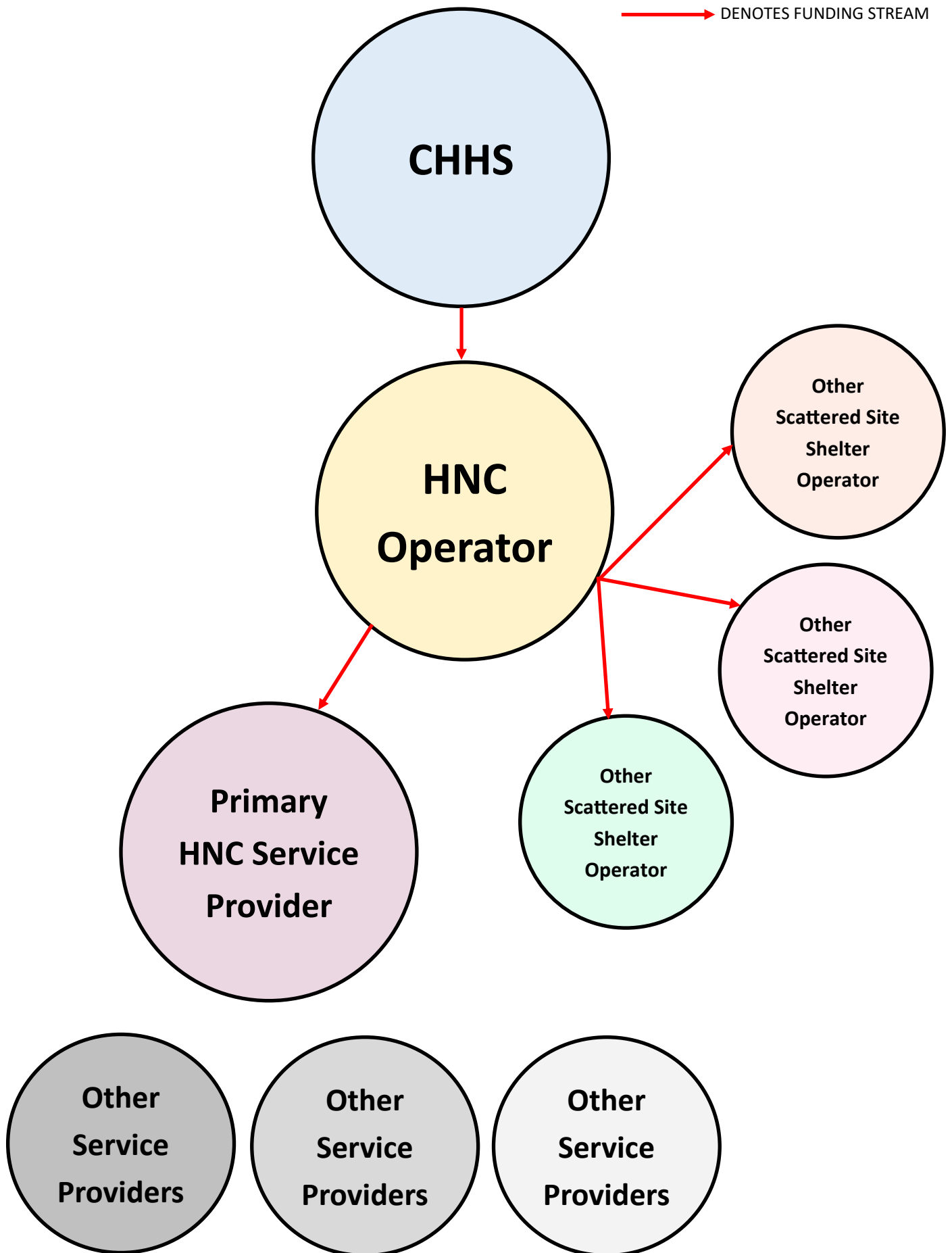

RFP Section	Domain/ Criteria	Evidence	#1	#2	#3	#4	#5	#6
Organizational Capability	Experience and Qualifications		10	10	10	10	10	10
		Experience in managing homeless services	3		4	2	3	3
		Demonstrated success in coordinating networks of service providers	4		3	3	3	3
		Relevant certifications and qualifications of key personnel	3		3	3	3	2
	Financial Stability and Management		10	9	10	8	10	10
		Strong financial management practices and a clear budget plan	5		4	5	5	3
	Proven track record of securing and managing funds from diverse sources	5		5	4	5	4	
Approach and Methodology	Service Integration and Coordination		15	13	15	9	15	15
		Comprehensive plan for integrating services across providers	5		7	6	8	6
		Effective strategies for coordinating and managing scattered-site shelter services	3		7	6	4	6
	Capacity-Building Activities		15	14	15	12	15	15
		Detailed plan for capacity-building activities including training, technical assistance, and organizational development	5		8	4	10	6
		Specific strategies for addressing the needs of small nonprofit service providers	10		7	4	3	7
Compliance and Support for Strategic Plan	Alignment with Spokane City/Spokane County 2020-2025 Strategic Plan		10	10	10	8	10	10
		Narrative demonstrating how the applicant will comply with and support the Strategic Plan to Prevent and End Homelessness	10		10	6	10	9
Data Management and Reporting	History of Utilizing CMIS		10	10	10	6	10	10
		Demonstrated history of utilizing the Community Management Information System (CMIS) to ensure contract compliance and data timeliness	10		10	7	10	8
Community Collaboration	Community Collaboration		10	8	10	7	10	10
		Narrative providing concrete examples of collaboration with the community in the last year, challenges faced, and how these challenges were overcome through cooperation	10		9	6	10	8
Letters of Support	Letters of Support		10	7	10	6	10	10
		Three Letters of Support from community organizations outlining a positive partnership history and why the applicant is best suited for this role	10		10	7	10	7
Existing Partnerships	Existing Partnerships		10	8	10	7	10	10
		Demonstrated existing partnerships with a variety of providers, including smaller organizations serving specific sub-populations, DSHS, Community Centers, Spokane Housing Authority, Spokane Regional Health District, and existing shelter providers	10		10	5	8	9
Referrals	Access to Housing Navigation Center		10	10	10	5	10	10
		Plan demonstrating how the applicant will work with a variety of providers, which includes, at minimum, street outreach and medical teams, police, fire, etc., to ensure fair and equal access.	5		10	5	10	9
Performance Measurement and Evaluation	Outcome Measurement and Reporting		10	9	10	5	10	10
		Robust system for tracking and reporting outcomes.	5		5	2	4	5
		Clear metrics and indicators for evaluating success	5		5	2	6	4
Financial Plan and Budget	Detailed Budget		5	4	5	4	5	5
		Comprehensive and realistic budget	1		2	2	2	1
		Alignment of budget with proposed activities and outcomes	3		3	2	3	2
	Cost-Effective		5	2	5	4	5	5
		Efficient use of resources	2		3	2	3	1
	Cost-effective strategies for service delivery and capacity building	2		2	2	2	1	
Innovation	Innovative Approaches		5	5	5	4	5	5
		Use of innovative methods and practices in service delivery and capacity building	2		3	2	3	2
		Creative solutions to common challenges in homeless services	3		2	2	2	2
AVERAGE SCORE: (101-120=good)	115	TOTAL (must not exceed 135):	121	119	132	89	127	108

#1	
10	
5	
4	
1	
10	
6	
4	
15	
9	
5	
15	
8	
5	
10	
6	
10	
5	
7	
10	
10	
8	
10	
10	
10	
10	
10	
3	
3	
5	
2	
1	
5	
1	
1	
5	
2	
2	
111	



Agenda Sheet for City Council:

Committee: Finance & Administration **Date:** 07/22/2024

Committee Agenda type: Consent

Date Rec'd 7/24/2024

Clerk's File # OPR 2024-0610

Cross Ref #

Project #

Council Meeting Date: 08/12/2024

Submitting Dept	FINANCE, TREASURY & ADMIN	Bid #	
------------------------	---------------------------	--------------	--

Contact Name/Phone	MATT BOSTON 625-6820	Requisition #	CR26490
---------------------------	----------------------	----------------------	---------

Contact E-Mail	MBOSTON@SPOKANECITY.ORG		
-----------------------	-------------------------	--	--

Agenda Item Type	Contract Item		
-------------------------	---------------	--	--

Council Sponsor(s)	BWILKERSON MCATHCART ZZAPPONE		
---------------------------	-------------------------------	--	--

Agenda Item Name	0410- CONTRACT WITH GARTNER, INC.		
-------------------------	-----------------------------------	--	--

Agenda Wording

Advisory and Technology research subscription for Finance Department leadership

Summary (Background)

The Finance division would like to contract with Gartner, Inc. for a consulting service contract for technology research and advisory for Finance leadership. Contact was procured through DES master contract 08321. (NASPO 186840)

Lease? NO Grant related? NO Public Works? NO

Fiscal Impact

Approved in Current Year Budget? YES

Total Cost	\$ 150,128
------------	------------

Current Year Cost	\$ 150,128
-------------------	------------

Subsequent Year(s) Cost	\$
-------------------------	----

Narrative

Amount	Budget Account
Expense \$ 150,128	# 0410-34100-14230-54201-99999 before sales tax
Select \$	#
Select \$	#
Select \$	#
\$	#
\$	#

Committee Briefing Paper

Finance & Administration Committee

Committee Date	7/22/2024
Submitting Department	Finance
Contact Name	Matt Boston
Contact Email & Phone	mboston@spokanecity.org 509-625-6820
Council Sponsor(s)	Cathcart, Zappone, Wilkerson
Select Agenda Item Type	<input checked="" type="checkbox"/> Consent <input type="checkbox"/> Discussion Time Requested:
Agenda Item Name	0410 – Contract with Gartner Inc
Proposed Council Action	<input checked="" type="checkbox"/> Approval to proceed to Legislative Agenda <input type="checkbox"/> Information Only
Summary (Background)	The Finance division would like to contract with Gartner Inc for consulting service contract for technology research and advisory for Finance leadership. *use the Fiscal Impact box below for relevant financial information
	Contact was procured through DES master contract 08321. (NASPO 186840)
Fiscal Impact	
Approved in current year budget? <input checked="" type="checkbox"/> Yes <input type="checkbox"/> No <input type="checkbox"/> N/A	
Total Cost: <u>150,128.00</u>	
Current year cost: \$150,128.00	
Subsequent year(s) cost: n/a	
Narrative: Please provide financial due diligence review, as applicable, such as number and type of positions, grant match requirements, summary type details (personnel, maintenance and supplies, capital, revenue), impact on rates, fees, or future shared revenue	
Funding Source <input type="checkbox"/> One-time <input checked="" type="checkbox"/> Recurring <input type="checkbox"/> N/A	
Specify funding source: Program revenue	
Is this funding source sustainable for future years, months, etc? Yes	
Expense Occurrence <input type="checkbox"/> One-time <input checked="" type="checkbox"/> Recurring <input type="checkbox"/> N/A	
Other budget impacts: (revenue generating, match requirements, etc.)	
Operations Impacts (If N/A, please give a brief description as to why)	
<ul style="list-style-type: none"> • What impacts would the proposal have on historically excluded communities? None Identified • How will data be collected, analyzed, and reported concerning the effect of the program/policy by racial, ethnic, gender identity, national origin, income level, disability, sexual orientation, or other existing disparities? Data will not be collected. • How will data be collected regarding the effectiveness of this program, policy, or product to ensure it is the right solution? Consultation services are designed to improve knowledge and experience of staff and provide suggestions for possible options based on subject matter discussed. 	

- Describe how this proposal aligns with current City Policies, including the Comprehensive Plan, Sustainability Action Plan, Capital Improvement Program, Neighborhood Master Plans, Council Resolutions, and others? Complies with City policy for procurement and contracting. Research and consulting will help City refine plans to help with operational efficiencies.

Council Subcommittee Review

- Please provide a summary of council subcommittee review. If not reviewed by a council subcommittee, please explain why not.



City of Spokane
CONSULTANT AGREEMENT
Title: CONSULTING, RESEARCH AND RELATED SERVICES

This Consultant Agreement is made and entered into by and between the **CITY OF SPOKANE** as (“City”), a Washington municipal corporation, and **GARTNER, INC.**, whose address is 56 Top Gallant Road, Stamford, Connecticut 06902 as (“Consultant”), individually hereafter referenced as a “party”, and together as the “parties”.

WHEREAS, the purpose of this Agreement is for Consultant to provide Consulting, Research and Related Services to City as Consultant’s Client; and

WHEREAS, the Consultant was selected utilizing DES 08321 - NASPO/ValuePoint Contract #: 186840.

NOW, THEREFORE, in consideration of the terms, conditions, covenants and performance of the Scope of Work contained herein, the City and Consultant mutually agree as follows:

1. TERM OF AGREEMENT.

The term of this Agreement begins on August 12, 2024, and ends on September 30, 2025, unless amended by written agreement or terminated earlier under the provisions.

2. TIME OF BEGINNING AND COMPLETION.

The Consultant shall begin the work outlined in the “Scope of Work” (“Work”) on the beginning date, above. The City will acknowledge in writing when the Work is complete. Time limits established under this Agreement shall not be extended because of delays for which the Consultant is responsible, but may be extended by the City, in writing, for the City’s convenience or conditions beyond the Consultant’s control.

3. SCOPE OF WORK.

The General Scope of Work for this Agreement is described in the Consultant’s Service Agreement, attached as Exhibit B. In the event of a conflict or discrepancy in the contract documents, this City Agreement controls.

The Work is subject to City review and approval. The Consultant shall confer with the City periodically, and prepare and present information and materials (e.g. detailed outline of completed Work) requested by the City to determine the adequacy of the Work or Consultant’s progress.

4. COMPENSATION.

Total compensation for Consultant's services under this Agreement shall not exceed **ONE HUNDRED FIFTY THOUSAND ONE HUNDRED TWENTY-EIGHT AND NO/100 DOLLARS (\$150,128.00)**, excluding tax, if applicable, unless modified by a written amendment to this Agreement. This is the maximum amount to be paid under this Agreement for the work described in Section 3 above, and shall not be exceeded without the prior written authorization of the City in the form of an executed amendment to this Agreement.

5. PAYMENT.

The Consultant shall submit its applications for payment electronically, in PDF format to dtyurin@spokanecity.org. **Payment will be made via direct deposit/ACH** within thirty (30) days after receipt of the Consultant's application except as provided by state law. If the City objects to all or any portion of the invoice, it shall notify the Consultant and pay that portion of the invoice not in dispute. In that event, the parties shall immediately make every effort to settle the disputed amount.

6. REIMBURSABLES

The reimbursables under this Agreement are to be included, and considered part of the maximum amount not to exceed (above), and require the Consultant's submittal of appropriate documentation and actual itemized receipts, the following limitations apply.

- A. City will reimburse the Consultant at actual cost for expenditures that are pre-approved by the City in writing and are necessary and directly applicable to the work required by this Contract provided that similar direct project costs related to the contracts of other clients are consistently accounted for in a like manner. Such direct project costs may not be charged as part of overhead expenses or include a markup. Other direct charges may include, but are not limited to the following types of items: travel, printing, cell phone, supplies, materials, computer charges, and fees of subconsultants.
- B. The billing for third party direct expenses specifically identifiable with this project shall be an itemized listing of the charges supported by copies of the original bills, invoices, expense accounts, subconsultant paid invoices, and other supporting documents used by the Consultant to generate invoice(s) to the City. The original supporting documents shall be available to the City for inspection upon request. All charges must be necessary for the services provided under this Contract.
- C. **Miscellaneous other business expenses** (e.g. printing, photo development, binding): Other miscellaneous business expenses will be reimbursed at the actual cost incurred and may not include a markup. Receipts are required for all miscellaneous expenses that are billed.

Subconsultant: Subconsultant expenses will be reimbursed at the actual cost incurred and a four percent (4%) markup. Copies of all Subconsultant invoices that are rebilled to the City are required.

7. TAXES, FEES AND LICENSES.

- A. Consultant shall pay and maintain in current status, all necessary licenses, fees, assessments, permit charges, etc. necessary to conduct the work included under this Agreement. It is the Consultant's sole responsibility to monitor and determine changes or the enactment of any subsequent requirements for said fees, assessments, or changes and to immediately comply.
- B. Where required by state statute, ordinance or regulation, Consultant shall pay and maintain in current status all taxes necessary for performance. Consultant shall not charge the City

for federal excise taxes. The City will furnish Consultant an exemption certificate where appropriate.

- C. The Director of Finance and Administrative Services may withhold payment pending satisfactory resolution of unpaid taxes and fees due the City.
- D. The cost of any permits, licenses, fees, etc. arising as a result of the projects included in this Agreement shall be included in the project budgets.

8. CITY OF SPOKANE BUSINESS LICENSE.

Section 8.01.070 of the Spokane Municipal Code states that no person may engage in business with the City without first having obtained a valid annual business registration. The Consultant shall be responsible for contacting the State of Washington Business License Services at www.dor.wa.gov or 360-705-6741 to obtain a business registration. If the Contractor does not believe it is required to obtain a business registration, it may contact the City's Taxes and Licenses Division at (509) 625-6070 to request an exemption status determination.

9. SOCIAL EQUITY REQUIREMENTS.

No individual shall be excluded from participation in, denied the benefit of, subjected to discrimination under, or denied employment in the administration of or in connection with this Agreement because of age, sex, race, color, religion, creed, marital status, familial status, sexual orientation including gender expression or gender identity, national origin, honorably discharged veteran or military status, the presence of any sensory, mental or physical disability, or use of a service animal by a person with disabilities. Consultant agrees to comply with, and to require that all subcontractors comply with, Section 504 of the Rehabilitation Act of 1973 and the Americans with Disabilities Act, as applicable to the Consultant. Consultant shall seek inclusion of woman and minority business for subcontracting. A woman or minority business is one that self-identifies to be at least 51% owned by a woman and/or minority. Such firms do not have to be certified by the State of Washington.

10. INDEMNIFICATION.

The Consultant shall indemnify, and hold the City and its officers and employees harmless from all claims, demands, or suits at law or equity asserted by third parties for bodily injury (including death) and/or property damage to the extent caused by the Consultant's negligence or willful misconduct under this Agreement, including attorneys' fees and litigation costs; provided that nothing herein shall require a Consultant to indemnify the City against and hold harmless the City from claims, demands or suits based solely upon the negligence of the City, its agents, officers, and employees. If a claim or suit is caused by or results from the concurrent negligence of the Consultant's agents or employees and the City, its agents, officers and employees, this indemnity provision shall be valid and enforceable to the extent of the negligence of the Consultant, its agents or employees. The Consultant specifically assumes liability and agrees to defend, indemnify, and hold the City harmless for actions brought by the Consultant's own employees against the City and, solely for the purpose of this indemnification and defense, the Consultant specifically waives any immunity under the Washington State industrial insurance law, or Title 51 RCW. The Consultant recognizes that this waiver was specifically entered into pursuant to the provisions of RCW 4.24.115 and was the subject of mutual negotiation. The indemnity and agreement to defend and hold the City harmless provided for in this section shall survive any termination or expiration of this agreement.

11. LIMITATION OF LIABILITY

Neither party shall be liable for any consequential, indirect, special or incidental damages, such as damages for lost profits, business failure or loss arising out of use of the Deliverables or the Services, whether or not advised of the possibility of such damages. Except for liability for

personal injury or death or for damage to property caused by the negligence or willful misconduct of Consultant or its employees, Consultant's total liability arising out of this Agreement and the provision of the Services shall be limited to the fees paid by the City under the specific Statement of Work or Service Agreement under which such liability arises.

12. INSURANCE.

During the period of the Agreement, the Consultant shall maintain in force at its own expense, each insurance noted below with companies or through sources approved by the State Insurance Commissioner pursuant to RCW Title 48;

A. Worker's Compensation Insurance in compliance with RCW 51.12.020, which requires subject employers to provide workers' compensation coverage for all their subject workers and Employer's Liability Insurance in the amount of \$1,000,000;

B. General Liability Insurance on an occurrence basis, with a combined single limit of not less than \$1,000,000 each occurrence for bodily injury and property damage. It shall include contractual liability coverage for the indemnity provided under this agreement. It shall provide that the City, its officers and employees are additional insureds but only with respect to the Consultant's services to be provided under this Agreement; and

C. Automobile Liability Insurance with a combined single limit, or the equivalent of not less than \$1,000,000 each accident for bodily injury and property damage, including coverage for owned, hired and non-owned vehicles.

D. Professional Liability Insurance with a combined single limit of not less than \$1,000,000 each claim, incident or occurrence. This is to cover damages caused by the error, omission, or negligent acts related to the professional services to be provided under this Agreement. The coverage must remain in effect for at least two (2) years after the Agreement is completed.

There shall be no cancellation, material change, reduction of limits or intent not to renew the insurance coverage(s) without thirty (30) days written notice from the Consultant or its insurer(s) to the City. As evidence of the insurance coverage(s) required by this Agreement, the Consultant shall furnish acceptable Certificates Of Insurance (COI) to the City at the time it returns this signed Agreement. The certificate shall specify the City of Spokane as "Additional Insured" specifically for Consultant's services under this Agreement, as well as all of the parties who are additional insureds, and include applicable policy endorsements, the thirty (30) day cancellation clause, and the deduction or retention level. The Consultant shall be financially responsible for all pertinent deductibles, self-insured retentions, and/or self-insurance.

13. DEBARMENT AND SUSPENSION.

The Consultant has provided its certification that it is in compliance with and shall not contract with individuals or organizations which are debarred, suspended, or otherwise excluded from or ineligible from participation in Federal Assistance Programs under Executive Order 12549 and "Debarment and Suspension", codified at 29 CFR part 98.

14. AUDIT.

Upon request, the Consultant shall permit the City and any other governmental agency ("Agency") involved in the funding of the Work to inspect and audit all pertinent books and records. This includes work of the Consultant, any subconsultant, or any other person or entity that performed connected or related Work. Such books and records shall be made available upon reasonable notice of a request by the City, including up to three (3) years after final payment or release of withheld amounts. Such inspection and audit shall occur in Spokane

County, Washington, or other reasonable locations mutually agreed to by the parties. The Consultant shall permit the City to copy such books and records at its own expense. The Consultant shall ensure that inspection, audit and copying rights of the City is a condition of any subcontract, agreement or other arrangement under which any other persons or entity may perform Work under this Agreement.

15. INDEPENDENT CONSULTANT.

- A. The Consultant is an independent Consultant. This Agreement does not intend the Consultant to act as a City employee. The City has neither direct nor immediate control over the Consultant nor the right to control the manner or means by which the Consultant works. Neither the Consultant nor any Consultant employee shall be an employee of the City. This Agreement prohibits the Consultant to act as an agent or legal representative of the City. The Consultant is not granted express or implied rights or authority to assume or create any obligation or responsibility for or in the name of the City, or to bind the City. The City is not liable for or obligated to pay sick leave, vacation pay, or any other benefit of employment, nor to pay social security or other tax that may arise from employment. The Consultant shall pay all income and other taxes as due. The Consultant may perform work for other parties; the City is not the exclusive user of the services that the Consultant provides.
- B. If the City needs the Consultant to Work on City premises and/or with City equipment, the City may provide the necessary premises and equipment. Such premises and equipment are exclusively for the Work and not to be used for any other purpose.
- C. If the Consultant works on the City premises using City equipment, the Consultant remains an independent Consultant and not a City employee. The Consultant will notify the City Project Manager if s/he or any other Workers are within ninety (90) days of a consecutive 36-month placement on City property. If the City determines using City premises or equipment is unnecessary to complete the Work, the Consultant will be required to work from its own office space or in the field. The City may negotiate a reduction in Consultant fees or charge a rental fee based on the actual costs to the City, for City premises or equipment.

16. KEY PERSONS.

The Consultant shall not transfer or reassign any individual designated in this Agreement as essential to the Work, nor shall those key persons, or employees of Consultant identified as to be involved in the Project Work be replaced, removed or withdrawn from the Work without the express written consent of the City, which shall not be unreasonably withheld. If any such individual leaves the Consultant's employment, the Consultant shall present to the City one or more individuals with greater or equal qualifications as a replacement, subject to the City's approval, which shall not be unreasonably withheld. The City's approval does not release the Consultant from its obligations under this Agreement.

17. ASSIGNMENT AND SUBCONTRACTING.

The Consultant shall not assign or subcontract its obligations under this Agreement without the City's written consent, which may be granted or withheld in the City's sole discretion. Any subcontract made by the Consultant shall incorporate by reference this Agreement, except as otherwise provided. The Consultant shall require that all subconsultants comply with the obligations and requirements of the subcontract. The City's consent to any assignment or subcontract does not release the consultant from liability or any obligation within this Agreement, whether before or after City consent, assignment or subcontract.

18. CITY ETHICS CODE.

- A. Consultant shall promptly notify the City in writing of any person expected to be a Consultant Worker (including any Consultant employee, subconsultant, principal, or owner) and was a former City officer or employee within the past twelve (12) months.
- B. Consultant shall ensure compliance with the City Ethics Code by any Consultant Worker when the Work or matter related to the Work is performed by a Consultant Worker who has been a City officer or employee within the past two (2) years.
- C. Consultant shall not directly or indirectly offer anything of value (such as retainers, loans, entertainment, favors, gifts, tickets, trips, favors, bonuses, donations, special discounts, work or meals) to any City employee, volunteer or official that is intended, or may appear to a reasonable person to be intended, to obtain or give special consideration to the Consultant. Promotional items worth less than \$25 may be distributed by the Consultant to a City employee if the Consultant uses the items as routine and standard promotional materials. Any violation of this provision may cause termination of this Agreement. Nothing in this Agreement prohibits donations to campaigns for election to City office, so long as the donation is disclosed as required by the election campaign disclosure laws of the City and of the State.

19. NO CONFLICT OF INTEREST.

Consultant confirms that the Consultant or workers have no business interest or a close family relationship with any City officer or employee who was or will be involved in the consultant selection, negotiation, drafting, signing, administration or evaluation of the Consultant's work. As used in this Section, the term Consultant includes any worker of the Consultant who was, is, or will be, involved in negotiation, drafting, signing, administration or performance of the Agreement. The term "close family relationship" refers to: spouse or domestic partner, any dependent parent, parent-in-law, child, son-in-law, daughter-in-law; or any parent, parent in-law, sibling, uncle, aunt, cousin, niece or nephew residing in the household of a City officer or employee described above.

20. ERRORS AND OMISSIONS, CORRECTIONS.

Consultant is responsible for professional quality, technical accuracy, and the coordination of all designs, drawings, specifications, and other services furnished by or on the behalf of the Consultant under this Agreement in the delivery of a final work product. The standard of care applicable to Consultant's services will be the degree of skill and diligence normally employed by professional engineers or Consultants performing the same or similar services at the time said services are performed. The Final Work Product is defined as a stamped, signed work product. Consultant, without additional compensation, shall correct or revise errors or mistakes in designs, drawings, specifications, and/or other consultant services immediately upon notification by the City. The obligation provided for in this Section regarding acts or omissions resulting from this Agreement survives Agreement termination or expiration.

21. INTELLECTUAL PROPERTY RIGHTS.

Consultant owns and retains all rights to the Services not expressly granted to the City. Only the individuals named in the Service Agreement (each a "Licensed User") may access the Services. Each Licensed User will be issued a unique password, which may not be shared. The City agrees to review and comply with the Consultant Usage Policy, which is accessible to all Licensed Users via the "Policies" section of gartner.com. Among other things, the Consultant Usage Policy describes how the City may substitute Licensed Users, excerpt from and/or share Consultant research documents within the City, and quote or excerpt from the Services externally.

22. DISCLAIMER OF WARRANTIES.

THE SERVICES ARE PROVIDED ON AN "AS IS" BASIS, AND CONSULTANT EXPRESSLY DISCLAIMS ALL WARRANTIES, EXPRESS OR IMPLIED, STATUTORY OR OTHERWISE, INCLUDING, WITHOUT LIMITATION, ANY IMPLIED WARRANTIES OF FITNESS FOR A PARTICULAR PURPOSE OR AS TO ACCURACY, COMPLETENESS OR ADEQUACY OF INFORMATION. THE CITY RECOGNIZES THE UNCERTAINTIES INHERENT IN ANY ANALYSIS OR INFORMATION THAT MAY BE PROVIDED AS PART OF THE SERVICES, AND ACKNOWLEDGES THAT THE SERVICES ARE NOT A SUBSTITUTE FOR ITS OWN INDEPENDENT EVALUATION AND ANALYSIS AND SHOULD NOT BE CONSIDERED A RECOMMENDATION TO PURSUE ANY COURSE OF ACTION. CONSULTANT SHALL NOT BE LIABLE FOR ANY ACTIONS OR DECISIONS THAT THE CITY MAY TAKE BASED ON THE SERVICES OR ANY INFORMATION OR DATA CONTAINED THEREIN. THE CITY UNDERSTANDS THAT IT ASSUMES THE ENTIRE RISK WITH RESPECT TO THE USE OF THE SERVICES.

23. CONFIDENTIALITY.

Notwithstanding anything to the contrary, City will maintain the confidentiality of Consultant's materials and information only to the extent that is legally allowed in the State of Washington. City is bound by the State Public Records Act, RCW Ch. 42.56. That law presumptively makes all records in the possession of the City public records which are freely available upon request by anyone. In the event that City gets a valid public records request for Consultant's materials or information and the City determines there are exemptions only the Consultant can assert, City will endeavor to give Consultant notice. Consultant will be required to go to Court to get an injunction preventing the release of the requested records. In the event that Consultant does not get a timely injunction preventing the release of the records, the City will comply with the Public Records Act and release the records.

24. DISPUTES.

Any dispute or misunderstanding that may arise under this Agreement, concerning the Consultant's performance, shall first be through negotiations, if possible, between the Consultant's Project Manager and the City's Project Manager. It shall be referred to the Director and the Consultant's senior executive(s). If such officials do not agree upon a decision within a reasonable period of time, either party may decline or discontinue such discussions and may then pursue the legal means to resolve such disputes, including but not limited to mediation, arbitration and/or alternative dispute resolution processes. Nothing in this dispute process shall mitigate the rights of the City to terminate the Agreement. Notwithstanding all of the above, if the City believes in good faith that some portion of the Work has not been completed satisfactorily, the City may require the Consultant to correct such work prior to the City payment. The City will provide to the Consultant an explanation of the concern and the remedy that the City expects. The City may withhold from any payment otherwise due, an amount that the City in good faith finds to be under dispute, or if the Consultant provides no sufficient remedy, the City may retain the amount equal to the cost to the City for otherwise correcting or remedying the work not properly completed. Waiver of any of these rights is not deemed a future waiver of any such right or remedy available at law, contract or equity.

25. TERMINATION.

A. For Cause: The City or Consultant may terminate the Agreement if the other party is in material breach of this Agreement, and such breach has not been corrected to the other party's reasonable satisfaction in a timely manner. Notice of termination under this Section

shall be given by the party terminating this Agreement to the other, not fewer than thirty (30) business days prior to the effective date of termination.

- B. For Reasons Beyond Control of Parties: Either party may terminate this Agreement without recourse by the other where performance is rendered impossible or impracticable for reasons beyond such party's reasonable control, such as, but not limited to, an act of nature, war or warlike operation, civil commotion, riot, labor dispute including strike, walkout or lockout, except labor disputes involving the Consultant's own employees, sabotage, or superior governmental regulation or control. Notice of termination under this Section shall be given by the party terminating this Agreement to the other, not fewer than thirty (30) business days prior to the effective date of termination.
- C. For Convenience: Either party may terminate this Agreement without cause, upon thirty (30) days written notice to the other party.
- D. Actions upon Termination: if termination occurs not the fault of the Consultant, the Consultant shall be paid for the services properly performed prior to the actual termination date, with any reimbursable expenses then due, but such compensation shall not exceed the maximum compensation to be paid under the Agreement. The Consultant agrees this payment shall fully and adequately compensate the Consultant and all subconsultants for all profits, costs, expenses, losses, liabilities, damages, taxes and charges of any kind (whether foreseen or unforeseen) attributable to the termination of this Agreement.
- E. Upon termination, the Consultant shall provide the City with the most current design documents, contract documents, writings and other products the Consultant has produced to termination, along with copies of all project-related correspondence and similar items. The City shall have the same rights to use these materials as if termination had not occurred; provided however, that the City shall indemnify and hold the Consultant harmless from any claims, losses, or damages to the extent caused by modifications made by the City to the Consultant's work product.

26. EXPANSION FOR NEW WORK.

This Agreement scope may be expanded for new work. Any expansion for New Work (work not specified within the original Scope of Work Section of this Agreement, and/or not specified in the original RFP as intended work for the Agreement) must comply with all the following limitations and requirements: (a) the New Work is not reasonable to solicit separately; (b) the New Work is for reasonable purpose; (c) the New Work was not reasonably known to either the City or Consultant at time of contract or else was mentioned as a possibility in the solicitation (such as future phases of work, or a change in law); (d) the New Work is not significant enough to be reasonably regarded as an independent body of work; (e) the New Work would not have attracted a different field of competition; and (f) the change does not vary the essential identified or main purposes of the Agreement. The City may make exceptions for immaterial changes, emergency or sole source conditions, or other situations required in City opinion. Certain changes are not New Work subject to these limitations, such as additional phases of Work anticipated at the time of solicitation, time extensions, Work Orders issued on an On-Call contract, and similar. New Work must be mutually agreed and issued by the City through written Addenda. New Work performed before an authorizing Amendment may not be eligible for payment.

27. MISCELLANEOUS PROVISIONS.

- A. Amendments: No modification of this Agreement shall be effective unless in writing and signed by an authorized representative of each of the parties hereto.

- B. Binding Agreement: This Agreement shall not be binding until signed by both parties. The provisions, covenants and conditions in this Agreement shall bind the parties, their legal heirs, representatives, successors and assigns.
- C. Americans with Disabilities Act (ADA): Specific attention by the designer is required in association with the Americans with Disabilities Act (ADA) 42 U.S.C. 12101-12213 and 47 U.S.C. 225 and 611, its requirements, regulations, standards and guidelines, which were updated in 2010 and are effective and mandatory for all State and local government facilities and places of public accommodation for construction projects including alteration of existing facilities, as of March 15, 2012. The City advises that the requirements for accessibility under the ADA, may contain provisions that differ substantively from accessibility provisions in applicable State and City codes, and if the provisions of the ADA impose a greater or equal protection for the rights of individuals with disabilities or individuals associated with them than the adopted local codes, the ADA prevail unless approval for an exception is obtained by a formal documented process. Where local codes provide exceptions from accessibility requirements that differ from the ADA Standards; such exceptions may not be permitted for publicly owned facilities subject to Title II requirements unless the same exception exists in the Title II regulations. It is the responsibility of the designer to determine the code provisions.
- D. The Consultant, at no expense to the City, shall comply with all laws of the United States and Washington, the Charter and ordinances of the City of Spokane; and rules, regulations, orders and directives of their administrative agencies and officers. Without limiting the generality of this paragraph, the Consultant shall comply with the requirements of this Section.
- E. This Agreement shall be construed and interpreted under the laws of Washington. The venue of any action brought shall be in the Superior Court of Spokane County.
- F. Remedies Cumulative: Rights under this Agreement are cumulative and nonexclusive of any other remedy of law or in equity.
- G. Captions: The titles of sections or subsections are for convenience only and do not define or limit the contents.
- H. Severability: If any term or provision is determined by a court of competent jurisdiction to be invalid or unenforceable, the remainder of this Agreement shall not be affected, and each term and provision shall be valid and enforceable to the fullest extent permitted by law.
- I. Waiver: No covenant, term or condition or the breach shall be deemed waived, except by written consent of the party against whom the waiver is claimed, and any waiver of the breach of any covenant, term or condition shall not be deemed a waiver of any preceding or succeeding breach of the same or any other covenant, term of condition. Neither the acceptance by the City of any performance by the Consultant after the time the same shall have become due nor payment to the Consultant for any portion of the Work shall constitute a waiver by the City of the breach or default of any covenant, term or condition unless otherwise expressly agreed to by the City in writing.
- J. Additional Provisions: This Agreement may be modified by additional terms and conditions ("Special Conditions") which shall be attached to this Agreement as an Exhibit. The parties agree that the Special Conditions shall supplement the terms and conditions of the Agreement, and in the event of ambiguity or conflict with the terms and conditions of the Agreement, these Special Conditions shall govern.
- K. Entire Agreement: This document along with any exhibits and all attachments, and subsequently issued addenda, comprises the entire agreement between the City and the Consultant. If conflict occurs between contract documents and applicable laws, codes, ordinances or regulations, the most stringent or legally binding requirement shall govern and be considered a part of this contract to afford the City the maximum benefits.

- L. Negotiated Agreement: The parties acknowledge this is a negotiated agreement, that they have had this Agreement reviewed by their respective legal counsel, and that the terms and conditions of this Agreement are not to be construed against any party on the basis of such party's draftsmanship.
- M. No personal liability: No officer, agent or authorized employee of the City shall be personally responsible for any liability arising under this Agreement, whether expressed or implied, nor for any statement or representation made or in any connection with this Agreement.

IN WITNESS WHEREOF, in consideration of the terms, conditions and covenants contained, or attached and incorporated and made a part, the parties have executed this Agreement by having legally-binding representatives affix their signatures below.

GARTNER, INC.

CITY OF SPOKANE

By _____
Signature Date

By _____
Signature Date

Type or Print Name

Type or Print Name

Title

Title

Attest:

Approved as to form:

City Clerk

Assistant City Attorney

Attachments:

Exhibit A – Certificate Regarding Debarment

Exhibit B – Consultant's Service Agreement

EXHIBIT A

**CERTIFICATION REGARDING DEBARMENT, SUSPENSION,
INELIGIBILITY AND VOLUNTARY EXCLUSION**

1. The undersigned (i.e., signatory for the Subrecipient / Contractor / Consultant) certifies, to the best of its knowledge and belief, that it and its principals:
 - a. Are not presently debarred, suspended, proposed for debarment, declared ineligible, or voluntarily excluded from covered transactions by any federal department or agency;
 - b. Have not within a three-year period preceding this contract been convicted or had a civil judgment rendered against them for commission of fraud or a criminal offense in connection with obtaining, attempting to obtain, or performing a public (federal, state, or local) transaction or contract under a public transaction; violation of federal or state antitrust statutes or commission of embezzlement, theft, forgery, bribery, falsification or destruction of records, making false statements, tax evasion, receiving stolen property, making false claims, or obstruction of justice;
 - c. Are not presently indicted or otherwise criminally or civilly charged by a government entity (federal, state, or local) with commission of any of the offenses enumerated in paragraph (1)(b) of this certification; and,
 - d. Have not within a three-year period preceding this contract had one or more public transactions (federal, state, or local) terminated for cause or default.

2. The undersigned agrees by signing this contract that it shall not knowingly enter into any lower tier covered transaction with a person who is debarred, suspended, declared ineligible, or voluntarily excluded from participation in this covered transaction.

3. The undersigned further agrees by signing this contract that it will include the following clause, without modification, in all lower tier covered transactions and in all solicitations for lower tier covered transactions:

Certification Regarding Debarment, Suspension, Ineligibility and Voluntary Exclusion – Lower Tier Covered Transactions

1. The lower tier contractor certifies, by signing this contract that neither it nor its principals is presently debarred, suspended, proposed for debarment, declared ineligible, or voluntarily excluded from participation in this transaction by any federal department or agency.

 2. Where the lower tier contractor is unable to certify to any of the statements in this contract, such contractor shall attach an explanation to this contract.
4. I understand that a false statement of this certification may be grounds for termination of the contract.

<hr/> Name of Subrecipient / Contractor / Consultant (Type or Print)	<hr/> Program Title (Type or Print)
<hr/> Name of Certifying Official (Type or Print)	<hr/> Signature
<hr/> Title of Certifying Official (Type or Print)	<hr/> Date (Type or Print)

EXHIBIT B

Gartner, Inc. Service Agreement for CITY OF SPOKANE (“Client”)

This Service Agreement (“SA”) is between Gartner, Inc. of 56 Top Gallant Road, Stamford, CT 06902 (“Gartner”) on behalf of itself and all wholly-owned affiliates of Gartner, Inc. and Client of 808 W Spkne Fls Blvd Spokane WA 99201-3333. (“Client”), and includes the Master Client Agreement (08321) between Gartner or Gartner’s parent or affiliate and Client or Client’s parent or affiliate dated OCT-2021 the terms of which are incorporated by reference, and all applicable Service Descriptions. This SA constitutes the complete agreement between Gartner and Client. Client agrees to subscribe to the following Services for the term and fees set forth below.

1. DEFINITIONS AND ORDER SCHEDULE:

Services are the subscription-based research and related services purchased by Client in the Order Schedule below and described in the Service Descriptions. Service Names and Levels of Access are defined in the Service Descriptions. Gartner may periodically update the names and the deliverables for each Service. If Client adds Services or upgrades the level of service or access, an additional Service Agreement will be required.

Service Descriptions describe each Service purchased, specify the deliverables for each Service, and set forth any additional terms unique to a specific Service. Service Descriptions for the Services purchased in this SA may be viewed and downloaded through the hyperlinks listed in Section 2 below or may be attached to this SA in hard copy, and are incorporated by reference into this SA.

<u>Service Name</u>	<u>Level of Access</u>	<u>Quantity</u>	<u>Name of User to be Licensed</u>	<u>Contract Term Start Date</u>	<u>Contract Term End Date</u>	<u>Annual Fee USD</u>	<u>Total Fee USD</u>
Gartner for Chief Financial Officers Team	Leader	1	Matt Boston	01-AUG-2024	30-SEP-2024		\$0.00
Gartner for Chief Financial Officers Team	Advisor Member	1	Jessica Stratton	01-AUG-2024	30-SEP-2024		\$0.00
				Term Total	(Excluding applicable taxes)		\$0.00
Gartner for Chief Financial Officers Team	Leader	1	Matt Boston	01-OCT-2024	30-SEP-2025	\$112,163.00	\$112,163.00
Gartner for Chief Financial Officers Team	Advisor Member	1	Jessica Stratton	01-OCT-2024	30-SEP-2025	\$37,965.00	\$37,965.00
				Term Total	(Excluding applicable taxes)		\$150,128.00
				Total Services:	(Excluding applicable taxes)		\$150,128.00

1-212FEENS 2412 FA000355

The standard configuration for the Chief Financial Officers solution includes three (3) Team Members in addition to the Team Leader. The non-standard configuration provided above is limited to terms of this agreement only.

2. SERVICE DESCRIPTIONS:

<u>Service Name/ Level of Access</u>	<u>Service Description URL</u>
Gartner for Chief Financial Officers Team Leader	http://sd.gartner.com/sd_cfo_team_leader.pdf
Gartner for Chief Financial Officers Team Advisor Member	http://sd.gartner.com/sd_cfo_team_advisor_member.pdf

Offer valid until 30-SEP-2024

3. PAYMENT TERMS

Gartner will invoice Client annually in advance for all Services. Payment is due 30 days from the invoice date. Client shall pay any sales, use, value-added, or other tax or charge imposed or assessed by any governmental entity upon the sale, use or receipt of Services, with the exception of any taxes imposed on the net income of Gartner.

Please attach any required Purchase Order ("**PO**") to this SA and enter the PO number below. If an annual PO is required for multi-year contracts, Client will issue the new PO at least 30 days prior to the beginning of each subsequent contract year. Any pre-printed or additional contract terms included on the PO shall be inapplicable and of no force or effect. All PO's are to be sent to purchaseorders@gartner.com. This SA may be signed in counterparts.

4. CLIENT BILLING INFORMATION

Purchase Order Number

Billing Address

Invoice Recipient Tel. No.

Invoice Recipient Name

Invoice Recipient Email

5. AUTHORIZATION

Client:
CITY OF SPOKANE

Gartner, Inc.

Signature

Signature

Date

Date

Print Name

Print Name

Title

Title

SERVICE DESCRIPTION
Attachment to the Service Agreement
GARTNER FOR CHIEF FINANCIAL OFFICERS TEAM
TEAM LEADER

Gartner for Chief Financial Officers Team: Team Leader (the “Service”) is for CFOs/heads of finance and their leadership teams at the client company (“Client”). The Service provides Client with (i) an ongoing advisory relationship with Gartner, and (ii) access to Gartner Research covering the finance sector and specific finance roles in a team environment. The Service requires the separate purchase of Gartner for Chief Financial Officers Team Member Services.

DELIVERABLES

The Gartner for Chief Financial Officers Team is comprised of two sets of users: (i) the “Team Leader”, and (ii) “Team Members” designated by Client and listed in the Service Agreement. Collectively, the Team Leader and Team Members are “Licensed Users”.

1. The Team Leader is entitled to the following Gartner Deliverables:

- Assigned Service Delivery Team
- Virtual Strategy Meetings
- Peer Experiences
- Peer & Practitioner Research
- Gartner Research for Finance Roles
- Tools and Templates
- Virtual Strategy Meetings
- Functional Diagnostics
- Webinars
- Individual Inquiry
- Team Inquiry
- CFO & Finance Executive Conference Ticket

2. Additional information on the Deliverables listed above include the following:

(a) **Assigned Service Delivery Team:** A Service Partner, who is a member of the Assigned Service Delivery Team (“Delivery Team”), will serve as Licensed User’s primary point of contact for this Service. The Service Partner will work with Licensed User to develop and continuously evolve an advisory plan to: (i) highlight value sought, (ii) identify key issues on which service delivery will focus, and (iii) define how the Service will deliver that value. The Service Partner will, as necessary, select and synthesize research in accordance with the plan. Client interactions with the Service Partner may include Strategy Meetings, research expert dialogues, CFO & Finance Executive Conference attendance, Facilitated Networking interactions or Service Partner teleconferences or meetings. A client success manager, also a member of the Delivery Team, will work in partnership with the Service Partner to facilitate a coordinated service approach.

(b) **Virtual Strategy Meetings:** Service Partner will meet with Team Leader for coaching and advice on strategic planning and execution of (i) review and apply relevant finance research content, (ii) recommend appropriate experts on issues of relevance to Client, and/or (iii) develop, discuss progress of and, where necessary, modify the advisory plan.

(c) **Peer Experiences**

Gartner provides opportunities for peer engagement in a variety of ways. Licensed Users have access to Gartner assets that enable ratings and reviews, connecting with qualified peers, access to community features, and exclusive features specific to client role.

Facilitated Networking: Service Delivery Team will, upon request, arrange meetings with peers around a specific topic to discuss best practices or areas of expertise.

ADDITIONAL USAGE INFORMATION

The Team Leader may forward to others in the client company up to 25 (twenty-five) Gartner Research documents per contract year. This forwarding may not be done in a manner that has the intent or effect of avoiding the purchase of additional User licenses.

Participation in inquiry calls is limited to the Licensed User(s) and Gartner experts only (i.e., non-Users, either inside or outside the client company, may not attend or otherwise participate on an inquiry call). The Team Leader is entitled to two types of inquiry: (i) inquiry sessions with an expert (“Individual Inquiry”) which may be scheduled independent of other Team Members; and (ii) inquiry sessions with an expert and other members of the team (“Team Inquiry”). For Team Inquiry sessions: (i) the Team Leader must schedule and attend the sessions; and (ii) Team Members may lead the discussion or pose questions to the expert on behalf of the team, provided all such questions and discussions advance the Team Leader’s agenda.

The Conference Ticket is a numbered identifier (e.g., 424562) that entitles Licensed User to register for one (1) conference as specified in the Ticket Letter emailed to Client. Tickets are valid for 12 (twelve) months from the date of issue, per the expiration date on the Ticket Letter. Tickets provided as part of a Gartner research offering are valid only for Gartner conferences during the contract term of that service. One (1) Ticket is issued per contract term of 12 (twelve) months – a shorter contract term does not entitle Client to a Ticket. Tickets are transferable within the client company but may not be transferred to another company. A single Ticket may not be used by more than one (1) individual and may not be used for admission to any Gartner conference other than a CFO & Finance Executive Conference.

Client companies around the world trust Gartner to be objective and independent in its research and advice, and Gartner takes that responsibility seriously. To preserve the objectivity of research, Gartner does not promise Clients favorable coverage or leads from its research experts. Gartner does not provide access to confidential client information, offer aid to secure capital funding, or sell any product for use in litigation. There are no exceptions. If you have questions, please email ombuds@gartner.com.

Use of this Service is governed by the [Gartner Usage Policy](#) and the [Gartner Content Compliance Policy](#) which are accessible on the Policies section of gartner.com.

SERVICE DESCRIPTION
Attachment to the Service Agreement
GARTNER FOR CHIEF FINANCIAL OFFICERS TEAM:
ADVISOR TEAM MEMBER

Gartner for Chief Financial Officers Team: Advisor Team Member (the “Service”) is for senior finance leaders and their leadership teams at the client company (“Client”). The Service provides Client with (i) an ongoing advisory relationship with Gartner, and (ii) access to Gartner Research covering the finance sector and specific finance roles in a team environment. This Service requires the separate purchase of a Chief Financial Officers Team Leader Service.

DELIVERABLES

Gartner for Chief Financial Officers is comprised of two sets of users: (i) the “Team Leader”, and (ii) “Team Members” designated by Client and listed in the Service Agreement. Collectively, the Team Leader and Team Members are “Licensed Users”.

1. The Advisor Team Member is entitled to the following Gartner Deliverables:

- Gartner Research for Finance Roles
- Peer Experiences
- Peer & Practitioner Research
- Facilitated Networking
- Tools and Templates
- Functional Diagnostics
- Webinars
- Individual Inquiry
- Team Inquiry
- CFO & Finance Executive Conference Ticket

2. Additional information on the Deliverables listed above include the following:

Licensed Users may deploy Functional Diagnostics to both Licensed and Non-licensed Users in the client company.

ADDITIONAL USAGE INFORMATION

Participation in inquiry calls is limited to Licensed User(s) and Gartner research expert only (i.e., non-Users, either inside or outside of the client company, may not attend or otherwise participate on an inquiry call). Team Members are entitled to two types of inquiry: (i) inquiry sessions with an expert (“Individual Inquiry”) which may be scheduled independent of other Team Members; and (ii) inquiry sessions with an expert and the team (“Team Inquiry”). For Team Inquiry sessions: (i) the Team Leader must schedule and attend the sessions; and (ii) Team Members may lead the discussion or pose questions to the expert on behalf of the team, provided all such questions and discussions advance the Team Leader’s agenda.

The Conference Ticket is a numbered identifier (e.g., 424562) that entitles Licensed User to register for one (1) conference as specified in the Ticket Letter emailed to Client. Tickets are valid for 12 (twelve) months from the date of issue, per the expiration date on the Ticket Letter. Tickets provided as part of a Gartner research offering are valid only for Gartner conferences during the contract term of that service. One (1) Ticket is issued per contract term of 12 (twelve) months – a shorter contract term does not entitle Client to a Ticket. Tickets are transferable within the client company but may not be transferred to another company. A single Ticket may not be used by more than one (1) individual and may not be used for admission to any Gartner conference other than a CFO & Finance Executive Conference.

Client companies around the world trust Gartner to be objective and independent in its research and advice, and Gartner takes that responsibility seriously. To preserve the objectivity of research, Gartner does not

promise Clients favorable coverage or leads from its research experts. Gartner does not provide access to confidential client information, offer aid to secure capital funding, or sell any product for use in litigation. There are no exceptions. If you have questions, please email ombuds@gartner.com.

Use of this Service is governed by the [Gartner Usage Policy](#) and the [Gartner Content Compliance Policy](#) which are accessible on the Policies section of gartner.com.



CERTIFICATE OF LIABILITY INSURANCE

DATE(MM/DD/YYYY)
07/18/2024

THIS CERTIFICATE IS ISSUED AS A MATTER OF INFORMATION ONLY AND CONFERS NO RIGHTS UPON THE CERTIFICATE HOLDER. THIS CERTIFICATE DOES NOT AFFIRMATIVELY OR NEGATIVELY AMEND, EXTEND OR ALTER THE COVERAGE AFFORDED BY THE POLICIES BELOW. THIS CERTIFICATE OF INSURANCE DOES NOT CONSTITUTE A CONTRACT BETWEEN THE ISSUING INSURER(S), AUTHORIZED REPRESENTATIVE OR PRODUCER, AND THE CERTIFICATE HOLDER.

IMPORTANT: If the certificate holder is an ADDITIONAL INSURED, the policy(ies) must have ADDITIONAL INSURED provisions or be endorsed. If SUBROGATION IS WAIVED, subject to the terms and conditions of the policy, certain policies may require an endorsement. A statement on this certificate does not confer rights to the certificate holder in lieu of such endorsement(s).

PRODUCER Aon Risk Services Northeast, Inc. Connecticut Office 800 Connecticut Ave Norwalk CT 06854 USA	CONTACT NAME: PHONE (A/C. No. Ext): 8662837122 FAX (A/C. No.): (800) 363-0105		
	E-MAIL ADDRESS:		
INSURER(S) AFFORDING COVERAGE		NAIC #	
INSURED Garther, Inc. 56 Top Gallant Road PO Box 10212 Stamford CT 06904-2212 USA	INSURER A: The Continental Insurance Company		35289
	INSURER B: American Casualty Co. of Reading PA		20427
	INSURER C: Valley Forge Insurance Co		20508
	INSURER D: National Fire Ins. Co. of Hartford		20478
	INSURER E: AIG Specialty Insurance Company		26883
	INSURER F: National Fire & Marine Ins Co		20079

COVERAGES	CERTIFICATE NUMBER: 570107284462	REVISION NUMBER:
------------------	---	-------------------------

THIS IS TO CERTIFY THAT THE POLICIES OF INSURANCE LISTED BELOW HAVE BEEN ISSUED TO THE INSURED NAMED ABOVE FOR THE POLICY PERIOD INDICATED. NOTWITHSTANDING ANY REQUIREMENT, TERM OR CONDITION OF ANY CONTRACT OR OTHER DOCUMENT WITH RESPECT TO WHICH THIS CERTIFICATE MAY BE ISSUED OR MAY PERTAIN, THE INSURANCE AFFORDED BY THE POLICIES DESCRIBED HEREIN IS SUBJECT TO ALL THE TERMS, EXCLUSIONS AND CONDITIONS OF SUCH POLICIES. LIMITS SHOWN MAY HAVE BEEN REDUCED BY PAID CLAIMS. **Limits shown are as requested**

INSR LTR	TYPE OF INSURANCE	ADDITIONAL INSURED	SUBROGATION WAIVED	POLICY NUMBER	POLICY EFF (MM/DD/YYYY)	POLICY EXP (MM/DD/YYYY)	LIMITS	
D	<input checked="" type="checkbox"/> COMMERCIAL GENERAL LIABILITY <input type="checkbox"/> CLAIMS-MADE <input checked="" type="checkbox"/> OCCUR GEN'L AGGREGATE LIMIT APPLIES PER: <input type="checkbox"/> POLICY <input type="checkbox"/> PROJECT <input checked="" type="checkbox"/> LOC OTHER:			6081135048	06/30/2024	06/30/2025	EACH OCCURRENCE	\$1,000,000
							DAMAGE TO RENTED PREMISES (Ea occurrence)	\$1,000,000
							MED EXP (Any one person)	\$15,000
							PERSONAL & ADV INJURY	\$1,000,000
							GENERAL AGGREGATE	\$2,000,000
							PRODUCTS - COMP/OP AGG	\$2,000,000
A	<input checked="" type="checkbox"/> AUTOMOBILE LIABILITY <input checked="" type="checkbox"/> ANY AUTO <input type="checkbox"/> OWNED AUTOS ONLY <input type="checkbox"/> SCHEDULED AUTOS <input type="checkbox"/> HIRED AUTOS ONLY <input type="checkbox"/> NON-OWNED AUTOS ONLY			6081318420	06/30/2024	06/30/2025	COMBINED SINGLE LIMIT (Ea accident)	\$1,000,000
							BODILY INJURY (Per person)	
							BODILY INJURY (Per accident)	
							PROPERTY DAMAGE (Per accident)	
A	<input checked="" type="checkbox"/> UMBRELLA LIAB <input checked="" type="checkbox"/> OCCUR <input type="checkbox"/> EXCESS LIAB <input type="checkbox"/> CLAIMS-MADE DED <input checked="" type="checkbox"/> RETENTION \$10,000			6011488543	06/30/2024	06/30/2025	EACH OCCURRENCE	\$10,000,000
							AGGREGATE	\$10,000,000
B	<input checked="" type="checkbox"/> WORKERS COMPENSATION AND EMPLOYERS' LIABILITY ANY PROPRIETOR / PARTNER / EXECUTIVE OFFICER/MEMBER EXCLUDED? (Mandatory in NH) If yes, describe under DESCRIPTION OF OPERATIONS below			585006231	06/30/2024	06/30/2025	<input checked="" type="checkbox"/> PER STATUTE <input type="checkbox"/> OTHER	
B				AOS	06/30/2024	06/30/2025	E.L. EACH ACCIDENT	\$1,000,000
				585006276			E.L. DISEASE-EA EMPLOYEE	\$1,000,000
				CA			E.L. DISEASE-POLICY LIMIT	\$1,000,000
E	<input checked="" type="checkbox"/> E&O - Miscellaneous <input checked="" type="checkbox"/> Professional-Primary			013572106	06/30/2024	06/30/2025	Professional Liab.	\$10,000,000
				Cyber/Privacy/Claims			Cyber	\$10,000,000
				SIR applies per policy terms & conditions			Prof\$5MSIR/CyberSIR	\$2,500,000

DESCRIPTION OF OPERATIONS / LOCATIONS / VEHICLES (ACORD 101, Additional Remarks Schedule, may be attached if more space is required)
The City of Spokane its officers and employees are included as Additional Insured as required by written contract but limited to the operations of the Insured under said contract, per the applicable endorsement with respects to the General Liability, Umbrella Liability and Professional Liability policies. In addition, a waiver of subrogation can be granted in favor of a third party as required by written contract but limit to the operations of the Insured under said contract, with respect to the General Liability, Automobile Liability, Umbrella Liability, Professional Liability and workers Compensation/Employer's Liability policies. The General Liability, Umbrella Liability and Professional Liability policies evidenced herein is Primary to other insurance available to the certificate holder, but only to the extent required by written contract with the Insured.

CERTIFICATE HOLDER	CANCELLATION
City of Spokane 808 West Spokane Falls Blvd. Spokane WA 99201 USA	SHOULD ANY OF THE ABOVE DESCRIBED POLICIES BE CANCELLED BEFORE THE EXPIRATION DATE THEREOF, NOTICE WILL BE DELIVERED IN ACCORDANCE WITH THE POLICY PROVISIONS. AUTHORIZED REPRESENTATIVE

Holder Identifier :

Certificate No : 570107284462





ADDITIONAL REMARKS SCHEDULE

AGENCY Aon Risk Services Northeast, Inc.		NAMED INSURED Gartner, Inc.	
POLICY NUMBER See Certificate Number: 570107284462			
CARRIER See Certificate Number: 570107284462	NAIC CODE	EFFECTIVE DATE:	

ADDITIONAL REMARKS

**THIS ADDITIONAL REMARKS FORM IS A SCHEDULE TO ACORD FORM,
FORM NUMBER: ACORD 25 FORM TITLE: Certificate of Liability Insurance**

INSURER(S) AFFORDING COVERAGE	NAIC #
INSURER	
INSURER	
INSURER	
INSURER	

ADDITIONAL POLICIES If a policy below does not include limit information, refer to the corresponding policy on the ACORD certificate form for policy limits.

INSR LTR	TYPE OF INSURANCE	ADDL INSD	SUBR WVD	POLICY NUMBER	POLICY EFFECTIVE DATE (MM/DD/YYYY)	POLICY EXPIRATION DATE (MM/DD/YYYY)	LIMITS	
	WORKERS COMPENSATION							
C		N/A		585006326 Retro - AZ OR WI MA	06/30/2024	06/30/2025		



ADDITIONAL REMARKS SCHEDULE

AGENCY Aon Risk Services Northeast, Inc.		NAMED INSURED Gartner, Inc.	
POLICY NUMBER See Certificate Number: 570107284462			
CARRIER See Certificate Number: 570107284462	NAIC CODE	EFFECTIVE DATE:	

ADDITIONAL REMARKS

THIS ADDITIONAL REMARKS FORM IS A SCHEDULE TO ACORD FORM,

FORM NUMBER: ACORD 25 **FORM TITLE:** Certificate of Liability Insurance

Additional Description of Operations / Locations / Vehicles:

The General Liability, Umbrella Liability and Professional Liability policies evidenced herein is Non-Contributory to other insurance available to the Certificate Holder, but only to the extent required by written contract with the Insured. Umbrella Liability follows form of underlying coverage: General Liability, Automobile Liability and Employer's Liability.



< Business Lookup

License Information:

[New search](#) [Back to results](#)

Entity name: GARTNER, INC.

Business name: GARTNER

Entity type: Profit Corporation

UBI #: 601-422-801

Business ID: 001

Location ID: 0001

Location: Active

Location address: 56 TOP GALLANT PO
STAMFORD CT 06904

Mailing address: 13200 PAUL J DOHERTY PKWY
FORT MYERS FL 33913-9380

Excise tax and reseller permit status: [Click here](#)

Secretary of State status: [Click here](#)

Endorsements

Endorsements held at this loca	License #	Count	Details	Status	Expiration date	First issuance c
Redmond General Business - Non-Resident	RED99-000062			Active	Mar-31-2025	Jun-29-1999
Spokane General Business - Non-Resident				Active	Mar-31-2025	Feb-22-2022

Governing People May include governing people not registered with Secretary of State

Governing people	Title
BISSON, PETER	
BRESSLER, RICHARD J.	
CESAN, RAUL	

Governing people**Title**

COHEN, SETH

DYKSTRA, KAREN E.

FERGUSON, DIANA S.

FUCHS, ANNE SUTHERLAND

GRABE, WILLIAM O.

GUTIERREZ, JOSE M.

HALL, EUGENE A.

KIM, THOMAS S.

PAGLIUCA, STEPHEN

SAFIAN, CRAIG

SERRA, EILEEN M

SMITH, JAMES C.

Registered Trade Names

Registered trade names	Status	First issued
GARTNER INC	Active	Mar-21-2019

The Business Lookup information is updated nightly. Search date and time: 7/10/2024 11:35:38 AM

Contact us

How are we doing?

Take our survey!

Don't see what you expected?

Check if your browser is supported



Agenda Sheet for City Council:

Committee: Finance & Administration **Date:** 07/22/2024

Committee Agenda type: Consent

Date Rec'd

7/24/2024

Clerk's File #

OPR 2024-0611

Cross Ref #

Project #

Council Meeting Date: 08/12/2024

Submitting Dept

INFORMATION TECHNOLOGY

Bid #

Contact Name/Phone

MICHAEL 625-6468

Requisition #

CR 26474

Contact E-Mail

MSLOON@SPOKANECITY.ORG

Agenda Item Type

Contract Item

Council Sponsor(s)

MCATHCART BWILKERSON ZZAPPONE

Agenda Item Name

5300 5-YEAR LEASE OF RISO COMCOLOR 9730 PRINTER FOR THE MAIL CENTER

Agenda Wording

Canon Solutions America, Inc. (Melville, NY) was selected for lease of a RISO Comcolor 9730 Printer for the Mail Center. This lease is for five (5) years. Total lease term is September 24, 2024, through September 23, 2029.

Summary (Background)

This printer is primarily used to print revenue-generating utility bills for the city. It is also used for printing notice letters for the Development Services Center and Water department, which keep customers up to date on permits, maintenance, and any associated fees. The Accounts Receivable invoices are printed to this printer, which are then mailed out to collect payment, and we print the payroll reports utilizing this printer.

Lease? YES

Grant related? NO

Public Works? NO

Fiscal Impact

Approved in Current Year Budget? YES

Total Cost \$ 147,720.00 plus appl tax

Current Year Cost \$ 10,734.32

Subsequent Year(s) Cost \$ \$150,280.48

Narrative

The existing printer lease for the Mail Center is expiring. This new lease with Canon Solutions America, Inc. replaces that expiring lease.

Amount

Budget Account

Expense \$ 10,734.32 # 5300-73700-18880-54501 2024 budget

Expense \$ 32,202.96 # 5300-73700-18880-54501 2025 budget

Expense \$ 32,202.96 # 5300-73700-18880-54501 2026 budget

Expense \$ 32,202.96 # 5300-73700-18880-54501 2027 budget

Expense \$ 32,202.96 # 5300-73700-18880-54501 2028 budget

Expense \$ 21,468.64 # 5300-73700-18880-54501 2029 budget



Continuation of Wording, Summary, Approvals, and Distribution

Agenda Wording

The total lease amount for five (5) years will be \$147,720.00 plus applicable tax. The City is utilizing the OMNIA Partners, Public Sector Cooperative Purchasing Program ("OMNIA Partners Program") contract No. 2020002755 with Canon Solutions America, Inc. ("Supplier") to obtain the best pricing.

Summary (Background)

Approvals

<u>Dept Head</u>	MARTINEZ, LAZ
<u>Division Director</u>	SLOON, MICHAEL
<u>Accounting Manager</u>	BUSTOS, KIM
<u>Legal</u>	SCHOEDEL, ELIZABETH
<u>For the Mayor</u>	PICCOLO, MIKE

Additional Approvals

<u>PURCHASING</u>	NECHANICKY, JASON
<u>ACCOUNTING -</u>	BAIRD, CHRISTI

Distribution List

Danny Mitchell CSA_DocReview@csa.canon.com	Accounting - ywang@spokanecity.org
Contract Accounting - ddaniels@spokanecity.org	Legal - mharrington@spokanecity.org
Purchasing - cwahl@spokanecity.org	IT - itadmin@spokanecity.org
Tax & Licenses	

Committee Agenda Sheet

Finance & Administration Committee

Committee Date	July 22, 2024
Submitting Department	IT
Contact Name	Mike Sloon
Contact Email & Phone	msloon@spokanecity.org , 509-625-6468
Council Sponsor(s)	<u>CM Cathcart, CP Wilkerson, CM Zappone</u>
Select Agenda Item Type	<input checked="" type="checkbox"/> Consent <input type="checkbox"/> Discussion Time Requested:
Agenda Item Name	5300 – 5-year Lease of RISO Comcolor 9730 Printer for the Mail Center
Proposed Council Action	<input checked="" type="checkbox"/> Approval to proceed to Legislative Agenda <input type="checkbox"/> Information Only
Summary (Background) *use the Fiscal Impact box below for relevant financial information	<p>Canon Solutions America, Inc. (Melville, NY) was selected for lease of a RISO Comcolor 9730 Printer for the Mail Center.</p> <p>This printer is primarily used to print revenue-generating utility bills for the city. It is also used for printing notice letters for the Development Services Center and Water department, which keep customers up to date on permits, maintenance, and any associated fees. The Accounts Receivable invoices are printed to this printer, which are then mailed out to collect payment, and we print the payroll reports utilizing this printer.</p> <p>This lease is for five (5) years. Lease and Service Pricing are fixed for five (5) years and includes parts and labor. Total lease term is September 24, 2024, through September 23, 2029.</p> <p>The first-year lease amount is \$29,544.00 plus tax and will be billed quarterly.</p> <p>5300-73700-18880-54501 = \$20,664.00 plus tax = \$22,523.76 5300-73700-18850-54804 = \$ 8,880.00 plus tax = \$ 9,679.20 \$29,544.00 plus tax = \$32,202.96</p> <p>Current expiring lease yearly amount is \$32,178.77.</p> <p>The total lease amount for five (5) years will be \$147,720.00 plus applicable tax.</p>
Fiscal Impact	
Approved in current year budget? <input checked="" type="checkbox"/> Yes <input type="checkbox"/> No <input type="checkbox"/> N/A Total Cost: \$147,720.00 for five years plus applicable tax. Current year cost: \$32,202.96 including tax Subsequent year(s) cost:	
Narrative: The existing printer lease for the Mail Center is expiring. This new lease with Canon Solutions America, Inc. replaces that expiring lease. The City is utilizing the OMNIA Partners, Public Sector Cooperative Purchasing Program (“OMNIA Partners Program”) contract No. 2020002755 with Canon Solutions America, Inc. (“Supplier”) to obtain the best pricing.	
Funding Source <input type="checkbox"/> One-time <input checked="" type="checkbox"/> Recurring <input type="checkbox"/> N/A Specify funding source: Select Funding Source* Is this funding source sustainable for future years, months, etc? Click or tap here to enter text.	

Expense Occurrence One-time Recurring N/A

Other budget impacts: (revenue generating, match requirements, etc.)

Operations Impacts (If N/A, please give a brief description as to why)

What impacts would the proposal have on historically excluded communities?

Not applicable

How will data be collected, analyzed, and reported concerning the effect of the program/policy by racial, ethnic, gender identity, national origin, income level, disability, sexual orientation, or other existing disparities?

Not applicable

How will data be collected regarding the effectiveness of this program, policy or product to ensure it is the right solution?

Not applicable

Describe how this proposal aligns with current City Policies, including the Comprehensive Plan, Sustainability Action Plan, Capital Improvement Program, Neighborhood Master Plans, Council Resolutions, and others?

This service aligns with the Sustainable Resources strategic initiative based on sound financial objectives, and quality customer service by providing a stable and current mailing center infrastructure.



City of Spokane
CONTRACT
LEASE OF RISO
COMCOLOR PRINTER 9730

THIS CONTRACT is between the **CITY OF SPOKANE** as ("City"), a Washington municipal corporation, and **CANON SOLUTIONS AMERICA, INC.**, whose address is One Canon Park, Melville, NY 11747, payment address is Canon Financial Services, Inc., 14904 Collections Center Drive, Chicago, IL 60693, as ("Company"), individually hereafter referenced as a "party", and together as the "parties".

The parties agree as follows:

1. **PERFORMANCE.** The Company will Lease a Riso Comcolor 9730 Printer and provide Service, Parts and Labor and pick up of the equipment at the end of the lease, in accordance with the OMNIA Partners, Public Sector Cooperative Purchasing Program Contract No. 2020002755 as the Overriding Contract under the Master Sales and Service Agreement #54231, attached as Exhibit B. In the event of a discrepancy between the documents this City Contract controls.
2. **CONTRACT TERMS.** The Contract shall begin September 24, 2024, and run through September 23, 2029, unless amended by written agreement or terminated earlier under the provisions.
3. **COMPENSATION.** Total compensation under this Contract shall not exceed **ONE HUNDRED FORTY-SEVEN THOUSAND SEVEN HUNDRED TWENTY AND NO 100 DOLLARS (\$147,720.00)**, plus applicable sales tax; billed quarterly, for everything furnished and done under this Contract. This is the maximum amount to be paid under this Contract for the work described in Section 1 above, and shall not be exceeded without the prior written authorization of the City in the form of an executed amendment to this Contract. Notwithstanding the foregoing, Company will invoice City and City agrees to pay all maintenance charges in excess of the total compensation mentioned herein.
4. **PAYMENT.** The Company shall send its application for payment to Information Technology, Administration Office, Seventh Floor, City Hall, 808 West Spokane Falls Boulevard, Spokane, Washington 99201. **Payment will be made via direct deposit/ACH** within thirty (30) days after receipt of the Company's application except as provided by state law.
5. **COMPLIANCE WITH LAWS.** Each party shall comply with all applicable federal, state, and local laws and regulations.
6. **ASSIGNMENTS.** This Contract is binding on the parties and their heirs, successors, and assigns. Neither party may assign, transfer or subcontract its interest, in whole or in part, without the other party's prior written consent, which shall not be unreasonably withheld, delayed, or

conditioned; provided, that the Company may assign any of its rights or obligations hereunder to any company which is a wholly-owned subsidiary of the Company's ultimate parent company.

7. AMENDMENTS. This Contract may be amended at any time by mutual written agreement.

8. ANTI-KICKBACK. No officer or employee of the City of Spokane, having the power or duty to perform an official act or action related to this Contract shall have or acquire any interest in the Contract, or have solicited, accepted or granted a present or future gift, favor, service or other thing of value from or to any person involved in this Contract.

9. TERMINATION. The City may terminate this Contract by thirty (30) days' written notice to the Company due to non-appropriation of fiscal funding, provided that the City (i) provide proof that funding was requested and (ii) provide proof that funding was denied. Additionally, either party may terminate this Contract for cause by thirty (30) days' written notice to the other party. In the event of such termination, the City shall pay the Company for all work previously authorized and performed prior to the termination date.

10. INSURANCE. During the term of the Agreement, the Company shall maintain in force at its own expense, the following insurance coverages:

- A. Worker's Compensation Insurance in compliance with RCW 51.12.020, which requires subject employers to provide workers' compensation coverage for all their subject workers; and
- B. General Liability Insurance on an occurrence basis, with a limit of not less than \$1,000,000 each occurrence for bodily injury and property damage. It shall include contractual liability coverage. It shall provide that the City, its officers and employees are included as additional insureds, but only with respect to the Company's services to be provided under this contract (such requirement may be met with production of a blanket endorsement);
 - i. Acceptable supplementary Umbrella insurance coverage, combined with the Company's General Liability insurance policy must be a *minimum* of \$1,000,000, in order to meet the insurance coverages required under this Contract;
- C. Automobile Liability Insurance with a combined single limit, or the equivalent of not less than \$1,000,000 each accident for bodily injury and property damage, including coverage for owned, hired and non-owned vehicles.

There shall be no cancellation, material change, or reduction of limits change in that Company is unable to meet the required coverages specified within, or intent not to renew the insurance coverage(s) without written notice from the Company or its insurer(s) to the City. As evidence of the insurance coverage(s) required by this Agreement, the Company shall furnish Certificates of Insurance (COI) to the City at the time it returns this signed Agreement. **The certificate shall specify the City of Spokane as "Additional Insured"** specifically for Company's services under this Agreement, as well as all of the parties who are additional insureds, and include applicable blanket policy Additional Insured endorsements. The Company shall be financially responsible for all pertinent deductibles, self-insured retentions, and/or self-insurance.

11. INDEMNIFICATION. The Company shall defend, indemnify, and hold the City and its officers and employees harmless from all claims, demands, or suits at law or equity asserted by third parties for bodily injury (including death) and/or property damage which arise from the

Company's negligence or willful misconduct under this Agreement, including reasonable attorneys' fees and litigation costs; provided that nothing herein shall require a Company to indemnify the City against and hold harmless the City from claims, demands or suits based solely upon the negligence of the City, its agents, officers, and employees. If a claim or suit is caused by or results from the concurrent negligence of the Company's agents or employees and the City, its agents, officers and employees, this indemnity provision shall be valid and enforceable to the extent of the negligence of the Company, its agents or employees. The Company specifically assumes liability and agrees to defend, indemnify, and hold the City harmless for actions brought by the Company's own employees against the City, to the extent such action does not result from the negligence of the City. The indemnity and agreement to defend and hold the City harmless provided for in this section shall survive any termination or expiration of this agreement.

12. DEBARMENT AND SUSPENSION. The Company has provided its certification that it is in compliance with and shall not contract with individuals or organizations which are debarred, suspended, or otherwise excluded from or ineligible from participation in Federal Assistance Programs under Executive Order 12549 and "Debarment and Suspension", codified at 29 CFR part 98.

13. SEVERABILITY. In the event any provision of this Contract should become invalid, the rest of the Contract shall remain in full force and effect.

14. STANDARD OF PERFORMANCE. The silence or omission in the Contract regarding any detail required for the proper performance of the work, means that the Company shall perform in accordance with generally accepted industry standards and practice.

15. NONDISCRIMINATION. No individual shall be excluded from participation in, denied the benefit of, subjected to discrimination under, or denied employment in the administration of or in connection with this Contract because of age, sex, race, color, religion, creed, marital status, familial status, sexual orientation including gender expression or gender identity, national origin, honorably discharged veteran or military status, the presence of any sensory, mental or physical disability, or use of a service animal by a person with disabilities. The Company agrees to comply with, and to require that all subcontractors comply with, Section 504 of the Rehabilitation Act of 1973 and the Americans with Disabilities Act, as applicable to the Company.

16. BUSINESS REGISTRATION REQUIREMENT. Section 8.01.070 of the Spokane Municipal Code states that no person may engage in business with the City without first having obtained a valid annual business registration. The Company shall be responsible for contacting the State of Washington Business License Services at www.dor.wa.gov or 360-705-6741 to obtain a business registration. If the Company does not believe it is required to obtain a business registration, it may contact the City's Taxes and Licenses Division at (509) 625-6070 to request an exemption status determination.

17. AUDIT / RECORDS. To the extent required by applicable law, the Company and its subcontractors shall maintain for a minimum of three (3) years following final payment all records related to fees charged, or invoices issued, under the Contract. The Company and its subcontractors shall provide access to authorized City representatives, at reasonable times and in a reasonable manner to inspect and copy any such record, provided no more than once per year or otherwise required under applicable law. In the event of conflict between this provision and related auditing provisions required under federal law applicable to the Contract, the federal law shall prevail.

18. CONFIDENTIALITY/PUBLIC RECORDS. Notwithstanding anything to the contrary, City will maintain the confidentiality of Company's materials and information only to the extent that is legally allowed in the State of Washington. City is bound by the State Public Records Act, RCW Ch. 42.56. That law presumptively makes all records in the possession of the City public records which are freely available upon request by anyone. In the event that City gets a valid public records request for Company's materials or information and the City determines there are exemptions only the Company can assert, City will endeavor to give Company notice. Company, at its own expense, will be required to go to Court to get an injunction preventing the release of the requested records. In the event that Company does not get a timely injunction preventing the release of the records, the City will comply with the Public Records Act and release the records.

19. DISPUTES. This Contract shall be performed under the laws of the State of Washington. Any litigation to enforce this Contract or any of its provisions shall be brought in Spokane County, Washington.

CANON SOLUTIONS AMERICA, INC.

CITY OF SPOKANE

By _____
Signature Date

By _____
Signature Date

Type or Print Name

Type or Print Name

Title

Title

Attest:

Approved as to form:

City Clerk

Assistant City Attorney

Attachments that are part of this Agreement:
Exhibit A – Certificate Regarding Debarment
Exhibit B – Company's Master Sales and Service Agreement

24-111

**EXHIBIT A
CERTIFICATION REGARDING DEBARMENT, SUSPENSION,
INELIGIBILITY AND VOLUNTARY EXCLUSION**

1. The undersigned (i.e., signatory for the Subrecipient / Contractor / Consultant) certifies, to the best of its knowledge and belief, that it and its principals:
 - a. Are not presently debarred, suspended, proposed for debarment, declared ineligible, or voluntarily excluded from covered transactions by any federal department or agency;
 - b. Have not within a three-year period preceding this contract been convicted or had a civil judgment rendered against them for commission of fraud or a criminal offense in connection with obtaining, attempting to obtain, or performing a public (federal, state, or local) transaction or contract under a public transaction; violation of federal or state antitrust statutes or commission of embezzlement, theft, forgery, bribery, falsification or destruction of records, making false statements, tax evasion, receiving stolen property, making false claims, or obstruction of justice;
 - c. Are not presently indicted or otherwise criminally or civilly charged by a government entity (federal, state, or local) with commission of any of the offenses enumerated in paragraph (1)(b) of this certification; and,
 - d. Have not within a three-year period preceding this contract had one or more public transactions (federal, state, or local) terminated for cause or default.

2. The undersigned agrees by signing this contract that it shall not knowingly enter into any lower tier covered transaction with a person who is debarred, suspended, declared ineligible, or voluntarily excluded from participation in this covered transaction.

3. The undersigned further agrees by signing this contract that it will include the following clause, without modification, in all lower tier covered transactions and in all solicitations for lower tier covered transactions:

Certification Regarding Debarment, Suspension, Ineligibility and Voluntary Exclusion – Lower Tier Covered Transactions

1. The lower tier contractor certified, by signing this contract that neither it nor its principals is presently debarred, suspended, proposed for debarment, declared ineligible, or voluntarily excluded from participation in this transaction by any federal department or agency.

 2. Where the lower tier contractor is unable to certify to any of the statements in this contract, such contractor shall attach an explanation to this contract.
4. I understand that a false statement of this certification may be grounds for termination of the contract.

<hr style="border: none; border-top: 1px solid black; margin-bottom: 5px;"/> Name of Subrecipient / Contractor / Consultant (Type or Print)	<hr style="border: none; border-top: 1px solid black; margin-bottom: 5px;"/> Program Title (Type or Print)
<hr style="border: none; border-top: 1px solid black; margin-bottom: 5px;"/> Name of Certifying Official (Type or Print)	<hr style="border: none; border-top: 1px solid black; margin-bottom: 5px;"/> Signature
<hr style="border: none; border-top: 1px solid black; margin-bottom: 5px;"/> Title of Certifying Official (Type or Print)	<hr style="border: none; border-top: 1px solid black; margin-bottom: 5px;"/> Date (Type or Print)

EXHIBIT B



Canon Solutions America, Inc. ("CSA")
One Canon Park, Melville, NY 11747
(800) 613-2228

MA54231

Salesperson: Sierra Love-Ensminger Order Date: 5/21/2024

Customer ("you"):

Company: SPOKANE CITY OF		
DBA:		
Address: 808 W SPOKANE FALLS BLVD PURCHASING		
City: SPOKANE		County: SPOKANE
State: WA	Zip: 99201-3333	Phone #: 509-625-6460
Contact: TC Brenden		
Email: tbrenden@spokanecity.org		

Applicable Terms and Conditions	Customer Organizational Information
<p>TERMS AND CONDITIONS ARE AVAILABLE AT: ESS.CSA.CANON.COM/CUSTOMERDOCUMENTS</p> <p>The CSA customer terms and conditions located at the above website ("Terms") form part of this Agreement. The Terms include general terms, and terms for product and service purchase, maintenance, support and leasing (pursuant to the terms of Rider G); managed print services; and quotes. The Terms applicable to each of your transactions will be referenced in the Order Schedule.</p> <p>By your initials herein and signature below, you understand and acknowledge such Terms and agree to comply with those applicable to each Order Schedule.</p> <p>_____</p> <p>Customer Initials</p>	<p>Federal Tax ID Number: _____</p> <p>Organization type:</p> <p>Address for Notices: Attn: TC Brenden Address: 808 W SPOKANE FALLS BLVD PURCHASING Address 2: City: SPOKANE State: WA Zip: 99201-3333 Email: tbrenden@spokanecity.org</p>

BY YOUR SIGNATURE BELOW, YOU AGREE TO LEASE, PURSUANT TO THE TERMS OF RIDER G, OR PURCHASE, AS SPECIFIED IN THIS AGREEMENT, THE ITEMS LISTED IN ANY SCHEDULE, RIDER OR ADDENDA (AS APPROVED BY CSA) TO THIS AGREEMENT. YOU ACKNOWLEDGE RECEIPT OF A COPY OF THIS AGREEMENT, AND AGREE TO ABIDE BY ALL OF THE TERMS AND CONDITIONS OF THIS FACE PAGE, APPLICABLE SCHEDULE(S), RIDER(S) AND SUCH ADDENDA, THE QUOTE, AND THE APPLICABLE TERMS AND CONDITIONS IDENTIFIED ABOVE, ALL OF WHICH IS INCORPORATED HEREIN AND MADE PART OF THIS AGREEMENT.

Customer's Authorized Signature _____

Printed Name _____ Title _____ Date _____



Lease Schedule ("Schedule") - Blended (SER-800)

Canon Solutions America, Inc. ("CSA")
One Canon Park, Melville, NY 11747
(800)-613-2228

Customer: SPOKANE CITY OF
Agreement #: MA54231

CFS App #: 2003199
Transaction #: S21091353

Salesperson: Sierra Love-Ensminger
Order Date: 05/21/24

Table with columns: Billing Information, Payment Information, Equipment Maintenance Information, Other Transaction Details, Excess Per Image Charge(s). Includes details like Customer Account: 1843809, Lease Term: 60 Months, # of Lease Payments: 20, Total: \$7,386.00.

Table with columns: Item Code, Listed Items Description, Qty, Ship To & Maintenance Billing Information. Lists items like RISO COMCOLOR GL 9730 MAIN UNIT-S-8440W, RISO POWER CORD FOR HIGH CAPACITY STACKER, etc.

Additional Requirements: Consumables: Service Only, Meter Method: Remote Reporting Agent, For CSA USE ONLY: Config: A | 57214403

OC: UNIVERSITY OF CALIFORNIA PURCHASING AGREEMENT #2020002755
THIS SCHEDULE IS ENTERED INTO PURSUANT TO, AND INCORPORATES THE TERMS OF, THE MASTER SALES AND SERVICES AGREEMENT REFERENCED AS THE AGREEMENT # ABOVE ("AGREEMENT"), INCLUDING THE MASTER LEASE TERMS SET FORTH AS RIDER G THERETO WHICH SHALL CONTROL (THE "LEASE TERMS"). TO THE EXTENT THE TERMS OF AN EXISTING CFS MASTER AGREEMENT ARE REFERENCED ON THIS SCHEDULE (THE "EXISTING MASTER CFS LEASE") AND ARE APPLICABLE TO THIS SCHEDULE, THEY SHALL CONTROL OVER THE MASTER LEASE TERMS SET FORTH AS RIDER G TO THE AGREEMENT FOR SO LONG AS THE EXISTING MASTER CFS LEASE REMAINS IN EFFECT. STANDARD TERMS AND CONDITIONS AND APPLICABLE RIDERS INCORPORATED HEREIN ARE AVAILABLE AT ESS.CSA.CANON.COM/CUSTOMERDOCUMENTS, AND SHALL APPLY TO THE EXTENT NOT MODIFIED BY THE AGREEMENT. THIS SCHEDULE CONSTITUTES A LEASE OF THE LISTED ITEMS, AND IS BINDING ON CUSTOMER UPON SIGNING BY CUSTOMER, AND IS BINDING ON CSA AND LESSOR AS PROVIDED IN THE LEASE TERMS. THIS SCHEDULE IS NON-CANCELABLE BY CUSTOMER. CUSTOMER REPRESENTS THAT EXECUTION OF THIS SCHEDULE HAS BEEN DULY AUTHORIZED. BY YOUR SIGNATURE, CUSTOMER AGREES TO LEASE THE LISTED ITEMS AND, IF SELECTED, TO PURCHASE THE MAINTENANCE SERVICES DESCRIBED HEREIN. YOU ACKNOWLEDGE RECEIPT OF A COPY OF THIS SCHEDULE.

Customer Authorized Signature: Printed Name: Title: Date:

ACCEPTANCE CERTIFICATE

To: CSA and Lessor: Customer certifies that (a) the Listed Items referred to in the above Schedule have been received, (b) installation has been completed, (c) the Listed Items have been examined by Customer and are in good operating order and condition and are, in all respects, satisfactory to the Customer, and (d) the Listed Items are irrevocably accepted by the Customer for all purposes under the Agreement. Accordingly, Customer hereby authorizes billing under this Schedule.

Authorized Signature: Printed Name: Title: Date:

For Internal Purposes Only:

CFS Authorized Signature: Printed Name: Title: Date:

Riso Comcolor 9730



CANON SOLUTIONS AMERICA

Configuration Details and Pricing

RISO COMCOLOR GL 9730 MAIN UNIT-S-8440W

RISO POWER CORD FOR HIGH-CAPACITY STACKER - 488-00050-009

RISO FACE DOWN TRAY-S-7347

RISO HIGH-CAPACITY FEEDER-S-7343G

RISO PAPER EJECTION ATTACHMENT G10-S-7356

RISO HIGH-CAPACITY STACKER-S-7349G

RISO POWER CORD FOR FACE DOWN FINISHER -488-00050-009

RISO CORD-488-00050-009

RISO COMCOLOR EXPRESS FS2100C - S-8471

RISO CONTROL CARD KIT GL9730-S-8410

HIGH PRODUCTION COLOR RISO INKJET IMPLEMENTATION AND OPERATOR TRAINING BY PRODUCTION SERVICES RESOURCE

RISO GL SERIES INSTALL PAK

Pricing

60 Month FMV lease

Billed **Quarterly** at: **\$7,386**

Includes **600,000** Quarterly images

Overage Rate reconciled quarterly: **\$.0037**

Service Agreement

Lease and Service Pricing fixed for 5 years - includes **parts and labor**.

Omnia Language: Notwithstanding any provision of this purchase order to the contrary, the use of this purchase order shall be for the consumers (or buyer's) administrative convenience only, and any terms conditions on this purchase which conflict with or vary from the terms contained in agreement 2020002755 between Canon Solutions America, inc. and the University of California, shall be deemed null and void.

Vendor: Canon Solutions America, Inc

One Canon Park Melville, NY 11747

Remittance Details: Canon Financial Services, Inc
14904 Collections Center Drive Chicago IL 60693

Quote Valid until 6/30/24



CERTIFICATE OF LIABILITY INSURANCE

DATE (MM/DD/YYYY)
05/09/2024

THIS CERTIFICATE IS ISSUED AS A MATTER OF INFORMATION ONLY AND CONFERS NO RIGHTS UPON THE CERTIFICATE HOLDER. THIS CERTIFICATE DOES NOT AFFIRMATIVELY OR NEGATIVELY AMEND, EXTEND OR ALTER THE COVERAGE AFFORDED BY THE POLICIES BELOW. THIS CERTIFICATE OF INSURANCE DOES NOT CONSTITUTE A CONTRACT BETWEEN THE ISSUING INSURER(S), AUTHORIZED REPRESENTATIVE OR PRODUCER, AND THE CERTIFICATE HOLDER.

IMPORTANT: If the certificate holder is an ADDITIONAL INSURED, the policy(ies) must have ADDITIONAL INSURED provisions or be endorsed. If SUBROGATION IS WAIVED, subject to the terms and conditions of the policy, certain policies may require an endorsement. A statement on this certificate does not confer rights to the certificate holder in lieu of such endorsement(s).

PRODUCER Willis Towers Watson Northeast, Inc. c/o 26 Century Blvd P.O. Box 305191 Nashville, TN 372305191 USA	CONTACT NAME: WTW Certificate Center PHONE (A/C. No. Ext): 1-877-945-7378 FAX (A/C. No): 1-888-467-2378 E-MAIL ADDRESS: certificates@wtwco.com	
	INSURER(S) AFFORDING COVERAGE INSURER A: Tokio Marine America Insurance Company INSURER B: Sompo America Insurance Company INSURER C: Sompo America Fire & Marine Insurance Comp INSURER D: INSURER E: INSURER F:	NAIC # 10945 11126 38997
INSURED Canon Solutions America, Inc. One Canon Park Melville, NY 11747		

COVERAGES

CERTIFICATE NUMBER: W33522719

REVISION NUMBER:

THIS IS TO CERTIFY THAT THE POLICIES OF INSURANCE LISTED BELOW HAVE BEEN ISSUED TO THE INSURED NAMED ABOVE FOR THE POLICY PERIOD INDICATED. NOTWITHSTANDING ANY REQUIREMENT, TERM OR CONDITION OF ANY CONTRACT OR OTHER DOCUMENT WITH RESPECT TO WHICH THIS CERTIFICATE MAY BE ISSUED OR MAY PERTAIN, THE INSURANCE AFFORDED BY THE POLICIES DESCRIBED HEREIN IS SUBJECT TO ALL THE TERMS, EXCLUSIONS AND CONDITIONS OF SUCH POLICIES. LIMITS SHOWN MAY HAVE BEEN REDUCED BY PAID CLAIMS.

INSR LTR	TYPE OF INSURANCE	ADDL INSD	SUBR WVD	POLICY NUMBER	POLICY EFF (MM/DD/YYYY)	POLICY EXP (MM/DD/YYYY)	LIMITS
A	<input checked="" type="checkbox"/> COMMERCIAL GENERAL LIABILITY <input type="checkbox"/> CLAIMS-MADE <input checked="" type="checkbox"/> OCCUR GEN'L AGGREGATE LIMIT APPLIES PER: <input type="checkbox"/> POLICY <input type="checkbox"/> PRO-JECT <input checked="" type="checkbox"/> LOC OTHER:			GLD6404741-13	11/01/2023	11/01/2024	EACH OCCURRENCE \$ 1,000,000 DAMAGE TO RENTED PREMISES (Ea occurrence) \$ 1,000,000 MED EXP (Any one person) \$ 5,000 PERSONAL & ADV INJURY \$ 1,000,000 GENERAL AGGREGATE \$ 2,000,000 PRODUCTS - COMP/OP AGG \$ 1,000,000
B	AUTOMOBILE LIABILITY <input checked="" type="checkbox"/> ANY AUTO <input type="checkbox"/> OWNED AUTOS ONLY <input type="checkbox"/> SCHEDULED AUTOS <input type="checkbox"/> HIRED AUTOS ONLY <input type="checkbox"/> NON-OWNED AUTOS ONLY			AAL30026136801	11/01/2023	11/01/2024	COMBINED SINGLE LIMIT (Ea accident) \$ 1,000,000 BODILY INJURY (Per person) \$ BODILY INJURY (Per accident) \$ PROPERTY DAMAGE (Per accident) \$ Comp/Coll \$ 1,000.00
	UMBRELLA LIAB EXCESS LIAB OCCUR CLAIMS-MADE DED RETENTION \$						EACH OCCURRENCE \$ AGGREGATE \$
C	WORKERS COMPENSATION AND EMPLOYERS' LIABILITY ANY PROPRIETOR/PARTNER/EXECUTIVE OFFICER/MEMBER EXCLUDED? (Mandatory in NH) If yes, describe under DESCRIPTION OF OPERATIONS below	Y/N No	N/A	JCD40017R0	11/01/2023	11/01/2024	<input checked="" type="checkbox"/> PER STATUTE OTH-ER E.L. EACH ACCIDENT \$ 1,000,000 E.L. DISEASE - EA EMPLOYEE \$ 1,000,000 E.L. DISEASE - POLICY LIMIT \$ 1,000,000

DESCRIPTION OF OPERATIONS / LOCATIONS / VEHICLES (ACORD 101, Additional Remarks Schedule, may be attached if more space is required)
City of Spokane, its officers and employees are included as Additional Insureds as respects to General Liability where required by written contract.

CERTIFICATE HOLDER

CANCELLATION

City of Spokane
 808 W Spokane Falls Blvd
 Spokane, WA 99201

SHOULD ANY OF THE ABOVE DESCRIBED POLICIES BE CANCELLED BEFORE THE EXPIRATION DATE THEREOF, NOTICE WILL BE DELIVERED IN ACCORDANCE WITH THE POLICY PROVISIONS.

AUTHORIZED REPRESENTATIVE
Patricia A Jony

© 1988-2016 ACORD CORPORATION. All rights reserved.



STATE OF WASHINGTON

BUSINESS LICENSE

Profit Corporation

CANON SOLUTIONS AMERICA, INC.
CANON SOLUTIONS AMERICA, INC..
300 COMMERCE SQUARE BLVD
BURLINGTON NJ 08016-1270

UNEMPLOYMENT INSURANCE - ACTIVE
TAX REGISTRATION - ACTIVE

INDUSTRIAL INSURANCE - ACTIVE

Issue Date: Jan 19, 2024

Unified Business ID #: 602493129

Business ID #: 001

Location: 0001

Expires: Jan 31, 2025

CITY/COUNTY ENDORSEMENTS:

- KELSO GENERAL BUSINESS - NON-RESIDENT #A040148 - ACTIVE
- ELLENSBURG GENERAL BUSINESS - NON-RESIDENT #14330 - ACTIVE
- PASCO GENERAL BUSINESS - NON-RESIDENT #18187 - ACTIVE
- CENTRALIA GENERAL BUSINESS - NON-RESIDENT #10677 - ACTIVE
- SHELTON GENERAL BUSINESS - NON-RESIDENT #0048250 - ACTIVE
- BELLINGHAM GENERAL BUSINESS #051843 - ACTIVE
- ISSAQUAH GENERAL BUSINESS - NON-RESIDENT - ACTIVE
- KENNEWICK GENERAL BUSINESS - NON-RESIDENT - ACTIVE
- LACEY GENERAL BUSINESS - NON-RESIDENT #22237 - ACTIVE
- LONGVIEW GENERAL BUSINESS - NON-RESIDENT #110682 - ACTIVE
- MARYSVILLE GENERAL BUSINESS - NON-RESIDENT #6454RET613 - ACTIVE
- OLYMPIA GENERAL BUSINESS - NON-RESIDENT #25776 - ACTIVE
- SPOKANE VALLEY GENERAL BUSINESS - NON-RESIDENT - ACTIVE
- SUMNER GENERAL BUSINESS - NON-RESIDENT - ACTIVE
- TUMWATER GENERAL BUSINESS - NON-RESIDENT #R-011962 - ACTIVE

This document lists the registrations, endorsements, and licenses authorized for the business named above. By accepting this document, the licensee certifies the information on the application was complete, true, and accurate to the best of his or her knowledge, and that business will be conducted in compliance with all applicable Washington state, county, and city regulations.

Director, Department of Revenue

UBI: 602493129 001 0001

STATE OF WASHINGTON

Expires: Jan 31, 2025

CANON SOLUTIONS AMERICA, INC.
CANON SOLUTIONS AMERICA, INC..
300 COMMERCE SQUARE BLVD
BURLINGTON NJ 08016-1270

UNEMPLOYMENT INSURANCE - ACTIVE
INDUSTRIAL INSURANCE - ACTIVE
TAX REGISTRATION - ACTIVE
KELSO GENERAL BUSINESS - NON-RESIDENT #A040148 - ACTIVE
ELLENSBURG GENERAL BUSINESS - NON-RESIDENT #14330 - ACTIVE
PASCO GENERAL BUSINESS - NON-RESIDENT #18187 - ACTIVE
CENTRALIA GENERAL BUSINESS - NON-RESIDENT #10677 - ACTIVE
SHELTON GENERAL BUSINESS - NON-RESIDENT #0048250 - ACTIVE
BELLINGHAM GENERAL BUSINESS

Director, Department of Revenue



STATE OF WASHINGTON

BUSINESS LICENSE

Profit Corporation

CANON SOLUTIONS AMERICA, INC.
CANON SOLUTIONS AMERICA, INC..
300 COMMERCE SQUARE BLVD
BURLINGTON NJ 08016-1270

CITY/COUNTY ENDORSEMENTS:

- SPOKANE GENERAL BUSINESS - NON-RESIDENT - ACTIVE
- TUKWILA GENERAL BUSINESS - NON-RESIDENT - ACTIVE
- MERCER ISLAND GENERAL BUSINESS - NON-RESIDENT #130051 - ACTIVE
- LYNNWOOD GENERAL BUSINESS - NON-RESIDENT #018768-03-2016 - ACTIVE
- YAKIMA GENERAL BUSINESS - NON-RESIDENT #BL079912 - ACTIVE
- BURIEN GENERAL BUSINESS - NON-RESIDENT #10088 - ACTIVE
- NACHES GENERAL BUSINESS - NON-RESIDENT #006072.00 - ACTIVE
- ABERDEEN GENERAL BUSINESS - NON-RESIDENT #214857 - ACTIVE
- BREMERTON GENERAL BUSINESS - NON-RESIDENT #29919 - ACTIVE
- BOTHELL GENERAL BUSINESS - NON-RESIDENT #5380 - ACTIVE

LICENSING RESTRICTIONS:

Aberdeen city license valid until canceled by either party.

Not licensed to hire minors without a Minor Work Permit.

Issue Date: Jan 19, 2024

Unified Business ID #: 602493129

Business ID #: 001

Location: 0001

Expires: Jan 31, 2025

This document lists the registrations, endorsements, and licenses authorized for the business named above. By accepting this document, the licensee certifies the information on the application was complete, true, and accurate to the best of his or her knowledge, and that business will be conducted in compliance with all applicable Washington state, county, and city regulations.

Director, Department of Revenue

UBI: 602493129 001 0001

CANON SOLUTIONS AMERICA, INC.
CANON SOLUTIONS AMERICA, INC..
300 COMMERCE SQUARE BLVD
BURLINGTON NJ 08016-1270

STATE OF WASHINGTON

- UNEMPLOYMENT INSURANCE - ACTIVE
- INDUSTRIAL INSURANCE - ACTIVE
- TAX REGISTRATION - ACTIVE
- KELSO GENERAL BUSINESS - NON-RESIDENT #A040148 - ACTIVE
- ELLENSBURG GENERAL BUSINESS - NON-RESIDENT #14330 - ACTIVE
- PASCO GENERAL BUSINESS - NON-RESIDENT #18187 - ACTIVE
- CENTRALIA GENERAL BUSINESS - NON-RESIDENT #10677 - ACTIVE
- SHELTON GENERAL BUSINESS - NON-RESIDENT #0048250 - ACTIVE
- BELLINGHAM GENERAL BUSINESS

Expires: Jan 31, 2025

Director, Department of Revenue

IMPORTANT!

PLEASE READ THE FOLLOWING INFORMATION CAREFULLY BEFORE POSTING THIS LICENSE

General Information

Post this Business License in a visible location at your place of business.

If you were issued a Business License previously, **destroy the old one and post this one in its place.**

Login to My DOR at dor.wa.gov if you need to make changes to your business name, location, mailing address, telephone number, or business ownership.

Telephone: 360-705-6741

Endorsements

All endorsements should be renewed by the expiration date that appears on the front of this license to avoid any late fees.

If there is no expiration date, the endorsements remain active as long as you continue required reporting. Tax Registration, Unemployment Insurance, and Industrial Insurance endorsements require you to submit periodic reports. Each agency will send you the necessary reporting forms and instructions.

For assistance or to request this document in an alternate format, visit <http://business.wa.gov/BLS> or call (360) 705-6741. Teletype (TTY) users may use the Washington Relay Service by calling 711.

BLS-700-107 (07/27/20)

**Agenda Sheet for City Council:****Committee:** Finance & Administration **Date:** 07/22/2024**Committee Agenda type:** Consent**Date Rec'd**

7/24/2024

Clerk's File #

OPR 2024-0612

Cross Ref #**Project #****Council Meeting Date:** 08/12/2024**Submitting Dept**

INFORMATION TECHNOLOGY

Bid #**Contact Name/Phone**

MICHAEL 625-6468

Requisition #

CR 26480

Contact E-Mail

MSLOON@SPOKANECITY.ORG

Agenda Item Type

Contract Item

Council Sponsor(s)

MCATHCART BWILKERSON ZZAPPONE

Agenda Item Name

5300 – 5-YEAR LEASE OF MAIL AND INSERTER MACHINES, AND ASSOC.

Agenda Wording

Quadient Leasing USA, Inc. (Milford, CT) was selected for lease of Mail and Inserter Machines, and assoc. softwares for the Mail Center. Total lease term is September 24, 2024, through September 23, 2029.

Summary (Background)

This equipment and software is utilized for processing, inserting, and mailing approx 80000 utility bills each month. The mailing software cleans addresses and sorts mail pieces into mailings that meet the USPS mailing requirements. The inserter machine feeds mail pieces into the machine, folds the pages, adds any inserts or return envelopes, and inserts all pieces into an envelope. The mailing machine then adds postage to all mail pieces sent out by different city departments.

Lease? YES

Grant related? NO

Public Works? NO

Fiscal Impact

Approved in Current Year Budget? YES

Total Cost

\$ 236,987.40 for five years plus applicable tax

Current Year Cost

\$ 51,663.25 including tax

Subsequent Year(s) Cost

\$

Narrative

The existing mailing and inserter machine lease for the Mail Center is expiring. This new lease with Quadient Leasing USA, replaces that expiring lease.

Amount**Budget Account**

Expense

\$ 12,784.06

5300-73700-18880-54501 2024 budget

Expense

\$ 1,956.19

5300-73700-18850-54804 2024 budget

Expense

\$ 2,480.84

5300-73700-18850-54820 2024 budget

Expense

\$ 38,352.17

5300-73700-18880-54501 2025 budget

Expense

\$ 5,868.56

5300-73700-18850-54804 2025 budget

Expense

\$ 7,442.52

5300-73700-18850-54820 2025 budget



Continuation of Wording, Summary, Approvals, and Distribution

Agenda Wording

The total lease amount for five (5) years will be \$236,987.40 plus applicable tax.

Summary (Background)

Additional Fiscal Impact Lines: Expense 38,352.17 5300-73700-18880-54501 2026 budget Expense 5,868.56 5300-73700-18850-54804 2026 budget Expense 7,442.52 5300-73700-18850-54820 2026 budget Expense 38,352.17 5300-73700-18880-54501 2027 budget Expense 5,868.56 5300-73700-18850-54804 2027 budget Expense 7,442.52 5300-73700-18850-54820 2027 budget Expense 38,352.17 5300-73700-18880-54501 2028 budget Expense 5,868.56 5300-73700-18850-54804 2028 budget Expense 7,442.52 5300-73700-18850-54820 2028 budget Expense 25,568.11 5300-73700-18880-54501 2029 budget Expense 3,912.37 5300-73700-18850-54804 2029 budget Expense 4,961.68 5300-73700-18850-54820 2029 budget

Approvals

<u>Dept Head</u>	MARTINEZ, LAZ
<u>Division Director</u>	SLOON, MICHAEL
<u>Accounting Manager</u>	BUSTOS, KIM
<u>Legal</u>	SZAMBELAN, TIMOTHY
<u>For the Mayor</u>	PICCOLO, MIKE

Additional Approvals

<u>PURCHASING</u>	NECHANICKY, JASON
<u>ACCOUNTING -</u>	BAIRD, CHRISTI

Distribution List

John Tartaro – j.tartaro@quadiant.com	Accounting - ywang@spokanecity.org
Contract Accounting - ddaniels@spokanecity.org	Legal - mharrington@spokanecity.org
Purchasing - cwahl@spokanecity.org	IT - itadmin@spokanecity.org
Tax & Licenses	

Committee Agenda Sheet

Finance & Administration Committee

Committee Date	July 22, 2024
Submitting Department	IT
Contact Name	Mike Sloon
Contact Email & Phone	msloon@spokanecity.org , 509-625-6468
Council Sponsor(s)	<u>CM Cathcart, CP Wilkerson, CM Zappone</u>
Select Agenda Item Type	<input checked="" type="checkbox"/> Consent <input type="checkbox"/> Discussion Time Requested:
Agenda Item Name	5300 – 5-year Lease of Mail and Inserter Machines, and assoc. softwares for the Mail Center
Proposed Council Action	<input checked="" type="checkbox"/> Approval to proceed to Legislative Agenda <input type="checkbox"/> Information Only
Summary (Background) *use the Fiscal Impact box below for relevant financial information	<p>Quadient Leasing USA, Inc. (Milford, CT) was selected for lease of Mail and Inserter Machines, and assoc. softwares for the Mail Center.</p> <p>This equipment and software is utilized for processing, inserting, and mailing approximately 80000 utility bills each month. The mailing software cleans addresses and sorts mail pieces into mailings that meet the United States Postal Services mailing requirements. The inserter machine feeds mail pieces into the machine, folds the pages, adds any inserts or return envelopes, and inserts all pieces into an envelope. The mailing machine then adds postage to all mail pieces sent out by different city departments.</p> <p>While the primary use is for utility bills, this software and equipment are also used for a variety of other departmental mailings throughout the city. The Mail Center uses the software to create mailings for other departments, such as Engineering, the City Clerk’s Office, Parks, and Hillyard Senior Center. The Mail Center inserts and mails letters, checks, and other documents for DSC, Water, Accounting, and Treasury. Not including utility bills, the mail machine is used to add postage to roughly 500 mail pieces each business day. This lease is for five (5) years. Lease payment includes, as applicable, reduced price equipment maintenance to reflect first year free, meter rental, meter resets, postal rate changes, software license/support/subscription fees, delivery, installation, and operator training. Total lease term is September 24, 2024, through September 23, 2029.</p> <p>The first-year lease amount is \$47,397.48 plus tax and will be billed quarterly.</p> <p>5300-73700-18880-54501 = \$35,185.48 plus tax = \$38,352.17 5300-73700-18850-54804 = \$ 5,384.00 plus tax = \$ 5,868.56 5300-73700-18850-54820 = <u>\$ 6,828.00 plus tax = \$ 7,442.52</u> \$47,397.48 plus tax = \$51,663.25</p> <p>Current expiring lease yearly amount is \$49,734.40.</p> <p>The total lease amount for five (5) years will be \$236,987.40 plus applicable tax.</p>

Fiscal Impact

Approved in current year budget? Yes No N/A

Total Cost: \$236,987.40 for five years plus applicable tax.

Current year cost: \$51,663.25 including tax

Subsequent year(s) cost:

Narrative: The existing mailing and inserter machine lease for the Mail Center is expiring. This new lease with Quadient Leasing USA, replaces that expiring lease. The City is utilizing NASPO/ValuePoint Contract #: CTR058809 and/or State Participating Addendum (PA) #: 15622-02 (WA) to obtain the best pricing.

Funding Source One-time Recurring N/A

Specify funding source: Select Funding Source*

Is this funding source sustainable for future years, months, etc? [Click or tap here to enter text.](#)

Expense Occurrence One-time Recurring N/A

Other budget impacts: (revenue generating, match requirements, etc.)

Operations Impacts (If N/A, please give a brief description as to why)

What impacts would the proposal have on historically excluded communities?

Not applicable

How will data be collected, analyzed, and reported concerning the effect of the program/policy by racial, ethnic, gender identity, national origin, income level, disability, sexual orientation, or other existing disparities?

Not applicable

How will data be collected regarding the effectiveness of this program, policy or product to ensure it is the right solution?

Not applicable

Describe how this proposal aligns with current City Policies, including the Comprehensive Plan, Sustainability Action Plan, Capital Improvement Program, Neighborhood Master Plans, Council Resolutions, and others?

This service aligns with the Sustainable Resources strategic initiative based on sound financial objectives, and quality customer service by providing a stable and current mailing center infrastructure.



City of Spokane
CONTRACT
**LEASE OF MAIL AND INSERTER
MACHINES, AND ASSOCIATED SOFTWARE**

THIS CONTRACT is between the **CITY OF SPOKANE** as (“City”), a Washington municipal corporation, and **QUADIENT LEASING USA, INC.**, whose address is 478 Wheelers Farms Road, Milford CT 06461, payment address is Quadient Leasing USA, Inc., Dept 3682, PO Box 123682, Dallas TX 75312-3682, as (“Company”), individually hereafter referenced as a “party”, and together as the “parties”.

The parties agree as follows:

1. **PERFORMANCE.** The Company will Lease a Mail and Inserter Machines and associated software and provide Service, Parts and Labor and pick up of the equipment at the end of the lease, in accordance with the Purchase Order - Lease, attached as Exhibit B. Company was selected through Utilizing NASPO/ValuePoint Contract #: CTR058809 and/or State Participating Addendum (PA) #: 15622-02 (WA). In the event of a discrepancy between the documents this City Contract controls.
2. **CONTRACT TERMS.** The Contract shall begin September 24, 2024, and run through September 23, 2029, unless amended by written agreement or terminated earlier under the provisions.
3. **COMPENSATION.** Total compensation under this Contract shall not exceed **TWO HUNDRED THIRTY-SIX THOUSAND NINE HUNDRED EIGHTY-SEVEN AND 40/100 DOLLARS (\$236,987.40)**, plus applicable sales tax; billed quarterly, for everything furnished and done under this Contract. This is the maximum amount to be paid under this Contract for the work described in Section 1 above, and shall not be exceeded without the prior written authorization of the City in the form of an executed amendment to this Contract.
4. **PAYMENT.** The Company shall send its application for payment to Information Technology, Administration Office, Seventh Floor, City Hall, 808 West Spokane Falls Boulevard, Spokane, Washington 99201. **Payment will be made via direct deposit/ACH** within thirty (30) days after receipt of the Company’s application except as provided by state law.
5. **COMPLIANCE WITH LAWS.** Each party shall comply with all applicable federal, state, and local laws and regulations.
6. **ASSIGNMENTS.** This Contract is binding on the parties and their heirs, successors, and assigns. Neither party may assign, transfer or subcontract its interest, in whole or in part, without the other party's prior written consent.

7. AMENDMENTS. This Contract may be amended at any time by mutual written agreement.

8. ANTI-KICKBACK. No officer or employee of the City of Spokane, having the power or duty to perform an official act or action related to this Contract shall have or acquire any interest in the Contract, or have solicited, accepted or granted a present or future gift, favor, service or other thing of value from or to any person involved in this Contract.

9. TERMINATION. Either party may terminate this Contract by thirty (30) days' written notice to the other party. In the event of such termination, the City shall pay the Company for all work previously authorized and performed prior to the termination date. Termination is pursuant to NASPO contract - Equipment lease agreement terms and conditions included in the Master agreement and attached herein have been approved for use by the Participating State. The termination or expiration of the Master Agreement or this PA shall in no way relieve any individual entity from its obligations to any product leases or postage meter rental agreements that were entered prior to the date of any such termination.

10. INSURANCE. During the term of the Agreement, the Company shall maintain in force at its own expense, the following insurance coverages:

- A. Worker's Compensation Insurance in compliance with RCW 51.12.020, which requires subject employers to provide workers' compensation coverage for all their subject workers; and
- B. General Liability Insurance on an occurrence basis, with a combined single limit of not less than \$1,000,000 each occurrence for bodily injury and property damage. It shall include contractual liability coverage for the indemnity provided under this contract. It shall provide that the City, its officers and employees are additional insureds, but only with respect to the Company's services to be provided under this contract;
 - i. Acceptable supplementary Umbrella insurance coverage, combined with the Company's General Liability insurance policy must be a *minimum* of \$1,000,000, in order to meet the insurance coverages required under this Contract;
- C. Automobile Liability Insurance with a combined single limit, or the equivalent of not less than \$1,000,000 each accident for bodily injury and property damage, including coverage for owned, hired and non-owned vehicles.

There shall be no cancellation, material change, reduction of limits or intent not to renew the insurance coverage(s) without sixty (60) days written notice from the Company or its insurer(s) to the City. As evidence of the insurance coverage(s) required by this Agreement, the Company shall furnish acceptable Certificates of Insurance (COI) to the City at the time it returns this signed Agreement. **The certificate shall specify the City of Spokane as "Additional Insured"** specifically for Company's services under this Agreement, as well as all of the parties who are additional insureds, and include applicable policy endorsements, the sixty (60) day cancellation clause, and the deduction or retention level. The Company shall be financially responsible for all pertinent deductibles, self-insured retentions, and/or self-insurance.

11. INDEMNIFICATION. The Company shall defend, indemnify, and hold the City and its officers and employees harmless from all claims, demands, or suits at law or equity asserted by third parties for bodily injury (including death) and/or property damage which arise from the

Company's negligence or willful misconduct under this Agreement, including attorneys' fees and litigation costs; provided that nothing herein shall require a Company to indemnify the City against and hold harmless the City from claims, demands or suits based solely upon the negligence of the City, its agents, officers, and employees. If a claim or suit is caused by or results from the concurrent negligence of the Company's agents or employees and the City, its agents, officers and employees, this indemnity provision shall be valid and enforceable to the extent of the negligence of the Company, its agents or employees. The Company specifically assumes liability and agrees to defend, indemnify, and hold the City harmless for actions brought by the Company's own employees against the City and, solely for the purpose of this indemnification and defense, the Company specifically waives any immunity under the Washington State industrial insurance law, or Title 51 RCW. The Company recognizes that this waiver was specifically entered into pursuant to the provisions of RCW 4.24.115 and was the subject of mutual negotiation. The indemnity and agreement to defend and hold the City harmless provided for in this section shall survive any termination or expiration of this agreement.

12. DEBARMENT AND SUSPENSION. The Company has provided its certification that it is in compliance with and shall not contract with individuals or organizations which are debarred, suspended, or otherwise excluded from or ineligible from participation in Federal Assistance Programs under Executive Order 12549 and "Debarment and Suspension", codified at 29 CFR part 98.

13. SEVERABILITY. In the event any provision of this Contract should become invalid, the rest of the Contract shall remain in full force and effect.

14. STANDARD OF PERFORMANCE. The silence or omission in the Contract regarding any detail required for the proper performance of the work, means that the Company shall perform the best general practice.

15. NONDISCRIMINATION. No individual shall be excluded from participation in, denied the benefit of, subjected to discrimination under, or denied employment in the administration of or in connection with this Contract because of age, sex, race, color, religion, creed, marital status, familial status, sexual orientation including gender expression or gender identity, national origin, honorably discharged veteran or military status, the presence of any sensory, mental or physical disability, or use of a service animal by a person with disabilities. The Company agrees to comply with, and to require that all subcontractors comply with, Section 504 of the Rehabilitation Act of 1973 and the Americans with Disabilities Act, as applicable to the Company.

16. BUSINESS REGISTRATION REQUIREMENT. Section 8.01.070 of the Spokane Municipal Code states that no person may engage in business with the City without first having obtained a valid annual business registration. The Company shall be responsible for contacting the State of Washington Business License Services at www.dor.wa.gov or 360-705-6741 to obtain a business registration. If the Company does not believe it is required to obtain a business registration, it may contact the City's Taxes and Licenses Division at (509) 625-6070 to request an exemption status determination.

17. AUDIT / RECORDS. The Company and its subcontractors shall maintain for a minimum of three (3) years following final payment all records related to its performance of the Contract. The Company and its subcontractors shall provide access to authorized City representatives, at reasonable times and in a reasonable manner to inspect and copy any such record. In the event of conflict between this provision and related auditing provisions required under federal law applicable to the Contract, the federal law shall prevail.

18. CONFIDENTIALITY/PUBLIC RECORDS. Notwithstanding anything to the contrary, City will maintain the confidentiality of Company's materials and information only to the extent that is legally allowed in the State of Washington. City is bound by the State Public Records Act, RCW Ch. 42.56. That law presumptively makes all records in the possession of the City public records which are freely available upon request by anyone. In the event that City gets a valid public records request for Company's materials or information and the City determines there are exemptions only the Company can assert, City will endeavor to give Company notice. Company, at its own expense, will be required to go to Court to get an injunction preventing the release of the requested records. In the event that Company does not get a timely injunction preventing the release of the records, the City will comply with the Public Records Act and release the records.

19. DISPUTES. This Contract shall be performed under the laws of the State of Washington. Any litigation to enforce this Contract or any of its provisions shall be brought in Spokane County, Washington.

QUADIENT LEASING USA, INC.

CITY OF SPOKANE

By _____
Signature Date

By _____
Signature Date

Type or Print Name

Type or Print Name

Title

Title

Attest:

Approved as to form:

City Clerk

Assistant City Attorney

Attachments that are part of this Agreement:
Exhibit A – Certificate Regarding Debarment
Exhibit B – Purchase Order - Lease

**EXHIBIT A
CERTIFICATION REGARDING DEBARMENT, SUSPENSION,
INELIGIBILITY AND VOLUNTARY EXCLUSION**

1. The undersigned (i.e., signatory for the Subrecipient / Contractor / Consultant) certifies, to the best of its knowledge and belief, that it and its principals:
 - a. Are not presently debarred, suspended, proposed for debarment, declared ineligible, or voluntarily excluded from covered transactions by any federal department or agency;
 - b. Have not within a three-year period preceding this contract been convicted or had a civil judgment rendered against them for commission of fraud or a criminal offense in connection with obtaining, attempting to obtain, or performing a public (federal, state, or local) transaction or contract under a public transaction; violation of federal or state antitrust statutes or commission of embezzlement, theft, forgery, bribery, falsification or destruction of records, making false statements, tax evasion, receiving stolen property, making false claims, or obstruction of justice;
 - c. Are not presently indicted or otherwise criminally or civilly charged by a government entity (federal, state, or local) with commission of any of the offenses enumerated in paragraph (1)(b) of this certification; and,
 - d. Have not within a three-year period preceding this contract had one or more public transactions (federal, state, or local) terminated for cause or default.

2. The undersigned agrees by signing this contract that it shall not knowingly enter into any lower tier covered transaction with a person who is debarred, suspended, declared ineligible, or voluntarily excluded from participation in this covered transaction.

3. The undersigned further agrees by signing this contract that it will include the following clause, without modification, in all lower tier covered transactions and in all solicitations for lower tier covered transactions:

Certification Regarding Debarment, Suspension, Ineligibility and Voluntary Exclusion – Lower Tier Covered Transactions

1. The lower tier contractor certified, by signing this contract that neither it nor its principals is presently debarred, suspended, proposed for debarment, declared ineligible, or voluntarily excluded from participation in this transaction by any federal department or agency.

 2. Where the lower tier contractor is unable to certify to any of the statements in this contract, such contractor shall attach an explanation to this contract.
4. I understand that a false statement of this certification may be grounds for termination of the contract.

<hr style="border: none; border-top: 1px solid black; margin-bottom: 5px;"/> Name of Subrecipient / Contractor / Consultant (Type or Print)	<hr style="border: none; border-top: 1px solid black; margin-bottom: 5px;"/> Program Title (Type or Print)
<hr style="border: none; border-top: 1px solid black; margin-bottom: 5px;"/> Name of Certifying Official (Type or Print)	<hr style="border: none; border-top: 1px solid black; margin-bottom: 5px;"/> Signature
<hr style="border: none; border-top: 1px solid black; margin-bottom: 5px;"/> Title of Certifying Official (Type or Print)	<hr style="border: none; border-top: 1px solid black; margin-bottom: 5px;"/> Date (Type or Print)

EXHIBIT B

Customer

Organization	CITY OF SPOKANE		
DBA			
Address	808 W SPOKANE FALLS BLVD		
City State Zip	SPOKANE	WA	99201
Phone	(509) 625-6477	Fax	

Purchase Order - Lease

NASPO/ValuePoint Contract #: CTR058809
 and / or
 State Participating Addendum (PA) #:
 15622-02 (WA)

Vendor

Company Name	Quadient Leasing USA Inc.	FEDERAL ID#	94-2984524
Attention	Government Sales	DUNS#	150836872
Address	478 Wheelers Farms Rd		
City State Zip	Milford	CT	06461
Phone	(866) 448-0045	Fax	(203) 301-2600

Ship To

Organization	CITY OF SPOKANE		
Attention	T.C. BRENDEN		
Address	808 W SPOKANE FALLS BLVD		
City State Zip	SPOKANE	WA	99201
Phone	(509) 625-6477	Email	tbrenden@spokanecity.org

P.O. Number	P.O. Date	Requisitioner	Shipped Via	F.O.B. Point	Terms
			Ground	Destination	Quarterly Invoicing
QTY	Unit	Description	Unit Price	Total	
60	Months	Lease Payment	\$3,949.79	\$236,987.40	

Lease payment specified above for products listed below includes, as applicable, reduced price equipment maintenance to reflect first year free, meter rental, meter resets, postal rate changes, software license/support/subscription fees, delivery, installation, and operator training.

Products

QTY	Product ID	Description
1	IDA-PS	NORAM IDA Professional Services
1	50001-COR-PROLM	Automate Pro License (5M clicks/pages per year)
1	DS180I3ST	3 Station Tower, Accumulate & Divert, Conveyor, Furniture and AIMS On Board
4	USAOMS-100K-NCOARE	Automate plug-in NCOA - RENEWAL (1.2M credits/year)
4	USAOMS-100K-RE	Automate plug-in - RENEWAL (60-100K mailpieces/month)
2	DS18DBREFURN	Double BRE Insert Feeder with Furniture
1	IX7ERR	iX-7 Series Base e-RR Feature & Activation Kit w/bc scanner. Inc e-RR SW & Rate File w/200 eDel/Sig C
1	IXPWRSTACKER	Conveyor Stacker & Adaptor (IX7 & IX7PRO ONLY)
1	DS180ICISFDB	Tower Folder CIS Face Down Bottom Position
1	DS180IMULTLIC	Tower Folder Multi Read License
1	USAOMS-100K-NCOA	Automate plug-in NCOA (1.2M credits/year)
1	IXDS7	Dynamic Weighing Platform for IX Series 7/7PRO Bases
1	50001MC0	Mail Connector - Connects to AIMS - BCC
1	USAOMS-100K	Automate plug-in (60-100K mailpieces/month)
1	SMARTIX7WP70	iX-7; 10lb WP + 70lb Ship Scale w/Display; All-in-One PC; Zebra Label Printer; SMART Mail Center SW w
1	SMARTCOMPSTAND	S.M.A.R.T. Computer Stand for All-In-One PC, Full Wireless Keyboard & Mouse
1	SMART-REM-CONFIG	S.M.A.R.T. Remote Configuration Training

1) Order is governed under the terms and conditions of the NASPO/ValuePoint Master Price Agreement Contract Number CTR058809. Enter this order in accordance with the prices, terms, delivery method, and specifications listed above.

2) Payments will be sent to:
 Quadient Leasing USA, Inc.
 Dept 3682
 PO Box 123682
 Dallas TX 75312-3682

3) Send all correspondence to:
 Quadient Leasing USA, Inc.
 478 Wheelers Farms Rd
 Milford CT 06461
 Phone: 203-301-3400
 Fax: 203-301-2600

_____	_____
Authorized by	Date
_____	_____
Print Name	Title



CERTIFICATE OF LIABILITY INSURANCE

DATE (MM/DD/YYYY)
05/08/2024

THIS CERTIFICATE IS ISSUED AS A MATTER OF INFORMATION ONLY AND CONFERS NO RIGHTS UPON THE CERTIFICATE HOLDER. THIS CERTIFICATE DOES NOT AFFIRMATIVELY OR NEGATIVELY AMEND, EXTEND OR ALTER THE COVERAGE AFFORDED BY THE POLICIES BELOW. THIS CERTIFICATE OF INSURANCE DOES NOT CONSTITUTE A CONTRACT BETWEEN THE ISSUING INSURER(S), AUTHORIZED REPRESENTATIVE OR PRODUCER, AND THE CERTIFICATE HOLDER.

IMPORTANT: If the certificate holder is an ADDITIONAL INSURED, the policy(ies) must have ADDITIONAL INSURED provisions or be endorsed. If SUBROGATION IS WAIVED, subject to the terms and conditions of the policy, certain policies may require an endorsement. A statement on this certificate does not confer rights to the certificate holder in lieu of such endorsement(s).

PRODUCER Willis Towers Watson Northeast, Inc. c/o 26 Century Blvd P.O. Box 305191 Nashville, TN 372305191 USA	CONTACT NAME: WTW Certificate Center PHONE (A/C. No. Ext): 1-877-945-7378 E-MAIL ADDRESS: certificates@wtwco.com		FAX (A/C. No.): 1-888-467-2378
	INSURER(S) AFFORDING COVERAGE INSURER A: XL Insurance America Inc		NAIC # 24554
INSURED Quadient, Inc. 478 Wheelers Farms Rd Milford, CT 06461	INSURER B:		
	INSURER C:		
	INSURER D:		
	INSURER E:		
	INSURER F:		

COVERAGES**CERTIFICATE NUMBER:** W33518246**REVISION NUMBER:**

THIS IS TO CERTIFY THAT THE POLICIES OF INSURANCE LISTED BELOW HAVE BEEN ISSUED TO THE INSURED NAMED ABOVE FOR THE POLICY PERIOD INDICATED. NOTWITHSTANDING ANY REQUIREMENT, TERM OR CONDITION OF ANY CONTRACT OR OTHER DOCUMENT WITH RESPECT TO WHICH THIS CERTIFICATE MAY BE ISSUED OR MAY PERTAIN, THE INSURANCE AFFORDED BY THE POLICIES DESCRIBED HEREIN IS SUBJECT TO ALL THE TERMS, EXCLUSIONS AND CONDITIONS OF SUCH POLICIES. LIMITS SHOWN MAY HAVE BEEN REDUCED BY PAID CLAIMS.

INSR LTR	TYPE OF INSURANCE	ADDL INSD	SUBR VVD	POLICY NUMBER	POLICY EFF (MM/DD/YYYY)	POLICY EXP (MM/DD/YYYY)	LIMITS	
A	<input checked="" type="checkbox"/> COMMERCIAL GENERAL LIABILITY <input type="checkbox"/> CLAIMS-MADE <input checked="" type="checkbox"/> OCCUR	Y	Y	US00108254LI24A	04/01/2024	04/01/2025	EACH OCCURRENCE	\$ 2,000,000
	<input checked="" type="checkbox"/> Contractual Liability						DAMAGE TO RENTED PREMISES (Ea occurrence)	\$ 50,000
	GEN'L AGGREGATE LIMIT APPLIES PER: <input checked="" type="checkbox"/> POLICY <input checked="" type="checkbox"/> PRO-JECT <input type="checkbox"/> LOC						MED EXP (Any one person)	\$ 10,000
	OTHER:						PERSONAL & ADV INJURY	\$ 2,000,000
	AUTOMOBILE LIABILITY						COMBINED SINGLE LIMIT (Ea accident)	\$
	<input type="checkbox"/> ANY AUTO						BODILY INJURY (Per person)	\$
	<input type="checkbox"/> OWNED AUTOS ONLY						BODILY INJURY (Per accident)	\$
	<input type="checkbox"/> HIRED AUTOS ONLY						PROPERTY DAMAGE (Per accident)	\$
	<input type="checkbox"/> SCHEDULED AUTOS							\$
	<input type="checkbox"/> NON-OWNED AUTOS ONLY							\$
	UMBRELLA LIAB						EACH OCCURRENCE	\$
	<input type="checkbox"/> EXCESS LIAB						AGGREGATE	\$
	DED							\$
	RETENTION \$							\$
	WORKERS COMPENSATION AND EMPLOYERS' LIABILITY						PER STATUTE	OTH-ER
	ANY PROPRIETOR/PARTNER/EXECUTIVE OFFICER/MEMBER EXCLUDED? (Mandatory in NH)	Y / N		N / A			E.L. EACH ACCIDENT	\$
	If yes, describe under DESCRIPTION OF OPERATIONS below						E.L. DISEASE - EA EMPLOYEE	\$
							E.L. DISEASE - POLICY LIMIT	\$

DESCRIPTION OF OPERATIONS / LOCATIONS / VEHICLES (ACORD 101, Additional Remarks Schedule, may be attached if more space is required)

City of Spokane, its officers and employees are included as Additional Insureds under the General Liability per attached policy form.

General Liability policy shall be Primary and Non-Contributory with any other insurance in force for or which may be purchased by Additional Insured

CERTIFICATE HOLDER**CANCELLATION**

City of Spokane 808 W Spokane Falls Blvd Spokane, WA 99201	SHOULD ANY OF THE ABOVE DESCRIBED POLICIES BE CANCELLED BEFORE THE EXPIRATION DATE THEREOF, NOTICE WILL BE DELIVERED IN ACCORDANCE WITH THE POLICY PROVISIONS.
	AUTHORIZED REPRESENTATIVE <i>Patricia A. Jony</i>

© 1988-2016 ACORD CORPORATION. All rights reserved.



ADDITIONAL REMARKS SCHEDULE

AGENCY Willis Towers Watson Northeast, Inc.		NAMED INSURED Quadiant, Inc. 478 Wheelers Farms Rd Milford, CT 06461	
POLICY NUMBER See Page 1		EFFECTIVE DATE: See Page 1	
CARRIER See Page 1	NAIC CODE See Page 1		

ADDITIONAL REMARKS

THIS ADDITIONAL REMARKS FORM IS A SCHEDULE TO ACORD FORM,
FORM NUMBER: 25 **FORM TITLE:** Certificate of Liability Insurance

Waiver of Subrogation applies under the General Liability per attached policy form.

THIS ENDORSEMENT CHANGES THE POLICY. PLEASE READ IT CAREFULLY.

ADDITIONAL INSURED – DESIGNATED PERSON OR ORGANIZATION

This endorsement modifies insurance provided under the following:

COMMERCIAL GENERAL LIABILITY COVERAGE PART

SCHEDULE

Name Of Additional Insured Person(s) Or Organization(s):

Any person or organization that you are required in a written contract or written agreement to include as an additional insured provided the "Bodily Injury" or "Property Damage" occurs subsequent to the execution of the written contact or written agreement.

Information required to complete this Schedule, if not shown above, will be shown in the Declarations.

A. Section II – Who Is An Insured is amended to include as an additional insured the person(s) or organization(s) shown in the Schedule, but only with respect to liability for "bodily injury", "property damage" or "personal and advertising injury" caused, in whole or in part, by your acts or omissions or the acts or omissions of those acting on your behalf:

1. In the performance of your ongoing operations; or
2. In connection with your premises owned by or rented to you.

However:

1. The insurance afforded to such additional insured only applies to the extent permitted by law; and
2. If coverage provided to the additional insured is required by a contract or agreement, the insurance afforded to such additional insured will not be broader than that which you are required by the contract or agreement to provide for such additional insured.

B. With respect to the insurance afforded to these additional insureds, the following is added to **Section III – Limits Of Insurance:**

If coverage provided to the additional insured is required by a contract or agreement, the most we will pay on behalf of the additional insured is the amount of insurance:

1. Required by the contract or agreement; or
2. Available under the applicable limits of insurance;

whichever is less.

This endorsement shall not increase the applicable limits of insurance.

THIS ENDORSEMENT CHANGES THE POLICY. PLEASE READ IT CAREFULLY.

ADDITIONAL INSURED – OWNERS, LESSEES OR CONTRACTORS – COMPLETED OPERATIONS

This endorsement modifies insurance provided under the following:

COMMERCIAL GENERAL LIABILITY COVERAGE PART
PRODUCTS/COMPLETED OPERATIONS LIABILITY COVERAGE PART

SCHEDULE

Name Of Additional Insured Person(s) Or Organization(s)	Location And Description Of Completed Operations
Any person or organization that you are required in a written contract or written agreement to include as an additional insured provided the "Bodily Injury" or "Property Damage" occurs subsequent to the execution of the written contact or written agreement.	As required by a written contract
Information required to complete this Schedule, if not shown above, will be shown in the Declarations.	

A. Section II – Who Is An Insured is amended to include as an additional insured the person(s) or organization(s) shown in the Schedule, but only with respect to liability for "bodily injury" or "property damage" caused, in whole or in part, by "your work" at the location designated and described in the Schedule of this endorsement performed for that additional insured and included in the "products-completed operations hazard".

However:

1. The insurance afforded to such additional insured only applies to the extent permitted by law; and
2. If coverage provided to the additional insured is required by a contract or agreement, the insurance afforded to such additional insured will not be broader than that which you are required by the contract or agreement to provide for such additional insured.

B. With respect to the insurance afforded to these additional insureds, the following is added to **Section III – Limits Of Insurance:**

If coverage provided to the additional insured is required by a contract or agreement, the most we will pay on behalf of the additional insured is the amount of insurance:

1. Required by the contract or agreement; or
 2. Available under the applicable limits of insurance;
- whichever is less.

This endorsement shall not increase the applicable limits of insurance.

ENDORSEMENT # 004

This endorsement, effective 12:01 a.m., April 01, 2024 forms a part of Policy No. US00108254LI24A issued to Quadient, Inc. by XL Insurance America, Inc.

THIS ENDORSEMENT CHANGES THE POLICY. PLEASE READ IT CAREFULLY.

PRIMARY INSURANCE CLAUSE ENDORSEMENT

This endorsement modifies insurance provided under the following:

COMMERCIAL GENERAL LIABILITY COVERAGE PART
PRODUCTS/COMPLETED OPERATIONS COVERAGE PART

It is agreed that to the extent that insurance is afforded to any Additional Insured under this policy, this insurance shall apply as primary and not contributing with any insurance carried by such Additional Insured, as required by written contract.

All other terms and conditions of this policy remain unchanged.

THIS ENDORSEMENT CHANGES THE POLICY. PLEASE READ IT CAREFULLY.

WAIVER OF TRANSFER OF RIGHTS OF RECOVERY AGAINST OTHERS TO US (WAIVER OF SUBROGATION)

This endorsement modifies insurance provided under the following:

- COMMERCIAL GENERAL LIABILITY COVERAGE PART
- ELECTRONIC DATA LIABILITY COVERAGE PART
- LIQUOR LIABILITY COVERAGE PART
- POLLUTION LIABILITY COVERAGE PART DESIGNATED SITES
- POLLUTION LIABILITY LIMITED COVERAGE PART DESIGNATED SITES
- PRODUCTS/COMPLETED OPERATIONS LIABILITY COVERAGE PART
- RAILROAD PROTECTIVE LIABILITY COVERAGE PART
- UNDERGROUND STORAGE TANK POLICY DESIGNATED TANKS

SCHEDULE

<p>Name Of Person(s) Or Organization(s):</p> <p>Any person or organization that your are required in a written contract or written agreement to waive any right of recovery we may have against the person or organization, provided the "Bodily Injury" or "Property Damage" occurs subsequent to the execution of the written contract or written agreement.</p>
<p>Information required to complete this Schedule, if not shown above, will be shown in the Declarations.</p>

The following is added to Paragraph **8. Transfer Of Rights Of Recovery Against Others To Us** of **Section IV – Conditions:**

We waive any right of recovery against the person(s) or organization(s) shown in the Schedule above because of payments we make under this Coverage Part. Such waiver by us applies only to the extent that the insured has waived its right of recovery against such person(s) or organization(s) prior to loss. This endorsement applies only to the person(s) or organization(s) shown in the Schedule above.



CERTIFICATE OF LIABILITY INSURANCE

DATE (MM/DD/YYYY)

5/8/2024

THIS CERTIFICATE IS ISSUED AS A MATTER OF INFORMATION ONLY AND CONFERS NO RIGHTS UPON THE CERTIFICATE HOLDER. THIS CERTIFICATE DOES NOT AFFIRMATIVELY OR NEGATIVELY AMEND, EXTEND OR ALTER THE COVERAGE AFFORDED BY THE POLICIES BELOW. THIS CERTIFICATE OF INSURANCE DOES NOT CONSTITUTE A CONTRACT BETWEEN THE ISSUING INSURER(S), AUTHORIZED REPRESENTATIVE OR PRODUCER, AND THE CERTIFICATE HOLDER.

IMPORTANT: If the certificate holder is an **ADDITIONAL INSURED**, the policy(ies) must have **ADDITIONAL INSURED** provisions or be endorsed. If **SUBROGATION IS WAIVED**, subject to the terms and conditions of the policy, certain policies may require an endorsement. A statement on this certificate does not confer rights to the certificate holder in lieu of such endorsement(s).

PRODUCER Acrisure Partners West Coast Insurance Services, LLC 1950 W. Corporate Way #1 Anaheim CA 92801 License#: 6009644 NEOPUSA-01	CONTACT NAME: Certificate Department PHONE (A/C, No, Ext): 925-686-2860 FAX (A/C, No): 925-686-6118 E-MAIL ADDRESS: Certificates@pdins.com													
	<table border="1"> <thead> <tr> <th>INSURER(S) AFFORDING COVERAGE</th> <th>NAIC #</th> </tr> </thead> <tbody> <tr> <td>INSURER A : Liberty Mutual Fire Insurance Company</td> <td>23035</td> </tr> <tr> <td>INSURER B : Travelers Property Casualty Company of America</td> <td>25674</td> </tr> <tr> <td>INSURER C : LM Insurance Corporation</td> <td>33600</td> </tr> <tr> <td>INSURER D : Travelers Casualty and Surety Company of America</td> <td>31194</td> </tr> <tr> <td>INSURER E :</td> <td></td> </tr> <tr> <td>INSURER F :</td> <td></td> </tr> </tbody> </table>	INSURER(S) AFFORDING COVERAGE	NAIC #	INSURER A : Liberty Mutual Fire Insurance Company	23035	INSURER B : Travelers Property Casualty Company of America	25674	INSURER C : LM Insurance Corporation	33600	INSURER D : Travelers Casualty and Surety Company of America	31194	INSURER E :		INSURER F :
INSURER(S) AFFORDING COVERAGE	NAIC #													
INSURER A : Liberty Mutual Fire Insurance Company	23035													
INSURER B : Travelers Property Casualty Company of America	25674													
INSURER C : LM Insurance Corporation	33600													
INSURER D : Travelers Casualty and Surety Company of America	31194													
INSURER E :														
INSURER F :														
INSURED Quadient, Inc. 478 Wheelers Farms Road Milford CT 06461														

COVERAGES **CERTIFICATE NUMBER:** 1334034657 **REVISION NUMBER:**

THIS IS TO CERTIFY THAT THE POLICIES OF INSURANCE LISTED BELOW HAVE BEEN ISSUED TO THE INSURED NAMED ABOVE FOR THE POLICY PERIOD INDICATED. NOTWITHSTANDING ANY REQUIREMENT, TERM OR CONDITION OF ANY CONTRACT OR OTHER DOCUMENT WITH RESPECT TO WHICH THIS CERTIFICATE MAY BE ISSUED OR MAY PERTAIN, THE INSURANCE AFFORDED BY THE POLICIES DESCRIBED HEREIN IS SUBJECT TO ALL THE TERMS, EXCLUSIONS AND CONDITIONS OF SUCH POLICIES. LIMITS SHOWN MAY HAVE BEEN REDUCED BY PAID CLAIMS.

INSR LTR	TYPE OF INSURANCE	ADDL INSD	SUBR WVD	POLICY NUMBER	POLICY EFF (MM/DD/YYYY)	POLICY EXP (MM/DD/YYYY)	LIMITS
	COMMERCIAL GENERAL LIABILITY <input type="checkbox"/> CLAIMS-MADE <input type="checkbox"/> OCCUR GEN'L AGGREGATE LIMIT APPLIES PER: <input type="checkbox"/> POLICY <input type="checkbox"/> PRO-JECT <input type="checkbox"/> LOC <input type="checkbox"/> OTHER:						EACH OCCURRENCE \$ DAMAGE TO RENTED PREMISES (Ea occurrence) \$ MED EXP (Any one person) \$ PERSONAL & ADV INJURY \$ GENERAL AGGREGATE \$ PRODUCTS - COMP/OP AGG \$ \$
A	AUTOMOBILE LIABILITY <input checked="" type="checkbox"/> ANY AUTO <input type="checkbox"/> OWNED AUTOS ONLY <input type="checkbox"/> SCHEDULED AUTOS <input checked="" type="checkbox"/> HIRED AUTOS ONLY <input checked="" type="checkbox"/> NON-OWNED AUTOS ONLY			AS2661066867034	2/1/2024	2/1/2025	COMBINED SINGLE LIMIT (Ea accident) \$ 1,000,000 BODILY INJURY (Per person) \$ BODILY INJURY (Per accident) \$ PROPERTY DAMAGE (Per accident) \$ Comp/Coll Ded: \$25,000
B	UMBRELLA LIAB <input checked="" type="checkbox"/> OCCUR <input checked="" type="checkbox"/> EXCESS LIAB <input type="checkbox"/> CLAIMS-MADE DED <input checked="" type="checkbox"/> RETENTION \$ 0			EX7X448510	2/1/2024	2/1/2025	EACH OCCURRENCE \$ 5,000,000 AGGREGATE \$ 5,000,000 \$
C	WORKERS COMPENSATION AND EMPLOYERS' LIABILITY ANY PROPRIETOR/PARTNER/EXECUTIVE OFFICER/MEMBER EXCLUDED? (Mandatory in NH) If yes, describe under DESCRIPTION OF OPERATIONS below	Y/N N	N/A	WA566D066867024	2/1/2024	2/1/2025	<input checked="" type="checkbox"/> PER STATUTE <input type="checkbox"/> OTH-ER E.L. EACH ACCIDENT \$ 1,000,000 E.L. DISEASE - EA EMPLOYEE \$ 1,000,000 E.L. DISEASE - POLICY LIMIT \$ 1,000,000
D	Crime / Fidelity			105559991	2/1/2024	2/1/2025	Aggregate Deductible 1,000,000 50,000

DESCRIPTION OF OPERATIONS / LOCATIONS / VEHICLES (ACORD 101, Additional Remarks Schedule, may be attached if more space is required)
 As required by written contract, the following endorsements apply to the Certificate Holder and/or any other entity, named in this section: Auto Liability Additional Insured CA2048 10-13, Auto Liability Waiver of Subrogation CA0444 10-13, Auto Liability Primary Wording CA 04 49 11 16 & CA0001 10-13; Workers' Compensation Waiver of Subrogation WC000313 04-84

Errors & Omissions/Cyber - Landmark American Insurance Co. - LCY845247 - Limit per claim/occurrence/Agg: \$5,000,000 - Retention \$50,000
 Eff: 2/1/2024 - 2/1/2025

Errors & Omissions/Cyber - Excess - \$5M Excess of \$5M - Steadfast Insurance Company - EOC251041802 - Limit Occurrence: \$5,000,000
 See Attached...

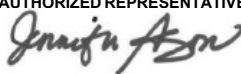
CERTIFICATE HOLDER City of Spokane 808 W Spokane Falls Blvd Spokane WA 99201	CANCELLATION SHOULD ANY OF THE ABOVE DESCRIBED POLICIES BE CANCELLED BEFORE THE EXPIRATION DATE THEREOF, NOTICE WILL BE DELIVERED IN ACCORDANCE WITH THE POLICY PROVISIONS. AUTHORIZED REPRESENTATIVE 
--	--

© 1988-2015 ACORD CORPORATION. All rights reserved.



ADDITIONAL REMARKS SCHEDULE

AGENCY Acrisure Partners West Coast Insurance Services, LLC		NAMED INSURED Quadient, Inc. 478 Wheelers Farms Road Milford CT 06461	
POLICY NUMBER		EFFECTIVE DATE:	
CARRIER	NAIC CODE	(Empty)	

ADDITIONAL REMARKS

THIS ADDITIONAL REMARKS FORM IS A SCHEDULE TO ACORD FORM,
FORM NUMBER: 25 FORM TITLE: CERTIFICATE OF LIABILITY INSURANCE

Eff: 2/1/2024 – 2/1/2025
 City of Spokane, its officers and employees

THIS ENDORSEMENT CHANGES THE POLICY. PLEASE READ IT CAREFULLY.

PRIMARY AND NONCONTRIBUTORY – OTHER INSURANCE CONDITION

This endorsement modifies insurance provided under the following:

AUTO DEALERS COVERAGE FORM
BUSINESS AUTO COVERAGE FORM
MOTOR CARRIER COVERAGE FORM

With respect to coverage provided by this endorsement, the provisions of the Coverage Form apply unless modified by the endorsement.

A. The following is added to the **Other Insurance Condition** in the Business Auto Coverage Form and the **Other Insurance – Primary And Excess Insurance Provisions** in the Motor Carrier Coverage Form and supersedes any provision to the contrary:

This Coverage Form's Covered Autos Liability Coverage is primary to and will not seek contribution from any other insurance available to an "insured" under your policy provided that:

1. Such "insured" is a Named Insured under such other insurance; and
2. You have agreed in writing in a contract or agreement that this insurance would be primary and would not seek contribution from any other insurance available to such "insured".

B. The following is added to the **Other Insurance Condition** in the Auto Dealers Coverage Form and supersedes any provision to the contrary:

This Coverage Form's Covered Autos Liability Coverage and General Liability Coverages are primary to and will not seek contribution from any other insurance available to an "insured" under your policy provided that:

1. Such "insured" is a Named Insured under such other insurance; and
2. You have agreed in writing in a contract or agreement that this insurance would be primary and would not seek contribution from any other insurance available to such "insured".

THIS ENDORSEMENT CHANGES THE POLICY. PLEASE READ IT CAREFULLY.

DESIGNATED INSURED FOR COVERED AUTOS LIABILITY COVERAGE

This endorsement modifies insurance provided under the following:

- AUTO DEALERS COVERAGE FORM
- BUSINESS AUTO COVERAGE FORM
- MOTOR CARRIER COVERAGE FORM

With respect to coverage provided by this endorsement, the provisions of the Coverage Form apply unless modified by the endorsement.

This endorsement identifies person(s) or organization(s) who are "insureds" for Covered Autos Liability Coverage under the Who Is An Insured provision of the Coverage Form. This endorsement does not alter coverage provided in the Coverage Form.

SCHEDULE

Name Of Person(s) Or Organization(s):

Any person or organization whom you have agreed in writing to add as an additional insured, but only to coverage and minimum limits of insurance required by the written agreement, and in no event to exceed either the scope of coverage or the limits of insurance provided in this policy.

Information required to complete this Schedule, if not shown above, will be shown in the Declarations.

Each person or organization shown in the Schedule is an "insured" for Covered Autos Liability Coverage, but only to the extent that person or organization qualifies as an "insured" under the Who Is An Insured provision contained in Paragraph A.1. of Section II - Covered Autos Liability Coverage in the Business Auto and Motor Carrier Coverage Forms and Paragraph D.2. of Section I - Covered Autos Coverages of the Auto Dealers Coverage Form.

THIS ENDORSEMENT CHANGES THE POLICY. PLEASE READ IT CAREFULLY.

BUSINESS AUTO COVERAGE FORM

Various provisions in this policy restrict coverage. Read the entire policy carefully to determine rights, duties and what is and is not covered.

Throughout this policy the words "you" and "your" refer to the Named Insured shown in the Declarations. The words "we", "us" and "our" refer to the company providing this insurance.

Other words and phrases that appear in quotation marks have special meaning. Refer to Section V – Definitions.

SECTION I – COVERED AUTOS

Item Two of the Declarations shows the "autos" that are covered "autos" for each of your coverages. The following numerical symbols describe the "autos" that may be covered "autos". The symbols entered next to a coverage on the Declarations designate the only "autos" that are covered "autos".

A. Description Of Covered Auto Designation Symbols

Symbol	Description Of Covered Auto Designation Symbols	
1	Any "Auto"	
2	Owned "Autos" Only	Only those "autos" you own (and for Covered Autos Liability Coverage any "trailers" you don't own while attached to power units you own). This includes those "autos" you acquire ownership of after the policy begins.
3	Owned Private Passenger "Autos" Only	Only the private passenger "autos" you own. This includes those private passenger "autos" you acquire ownership of after the policy begins.
4	Owned "Autos" Other Than Private Passenger "Autos" Only	Only those "autos" you own that are not of the private passenger type (and for Covered Autos Liability Coverage any "trailers" you don't own while attached to power units you own). This includes those "autos" not of the private passenger type you acquire ownership of after the policy begins.
5	Owned "Autos" Subject To No-fault	Only those "autos" you own that are required to have no-fault benefits in the state where they are licensed or principally garaged. This includes those "autos" you acquire ownership of after the policy begins provided they are required to have no-fault benefits in the state where they are licensed or principally garaged.
6	Owned "Autos" Subject To A Compulsory Uninsured Motorists Law	Only those "autos" you own that because of the law in the state where they are licensed or principally garaged are required to have and cannot reject Uninsured Motorists Coverage. This includes those "autos" you acquire ownership of after the policy begins provided they are subject to the same state uninsured motorists requirement.
7	Specifically Described "Autos"	Only those "autos" described in Item Three of the Declarations for which a premium charge is shown (and for Covered Autos Liability Coverage any "trailers" you don't own while attached to any power unit described in Item Three).
8	Hired "Autos" Only	Only those "autos" you lease, hire, rent or borrow. This does not include any "auto" you lease, hire, rent or borrow from any of your "employees", partners (if you are a partnership), members (if you are a limited liability company) or members of their households.
9	Non-owned "Autos" Only	Only those "autos" you do not own, lease, hire, rent or borrow that are used in connection with your business. This includes "autos" owned by your "employees", partners (if you are a partnership), members (if you are a limited liability company) or members of their households but only while used in your business or your personal affairs.

COMMERCIAL AUTO

19	Mobile Equipment Subject To Compulsory Or Financial Responsibility Or Other Motor Vehicle Insurance Law Only	Only those "autos" that are land vehicles and that would qualify under the definition of "mobile equipment" under this policy if they were not subject to a compulsory or financial responsibility law or other motor vehicle insurance law where they are licensed or principally garaged.
-----------	--	---

B. Owned Autos You Acquire After The Policy Begins

1. If Symbols **1, 2, 3, 4, 5, 6** or **19** are entered next to a coverage in Item Two of the Declarations, then you have coverage for "autos" that you acquire of the type described for the remainder of the policy period.
2. But, if Symbol **7** is entered next to a coverage in Item Two of the Declarations, an "auto" you acquire will be a covered "auto" for that coverage only if:
 - a. We already cover all "autos" that you own for that coverage or it replaces an "auto" you previously owned that had that coverage; and
 - b. You tell us within 30 days after you acquire it that you want us to cover it for that coverage.

C. Certain Trailers, Mobile Equipment And Temporary Substitute Autos

If Covered Autos Liability Coverage is provided by this Coverage Form, the following types of vehicles are also covered "autos" for Covered Autos Liability Coverage:

1. "Trailers" with a load capacity of 2,000 pounds or less designed primarily for travel on public roads.
2. "Mobile equipment" while being carried or towed by a covered "auto".
3. Any "auto" you do not own while used with the permission of its owner as a temporary substitute for a covered "auto" you own that is out of service because of its:
 - a. Breakdown;
 - b. Repair;
 - c. Servicing;
 - d. "Loss"; or
 - e. Destruction.

SECTION II – COVERED AUTOS LIABILITY COVERAGE

A. Coverage

We will pay all sums an "insured" legally must pay as damages because of "bodily injury" or "property damage" to which this insurance applies, caused by an "accident" and resulting from the ownership, maintenance or use of a covered "auto".

We will also pay all sums an "insured" legally must pay as a "covered pollution cost or expense" to which this insurance applies, caused by an "accident" and resulting from the ownership, maintenance or use of covered "autos". However, we will only pay for the "covered pollution cost or expense" if there is either "bodily injury" or "property damage" to which this insurance applies that is caused by the same "accident".

We have the right and duty to defend any "insured" against a "suit" asking for such damages or a "covered pollution cost or expense". However, we have no duty to defend any "insured" against a "suit" seeking damages for "bodily injury" or "property damage" or a "covered pollution cost or expense" to which this insurance does not apply. We may investigate and settle any claim or "suit" as we consider appropriate. Our duty to defend or settle ends when the Covered Autos Liability Coverage Limit of Insurance has been exhausted by payment of judgments or settlements.

1. Who Is An Insured

The following are "insureds":

- a. You for any covered "auto".
- b. Anyone else while using with your permission a covered "auto" you own, hire or borrow except:
 - (1) The owner or anyone else from whom you hire or borrow a covered "auto".

This exception does not apply if the covered "auto" is a "trailer" connected to a covered "auto" you own.

- (2) Your "employee" if the covered "auto" is owned by that "employee" or a member of his or her household.
 - (3) Someone using a covered "auto" while he or she is working in a business of selling, servicing, repairing, parking or storing "autos" unless that business is yours.
 - (4) Anyone other than your "employees", partners (if you are a partnership), members (if you are a limited liability company) or a lessee or borrower or any of their "employees", while moving property to or from a covered "auto".
 - (5) A partner (if you are a partnership) or a member (if you are a limited liability company) for a covered "auto" owned by him or her or a member of his or her household.
- c. Anyone liable for the conduct of an "insured" described above but only to the extent of that liability.

2. Coverage Extensions

a. Supplementary Payments

We will pay for the "insured":

- (1) All expenses we incur.
- (2) Up to \$2,000 for cost of bail bonds (including bonds for related traffic law violations) required because of an "accident" we cover. We do not have to furnish these bonds.
- (3) The cost of bonds to release attachments in any "suit" against the "insured" we defend, but only for bond amounts within our Limit of Insurance.
- (4) All reasonable expenses incurred by the "insured" at our request, including actual loss of earnings up to \$250 a day because of time off from work.
- (5) All court costs taxed against the "insured" in any "suit" against the "insured" we defend. However, these payments do not include attorneys' fees or attorneys' expenses taxed against the "insured".
- (6) All interest on the full amount of any judgment that accrues after entry of the judgment in any "suit" against the "insured" we defend, but our duty to

pay interest ends when we have paid, offered to pay or deposited in court the part of the judgment that is within our Limit of Insurance.

These payments will not reduce the Limit of Insurance.

b. Out-of-state Coverage Extensions

While a covered "auto" is away from the state where it is licensed, we will:

- (1) Increase the Limit of Insurance for Covered Autos Liability Coverage to meet the limits specified by a compulsory or financial responsibility law of the jurisdiction where the covered "auto" is being used. This extension does not apply to the limit or limits specified by any law governing motor carriers of passengers or property.
- (2) Provide the minimum amounts and types of other coverages, such as no-fault, required of out-of-state vehicles by the jurisdiction where the covered "auto" is being used.

We will not pay anyone more than once for the same elements of loss because of these extensions.

B. Exclusions

This insurance does not apply to any of the following:

1. Expected Or Intended Injury

"Bodily injury" or "property damage" expected or intended from the standpoint of the "insured".

2. Contractual

Liability assumed under any contract or agreement.

But this exclusion does not apply to liability for damages:

- a. Assumed in a contract or agreement that is an "insured contract", provided the "bodily injury" or "property damage" occurs subsequent to the execution of the contract or agreement; or
- b. That the "insured" would have in the absence of the contract or agreement.

3. Workers' Compensation

Any obligation for which the "insured" or the "insured's" insurer may be held liable under any workers' compensation, disability benefits

COMMERCIAL AUTO

or unemployment compensation law or any similar law.

4. Employee Indemnification And Employer's Liability

"Bodily injury" to:

- a. An "employee" of the "insured" arising out of and in the course of:
 - (1) Employment by the "insured"; or
 - (2) Performing the duties related to the conduct of the "insured's" business; or
- b. The spouse, child, parent, brother or sister of that "employee" as a consequence of Paragraph a. above.

This exclusion applies:

- (1) Whether the "insured" may be liable as an employer or in any other capacity; and
- (2) To any obligation to share damages with or repay someone else who must pay damages because of the injury.

But this exclusion does not apply to "bodily injury" to domestic "employees" not entitled to workers' compensation benefits or to liability assumed by the "insured" under an "insured contract". For the purposes of the Coverage Form, a domestic "employee" is a person engaged in household or domestic work performed principally in connection with a residence premises.

5. Fellow Employee

"Bodily injury" to:

- a. Any fellow "employee" of the "insured" arising out of and in the course of the fellow "employee's" employment or while performing duties related to the conduct of your business; or
- b. The spouse, child, parent, brother or sister of that fellow "employee" as a consequence of Paragraph a. above.

6. Care, Custody Or Control

"Property damage" to or "covered pollution cost or expense" involving property owned or transported by the "insured" or in the "insured's" care, custody or control. But this exclusion does not apply to liability assumed under a sidetrack agreement.

7. Handling Of Property

"Bodily injury" or "property damage" resulting from the handling of property:

- a. Before it is moved from the place where it is accepted by the "insured" for movement into or onto the covered "auto"; or
- b. After it is moved from the covered "auto" to the place where it is finally delivered by the "insured".

8. Movement Of Property By Mechanical Device

"Bodily injury" or "property damage" resulting from the movement of property by a mechanical device (other than a hand truck) unless the device is attached to the covered "auto".

9. Operations

"Bodily injury" or "property damage" arising out of the operation of:

- a. Any equipment listed in Paragraphs 6.b. and 6.c. of the definition of "mobile equipment"; or
- b. Machinery or equipment that is on, attached to or part of a land vehicle that would qualify under the definition of "mobile equipment" if it were not subject to a compulsory or financial responsibility law or other motor vehicle insurance law where it is licensed or principally garaged.

10. Completed Operations

"Bodily injury" or "property damage" arising out of your work after that work has been completed or abandoned.

In this exclusion, your work means:

- a. Work or operations performed by you or on your behalf; and
- b. Materials, parts or equipment furnished in connection with such work or operations.

Your work includes warranties or representations made at any time with respect to the fitness, quality, durability or performance of any of the items included in Paragraph a. or b. above.

Your work will be deemed completed at the earliest of the following times:

- (1) When all of the work called for in your contract has been completed;
- (2) When all of the work to be done at the site has been completed if your

contract calls for work at more than one site; or

- (3) When that part of the work done at a job site has been put to its intended use by any person or organization other than another contractor or sub-contractor working on the same project.

Work that may need service, maintenance, correction, repair or replacement, but which is otherwise complete, will be treated as completed.

11. Pollution

"Bodily injury" or "property damage" arising out of the actual, alleged or threatened discharge, dispersal, seepage, migration, release or escape of "pollutants":

- a. That are, or that are contained in any property that is:
 - (1) Being transported or towed by, handled or handled for movement into, onto or from the covered "auto";
 - (2) Otherwise in the course of transit by or on behalf of the "insured"; or
 - (3) Being stored, disposed of, treated or processed in or upon the covered "auto";
- b. Before the "pollutants" or any property in which the "pollutants" are contained are moved from the place where they are accepted by the "insured" for movement into or onto the covered "auto"; or
- c. After the "pollutants" or any property in which the "pollutants" are contained are moved from the covered "auto" to the place where they are finally delivered, disposed of or abandoned by the "insured".

Paragraph a. above does not apply to fuels, lubricants, fluids, exhaust gases or other similar "pollutants" that are needed for or result from the normal electrical, hydraulic or mechanical functioning of the covered "auto" or its parts if:

- (1) The "pollutants" escape, seep, migrate or are discharged, dispersed or released directly from an "auto" part designed by its manufacturer to hold, store, receive or dispose of such "pollutants"; and

- (2) The "bodily injury", "property damage" or "covered pollution cost or expense" does not arise out of the operation of any equipment listed in Paragraphs 6.b. and 6.c. of the definition of "mobile equipment".

Paragraphs b. and c. above of this exclusion do not apply to "accidents" that occur away from premises owned by or rented to an "insured" with respect to "pollutants" not in or upon a covered "auto" if:

- (a) The "pollutants" or any property in which the "pollutants" are contained are upset, overturned or damaged as a result of the maintenance or use of a covered "auto"; and
- (b) The discharge, dispersal, seepage, migration, release or escape of the "pollutants" is caused directly by such upset, overturn or damage.

12. War

"Bodily injury" or "property damage" arising directly or indirectly out of:

- a. War, including undeclared or civil war;
- b. Warlike action by a military force, including action in hindering or defending against an actual or expected attack, by any government, sovereign or other authority using military personnel or other agents; or
- c. Insurrection, rebellion, revolution, usurped power or action taken by governmental authority in hindering or defending against any of these.

13. Racing

Covered "autos" while used in any professional or organized racing or demolition contest or stunting activity, or while practicing for such contest or activity. This insurance also does not apply while that covered "auto" is being prepared for such a contest or activity.

C. Limit Of Insurance

Regardless of the number of covered "autos", "insureds", premiums paid, claims made or vehicles involved in the "accident", the most we will pay for the total of all damages and "covered pollution cost or expense" combined resulting from any one "accident" is the Limit Of Insurance for Covered Autos Liability Coverage shown in the Declarations.

COMMERCIAL AUTO

All "bodily injury", "property damage" and "covered pollution cost or expense" resulting from continuous or repeated exposure to substantially the same conditions will be considered as resulting from one "accident".

No one will be entitled to receive duplicate payments for the same elements of "loss" under this Coverage Form and any Medical Payments Coverage endorsement, Uninsured Motorists Coverage endorsement or Underinsured Motorists Coverage endorsement attached to this Coverage Part.

SECTION III – PHYSICAL DAMAGE COVERAGE

A. Coverage

1. We will pay for "loss" to a covered "auto" or its equipment under:

a. Comprehensive Coverage

From any cause except:

- (1) The covered "auto's" collision with another object; or
- (2) The covered "auto's" overturn.

b. Specified Causes Of Loss Coverage

Caused by:

- (1) Fire, lightning or explosion;
- (2) Theft;
- (3) Windstorm, hail or earthquake;
- (4) Flood;
- (5) Mischief or vandalism; or
- (6) The sinking, burning, collision or derailment of any conveyance transporting the covered "auto".

c. Collision Coverage

Caused by:

- (1) The covered "auto's" collision with another object; or
- (2) The covered "auto's" overturn.

2. Towing

We will pay up to the limit shown in the Declarations for towing and labor costs incurred each time a covered "auto" of the private passenger type is disabled. However, the labor must be performed at the place of disablement.

3. Glass Breakage – Hitting A Bird Or Animal – Falling Objects Or Missiles

If you carry Comprehensive Coverage for the damaged covered "auto", we will pay for the following under Comprehensive Coverage:

- a. Glass breakage;
- b. "Loss" caused by hitting a bird or animal; and
- c. "Loss" caused by falling objects or missiles.

However, you have the option of having glass breakage caused by a covered "auto's" collision or overturn considered a "loss" under Collision Coverage.

4. Coverage Extensions

a. Transportation Expenses

We will pay up to \$20 per day, to a maximum of \$600, for temporary transportation expense incurred by you because of the total theft of a covered "auto" of the private passenger type. We will pay only for those covered "autos" for which you carry either Comprehensive or Specified Causes Of Loss Coverage. We will pay for temporary transportation expenses incurred during the period beginning 48 hours after the theft and ending, regardless of the policy's expiration, when the covered "auto" is returned to use or we pay for its "loss".

b. Loss Of Use Expenses

For Hired Auto Physical Damage, we will pay expenses for which an "insured" becomes legally responsible to pay for loss of use of a vehicle rented or hired without a driver under a written rental contract or agreement. We will pay for loss of use expenses if caused by:

- (1) Other than collision only if the Declarations indicates that Comprehensive Coverage is provided for any covered "auto";
- (2) Specified Causes Of Loss only if the Declarations indicates that Specified Causes Of Loss Coverage is provided for any covered "auto"; or
- (3) Collision only if the Declarations indicates that Collision Coverage is provided for any covered "auto".

However, the most we will pay for any expenses for loss of use is \$20 per day, to a maximum of \$600.

B. Exclusions

1. We will not pay for "loss" caused by or resulting from any of the following. Such "loss" is excluded regardless of any other cause or

event that contributes concurrently or in any sequence to the "loss".

a. Nuclear Hazard

- (1) The explosion of any weapon employing atomic fission or fusion; or
- (2) Nuclear reaction or radiation, or radioactive contamination, however caused.

b. War Or Military Action

- (1) War, including undeclared or civil war;
- (2) Warlike action by a military force, including action in hindering or defending against an actual or expected attack, by any government, sovereign or other authority using military personnel or other agents; or
- (3) Insurrection, rebellion, revolution, usurped power or action taken by governmental authority in hindering or defending against any of these.

2. We will not pay for "loss" to any covered "auto" while used in any professional or organized racing or demolition contest or stunt activity, or while practicing for such contest or activity. We will also not pay for "loss" to any covered "auto" while that covered "auto" is being prepared for such a contest or activity.

3. We will not pay for "loss" due and confined to:

- a. Wear and tear, freezing, mechanical or electrical breakdown.
- b. Blowouts, punctures or other road damage to tires.

This exclusion does not apply to such "loss" resulting from the total theft of a covered "auto".

4. We will not pay for "loss" to any of the following:

- a. Tapes, records, discs or other similar audio, visual or data electronic devices designed for use with audio, visual or data electronic equipment.
- b. Any device designed or used to detect speed-measuring equipment, such as radar or laser detectors, and any jamming apparatus intended to elude or disrupt speed-measuring equipment.
- c. Any electronic equipment, without regard to whether this equipment is permanently

installed, that reproduces, receives or transmits audio, visual or data signals.

d. Any accessories used with the electronic equipment described in Paragraph c. above.

5. Exclusions 4.c. and 4.d. do not apply to equipment designed to be operated solely by use of the power from the "auto's" electrical system that, at the time of "loss", is:

- a. Permanently installed in or upon the covered "auto";
- b. Removable from a housing unit which is permanently installed in or upon the covered "auto";
- c. An integral part of the same unit housing any electronic equipment described in Paragraphs a. and b. above; or
- d. Necessary for the normal operation of the covered "auto" or the monitoring of the covered "auto's" operating system.

6. We will not pay for "loss" to a covered "auto" due to "diminution in value".

C. Limits Of Insurance

1. The most we will pay for:

a. "Loss" to any one covered "auto" is the lesser of:

- (1) The actual cash value of the damaged or stolen property as of the time of the "loss"; or
- (2) The cost of repairing or replacing the damaged or stolen property with other property of like kind and quality.

b. All electronic equipment that reproduces, receives or transmits audio, visual or data signals in any one "loss" is \$1,000, if, at the time of "loss", such electronic equipment is:

- (1) Permanently installed in or upon the covered "auto" in a housing, opening or other location that is not normally used by the "auto" manufacturer for the installation of such equipment;
- (2) Removable from a permanently installed housing unit as described in Paragraph b.(1) above; or
- (3) An integral part of such equipment as described in Paragraphs b.(1) and b.(2) above.

COMMERCIAL AUTO

2. An adjustment for depreciation and physical condition will be made in determining actual cash value in the event of a total "loss".
3. If a repair or replacement results in better than like kind or quality, we will not pay for the amount of the betterment.

D. Deductible

For each covered "auto", our obligation to pay for, repair, return or replace damaged or stolen property will be reduced by the applicable deductible shown in the Declarations. Any Comprehensive Coverage deductible shown in the Declarations does not apply to "loss" caused by fire or lightning.

SECTION IV – BUSINESS AUTO CONDITIONS

The following conditions apply in addition to the Common Policy Conditions:

A. Loss Conditions

1. Appraisal For Physical Damage Loss

If you and we disagree on the amount of "loss", either may demand an appraisal of the "loss". In this event, each party will select a competent appraiser. The two appraisers will select a competent and impartial umpire. The appraisers will state separately the actual cash value and amount of "loss". If they fail to agree, they will submit their differences to the umpire. A decision agreed to by any two will be binding. Each party will:

- a. Pay its chosen appraiser; and
- b. Bear the other expenses of the appraisal and umpire equally.

If we submit to an appraisal, we will still retain our right to deny the claim.

2. Duties In The Event Of Accident, Claim, Suit Or Loss

We have no duty to provide coverage under this policy unless there has been full compliance with the following duties:

- a. In the event of "accident", claim, "suit" or "loss", you must give us or our authorized representative prompt notice of the "accident" or "loss". Include:
 - (1) How, when and where the "accident" or "loss" occurred;
 - (2) The "insured's" name and address; and
 - (3) To the extent possible, the names and addresses of any injured persons and witnesses.

- b. Additionally, you and any other involved "insured" must:

- (1) Assume no obligation, make no payment or incur no expense without our consent, except at the "insured's" own cost.
- (2) Immediately send us copies of any request, demand, order, notice, summons or legal paper received concerning the claim or "suit".
- (3) Cooperate with us in the investigation or settlement of the claim or defense against the "suit".
- (4) Authorize us to obtain medical records or other pertinent information.
- (5) Submit to examination, at our expense, by physicians of our choice, as often as we reasonably require.

- c. If there is "loss" to a covered "auto" or its equipment, you must also do the following:

- (1) Promptly notify the police if the covered "auto" or any of its equipment is stolen.
- (2) Take all reasonable steps to protect the covered "auto" from further damage. Also keep a record of your expenses for consideration in the settlement of the claim.
- (3) Permit us to inspect the covered "auto" and records proving the "loss" before its repair or disposition.
- (4) Agree to examinations under oath at our request and give us a signed statement of your answers.

3. Legal Action Against Us

No one may bring a legal action against us under this Coverage Form until:

- a. There has been full compliance with all the terms of this Coverage Form; and
- b. Under Covered Autos Liability Coverage, we agree in writing that the "insured" has an obligation to pay or until the amount of that obligation has finally been determined by judgment after trial. No one has the right under this policy to bring us into an action to determine the "insured's" liability.

4. Loss Payment – Physical Damage Coverages

At our option, we may:

- a. Pay for, repair or replace damaged or stolen property;
- b. Return the stolen property, at our expense. We will pay for any damage that results to the "auto" from the theft; or
- c. Take all or any part of the damaged or stolen property at an agreed or appraised value.

If we pay for the "loss", our payment will include the applicable sales tax for the damaged or stolen property.

5. Transfer Of Rights Of Recovery Against Others To Us

If any person or organization to or for whom we make payment under this Coverage Form has rights to recover damages from another, those rights are transferred to us. That person or organization must do everything necessary to secure our rights and must do nothing after "accident" or "loss" to impair them.

B. General Conditions

1. Bankruptcy

Bankruptcy or insolvency of the "insured" or the "insured's" estate will not relieve us of any obligations under this Coverage Form.

2. Concealment, Misrepresentation Or Fraud

This Coverage Form is void in any case of fraud by you at any time as it relates to this Coverage Form. It is also void if you or any other "insured", at any time, intentionally conceals or misrepresents a material fact concerning:

- a. This Coverage Form;
- b. The covered "auto";
- c. Your interest in the covered "auto"; or
- d. A claim under this Coverage Form.

3. Liberalization

If we revise this Coverage Form to provide more coverage without additional premium charge, your policy will automatically provide the additional coverage as of the day the revision is effective in your state.

4. No Benefit To Bailee – Physical Damage Coverages

We will not recognize any assignment or grant any coverage for the benefit of any per-

son or organization holding, storing or transporting property for a fee regardless of any other provision of this Coverage Form.

5. Other Insurance

a. For any covered "auto" you own, this Coverage Form provides primary insurance. For any covered "auto" you don't own, the insurance provided by this Coverage Form is excess over any other collectible insurance. However, while a covered "auto" which is a "trailer" is connected to another vehicle, the Covered Autos Liability Coverage this Coverage Form provides for the "trailer" is:

- (1) Excess while it is connected to a motor vehicle you do not own; or
- (2) Primary while it is connected to a covered "auto" you own.

b. For Hired Auto Physical Damage Coverage, any covered "auto" you lease, hire, rent or borrow is deemed to be a covered "auto" you own. However, any "auto" that is leased, hired, rented or borrowed with a driver is not a covered "auto".

c. Regardless of the provisions of Paragraph a. above, this Coverage Form's Covered Autos Liability Coverage is primary for any liability assumed under an "insured contract".

d. When this Coverage Form and any other Coverage Form or policy covers on the same basis, either excess or primary, we will pay only our share. Our share is the proportion that the Limit of Insurance of our Coverage Form bears to the total of the limits of all the Coverage Forms and policies covering on the same basis.

6. Premium Audit

a. The estimated premium for this Coverage Form is based on the exposures you told us you would have when this policy began. We will compute the final premium due when we determine your actual exposures. The estimated total premium will be credited against the final premium due and the first Named Insured will be billed for the balance, if any. The due date for the final premium or retrospective premium is the date shown as the due date on the bill. If the estimated total premium exceeds the final premium due, the first Named Insured will get a refund.

COMMERCIAL AUTO

- b. If this policy is issued for more than one year, the premium for this Coverage Form will be computed annually based on our rates or premiums in effect at the beginning of each year of the policy.

7. Policy Period, Coverage Territory

Under this Coverage Form, we cover "accidents" and "losses" occurring:

- a. During the policy period shown in the Declarations; and
- b. Within the coverage territory.

The coverage territory is:

- (1) The United States of America;
- (2) The territories and possessions of the United States of America;
- (3) Puerto Rico;
- (4) Canada; and
- (5) Anywhere in the world if a covered "auto" of the private passenger type is leased, hired, rented or borrowed without a driver for a period of 30 days or less,

provided that the "insured's" responsibility to pay damages is determined in a "suit" on the merits, in the United States of America, the territories and possessions of the United States of America, Puerto Rico or Canada, or in a settlement we agree to.

We also cover "loss" to, or "accidents" involving, a covered "auto" while being transported between any of these places.

8. Two Or More Coverage Forms Or Policies Issued By Us

If this Coverage Form and any other Coverage Form or policy issued to you by us or any company affiliated with us applies to the same "accident", the aggregate maximum Limit of Insurance under all the Coverage Forms or policies shall not exceed the highest applicable Limit of Insurance under any one Coverage Form or policy. This condition does not apply to any Coverage Form or policy issued by us or an affiliated company specifically to apply as excess insurance over this Coverage Form.

SECTION V – DEFINITIONS

- A. "Accident" includes continuous or repeated exposure to the same conditions resulting in "bodily injury" or "property damage".
- B. "Auto" means:

- 1. A land motor vehicle, "trailer" or semitrailer designed for travel on public roads; or
- 2. Any other land vehicle that is subject to a compulsory or financial responsibility law or other motor vehicle insurance law where it is licensed or principally garaged.

However, "auto" does not include "mobile equipment".

- C. "Bodily injury" means bodily injury, sickness or disease sustained by a person, including death resulting from any of these.
- D. "Covered pollution cost or expense" means any cost or expense arising out of:
 - 1. Any request, demand, order or statutory or regulatory requirement that any "insured" or others test for, monitor, clean up, remove, contain, treat, detoxify or neutralize, or in any way respond to, or assess the effects of, "pollutants"; or
 - 2. Any claim or "suit" by or on behalf of a governmental authority for damages because of testing for, monitoring, cleaning up, removing, containing, treating, detoxifying or neutralizing, or in any way responding to, or assessing the effects of, "pollutants".

"Covered pollution cost or expense" does not include any cost or expense arising out of the actual, alleged or threatened discharge, dispersal, seepage, migration, release or escape of "pollutants":

- a. That are, or that are contained in any property that is:
 - (1) Being transported or towed by, handled or handled for movement into, onto or from the covered "auto";
 - (2) Otherwise in the course of transit by or on behalf of the "insured"; or
 - (3) Being stored, disposed of, treated or processed in or upon the covered "auto";
- b. Before the "pollutants" or any property in which the "pollutants" are contained are moved from the place where they are accepted by the "insured" for movement into or onto the covered "auto"; or
- c. After the "pollutants" or any property in which the "pollutants" are contained are moved from the covered "auto" to the place where they are finally delivered, disposed of or abandoned by the "insured".

Paragraph **a.** above does not apply to fuels, lubricants, fluids, exhaust gases or other similar "pollutants" that are needed for or result from the normal electrical, hydraulic or mechanical functioning of the covered "auto" or its parts, if:

- (1) The "pollutants" escape, seep, migrate or are discharged, dispersed or released directly from an "auto" part designed by its manufacturer to hold, store, receive or dispose of such "pollutants"; and
- (2) The "bodily injury", "property damage" or "covered pollution cost or expense" does not arise out of the operation of any equipment listed in Paragraph **6.b.** or **6.c.** of the definition of "mobile equipment".

Paragraphs **b.** and **c.** above do not apply to "accidents" that occur away from premises owned by or rented to an "insured" with respect to "pollutants" not in or upon a covered "auto" if:

- (a) The "pollutants" or any property in which the "pollutants" are contained are upset, overturned or damaged as a result of the maintenance or use of a covered "auto"; and
- (b) The discharge, dispersal, seepage, migration, release or escape of the "pollutants" is caused directly by such upset, overturn or damage.

- E.** "Diminution in value" means the actual or perceived loss in market value or resale value which results from a direct and accidental "loss".
- F.** "Employee" includes a "leased worker". "Employee" does not include a "temporary worker".
- G.** "Insured" means any person or organization qualifying as an insured in the Who Is An Insured provision of the applicable coverage. Except with respect to the Limit of Insurance, the coverage afforded applies separately to each insured who is seeking coverage or against whom a claim or "suit" is brought.
- H.** "Insured contract" means:
 1. A lease of premises;
 2. A sidetrack agreement;
 3. Any easement or license agreement, except in connection with construction or demolition operations on or within 50 feet of a railroad;

4. An obligation, as required by ordinance, to indemnify a municipality, except in connection with work for a municipality;
5. That part of any other contract or agreement pertaining to your business (including an indemnification of a municipality in connection with work performed for a municipality) under which you assume the tort liability of another to pay for "bodily injury" or "property damage" to a third party or organization. Tort liability means a liability that would be imposed by law in the absence of any contract or agreement; or
6. That part of any contract or agreement entered into, as part of your business, pertaining to the rental or lease, by you or any of your "employees", of any "auto". However, such contract or agreement shall not be considered an "insured contract" to the extent that it obligates you or any of your "employees" to pay for "property damage" to any "auto" rented or leased by you or any of your "employees".

An "insured contract" does not include that part of any contract or agreement:

- a. That indemnifies a railroad for "bodily injury" or "property damage" arising out of construction or demolition operations, within 50 feet of any railroad property and affecting any railroad bridge or trestle, tracks, roadbeds, tunnel, underpass or crossing;
 - b. That pertains to the loan, lease or rental of an "auto" to you or any of your "employees", if the "auto" is loaned, leased or rented with a driver; or
 - c. That holds a person or organization engaged in the business of transporting property by "auto" for hire harmless for your use of a covered "auto" over a route or territory that person or organization is authorized to serve by public authority.
- I.** "Leased worker" means a person leased to you by a labor leasing firm under an agreement between you and the labor leasing firm to perform duties related to the conduct of your business. "Leased worker" does not include a "temporary worker".
 - J.** "Loss" means direct and accidental loss or damage.
 - K.** "Mobile equipment" means any of the following types of land vehicles, including any attached machinery or equipment:

COMMERCIAL AUTO

1. Bulldozers, farm machinery, forklifts and other vehicles designed for use principally off public roads;
 2. Vehicles maintained for use solely on or next to premises you own or rent;
 3. Vehicles that travel on crawler treads;
 4. Vehicles, whether self-propelled or not, maintained primarily to provide mobility to permanently mounted:
 - a. Power cranes, shovels, loaders, diggers or drills; or
 - b. Road construction or resurfacing equipment such as graders, scrapers or rollers;
 5. Vehicles not described in Paragraph 1., 2., 3. or 4. above that are not self-propelled and are maintained primarily to provide mobility to permanently attached equipment of the following types:
 - a. Air compressors, pumps and generators, including spraying, welding, building cleaning, geophysical exploration, lighting and well-servicing equipment; or
 - b. Cherry pickers and similar devices used to raise or lower workers; or
 6. Vehicles not described in Paragraph 1., 2., 3. or 4. above maintained primarily for purposes other than the transportation of persons or cargo. However, self-propelled vehicles with the following types of permanently attached equipment are not "mobile equipment" but will be considered "autos":
 - a. Equipment designed primarily for:
 - (1) Snow removal;
 - (2) Road maintenance, but not construction or resurfacing; or
 - (3) Street cleaning;
 - b. Cherry pickers and similar devices mounted on automobile or truck chassis and used to raise or lower workers; and
 - c. Air compressors, pumps and generators, including spraying, welding, building cleaning, geophysical exploration, lighting or well-servicing equipment.
- However, "mobile equipment" does not include land vehicles that are subject to a compulsory or financial responsibility law or other motor vehicle insurance law where it is licensed or principally garaged. Land vehicles subject to a compulsory or financial responsibility law or other motor vehicle insurance law are considered "autos".
- L. "Pollutants" means any solid, liquid, gaseous or thermal irritant or contaminant, including smoke, vapor, soot, fumes, acids, alkalis, chemicals and waste. Waste includes materials to be recycled, reconditioned or reclaimed.
 - M. "Property damage" means damage to or loss of use of tangible property.
 - N. "Suit" means a civil proceeding in which:
 1. Damages because of "bodily injury" or "property damage"; or
 2. A "covered pollution cost or expense";to which this insurance applies, are alleged.
"Suit" includes:
 - a. An arbitration proceeding in which such damages or "covered pollution costs or expenses" are claimed and to which the "insured" must submit or does submit with our consent; or
 - b. Any other alternative dispute resolution proceeding in which such damages or "covered pollution costs or expenses" are claimed and to which the insured submits with our consent.
 - O. "Temporary worker" means a person who is furnished to you to substitute for a permanent "employee" on leave or to meet seasonal or short-term workload conditions.
 - P. "Trailer" includes semitrailer.

THIS ENDORSEMENT CHANGES THE POLICY. PLEASE READ IT CAREFULLY.

WAIVER OF TRANSFER OF RIGHTS OF RECOVERY AGAINST OTHERS TO US (WAIVER OF SUBROGATION)

This endorsement modifies insurance provided under the following:

AUTO DEALERS COVERAGE FORM
BUSINESS AUTO COVERAGE FORM
MOTOR CARRIER COVERAGE FORM

With respect to coverage provided by this endorsement, the provisions of the Coverage Form apply unless modified by the endorsement.

SCHEDULE

Name(s) Of Person(s) Or Organization(s):

Any person or organization for whom you perform work under a written contract if the contract requires you to obtain this agreement from us, but only if the contract is executed prior to the injury or damage occurring.

Premium: \$ INCL

Information required to complete this Schedule, if not shown above, will be shown in the Declarations.

The **Transfer Of Rights Of Recovery Against Others To Us** condition does not apply to the person(s) or organization(s) shown in the Schedule, but only to the extent that subrogation is waived prior to the "accident" or the "loss" under a contract with that person or organization.

WAIVER OF OUR RIGHT TO RECOVER FROM OTHERS ENDORSEMENT

We have the right to recover our payments from anyone liable for an injury covered by this policy. We will not enforce our right against the person or organization named in the Schedule. (This agreement applies only to the extent that you perform work under a written contract that requires you to obtain this agreement from us.)

This agreement shall not operate directly or indirectly to benefit anyone not named in the Schedule.

Schedule

Where required by contract or written agreement prior to loss.

This endorsement is executed by the

Premium \$

Effective Date 2/1/2024

Expiration Date 2/1/2025

For attachment to Policy No. WA566D066867024



STATE OF WASHINGTON

BUSINESS LICENSE

Profit Corporation

QUADIENT, INC.
NEOPOST USA INC
478 WHEELERS FARMS RD
MILFORD CT 06461-9105

TAX REGISTRATION - ACTIVE

Issue Date: Mar 02, 2024

Unified Business ID #: 600230713

Business ID #: 001

Location: 0003

Expires: Mar 31, 2025

CITY/COUNTY ENDORSEMENTS:

- BELLINGHAM GENERAL BUSINESS #028495 - ACTIVE
- LACEY GENERAL BUSINESS - NON-RESIDENT #29531 - ACTIVE
- OLYMPIA GENERAL BUSINESS - NON-RESIDENT #33585 - ACTIVE
- SPOKANE GENERAL BUSINESS - NON-RESIDENT #T12011074BUS - ACTIVE
- BOTHELL GENERAL BUSINESS - NON-RESIDENT #7078 - ACTIVE

This document lists the registrations, endorsements, and licenses authorized for the business named above. By accepting this document, the licensee certifies the information on the application was complete, true, and accurate to the best of his or her knowledge, and that business will be conducted in compliance with all applicable Washington state, county, and city regulations.

John Ryser
Director, Department of Revenue

UBI: 600230713 001 0003

QUADIENT, INC.
NEOPOST USA INC
478 WHEELERS FARMS RD
MILFORD CT 06461-9105

STATE OF WASHINGTON

FOLD HERE

FOLD HERE

TAX REGISTRATION - ACTIVE
 BELLINGHAM GENERAL BUSINESS #028495 - ACTIVE
 LACEY GENERAL BUSINESS - NON-RESIDENT #29531 - ACTIVE
 OLYMPIA GENERAL BUSINESS - NON-RESIDENT #33585 - ACTIVE
 SPOKANE GENERAL BUSINESS - NON-RESIDENT #T12011074BUS - ACTIVE
 BOTHELL GENERAL BUSINESS - NON-RESIDENT #7078 - ACTIVE

Expires: Mar 31, 2025

John Ryser
Director, Department of Revenue

IMPORTANT!

PLEASE READ THE FOLLOWING INFORMATION CAREFULLY BEFORE POSTING THIS LICENSE

General Information

Post this Business License in a visible location at your place of business.

If you were issued a Business License previously, **destroy the old one and post this one in its place.**

Login to My DOR at dor.wa.gov if you need to make changes to your business name, location, mailing address, telephone number, or business ownership.

Telephone: 360-705-6741

Endorsements

All endorsements should be renewed by the expiration date that appears on the front of this license to avoid any late fees.

If there is no expiration date, the endorsements remain active as long as you continue required reporting. Tax Registration, Unemployment Insurance, and Industrial Insurance endorsements require you to submit periodic reports. Each agency will send you the necessary reporting forms and instructions.

For assistance or to request this document in an alternate format, visit <http://business.wa.gov/BLS> or call (360) 705-6741. Teletype (TTY) users may use the Washington Relay Service by calling 711.

BLS-700-107 (07/27/20)



Agenda Sheet for City Council:

Committee: PIES **Date:** 07/15/2024

Committee Agenda type: Consent

Date Rec'd 7/15/2024

Clerk's File # OPR 2021-0713

Cross Ref #

Project # 2018099

Council Meeting Date: 08/12/2024

Submitting Dept	INTEGRATED CAPITAL	Bid #	
------------------------	--------------------	--------------	--

Contact Name/Phone	NATE SULYA 625-6988	Requisition #	CR 26459
---------------------------	---------------------	----------------------	----------

Contact E-Mail	NSULYA@SPOKANECITY.ORG		
-----------------------	------------------------	--	--

Agenda Item Type	Contract Item		
-------------------------	---------------	--	--

Council Sponsor(s)	BWILKERSON JBINGLE KKLITZKE		
---------------------------	-----------------------------	--	--

Agenda Item Name	4250 - CONTRACT AMENDMENT WITH GSI WATER SOLUTIONS FOR WELL		
-------------------------	---	--	--

Agenda Wording

Contract Amendment with GSI Water Solutions, Inc. for the Well Electric New Well Field study and extending through December 31, 2025 - additional \$132,900.00. Total contract amount: \$875,150.00.

Summary (Background)

The 1920 era well station needs to be rebuilt and an earlier study recommended constructing deeper wells in two new buildings at the site. The purpose of the Well Electric New Well Study is to evaluate the Well Electric site for groundwater expansion. To date, monitoring wells have been drilled on both sites, and the project's next steps involve installation and pumping of test production wells, followed by analysis of the pumping test date and development of concept plans of wellfields.

Lease? NO Grant related? NO Public Works? NO

Fiscal Impact

Approved in Current Year Budget? YES

Total Cost	\$ 132,900.00
------------	---------------

Current Year Cost	\$
-------------------	----

Subsequent Year(s) Cost	\$
-------------------------	----

Narrative

Amount

Budget Account

Expense	\$ 132,900.00	# 4250 42300 94340 56501 15788
---------	---------------	--------------------------------

Select	\$	#
--------	----	---

Select	\$	#
--------	----	---

Select	\$	#
--------	----	---

	\$	#
--	----	---

	\$	#
--	----	---



Continuation of Wording, Summary, Approvals, and Distribution

Agenda Wording

Summary (Background)

Approvals

<u>Dept Head</u>	DAVIS, MARCIA
<u>Division Director</u>	FEIST, MARLENE
<u>Accounting Manager</u>	ALBIN-MOORE, ANGELA
<u>Legal</u>	HARRINGTON,
<u>For the Mayor</u>	PICCOLO, MIKE

Additional Approvals

<u>PURCHASING</u>	NECHANICKY, JASON

Distribution List

John Porcello jporcello@gsiws.com	eraea@spokanecity.org
icmaccounting@spokanecity.org	nsulya@spokanecity.org
mdavis@spokanecity.org	mpapich@spokanecity.org
kjanssen@gsiws.com	

Committee Agenda Sheet

Public Infrastructure, Environment & Sustainability Committee

Committee Date	7/15/2024
Submitting Department	ICM
Contact Name	Mark Papich
Contact Email & Phone	mpapich@spokanecity.org 509-625-6310
Council Sponsor(s)	CP Wilkerson, CM Bingle, CM Klitzke
Select Agenda Item Type	<input checked="" type="checkbox"/> Consent <input type="checkbox"/> Discussion Time Requested:
Agenda Item Name	Well Electric New Well Field Study Contract Amendment
Proposed Council Action	<input checked="" type="checkbox"/> Approval to proceed to Legislative Agenda <input type="checkbox"/> Information Only
Summary (Background)	GSI Water Solutions, Inc. was selected to complete the Well Electric New Well Field Study in October 2021. This 1920 era well station needs to be rebuilt and an earlier study recommended constructing deeper wells in 2 new buildings at the site. The purpose of the Well Electric New Well Study is to evaluate the Well Electric site for groundwater expansion. This contract amendment is both for a time extension and cost increase.
Fiscal Impact	<p>Approved in current year budget? <input checked="" type="checkbox"/> Yes <input type="checkbox"/> No <input type="checkbox"/> N/A</p> <p>Total Cost: <u>\$132,900 for the amendment, total project cost \$875,150</u></p> <p>Current year cost: Subsequent year(s) cost:</p> <p>Narrative: <u>Unanticipated costs and increased scope require amending the contract amount.</u></p> <p>Funding Source <input checked="" type="checkbox"/> One-time <input type="checkbox"/> Recurring <input type="checkbox"/> N/A</p> <p>Specify funding source: Reallocation</p> <p>Is this funding source sustainable for future years, months, etc? Click or tap here to enter text.</p> <p>Expense Occurrence <input checked="" type="checkbox"/> One-time <input type="checkbox"/> Recurring <input type="checkbox"/> N/A</p> <p>Other budget impacts: (revenue generating, match requirements, etc.) n/a</p>
Operations Impacts (If N/A, please give a brief description as to why)	<ul style="list-style-type: none"> What impacts would the proposal have on historically excluded communities? Public works services and projects are designed to serve all citizens and businesses. We strive to offer a consistent level of service to all, to distribute public investment throughout the community and to respond to gaps in services identified in various City plans. How will data be collected, analyzed, and reported concerning the effect of the program/policy by racial, ethnic, gender identity, national origin, income level, disability, sexual orientation, or other existing disparities? N/A

- How will data be collected regarding the effectiveness of this program, policy, or product to ensure it is the right solution?

Public Works follows the City's established procurement and public works bidding regulations and policies to bring items forward, and then uses contract management best practices to ensure desired outcomes and regulatory compliance.

- Describe how this proposal aligns with current City Policies, including the Comprehensive Plan, Sustainability Action Plan, Capital Improvement Program, Neighborhood Master Plans, Council Resolutions, and others?

This work is consistent with annual budget strategies to limit costs and approved projects in the 6-year CIP.

Council Subcommittee Review

- Please provide a summary of council subcommittee review. If not reviewed by a council subcommittee, please explain why not.

N/A



City of Spokane
CONTRACT AMENDMENT/EXTENSION
Title: **WELL ELECTRIC NEW
WELL FIELD STUDY**

This Contract Amendment/Extension is made and entered into by and between the **CITY OF SPOKANE** as ("City"), a Washington municipal corporation, and **GSI WATER SOLUTIONS, INC.**, whose address is 55 SW Yamhill Street, Suite 300, Portland, Oregon 97204 as ("Consultant"), individually hereafter referenced as a "party", and together as the "parties".

WHEREAS, the parties entered into a Contract wherein the Consultant agreed to perform a Well Electric New Well Field Study; and

WHEREAS, additional work and time to perform has been requested, and the Contract time for performance needs to be extended, thus the original Contract needs to be formally Amended and Extended by this written document; and

NOW, THEREFORE, in consideration of these terms, the parties mutually agree as follows:

1. CONTRACT DOCUMENTS.

The Contract, dated November 15, 2021 and November 19, 2021, any previous amendments, addendums and / or extensions / renewals thereto, are incorporated by reference into this document as though written in full and shall remain in full force and effect except as provided herein.

2. EFFECTIVE DATE.

This Contract Amendment/Extension shall become effective on July 1, 2024 and shall run through December 31, 2025.

3. AMENDMENT.

The original Agreement is hereby amended to allow for increased costs and time to complete the Project in accordance with the attached Contract Amendment No. 2 Request.

4. COMPENSATION.

The City shall pay an additional amount not to exceed **ONE HUNDRED THIRTY-TWO THOUSAND NINE HUNDRED AND NO/100 DOLLARS (\$132,900.00)**, plus applicable sales tax, for everything furnished and done under this Contract Amendment/Extension. This is the maximum amount to be paid under this Amendment/Extension, and shall not be exceeded without the prior written authorization of the City, memorialized with the same formality as the original Contract and this document.

IN WITNESS WHEREOF, in consideration of the terms, conditions and covenants contained, or attached and incorporated and made a part, the parties have executed this Contract Amendment/Extension by having legally-binding representatives affix their signatures below.

GSI WATER SOLUTIONS, INC.

CITY OF SPOKANE

By _____
Signature Date

By _____
Signature Date

Type or Print Name

Type or Print Name

Title

Title

Attest:

Approved as to form:

City Clerk

Assistant City Attorney

Attachments that are part of this Agreement:
Consultant's Contract Amendment No. 2 Request

24-119

TASK 8

Groundwater Development Evaluation of the Site Across the River from the Well Electric Well Station

- One deep exploration boring converted to a monitoring well at the planned location along the right-of-way west of the existing well station (i.e., south of the river)
- One deep exploration boring converted to a monitoring well at the parcel across the river
- One test well at either location (i.e., one or the other) based on findings from the two deep exploration boreholes and City preference
- One shallow monitoring well installed next to the test well
- Conduct a site visit
- Evaluate setbacks and identifying a target drilling/work area
- Develop conceptual well design(s)
- Evaluate water disposal options and identifying a preferred location
- Develop a work sequence between the north and south sites
- Develop additional technical specifications
- Conduct utility locates
- Provide additional construction management support and managing the drilling contractor
- Collect soil samples for sieve analyses
- Analyze grain-size distributions and developing screen design
- Collect groundwater quality samples
- Generate a boring log and as-built diagram
- Refine/update the groundwater model
- Conceptualize facility layout
- Reporting and Task management



Contract Amendment Request: Amendment No. 2

To: Mark Papich, City of Spokane Integrated Capital Management Department
Marcia Davis, City of Spokane Integrated Capital Management Department

From: Kenny Janssen, GSI Water Solutions, Inc.
John Porcello, GSI Water Solutions, Inc.

Date: June 21, 2024

RE: Well Electric New Well Field Study (Contract OPR 2021-0713)

Introduction

GSI Water Solutions, Inc. (GSI), and its teaming partners (Landau Associates and Consor North America, Inc.) are currently conducting a hydrogeologic investigation for the City of Spokane, Washington (City) at the City's Well Electric Well Station. The project was first contracted in October 2021 with a scope of work that was focused on the existing well station property on the south bank of the Spokane River, at Upriver Dam. In June 2022, the City approved a contract amendment (Amendment No. 1) to expand the study to a second City-owned parcel of land across from Well Electric on the north side of the river. To date, monitoring wells have been drilled on both sites, and the project's next steps involve installation and pumping of test production wells, followed by analyses of the pumping test data and development of concept plans for full development of wellfields on both properties.

This letter requests (1) an extension of time for the contract and (2) a budget increase of \$132,900 to cover unanticipated costs incurred to date and increases in projected costs for the project moving forward. Details regarding these two topics are presented below.

Contract Time Extension

The original project schedule was delayed after completion of the monitoring wells on both land parcels in order to allow microscopic particulate analysis (MPA) and other water quality sampling to occur before commencing the installation of one or two test production wells, and to inform decisions about whether to install a test production well on one or both of the City-owned properties. In a series of meetings held in late April and May, City staff informed us that the City wishes to proceed with test well installation and pumping activities on both properties. The drilling contractor is expected to begin that work this summer or early fall, and field work is expected to be completed in early 2025. Data analyses, documentation, and development of concept plans is expected to take approximately 6 months after completion of the field work. To provide the City with maximum flexibility in administering the contract, we recommend that the contract be extended to an end date of December 31, 2025. It is our hope that the project work will be largely completed by mid-2025. A revised schedule will be provided after drilling work has begun this summer/fall.

Budget Amendment

A budget increase of \$132,900 is requested to complete the project. This will raise the total authorized project budget to \$875,150, compared with the current budget of \$742,250 that was authorized by the City in June 2022 under Budget Amendment No. 1. The requested budget increase of \$132,900 consists of the following:

- Increased labor costs since development of the original proposal in 2021.
- \$18,500 of additional budget (in Task 7) to provide groundwater model visualizations, to support the City's work to produce a video about groundwater conditions and its well stations.
- Increased GSI labor costs and subconsultant costs (primarily by Landau Associates) incurred to date for additional work activities not in the original and amended work scopes and for greater-than-anticipated time requirements for conducting and managing in-scope activities. These include:
 - Longer-than-anticipated field oversight of drilling activities on the north parcel.
 - Installation of two monitoring wells, rather than one, on the north parcel.
 - Two rounds of MPA sampling in late 2023 (October and November), rather than one round.
 - PFAS sampling, which requires more rigorous sampling protocols (and thus time) than MPA sampling and general water quality sampling.
 - Additional laboratory coordination work, additional laboratory analytical costs, and additional data validation and tabulation efforts (for MPA, PFAS, and general water quality sample results).

Table 1 below provides a summary of the current and requested budgets for each task under this proposal. Table 2 shows the same information but with additional rows showing the allocation of costs between GSI and its two subconsultants (Landau Associates and Consor). As shown in these tables, costs originally allocated to Task 6 will cover out-of-scope work incurred to date and a portion of the costs necessary to complete the project, but additional funding (\$132,900) is needed in order to complete the project.

Table 1 – Budget Amendment Summary

Task	Description	Current Total Budget Under Amendment No. 1	Requested Budget Change Under Amendment No. 2	Requested Total Budget Under Amendment No. 2
1	Field Program Planning	\$56,100	+ \$300	\$56,400
2	Test Well Installation and Field Investigation	\$249,900	+ \$108,000	\$357,900
3	Data Analysis, Evaluation, and Recommendations	\$61,800	+ \$1,000	\$62,800
4	Wellfield, Pumping System, and Facility Conceptual Plans	\$55,200	+ \$2,700	\$57,900
5	Report	\$44,000	+ \$4,500	\$48,500
6	Transmission Main Analysis and River Crossing Feasibility Assessment	\$115,900	- \$115,900	\$0
7	Additional As-Needed Services	\$48,800	+ \$33,700	\$82,500
8	North Site Evaluation	\$110,550	+ \$98,600	\$209,150
TOTALS		\$742,250	\$132,900	\$875,150

Costs for subconsultant services provided to GSI by Landau and Consor include a 4 percent markup.

Table 2 – Budget No. 2 Amendment Details

Task	Description	Current Total Budget Under Amendment No. 1	Requested Budget Change Under Amendment No. 2	Requested Total Budget Under Amendment No. 2
1	Field Program Planning	\$56,100	+ \$300	\$56,400
	GSI Labor and Expenses	\$33,098	-\$2,234	\$30,864
	Landau Associates	\$18,678	+\$1,458	\$20,136
	Conсор	\$3,232	+\$2,168	\$5,400
	PQ Products	\$1,092	-\$1,092	\$0
2	Test Well Installation and Field Investigation	\$249,900	+ \$108,000	\$357,900
	GSI Labor and Expenses	\$127,932	+\$60,836	\$188,768
	Landau Associates	\$116,705	+\$48,152	\$164,857
	Conсор	\$4,275	\$0	\$4,275
	PQ Products	\$988	-\$988	\$0
3	Data Analysis, Evaluation, and Recommendations	\$61,800	+ \$1,000	\$62,800
	GSI Labor and Expenses	\$32,575	+\$1,832	\$34,407
	Landau Associates	\$24,087	-\$832	\$23,255
	Conсор	\$5,138	\$0	\$5,138
	PQ Products	\$0	\$0	\$0
4	Wellfield, Pumping System, and Facility Conceptual Plans	\$55,200	+ \$2,700	\$57,900
	GSI Labor and Expenses	\$15,233	+\$2,700	\$17,933
	Landau Associates	\$10,683	\$0	\$10,683
	Conсор	\$29,284	\$0	\$29,284
	PQ Products	\$0	\$0	\$0
5	Report	\$44,000	+ \$4,500	\$48,500
	GSI Labor and Expenses	\$22,305	+\$4,500	\$26,805
	Landau Associates	\$21,695	\$0	\$21,695
	Conсор	\$0	\$0	\$0
	PQ Products	\$0	\$0	\$0
6	Transmission Main Analysis and River Crossing Feasibility Assessment	\$115,900	- \$115,900	\$0
	GSI Labor and Expenses	\$3,500	-\$3,500	\$0
	Landau Associates	\$76,390	-\$76,390	\$0
	Conсор	\$36,010	-\$36,010	\$0
	PQ Products	\$0	\$0	\$0
7	Additional As-Needed Services	\$48,800	+ \$33,700	\$82,500
	GSI Labor and Expenses	\$20,110	+\$33,940	\$54,050
	Landau Associates	\$23,585	\$0	\$23,585
	Conсор	\$4,865	\$0	\$4,865
	PQ Products	\$240	-\$240	\$0
8	North Site Evaluation	\$110,550	+ \$98,600	\$209,150
	GSI Labor and Expenses	\$33,000	+\$21,260	\$54,260
	Landau Associates	\$60,250	+\$79,040	\$139,290
	Conсор	\$15,600	\$0	\$15,600
	PQ Products	\$1,700	-\$1,700	\$0
TOTALS		\$742,250	\$132,900	\$875,150
	GSI Labor and Expenses	\$287,753	+\$119,334	\$407,087
	Landau Associates	\$352,073	+\$51,428	\$403,501
	Conсор	\$98,404	-\$33,842	\$64,562
	PQ Products	\$4,020	-\$4,020	\$0

Costs for subconsultant services provided to GSI by Landau and Conсор include a 4 percent markup.

We value our partnership with the City and appreciate this opportunity to continue to do business with you. Please contact us if you have any questions regarding this contract amendment request.

Sincerely,
GSI Water Solutions, Inc.



Kenny Janssen, LG
Principal Hydrogeologist



John Porcello, LHG
Principal Groundwater Hydrologist



CERTIFICATE OF LIABILITY INSURANCE

DATE (MM/DD/YYYY)

6/26/2024

THIS CERTIFICATE IS ISSUED AS A MATTER OF INFORMATION ONLY AND CONFERS NO RIGHTS UPON THE CERTIFICATE HOLDER. THIS CERTIFICATE DOES NOT AFFIRMATIVELY OR NEGATIVELY AMEND, EXTEND OR ALTER THE COVERAGE AFFORDED BY THE POLICIES BELOW. THIS CERTIFICATE OF INSURANCE DOES NOT CONSTITUTE A CONTRACT BETWEEN THE ISSUING INSURER(S), AUTHORIZED REPRESENTATIVE OR PRODUCER, AND THE CERTIFICATE HOLDER.

IMPORTANT: If the certificate holder is an **ADDITIONAL INSURED**, the policy(ies) must have **ADDITIONAL INSURED** provisions or be endorsed. If **SUBROGATION IS WAIVED**, subject to the terms and conditions of the policy, certain policies may require an endorsement. A statement on this certificate does not confer rights to the certificate holder in lieu of such endorsement(s).

PRODUCER AssuredPartners Design Professionals Insurance Services, LLC 3697 Mt. Diablo Blvd Suite 230 Lafayette CA 94549 License#: 6003745 GROUSOL-03	CONTACT NAME: Mandy Guo PHONE (A/C. No. Ext): 510-272-1402 FAX (A/C. No): E-MAIL ADDRESS: DesignProCerts@AssuredPartners.com													
	<table border="1"> <thead> <tr> <th>INSURER(S) AFFORDING COVERAGE</th> <th>NAIC #</th> </tr> </thead> <tbody> <tr> <td>INSURER A: Hartford Accident and Indemnity Company</td> <td>22357</td> </tr> <tr> <td>INSURER B: Crum & Forster Specialty Insurance Company</td> <td>44520</td> </tr> <tr> <td>INSURER C:</td> <td></td> </tr> <tr> <td>INSURER D:</td> <td></td> </tr> <tr> <td>INSURER E:</td> <td></td> </tr> <tr> <td>INSURER F:</td> <td></td> </tr> </tbody> </table>	INSURER(S) AFFORDING COVERAGE	NAIC #	INSURER A: Hartford Accident and Indemnity Company	22357	INSURER B: Crum & Forster Specialty Insurance Company	44520	INSURER C:		INSURER D:		INSURER E:		INSURER F:
INSURER(S) AFFORDING COVERAGE	NAIC #													
INSURER A: Hartford Accident and Indemnity Company	22357													
INSURER B: Crum & Forster Specialty Insurance Company	44520													
INSURER C:														
INSURER D:														
INSURER E:														
INSURER F:														

COVERAGES **CERTIFICATE NUMBER:** 1955001757 **REVISION NUMBER:**

THIS IS TO CERTIFY THAT THE POLICIES OF INSURANCE LISTED BELOW HAVE BEEN ISSUED TO THE INSURED NAMED ABOVE FOR THE POLICY PERIOD INDICATED. NOTWITHSTANDING ANY REQUIREMENT, TERM OR CONDITION OF ANY CONTRACT OR OTHER DOCUMENT WITH RESPECT TO WHICH THIS CERTIFICATE MAY BE ISSUED OR MAY PERTAIN, THE INSURANCE AFFORDED BY THE POLICIES DESCRIBED HEREIN IS SUBJECT TO ALL THE TERMS, EXCLUSIONS AND CONDITIONS OF SUCH POLICIES. LIMITS SHOWN MAY HAVE BEEN REDUCED BY PAID CLAIMS.

INSR LTR	TYPE OF INSURANCE	ADDL INSD	SUBR WVD	POLICY NUMBER	POLICY EFF (MM/DD/YYYY)	POLICY EXP (MM/DD/YYYY)	LIMITS
B	<input checked="" type="checkbox"/> COMMERCIAL GENERAL LIABILITY <input type="checkbox"/> CLAIMS-MADE <input checked="" type="checkbox"/> OCCUR <input checked="" type="checkbox"/> WA Stop Gap <input checked="" type="checkbox"/> XCU Included GEN'L AGGREGATE LIMIT APPLIES PER: <input type="checkbox"/> POLICY <input checked="" type="checkbox"/> PRO-JECT <input type="checkbox"/> LOC OTHER:	Y	Y	EPK145683	11/1/2023	11/1/2024	EACH OCCURRENCE \$2,000,000 DAMAGE TO RENTED PREMISES (Ea occurrence) \$50,000 MED EXP (Any one person) \$5,000 PERSONAL & ADV INJURY \$2,000,000 GENERAL AGGREGATE \$2,000,000 PRODUCTS - COMP/OP AGG \$2,000,000 \$
A	<input checked="" type="checkbox"/> AUTOMOBILE LIABILITY <input checked="" type="checkbox"/> ANY AUTO <input type="checkbox"/> OWNED AUTOS ONLY <input type="checkbox"/> SCHEDULED AUTOS <input checked="" type="checkbox"/> HIRED AUTOS ONLY <input checked="" type="checkbox"/> NON-OWNED AUTOS ONLY	Y	Y	57UECVK6212	11/1/2023	11/1/2024	COMBINED SINGLE LIMIT (Ea accident) \$1,000,000 BODILY INJURY (Per person) \$ BODILY INJURY (Per accident) \$ PROPERTY DAMAGE (Per accident) \$ \$
	<input type="checkbox"/> UMBRELLA LIAB <input type="checkbox"/> OCCUR <input type="checkbox"/> EXCESS LIAB <input type="checkbox"/> CLAIMS-MADE DED RETENTION \$						EACH OCCURRENCE \$ AGGREGATE \$ \$
	<input type="checkbox"/> WORKERS COMPENSATION AND EMPLOYERS' LIABILITY ANY PROPRIETOR/PARTNER/EXECUTIVE OFFICER/MEMBER EXCLUDED? (Mandatory in NH) If yes, describe under DESCRIPTION OF OPERATIONS below	Y/N	N/A				<input type="checkbox"/> PER STATUTE <input type="checkbox"/> OTH-ER E.L. EACH ACCIDENT \$ E.L. DISEASE - EA EMPLOYEE \$ E.L. DISEASE - POLICY LIMIT \$
B	Professional & Contractors Pollution Liability	Y	Y	EPK145683	11/1/2023	11/1/2024	Per Claim \$1,000,000 Annual Aggregate \$2,000,000

DESCRIPTION OF OPERATIONS / LOCATIONS / VEHICLES (ACORD 101, Additional Remarks Schedule, may be attached if more space is required)
 GSI Project # & Name : 436.008 City of Spokane, Washington :Well Electric Wellfield
 City Clerk's No. 2021-0713
 Engineering Services Project No. 2018099
 Location : Spokane , Washington
 "Hydrogeological Investigations"

Certificate Holder and any other party as required per written contract or agreement is an additional insured as respects general liability or as endorsed to the applicable policy and attached to this certificate. Waiver or Subrogation, Primary and Non-contributory, and Severability of Interest coverage applies as endorsed to each applicable policy and attached to this certificate. Additional Insured status does not apply to the professional liability policy.

CERTIFICATE HOLDER **CANCELLATION 30 Day Notice of Cancellation**

City of Spokane, Washington Engineering Department Second Floor, City Hall 808 W. Spokane Falls Blvd. Spokane Wa 99201	SHOULD ANY OF THE ABOVE DESCRIBED POLICIES BE CANCELLED BEFORE THE EXPIRATION DATE THEREOF, NOTICE WILL BE DELIVERED IN ACCORDANCE WITH THE POLICY PROVISIONS. AUTHORIZED REPRESENTATIVE 
--	---

© 1988-2015 ACORD CORPORATION. All rights reserved.



THIS ENDORSEMENT CHANGES THE POLICY. PLEASE READ IT CAREFULLY.

GENERAL CHANGE ENDORSEMENT

Policy Change
Number 005

POLICY NUMBER EPK-145683	POLICY CHANGES EFFECTIVE 01/08/2024	COMPANY Crum and Forster Specialty Insurance Company
NAMED INSURED Groundwater Solutions, Inc.		
COVERAGE PARTS AFFECTED COMMERCIAL GENERAL LIABILITY COVERAGE PART		
CHANGES		
In consideration of the premium charged, it is hereby agreed upon the General Change Endorsement 002 has been deleted from the policy in its entirety and replaced with the following.		
ADDITIONAL INSURED – OWNERS, LESSEES OR CONTRACTORS – COMPLETED OPERATIONS		
SCHEDULE		
Name of Additional Person(s) or Organization(s): Blanket when specifically required in a written contract with the named insured.	Location And Description Of Completed Operations: Blanket when specifically required in a written contract with the named insured.	
Information required to complete this Schedule, if not shown above, will be shown in the Declarations.		
Section III – Who Is An Insured within the Common Provisions is amended to include as an additional insured the person(s) or organization(s) shown in the Schedule above, but only with respect to liability arising for “bodily injury” or “property damage” caused, in whole or in part, by “your work” at the location designated and described in the schedule of this endorsement performed for that additional insured and included in the “products-completed operations hazard”.		
ALL OTHER TERMS AND CONDITIONS OF THE POLICY REMAIN UNCHANGED.		

Authorized Representative Signature

THIS ENDORSEMENT CHANGES THE POLICY. PLEASE READ IT CAREFULLY.

ADDITIONAL INSURED – OWNERS, LESSEES OR CONTRACTORS – SCHEDULED PERSON OR ORGANIZATION

This endorsement modifies insurance provided under the following:

COMMERCIAL GENERAL LIABILITY COVERAGE PART

SCHEDULE

Name Of Additional Insured Person(s) Or Organization(s):	Location(s) of Covered Operations
Blanket when specifically required in a written contract with the named insured.	Blanket when specifically required in a written contract with the named insured.
Information required to complete this Schedule, if not shown above, will be shown in the Declarations.	

A. Section III – Who Is An Insured within the Common Provisions is amended to include as an additional insured the person(s) or organization(s) shown in the Schedule, but only with respect to liability for “bodily injury”, “property damage” or “personal and advertising injury” cause, in whole or in part, by:

1. Your acts or omissions; or
2. The acts or omissions of those acting on your behalf;
in the performance of your ongoing operations for the additional insured(s) at the location(s) designated above.

With respect to the insurance afforded to these additional insureds, the following additional exclusions apply:

This insurance does not apply to “bodily injury” or “property damage” occurring after:

3. All work, including materials, parts or equipment furnished in connection with such work, on the project (other than service, maintenance or repairs) to be performed by or on behalf of the additional insured(s) at the location of the covered operations has been completed; or
4. That portion of “your work” out of which the injury or damage arises has been put to its intended use by any person or organization other than another contractor or subcontractor engaged in performing operations for a principal as a part of the same project.

THIS ENDORSEMENT CHANGES THE POLICY. PLEASE READ IT CAREFULLY.

PRIMARY AND NON-CONTRIBUTORY – OTHER INSURANCE CONDITION

This endorsement modifies insurance provided under the following:

Section VI – Common Conditions paragraph 1. Other Insurance within the Common Provisions is amended by the addition of the following which supersedes any provision to the contrary:

d. Primary And Noncontributory Insurance

This insurance is primary to and will not seek contribution from any other insurance available to an additional insured under your policy provided that:

- (1) The additional insured is a named insured under this insurance and
- (2) You have agreed in writing in a contract or agreement that this insurance would be primary and would not seek contribution from any other insurance available to the additional insured.



THIS ENDORSEMENT CHANGES THE POLICY. PLEASE READ IT CAREFULLY.

GENERAL CHANGE ENDORSEMENT

Policy Change
Number 004

POLICY NUMBER EPK-145683	POLICY CHANGES EFFECTIVE 01/08/2024	COMPANY Crum and Forster Specialty Insurance Company
NAMED INSURED Groundwater Solutions, Inc.		
COVERAGE PARTS AFFECTED COMMERCIAL GENERAL LIABILITY COVERAGE PART		
CHANGES		
In consideration of the premium charged, it is hereby agreed upon the General Change Endorsement 001 has been deleted from the policy in its entirety and replaced with the following.		
AMENDED WAIVER OF TRANSFER OF RIGHTS OF RECOVERY AGAINST OTHERS TO US		
SCHEDULE		
Name of Person(s) or Organization(s)		
Blanket when specifically required in a written contract with the named insured.		
Information required to complete this Schedule, if not shown above, will be shown in the Declarations.		
SECTION VI – COMMON CONDITIONS, item 17. Transfer Of Rights of Recovery Against Others To Us within the Common Provisions is amended by the addition of the following:		
Solely as respects the person(s) or organization(s) indicated in the Schedule shown above, we waive any right of recovery we may have against the person(s) or organization(s) indicated in the Schedule shown above because of payments we make for “damages” arising out of your ongoing operations or “your work” performed under a written contract with that person(s) or organization(s) and included in the “products-completed operations hazard”.		
ALL OTHER TERMS AND CONDITIONS OF THE POLICY REMAIN UNCHANGED		

Authorized Representative Signature

THIS ENDORSEMENT CHANGES THE POLICY. PLEASE READ IT CAREFULLY.

COMMERCIAL AUTOMOBILE BROAD FORM ENDORSEMENT

This endorsement modifies insurance provided under the following:

BUSINESS AUTO COVERAGE FORM

To the extent that the provisions of this endorsement provide broader benefits to the "insured" than other provisions of the Coverage Form, the provisions of this endorsement apply.

1. BROAD FORM INSURED

A. Subsidiaries and Newly Acquired or Formed Organizations

The Named Insured shown in the Declarations is amended to include:

- (1) Any legal business entity other than a partnership or joint venture, formed as a subsidiary in which you have an ownership interest of more than 50% on the effective date of the Coverage Form. However, the Named Insured does not include any subsidiary that is an "insured" under any other automobile policy or would be an "insured" under such a policy but for its termination or the exhaustion of its Limit of Insurance.
- (2) Any organization that is acquired or formed by you and over which you maintain majority ownership. However, the Named Insured does not include any newly formed or acquired organization:
 - (a) That is a partnership or joint venture,
 - (b) That is an "insured" under any other policy,
 - (c) That has exhausted its Limit of Insurance under any other policy, or
 - (d) 180 days or more after its acquisition or formation by you, unless you have given us notice of the acquisition or formation.

Coverage does not apply to "bodily injury" or "property damage" that results from an "accident" that occurred before you formed or acquired the organization.

B. Employees as Insureds

Paragraph A.1. - WHO IS AN INSURED - of SECTION II - LIABILITY COVERAGE is amended to add:

- d. Any "employee" of yours while using a covered "auto" you don't own, hire or borrow in your business or your personal affairs.

C. Lessors as Insureds

Paragraph A.1. - WHO IS AN INSURED - of Section II - Liability Coverage is amended to add:

- e. The lessor of a covered "auto" while the "auto" is leased to you under a written agreement if:
 - (1) The agreement requires you to provide direct primary insurance for the lessor and
 - (2) The "auto" is leased without a driver.

Such a leased "auto" will be considered a covered "auto" you own and not a covered "auto" you hire.

D. Additional Insured if Required by Contract

- (1) Paragraph A.1. - WHO IS AN INSURED - of Section II - Liability Coverage is amended to add:
 - f. When you have agreed, in a written contract or written agreement, that a person or organization be added as an additional insured on your business auto policy, such person or organization is an "insured", but only to the extent such person or organization is liable for "bodily injury" or "property damage" caused by the conduct of an "insured" under paragraphs a. or b. of Who Is An Insured with regard to the ownership, maintenance or use of a covered "auto."

The insurance afforded to any such additional insured applies only if the "bodily injury" or "property damage" occurs:

- (1) During the policy period, and
- (2) Subsequent to the execution of such written contract, and
- (3) Prior to the expiration of the period of time that the written contract requires such insurance be provided to the additional insured.

(2) How Limits Apply

If you have agreed in a written contract or written agreement that another person or organization be added as an additional insured on your policy, the most we will pay on behalf of such additional insured is the lesser of:

- (a) The limits of insurance specified in the written contract or written agreement; or
- (b) The Limits of Insurance shown in the Declarations.

Such amount shall be a part of and not in addition to Limits of Insurance shown in the Declarations and described in this Section.

(3) Additional Insureds Other Insurance

If we cover a claim or "suit" under this Coverage Part that may also be covered by other insurance available to an additional insured, such additional insured must submit such claim or "suit" to the other insurer for defense and indemnity.

However, this provision does not apply to the extent that you have agreed in a written contract or written agreement that this insurance is primary and non-contributory with the additional insured's own insurance.

(4) Duties in The Event Of Accident, Claim, Suit or Loss

If you have agreed in a written contract or written agreement that another person or organization be added as an additional insured on your policy, the additional insured shall be required to comply with the provisions in LOSS CONDITIONS 2. - DUTIES IN THE EVENT OF ACCIDENT, CLAIM, SUIT OR LOSS – OF SECTION IV – BUSINESS AUTO CONDITIONS, in the same manner as the Named Insured.

E. Primary and Non-Contributory if Required by Contract

Only with respect to insurance provided to an additional insured in 1.D. - Additional Insured If Required by Contract, the following provisions apply:

(3) Primary Insurance When Required By Contract

This insurance is primary if you have agreed in a written contract or written agreement that this insurance be primary. If other insurance is also primary, we will share with all that other insurance by the method described in Other Insurance 5.d.

(4) Primary And Non-Contributory To Other Insurance When Required By Contract

If you have agreed in a written contract or written agreement that this insurance is primary and non-contributory with the additional insured's own insurance, this insurance is primary and we will not seek contribution from that other insurance.

Paragraphs (3) and (4) do not apply to other insurance to which the additional insured has been added as an additional insured.

When this insurance is excess, we will have no duty to defend the insured against any "suit" if any other insurer has a duty to defend the insured against that "suit". If no other insurer defends, we will undertake to do so, but we will be entitled to the insured's rights against all those other insurers.

When this insurance is excess over other insurance, we will pay only our share of the amount of the loss, if any, that exceeds the sum of:

- (1) The total amount that all such other insurance would pay for the loss in the absence of this insurance; and
- (2) The total of all deductible and self-insured amounts under all that other insurance.

We will share the remaining loss, if any, by the method described in Other Insurance 5.d.

2. AUTOS RENTED BY EMPLOYEES

Any "auto" hired or rented by your "employee" on your behalf and at your direction will be considered an "auto" you hire.

The OTHER INSURANCE Condition is amended by adding the following:

If an "employee's" personal insurance also applies on an excess basis to a covered "auto" hired or rented by your "employee" on your behalf and at your direction, this insurance will be primary to the "employee's" personal insurance.

3. AMENDED FELLOW EMPLOYEE EXCLUSION

EXCLUSION 5. - FELLOW EMPLOYEE - of SECTION II - LIABILITY COVERAGE does not apply if you have workers' compensation insurance in-force covering all of your "employees".

Coverage is excess over any other collectible insurance.

4. HIRED AUTO PHYSICAL DAMAGE COVERAGE

If hired "autos" are covered "autos" for Liability Coverage and if Comprehensive, Specified Causes of Loss, or Collision coverages are provided under this Coverage Form for any "auto" you own, then the Physical Damage Coverages provided are extended to "autos" you hire or borrow, subject to the following limit.

The most we will pay for "loss" to any hired "auto" is:

- (1) \$100,000;
- (2) The actual cash value of the damaged or stolen property at the time of the "loss"; or
- (3) The cost of repairing or replacing the damaged or stolen property,

whichever is smallest, minus a deductible. The deductible will be equal to the largest deductible applicable to any owned "auto" for that coverage. No deductible applies to "loss" caused by fire or lightning. Hired Auto Physical Damage coverage is excess over any other collectible insurance. Subject to the above limit, deductible and excess provisions, we will provide coverage equal to the broadest coverage applicable to any covered "auto" you own.

We will also cover loss of use of the hired "auto" if it results from an "accident", you are legally liable and the lessor incurs an actual financial loss, subject to a maximum of \$1000 per "accident".

This extension of coverage does not apply to any "auto" you hire or borrow from any of your "employees", partners (if you are a partnership), members (if you are a limited liability company), or members of their households.

5. PHYSICAL DAMAGE - ADDITIONAL TEMPORARY TRANSPORTATION EXPENSE COVERAGE

Paragraph A.4.a. of SECTION III - PHYSICAL DAMAGE COVERAGE is amended to provide a limit of \$50 per day and a maximum limit of \$1,000.

6. LOAN/LEASE GAP COVERAGE

Under SECTION III - PHYSICAL DAMAGE COVERAGE, in the event of a total "loss" to a covered "auto", we will pay your additional legal obligation for any difference between the actual cash value of the "auto" at the time of the "loss" and the "outstanding balance" of the loan/lease.

"Outstanding balance" means the amount you owe on the loan/lease at the time of "loss" less any amounts representing taxes; overdue payments; penalties, interest or charges resulting from overdue payments; additional mileage charges; excess wear and tear charges; lease termination fees; security deposits not returned by the lessor; costs for extended warranties, credit life Insurance, health, accident or disability insurance purchased with the loan or lease; and carry-over balances from previous loans or leases.

7. AIRBAG COVERAGE

Under Paragraph B. EXCLUSIONS - of SECTION III - PHYSICAL DAMAGE COVERAGE, the following is added:

The exclusion relating to mechanical breakdown does not apply to the accidental discharge of an airbag.

8. ELECTRONIC EQUIPMENT - BROADENED COVERAGE

a. The exceptions to Paragraphs B.4 - EXCLUSIONS - of SECTION III - PHYSICAL DAMAGE COVERAGE are replaced by the following:

Exclusions **4.c.** and **4.d.** do not apply to equipment designed to be operated solely by use of the power from the "auto's" electrical system that, at the time of "loss", is:

- (1) Permanently installed in or upon the covered "auto";
- (2) Removable from a housing unit which is permanently installed in or upon the covered "auto";
- (3) An integral part of the same unit housing any electronic equipment described in Paragraphs (1) and (2) above; or

- (4) Necessary for the normal operation of the covered "auto" or the monitoring of the covered "auto's" operating system.

b. Section III – Version CA 00 01 03 10 of the Business Auto Coverage Form, Physical Damage Coverage, Limit of Insurance, Paragraph C.2 and Version CA 00 01 10 01 of the Business Auto Coverage Form, Physical Damage Coverage, Limit of Insurance, Paragraph C are each amended to add the following:

\$1,500 is the most we will pay for "loss" in any one "accident" to all electronic equipment (other than equipment designed solely for the reproduction of sound, and accessories used with such equipment) that reproduces, receives or transmits audio, visual or data signals which, at the time of "loss", is:

- (1) Permanently installed in or upon the covered "auto" in a housing, opening or other location that is not normally used by the "auto" manufacturer for the installation of such equipment;
- (2) Removable from a permanently installed housing unit as described in Paragraph 2.a. above or is an integral part of that equipment; or
- (3) An integral part of such equipment.

c. For each covered "auto", should loss be limited to electronic equipment only, our obligation to pay for, repair, return or replace damaged or stolen electronic equipment will be reduced by the applicable deductible shown in the Declarations, or \$250, whichever deductible is less.

9. EXTRA EXPENSE - BROADENED COVERAGE

Under Paragraph A. - COVERAGE - of SECTION III - PHYSICAL DAMAGE COVERAGE, we will pay for the expense of returning a stolen covered "auto" to you.

10. GLASS REPAIR - WAIVER OF DEDUCTIBLE

Under Paragraph D. - DEDUCTIBLE - of SECTION III - PHYSICAL DAMAGE COVERAGE, the following is added:

No deductible applies to glass damage if the glass is repaired rather than replaced.

11. TWO OR MORE DEDUCTIBLES

Under Paragraph D. - DEDUCTIBLE - of SECTION III - PHYSICAL DAMAGE COVERAGE, the following is added:

If another Hartford Financial Services Group, Inc. company policy or coverage form that is not an automobile policy or coverage form applies to the same "accident", the following applies:

- (1) If the deductible under this Business Auto Coverage Form is the smaller (or smallest) deductible, it will be waived;
- (2) If the deductible under this Business Auto Coverage Form is not the smaller (or smallest) deductible, it will be reduced by the amount of the smaller (or smallest) deductible.

12. AMENDED DUTIES IN THE EVENT OF ACCIDENT, CLAIM, SUIT OR LOSS

The requirement in LOSS CONDITIONS 2.a. - DUTIES IN THE EVENT OF ACCIDENT, CLAIM, SUIT OR LOSS - of SECTION IV - BUSINESS AUTO CONDITIONS that you must notify us of an "accident" applies only when the "accident" is known to:

- (1) You, if you are an individual;
- (2) A partner, if you are a partnership;
- (3) A member, if you are a limited liability company; or
- (4) An executive officer or insurance manager, if you are a corporation.

13. UNINTENTIONAL FAILURE TO DISCLOSE HAZARDS

If you unintentionally fail to disclose any hazards existing at the inception date of your policy, we will not deny coverage under this Coverage Form because of such failure.

14. HIRED AUTO - COVERAGE TERRITORY

Paragraph e. of GENERAL CONDITIONS 7. - POLICY PERIOD, COVERAGE TERRITORY - of SECTION IV - BUSINESS AUTO CONDITIONS is replaced by the following:

- e. For short-term hired "autos", the coverage territory with respect to Liability Coverage is anywhere in the world provided that if the "insured's" responsibility to pay damages for "bodily injury" or "property damage" is determined in a "suit," the "suit" is brought in the United States of America, the territories and possessions of the United States of America, Puerto Rico or Canada or in a settlement we agree to.

15. WAIVER OF SUBROGATION

TRANSFER OF RIGHTS OF RECOVERY AGAINST OTHERS TO US - of SECTION IV - BUSINESS AUTO CONDITIONS is amended by adding the following:

We waive any right of recovery we may have against any person or organization with whom you have a written contract that requires such waiver because of payments we make for damages under this Coverage Form.

16. RESULTANT MENTAL ANGUISH COVERAGE

The definition of "bodily injury" in SECTION V-DEFINITIONS is replaced by the following:

"Bodily injury" means bodily injury, sickness or disease sustained by any person, including mental anguish or death resulting from any of these.

17. EXTENDED CANCELLATION CONDITION

Paragraph 2. of the COMMON POLICY CONDITIONS - CANCELLATION - applies except as follows:

If we cancel for any reason other than nonpayment of premium, we will mail or deliver to the first Named Insured written notice of cancellation at least 60 days before the effective date of cancellation.

18. HYBRID, ELECTRIC, OR NATURAL GAS VEHICLE PAYMENT COVERAGE

In the event of a total loss to a "non-hybrid" auto for which Comprehensive, Specified Causes of Loss, or Collision coverages are provided under this Coverage Form, then such Physical Damage Coverages are amended as follows:

- a. If the auto is replaced with a "hybrid" auto or an auto powered solely by electricity or natural gas, we will pay an additional 10%, to a maximum of \$2,500, of the "non-hybrid" auto's actual cash value or replacement cost, whichever is less,
- b. The auto must be replaced and a copy of a bill of sale or new lease agreement received by us within 60 calendar days of the date of "loss,"

c. Regardless of the number of autos deemed a total loss, the most we will pay under this Hybrid, Electric, or Natural Gas Vehicle Payment Coverage provision for any one "loss" is \$10,000.

For the purposes of the coverage provision,

- a. A "non-hybrid" auto is defined as an auto that uses only an internal combustion engine to move the auto but does not include autos powered solely by electricity or natural gas.
- b. A "hybrid" auto is defined as an auto with an internal combustion engine and one or more electric motors; and that uses the internal combustion engine and one or more electric motors to move the auto, or the internal combustion engine to charge one or more electric motors, which move the auto.

19. VEHICLE WRAP COVERAGE

In the event of a total loss to an "auto" for which Comprehensive, Specified Causes of Loss, or Collision coverages are provided under this Coverage Form, then such Physical Damage Coverages are amended to add the following:

In addition to the actual cash value of the "auto", we will pay up to \$1,000 for vinyl vehicle wraps which are displayed on the covered "auto" at the time of total loss. Regardless of the number of autos deemed a total loss, the most we will pay under this Vehicle Wrap Coverage provision for any one "loss" is \$5,000. For purposes of this coverage provision, signs or other graphics painted or magnetically affixed to the vehicle are not considered vehicle wraps.



THIS ENDORSEMENT CHANGES THE POLICY. PLEASE READ IT CAREFULLY.

GENERAL CHANGE ENDORSEMENT

Policy Change
Number 007

POLICY NUMBER EPK-145683	POLICY CHANGES EFFECTIVE 11/01/2023	COMPANY Crum and Forster Specialty Insurance Company		
NAMED INSURED Groundwater Solutions, Inc.				
COVERAGE PARTS AFFECTED ERRORS AND OMISSIONS LIABILITY COVERAGE PART				
<p style="text-align: center;">CHANGES</p> <p>In consideration of the premium charged, it is hereby agreed the below is added to the policy:</p> <p style="text-align: center;">AMENDED WAIVER OF TRANSFER OF RIGHTS OF RECOVERY AGAINST OTHERS TO US</p> <p style="text-align: center;">SCHEDULE</p>				
<table border="1" style="width: 100%;"> <tr> <td data-bbox="139 1142 1495 1178">Name of Person(s) or Organization(s)</td> </tr> <tr> <td data-bbox="139 1184 1495 1325">Blanket when specifically required in a written contract with the Named Insured</td> </tr> </table>			Name of Person(s) or Organization(s)	Blanket when specifically required in a written contract with the Named Insured
Name of Person(s) or Organization(s)				
Blanket when specifically required in a written contract with the Named Insured				
Information required to complete this Schedule, if not shown above, will be shown in the Declarations.				
<p>SECTION VI – COMMON CONDITIONS, item 17. Transfer Of Rights of Recovery Against Others To Us within the Common Provisions is amended by the addition of the following:</p> <p>Solely as respects the person(s) or organization(s) indicated in the Schedule shown above, we waive any right of recovery we may have against the person(s) or organization(s) indicated in the Schedule shown above because of payments we make for “damages” arising out of your ongoing operations or “your work” performed under a written contract with that person(s) or organization(s) and included in the “products-completed operations hazard”.</p> <p>However, this waiver shall not apply to “damages” resulting from the sole negligence of the person(s) or organization(s) indicated in the Schedule shown above.</p> <p style="text-align: center;">ALL OTHER TERMS AND CONDITIONS OF THE POLICY REMAIN UNCHANGED</p>				

Authorized Representative Signature



THIS ENDORSEMENT CHANGES THE POLICY. PLEASE READ IT CAREFULLY.

GENERAL CHANGE ENDORSEMENT

Policy Change
Number 008

POLICY NUMBER EPK-145683	POLICY CHANGES EFFECTIVE 11/01/2023	COMPANY Crum and Forster Specialty Insurance Company		
NAMED INSURED Groundwater Solutions, Inc.				
COVERAGE PARTS AFFECTED CONTRACTORS POLLUTION LIABILITY COVERAGE PART THIRD PARTY POLLUTION LIABILITY COVERAGE PART				
<p style="text-align: center;">CHANGES</p> <p>In consideration of the premium charged, it is hereby agreed the below is added to the policy:</p> <p style="text-align: center;">PRIMARY AND NON-CONTRIBUTORY ADDITIONAL INSURED WITH WAIVER OF SUBROGATION</p> <p style="text-align: center;">SCHEDULE</p> <table border="1" style="width: 100%;"> <tr> <td data-bbox="139 1171 1495 1205">Name of Additional Insured Person(s) or Organization(s)</td> </tr> <tr> <td data-bbox="139 1205 1495 1297">Blanket when specifically required in a written contract with the Named Insured</td> </tr> </table>			Name of Additional Insured Person(s) or Organization(s)	Blanket when specifically required in a written contract with the Named Insured
Name of Additional Insured Person(s) or Organization(s)				
Blanket when specifically required in a written contract with the Named Insured				
<p>A. SECTION III – WHO IS AN INSURED within the Common Provisions is amended to include as an additional insured the person(s) or organization(s) indicated in the Schedule shown above, but solely with respect to “claims” caused in whole or in part, by “your work” for that person or organization performed by you, or by those acting on your behalf.</p> <p>This insurance shall be primary and non-contributory, but only in the event of a named insured’s sole negligence.</p> <p>B. We waive any right of recovery we may have against the person(s) or organization(s) indicated in the Schedule shown above because of payments we make for “damages” arising out of “your work” performed under a designated project or contract with that person(s) or organization(s).</p> <p>C. This Endorsement does not reinstate or increase the Limits of Insurance applicable to any “claim” to which the coverage afforded by this Endorsement applies.</p> <p style="text-align: center;">ALL OTHER TERMS AND CONDITIONS OF THE POLICY REMAIN UNCHANGED</p>				

Authorized Representative Signature



< Business Lookup

License Information:

[New search](#) [Back to results](#)

Entity name: GROUNDWATER SOLUTIONS, INC.

Business name: GROUNDWATER SOLUTIONS, INC.

Entity type: Profit Corporation

UBI #: 602-124-908

Business ID: 001

Location ID: 0002

Location: Active

Location address: 650 NE HOLLADAY ST
STE 900
PORTLAND OR 97232-3673

Mailing address: 650 NE HOLLADAY ST
STE 900
PORTLAND OR 97232-3673



Excise tax and reseller permit status:

[Click here](#)

Secretary of State status:

[Click here](#)

Endorsements

Endorsements held at this lo	License #	Count	Details	Status	Expiration da	First issuance
Eatonville General Business - Non-Resident				Active	Apr-30-2025	May-06-2022
Kennewick General Business - Non-Resident				Active	Apr-30-2025	May-12-2017
Pasco General Business - Non-Resident	36915			Active	Apr-30-2025	Oct-13-2020
Ridgefield General Business - Non-Resident	00636			Active	Apr-30-2025	Feb-21-2018
Spokane General Business - Non-Resident	T12107745BL			Active	Apr-30-2025	Oct-15-2012
Vancouver General Business - Non-Resident				Active	Apr-30-2025	Mar-10-2016

Governing People May include governing people not registered with Secretary of State



Governing people**Title**

HAUPT, SUSAN

IGLORIA, RONAN

JANSSEN, KENNY

JOHNSON, MICHAEL

O'ROURKE, DAVID

PARISI, LAURA

PORCELLO, JOHN

POZOS, NICKI

Registered Trade Names

Registered trade names**Status****First issued**

GROUNDWATER SOLUTIONS, INC.

Active

Jun-19-2001

GSI WATER SOLUTIONS

Active

Jun-10-2005

[View Additional Locations](#)

The Business Lookup information is updated nightly. Search date and time:
6/28/2024 9:29:08 AM

Contact us

How are we doing?

Take our survey!

Don't see what you expected?

Check if your browser is supported





Agenda Sheet for City Council:

Committee: PIES **Date:** 07/15/2024

Committee Agenda type: Consent

Date Rec'd 7/15/2024

Clerk's File # OPR 2024-0613

Cross Ref # OPR 2023-0828

Project #

Council Meeting Date: 08/12/2024

Submitting Dept	PUBLIC WORKS	Bid #	
------------------------	--------------	--------------	--

Contact Name/Phone	KATHERINE 625-6822	Requisition #	
---------------------------	--------------------	----------------------	--

Contact E-Mail	KEMILLER@SPOKANECITY.ORG		
-----------------------	--------------------------	--	--

Agenda Item Type	Contract Item		
-------------------------	---------------	--	--

Council Sponsor(s)	BWILKERSON JBINGLE KKLITZKE		
---------------------------	-----------------------------	--	--

Agenda Item Name	5200 – REIMBURSEMENT AGREEMENT WITH SPOKANE TRANSIT AUTHORITY		
-------------------------	---	--	--

Agenda Wording

Reimbursement Agreement with Spokane Transit Authority (STA) for the Division Street Bus Rapid Transit (BRT) Project Development.

Summary (Background)

Spokane Transit Authority (STA) approached the City of Spokane with a request for additional assistance during their Division Street BRT project. Council approved the initial agreement which covered the preliminary engineering phase of the project. The project has since progressed into the design stage which requires a new agreement due to the funding requirements STA must follow.

Lease? NO Grant related? NO Public Works? NO

Fiscal Impact

Approved in Current Year Budget? YES

Total Cost \$

Current Year Cost \$

Subsequent Year(s) Cost \$

Narrative

Amount

Budget Account

Neutral	\$ 100,000.00	# 4250 30210 99999 33847 99999
Select	\$	#
Select	\$	#
Select	\$	#
	\$	#
	\$	#



Continuation of Wording, Summary, Approvals, and Distribution

Agenda Wording

Summary (Background)

Approvals

Dept Head

FEIST, MARLENE

Division Director

FEIST, MARLENE

Accounting Manager

ALBIN-MOORE, ANGELA

Legal

HARRINGTON,

For the Mayor

PICCOLO, MIKE

Additional Approvals

Distribution List

jrhall@spokanecity.org

eraea@spokanecity.org

kemiller@spokanecity.org

mfeist@spokanecity.org

Jordan Hayes-Horton

Committee Agenda Sheet

Public Infrastructure, Environment & Sustainability Committee

Committee Date	July 15 th , 2024
Submitting Department	Public Works
Contact Name	Marlene Feist
Contact Email & Phone	mfeist@spokanecity.org
Council Sponsor(s)	Wilkerson, Bingle, Klitzke
Select Agenda Item Type	<input checked="" type="checkbox"/> Consent <input type="checkbox"/> Discussion Time Requested:
Agenda Item Name	Reimbursement Agreement with Spokane Transit Authority
Proposed Council Action	<input checked="" type="checkbox"/> Approval to proceed to Legislative Agenda <input type="checkbox"/> Information Only
Summary (Background) *use the Fiscal Impact box below for relevant financial information	<p>Spokane Transit Authority (STA) approached the City of Spokane with a request for additional assistance during their Division Street BRT project. Council approved the initial agreement which covered the preliminary engineering phase of the project. The project has since progressed into the design stage which requires a new agreement due to the funding requirements STA must follow. The new agreement would reimburse the City for time spent by the Director of Strategic Initiatives & Development in support of STA’s project similar to the last agreement.</p> <p>City costs eligible for reimbursement by STA include, but are not limited to, direct and indirect costs associated with time engaged by the City Director – Strategic Initiatives & Development in planning, coordinating and participating in support of the Division Street Bus Rapid Transit Preliminary Engineering and Scoping Phase. Example activities include participation in meetings related to the Project, workflow support as it pertains to City input, coordinating City responses, coordination with other agencies as needed, and conflict resolution.</p> <p>The Term of this Agreement shall retroactively commence as of September 30th, 2023, and shall continue until the final date of completion of the Project or the date on which all reimbursement payments have been made by STA, whichever is earlier, unless terminated earlier in accordance with Section Error! Reference source not found. of this agreement.</p>
<p>Fiscal Impact</p> <p>Approved in current year budget? <input type="checkbox"/> Yes <input type="checkbox"/> No <input checked="" type="checkbox"/> N/A</p> <p>Total Cost: <u>Not to exceed \$100,000</u></p> <p>Current year cost:</p> <p>Subsequent year(s) cost:</p> <p>Narrative: Please provide financial due diligence review, as applicable, such as number and type of positions, grant match requirements, summary type details (personnel, maintenance and supplies, capital, revenue), impact on rates, fees, or future shared revenue</p> <p>Funding Source <input checked="" type="checkbox"/> One-time <input type="checkbox"/> Recurring <input type="checkbox"/> N/A</p> <p>Specify funding source: Select Funding Source*</p> <p>Is this funding source sustainable for future years, months, etc? Click or tap here to enter text.</p>	

Expense Occurrence One-time Recurring N/A

Other budget impacts: (revenue generating, match requirements, etc.)

Operations Impacts (If N/A, please give a brief description as to why)

- What impacts would the proposal have on historically excluded communities?
N/A
- How will data be collected, analyzed, and reported concerning the effect of the program/policy by racial, ethnic, gender identity, national origin, income level, disability, sexual orientation, or other existing disparities?
N/A
- How will data be collected regarding the effectiveness of this program, policy, or product to ensure it is the right solution?
N/A
- Describe how this proposal aligns with current City Policies, including the Comprehensive Plan, Sustainability Action Plan, Capital Improvement Program, Neighborhood Master Plans, Council Resolutions, and others?
N/A

Council Subcommittee Review

- Please provide a summary of council subcommittee review. If not reviewed by a council subcommittee, please explain why not.

**DIVISION STREET BUS RAPID TRANSIT
PROJECT DEVELOPMENT
REIMBURSEMENT AGREEMENT**

This Division Street Bus Rapid Transit Project Development Reimbursement Agreement (“Agreement”) is made and entered into by and between the **City of Spokane** (“City”) and the **Spokane Transit Authority** (“STA”); hereinafter each referred to individually as a “Party” and collectively as “Parties”.

WHEREAS, STA is a Public Transportation Benefit Area (“PTBA”) formed under and operating by virtue of the laws of the State of Washington and Chapter 36.57A Revised Code of Washington, and is the designated recipient of formula and discretionary funding from the Federal Transit Administration (“FTA”) within the Spokane Urbanized Area; and

WHEREAS, as part of *Connect Spokane*, STA’s comprehensive plan for public transportation in the PTBA, STA has commenced preliminary design & planning efforts to deliver its Division Bus Rapid Transit (“BRT”) Project (“Project” or “Division BRT”); and

WHEREAS, on September 20, 2023, the Federal Transit Administration (“FTA”) granted STA permission to enter into the project development phase of the Capital Investment Grant Small Starts Program for the Project; and

WHEREAS, the project development phase allows STA, prior to final grant approval, to utilize pre-award authority to incur costs for project development and retain FTA grant eligibility for said costs providing that relevant federal requirements are met; and

WHEREAS, the City, in concert with the Washington State Department of Transportation (“WSDOT”), is responsible for the planning, design and development of street infrastructure along the Division Street Corridor (“Corridor”); and

WHEREAS, STA and the City desire to collaborate on expectations, engineering and design efforts, requirements, permitting and construction of BRT improvements in the Corridor public right of way; and

WHEREAS, STA desires to provide for the reimbursement of certain costs incurred by the City for and related to the project development phase of STA’s Division BRT project.

NOW THEREFORE, in consideration of mutual promises and covenants contained herein, the Parties agree to the terms and conditions as follows:

1. PURPOSE

The purpose of this Agreement is to set forth the terms and conditions upon which STA shall reimburse the City for certain costs incurred by the City relating to the project development and related matters thereto during STA’s project development phase of the Project.

2. TERM

The Term of this Agreement shall retroactively commence as of September 30, 2023, and shall continue until the final date of completion of the Project or the date on which all reimbursement payments have been made by STA, whichever is earlier, unless terminated earlier in accordance with Section 12.

3. RATIFICATION

Acts taken since September 30, 2023, in conformity with the Agreement prior to its execution are hereby ratified and affirmed.

4. COST REIMBURSEMENT

- A. STA will reimburse the City for certain costs identified in this Agreement incurred by the City during the preliminary design and engineering phase of the Project.
- B. City costs eligible for reimbursement include, but are not limited to, direct and indirect costs associated with time engaged by the City Director – Strategic Initiatives & Development in planning, coordinating and participating in support of the Division Street Bus Rapid Transit Preliminary Engineering and Scoping Phase. Example activities include without limitation, participation in meetings related to the Project, workflow support as it pertains to City input, coordinating City responses, coordination with other agencies as needed, and conflict resolution. Bi-weekly meetings between the City Director – Strategic Initiatives & Development and the STA Senior Project Manager will be held to review the work items that were performed by the City Director – Strategic Initiatives & Development.
- C. All reimbursement payments made by STA to City under this Agreement shall be made with local and federal funds.

5. BUDGET

The total cost of reimbursed expenses pursuant to this Agreement shall not exceed \$100,000.00 (one hundred thousand dollars and zero cents) (“Budget”). Any costs in excess of the Budget shall be approved by the Parties in writing as an amendment to this Agreement.

6. INVOICING

- A. The City shall submit to STA quarterly invoices which shall include, by way of example and not limitation, the description of the work performed, the time period in which the work was performed, the hours worked, and the hourly rate for any labor performed. For consumables and materials, if any, an itemized invoice shall include, by way of example and not limitation, a description of the consumable or material, the total quantity, unit prices, and line-item total. Third-party reimbursable costs shall be supported by copies of all third-party invoices, receipts and similar records to fully substantiate the third-party costs. Third-party costs shall not be subject to any markup or additional fee.
 - 1) The first invoice after execution of the Agreement shall include all work performed from January 1, 2024, to the month prior to the date of execution of the Agreement, after which the City will invoice quarterly.

B. Upon receipt of an invoice from the City, STA shall review such invoice for payment. Payment shall be made within thirty (30) days of invoice receipt. Provided, in the event STA has questions about any cost or amount submitted by the City for reimbursement, STA shall notify the City of such questions in writing not later than thirty (30) days after receipt of an invoice. The Parties agree to mutually resolve any invoice questions in good faith, provided, unresolved disputes will be handled pursuant to Section 11 of this Agreement, and STA shall timely process payment for all undisputed invoice costs regardless of the resolution of any dispute. Invoices shall be submitted to the address set forth in Section 8 below.

7. NOTICES

All notices, requests, claims, demands and related communications shall be in writing and shall be signed by a person duly authorized to provide such notice. Notices permitted or requested to be given hereunder shall be deemed sufficient if given (1) in person; (2) by registered or certified mail, postage prepaid, return receipt requested; or (3) by email, addressed to the Parties’ representatives set forth below, or as may be revised by like notice from time to time.

All notices shall be deemed to have been duly received (1) when delivered in person; (2) upon receipt after dispatch by registered or certified mail, postage prepaid; or (3) upon confirmation of read receipt when transmitted by email.

City of Spokane	Spokane Transit Authority
Mike Piccolo City Attorney City Hall, Fifth Floor 808 W Spokane Falls Blvd Spokane, WA 99201 E: mpiccolo@spokanecity.org	Spokane Transit Authority Attn: Contracts 1230 W Boone Ave Spokane, WA 99201 E: contracts@spokanetransit.com

8. COMMUNICATIONS

Any administrative or operational communications required by the Parties shall be directed to the Parties representatives set forth below:

City of Spokane	Spokane Transit Authority
Katherine Miller Director - Strategic Initiatives & Development City of Spokane 808 W Spokane Falls Blvd Spokane, WA 99201 E: kemiller@spokanecity.org P: (509) 625-6338	Karl Otterstrom Chief Planning and Development Officer Spokane Transit Authority 1230 W Boone Ave Spokane, WA 99203 E: kotterstrom@spokanetransit.com P: (509) 325-6089

	<p>Don Skillingstad Senior Project Manager Spokane Transit Authority 1230 W Boone Ave Spokane, WA 99203</p> <p>E: dskillingstad@spokanetransit.com P: (509) 344-1869</p>
--	--

Communications to be given hereunder shall be deemed sufficient if given (1) in person; (2) by mail, postage prepaid; or (3) by email, addressed to the Parties’ representatives set forth above, or as may be revised by written notice in accordance with Section 7 of this Agreement.

9. INDEMNIFICATION

A. STA agrees to indemnify, defend, save and hold harmless the City, its officials, employees, and agents from any and all liability, demands, claims, causes of action, suits or judgments, including costs, attorney fees, and expenses incurred in connection therewith, or whatsoever kind or nature, arising out of, or in connection with, or incident to, the performance of services by STA pursuant to this Agreement.

- 1) In the event that any suit based on such a claim, demand, loss, damage, cost, or cause of action is brought against STA, the City retains the right to participate in said suit if any principle of public law is involved.
- 2) This indemnity and hold harmless shall include any claim made against the City by an employee of STA or subcontractor or agent of STA, even if STA is thus otherwise immune from liability pursuant to the workers' compensation statute, Title 51 RCW, except to the extent that such liability arises from the sole negligence of the City. STA specifically acknowledges that the provisions contained herein have been mutually negotiated by the parties and it is the intent of the parties that ST A provide the broadest scope of indemnity permitted by RCW 4.24.115.

B. The City agrees to indemnify, defend, save, and hold harmless ST A, its officials, employees, and agents from any and all liability, demands, claims, causes of action, suits or judgments, including costs, attorney fees, and expenses incurred in connection therewith, or whatsoever kind or nature, a rising out of, or in connection with, or incident to, the performance of services by City pursuant to this Agreement.

- 1) In the event that any suit based on such a claim, demand, loss, damage, cost, or cause of action is brought against the City, ST A retains the right to participate in said suit if any principle of public law is involved.
- 2) This indemnity and hold harmless shall include any claim mad e against STA by an employee of the City or subcontractor or agent of the City, even if the City is thus otherwise immune from liability pursuant to the workers' compensation statute, Title 51 RCW, except to the extent that such liability arises from the sole negligence of STA. The City specifically acknowledges that the provisions contained herein have been mutually negotiated by the parties and it is the intent of the parties that the City provide the broadest scope of indemnity permitted by RCW 4.24.115.

10. INDEPENDENT CAPACITY

- A. STA and the City are and shall at all times be deemed to be independent contractors in their performance under this Agreement. Nothing herein shall be construed as creating the relationship of employer and employee, or principal and agent, between either Party or between any of their employees. Each Party shall retain all authority for provision of services, standards of performance, discipline and control of its personnel, and other matters incident to its performance pursuant to this Agreement. Nothing in this Agreement shall make any employee of STA an employee of the City or any employee of the City an employee of STA for any purpose, including but not limited to, for withholding of taxes, payment of benefits, workers' compensation pursuant to Title 51 RCW, or any other rights or privileges accorded their respective employees by virtue of their employment.
- B. It is agreed by the Parties that this Agreement does not create a partnership or joint venture relationship between the Parties and does not benefit or create any rights in a third party.

11. DISPUTE RESOLUTION

- A. In the event of any dispute concerning this Agreement, the Parties representatives in Section 8 shall confer to resolve the dispute. These individuals shall use their best efforts and exercise good faith to resolve disputes and issues arising out of or related to this Agreement. In the event the Parties are unable to resolve the dispute, the City's Director - Strategic Initiatives & Development and STA's Chief Planning and Development Officer shall confer and exercise good faith to resolve the dispute.
- B. In the event the City's Director - Strategic Initiatives & Development and STA's Chief Planning and Development Officer are unable to resolve the dispute, the City Mayor and STA's Chief Executive Officer shall engage in good faith negotiations to resolve the dispute.
- C. Any controversy or claim arising out of or relating to this Agreement or the alleged breach of such Agreement that cannot be resolved by the City Mayor and STA's Chief Executive Officer may be submitted to mediation. If still not resolved, the Parties may seek any judicial remedies available in law and equity.
- D. The Parties agree that they shall have no right to seek relief in a court of law until each of these procedural steps is exhausted and if a statute of limitations or statute of repose may lapse during these procedural steps, such statute(s) are deemed tolled until the completion of the above referenced administrative dispute resolution process.

12. TERMINATION

Either Party may terminate this Agreement upon thirty (30) days written notice to the other Party. Termination shall be effected by serving a Notice of Termination in accordance with Section 7 of this Agreement, setting forth the effective date of termination.

If either Party has any property in its possession belonging to the other Party, such Party shall account for same and return it to the other Party or dispose of it in the manner the other Party directs in writing.

13. FORCE MAJEURE

In the event that any Party's obligations under this Agreement are substantially delayed, prevented or rendered impractical by fire, flood, riot, earthquake, civil commotion, war, strike, lockout, labor

disturbance, exposition, sabotage, accident or other casualty, weather event, pandemic, act of God, any law ordinance, rule or regulation which becomes effective after the date of this Agreement, measures of governmental authority including but not limited to any temporary law ordinance, health directive, rule, regulation, travel or movement restriction, or limitation on the size of gatherings implemented by the local health department, board or officer in the jurisdiction where the event is to be held, the Washington State Department of Health, the Governor of the State of Washington, the Washington State Military Department, the United States Department of Health & Human Services, the United States Centers for Disease Control and Prevention, or any other Local, State, or Federal Public Health Agency which adversely affects the ability of either Party to perform its obligations under this Agreement, pandemics, viral or communicable disease outbreak, quarantine or any other cause beyond the reasonable control of any Party, then the Parties shall be released from performance under this Agreement. The Parties hereby waive any claim for damages or compensation for such delay or failure to perform, other than obligations incurred up to the date of such force majeure.

14. NON-DISCRIMINATION

The Parties agree they shall not participate in any discriminatory action against any employee who is paid by funds indicated in this Agreement or against any applicant for such employment because of race, religion, color, sex, marital status, creed, national origin, age, Vietnam era or disabled veterans' status, or the presence of any sensory, mental or physical handicap, or as otherwise provided by applicable law. This provision shall include, but not be limited to, employment, upgrading, demotion, transfer, recruitment, advertising, layoff or termination, rates of pay or other forms of compensation, and selection for training.

15. COMPLIANCE WITH LAWS

Each Party to this Agreement shall comply with all applicable federal, state and local laws and regulations.

16. GOVERNING LAW & VENUE

This Agreement shall be governed by and construed according to the laws of the State of Washington. Nothing in this Agreement shall be construed as altering or diminishing the rights or responsibilities of the Parties as granted or imposed by state law. Any and all disputes concerning this Agreement not resolved in accordance with Section 11 shall be resolved in the Superior Court of Spokane County, Washington. The Parties agree to exclusive personal jurisdiction, subject matter jurisdiction and the venue of this court.

17. ENTIRE AGREEMENT

This Agreement and its attachments, if any, constitute the entire Agreement between the Parties and supersedes all prior negotiations, representations and agreements between the Parties relating to the subject matter hereof.

18. MODIFICATION

This Agreement may be amended or modified only by written instrument signed by the Parties.

19. SEVERABILITY

Should any provision of this Agreement be deemed invalid or inconsistent with any federal, state or local law or regulation, or contrary to public policy, the remaining provisions shall continue in full force and effect. The Parties agree to immediately attempt to renegotiate such provision that is invalidated or superseded by such laws or regulations.

20. SUCCESSORS & ASSIGNS

This Agreement shall be binding on the Parties hereto. Neither Party may delegate the performance of any obligation hereunder to a third party without prior written approval from the other Party.

21. ANTI-KICKBACK

No officer, director, employee, agent or representative of the City of Spokane or the Spokane Transit Authority, having the power or duty to perform an official act or action related to this Agreement, shall have or acquire any interest in the Agreement, or have solicited, accepted or granted a present or future gift, favor, service or other thing of value from or to any person involved in this Agreement.

22. CONFLICT OF INTEREST

No officer, director employee, agent or representative of the City of Spokane or the Spokane Transit Authority shall participate in the selection, award or administration of an agreement or contract if a conflict of interest, real or apparent, would be involved. Such a conflict would arise under the following circumstances, or as otherwise defined by law:

- A. the officer, director, employee, agent or representative;
- B. any member of his/her immediate family;
- C. his or her partner; or
- D. an organization which employs, or is about to employ, any officer, director, employee, agent or representative of STA,

has a financial or other interest in the firm selected for award.

23. TRADEMARKS AND LOGOS

The Parties are prohibited from using, and agree not to use, directly or indirectly, any name, trademark or logo of the other Party without first obtaining prior written consent from the other Party.

24. PUBLIC RECORDS ACT

The Parties understand and acknowledge that the other Party is a municipal corporation of the State of Washington subject to the "Public Records Act", RCW 42.56, *et seq.*

The Parties understand and agree that the records it obtains or produces under this Agreement may be public records under the Public Records Act, or its successor act. The Parties shall cooperate in a timely manner in responding to a public records request ("PRR") related to this Agreement or any deliverable or work performed hereunder. Such cooperation shall include searching all records regarding this Agreement or any deliverable or work performed hereunder, and producing all records that are

potentially responsive to a PRR to the requesting Party. The Parties shall not charge the requesting Party for the time spent gathering and producing records pursuant to a PRR.

25. AUDIT/RECORDS

The Parties shall maintain for a minimum of three (3) years following final payment or expiration of this Agreement, whichever occurs later, all records related to its performance of this Agreement. A Party may audit any record related to this Agreement for any reason and the audited Party shall provide copies of and access to, at reasonable times, any such record upon request by the requesting Party. The Parties shall also provide access to authorized representatives of the Washington State Auditor's Office at reasonable times and in a reasonable manner to inspect and copy any such record. In the event of conflict between this provision and related auditing provisions required under federal law applicable to this Agreement, the federal law shall prevail.

Records and other documents, in any medium, furnished by any Party to another party will remain the property of the furnishing Party, unless otherwise agreed in writing. Subject to Section 24 of this Agreement, the receiving Party will not disclose or make available any confidential information to any third parties without first giving notice to the furnishing Party and giving it a reasonable opportunity to respond. Each Party will utilize reasonable security procedures and protections to assure that records and documents provided by the other Party are not erroneously disclosed to third parties.

26. COUNTERPARTS

This Agreement may be executed in one or more counterparts, each of which shall constitute an original agreement, but all of which together shall constitute one and the same instrument.

27. INCORPORATION OF FEDERAL TERMS & CONDITIONS

This Agreement is funded, in whole or in part, by Federal assistance and is subject to the *Federal Terms & Conditions* attached hereto and incorporated herein as Exhibit A.

28. ELECTRONIC SIGNATURES

A signed copy of this Agreement or any other ancillary agreement transmitted by email or other means of electronic transmission or electronically or digitally executed shall be deemed to have the same legal effect as delivery of any original executed copy of this Agreement or such other ancillary agreement for all purposes.

[signatures on the following page]

29. SIGNATURES

The Parties affirm the individuals signing this Agreement have been granted the authority to do so and by their signature affirm the Parties will comply with the terms and conditions of this Agreement.

City of Spokane

Spokane Transit Authority

By: Lisa Brown
Title: Mayor

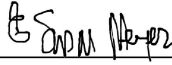
By: E. Susan Meyer
Title: Chief Executive Officer

Date: _____

Date: Jul 3, 2024

Attest:

Attest:

By: Terri Pfister
Title: City Clerk

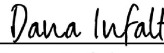
By: Dana Infalt
Title: Clerk of the Authority

Date: _____

Date: Jul 3, 2024

Approved as to form:

Disadvantaged Business Enterprises Compliance

By: Margaret Harrington
Title: Assistant City Attorney

By: Jordan Hayes-Horton
Title: DBE Liaison

Date: _____

Date: Jun 26, 2024

EXHIBIT A

FEDERAL TERMS & CONDITIONS

1. DEFINITIONS

The following capitalized terms shall be defined as follows throughout these Federal Terms & Conditions (“T&C”). In the event of a conflict between these T&C and the document(s) to which they are attached, the terms of these T&C shall prevail.

Terms which are capitalized herein, but not defined hereunder, will have the same definition and meaning as used in the document(s) to which these T&C are attached. In the event of a conflict between the definition of a defined term in these T&C and the document(s) to which they are attached, the definition used in these T&C shall prevail in the interpretation of these T&C.

Term	Definition
ADA	Americans with Disabilities Act of 1990, as amended.
CFR	Code of Federal Regulations
DBE	Disadvantaged Business Enterprise
DOJ	United States Department of Justice
DOL	United States Department of Labor
DOT	United States Department of Transportation
EEOC	Equal Employment Opportunity Commission
EPA	United States Environmental Protection Agency
FHWA	United States Federal Highway Administration
FTA	Federal Transit Administration
GSA	United States General Services Administration
SAT	Federal Simplified Acquisition Threshold; Currently \$250,000.
T&C	These Federal Terms & Conditions.
US	United States of America
USC	United States Code

2. FLY AMERICA

- A. Applicability: All contracts involving transportation of persons or property by air between the US and/or places outside the US.
- B. Contractor shall comply with 49 USC 40118 (the “Fly America” Act) in accordance with General Services Administration regulations 41 CFR 301-10, stating that recipients and subrecipients of Federal funds and their contractors are required to use US Flag air carriers for US Government-financed international air travel and transportation of their personal effects or property, to the extent such service is available, unless travel by foreign air carrier is a matter of necessity, as defined by the Fly America Act. Contractor shall submit, if a foreign air carrier was used, an appropriate certification or memorandum adequately explaining why service by a US flag air carrier was not available or why it was necessary to use a foreign air carrier and shall, in any event, provide a certificate of compliance with the Fly America requirements.
- C. Contractor shall include the requirements of this section in all subcontracts that may involve international air transportation.

3. BUY AMERICA

- A. Applicability: Construction contracts and acquisition of goods or “Rolling Stock” valued at more than \$150,000.
- B. Contractor shall comply with 49 USC 5323(j) and 49 CFR 661, stating that Federal funds may not be obligated unless steel, iron and manufactured products used in FTA-funded projects are

EXHIBIT A

FEDERAL TERMS & CONDITIONS

produced in the United States, unless a waiver has been granted by FTA or the product is subject to a general waiver. General waivers are listed in 49 CFR 661.7, and include software, microcomputer equipment and small purchases (currently less than \$150,000) made with capital, operating or planning funds.

Separate requirements for Rolling Stock are stated at 5323(j)(2)(C) and 49 CFR 661.11. Rolling Stock must be manufactured in the US and have a minimum 65% domestic content for FY2018 and FY2019 and a minimum 70% domestic content for FY2020 and beyond. A Proposer shall submit appropriate Buy America certification to STA with all bids on FTA-funded contracts, except those subject to a general waiver. Proposals not accompanied by a completed Buy America certification shall be rejected as nonresponsive. This requirement does not apply to lower tier subcontractors.

4. CHARTER SERVICE

- A. Applicability: Operational service contracts.
- B. Contractor shall comply with 49 USC 5323(d) and (r) and 49 CFR Part 604, which state that recipients and subrecipients of FTA assistance may not provide charter service using equipment or facilities acquired with Federal assistance if there is at least one private charter operator willing and able to provide the service, except as permitted by:
 - 1) 49 USC 5323(d) or other Federal transit laws;
 - 2) 49 CFR Part 604;
 - 3) Any other federal Charter Service regulations; or
 - 4) Federal guidance, except as FTA determines otherwise in writing.
- C. The Contractor agrees that if it engages in a pattern of violations of FTA's Charter Service regulations, FTA may require corrective measures or impose remedies, which may include:
 - 1) Barring STA, the Contractor, or any subcontractor operating public transportation from receiving Federal assistance;
 - 2) Withholding an amount of federal assistance from STA as provided by Appendix D to 49 Part 604; or
 - 3) Any other appropriate remedy.
- D. Contractor shall include this clause in each subcontract for the operation of public transit services.

5. SCHOOL BUS OPERATIONS

- A. Applicability: Operational service contracts.
- B. Pursuant to 49 USC 5323(f) and 49 CFR Part 605, Contractor and any of its subcontractors shall not engage in school bus operations exclusively for transportation of students and school personnel in competition with private school bus operators unless permitted under specified exemptions. When operating exclusive school bus service under an allowable exemption, Contractor and any of its subcontractors shall not use federally funded equipment, vehicles, or facilities.
- C. Violations. If STA, the Contractor and any of its subcontractors operate school bus service in violation of FTA's School Bus laws and regulations, FTA may:
 - 1) Require STA, the Contractor and any of its subcontractors to take such remedial measures as FTA considers appropriate; or

EXHIBIT A

FEDERAL TERMS & CONDITIONS

- 2) Bar STA, the Contractor and any of its subcontractors from receiving Federal transit funds.

6. CARGO PREFERENCE

- A. Applicability: Contracts involving equipment, materials or commodities which may be transported by ocean vessels.
- B. Contractor shall abide by the provisions of 46 CFR 381 as follows:
 - 1) Use privately owned US-Flag commercial vessels to ship at least 50% of the gross tonnage (computed separately for dry bulk carriers, dry cargo liners, and tankers) involved, whenever shipping any equipment, material, or commodities pursuant to the underlying contract to the extent such vessels are available at fair and reasonable rates for US flag commercial vessels; and
 - 2) Furnish within 20 working days following the loading date of shipments originating within the US or within 30 working days following the loading date of shipments originating outside the US, a legible copy of a rated, "on-board" commercial bill-of-lading in English for each shipment of cargo described herein to the Division of National Cargo, Office of Market Development, Maritime Administration, Washington, DC 20590 and to STA (through contractor in the case of a subcontractor's bill-of-lading.); and
 - 3) include these requirements in all subcontracts issued pursuant to this Contract when the subcontract involves the transport of equipment, material, or commodities by ocean vessel.

7. SEISMIC SAFETY

- A. Applicability: Architectural & Engineering contracts; Construction contracts for new buildings or additions to existing buildings.
- B. Contractor agrees that any new building or addition to an existing building shall be designed and constructed in accordance with the standards required in DOT Seismic Safety Regulations 49 CFR 41 and shall certify compliance to the extent required by the regulation. Contractor shall also ensure that all work performed under this Contract, including work performed by subcontractors, complies with the standards required by 49 CFR 41 and the certification of compliance issued on the project.

8. ENERGY CONSERVATION

- A. Applicability: All contracts.
- B. Contractor shall comply with mandatory standards and policies relating to energy efficiency stated in the Washington State energy conservation plan issued in compliance with the Energy Policy & Conservation Act (42 USC 6201 *et seq.*), and perform an energy assessment for any buildings constructed or altered in accordance with FTA *Requirements for Energy Assessments*, at 49 CFR Part 622, subpart C.

9. CLEAN WATER

- A. Applicability: All contracts and subcontracts over \$150,000.
- B. Contractor shall comply with all applicable standards, orders or regulations issued pursuant to the Federal Water Pollution Control Act, as amended, 33 USC 1251 *et seq.* Contractor shall report each violation to STA and understands and agrees that STA shall, in turn, report each violation as required to FTA and the appropriate EPA Regional Office.

EXHIBIT A

FEDERAL TERMS & CONDITIONS

- C. Contractor shall include these requirements in each subcontract exceeding \$150,000 financed in whole or in part with FTA assistance.

10. **BUS TESTING**

- A. Applicability: Rolling Stock purchase or lease contracts.
- B. Contractor [Manufacturer] shall comply with the Bus Testing requirements under 49 USC5318(e) and FTA's implementing regulation at 49 CFR Part 665 to ensure that the requisite testing is performed for all new bus models, or any bus model with a major change in configuration or components, and that the bus model has achieved a passing score. Upon completion of the testing, the Contractor [Manufacturer] shall obtain a copy of the bus testing reports from the operator of the testing facility and make the report(s) available to the public prior to final acceptance of the first vehicle by STA or another recipient.

11. **PRE-AWARD & POST-DELIVERY AUDIT REQUIREMENTS**

- A. Applicability: Rolling Stock (revenue service) purchases.
- B. Contractor shall comply with 49 USC 5323(m) and FTA's implementing regulation 49 CFR Part 663 and submit the following certifications:
 - 1) Buy America Requirements. Contractor shall complete and submit a declaration certifying either compliance or noncompliance with Buy America. If contractor certifies compliance with Buy America, it shall submit documentation listing:
 - a) Component and subcomponent parts of the rolling stock to be purchased identified by manufacturer of the parts, their country of origin and costs; and
 - b) The location of the final assembly point for the Rolling Stock, including a description of the activities that will take place at the final assembly point and the cost of final assembly.
 - 2) Solicitation Specification Requirements. Contractor shall comply with the Buy America certification(s) submitted with its the bid specifications.
 - 3) Federal Motor Vehicle Safety Standards (FMVSS). Contractor shall submit:
 - a) manufacturer's FMVSS self-certification sticker information that the vehicle complies with relevant FMVSS; or
 - b) manufacturer's certified statement that the buses will not be subject to FMVSS regulations.
- C. Contractor shall participate and cooperate in any pre-award and post-delivery audits performed pursuant to 49 CFR Part 663 and related FTA guidance.

12. **LOBBYING**

- A. Applicability: All contracts over \$100,000.
- B. Contractor shall execute the Lobbying Restriction Certificate attached to this Contract.

13. **ACCESS TO RECORDS AND REPORTS**

- A. Applicability: All contracts.
- B. The following access to records requirements apply to this Contract:

EXHIBIT A

FEDERAL TERMS & CONDITIONS

- 1) Access to Records. Under 49 USC 5325(g), FTA has the right to examine all records, documents, papers, and contracts related to any FTA funded project. Therefore, Contractor shall permit FTA and its contractors' access and rights to reproduce or copy project related documents. Pursuant to 49 CFR Part 633, this provision extends to any Project Management Oversight ("PMO") contractor if the federally funded contract is used in a major capital project as defined therein.
- 2) Records Retention. Pursuant to 2 CFR 200.333 Contractor shall retain, and shall require its subcontractors of all tiers to retain, complete and readily accessible records related in whole or in part to this Contract, including, but not limited to books, accounts, reports, data, documents, statistics, sub-agreements, leases, subcontracts, arrangements other third-party agreements of any type, and supporting materials related to those records for a period of not less than three (3) years after the date of termination or expiration of this Contract, except in the event of litigation or settlement of claims arising from the performance of this Contract, in which case Contractor shall maintain such records until the disposition of all such litigation, appeals, claims or exceptions related thereto.
- 3) Access to the Sites of Performance. The Contractor agrees to permit STA, FTA, and its contractors' access to the sites of performance under this Contract as reasonably may be required.
- 4) Contractors shall include these requirements in their contracts and subcontracts with third parties at every tier.

14. FEDERAL CHANGES

- A. Applicability: All contracts.
- B. Contractor shall comply with all applicable FTA regulations, policies, procedures, and directives, including without limitation those listed directly or by reference in the Master Agreement between STA and FTA, as they may be amended or promulgated from time to time during the term of this Contract. Contractor's failure to comply shall constitute a material breach of this Contract.

15. BONDING REQUIREMENTS

- A. Applicability: All bonds are required for construction or facility improvement contracts or subcontracts exceeding the SAT.
- B. Bid Bond
 - 1) A bid bond equivalent to five percent (5%) of the bid price must be issued by a fully qualified surety company acceptable to STA and listed as a company currently authorized under 31 CFR, Part 223 as possessing a Certificate of Authority as described thereunder.
 - 2) Rights Reserved
 - a) In submitting its bid, it is understood and agreed by Contractor that the right is reserved by STA to reject any and all bids, or part of any bid, and it is agreed that the bid may not be withdrawn for a period of ninety (90) days subsequent to the opening of bids, without the written consent of STA.
 - b) It is also understood and agreed that if the Contractor should withdraw any part or all of its bid within ninety (90) days after the bid opening without the written consent of STA, shall refuse or be unable to enter into this Contract, as provided above, or refuse or be

EXHIBIT A

FEDERAL TERMS & CONDITIONS

unable to furnish adequate and acceptable performance and/or payment bond(s), or refuse or be unable to furnish adequate and acceptable insurance, Contractor shall forfeit its bid bond to the extent of STA's damages occasioned by such withdrawal, or refusal, or inability to enter into a Contract, or provide adequate security therefor.

- c) It is further understood and agreed that to the extent the Contractor's bid bond (excluding any income generated thereby which has been retained by STA as provided in the Instructions to Bidders) shall prove inadequate to fully recompense STA for the damages occasioned by default, then the Contractor agrees to indemnify STA and pay over to STA the difference between the bid bond and STA's total damages, so as to make STA whole.
- d) The Contractor understands that any material alteration of any of the above or any of the material contained on this form, other than that requested, will render the bid unresponsive.

C. Performance and Payment Bonds - Construction. The Contractor shall be required to obtain performance and payment bonds as follows:

1) Performance bonds.

- a) The penal amount of performance bonds shall be one hundred percent (100%) of the original Contract sum, unless FTA determines in writing that a lesser amount would be adequate for the protection of the Federal interest. The bond shall be issued by a fully qualified surety company acceptable to STA and listed as a company currently authorized under 31 CFR Part 223 as possessing a Certificate of Authority as described thereunder.
- b) STA may require additional performance bond protection when the Contract sum is increased. The increase in protection shall generally equal one hundred percent (100%) of the increase in Contract sum. STA may secure additional protection by directing the Contractor to increase the penal amount of the existing bond or to obtain an additional bond.

2) Payment bonds.

- a) The penal amount of the payment bonds shall be one hundred percent (100%) of the original Contract sum, unless FTA determines in writing that a lesser amount would be adequate for the protection of the Federal interest. The bond shall be issued by a fully qualified surety company acceptable to STA and listed as a company currently authorized under 31 CFR Part 223 as possessing a Certificate of Authority as described thereunder.
- b) STA may require additional payment bond protection when the Contract sum is increased. The increase in protection shall generally equal one hundred percent (100%) of the increase in Contract sum. STA may secure additional protection by directing the Contractor to increase the penal amount of the existing bond or to obtain an additional bond.

16. CLEAN AIR

- A. Applicability. All contracts and subcontracts over \$150,000.
- B. Contractor shall comply with all applicable standards, orders, or regulations pursuant to the Clean Air Act, 42 USC 7401 *et seq.* Contractor shall report each violation to STA and understands and agrees that STA will, in turn, report each violation as required to FTA and the appropriate EPA Regional Office.

EXHIBIT A

FEDERAL TERMS & CONDITIONS

- C. Contractor shall include these requirements in each subcontract exceeding \$150,000 financed in whole or in part with FTA assistance.

17. RECYCLED PRODUCTS

- A. Applicability. All contracts for items designated by the EPA when STA or Contractor procures \$10,000 or more of one of these items during the current or previous fiscal year using Federal funds.
- B. The Contractor agrees to provide a preference for those products and services that conserve natural resources, protect the environment and are energy efficient by complying with and facilitating compliance with the requirements of Section 6002 of the Resource Conservation and Recovery Act (RCRA), 42 USC 6962 *et seq.*, as amended, and the US Environmental Protection Agency's regulation titled *Comprehensive Procurement Guideline for Products Containing Recovered Materials*, 40 CFR Part 247.

18. EMPLOYEE PROTECTIONS (DAVIS-BACON AND COPELAND ANTI-KICKBACK ACTS, DOL WORK HOURS AND SAFETY STANDARDS)

- A. Applicability. Construction contracts and subcontracts, including actual construction, alteration and/or repair, including decorating and painting.
- B. Prevailing Wage and Anti-Kickback.

For all prime construction, alteration, or repair contracts in excess of \$2,000 awarded by STA, the Contractor shall comply with the Davis-Bacon Act and the Copeland "Anti-Kickback" Act. Under 49 USC § 5333(a), prevailing wage protections apply to laborers and mechanics employed on FTA assisted construction, alteration, or repair projects. The Contractor will comply with the *Davis-Bacon Act*, 40 USC §§ 3141-3144 and 3146-3148, as supplemented by DOL regulations at 29 CFR Part 5, *Labor Standards Provisions Applicable to Contracts Governing Federally Financed and Assisted Construction*. In accordance with the statute, the Contractor shall pay wages to laborers and mechanics at a rate not less than the prevailing wages specified in a wage determination made by the Secretary of Labor. In addition, the Contractor agrees to pay wages not less than once per week. The Contractor shall also comply with the *Copeland "Anti-Kickback" Act*, 40 USC § 3145, as supplemented by DOL regulations at 29 CFR Part 3, *Contractors and Subcontractors on Public Building or Public Work Financed in Whole or in part by Loans or Grants from the United States*. The Contractor is prohibited from inducing, by any means, any person employed in the construction, completion, or repair of public work, to give up any part of the compensation to which he or she is otherwise entitled.

19. CONTRACT WORK HOURS & SAFETY STANDARDS ACT - CONSTRUCTION CONTRACTS

- A. Applicability. Construction contracts over \$100,000.
- B. Contract Work Hours and Safety Standards.
- 1) For all construction contracts in excess of \$100,000 that involve the employment of mechanics or laborers, the Contractor shall comply with the *Contract Work Hours and Safety Standards Act*, 40 USC §§ 3701-3708, as supplemented by the DOL regulations at 29 CFR Part 5. Under 40 USC § 3702 of the Act, the Contractor shall compute the wages of every mechanic and laborer, including watchmen and guards, on the basis of a standard work week of forty (40) hours. Work in excess of the standard work week is permissible provided that the worker is compensated at a rate of not less than one and a half (1-1/2) times the basic rate of pay for all hours worked in excess of forty (40) hours in the work week. The requirements

EXHIBIT A

FEDERAL TERMS & CONDITIONS

of 40 USC § 3704 are applicable to construction work and provide that no laborer or mechanic be required to work in surroundings or under working conditions which are unsanitary, hazardous, or dangerous. These requirements do not apply to the purchase of supplies or materials or articles ordinarily available on the open market, or to contracts for transportation or transmission of intelligence.

- 2) In the event of any violation of the clause set forth herein, the Contractor and any subcontractor responsible therefor shall be liable for the unpaid wages. In addition, the Contractor and subcontractor shall be liable to the United States (in the case of work done under contract for the District of Columbia or a territory, to such District or to such territory), for liquidated damages. Such liquidated damages shall be computed with respect to each individual laborer or mechanic, including watchmen and guards, employed in violation of this clause in the sum of \$10 for each calendar day on which such individual was required or permitted to work in excess of the standard workweek of forty (40) hours without payment of the overtime wages required by this clause.
- 3) STA or the FTA shall, upon its own action or upon written request of an authorized representative of the Department of Labor, withhold or cause to be withheld, from any moneys payable on account of work performed by the Contractor or subcontractor under any such contract or any other Federal contract with the same prime Contractor, or any other federally-assisted contract subject to the *Contract Work Hours and Safety Standards Act*, which is held by the same prime Contractor, such sums as may be determined to be necessary to satisfy any liabilities of such Contractor or subcontractor for unpaid wages and liquidated damages as provided in this section.
- 4) Contractor or subcontractor shall insert in any subcontracts the clauses set forth in this Section and also a clause requiring the subcontractors to include these clauses in any lower tier subcontracts. Contractor shall be responsible for compliance by any subcontractor or lower tier subcontractor with the clauses set forth in this Section.

20. CONTRACT WORK HOURS & SAFETY STANDARDS ACT – NON-CONSTRUCTION CONTRACTS

A. Applicability. Non-construction contracts over \$100,000.

- 1) The Contractor shall comply with all federal laws, regulations and requirements providing wage and hour protections for non-construction employees, in accordance with 40 USC § 3702, *Contract Work Hours and Safety Standards Act*, and other relevant parts of that Act, 40 USC § 3701 *et seq.*, and US DOL regulations, *Labor Standards Provisions Applicable to Contracts Covering Federally Financed and Assisted Construction (also Labor Standards Provisions Applicable to Non-construction Contracts Subject to the Contract Work Hours and Safety Standards Act)*, 29 CFR Part 5.
- 2) The Contractor shall maintain payrolls and basic payroll records during the course of the work and shall preserve them for a period of three (3) years from the completion of the Contract for all laborers and mechanics, including guards and watchmen, working on the Contract. Such records shall contain the name and address of each such employee, social security number, correct classifications, hourly rates of wages paid, daily and weekly number of hours worked, deductions made, and actual wages paid.
- 3) Such records maintained under this paragraph shall be made available by the Contractor for inspection, copying or transcription by authorized representatives of the FTA and the

EXHIBIT A

FEDERAL TERMS & CONDITIONS

Department of Labor, and the Contractor will permit such representatives to interview employees during working hours on the job.

- 4) The Contractor shall require the inclusion of the language of this clause within subcontracts of all tiers.

21. NO GOVERNMENT OBLIGATION TO THIRD PARTIES

- A. Applicability. All contracts.
- B. STA and Contractor acknowledge and agree that, notwithstanding any concurrence by the US Government in or approval of the solicitation or award of the underlying Contract, absent the express written consent by the US Government, the US Government is not a party to this Contract and shall not be subject to any obligations or liabilities to STA, the Contractor, or any other party (whether or not a party to this Contract) pertaining to any matter resulting from the underlying Contract.
- C. Contractor agrees to include the above clause in each subcontract financed in whole or in part with FTA assistance. It is further agreed that the clause shall not be modified, except to identify the subcontractor who will be subject to its provisions.

22. PROGRAM FRAUD AND FALSE OR FRAUDULENT STATEMENTS OR RELATED ACTS

- A. Applicability. All contracts.
- B. Contractor acknowledges that the provisions of the Program Fraud Civil Remedies Act of 1986, as amended, 31 USC 3801 *et seq.*, and DOT regulations, *Program Fraud Civil Remedies*, 49 CFR 31, apply to its actions pertaining to this Contract. Upon execution of the underlying Contract, Contractor certifies or affirms the truthfulness and accuracy of any statement it has made, it makes, it may make or causes to be made, pertaining to the underlying Contract or FTA assisted project for which this Contract work is being performed. In addition to other penalties that may be applicable, Contractor further acknowledges that if it makes, or causes to be made, a false, fictitious, or fraudulent claim, statement, submittal or certification, the US Government reserves the right to impose the penalties of the Program Fraud Civil Remedies Act (1986) on Contractor to the extent the US Government deems appropriate.
- C. If Contractor makes, or causes to be made, a false, fictitious, or fraudulent claim, statement, submittal, or certification to the US Government under a contract connected with a project that is financed in whole or in part with FTA assistance under the authority of 49 USC 5307, the Government reserves the right to impose the penalties of 18 USC 1001 and 49 USC 5323(l)(1) on Contractor, to the extent the US Government deems appropriate.
- D. Contractor shall include the above two clauses in each subcontract financed in whole or in part with FTA assistance. The clauses shall not be modified, except to identify the subcontractor who will be subject to the provisions.

23. GOVERNMENT-WIDE DEBARMENT AND SUSPENSION

- A. Applicability. Contracts over \$25,000.
- B. The Contractor agrees to the following:
 - 1) It will comply with the requirements of 2 CFR Part 180, subpart C, as adopted and supplemented by DOT regulations at 2 CFR Part 1200, which include the following:

EXHIBIT A

FEDERAL TERMS & CONDITIONS

- a) It will not enter into any arrangement to participate in the development or implementation of the Contract with any third-party that is debarred or suspended except as authorized by:
 - (1) DOT regulations, *Nonprocurement Suspension and Debarment*;
 - (2) 2 CFR Part 1200, US OMB, *Guidelines to Agencies on Governmentwide Debarment and Suspension (Nonprocurement)*;
 - (3) 2 CFR Part 180, including any amendments thereto; and
 - (4) Executive Orders Nos. 12549 and 12689, *Debarment and Suspension*, 31 USC § 6101 note.
- b) It will review the GSA “System for Award Management” (<https://www.sam.gov>), if required by DOT regulations, 2 CFR Part 1200.
- c) It will include, and require each of its third-party contractors to include, a similar provision in each lower tier covered transaction, ensuring that each lower tier third-party:
 - (1) Will comply with Federal debarment and suspension requirements; and
 - (2) Review the System for Award Management (<https://www.sam.gov>), if necessary, to comply with DOT regulations, 2 CFR Part 1200; and
- 2) If Contractor suspends, debars, or takes any similar action against a third-party or individual, Contractor will provide immediate written notice to the:
 - a) STA;
 - b) FTA Regional Counsel for the Region in which STA is located or implements the project;
 - c) FTA Project Manager if the project is administered by an FTA Headquarters Office; or
 - d) FTA Chief Counsel.

24. CIVIL RIGHTS REQUIREMENTS

A. Applicability. All contracts.

B. STA is an Equal Opportunity Employer. As such, STA agrees to comply with all applicable Federal civil rights laws and implementing regulations. Apart from inconsistent requirements imposed by Federal laws or regulations, STA agrees to comply with the requirements of 49 USC § 5323(h)(3) by not using any Federal assistance awarded by FTA to support procurements using exclusionary or discriminatory specifications.

Under this Contract, the Contractor shall at all times comply with the following requirements and shall include these requirements in each subcontract entered into as part thereof.

- 1) Nondiscrimination. In accordance with Federal transit law at 49 USC § 5332, the Contractor agrees that it will not discriminate against any employee or applicant for employment because of race, color, religion, national origin, sex, disability, or age. In addition, the Contractor agrees to comply with applicable Federal implementing regulations and other implementing requirements FTA may issue.
- 2) Race, Color, Religion, National Origin, Sex. In accordance with Title VII of the Civil Rights Act, as amended, 42 USC § 2000e *et seq.*, and Federal transit laws at 49 USC § 5332, the Contractor agrees to comply with all applicable equal employment opportunity requirements of US DOL regulations, *Office of Federal Contract Compliance Programs, Equal*

EXHIBIT A

FEDERAL TERMS & CONDITIONS

Employment Opportunity, Department of Labor, 41 CFR chapter 60, and Executive Order No. 11246, Equal Employment Opportunity in Federal Employment, September 24, 1965, 42 USC § 2000e note, as amended by any later Executive Order that amends or supersedes it, referenced in 42 USC § 2000e note. The Contractor agrees to take affirmative action to ensure that applicants are employed, and that employees are treated during employment, without regard to their race, color, religion, national origin, or sex (including sexual orientation and gender identity). Such action shall include, but not be limited to, the following: employment, promotion, demotion or transfer, recruitment or recruitment advertising, layoff, or termination; rates of pay or other forms of compensation; and selection for training, including apprenticeship. In addition, the Contractor agrees to comply with any implementing requirements FTA may issue.

- 3) Age. In accordance with the Age Discrimination in Employment Act, 29 USC §§ 621-634, US Equal Employment Opportunity Commission (US EEOC) regulations, *Age Discrimination in Employment Act, 29 CFR Part 1625, the Age Discrimination Act of 1975, as amended, 42 USC § 6101 et seq., US Health and Human Services regulations, Nondiscrimination on the Basis of Age in Programs or Activities Receiving Federal Financial Assistance, 45 CFR Part 90, and Federal transit law at 49 USC § 5332, the Contractor agrees to refrain from discrimination against present and prospective employees for reason of age. In addition, the Contractor agrees to comply with any implementing requirements FTA may issue.*
- 4) Disabilities. In accordance with section 504 of the Rehabilitation Act of 1973, as amended, 29 USC § 794, the Americans with Disabilities Act of 1990, as amended, 42 USC § 12101 et seq., the Architectural Barriers Act of 1968, as amended, 42 USC § 4151 et seq., and Federal transit law at 49 USC § 5332, the Contractor agrees that it will not discriminate against individuals on the basis of disability. In addition, the Contractor agrees to comply with any implementing requirements FTA may issue.
- C. Equal Employment Opportunity Requirements for Construction Activities. In addition to the foregoing, when undertaking “construction” as recognized by the DOL, the Contractor agrees to comply, and assures the compliance of each subcontractor, with:
- 1) DOL regulations, *Office of Federal Contract Compliance Programs, Equal Employment Opportunity, Department of Labor, 41 CFR chapter 60; and*
 - 2) Executive Order No. 11246, *Equal Employment Opportunity*, as amended by Executive Order Nos. 11375 and 13672, 42 USC § 2000e note; and
 - 3) Notice of Requirement for Affirmative Action to Ensure Equal Employment Opportunity (Executive Order 11246)
 - a) The Contractor's attention is called to the “Equal Opportunity Clause” and the “Standard Federal Equal Employment Specifications” set forth herein.
 - b) The goals and timetables for minority and female participation, expressed in percentage terms for the Contractor's aggregate workforce in each trade on all construction work in the covered area, are as follows:

Goal for Minority Participation Each Trade	Goal for Female Participation Each Trade
2.8%	6.9%

EXHIBIT A

FEDERAL TERMS & CONDITIONS

These goals are applicable to all the Contractor's construction work (whether or not it is Federal or federally assisted) performed in the covered area. If the Contractor performs construction work in a geographical area located outside of the covered area, it shall apply the goals established for such geographical area where the work is actually performed. With regard to this second area, the Contractor also is subject to the goals for both its federally involved and non-federally involved construction.

The Contractor's compliance with the Executive Order and the regulations in 41 CFR Part 60-4 shall be based on its implementation of the Equal Opportunity Clause, specific affirmative action obligations required by the specifications set forth in 41 CFR 60-4.3(a), and its efforts to meet the goals. The hours of minority and female employment and training must be substantially uniform throughout the length of the Contract, and in each trade, and the Contractor shall make a good faith effort to employ minorities and women evenly on each of its projects. The transfer of minority or female employees or trainees from Contractor to Contractor or from project to project for the sole purpose of meeting the Contractor's goals shall be a violation of the Contract, the Executive Order, and the regulations in 41 CFR Part 60-4. Compliance with the goals will be measured against the total work hours performed.

- c) The Contractor shall provide written notification to the Director of the Office of Federal Contract Compliance Programs within ten (10) working days of award of any construction subcontract in excess of \$10,000 at any tier for construction work under the Contract resulting from this solicitation. The notification shall list the name, address, and telephone number of the subcontractor; employer identification number of the subcontractor; estimated dollar amount of the subcontract; estimated starting and completion dates of the subcontract; and the geographical area in which the subcontract is to be performed.
- d) As used in this notice, and in the Contract resulting from this solicitation, the "covered area" is Spokane County, City of Spokane, State of Washington.

25. BREACHES AND DISPUTE RESOLUTION

- A. Applicability. All contracts exceeding the SAT.
- B. Disputes arising in the performance of this Contract which are not resolved by agreement of the parties shall be decided in writing by STA's Contract Compliance Specialist. This decision shall be final and conclusive, unless within ten (10) days from the date of receipt of its copy, Contractor mails or otherwise furnishes a written appeal to STA's CEO. In connection with such appeal, Contractor shall be afforded an opportunity to be heard and to offer evidence in support of its position. The decision of STA's CEO shall be binding upon Contractor and Contractor shall abide by the decision. FTA has a vested interest in the settlement of any violation of Federal law including the False Claims Act, 31 USC § 3729.
- C. Performance During Dispute. Unless otherwise directed in writing by STA, Contractor shall continue performance under this Contract while matters in dispute are being resolved.
- D. Claims for Damages. Should either Party suffer injury or damage to person or property because of any act or omission of the other Party or of any of its employees, agents, or others for whose acts it is legally liable, a claim for damages therefore shall be made in writing to such other Party within ten (10) days after the first observance of such injury or damage.
- E. Remedies. Unless this Contract provides otherwise, all claims, counterclaims, disputes, and other matters in question between STA and the Contractor arising out of or relating to this Contract or its breach will be decided by arbitration if the parties mutually agree, or in a court of competent jurisdiction within the State of Washington.

EXHIBIT A

FEDERAL TERMS & CONDITIONS

- F. Rights and Remedies. Duties and obligations imposed by the Contract and the rights and remedies available thereunder shall be in addition to and not a limitation of any duties, obligations, rights, and remedies otherwise imposed or available by law. No action or failure to act by STA or Contractor shall constitute a waiver of any right or duty afforded any of them under the Contract, nor shall any such action or failure to act constitute an approval of or acquiescence in any breach thereunder, except as may be specifically agreed in writing.

26. PATENT AND DATA RIGHTS

- A. Applicability. Contracts involving experimental, developmental, or research work.

- B. Patent Rights.

- 1) General. STA and the Contractor agree:

- a) Depending on the nature of the project, the Federal Government may acquire patent rights when STA or Contractor produces a patented or patentable invention, improvement, or discovery.
- b) The Federal Government's rights arise when the patent or patentable information is conceived under the project or reduced to practice under the project.
- c) When a patent is issued or patented information becomes available, the Contractor agrees to:
 - (1) Notify STA immediately, and
 - (2) Provide STA a detailed report satisfactory to FTA.

- 2) Federal Rights. The Contractor agrees that:

- a) Its rights and responsibilities, and the rights and responsibilities of each subcontractor, in that federally funded invention, improvement or discovery will be determined as provided by applicable Federal laws, regulations and guidance, including any waiver thereof; and
- b) Unless the Federal Government determines otherwise in writing, irrespective of the Contractor's status or the status of any subcontractor as a large business, a small business, a State government, a State instrumentality, a local government, an Indian tribe, a nonprofit organization, an institution of higher education or an individual, the Contractor agrees to transmit the Federal Government's patent rights to FTA as specified in:
 - (1) 35 USC § 200 *et seq.*; and
 - (2) US Department of Commerce regulations, *Rights to Inventions Made by Nonprofit Organizations and Small Business Firms Under Government Grants, Contracts and Cooperative Agreements*, 37 CFR Part 401.

- 3) License Fees and Royalties. As permitted by 2 CFR 200, Appendix II (F):

- a) License fees and royalties for patents, patent applications and inventions derived from the project are program income; and
- b) The Contractor has no obligation to the Federal Government with respect to those license fees or royalties; except:
 - (1) For compliance with 35 USC § 200 *et seq.*, which applies to patent rights developed under a federally funded research-type projects; and

EXHIBIT A

FEDERAL TERMS & CONDITIONS

(2) As FTA determines otherwise in writing.

C. Rights in Data and Copyrights.

- 1) Definition of “Subject Data” means recorded information:
 - a) Copyright. Whether or not copyrighted; and
 - b) Delivery. That is delivered or specified to be delivered under the Contract.
- 2) Examples of Subject Data include, but are not limited to:
 - a) Computer software, standards, specifications, engineering drawings and associated lists, process sheets, manuals, technical reports, catalog item identifications, and related information; but
 - b) Do not include financial reports, cost analyses or other similar information used for project administration.
- 3) General Federal Restrictions. The following restrictions apply to all Subject Data first produced in the performance of STA’s project supported by the Contract:
 - a) Prohibitions. The Contractor may not:
 - (1) Publish or reproduce any Subject Data in whole or in part, or in any manner or form; or
 - (2) Permit others to do so; but
 - b) Exceptions. The prohibitions of Rights in Data and Copyrights do not apply to:
 - (1) Publications or reproductions for STA’s own internal use;
 - (2) An institution of higher learning;
 - (3) The portion of Subject Data that the Federal Government has previously released or approved for release to the public; or
 - (4) The portion of data that has the Federal Government’s prior written consent for release.
- 4) Federal Rights in Data and Copyrights. The Contractor agrees that:
 - a) License Rights. The Contractor must provide a license to its Subject Data to the Federal Government, which license is royalty-free, non-exclusive, and irrevocable.
 - b) Uses. The Federal Government’s license must permit the Federal Government to take the following actions provided those actions are taken for Federal Government purposes:
 - (1) Reproduce the Subject Data;
 - (2) Publish the Subject Data;
 - (3) Otherwise use the Subject Data; and
 - (4) Permit other entities or individuals to use the Subject Data.
- 5) Special Federal Rights in Data for Research, Development, Demonstration, Deployment, and Special Studies Projects. In general, FTA’s purpose in providing Federal funds for a research, development, demonstration, deployment, or special studies Project is to increase transportation knowledge, rather than limit the benefits of the project to STA and its third-party participants. Therefore, the Contractor agrees that:

EXHIBIT A

FEDERAL TERMS & CONDITIONS

- a) Publicly Available Report. When the project is completed, it must provide a project report that FTA may publish or make available for publication on the Internet; and
 - b) Other Reports. It must provide other reports pertaining to the project that FTA may request.
 - c) Availability of Subject Data. FTA may make available to any FTA recipient or any of its third-party participants at any tier of the project, either FTA's copyright license to the Subject Data or a copy of the Subject Data, except as the Federal Government determines otherwise in writing.
 - d) Identification of Information. It must identify clearly any specific confidential, privileged, or proprietary information submitted to FTA.
 - e) Incomplete Project. If the project is not completed for any reason whatsoever, all data developed under the project becomes Subject Data and must be delivered as the Federal Government may direct; but
 - f) Exception. Rights in Data and Copyrights Section 27.C does not apply to an adaptation of automatic data processing equipment or program that is both:
 - (1) For STA's use, and
 - (2) Acquired with FTA capital program funding.
- 6) License Fees and Royalties. As permitted by 49 CFR Parts 18 and 19:
- a) License fees and royalties for copyrighted material or trademarks derived from project are program income; and
 - b) The Contractor has no obligation to the Federal Government with respect to those license fees or royalties, except:
 - (1) For compliance with 35 USC § 200 *et seq.*, which applies to patent rights developed under a federally funded research-type project; and
 - (2) As FTA determines otherwise in writing.
- 7) Hold Harmless. Upon request by the Federal Government, the Contractor agrees that:
- a) Violation by Contractor.
 - (1) If it willfully or intentionally violates any proprietary rights, copyrights or right of privacy, and
 - (2) Its violation occurs from any of the following uses of Project data: publication, translation, reproduction, delivery, use or disposition, then
 - (3) It will indemnify, save, and hold harmless against any liability, including costs and expenses of:
 - (a) The Federal Government's officers acting within the scope of their official duties;
 - (b) The Federal Government's employees acting within the scope of their official duties; and
 - (c) Federal Government's agents acting within the scope of their official duties; but
 - (4) Exceptions. The Contractor will not be required to indemnify the Federal Government for any liability described in Rights in Data and Copyrights if:

EXHIBIT A

FEDERAL TERMS & CONDITIONS

- (a) Violation by Federal Officers, Employees or Agents. The violation is caused by the wrongful acts of Federal employees or agents; or
- (b) State law. If indemnification is prohibited or limited by applicable State law.
- 8) Restrictions on Access to Patent Rights. Nothing in this Rights in Data and Copyrights section pertaining to rights in data either:
- Implies a license to the Federal Government under any patent; or
 - May be construed to affect the scope of any license or other right otherwise granted to the Federal Government under any patent.
- 9) Data Developed Without Federal Funding or Support. The Contractor understands and agrees that in certain circumstances it may need to provide data developed without any Federal funding or support to FTA. Nevertheless:
- Protections. Rights in Data and Copyrights Sections 27.C.1) through 27.C.4) generally do not apply to data developed without Federal funding, even though that data may have been used in connection with the project; and
 - Identification of Information. The Contractor understands and agrees that the Federal Government will not be able to protect data developed without Federal funding from unauthorized disclosure unless that data is clearly marked “Proprietary” or “Confidential”.
- 10) Requirements to Release Data. The Contractor understands and agrees that the Federal Government may be required to release project data and information STA submits to the Federal Government as required by:
- The Freedom of Information Act, 5 USC § 552;
 - Another applicable Federal law requiring access to project records;
 - DOT regulations, *Uniform Administrative Requirements, Cost Principles, and Audit Requirements for Federal Awards*, specifically 2 CFR § 200.211 or
 - Other applicable Federal regulations and guidance pertaining to access to project records.

27. TRANSIT EMPLOYEE PROTECTIVE PROVISIONS

- A. Applicability. All contracts.
- B. Public Transportation Employee Protective Arrangements. The Contractor agrees that 49 USC § 5333(b) requires employee protective arrangements to be in place as a condition of award of FTA assistance made available or appropriated for FTA programs involving public transportation operations. DOL recognizes the following categories of arrangements:
- 1) DOL Certification. When the Contract involves public transportation operations and is financed with funding made available or appropriated for 49 USC §§ 5307, 5309, 5312, 5337 or 5339, as amended by MAP-21, or former 49 USC §§ 5308, 5309, 5312 or other provisions of law as required by the Federal Government, DOL must provide a Certification of employee protective arrangements before FTA may provide financial assistance for the Contract. Therefore, the Contractor understands and agrees, and assures that Contractor, and any subcontractors, providing public transportation operations will agree, that:

EXHIBIT A

FEDERAL TERMS & CONDITIONS

- a) It must carry out the Contract as provided in its DOL Certification, which contains the terms and conditions that DOL has determined to be fair and equitable to protect the interests of any employees affected by the Contract;
 - b) It must comply with 49 USC § 5333(b), and any future amendments thereto;
 - c) It will follow the DOL guidelines, *Guidelines, Section 5333(b), Federal Transit Law, 29 CFR Part 215*, except as DOL determines otherwise in writing;
 - d) It must comply with the terms and conditions of the DOL certification of public transportation employee protective arrangements for the project, which certification is dated as identified on the Contract, including:
 - (1) Alternative comparable arrangements DOL has specified for the project;
 - (2) Any revisions DOL has specified for the project; or
 - (3) Both;
 - e) It must comply with the following documents and provisions incorporated by reference in and made part of the Contract for the project:
 - (1) The DOL certification of public transportation employee protective arrangements for the project, which certification is dated as identified on the Contract;
 - (2) The documents cited in that DOL certification for the project;
 - (3) Any alternative comparable arrangements that DOL has specified for the project; and
 - (4) Any revisions that DOL has specified for the project.
- 2) Special Warranty. When the project involves public transportation operations and is financed with funding made available or appropriated for 49 USC § 5311, as amended by MAP-21, for former 49 USC § 5311 in effect in FY 2012, or a previous fiscal year, or for section 3038 of TEA-21, as amended by section 3039 of SAFETEA-LU, DOL will provide a Special Warranty for those projects, including projects under the Tribal Transit Program. Therefore, the Contractor understands and agrees, and assures that it, and any subcontractors, providing public transportation operations will agree, that:
- a) It must comply with Federal transit laws, specifically 49 USC § 5333(b);
 - b) Follow the DOL guidelines, *Guidelines, Section 5333(b), Federal Transit Law, 29 CFR Part 215*, except as DOL determines otherwise in writing;
 - c) It will comply with the DOL Special Warranty for its project that is most current on the date when it executed the Contract, and documents cited therein, including:
 - (1) Any alternative comparable arrangements DOL has specified for the project;
 - (2) Any revisions DOL has specified for the project; or
 - (3) Both;
 - d) It will comply with the following documents and provisions incorporated by reference in and made part of the Contract:
 - (1) The DOL Special Warranty for its project;
 - (2) Documents cited in that Special Warranty;
 - (3) Alternative comparable arrangements DOL specifies for the project; and

EXHIBIT A

FEDERAL TERMS & CONDITIONS

(4) Any revisions that DOL has specified for the project.

- 3) Special Arrangements for 49 USC § 5310 Projects. The Contractor understands and agrees, and assures that any subcontractors providing public transportation operations will agree, that although pursuant to 49 USC § 5310, and former 49 USC §§ 5310 or 5317, FTA has determined that it was not “necessary or appropriate” to apply the conditions of 49 USC § 5333(b) to subrecipients participating in the program to provide public transportation for seniors (elderly individuals) and individuals with disabilities, FTA reserves the right to make the following exceptions:
- a) FTA will make case-by-case determinations of the applicability of 49 USC § 5333(b) for all transfers of funding authorized under title 23, United States Code (flex funds); and
 - b) FTA reserves the right to make other exceptions as it deems appropriate.

28. DISADVANTAGED BUSINESS ENTERPRISES (DBE)

- A. Applicability. All contracts.
- B. This Contract is subject to the requirements of Title 49, CFR Part 26, *Participation by Disadvantaged Business Enterprises in Department of Transportation Financial Assistance Programs*. The national goal for participation of Disadvantaged Business Enterprises (DBE) is ten percent (10%). STA’s overall goal for DBE participation may be found at <https://www.spokanetransit.com/about-sta/disadvantaged-business-enterprise-program>.
- C. The Contractor shall not discriminate on the basis of race, color, national origin, or sex in the performance of this Contract. The Contractor shall carry out applicable requirements of 49 CFR Part 26 in the award and administration of this Contract. Failure by the Contractor to carry out these requirements is a material breach of this Contract, which may result in the termination of this Contract or such other remedy as STA deems appropriate. Each subcontract the Contractor signs with a subcontractor must include the assurance in this paragraph (see 49 CFR 26.13(b)).
- D. If a separate contract goal has been established, Contractor is required to document sufficient DBE participation to meet these goals or, alternatively, document adequate good faith efforts to do so, as provided for in 49 CFR 26.53.
- E. If no separate Contract goal has been established, the successful Contractor will be required to report its DBE participation obtained through race-neutral means throughout the period of performance.
- F. The Contractor is required to pay its subcontractors performing work related to this Contract for satisfactory performance of that work no later than thirty (30) days after the Contractor’s receipt of payment for that work from STA. In addition, the Contractor may not hold retainage from its subcontractors.
- G. The Contractor must promptly notify STA whenever a DBE subcontractor performing work related to this Contract is terminated or fails to complete its work, and must make good faith efforts to engage another DBE subcontractor to perform at least the same amount of work. The Contractor may not terminate any DBE subcontractor and perform that work through its own forces or those of an affiliate without prior written consent of STA.

29. PROMPT PAYMENT

- A. Applicability. All contracts.

EXHIBIT A

FEDERAL TERMS & CONDITIONS

- B. The Contractor agrees to pay each subcontractor under this Contract for satisfactory performance of its contract no later than thirty (30) days from the receipt of each payment the Contractor receives from STA. Any delay or postponement of payment from the above referenced time frame may occur only for good cause following written approval of STA. This clause applies to both DBE and non-DBE subcontracts.

30. INCORPORATION OF FEDERAL TRANSIT ADMINISTRATION (FTA) TERMS

- A. Applicability. All contracts.
- B. The provisions herein include, in part, certain Standard Terms & Conditions required by DOT, whether or not expressly stated in these contract provisions. All DOT-required contractual provisions, as stated in FTA Circular 4220.1F and the Master Agreement, are hereby incorporated by reference. Anything to the contrary herein notwithstanding, all FTA mandated terms shall be deemed to control in the event of a conflict with other provisions contained in this Contract. The Contractor shall not perform any act, fail to perform any act, or refuse to comply with any request that would cause STA to be in violation of FTA terms and conditions.

31. DRUG & ALCOHOL ABUSE AND TESTING

- A. Applicability. Operational service contracts performing safety-sensitive functions as defined under 49 CFR 655.4.
- B. The Contractor agrees to comply with the following Federal substance abuse regulations:
- 1) Drug-Free Workplace. DOT regulations, *Drug-Free Workplace Requirements (Grants)*, 49 CFR Part 32, that implements the Drug-Free Workplace Act of 1988 as amended, 41 USC §§ 8103 *et seq.*; and
 - 2) 49 CFR Part 655, Alcohol Misuse and Prohibited Drug Use in Transit Operations. FTA Regulations, *Prevention of Alcohol Misuse and Prohibited Drug Use in Transit Operations*, 49 USC 5331, as amended by MAP-21, 49 CFR Part 40, 49 USC chapter 53, 49 CFR Part 655, to the extent applicable.

32. OTHER FEDERAL REQUIREMENTS:

- A. Full and Open Competition. In accordance with 49 USC § 5325(h) all procurement transactions shall be conducted in a manner that provides full and open competition.
- B. Prohibition Against Exclusionary or Discriminatory Specifications. Apart from inconsistent requirements imposed by Federal statute or regulations, the Contractor shall comply with the requirements of 49 USC 5323(h)(2) by refraining from using any FTA assistance to support procurements using exclusionary or discriminatory specifications.
- C. Conformance with ITS National Architecture. Contractor shall conform, to the extent applicable, to the National Intelligent Transportation Standards architecture as required by SAFETEA-LU Section 5307(c), 23 USC Section 512 note and follow the provisions of FTA Notice, *FTA National Architecture Policy on Transit Projects*, 66 Fed. Reg. 1455 *et seq.*, January 8, 2001, and any other implementing directives FTA may issue at a later date, except to the extent FTA determines otherwise in writing.
- D. Access Requirements for Persons with Disabilities. Contractor shall comply with 49 USC 5301(d), stating Federal policy that the elderly and persons with disabilities have the same rights as other persons to use mass transportation services and facilities and that special efforts shall be made in planning and designing those services and facilities to implement that policy. Contractor

EXHIBIT A

FEDERAL TERMS & CONDITIONS

shall also comply with all applicable requirements of Sec. 504 of the Rehabilitation Act (1973), as amended, 29 USC 794, which prohibits discrimination on the basis of handicaps, and the Americans with Disabilities Act of 1990 (ADA), as amended, 42 USC 12101 *et seq.*, which requires that accessible facilities and services be made available to persons with disabilities, including any subsequent amendments thereto.

- E. Notification of Federal Participation. To the extent required by law, in the announcement of any third-party contract award for goods and services (including construction services) having an aggregate value of \$500,000 or more, Contractor shall specify the amount of Federal assistance to be used in financing that acquisition of goods and services and express that amount of Federal assistance as a percentage of the total cost of the third-party contract.
- F. Interest of Members or Delegates to Congress. No members of, or delegates to, the US Congress shall be admitted to any share or part of this Contract nor to any benefit arising therefrom.
- G. Ineligible Contractors and Subcontractors. Any name appearing upon the Comptroller General's list of ineligible contractors for federally assisted contracts shall be ineligible to act as a subcontractor for Contractor pursuant to this Contract. If Contractor is on the Comptroller General's list of ineligible contractors for federally financed or assisted construction, STA shall cancel, terminate, or suspend this Contract.
- H. Real Property. Any contract entered into shall contain the following provisions:
- 1) Contractor shall at all times comply with all applicable statutes and DOT regulations, policies, procedures, and directives governing the acquisition, use and disposal of real property, including, but not limited to, 49 CFR 18.31-18.34, 49 CFR 19.30-19.37, 49 CFR Part 24, 49 CFR 5326 as amended by MAP-21, 49 CFR Part 18 or 19, 49 USC 5334, applicable FTA Circular 5010, and the Master Agreement between STA and FTA, as they may be amended or promulgated during the term of this Contract.
 - 2) Contractor's failure to so comply shall constitute a material breach of this Contract.
- I. Environmental Justice. Except as the Federal Government determines otherwise in writing, the Contractor agrees to promote environmental justice by following:
- 1) Executive Order No. 12898, *Federal Actions to Address Environmental Justice in Minority Populations and Low-Income Populations*, February 11, 1994, 42 USC § 4321 note, as well as facilitating compliance with that Executive Order; and
 - 2) DOT Order 5610.2, *Department of Transportation Actions to Address Environmental Justice in Minority Populations and Low-Income Populations*, 62 Fed. Reg. 18377, April 15, 1997; and
 - 3) The most recent and applicable edition of FTA Circular 4703.1, *Environmental Justice Policy Guidance for Federal Transit Administration Recipients*, August 15, 2012, to the extent consistent with applicable Federal laws, regulations, and guidance.
- J. Environmental Protections. Compliance is required with any applicable Federal laws imposing environmental and resource conservation requirements for the project. Some, but not all, of the major Federal laws that may affect the project include:
- 1) the National Environmental Policy Act of 1969;
 - 2) the Clean Air Act;
 - 3) the Resource Conservation and Recovery Act;

EXHIBIT A

FEDERAL TERMS & CONDITIONS

- 4) the comprehensive Environmental Response, Compensation and Liability Act; and
- 5) environmental provisions with Title 23 USC, and 49 USC chapter 53.

The EPA, FHWA and other federal agencies may issue other federal regulations and directives that may affect the project. Compliance is required with any applicable Federal laws and regulations in effect now or that become effective in the future.

- K. Geographic Information and Related Spatial Data. Any Contract activities involving spatial data or geographic information systems activities financed with Federal assistance are required to be consistent with the National Spatial Data Infrastructure promulgated by the Federal Geographic Data Committee, except to the extent that FTA determines otherwise in writing.
- L. Geographic Preference. All project activities must be advertised without geographic preference, (except in A/E under certain circumstances, preference for hiring veterans on transit construction projects and geographic-based hiring preferences as proposes to be amended in 2 CFR Part 1201).
- M. Organizational Conflicts of Interest. The Contractor agrees that it will not enter into a procurement that involves a real or apparent organizational conflict of interest described as follows:
 - 1) When It Occurs. An organizational conflict of interest occurs when the project work, without appropriate restrictions on certain future activities, results in an unfair competitive advantage:
 - a) To that third-party or another third-party performing the project work, and
 - b) That impairs that third-party's objectivity in performing the project work, or
 - c) An organizational conflict of interest may involve other situations resulting in fundamentally unfair competitive conditions.
 - 2) Disclosure Requirements. Consistent with FTA policies, the Contractor must disclose to STA, and each of its subcontractors must disclose to the Contractor:
 - a) Any instances of organizational conflict of interest, or
 - b) Violations of federal criminal law, involving fraud, bribery or gratuity violations potentially affecting the federal award.
 - 3) Failure to Disclose. Failure to make required disclosures can result in remedies for noncompliance, including debarment or suspension.
- N. Veterans Preference. As provided by 49 USC § 5325(k), to the extent practicable, the Contractor agrees and assures that each of its subcontractors:
 - 1) Will give a hiring preference to veterans, as defined in 5 USC § 2108, who have the skills and abilities required to perform construction work required under a third-party contract in connection with a capital project supported with federal assistance appropriated or made available for 49 USC chapter 53; and
 - 2) Will not require an employer to give a preference to any veteran over any equally qualified applicant who is a member of any racial or ethnic minority, female, an individual with a disability, or a former employee.
- O. Safe Operation of Motor Vehicles.
 - 1) Seat Belt Use. The Contractor agrees to implement Executive Order No. 13043, *Increasing Seat Belt Use in the United States*, April 16, 1997, 23 USC § 402 note, (62 Fed. Reg. 19217), by:

EXHIBIT A

FEDERAL TERMS & CONDITIONS

- a) Adopting and promoting on-the-job seat belt use policies and programs for its employees and other personnel that operate company-owned vehicles, company-rented vehicles, or personally operated vehicles: and
 - b) Including a “Seat Belt Use” provision in each third-party agreement related to the Contract.
- 2) Distracted Driving, Including Text Messaging While Driving. The Contractor agrees to comply with:
- a) Executive Order No. 13513, *Federal Leadership on Reducing Text Messaging While Driving*, October 1, 2009, 23 USC § 402 note, (74 Fed. Reg. 51225);
 - b) DOT Order 3902.10, *Text Messaging While Driving*, December 30, 2009: and
 - c) The following DOT Special Provision pertaining to Distracted Driving:
 - (1) Safety. The Contractor agrees to adopt and enforce workplace safety policies to decrease crashes caused by distracted drivers, including policies to ban text messaging while using an electronic device supplied by an employer, and driving a vehicle the driver owns or rents, a vehicle STA owns, leases or rents, or a privately-owned vehicle when on official business in connection with the Contract, or when performing any work for or on behalf of the Contract.
 - (2) Contractor Size. The Contractor agrees to conduct workplace safety initiatives in a manner commensurate with its size, such as establishing new rules and programs to prohibit text messaging while driving, re-evaluating the existing programs to prohibit text messaging while driving, and providing education, awareness, and other outreach to employees about the safety risks associated with texting while driving.
 - (3) Extension of Provision. The Contractor agrees to include this Section in all third-party agreements and encourage any third-party to comply with this section, and include this Section 33.O in each third-party agreement at each tier supported with federal assistance.
- P. Notification of Dispute, Breach, Default and Litigation. Contractor, its subconsultants and subcontractors, of any tier, shall promptly notify (through the Contractor) STA in writing of any current or prospective legal matter that may impact any contract that is considered a “covered transaction” in accordance with 2 CFR §§ 180.220 and 1200.220. The Contractor, its subconsultants and subcontractors, shall include the requirements of this section in all subcontracts with third parties at every tier.
- Q. Prohibition on Certain Telecommunications and Video Surveillance Services or Equipment.
- 1) Contractors and its subconsultants and subcontractors of every tier are prohibited from expending funds to:
 - a) Procure or obtain;
 - b) Extend or renew a contract to procure or obtain; or
 - c) Enter into a contract or extend or renew a contract to procure or obtain equipment, services or systems that uses "Covered Telecommunications Equipment or Services" as a substantial or essential component of any system, or as critical technology as part of any system. As described in Public Law 115-232, section 889, Covered Telecommunications Equipment is telecommunications equipment produced by Huawei Technologies Company or ZTE Corporation (or any subsidiary or affiliate of such entities.

EXHIBIT A

FEDERAL TERMS & CONDITIONS

- (1) For the purpose of public safety, security of government facilities, physical security surveillance of critical infrastructure, and other national security purposes, video surveillance and telecommunications equipment produced by Hytera Communications Corporation, Hangzhou Hikvision Digital Technology Company, or Dahua Technology Company (or any subsidiary or affiliate of such entities).
- (2) Telecommunications or video surveillance services provided by such entities or using such equipment.
- (3) Telecommunications or video surveillance equipment or services produced or provided by an entity that the Secretary of Defense, in consultation with the Director of the National Intelligence or the Director of the Federal Bureau of Investigation, reasonably believes to be an entity owned or controlled by, or otherwise connected to, the government of a covered foreign country.

**Agenda Sheet for City Council:****Committee:** PIES **Date:** 07/15/2024**Committee Agenda type:** Consent**Date Rec'd**

7/15/2024

Clerk's File #

OPR 2024-0614

Cross Ref #**Project #**

IPWQ 6154-24

Council Meeting Date: 08/12/2024**Submitting Dept**

WASTEWATER MANAGEMENT

Bid #**Contact Name/Phone**

KYLE 625.4647

Requisition #**Contact E-Mail**

KARRINGTON@SPOKANECITY.ORG

Agenda Item Type

Contract Item

Council Sponsor(s)

BWILKERSON JBINGLE KKLITZKE

Agenda Item Name

4320 HVAC PREVENTATIVE MAINTENANCE AND REPAIR SERVICE TO ACI

Agenda Wording

Consent to award, IPWQ 6154-24 HVAC PM and Repair Services to ACI Northwest, Inc. for a three (3) year period (with two (2) one-year renewal options). This contract is scheduled to begin August 1, 2024, and terminating on July 31, 2027.

Summary (Background)

IPWQ 6154-24 was issued to enable us to procure necessary preventative maintenance and on call repair service of our HVAC equipment.

Lease? NO Grant related? NO Public Works? YES

Fiscal Impact

Approved in Current Year Budget? YES

Total Cost \$ 71,650.00

Current Year Cost \$ 71,650.00

Subsequent Year(s) Cost \$ 71,650.00

Narrative

Operating need from our department budget.

Amount**Budget Account**

Expense \$ 71,650.00 # 4320.43106.35148.54802

Expense \$ 71,650.00 # 4320.43106.35148.54802

Expense \$ 71,650.00 # 4320.43106.35148.54802

Select \$ #

\$ #

\$ #



Continuation of Wording, Summary, Approvals, and Distribution

Agenda Wording

Summary (Background)

Approvals

Dept Head

ARRINGTON, KYLE

Division Director

MILLER, KATHERINE E

Accounting Manager

ALBIN-MOORE, ANGELA

Legal

HARRINGTON,

For the Mayor

PICCOLO, MIKE

Additional Approvals

Distribution List

Mike Jones mjones@acinw.com

hbarnhart@spokanecity.org

kkeck@spokanecity.org

mmurray@spokanecity.org

Tax & Licenses

tlester@spokanecity.org

rpwrfaccounting@spokanecity.org

Committee Agenda Sheet

Public Infrastructure, Environment & Sustainability Committee

Committee Date	7/15/24
Submitting Department	Wastewater Management/RPWRP
Contact Name	Kyle Arrington
Contact Email & Phone	karrington@spokanecity.org
Council Sponsor(s)	CP Wilkerson, CM Bingle, CM Klitzke
Select Agenda Item Type	<input checked="" type="checkbox"/> Consent <input type="checkbox"/> Discussion Time Requested:
Agenda Item Name	Consent to award three (3) year contract to supply HVAC Preventative Maintenance and on call Repair Services to ACI Northwest, Inc.
Proposed Council Action	<input checked="" type="checkbox"/> Approval to proceed to Legislative Agenda <input type="checkbox"/> Information Only
Summary (Background)	<p>IPWQ 6154-24 was issued to enable us to procure necessary preventative maintenance and on call repair service of our HVAC equipment.</p> <p>*use the Fiscal Impact box below for relevant financial information</p> <p>The contract shall be with ACI Northwest, Inc. for a three (3) year period (with two (2) one-year renewal options). This contract is scheduled to begin August 1, 2024, and terminating on July 30, 2029, not to exceed 5 years.</p>
<p>Fiscal Impact</p> <p>Approved in current year budget? <input checked="" type="checkbox"/> Yes <input type="checkbox"/> No <input type="checkbox"/> N/A</p> <p>Total Cost: <u>\$71,650.00</u></p> <p style="padding-left: 20px;">Current year cost: \$71,650.00</p> <p style="padding-left: 20px;">Subsequent year(s) cost: \$71,650.00</p> <p>Narrative: <u>Operating need from our department budget.</u></p> <p>Funding Source <input type="checkbox"/> One-time <input checked="" type="checkbox"/> Recurring <input type="checkbox"/> N/A</p> <p>Specify funding source: Program revenue</p> <p>Is this funding source sustainable for future years, months, etc? Yes, Operating Budget</p> <p>Expense Occurrence <input type="checkbox"/> One-time <input checked="" type="checkbox"/> Recurring <input type="checkbox"/> N/A</p> <p>Other budget impacts: (revenue generating, match requirements, etc.)</p>	
<p>Operations Impacts (If N/A, please give a brief description as to why)</p> <ul style="list-style-type: none"> • What impacts would the proposal have on historically excluded communities? Public works services and projects are designed to serve all citizens and businesses. We strive to offer a consistent level of service to all, to distribute public investment throughout the community and to respond to gaps in services identified in various City plans. • How will data be collected, analyzed, and reported concerning the effect of the program/policy by racial, ethnic, gender identity, national origin, income level, disability, sexual orientation, or other existing disparities? N/A • How will data be collected regarding the effectiveness of this program, policy, or product to ensure it is the right solution? 	

Public Works follows the City's established procurement and public works bidding regulations and policies to bring items forward, and then uses contract management best practices to ensure desired outcomes and regulatory compliance.

- Describe how this proposal aligns with current City Policies, including the Comprehensive Plan, Sustainability Action Plan, Capital Improvement Program, Neighborhood Master Plans, Council Resolutions, and others?

This work is consistent with annual budget strategies to limit costs and approved projects in the 6-year CIP.

Council Subcommittee Review

- Please provide a summary of council subcommittee review. If not reviewed by a council subcommittee, please explain why not.



City of Spokane
**PREVENTATIVE MAINTENANCE
AGREEMENT**

This Agreement is made and entered into by and between the **CITY OF SPOKANE** as (“City”), a Washington municipal corporation, and **ACI NORTHWEST, INC.**, whose address is 6600 North Government Way, Dalton Gardens, Idaho 83815 as (“Contractor”), individually hereafter referenced as a “party”, and together as the “parties”.

WHEREAS, the purpose of this Agreement is to provide HVAC Preventative Maintenance and On Call Repair Services at the Riverside Park Water Reclamation Facility; and

WHEREAS, the Contractor was selected from IPWQ 6154-24.

NOW, THEREFORE, in consideration of the terms, conditions, covenants and performance of the Scope of Work contained herein, the City and Contractor mutually agree as follows:

1. TERM OF AGREEMENT.

The term of this Agreement begins on August 1, 2024, and ends on July 31, 2027, unless amended by written agreement or terminated earlier under the provisions. . The Agreement may be renewed for two (2) additional one-year contract periods, subject to mutual agreement.

2. TIME OF BEGINNING AND COMPLETION.

The Contractor shall begin the work outlined in the “Scope of Work” (“Work”) on the beginning date, above. The City will acknowledge in writing when the Work is complete. Time limits established under this Agreement shall not be extended because of delays for which the Contractor is responsible, but may be extended by the City, in writing, for the City’s convenience or conditions beyond the Contractor’s control.

3. SCOPE OF WORK.

The Contractor’s General Scope of Work for this Agreement is described in the City’s IPWQ and the Contractor’s Response which is attached hereto as Exhibit C and made a part of this Agreement. In the event of a conflict or discrepancy in the Agreement documents, this City Agreement controls.

The Contractor shall provide HVAC Preventative Maintenance and On Call Repair Services at the Riverside Park Water Reclamation Facility.

The Work is subject to City review and approval. The Contractor shall confer with the City periodically and prepare and present information and materials (e.g. detailed outline of completed Work) requested by the City to determine the adequacy of the Work or Contractor’s progress.

4. COMPENSATION / PAYMENT.

Total annual compensation for Contractor’s services under this Agreement shall be a

maximum amount not to exceed **SEVENTY-ONE THOUSAND SIX HUNDRED FIFTY AND NO/100 DOLLARS (\$71,650.00)**, plus applicable tax, per year, for everything furnished and done under this Agreement. This is an optional use contract. Services by the Contractor are provided on an as-needed basis upon request in accordance with the terms of the Contract documents. Only the services requested, received and accepted will be paid for by the City.

The Company shall submit its applications for payment to Riverside Park Water Reclamation Facility, Administration Office, 4401 North Aubrey L. White Parkway, Spokane, Washington 99205. All invoices should include the City Clerk's File No. "OPR XXXX-XXXX" and an approved L & I Intent to Pay Prevailing Wage number. The final invoice should include an approved Affidavit of Wages Paid number. Payment will not be made without this documentation included on the invoice. **Payment will be made via direct deposit/ACH** within thirty (30) days after receipt of the Company's application except as provided by state law. If the City objects to all or any portion of the invoice, it shall notify the Company and reserves the right to only pay that portion of the invoice not in dispute. In that event, the parties shall immediately make every effort to settle the disputed amount.

5. TAXES, FEES AND LICENSES.

- A. Contractor shall pay and maintain in current status, all necessary licenses, fees, assessments, permit charges, etc. necessary to conduct the work included under this Agreement. It is the Contractor's sole responsibility to monitor and determine changes or the enactment of any subsequent requirements for said fees, assessments, or changes and to immediately comply.
- B. The cost of any permits, licenses, fees, etc. arising as a result of the projects included in this Agreement shall be included in the project budgets.

6. PREVENTATIVE MAINTENANCE.

The following Preventative Maintenance requirements apply to the Work under this Agreement:

- A. The Contractor shall pay state prevailing wages. The Contractor and all subcontractors will submit a "Statement of Intent to Pay Prevailing Wages," certified by the industrial statistician of the Department of Labor and Industries, prior to any payments. The "Statement of Intent to Pay Prevailing Wages" shall include: (1) the Contractor's registration number; and (2) the prevailing wages under RCW 39.12.020 and the number of workers in each classification. Each voucher claim submitted by a Contractor for payment on a project estimate shall state that the prevailing wages have been paid in accordance with the pre-filed statement or statements of intent to pay prevailing wages on file with the City. At the end of the work, the Contractor and subcontractors must submit an "Affidavit of Wages Paid," certified by the industrial statistician.
- B. **STATEMENT OF INTENT TO PAY PREVAILING WAGES TO BE POSTED.** For contracts in excess of \$10,000, the Contractor and each subcontractor required to pay the prevailing rate of wages shall post in a location readily visible at the job site: (1) a copy of a "Statement of Intent to Pay Prevailing Wages" approved by the industrial statistician of the Washington State Department of Labor and Industries (L & I); and (2) the address and telephone number of the industrial statistician of the Department of Labor and Industries where a complaint or inquiry concerning prevailing wages may be made.
- C. A payment/performance bond is NOT required.
- D. Statutory retainage is NOT required.

7. CITY OF SPOKANE BUSINESS LICENSE.

Section 8.01.070 of the Spokane Municipal Code states that no person may engage in business with the City without first having obtained a valid annual business registration. The Contractor shall be responsible for contacting the State of Washington Business License Services at www.dor.wa.gov or 360-705-6741 to obtain a business registration. If the Contractor does not believe it is required to obtain a business registration, it may contact the City's Taxes and Licenses Division at (509) 625-6070 to request an exemption status determination.

8. SOCIAL EQUITY REQUIREMENTS / NON-DISCRIMINATION.

No individual shall be excluded from participation in, denied the benefit of, subjected to discrimination under, or denied employment in the administration of or in connection with this Agreement because of age, sex, race, color, religion, creed, marital status, familial status, sexual orientation including gender expression or gender identity, national origin, honorably discharged veteran or military status, the presence of any sensory, mental or physical disability, or use of a service animal by a person with disabilities. The Contractor agrees to comply with, and to require that all subcontractors comply with, federal, state and local nondiscrimination laws, including but not limited to: the Civil Rights Act of 1964, the Rehabilitation Act of 1973, the Age Discrimination in Employment Act, and the American's With Disabilities Act, to the extent those laws are applicable.

9. INDEMNIFICATION.

The Contractor shall defend, indemnify, and hold the City and its officers and employees harmless from all claims, demands, or suits at law or equity-asserted by third parties for bodily injury (including death) and/or property damage which arise from the Contractor's negligence or willful misconduct under this Agreement, including attorneys' fees and litigation costs; provided that nothing herein shall require a Contractor to indemnify the City against and hold harmless the City from claims, demands or suits based solely upon the negligence of the City, its agents, officers, and employees. If a claim or suit is caused by or results from the concurrent negligence of the Contractor's agents or employees and the City, its agents, officers and employees, this indemnity provision shall be valid and enforceable to the extent of the negligence of the Contractor, its agents or employees. The Contractor specifically assumes liability and agrees to defend, indemnify, and hold the City harmless for actions brought by the Contractor's own employees against the City and, solely for the purpose of this indemnification and defense, the Contractor specifically waives any immunity under the Washington State industrial insurance law, or Title 51 RCW. The Consultant/Contractor/Company recognizes that this waiver was specifically entered into pursuant to the provisions of RCW 4.24.115 and was the subject of mutual negotiation. The indemnity and agreement to defend and hold the City harmless provided for in this section shall survive any termination or expiration of this agreement.

10. INSURANCE.

During the period of the Agreement, the Contractor shall maintain in force at its own expense, each insurance noted below with companies or through sources approved by the State Insurance Commissioner pursuant to Title 48 RCW:

A. **Worker's Compensation Insurance** in compliance with RCW 51.12.020, which requires subject employers to provide workers' compensation coverage for all their subject workers and Employer's Liability Insurance in the amount of \$1,000,000;

B. **General Liability Insurance** on an occurrence basis, with a combined single limit of not less than \$1,000,000 each occurrence for bodily injury and property damage. It shall include contractual liability coverage for the indemnity provided under this agreement. It shall provide that

the City, its officers and employees are additional insureds but only with respect to the Contractor's services to be provided under this Agreement;

C. **Automobile Liability Insurance** with a combined single limit, or the equivalent of not less than \$1,000,000 each accident for bodily injury and property damage, including coverage for owned, hired and non-owned vehicles; and

D. **Property Insurance** if materials and supplies are furnished by the Contractor. The amount of the insurance coverage shall be the value of the materials and supplies of the completed value of improvement. Hazard or XCU (explosion, collapse, underground) insurance should be provided if any hazard exists.

There shall be no cancellation, material change, reduction of limits or intent not to renew the insurance coverage(s) without sixty (60) days written notice from the Contractor or its insurer(s) to the City. As evidence of the insurance coverages required by this Agreement, the Contractor shall furnish acceptable insurance certificates to the City at the time it returns the signed Agreement. The certificate shall specify all of the parties who are additional insureds, and include applicable policy endorsements, the sixty (60) day cancellation clause, and the deduction or retention level. The Contractor shall be financially responsible for all pertinent deductibles, self-insured retentions, and/or self-insurance.

11. SUBCONTRACTOR RESPONSIBILITY.

The Contractor must verify responsibility criteria for each first-tier subcontractor, and a subcontractor of any tier that hires other subcontractors must verify responsibility criteria for each of its subcontractors. Verification shall include that each subcontractor, at the time of subcontract execution, meets the responsibility criteria listed in RCW 39.04.350(1) and possesses an electrical contractor license, if required by chapter 19.28 RCW, or an elevator contractor license, if required by chapter 70.87 RCW.

12. INDEPENDENT CONTRACTOR.

The Contractor is an independent Contractor. This Agreement does not intend the Contractor to act as a City employee. The City has neither direct nor immediate control over the Contractor nor the right to control the manner or means by which the Contractor works. Neither the Contractor nor any Contractor employee shall be an employee of the City. This Agreement prohibits the Contractor to act as an agent or legal representative of the City. The Contractor is not granted express or implied rights or authority to assume or create any obligation or responsibility for or in the name of the City, or to bind the City. The City is not liable for or obligated to pay sick leave, vacation pay, or any other benefit of employment, nor to pay social security or other tax that may arise from employment. The Contractor shall pay all income and other taxes as due.

13. ASSIGNMENT AND SUBCONTRACTING.

The Contractor shall not assign or subcontract its obligations under this Agreement without the City's written consent, which may be granted or withheld in the City's sole discretion. Any subcontract made by the Contractor shall incorporate by reference this Agreement, except as otherwise provided. The Contractor shall ensure that all subcontractors comply with the obligations and requirements of the subcontract. The City's consent to any assignment or subcontract does not release the Contractor from liability or any obligation within this Agreement, whether before or after City consent, assignment or subcontract.

14. TERMINATION.

Either party may terminate this Agreement, with or without cause, by ten (10) days written notice to the other party. In the event of such termination, the City shall pay the Contractor for all work previously authorized and performed prior to the termination date.

15. STANDARD OF PERFORMANCE.

The standard of performance applicable to Contractor's services will be the degree of skill and diligence normally employed by professional contractors in the region performing the same or similar Contracting services at the time the work under this Agreement are performed.

16. ANTI KICK-BACK.

No officer or employee of the City of Spokane, having the power or duty to perform an official act or action related to this Agreement shall have or acquire any interest in the Agreement, or have solicited, accepted or granted a present or future gift, favor, service or other thing of value from or to any person involved in this Agreement.

17. CONSTRUAL.

The Contractor acknowledges receipt of a copy of the Agreement documents and agrees to comply with them. The silence or omission in the Agreement documents concerning any detail required for the proper execution and completion of the work means that only the best general practice is to prevail and that only material and workmanship of the best quality are to be used. This Contract shall be construed neither in favor of nor against either party.

18. DEBARMENT AND SUSPENSION.

The Contractor has provided its certification that it is in compliance with and shall not contract with individuals or organizations which are debarred, suspended, or otherwise excluded from or ineligible from participation in Federal Assistance Programs under Executive Order 12549 and "Debarment and Suspension", codified at 29 CFR part 98.

19. CONTRACTOR'S ACKNOWLEDGEMENT AND WARRANTY.

The Contractor acknowledges that it has visited the site of the work, has examined it, and is qualified to perform the work required by this Agreement.

The Contractor guarantees and warranties all work, labor and materials under this Agreement for one (1) year following final acceptance. If any unsatisfactory condition or defect develops within that time, the Contractor will immediately place the work in a condition satisfactory to the City and repair all damage caused by the condition or defect. The Contractor will repair or restore to the City's satisfaction, in accordance with the contract documents and at its expense, all property damaged by his performance under this Agreement. This warranty is in addition to any manufacturers' or other warranty in the Agreement documents.

20. MISCELLANEOUS PROVISIONS.

- A. **Amendments/Modifications:** The City may modify this Agreement and order changes in the work whenever necessary or advisable. The Contractor will accept modifications when ordered in writing by the City, and the Agreement time and compensation will be adjusted accordingly.
- B. The Contractor, at no expense to the City, shall comply with all laws of the United States and Washington, the Charter and ordinances of the City of Spokane; and rules, regulations, orders and directives of their administrative agencies and officers.
- C. This Agreement shall be construed and interpreted under the laws of Washington. The venue of any action brought shall be in a court of competent jurisdiction, located in Spokane County, Washington.
- D. **Captions:** The titles of sections or subsections are for convenience only and do not define or limit the contents.
- E. **Severability:** If any term or provision is determined by a court of competent jurisdiction to be invalid or unenforceable, the remainder of this Agreement shall not be affected, and

each term and provision shall be valid and enforceable to the fullest extent permitted by law.

- F. **Waiver:** No covenant, term or condition or the breach shall be deemed waived, except by written consent of the party against whom the waiver is claimed, and any waiver of the breach of any covenant, term or condition shall not be deemed a waiver of any preceding or succeeding breach of the same or any other covenant, term of condition. Neither the acceptance by the City of any performance by the Contractor after the time the same shall have become due nor payment to the Contractor for any portion of the Work shall constitute a waiver by the City of the breach or default of any covenant, term or condition unless otherwise expressly agreed to by the City in writing.
- G. **Entire Agreement:** This document along with any exhibits and all attachments, and subsequently issued addenda, comprises the entire agreement between the City and the Contractor. If conflict occurs between Agreement documents and applicable laws, codes, ordinances or regulations, the most stringent or legally binding requirement shall govern and be considered a part of this Agreement to afford the City the maximum benefits.
- H. **No personal liability:** No officer, agent or authorized employee of the City shall be personally responsible for any liability arising under this Agreement, whether expressed or implied, nor for any statement or representation made or in any connection with this Agreement.
- I. Under Washington State Law (reference RCW Chapter 42.56, the *Public Records Act* [PRA]) all materials received or created by the City of Spokane are **public records** and are available to the public for viewing via the City Clerk's Records (online) or a valid Public Records Request (PRR).

IN WITNESS WHEREOF, in consideration of the terms, conditions and covenants contained, or attached and incorporated and made a part, the parties have executed this Agreement by having legally-binding representatives affix their signatures below.

ACI NORTHWEST, INC..

CITY OF SPOKANE

By _____
Signature Date

By _____
Signature Date

Type or Print Name

Type or Print Name

Title

Title

Attest:

Approved as to form:

City Clerk

Assistant City Attorney

Attachments that are part of this Agreement:

Attachment A – Debarment Certification

Attachment B - Certification of Compliance with Wage Payment Statutes

Attachment C – Contractor's Response to IPWQ

ATTACHMENT A

**CERTIFICATION REGARDING DEBARMENT, SUSPENSION,
INELIGIBILITY AND VOLUNTARY EXCLUSION**

1. The undersigned (i.e., signatory for the Subrecipient / Contractor / Consultant) certifies, to the best of its knowledge and belief, that it and its principals:
 - a. Are not presently debarred, suspended, proposed for debarment, declared ineligible, or voluntarily excluded from covered transactions by any federal department or agency;
 - b. Have not within a three-year period preceding this contract been convicted or had a civil judgment rendered against them for commission of fraud or a criminal offense in connection with obtaining, attempting to obtain, or performing a public (federal, state, or local) transaction or contract under a public transaction; violation of federal or state antitrust statutes or commission of embezzlement, theft, forgery, bribery, falsification or destruction of records, making false statements, tax evasion, receiving stolen property, making false claims, or obstruction of justice;
 - c. Are not presently indicted or otherwise criminally or civilly charged by a government entity (federal, state, or local) with commission of any of the offenses enumerated in paragraph (1)(b) of this certification; and,
 - d. Have not within a three-year period preceding this contract had one or more public transactions (federal, state, or local) terminated for cause or default.
2. The undersigned agrees by signing this contract that it shall not knowingly enter into any lower tier covered transaction with a person who is debarred, suspended, declared ineligible, or voluntarily excluded from participation in this covered transaction.
3. The undersigned further agrees by signing this contract that it will include the following clause, without modification, in all lower tier covered transactions and in all solicitations for lower tier covered transactions:

Certification Regarding Debarment, Suspension, Ineligibility and Voluntary Exclusion – Lower Tier Covered Transactions

1. The lower tier contractor certified, by signing this contract that neither it nor its principals is presently debarred, suspended, proposed for debarment, declared ineligible, or voluntarily excluded from participation in this transaction by any federal department or agency.
 2. Where the lower tier contractor is unable to certify to any of the statements in this contract, such contractor shall attach an explanation to this contract.
4. I understand that a false statement of this certification may be grounds for termination of the contract.

_____ Name of Subrecipient / Contractor / Consultant (Type or Print)	_____ Program Title (Type or Print)
_____ Name of Certifying Official (Type or Print)	_____ Signature
_____ Title of Certifying Official (Type or Print)	_____ Date (Type or Print)



ATTACHMENT B

**Certification of Compliance with Wage Payment Statutes and
Washington Department of Labor and Industries Training
Requirement**

The bidder hereby certifies that, within the three-year period immediately preceding the bid solicitation date (_____), the bidder is not a “willful” violator, as defined in RCW 49.48.082, of any provision of chapters 49.46, 49.48, or 49.52 RCW, as determined by a final and binding citation and notice of assessment issued by the Department of Labor and Industries or through a civil judgment entered by a court of limited or general jurisdiction.

As of July 1, 2019, have fulfilled the Department of Labor and Industries’ Public Works and Prevailing Wage Training Requirement before bidding and/or performing work on public works projects under RCW 39.04.350 and RCW 39.06.020 by either of the following:

- 1) Received training on the requirements related to public works and prevailing wage under chapter RCW 39.04.350 and chapter 39.12; or
- 2) Be certified exempt by the Department of Labor and Industries by having completed three or more public work projects and have a had a valid business license in Washington for three or more years.

I certify under penalty of perjury under the laws of the State of Washington that the foregoing is true and correct.

Bidder’s Business Name

Signature of Authorized Official*

Printed Name

Title

Date

City

State

Check One:

Sole Proprietorship Partnership Joint Venture Corporation

State of Incorporation, or if not a corporation, State where business entity was formed:

If a co-partnership, give firm name under which business is transacted:

** If a corporation, proposal must be executed in the corporate name by the president or vice-president (or any other corporate officer accompanied by evidence of authority to sign). If a co-partnership, proposal must be executed by a partner.*

ATTACHMENT C



BID TABULATION

IPWQ 6154-24
REBID

HVAC Preventative Maintenance On Call PW

<p>As a cost comparison for this bid, we are using the all-inclusive yearly cost to perform Scheduled Quarterly/Preventative Maintenance requirements. We also be using four (4) unscheduled emergency calls per year for an overall total of 16 hours, at an Emergency Hourly Rate. And thirty (30) unscheduled non-emergency calls per year for an estimated total of 200 hours per year, of which 75% or a 150 estimated hours would be at that Straight Hourly Rate; and 25%, or 50 estimated hours would be at the Overtime Hourly Rate. Associated Travel Cost for Unscheduled Calls will be used based an estimated thirty-four (34) unscheduled calls per year, with 4 being emergency calls and 30 being non-emergency calls.</p>		Estimated Quantity More or Less	MACDONI
Scheduled Service	<p>Scheduled Service: Quarterly/Preventative Maintenance inclusive of all labor, travel, material cost (to include but not limited to filters, belts, gaskets, oils, lubricants) to perform all required Quarterly/Preventative Maintenance requirements that for a 12 month period. Enter all-inclusive YEARLY COST for the 12-month period to be incurred here. Cost should not include tax</p>		
Unscheduled Service:	<p>Cost per Unscheduled Service Call. Thirty-four (34) unscheduled calls are estimated for a 12-month period, with 4 being emergency calls and 30 being non-emergency calls. Enter the Travel Cost to be incurred per-an-individual call out.</p>	34	100
Unscheduled Service:	<p>Percentage Markup for unscheduled service will remain unchanged throughout the life of the contract and any renewals.</p>		
Straight Time Rate (150 hours)		150	135.00
Overtime Rate (50 hrs)		50	202.50

Emergency Work Rate (16 hours)	16	135.00
Holiday Rate (1 hour)	1	270.00
Other Cost		NA
Subtotal		
Applicable Tax		
Extended Total		

--



DALD MILLER	ACI NORTHWEST INC		MCKINSTRY		HOLADAY PARKS INC	
YEARLY COST for the 12-month period to be incurred here.		YEARLY COST for the 12-month period to be incurred here.		YEARLY COST for the 12-month period to be incurred here.		YEARLY COST for the 12-month period to be incurred here.
28,452.00		38,000.00		58,849.00		163,500.00
3,400.00	0	0.00	35	1,190.00	216	7,344.00
MARKUP SCHEDULE ATTACHED		65%		0.25		30-35%
20,250.00	135	20,250.00	135	20,250.00	175	26,250.00
10,125.00	200	10,000.00	202.5	10,125.00	262.5	13,125.00

2,160.00	200	3,200.00	135	2,160.00	262.5	4,200.00
270.00	200	200.00	270	270.00	350	350.00
	0		SEE BID RESPONSE		TRUCK CHARGE	2,720.00
64,657.00		71,650.00		98,998.00		214,769.00
5,819.13		6,448.50		8,909.82		19,329.21
70,476.13		78,098.50		107,907.82		234,098.21

Bid Response Summary

Bid Number IPWQ 6154-24
Bid Title HVAC Preventative Maintenance On Call PW (Re-Bid)
Due Date Thursday, June 20, 2024 3:30:00 PM [(UTC-08:00) Pacific Time (US & Canada)]
Bid Status Closed to Bidding
Company ACI NORTHWEST INC
Submitted By Bill Radobenko - Thursday, June 20, 2024 10:55:34 AM [(UTC-08:00) Pacific Time (US & Canada)]
 bradobenko@acinw.com

Comments

Question Responses

Group	Reference Number	Question	Response
MANDATORY Pre Bid Meeting			
	1.	MANDATORY pre-bid meeting and walk through will be held on Thursday, 06/13/2024 at 10:00AM. The location will be at the Riverside Park Reclamation Facility HVAC (RPRWF), Lobby Area, 4401 N. Aubrey L. White Parkway, Spokane, WA 99205.	I acknowledge and agree
Default Item Group			
	CONTRACTOR'S REPRESENTATION	The Contractor by making its Quote represents that it has read and understands the specifications.	I acknowledge and agree
	QUALIFICATION	Prior to the award of Contract, the Contractor shall be required to submit evidence of sufficient facilities, equipment, experience and financial ability to insure completion of the Work, unless waived by the City.	I acknowledge and agree
	AWARD OF CONTRACT	Award of Contract, when made by the City, will be to lowest responsive responsible bidder based on rates and most favorable service. The contract awarded will be valid for a three-year base period. Unsuccessful Contractors will not automatically be notified of results.	I acknowledge and agree
	CONTRACT RENEWALS	Contract renewals or extensions may be initiated by the City of Spokane, subject to mutual agreement. This contract may be renewed for two (2) one-year options with the total contract period not to exceed five (5) years.	I acknowledge and agree

EXECUTION OF CONTRACT	Within ten (10) days of contract award, the Contractor shall sign and return to the City an executed copy of the contract and approved evidence of insurance unless otherwise mutually agreed by the City and Contractor.	I acknowledge and agree
GUARANTEE	The Contractor guarantees all work, labor and materials for one (1) year following final acceptance. If any unsatisfactory condition or defect develops within that time, the Contractor shall immediately place the work in a satisfactory condition, and further repair all damage caused by the condition or defect at the contractor's sole expense. This guarantee shall not apply to work which has been abused or neglected by the City.	I acknowledge and agree
INVOICING	Invoices must be submitted to Riverside Park Reclamation Facility within 30 days of performing the work. • Invoices shall include the location and type of services performed, detailed hours and rate per hour, and on site contact that approved services. • Invoices shall reference and list OPR #2024-XXXX and approved Intent to Pay Prevailing Wage Number. • Payment of invoices shall be contingent upon receipt of sufficient detail to permit identification of the services performed and compliance with contract conditions. Original invoices are required and shall not be approved for payment until all services per request have been satisfactorily performed. Invoices shall be emailed to hbarnhart@spokanecity.org or mailed to Riverside Park Reclamation Facility, Attn: Office Manager, 4401 N. Aubrey L. White Parkway, Spokane, WA 99205	I acknowledge and agree
PAYMENT	Payment will be made via direct deposit/ACH after receipt of the Contractor's application except as provided by state law. If the City objects to all or any portion of the invoice, it shall notify the Contractor and reserves the right to only pay that portion of the invoice not in dispute. In that event, the parties shall immediately make every effort to settle the disputed amount.	I acknowledge and agree
REJECTION OF QUOTES	The City reserves the right to reject any or all Quotes, to waive minor deviations from the specifications, to waive minor informalities in Quote process whenever it is in the City's best interest, and to accept or reject all or part of this Request for Quotes, at the prices shown.	I acknowledge and agree

CONTRACTOR REGISTRATION	The Contractor shall be a Washington State registered or licensed contractor at time of Quote submittal.	I acknowledge and agree	
COMPLETION TIME	Work must be completed in a reasonable amount of time, contractor cannot leave our work incomplete to go to another job. If repair is delayed due to needed parts, estimated wait time and shipping tracking information must be provided. If for any reason the contractor is unable to respond in a reasonable amount of time, the City reserves the right to go outside the contract and work with another contractor.	I acknowledge and agree	
CONTRACTOR CONTACT INFORMATION	Please indicate Name, Telephone Number and E-Mail address for the person submitting this Quote response.	Mike Jones, 208-659-2120, mjones@acirw.com	
CONTRACTOR CONTACT INFORMATION	Provide the name, phone number, and email address for the person in your Company that would potentially sign a contract through the DocuSign process used by the City.	Mike Jones, 208-659-2120, mjones@acirw.com	
EXCEPTIONS	If you marked "I do not acknowledge and agree" on any of the areas above, explain here what you are taking exception to.		
ADDITIONAL INFORMATION	If you have additional information/documents to submit, upload them here.		
PUBLIC WORKS REQUIREMENTS			
A.	The work under this contract is classified as routine maintenance under state law.	I acknowledge and agree	
1.	A payment/performance bond is NOT required	I acknowledge and agree	
2.	Statutory retainage is NOT required	I acknowledge and agree	
B.	Prevailing Wage	I acknowledge and agree	
1.	The State prevailing rate of wages to be paid to all workmen, laborers or mechanics employed in the performance of any part of this Contract shall be in accordance with the provisions of Chapter 39.12 of the Revised Code of Washington (RCW) and the rules and regulations of the Washington State Department of Labor and Industries (L & I).	I acknowledge and agree	

2.	<p>The State of Washington prevailing wage rates applicable for this public works project, which is located in Spokane County, may be found at the following website address of the Department of Labor and Industries: https://fortress.wa.gov/lni/wagelookup/prvWagelookup.aspx. Prevailing wages for all work performed pursuant to each work order must be the prevailing wage rates in effect at the beginning date for each contract year. On call contracts must have prevailing wage rates updated annually. Intents and affidavits for prevailing wages paid must be submitted annually for all work completed within the previous twelve-month period of the unit priced contract. (RCW 35.22.620) Upon the anniversary date of the contract, labor rates may be adjusted according to the revised prevailing wages adopted by the Department of Labor and Industries at that time. In order to calculate the change in prevailing wages due to the Contractor, the Contractor shall provide to the City of Spokane a breakdown of the fully loaded labor rates for each classification of labor including hourly wage rates, fringe benefits, overhead and profit. The City of Spokane shall not pay for any price escalation for overhead, profit, equipment, material, or any other costs except for changes in the prevailing wages. The revised prevailing wages shall be effective for any Work issued after the anniversary date of the contract. The basis of modified prevailing wage rates applicable for the contract shall be calculated and issued in writing by the City of Spokane, but such changes shall not be included in a change order. To the extent that the contract sum changes, a change order will be issued as appropriate.</p>	I acknowledge and agree
C.	Apprenticeship	I acknowledge and agree
1.	If apprentices are to be used, they must be registered with the State Apprenticeship Council; otherwise, they are to be paid State prevailing journeyman wages.	I acknowledge and agree
D.	Statement of Intent	I acknowledge and agree

1.	The Contractor and subcontractors will submit a "Statement of Intent to Pay Prevailing Wages" certified by the industrial statistician of the Department of Labor and Industries, prior to any work or payments. The "Statement of Intent to Pay Prevailing Wages" shall include: (1) the Contractor's registration number; and (2) the prevailing wages under RCW 39.12.020 and the number of workers in each classification. Prior to payment of funds held under RCW 39.12.040, the Contractor and subcontractors must submit an "Affidavit of Wages Paid" certified by the industrial statistician annually for all work completed within the previous twelve-month period of the unit priced contract (RCW 35.22.620).	I acknowledge and agree	
E.	Filing Fees	I acknowledge and agree	
1.	The fee for the approval of 1) "Statements of Intent to Pay Prevailing Wages" and 2) "Affidavits of Wages Paid" is forty dollars (\$40) for each form. The Contractor is responsible for payment of these fees and shall make all applications directly to L & I.	I acknowledge and agree	
F.	Department of Labor and Industries' Public Works and Prevailing Wage Training	I acknowledge and agree	
1.	As of July 1, 2019 contractors must have fulfilled the Department of Labor and Industries' Public Works and Prevailing Wage Training Requirement before bidding and/or performing work on public works projects under RCW 39.04.350 and RCW 39.06.020	I acknowledge and agree	
EXCEPTIONS	If you marked "I do not acknowledge and agree" on any of the areas above, explain here what you are taking exception to.		
GENERAL CONDITIONS			
#1	Contractor acknowledges that they have read and understand the General Conditions Document in the "Documents" tab.	I acknowledge and agree	
TECHNICAL REQUIREMENTS			

Performance	The Contractor will do all work, furnish all labor, materials, tools, construction equipment, transportation, supplies, supervision, permits, organization and other items of work and cost necessary for the proper execution and completion of the described Work. The apparent silence or omission as to any detail of any Work to be done or materials to be furnished and required for the proper performance of the Work, shall be regarded as meaning that the best general practice is to prevail, and that material and workmanship of the best quality are to be used, and interpretation of the scope of work shall be made upon this basis.	I acknowledge and agree	
Performance	PERMITS. The Contractor shall be responsible for obtaining at its expense all permits required by regulatory agencies.	I acknowledge and agree	
Scope of Work	This scope is intended to provide clarification and is NOT intended to be a complete listing of the contractor's responsibilities.	I acknowledge and agree	
Scope of Work	Riverside Park Water Reclamation Facility (RPWRF) seeks an HVAC Service Provider Contract with a HVAC established and experienced company to provide Unscheduled and Scheduled HVAC Services. Vendor shall ensure techs and service/recovery equipment to be EPA-certified in regard to the Recovery of CFCs. Vendor shall provide copies of tech's certificates with proposals. The Contractor shall do all work, furnish all labor, materials, tools, equipment, transportation, supplies, supervision, permits, organization and other items of work and cost necessary for the proper execution and completion of the HVAC Services for RPWRF, 4401 N. Aubrey L. White Parkway, Spokane WA 99205.	I acknowledge and agree	

Scope of Work	Maintenance activities will be performed during normal business hours (7:30 a.m. to 4:00 p.m., Monday - Friday), with the option for after-hours arrangements. Vendor shall coordinate services with RPWRF HVAC Supervisor. Procedures shall be conducted in accordance with the manufacturer's specification. Vendor shall perform the necessary testing and calibration, to identifying defects and potential problem areas. "Department shall provide all maintenance materials, such as but limited to belts, filters, gaskets, oils, lubricants required. "	I acknowledge and agree
Scope of Work	Contractor shall test and cycle all equipment after service is complete, to ensure proper operational conditions. After performing services, Vendor shall provide a service report with written documentation of tasks performed.	I acknowledge and agree
Scope of Work	Contractor to provide a complete master equipment list to the department within the first 12 months of contract. Equipment list should include manufacturer, model number and serial number	I agree
Scope of Work - Unscheduled Services	Emergency calls, Contractor shall be onsite within 4 hours of notification. On average it is estimated that there are 4 Emergency calls per year that could result in an estimated annual total of 16 hours more or less. (These numbers are just estimates for evaluation purposes)	I acknowledge and agree
Scope of Work - Unscheduled Services	Non-emergency calls, Contractor shall be onsite within 24 hours of notification. On average it is estimated that there are 30 Emergency calls per year, that could result in an estimated annual total of 200 hours more or less. (These numbers are just estimates for evaluation purposes)	I acknowledge and agree
Scope of Work - Scheduled Services Quarterly/Preventative Maintenance:	Mid-Summer / Mid-Winter Services provides a test and inspection service which verifies equipment operation during peak season operation.	I acknowledge and agree

Scope of Work - Scheduled Services Quarterly/Preventative Maintenance:	Filter Service: Shall install air filter media. Service will be performed as required, during the scheduled service, for the applicable items on the equipment list. If changing environmental conditions or experience indicates that the filter-changing schedule needs to be adjusted, it will be modified by mutual consent. Contractor shall provide 6 filter change(s) per unit, per year. Filters will be provided by the Department.	I acknowledge and agree	
Scope of Work - Scheduled Services Quarterly/Preventative Maintenance:	Belt Replacement Service: Replace drive belts on an annual basis. Contractor shall provide 1 belt change per unit, per year. Belts will be provided by the Department.	I acknowledge and agree	
Scope of Work - Scheduled Services Quarterly/Preventative Maintenance:	Condenser Coil Cleaning Service: Condenser coil cleaning will be accomplished annually during the cooling season. If changing environmental conditions or experience indicates that the above condenser coil-cleaning schedule needs to be adjusted, it will be modified by mutual consent. Contractor shall provide 1 coil cleanings per unit, per year.	I acknowledge and agree	
Scope of Work - Scheduled Services Quarterly/Preventative Maintenance:	From the Documents Tab, the Contractor has reviewed the items to be covered for "Quarterly/Preventative Maintenance".	I acknowledge and agree	
Scope of Work	SUBCONTRACTORS. The Contractor shall not award work to any subcontractor without the City's prior approval. The Contractor shall be fully responsible to the City for the acts and omissions of its subcontractors. No contractual relationship shall be created between any subcontractor and the City.	I acknowledge and agree	
Scope of Work	Completion of work, whenever possible, in the most timely and cost efficient manner for the citizens of Spokane.	I acknowledge and agree	
Scope of Work	The winning Contractor shall receive a unit priced contract and, upon complete and accepted performance by the Contractor, the City shall issue payment in the applicable amount set forth on the Pricing Tab for the actual services performed.	I acknowledge and agree	
Professionalism	Successful Contractor will fulfill contract in a responsible, professional manner at all times. Representatives shall dress appropriately and use acceptable health and safety practices.	I acknowledge and agree	

Safety	The Contractor shall be responsible for implementing and maintaining their own safety program during the work. The Contractor will be required to participate in the Facility's safety orientation prior to any work activities at the RPWRF.	I acknowledge and agree	
Safety	Bidder has read and understand the Contractor Safety and Environmental Requirements document that is located in the "Documents" tab.	I acknowledge and agree	
Safety	The RPWRF Lock Out/Tag out (LOTO) system shall be used during all work activities. A copy of RPWRF LOTO Policy will be provided upon request. The Contractor shall use their own hard locks as part of these LOTO procedures.	I acknowledge and agree	
QUOTE			
Evaluating	As a cost comparison for this bid, we are using the all-inclusive yearly cost to perform Scheduled Quarterly/Preventative Maintenance requirements. We will also be using four (4) unscheduled emergency calls per year for an overall total of 16 hours, at an Emergency Hourly Rate. And thirty (30) unscheduled non-emergency calls per year for an estimated total of 200 hours per year, of which 75% or 150 estimated hours would be at that Straight Hourly Rate; and 25%, or 50 estimated hours would be at the Overtime Hourly Rate. Associated Travel Cost for Unscheduled Calls will be used based an estimated thirty-four (34) unscheduled calls per year, with 4 being emergency calls and 30 being non-emergency calls.	I acknowledge and agree	
Scheduled Service:	Scheduled Service: Quarterly/Preventative Maintenance inclusive of all labor, travel, material cost to perform all required Quarterly/Preventative Maintenance requirements that for a 12 month period. Enter all-inclusive YEARLY COST for the 12-month period to be incurred here. Cost should not include tax.	\$38,000	
Unscheduled Service	Travel Cost per Unscheduled Service Call. Thirty-four (34) unscheduled calls are estimated for a 12-month period, with 4 being emergency calls and 30 being non-emergency calls. Enter the Travel Cost to be incurred per-an-individual call out.	NA	

Unscheduled Service	Percentage Markup for Parts/Materials pertaining to Unscheduled Service. Materials and parts required for Unscheduled Service will be paid at Contractor's cost plus percentage markup. Enter Percentage Markup above Contractor's cost that would be applied.	65%	
Unscheduled Service	Percentage Markup for unscheduled service will remain unchanged throughout the life of the contract and any renewals.	I acknowledge and agree	
Straight Time Rate	Hourly Rate -	\$135.00	
Overtime Rate	Hourly Rate -	\$200.00	
Emergency Work Rate	Hourly Rate -	\$200.00	
Holiday Rate	Hourly Rate -	\$200.00	
Other Cost	Bidders are to list any other cost that could be incurred. If not listed would not be allowed.	NA	
Quoting Errors	Unit pricing will prevail in the circumstance of unit and extension pricing discrepancies. When, after the opening and tabulation of Bids, a Bidder claims error, and requests to be relieved of award, he will be required to promptly present certified work sheets. The Purchaser will review the work sheets and if the Purchaser is convinced, by clear and convincing evidence, that an honest, mathematically excusable error or critical omission of costs has been made, the Bidder may be relieved of his Bid.	I acknowledge and agree	
Addenda	Indicate how many Addenda the Contractor acknowledges receipt of and agrees that its requirements have been included in this Quote.	1	
Withdrawal of Quote	The Contractor agrees that its Quote will NOT be withdrawn for a minimum of sixty (60) calendar days after the stated submittal date.	I acknowledge and agree	
Subcontractors	Download and complete the Subcontractor List in the "Documents" tab and upload it.	Subcontractor List under \$1M (5).pdf	
CONTRACTOR RESPONSIBILITY			
#1	Provide Washington State Contractor's Registration No.	ACINOI*922D8	
#2	Provide Contractor's U.B.I. Number	601-746-223	
#3	Provide Contractor's Washington Employment Security Department Number	NA	

#4	Provide Contractor's Washington Excise Tax Registration Number	A16694623
#5	Provide Contractor's City of Spokane Business Registration Number	601746223
CERTIFICATION OF COMPLIANCE WITH WAGE PAYMENT STATUS		
#1	The Contractor hereby certifies that, within the three-year period immediately preceding the bid solicitation date for this Project, the contractor is not a "willful" violator, as defined in RCW 49.48.082, of any provision of chapters 49.46, 49.48, or 49.52 RCW, as determined by a final and binding citation and notice of assessment issued by the Department of Labor and Industries or through a civil judgment entered by a court of limited or general jurisdiction. I certify (or declare) under penalty of perjury under the laws of the State of Washington that the foregoing is true and correct.	I acknowledge and agree

SUBCONTRACTOR LIST

PROJECT NAME: Bid # IPWQ 6154-24

IMPORTANT: REFER TO SECTION 5.2.1 OF THE SUPPLEMENTAL CONDITIONS FOR INSTRUCTIONS ON COMPLETING THE SUBCONTRACTOR LIST *(use additional pages if necessary):*

CONTRACTOR/SUPPLIER _____

TYPE OF WORK/BID ITEM _____

AMOUNT _____

CONTRACTOR'S REGISTRATION NO. _____

CONTRACTOR/SUPPLIER _____

TYPE OF WORK/BID ITEM _____

AMOUNT _____

CONTRACTOR'S REGISTRATION NO. _____

CONTRACTOR/SUPPLIER _____

TYPE OF WORK/BID ITEM _____

AMOUNT _____

CONTRACTOR'S REGISTRATION NO. _____

CONTRACTOR/SUPPLIER _____

TYPE OF WORK/BID ITEM _____

AMOUNT _____

CONTRACTOR'S REGISTRATION NO. _____

 X NO SUBCONTRACTORS WILL BE USED ON THIS PROJECT



Agenda Sheet for City Council:

Committee: Date: N/A

Committee Agenda type:

Council Meeting Date: 08/12/2024

Date Rec'd 7/24/2024

Clerk's File # CPR 2024-0002

Cross Ref #

Project #

Submitting Dept ACCOUNTING & GRANTS **Bid #**

Contact Name/Phone LEONARD 625-6028 **Requisition #**

Contact E-Mail LDAVIS@SPOKANECITY.ORG

Agenda Item Type Claim Item

Council Sponsor(s)

Agenda Item Name 5600-CLAIMS-2024

Agenda Wording

Report of the Mayor of pending claims & payments of previously approved obligations through: 07/19/2024. Total:\$7,532,086.90 with Parks & Library claims being approved by their respective boards. Claims excluding Parks & Library Total:\$6,815,535.78

Summary (Background)

Pages 1-23 Check numbers: 604311 - 604449 Credit Card numbers: 000403 - 000427 ACH payment numbers: 131457 - 131660 On file for review in City Clerks Office: 23 Page listing of Claims Note:

Lease? NO Grant related? NO Public Works? NO

Fiscal Impact

Approved in Current Year Budget?

Total Cost \$ 6,815,535.78

Current Year Cost \$

Subsequent Year(s) Cost \$

Narrative

Amount	Budget Account
Expense \$ 6,815,535.78	# Various
Select \$	#
Select \$	#
Select \$	#
\$	#
\$	#

REPORT: PG3620
SYSTEM: FMSAP
USER: MANAGER
RUN NO: 29

APPROVAL FUND SUMMARY

DATE: 07/22/24
TIME: 07:14
PAGE: 1

FUND	FUND NAME	AMOUNT
0100	GENERAL FUND	270,657.25
1100	STREET FUND	218,402.21
1200	CODE ENFORCEMENT FUND	4,717.34
1360	MISCELLANEOUS GRANTS FUND	900.00
1380	TRAFFIC CALMING MEASURES	7,869.29
1400	PARKS AND RECREATION FUND	8,748.15
1425	AMERICAN RESCUE PLAN	179,997.33
1460	PARKING METER REVENUE FUND	17,350.63
1560	FORFEITURES & CONTRIBUTION FND	3,713.58
1640	COMMUNICATIONS BLDG M&O FUND	5,381.13
1680	CD/HS OPERATIONS	8,258.30
1910	CRIMINAL JUSTICE ASSISTANCE FD	27,121.48
1970	FIRE/EMS FUND	123,893.76
1980	DEFINED CONTRIBUTION ADMIN FND	346.70
3160	GENERAL CAPITAL IMPROVEMENTS	56,511.00
3200	ARTERIAL STREET FUND	566,765.15
4100	WATER DIVISION	576,989.01
4250	INTEGRATED CAPITAL MANAGEMENT	1,023,969.12
4300	SEWER FUND	383,497.25
4480	SOLID WASTE FUND	218,798.59
4600	GOLF FUND	24.00
4700	DEVELOPMENT SVCS CENTER	11,720.93
5100	FLEET SERVICES FUND	159,672.38
5110	FLEET SVCS EQUIP REPL FUND	2,967.63
5200	PUBLIC WORKS AND UTILITIES	23,707.94
5300	IT FUND	45,281.08
5310	IT CAPITAL REPLACEMENT FUND	8,558.03
5400	REPROGRAPHICS FUND	208.41
5600	ACCOUNTING SERVICES	862.31
5700	MY SPOKANE	184.32
5800	RISK MANAGEMENT FUND	38,901.24
5810	WORKERS' COMPENSATION FUND	237.60
5830	EMPLOYEES BENEFITS FUND	951,648.52
5900	FACILITIES MANAGEMENT FUND OPS	41,501.95
5903	PROPERTY ACQUISITION FIRE	6,171.20
5904	FACILITIES CAPITAL	114,646.25
6070	FIREFIGHTERS' PENSION FUND	74,567.68
6080	POLICE PENSION FUND	62,867.41
6730	PARKING & BUSINESS IMPROV DIST	15,133.01
	TOTAL:	5,262,749.16

REPORT: PG3640
SYSTEM: FMSAP
USER: MANAGER
RUN NO: 29

CITY OF SPOKANE
COUNCIL CHECK RANGE/TOTAL

DATE: 07/22/24
TIME: 07:15
PAGE: 1

CHECK #	VENDOR	CITY	LIBRARY	PARKS
	USE TAX AMOUNTS	443.32	8.84	
00604311	NUMERICA CREDIT UNION	111,136.58		
00604312	PITNEY BOWES	33,086.11		
00604313	WA STATE DEPT OF NATURAL			22,764.40
00604314	BOUND TREE MEDICAL LLC	542.97		
00604315	CENTURYLINK	1,268.58		
00604316	COMCAST	225.90		
00604317	WATERCO OF THE PACIFIC NORTH	76.04		
00604318	KAISER FOUNDATION HEALTH OF	275.00		
00604319	KAISER FOUNDATION HEALTH OF	98.00		
00604320	LEVEL 3 FINANCING INC	3,654.31		
00604321	SPOKANE TEACHERS CREDIT UNIO	37.50		
00604322	UNITED RENTALS NW INC	796.58		
00604323	CENTURYLINK			106.35
00604324	COMCAST			188.38
00604325	COMCAST			188.38
00604326	COMCAST			198.01
00604327	COMCAST			698.18
00604328	PARK DEPT IMPREST FUND			191.87
00604329	SPOKANE COUNTY AUDITOR	303.50		
00604330	ACCESS UNLIMITED & SECURITY	183.12		
00604331	CENTURYLINK	5,681.99		
00604332	NORFOLK IRON & METAL CO	637.84		
00604333	WATERCO OF THE PACIFIC NORTH	246.49		
00604334	BERYL FREDRICKSON	477.04		
00604335	KAISER FOUNDATION HEALTH OF	1,414.00		
00604336	KAISER FOUNDATION HEALTH OF	138.00		
00604339	KARI M BRATHEN	541.46		
00604340	DOWNTOWN SPOKANE PARTNERSHIP	14,721.73		
00604341	EAST SPRAGUE BUSINESS	306.81		
00604342	LETICIA BLAND	104.47		
00604343	CURTIS MCSPADDEN	460.00		
00604344	DEBORAH CAMARDA	375.00		
00604345	JOSHUA KABWE	305.00		
00604346	LACY WOOD	311.71		
00604347	PAUL MCARTHUR	243.00		
00604348	TOM WORTHY	1,263.99		
00604349	KEVIN HALL	1,132.70		
00604350	KATHLEEN LANIER	1,132.70		
00604351	MATTHEW MURRAY	980.25		
00604352	SHUMS CODA ASSOCIATES INC	9,000.00		
00604353	SPOKANE CONCRETE CUTTING INC	381.50		
00604354	ERIC P THOMPSON	110.42		
00604355	T-MOBILE	29.75		
00604356	UNITED RENTALS NW INC	1,513.80		
00604357	PRORATE AND FUEL TAX	1,534.92		
00604358	WA STATE DEPT OF REVENUE	15,772.08		
00604359	OVERHEAD DOOR CORPORATION	6,549.81		
00604360	CANNON HILL INDUSTRIES INC			360.00
00604361	J & H TOOLING			222.36
00604362	CONSTRUCTIVE EATING INC			342.90
00604363	DS SERVICES OF AMERICA INC			73.33
00604364	WATERCO OF THE PACIFIC NORTH			459.68

REPORT: PG3640
SYSTEM: FMSAP
USER: MANAGER
RUN NO: 29

CITY OF SPOKANE
COUNCIL CHECK RANGE/TOTAL

DATE: 07/22/24
TIME: 07:15
PAGE: 2

CHECK #	VENDOR	CITY	LIBRARY	PARKS
00604365	FLASHPARKING, INC.			320.12
00604366	KELLER SUPPLY COMPANY			25.03
00604367	MORGAN ZARO			3.25
00604368	MORGAN ZARO			7.25
00604369	ERIN JOHNSON			50.00
00604370	CLAUDIA RIDGLEY			125.00
00604371	MICHELE STABEN			195.00
00604372	M & L SUPPLY CO INC			529.12
00604373	NEALTON INC			177.13
00604374	CSWW INC			765.35
00604375	O'REILLY AUTOMOTIVE STORES I			30.91
00604376	SPOKANE CITY TREASURER			6,027.55
00604421	AFFORDABLE ASBESTOS ABATEMEN	359.70		
00604422	JOSE A CARRANZA	108.15		
00604423	CENTURYLINK	236.84		
00604424	HIP OF SPOKANE COUNTY DBA	62,778.20		
00604425	GAFFANEY ELECTRIC	40.00		
00604426	DAVID HILPERT	36.22		
00604427	DREW AND SARA FERGUSON	119.00		
00604428	GARLAND & MARKET INVESTOR	677.14		
00604429	MARGUERITE CLARITY	135.78		
00604430	NUKEY REALTY	115.29		
00604431	THOMPSON TILE	1,383.23		
00604432	JHAB3 CO	5,265.43		
00604433	OXFORD HOUSE HILLYARD	900.00		
00604434	POINTE PEST CONTROL	1,613.20		
00604435	SAFETY KLEEN CORPORATION	458.10		
00604436	SPOKANE CITY TREASURER	4,388.22		
00604437	CENTURYLINK COMMUNICATIONS I			516.07
00604438	SPOKANE UNITED METHODIST HOM	9,363.71		
00604439	SPOKANE CITY TREASURER OR	527,435.73		
00604440	SPOKANE LIFELINE INC	21.80		
00604441	SULLIVAN VENTURES, LLC	7,460.00		
00604442	CENTER POINT PUBLISHING INC		98.28	
00604443	Hannah Charlton		60.00	
00604444	Joni Michels		130.87	
00604445	Carl Richardson		100.00	
00604446	MOBIUS SPOKANE		675.00	
00604447	TK ELEVATOR CORPORATION		2,896.45	
00604448	WA STATE DEPT OF REVENUE			175,274.57
00604449	PRORATE AND FUEL TAX	1,054.00		
70000403	NORTHWEST INDUSTRIAL SERVICE			1,885.00
70000404	NORTHWEST INDUSTRIAL SERVICE	2,104.59		
70000405	CINTAS CORPORATION	2,764.95		
70000406	ELJAY OIL CO INC	1,303.26		
70000407	ENDRESS+HAUSER INC	2,273.57		
70000408	MIDLAND SCIENTIFIC INC	3,530.55		
70000409	POLYDYNE INC	22,930.88		
70000410	ALASKA RUBBER GROUP INC			14.82
70000411	CINTAS CORPORATION	5,802.46		
70000412	ELJAY OIL CO INC	840.67		
70000413	GALLS LLC			411.08
70000414	HORIZON DISTRIBUTORS			1,859.76

REPORT: PG3640
SYSTEM: FMSAP
USER: MANAGER
RUN NO: 29

CITY OF SPOKANE
COUNCIL CHECK RANGE/TOTAL

DATE: 07/22/24
TIME: 07:15
PAGE: 3

CHECK #	VENDOR	CITY	LIBRARY	PARKS
70000415	NORCO INC			91.07

70000416	OXARC INC		14.38
70000417	PEROVICH PARTNERS INC	3,633.60	
70000418	WESTERN STATES EQUIPMENT CO	107,149.18	
70000419	ALASKA RUBBER GROUP INC	460.49	
70000420	FLEET PAINTING INC	4,675.01	
70000421	GALLS LLC	840.42	
70000422	GORDON TRUCK CENTERS INC DBA	3,793.68	
70000423	SIGNS FOR SUCCESS INC	894.97	
70000424	CINTAS CORPORATION		76.30
70000425	EVERGREEN STATE TOWING LLC	2,006.69	
70000426	OVERDRIVE INC		10,049.21
70000427	SPOKANE TRANSIT AUTHORITY	3,841.54	
80131457	ACCESS INFORMATION HOLDINGS	4,086.17	
80131458	AHBL INC		35,344.33
80131459	ALSCO DIVISION OF ALSCO INC		412.42
80131460	THE FA BARTLETT TREE EXPERT		1,319.60
80131461	BI INC	23,115.30	
80131462	CLUB PROPHET SYSTEMS		1,220.80
80131463	COPIERS NORTHWEST INC		239.72
80131464	COYLE OUTSIDE LLC		3,920.00
80131465	DESAUTEL HEGE COMMUNICATIONS		1,310.00
80131466	DESIGN WEST ARCHITECTS PA	56,511.00	
80131467	DEVRIES INFORMATION MANAGEME		25.65
80131468	GORLEY LOGISTICS LLC		58.22
80131469	FIREPOWER INC		327.00
80131470	FOWLER UNITED METHODIST CHUR		1,500.00
80131471	FRIENDS OF MMOFRA		2,880.00
80131472	HILLYARD SENIOR ACTIVITY CTR		6,666.66
80131473	MARTIN LUTHER KING JR FAMILY		3,483.33
80131474	MID CITY CONCERNS INC		1,543.75
80131475	NORTHEAST YOUTH CENTER		11,628.17
80131476	PROJECT JOY		2,580.83
80131477	SINTO SENIOR CENTER		6,434.17
80131478	SOUTHSIDE SENIOR & COMMUNITY		7,736.84
80131479	SOUTHWEST SPOKANE COMMUNITY		3,488.50
80131480	THE HUNTINGTON NATIONAL BANK		195,404.25
80131481	VIP PRODUCTION NORTHWEST INC		5,308.85
80131482	WEST CENTRAL COMMUNITY		6,056.25
80131483	ABM JANITORIAL SERVICES SOUT	1,990.29	
80131484	ACRANET CBS BRANCH/DIV OF	38.00	
80131485	ALL SERVICE WEST TOWING	207.65	
80131486	ALS LABORATORY GROUP	290.00	
80131487	ALSCO DIVISION OF ALSCO INC	34.61	
80131488	ANYTIME TOWING & RECOVERY	138.43	
80131489	ASPEN AERIALS INC	29.67	
80131490	AVISTA UTILITIES	381,651.52	
80131491	BANNER FURNACE & FUEL	168.95	
80131492	BEARING DISTRIBUTORS INC	625.88	
80131493	CAMTEK INC	10,139.71	
80131494	CDW GOVERNMENT INC	2,285.39	
80131495	COLEMAN OIL COMPANY LLC	15,396.69	
80131496	CONNELL OIL INC	201.13	

REPORT: PG3640
SYSTEM: FMSAP
USER: MANAGER
RUN NO: 29

CITY OF SPOKANE
COUNCIL CHECK RANGE/TOTAL

DATE: 07/22/24
TIME: 07:15
PAGE: 4

CHECK #	VENDOR	CITY	LIBRARY	PARKS
80131497	CONSOLIDATED SUPPLY CO	78,531.61		
80131498	COPIERS NORTHWEST INC	66.70		
80131499	DEVRIES INFORMATION MANAGEME	153.90		
80131500	DOWL LLC	10,027.02		
80131501	ENTERPRISE FM TRUST	10,158.35		

80131502	FIREPOWER INC	408.76	
80131503	GE GRID SOLUTIONS LLC	4,925.76	
80131504	HALME CONSTRUCTION INC	10,290.85	
80131505	HASA INC	15,509.87	
80131506	INLAND ENVIRONMENTAL RESOURC	7,838.74	
80131507	KPFF CONSULTING ENGINEERS	7,266.29	
80131508	LSB CONSULTING ENGINEERS PLL	56,975.87	
80131509	NEPTUNE TECHNOLOGY GROUP INC	153.29	
80131510	NORTHSTAR CHEMICAL INC	3,539.97	
80131511	PARAMETRIX INC	35,543.79	
80131512	PETE LIEN & SONS INC	33,908.76	
80131513	SPOKANE COUNTY TITLE CO	1,723.29	
80131514	SPOKANE INT'L AIRPORT	180.00	
80131515	VERIZON WIRELESS	1,241.27	
80131516	VERIZON WIRELESS LERT B	50.00	
80131517	CHRISTOPHER BOVEY		2,805.00
80131518	STEPHANIE SIJOHN	100.00	
80131519	ACTION MATERIALS		843.42
80131520	ARROW CONSTRUCTION SUPPLY IN		358.52
80131521	AVISTA CORPORATION	9,912.40	
80131522	AVISTA UTILITIES		44.74
80131523	BATTERY SYSTEMS INC		120.34
80131524	RODNEY D SANKEY dba	415.29	
80131525	CAMTEK INC	7,010.83	
80131526	CLARY LONGVIEW LLC	98,893.86	
80131527	COLEMAN OIL COMPANY LLC	3,090.41	
80131528	COLUMBIA ELECTRIC SUPPLY/DIV	7,459.44	
80131529	CONSOLIDATED ELECTRICAL		103.46
80131530	COPIERS NORTHWEST INC	4,040.07	
80131531	COPPER STATE BOLT & NUT CO		119.00
80131532	CORE & MAIN LP	6,022.58	
80131533	CUESTA SPRINGS ICE COMPANY O	65.40	
80131534	DELL MARKETING LP	2,168.26	
80131535	DESAUTEL HEGE COMMUNICATIONS	49,140.00	
80131536	DEVRIES INFORMATION MANAGEME	68.40	
80131537	ECOICHEM ANALYTICS INC	3,233.08	
80131538	ELECTRONIC DATA COLLECTION	12,964.09	
80131539	ENTERPRISE FM TRUST		20,662.52
80131540	FASTENAL CO	1,945.90	1,395.83
80131541	GORLEY LOGISTICS LLC	24.95	
80131542	FRANCIS AVENUE HARDWARE		925.11
80131543	GOLF COURSE SUPERINTENDENT		465.00
80131544	GOODALE & BARBIERI COMPANY	2,500.00	
80131545	H D FOWLER COMPANY	32,471.87	
80131546	HOME DEPOT USA INC		952.93
80131547	INDUSTRIAL BOLT & SUPPLY INC		812.67
80131548	INLAND POWER & LIGHT CO		123.50
80131549	IMPERIAL BAG & PAPER CO LLC		459.44

REPORT: PG3640

CITY OF SPOKANE

DATE: 07/22/24

SYSTEM: FMSAP

COUNCIL CHECK RANGE/TOTAL

TIME: 07:15

USER: MANAGER

PAGE: 5

RUN NO: 29

CHECK #	VENDOR	CITY	LIBRARY	PARKS
80131550	INTERFAITH HOSPITALITY	145,556.25		
80131551	LANGUAGE LINE SERVICES	256.18		
80131552	MALLORY PAINT STORE INC			570.45
80131553	MCGUIRE BEARING CO			81.48
80131554	NAPA AUTO PARTS			27.09
80131555	CHARLES H NEU			268.10
80131556	NORLIFT INC			965.90
80131557	NW LANDSCAPE MAINTENANCE INC	112.29		
80131558	PACIFIC GOLF TURF LLC			81.94

80131559	PETE LIEN & SONS INC	10,924.98	
80131560	PIONEER HUMAN SERVICES	1,968.57	
80131561	PREMERA BLUE CROSS OR	877,924.76	
80131562	RHODES CRANE & RIGGING INC	1,154.75	
80131563	RIVER PARK SQUARE LLC	162.50	
80131564	THE SALVATION ARMY	702,106.86	
80131565	SHAMROCK PAVING CO/DIV OF	5,222.68	
80131566	SHI CORP	1,088.48	
80131567	SPOKANE NEIGHBORHOOD ACTION	101,420.81	
80131568	SPOKANE COUNTY TREASURER	3,111.58	
80131569	COWLES PUBLISHING COMPANY	702.75	
80131570	STANTEC CONSULTING SERVICES	27,754.24	
80131571	STARPLEX CORP	3,564.00	
80131572	STELLAR INDUSTRIAL SUPPLY IN	523.71	
80131573	TRUTH MINISTRIES OF SPOKANE	52,900.87	
80131574	VERIZON WIRELESS	4,028.46	
80131575	VOLUNTEERS OF AMERICA OF	87,417.68	
80131576	WILDROSE LTD dba		291.03
80131577	HOWARD F DELANEY	160.00	
80131578	ED HAIGHT SERVICE	208.41	
80131579	NIKKI HANSHAW	49.65	
80131580	JEFF C HUMPHREY	74.44	
80131581	ROBERT MOORE	11.06	
80131582	KRISTIN O'SULLIVAN	115.00	
80131583	ABM JANITORIAL SERVICES SOUT	2,169.36	
80131584	ACRANET CBS BRANCH/DIV OF	1,340.50	
80131585	ALSCO DIVISION OF ALSCO INC	68.23	4.58
80131586	AVISTA UTILITIES	187,613.81	
80131587	BUDINGER & ASSOCIATES INC	11,118.85	
80131588	CAMTEK INC	3,662.40	
80131589	COFFMAN ENGINEERS INC		14,762.50
80131590	COLEMAN OIL COMPANY LLC	42,911.25	
80131591	COMPUNET INC	4,264.80	
80131592	CONNELL OIL INC	403.94	
80131593	STEVE CONNER		23,668.37
80131594	CONTROL SOLUTIONS NW INC	87,892.20	
80131595	COPIERS NORTHWEST INC	1,942.43	1,995.35
80131596	CORBIN SENIOR ACTIVITY CENTE		2,612.50
80131597	CREEK AT QUALCHAN GOLF COURS		19,431.82
80131598	L N CURTIS & SONS	6,171.20	
80131599	DELL MARKETING LP	20,951.34	
80131600	DW EXCAVATING INC	384,516.50	
80131601	ENVIRONMENT CONTROL OF SPOKA	6,428.80	
80131603	FASTENAL CO	1,911.64	

REPORT: PG3640
SYSTEM: FMSAP
USER: MANAGER
RUN NO: 29

CITY OF SPOKANE
COUNCIL CHECK RANGE/TOTAL

DATE: 07/22/24
TIME: 07:15
PAGE: 6

CHECK #	VENDOR	CITY	LIBRARY	PARKS
80131604	FOUR SEASONS SERVICES INC	4,806.90		
80131605	HOTSY OF SPOKANE LLC	16,605.25		
80131606	KENWORTH SALES COMPANY	1,749.15		
80131607	LARIVIERE INC	30,735.15		
80131608	MEGA WASH LLC	5,162.16		
80131609	NORTHWEST RIVER SUPPLIES INC	1,249.14		
80131610	PARAMETRIX INC	6,145.00		
80131611	PROCLAIM LIBERTY INC	460,309.33		
80131612	PYRO SPECTACULARS NORTH INC			20,000.00
80131613	SAJB-WELLHEAD IMPLEMENTATION	25,000.00		
80131614	SANDBAGGERS CLUB LLC			16,081.76
80131615	VIRGINIA M SCUDDER	3,750.00		
80131616	SPOKANE TREATMENT AND	9,841.69		

80131617	W B SPRAGUE COMPANY INC		57.68
80131618	SPOKANE SOFTBALL UMPIRE ASSO		7,491.90
80131619	T BAILEY INC	281,435.67	
80131620	T & T GOLF MANAGEMENT INC		23,086.69
80131621	US BANK OR CITY TREASURER	38,730.28	
80131622	US TESTING EQUIPMENT LTD		2,640.44
80131623	VERIZON WIRELESS	360.09	
80131624	TODD MENIER	775.00	
80131625	2B PROPERTIES LLC	1,500.00	
80131626	AVISTA UTILITIES		7,554.43
80131627	BACON CONCRETE INC	38,552.11	
80131628	BAKER & TAYLOR BOOKS		5,298.77
80131629	CHARLES R DELGADO	1,404.00	
80131630	DELTA DENTAL OF WASHINGTON	42,954.82	
80131631	EXPRESS NAME TAGS & MORE, IN		19.45
80131632	GRAINGER INC		41.97
80131633	HILL INTERNATIONAL INC		3,439.91
80131634	IBEX FLOORING LLC	22,263.25	
80131635	KATHERINE MACKENZIE STUART D		100.00
80131636	INGRAM LIBRARY SERVICES LLC		1,196.15
80131637	KAISER FOUNDATION HEALTH PLA	151,358.52	
80131638	KRUEGER SHEET METAL COMPANY	26,754.05	
80131639	LYNDA CARPENTER	211.25	
80131640	MDM CONSTRUCTION GROUP INC	582,481.80	
80131641	MIDWEST TAPE		338.70
80131642	MK SOLUTIONS INC		686.70
80131643	NOVUS AUTO GLASS	811.75	
80131644	ORBIS CASCADE ALLIANCE		2,098.00
80131645	PROVOST PROFESSIONAL	2,245.69	
80131646	SOLID WASTE SYSTEMS INC	83,979.09	
80131647	SPOKANE COUNTY TREASURER	62,883.21	
80131648	SPOKANE HARDWARE SUPPLY INC		2,051.51
80131649	TOBY'S BODY & FENDER INC	7,403.90	
80131650	ULINE INC		1,139.40
80131651	UNITED LABORATORIES INC		310.92
80131652	US BANK TRAVEL CARD	74,359.41	
80131653	RUSTY J BOICOURT DBA VERITAS	9,930.00	
80131654	VERIZON WIRELESS	678.38	
80131655	CATHERINE G BAKKEN		177.65
80131656	GINA COOPER		13.99

REPORT: PG3640
SYSTEM: FMSAP
USER: MANAGER
RUN NO: 29

CITY OF SPOKANE
COUNCIL CHECK RANGE/TOTAL

DATE: 07/22/24
TIME: 07:15
PAGE: 7

CHECK #	VENDOR	CITY	LIBRARY	PARKS
80131657	LAUREN HAYES		48.58	
80131658	JUAN JUAN MOSES		535.61	
80131659	ALINA MURCAR		12.73	
80131660	STEVEN PECK		75.00	
		6,815,535.78	39,234.42	677,316.70
				=====
		CITYWIDE TOTAL:		7,532,086.90

REPORT: PG3630
SYSTEM: FMSAP
USER: MANAGER
RUN NO: 29

DATE: 07/22/24
TIME:
PAGE: 1

HONORABLE MAYOR
AND COUNCIL MEMBERS

07/22/24
PAGE 2

PROCESSING OF VOUCHERS RESULTS IN CLAIMS AS FOLLOWS:

0020 - NONDEPARTMENTAL

SPOKANE TRANSIT AUTHORITY	CONTRACTUAL SERVICES	
	CREDIT CARD PMT NO. - 70000427	3,841.54
SPOKANE TREATMENT AND	CONTRACTUAL SERVICES	
RECOVERY SERVICES	ACH PMT NO. - 80131616	9,841.69
TOTAL FOR 0020 - NONDEPARTMENTAL		----- 13,683.23

0030 - POLICE OMBUDSMAN

COPIERS NORTHWEST INC	MISC SERVICES/CHARGES	
	ACH PMT NO. - 80131530	172.07
US BANK TRAVEL CARD	REGISTRATION/SCHOOLING	
	ACH PMT NO. - 80131652	1,585.00
TOTAL FOR 0030 - POLICE OMBUDSMAN		----- 1,757.07

0100 - GENERAL FUND

STANTEC CONSULTING SERVICES	GRANT CASH PASS THRU ACCOUNT	
INC	ACH PMT NO. - 80131570	27,754.24
US BANK TRAVEL CARD	GRANT CASH PASS THRU ACCOUNT	
	ACH PMT NO. - 80131652	11,648.73
WA STATE DEPT OF REVENUE	DEPOSIT-LEASE EXCISE TAX	
MISCELLANEOUS TAX DIVISION	CHECK NO. - 00604358	15,772.08
TOTAL FOR 0100 - GENERAL FUND		----- 55,175.05

0230 - CIVIL SERVICE

DELL MARKETING LP	COMPUTERS	
%DELL USA LP	ACH PMT NO. - 80131599	4,187.51
DEVRIES INFORMATION MANAGEMENT	MISC SERVICES/CHARGES	
	ACH PMT NO. - 80131536	8.55
US BANK TRAVEL CARD	LODGING	
	ACH PMT NO. - 80131652	3,496.61
TOTAL FOR 0230 - CIVIL SERVICE		----- 7,692.67

0260 - CITY CLERK

ACCESS INFORMATION HOLDINGS	CONTRACTUAL SERVICES	
	ACH PMT NO. - 80131457	4,086.17

HONORABLE MAYOR
AND COUNCIL MEMBERS

07/22/24
PAGE 3

PROCESSING OF VOUCHERS RESULTS IN CLAIMS AS FOLLOWS:

DEVRIES INFORMATION MANAGEMENT	MISC SERVICES/CHARGES	
	ACH PMT NO. - 80131499	8.55

TOTAL FOR 0260 - CITY CLERK 4,094.72

0320 - COUNCIL

US BANK TRAVEL CARD AIRFARE ACH PMT NO. - 80131652 1,664.76

US BANK TRAVEL CARD REGISTRATION/SCHOOLING ACH PMT NO. - 80131652 2,500.00

TOTAL FOR 0320 - COUNCIL 4,164.76

0330 - PUBLIC AFFAIRS/COMMUNICATIONS

ERIC P THOMPSON LOCAL MILEAGE CHECK NO. - 00604354 110.42

JEFF C HUMPHREY LOCAL MILEAGE ACH PMT NO. - 80131580 74.44

VERIZON WIRELESS CELL PHONE ACH PMT NO. - 80131654 336.46

TOTAL FOR 0330 - PUBLIC AFFAIRS/COMMUNICATIONS 521.32

0370 - ENGINEERING SERVICES

AVISTA UTILITIES UTILITY LIGHT/POWER SERVICE ACH PMT NO. - 80131586 691.35

COPIERS NORTHWEST INC OPERATING RENTALS/LEASES ACH PMT NO. - 80131595 845.98

DELL MARKETING LP COMPUTERS %DELL USA LP ACH PMT NO. - 80131534 2,168.26

ENTERPRISE FM TRUST OPERATING RENTALS/LEASES ATTN: CUSTOMER BILLING ACH PMT NO. - 80131501 2,231.63

WATERCO OF THE PACIFIC NORTH OPERATING SUPPLIES WEST, INC CHECK NO. - 00604317 76.04

TOTAL FOR 0370 - ENGINEERING SERVICES 6,013.26

0410 - FINANCE

SPOKANE COUNTY TREASURER CONTRACTUAL SERVICES ACH PMT NO. - 80131647 62,883.21

HONORABLE MAYOR AND COUNCIL MEMBERS 07/22/24 PAGE 4

PROCESSING OF VOUCHERS RESULTS IN CLAIMS AS FOLLOWS:

TOTAL FOR 0410 - FINANCE 62,883.21

0450 - NEIGHBHD HOUSING HUMAN SVCS

VERIZON WIRELESS CELL PHONE

ACH PMT NO. - 80131574 85.48

TOTAL FOR 0450 - NEIGHBHD HOUSING HUMAN SVCS 85.48

0480 - OFFICE OF CIVIL RIGHTS

VERIZON WIRELESS CELL PHONE ACH PMT NO. - 80131654 85.48

TOTAL FOR 0480 - OFFICE OF CIVIL RIGHTS 85.48

0500 - LEGAL

DEVRIES INFORMATION MANAGEMENT MISC SERVICES/CHARGES ACH PMT NO. - 80131536 51.30

GORLEY LOGISTICS LLC OPERATING SUPPLIES dba FIKES NORTHWEST ACH PMT NO. - 80131541 24.95

SPOKANE COUNTY TREASURER TELEPHONE ACH PMT NO. - 80131568 56.64

US BANK TRAVEL CARD AIRFARE ACH PMT NO. - 80131652 493.75

VERIZON WIRELESS CELL PHONE ACH PMT NO. - 80131574 104.27

TOTAL FOR 0500 - LEGAL 730.91

0520 - MAYOR

COPIERS NORTHWEST INC OPERATING RENTALS/LEASES ACH PMT NO. - 80131595 140.81

DESAUTEL HEGE COMMUNICATIONS CONTRACTUAL SERVICES INC ACH PMT NO. - 80131535 49,140.00

DEVRIES INFORMATION MANAGEMENT CONTRACTUAL SERVICES ACH PMT NO. - 80131536 8.55

VERIZON WIRELESS CELL PHONE ACH PMT NO. - 80131654 299.18

TOTAL FOR 0520 - MAYOR 49,588.54

HONORABLE MAYOR AND COUNCIL MEMBERS

07/22/24 PAGE 5

PROCESSING OF VOUCHERS RESULTS IN CLAIMS AS FOLLOWS:

0560 - MUNICIPAL COURT

COMPUNET INC MINOR EQUIPMENT LB 410802 ACH PMT NO. - 80131591 4,264.80

COPIERS NORTHWEST INC OPERATING RENTALS/LEASES ACH PMT NO. - 80131530 1,587.24

HOWARD F DELANEY OTHER TRANSPORTATION EXPENSES ACH PMT NO. - 80131577 45.00

HOWARD F DELANEY	PER DIEM ACH PMT NO. - 80131577	115.00
KRISTIN O'SULLIVAN	PER DIEM ACH PMT NO. - 80131582	115.00
RIVER PARK SQUARE LLC	PARKING/TOLLS (LOCAL) ACH PMT NO. - 80131563	162.50
US BANK TRAVEL CARD	AIRFARE ACH PMT NO. - 80131652	228.11
US BANK TRAVEL CARD	LODGING ACH PMT NO. - 80131652	467.55
TOTAL FOR 0560 - MUNICIPAL COURT		6,985.20

0620 - HUMAN RESOURCES

VERIZON WIRELESS	CELL PHONE ACH PMT NO. - 80131574	335.27
TOTAL FOR 0620 - HUMAN RESOURCES		335.27

0680 - POLICE

ACRANET CBS BRANCH/DIV OF CBS REPORTING INC	BACKGROUND CHECKS ACH PMT NO. - 80131484	38.00
ALL SERVICE WEST TOWING	TOWING EXPENSE ACH PMT NO. - 80131485	207.65
ANYTIME TOWING & RECOVERY	TOWING EXPENSE ACH PMT NO. - 80131488	138.43
CDW GOVERNMENT INC	OFFICE SUPPLIES ACH PMT NO. - 80131494	2,116.67
CDW GOVERNMENT INC	OPERATING SUPPLIES ACH PMT NO. - 80131494	168.72
CENTURYLINK	ALARM/SECURITY SERVICES CHECK NO. - 00604315	313.54

HONORABLE MAYOR
AND COUNCIL MEMBERS

07/22/24
PAGE 6

PROCESSING OF VOUCHERS RESULTS IN CLAIMS AS FOLLOWS:

CENTURYLINK	TELEPHONE CHECK NO. - 00604315	636.96
COPIERS NORTHWEST INC	EQUIPMENT REPAIRS/MAINTENANCE ACH PMT NO. - 80131498	66.70
DEVRIES INFORMATION MANAGEMENT	MISC SERVICES/CHARGES ACH PMT NO. - 80131499	145.35
FIREPOWER INC	ALARM/SECURITY SERVICES ACH PMT NO. - 80131502	408.76
FOUR SEASONS SERVICES INC DBA FOUR SEASONS LANDSCAPING	LANDSCAPE/GROUNDS MAINT ACH PMT NO. - 80131604	4,806.90

GALLS LLC	CLOTHING CREDIT CARD PMT NO. - 70000421	840.42
NORTHWEST INDUSTRIAL SERVICES DBA AMERICAN ON SITE SERVICES	OPERATING RENTALS/LEASES CREDIT CARD PMT NO. - 70000404	220.00
RODNEY D SANKEY dba BULLDOG TOWING LLC	TOWING EXPENSE ACH PMT NO. - 80131524	415.29
SPOKANE TEACHERS CREDIT UNION	MISC SERVICES/CHARGES CHECK NO. - 00604321	37.50
US BANK TRAVEL CARD	AIRFARE ACH PMT NO. - 80131652	2,981.73
US BANK TRAVEL CARD	LODGING ACH PMT NO. - 80131652	18,280.55
US BANK TRAVEL CARD	OTHER TRANSPORTATION EXPENSES ACH PMT NO. - 80131652	3,537.06
US BANK TRAVEL CARD	PER DIEM ACH PMT NO. - 80131652	24.86
US BANK TRAVEL CARD	REGISTRATION/SCHOOLING ACH PMT NO. - 80131652	17,057.00
VERIZON WIRELESS LERT B	MISC SERVICES/CHARGES ACH PMT NO. - 80131516	50.00

TOTAL FOR 0680 - POLICE	52,492.09
-------------------------	-----------

0690 - COMMUNITY JUSTICE SERVICES

COPIERS NORTHWEST INC	OPERATING RENTALS/LEASES ACH PMT NO. - 80131530	471.80
-----------------------	--	--------

TOTAL FOR 0690 - COMMUNITY JUSTICE SERVICES	471.80
---	--------

0700 - PUBLIC DEFENDER

HONORABLE MAYOR
AND COUNCIL MEMBERS

07/22/24
PAGE 7

PROCESSING OF VOUCHERS RESULTS IN CLAIMS AS FOLLOWS:

CHARLES R DELGADO DBA DELGADO INVESTIGATIONS LLC	LEGAL SERVICES ACH PMT NO. - 80131629	1,404.00
LYNDA CARPENTER DBA LC INVESTIGATIONS LLC	LEGAL SERVICES ACH PMT NO. - 80131639	211.25
PROVOST PROFESSIONAL INVESTIGATIONS	LEGAL SERVICES ACH PMT NO. - 80131645	2,245.69
US BANK TRAVEL CARD	PER DIEM ACH PMT NO. - 80131652	36.25

TOTAL FOR 0700 - PUBLIC DEFENDER	3,897.19
----------------------------------	----------

1100 - STREET FUND

2B PROPERTIES LLC	RIGHT OF WAY
-------------------	--------------

	ACH PMT NO. - 80131625	1,500.00
AVISTA UTILITIES	UTILITY LIGHT/POWER SERVICE	
	ACH PMT NO. - 80131490	209,824.99
CENTURYLINK	TELEPHONE	
	CHECK NO. - 00604315	230.54
KAISER FOUNDATION HEALTH OF WASHINGTON	MEDICAL SERVICES	
	CHECK NO. - 00604335	1,414.00
NORTHWEST INDUSTRIAL SERVICES DBA AMERICAN ON SITE SERVICES	OPERATING RENTALS/LEASES	
	CREDIT CARD PMT NO. - 70000404	210.00
SHAMROCK PAVING CO/DIV OF MURPHY BROS INC	REPAIR & MAINTENANCE SUPPLIES	
	ACH PMT NO. - 80131565	5,222.68
TOTAL FOR 1100 - STREET FUND		----- 218,402.21

1200 - CODE ENFORCEMENT FUND

AFFORDABLE ASBESTOS ABATEMENT OF SPOKANE LLC	CONTRACTUAL SERVICES	
	CHECK NO. - 00604421	359.70
ENTERPRISE FM TRUST ATTN: CUSTOMER BILLING	OPERATING RENTALS/LEASES	
	ACH PMT NO. - 80131501	1,302.70
SPOKANE COUNTY TREASURER	CONTRACTUAL SERVICES	
	ACH PMT NO. - 80131568	3,054.94
TOTAL FOR 1200 - CODE ENFORCEMENT FUND		----- 4,717.34

1360 - MISCELLANEOUS GRANTS FUND

OXFORD HOUSE HILLYARD	OTHER MISC CHARGES	
	CHECK NO. - 00604433	900.00

HONORABLE MAYOR
AND COUNCIL MEMBERS

07/22/24
PAGE 8

PROCESSING OF VOUCHERS RESULTS IN CLAIMS AS FOLLOWS:

STANTEC CONSULTING SERVICES INC	CONTRACTUAL SERVICES	
	ACH PMT NO. - 80131570	27,754.24
STANTEC CONSULTING SERVICES INC	GRANT CASH PASS THRU ACCOUNT	
	ACH PMT NO. - 80131570	27,754.24-
US BANK TRAVEL CARD	GRANT CASH PASS THRU ACCOUNT	
	ACH PMT NO. - 80131652	11,648.73-
US BANK TRAVEL CARD	OPERATIONAL TRAVEL	
	ACH PMT NO. - 80131652	11,648.73
TOTAL FOR 1360 - MISCELLANEOUS GRANTS FUND		----- 900.00

1380 - TRAFFIC CALMING MEASURES

CURTIS MCSPADEN 3221 E 16TH AVE	SCHOOL ZONE SPEED CAMERA FINE	
	CHECK NO. - 00604343	460.00
DEBORAH CAMARDA 9020 S CHENEY SPOKANE RD	SCHOOL ZONE SPEED CAMERA FINE	
	CHECK NO. - 00604344	375.00

DOWL LLC	CONTRACTUAL SERVICES ACH PMT NO. - 80131500	6,174.58
JOSHUA KABWE 329 E WABASH AVE	SCHOOL ZONE SPEED CAMERA FINE CHECK NO. - 00604345	305.00
LACY WOOD 906 E RICH AVE	SCHOOL ZONE SPEED CAMERA FINE CHECK NO. - 00604346	311.71
PAUL MCARTHUR 6607 S WANETA RD	SCHOOL ZONE SPEED CAMERA FINE CHECK NO. - 00604347	243.00
TOTAL FOR 1380 - TRAFFIC CALMING MEASURES		7,869.29

1400 - PARKS AND RECREATION FUND

ACRANET CBS BRANCH/DIV OF CBS REPORTING INC	BACKGROUND CHECKS ACH PMT NO. - 80131584	1,224.00
US BANK TRAVEL CARD	AIRFARE ACH PMT NO. - 80131652	249.95
US BANK TRAVEL CARD	LODGING ACH PMT NO. - 80131652	6,043.59
US BANK TRAVEL CARD	OPERATIONAL TRAVEL ACH PMT NO. - 80131652	904.92
US BANK TRAVEL CARD	OTHER TRANSPORTATION EXPENSES ACH PMT NO. - 80131652	325.69
TOTAL FOR 1400 - PARKS AND RECREATION FUND		8,748.15

HONORABLE MAYOR
AND COUNCIL MEMBERS

07/22/24
PAGE 9

PROCESSING OF VOUCHERS RESULTS IN CLAIMS AS FOLLOWS:

1425 - AMERICAN RESCUE PLAN

HIP OF SPOKANE COUNTY DBA COMMUNITY MINDED ENTERPRISES	CONTRACTUAL SERVICES CHECK NO. - 00604424	62,778.20
KATHLEEN LANIER 7565 SHADOW HILLS DRIVE	RECRUITMENT TRAVEL EXPENSE CHECK NO. - 00604350	1,132.70
KEVIN HALL 4391 N BIDAHOCHI DR	RECRUITMENT TRAVEL EXPENSE CHECK NO. - 00604349	1,132.70
MATTHEW MURRAY 102 N 24TH AVE	RECRUITMENT TRAVEL EXPENSE CHECK NO. - 00604351	980.25
NUMERICA CREDIT UNION	CONTRACTUAL SERVICES CHECK NO. - 00604311	111,136.58
TOM WORTHY 2869 NE KELLY PLACE	RECRUITMENT TRAVEL EXPENSE CHECK NO. - 00604348	1,263.99
US BANK TRAVEL CARD	RECRUITMENT TRAVEL EXPENSE ACH PMT NO. - 80131652	1,572.91
TOTAL FOR 1425 - AMERICAN RESCUE PLAN		179,997.33

1460 - PARKING METER REVENUE FUND

ELECTRONIC DATA COLLECTION CORPORATION	POSTAGE ACH PMT NO. - 80131538	177.42
ELECTRONIC DATA COLLECTION CORPORATION	PRINTING/BINDING/REPRO ACH PMT NO. - 80131538	186.00
ELECTRONIC DATA COLLECTION CORPORATION	SUBSCRIPTION BASED IT ARNGMTS ACH PMT NO. - 80131538	12,600.67
PEROVICH PARTNERS INC dba SPEEDPRO IMAGING	OPERATING SUPPLIES CREDIT CARD PMT NO. - 70000417	3,633.60
VERIZON WIRELESS	CELL PHONE ACH PMT NO. - 80131574	512.88
VERIZON WIRELESS	IT/DATA SERVICES ACH PMT NO. - 80131574	240.06
TOTAL FOR 1460 - PARKING METER REVENUE FUND		17,350.63

1560 - FORFEITURES & CONTRIBUTION FND

ABM JANITORIAL SERVICES SOUTH SOUTH CENTRAL INC dba	LAUNDRY/JANITORIAL SERVICES ACH PMT NO. - 80131483	1,990.29
SPOKANE COUNTY TITLE CO	LEGAL SERVICES ACH PMT NO. - 80131513	1,723.29

HONORABLE MAYOR
AND COUNCIL MEMBERS

07/22/24
PAGE 10

PROCESSING OF VOUCHERS RESULTS IN CLAIMS AS FOLLOWS:

TOTAL FOR 1560 - FORFEITURES & CONTRIBUTION FND	3,713.58
---	----------

1640 - COMMUNICATIONS BLDG M&O FUND

CENTURYLINK	TELEPHONE CHECK NO. - 00604423	236.84
ENVIRONMENT CONTROL OF SPOKANE	LAUNDRY/JANITORIAL SERVICES ACH PMT NO. - 80131601	2,525.60
SPOKANE CITY TREASURER	PUBLIC UTILITY SERVICE CHECK NO. - 00604436	2,618.69
TOTAL FOR 1640 - COMMUNICATIONS BLDG M&O FUND		5,381.13

1680 - CD/HS OPERATIONS

ACRANET CBS BRANCH/DIV OF CBS REPORTING INC	BACKGROUND CHECKS ACH PMT NO. - 80131584	52.50
DELL MARKETING LP %DELL USA LP	MINOR EQUIPMENT ACH PMT NO. - 80131599	8,205.80
TOTAL FOR 1680 - CD/HS OPERATIONS		8,258.30

1910 - CRIMINAL JUSTICE ASSISTANCE FD

BI INC	PROFESSIONAL SERVICES ACH PMT NO. - 80131461	23,115.30
LANGUAGE LINE SERVICES LANGUAGE LINE LLC	INTERPRETER COSTS ACH PMT NO. - 80131551	256.18
VIRGINIA M SCUDDER	INTERPRETER COSTS ACH PMT NO. - 80131615	3,750.00
TOTAL FOR 1910 - CRIMINAL JUSTICE ASSISTANCE FD		27,121.48

1970 - FIRE/EMS FUND

ALASKA RUBBER GROUP INC DBA ARG INDUSTRIAL	REPAIR & MAINTENANCE SUPPLIES CREDIT CARD PMT NO. - 70000419	129.99
ALASKA RUBBER GROUP INC DBA ARG INDUSTRIAL	VEHICLE REPAIR & MAINT SUPPLY CREDIT CARD PMT NO. - 70000419	330.50
ALSCO DIVISION OF ALSCO INC	LAUNDRY/JANITORIAL SERVICES ACH PMT NO. - 80131585	102.84
BOUND TREE MEDICAL LLC	SAFETY SUPPLIES CHECK NO. - 00604314	542.97

HONORABLE MAYOR
AND COUNCIL MEMBERS

07/22/24
PAGE 11

PROCESSING OF VOUCHERS RESULTS IN CLAIMS AS FOLLOWS:

CLARY LONGVIEW LLC DBA BUD CLARY FORD/HYUNDAI	VEHICLES ACH PMT NO. - 80131526	98,893.86
COLEMAN OIL COMPANY LLC	MOTOR FUEL-OUTSIDE VENDOR ACH PMT NO. - 80131495	12,460.01
ENVIRONMENT CONTROL OF SPOKANE	LAUNDRY/JANITORIAL SERVICES ACH PMT NO. - 80131601	3,903.20
FASTENAL CO	OPERATING SUPPLIES ACH PMT NO. - 80131603	1,205.66
FASTENAL CO	REPAIR & MAINTENANCE SUPPLIES ACH PMT NO. - 80131603	506.10
FASTENAL CO	VEHICLE REPAIR & MAINT SUPPLY ACH PMT NO. - 80131603	199.88
NORTHWEST RIVER SUPPLIES INC	CLOTHING ALTERATIONS & REPAIRS ACH PMT NO. - 80131609	1,249.14
NW LANDSCAPE MAINTENANCE INC DBA DARNALL SPRINKLERS	BUILDING REPAIRS/MAINTENANCE ACH PMT NO. - 80131557	109.00
NW LANDSCAPE MAINTENANCE INC DBA DARNALL SPRINKLERS	REPAIR & MAINTENANCE SUPPLIES ACH PMT NO. - 80131557	3.29
POINTE PEST CONTROL	BUILDING REPAIRS/MAINTENANCE CHECK NO. - 00604434	147.15
SAFETY KLEEN CORPORATION	HAZARDOUS WASTE DISPOSAL CHECK NO. - 00604435	458.10
SIGNS FOR SUCCESS INC	VEHICLE REPAIR & MAINT SUPPLY CREDIT CARD PMT NO. - 70000423	894.97

SPOKANE CITY TREASURER	PUBLIC UTILITY SERVICE CHECK NO. - 00604436	1,769.53
US BANK TRAVEL CARD	LODGING ACH PMT NO. - 80131652	627.48
VERIZON WIRELESS	IT/DATA SERVICES ACH PMT NO. - 80131623	360.09
TOTAL FOR 1970 - FIRE/EMS FUND		----- 123,893.76
1980 - DEFINED CONTRIBUTION ADMIN FND		
US BANK TRAVEL CARD	AIRFARE ACH PMT NO. - 80131652	346.70
TOTAL FOR 1980 - DEFINED CONTRIBUTION ADMIN FND		----- 346.70
3160 - GENERAL CAPITAL IMPROVEMENTS		

HONORABLE MAYOR AND COUNCIL MEMBERS		07/22/24 PAGE 12
PROCESSING OF VOUCHERS RESULTS IN CLAIMS AS FOLLOWS:		
DESIGN WEST ARCHITECTS PA	CONSTRUCTION OF FIXED ASSETS ACH PMT NO. - 80131466	56,511.00
TOTAL FOR 3160 - GENERAL CAPITAL IMPROVEMENTS		----- 56,511.00
3200 - ARTERIAL STREET FUND		
BACON CONCRETE INC	CONSTRUCTION OF FIXED ASSETS ACH PMT NO. - 80131627	38,552.11
BUDINGER & ASSOCIATES INC	CONSTRUCTION OF FIXED ASSETS ACH PMT NO. - 80131587	7,179.21
DOWL LLC	CONSTRUCTION OF FIXED ASSETS ACH PMT NO. - 80131500	3,852.44
HALME CONSTRUCTION INC	CONSTRUCTION OF FIXED ASSETS ACH PMT NO. - 80131504	10,290.85
KPFF CONSULTING ENGINEERS	CONSTRUCTION OF FIXED ASSETS ACH PMT NO. - 80131507	7,266.29
MDM CONSTRUCTION GROUP INC	CONSTRUCTION OF FIXED ASSETS ACH PMT NO. - 80131640	455,681.46
PARAMETRIX INC	CONSTRUCTION OF FIXED ASSETS ACH PMT NO. - 80131610	40,378.79
STARPLEX CORP	CONSTRUCTION OF FIXED ASSETS ACH PMT NO. - 80131571	3,564.00
TOTAL FOR 3200 - ARTERIAL STREET FUND		----- 566,765.15
4100 - WATER DIVISION		

AVISTA UTILITIES	UTILITY LIGHT/POWER SERVICE ACH PMT NO. - 80131586	186,223.62
AVISTA UTILITIES	UTILITY NATURAL GAS ACH PMT NO. - 80131586	698.84
CAMTEK INC	CONTRACTUAL SERVICES ACH PMT NO. - 80131588	10,433.27
CINTAS CORPORATION	LAUNDRY/JANITORIAL SERVICES CREDIT CARD PMT NO. - 70000405	2,764.95
COPIERS NORTHWEST INC	MINOR EQUIPMENT ACH PMT NO. - 80131530	1,808.96
CORE & MAIN LP	INVENTORY PURCHASES FOR WATER ACH PMT NO. - 80131532	6,022.58
DAVID HILPERT 3646 LITTLE SWEDEN RD	REFUNDS CHECK NO. - 00604426	36.22

HONORABLE MAYOR
AND COUNCIL MEMBERS

07/22/24
PAGE 13

PROCESSING OF VOUCHERS RESULTS IN CLAIMS AS FOLLOWS:

DREW AND SARA FERGUSON PO BOX 1770	REFUNDS CHECK NO. - 00604427	79.00
ENTERPRISE FM TRUST ATTN: CUSTOMER BILLING	OPERATING RENTALS/LEASES ACH PMT NO. - 80131501	1,173.01
FASTENAL CO	REPAIR & MAINTENANCE SUPPLIES ACH PMT NO. - 80131540	212.62
GARLAND & MARKET INVESTOR 801 W RIVERSIDE AVE	REFUNDS CHECK NO. - 00604428	677.14
GE GRID SOLUTIONS LLC	CONSTRUCTION OF FIXED ASSETS ACH PMT NO. - 80131503	4,925.76
H D FOWLER COMPANY	INVENTORY PURCHASES FOR WATER ACH PMT NO. - 80131545	32,471.87
KARI M BRATHEN 1927 LAKESHORE DR	REFUNDS CHECK NO. - 00604339	541.46
MARGUERITE CLARITY 321 S SHELLEY LAKE LN	REFUNDS CHECK NO. - 00604429	135.78
NEPTUNE TECHNOLOGY GROUP INC	EQUIPMENT REPAIRS/MAINTENANCE ACH PMT NO. - 80131509	153.29
NORFOLK IRON & METAL CO DBA CDA METALS	REPAIR & MAINTENANCE SUPPLIES CHECK NO. - 00604332	637.84
NORTHWEST INDUSTRIAL SERVICES DBA AMERICAN ON SITE SERVICES	OPERATING RENTALS/LEASES CREDIT CARD PMT NO. - 70000404	110.00
NUKEY REALTY 6419 N MONROE ST	REFUNDS CHECK NO. - 00604430	115.29
RHODES CRANE & RIGGING INC	CONSTRUCTION OF FIXED ASSETS ACH PMT NO. - 80131562	1,154.75
SAJB-WELLHEAD IMPLEMENTATION BOARD PROGRAM	CONTRACTUAL SERVICES ACH PMT NO. - 80131613	25,000.00
SPOKANE CITY TREASURER OR	WA DEPT OF REVENUE	

WASH STATE DEPT OF REVENUE	CHECK NO. - 00604439	193,021.04
SPOKANE CONCRETE CUTTING INC	CONSTRUCTION OF FIXED ASSETS CHECK NO. - 00604353	381.50
SPOKANE INT'L AIRPORT	OTH DUES/SUBSCRIPTNS/MEMBERSHP ACH PMT NO. - 80131514	80.00
THOMPSON TILE PO BOX 4448	REFUNDS CHECK NO. - 00604431	1,383.23
US BANK TRAVEL CARD	REPAIR & MAINTENANCE SUPPLIES ACH PMT NO. - 80131652	845.51-
WA STATE DEPT OF REVENUE	CONSTRUCTION OF FIXED ASSETS -	443.32

HONORABLE MAYOR
AND COUNCIL MEMBERS

07/22/24
PAGE 14

PROCESSING OF VOUCHERS RESULTS IN CLAIMS AS FOLLOWS:

WESTERN STATES EQUIPMENT CO	CONSTRUCTION OF FIXED ASSETS CREDIT CARD PMT NO. - 70000418	107,149.18
TOTAL FOR 4100 - WATER DIVISION		576,989.01

4250 - INTEGRATED CAPITAL MANAGEMENT

BERYL FREDRICKSON	OTHER TRANSPORTATION EXPENSES CHECK NO. - 00604334	376.54
BERYL FREDRICKSON	PER DIEM CHECK NO. - 00604334	100.50
BUDINGER & ASSOCIATES INC	CONSTRUCTION OF FIXED ASSETS ACH PMT NO. - 80131587	3,939.64
CONSOLIDATED SUPPLY CO	CONSTRUCTION OF FIXED ASSETS ACH PMT NO. - 80131497	78,531.61
DW EXCAVATING INC	CONSTRUCTION OF FIXED ASSETS ACH PMT NO. - 80131600	384,516.50
LARIVIERE INC	CONSTRUCTION OF FIXED ASSETS ACH PMT NO. - 80131607	30,735.15
LSB CONSULTING ENGINEERS PLLC	CONSTRUCTION OF FIXED ASSETS ACH PMT NO. - 80131508	56,975.87
MDM CONSTRUCTION GROUP INC	CONSTRUCTION OF FIXED ASSETS ACH PMT NO. - 80131640	126,800.34
SPOKANE CITY TREASURER OR WASH STATE DEPT OF REVENUE	WA DEPT OF REVENUE CHECK NO. - 00604439	60,557.30
T BAILEY INC	CONSTRUCTION OF FIXED ASSETS ACH PMT NO. - 80131619	281,435.67
TOTAL FOR 4250 - INTEGRATED CAPITAL MANAGEMENT		1,023,969.12

4300 - SEWER FUND

DREW AND SARA FERGUSON PO BOX 1770	REFUNDS CHECK NO. - 00604427	40.00
---------------------------------------	---------------------------------	-------

TOTAL FOR 4300 - SEWER FUND

40.00

4310 - SEWER MAINTENANCE DIVISION

COLEMAN OIL COMPANY LLC	MOTOR FUEL-OUTSIDE VENDOR ACH PMT NO. - 80131495	2,936.68
KAISER FOUNDATION HEALTH OF WASHINGTON	MEDICAL SERVICES CHECK NO. - 00604318	275.00

HONORABLE MAYOR
AND COUNCIL MEMBERS07/22/24
PAGE 15

PROCESSING OF VOUCHERS RESULTS IN CLAIMS AS FOLLOWS:

PARAMETRIX INC	CONSTRUCTION OF FIXED ASSETS ACH PMT NO. - 80131610	1,310.00
PRORATE AND FUEL TAX DEPT OF LICENSING	WA DEPT OF REVENUE CHECK NO. - 00604357	1,534.92
SPOKANE CITY TREASURER OR WASH STATE DEPT OF REVENUE	WA DEPT OF REVENUE CHECK NO. - 00604439	65,100.94

TOTAL FOR 4310 - SEWER MAINTENANCE DIVISION

71,157.54

4320 - RIVERSIDE PARK RECLAMATION FAC

ALS LABORATORY GROUP	TESTING SERVICES ACH PMT NO. - 80131486	290.00
AVISTA UTILITIES	UTILITY LIGHT/POWER SERVICE ACH PMT NO. - 80131490	167,630.42
CENTURYLINK	TELEPHONE CHECK NO. - 00604315	87.54
CINTAS CORPORATION	LAUNDRY/JANITORIAL SERVICES CREDIT CARD PMT NO. - 70000411	5,802.46
COLEMAN OIL COMPANY LLC	MOTOR FUEL-OUTSIDE VENDOR ACH PMT NO. - 80131527	3,090.41
COLUMBIA ELECTRIC SUPPLY/DIV CONSOLIDATED ELECTRICAL	REPAIR & MAINTENANCE SUPPLIES ACH PMT NO. - 80131528	7,459.44
CUESTA SPRINGS ICE COMPANY OF IDAHO LLC	OPERATING SUPPLIES ACH PMT NO. - 80131533	65.40
ENDRESS+HAUSER INC C/O FIELD INSTRUMENTS & CONTRO	OPERATING SUPPLIES CREDIT CARD PMT NO. - 70000407	2,039.23
ENDRESS+HAUSER INC C/O FIELD INSTRUMENTS & CONTRO	REPAIR & MAINTENANCE SUPPLIES CREDIT CARD PMT NO. - 70000407	234.34
ENTERPRISE FM TRUST ATTN: CUSTOMER BILLING	OPERATING RENTALS/LEASES ACH PMT NO. - 80131501	577.45
HASA INC	CHEMICAL/LAB SUPPLIES ACH PMT NO. - 80131505	15,509.87
INLAND ENVIRONMENTAL RESOURCES INC	CHEMICAL/LAB SUPPLIES ACH PMT NO. - 80131506	7,838.74

MIDLAND SCIENTIFIC INC	REPAIR & MAINTENANCE SUPPLIES CREDIT CARD PMT NO. - 70000408	3,530.55
POINTE PEST CONTROL	CONTRACTUAL SERVICES CHECK NO. - 00604434	1,466.05
POLYDYNE INC	CHEMICAL/LAB SUPPLIES CREDIT CARD PMT NO. - 70000409	22,930.88

HONORABLE MAYOR
AND COUNCIL MEMBERS

07/22/24
PAGE 16

PROCESSING OF VOUCHERS RESULTS IN CLAIMS AS FOLLOWS:

PRORATE AND FUEL TAX DEPT OF LICENSING	MOTOR FUEL-OUTSIDE VENDOR CHECK NO. - 00604449	1,054.00
SPOKANE CITY TREASURER OR WASH STATE DEPT OF REVENUE	WA DEPT OF REVENUE CHECK NO. - 00604439	68,391.10
STELLAR INDUSTRIAL SUPPLY INC	SAFETY SUPPLIES ACH PMT NO. - 80131572	523.71
US BANK TRAVEL CARD	AIRFARE ACH PMT NO. - 80131652	269.41
VERIZON WIRELESS	CELL PHONE ACH PMT NO. - 80131515	1,241.27
TOTAL FOR 4320 - RIVERSIDE PARK RECLAMATION FAC		310,032.27

4330 - STORMWATER

AVISTA UTILITIES	UTILITY LIGHT/POWER SERVICE ACH PMT NO. - 80131490	2,129.44
KAISER FOUNDATION HEALTH OF WASHINGTON	MEDICAL SERVICES CHECK NO. - 00604336	138.00
TOTAL FOR 4330 - STORMWATER		2,267.44

4480 - SOLID WASTE FUND

SPOKANE CITY TREASURER OR WASH STATE DEPT OF REVENUE	DEPOSIT-REFUSE COLLECTION TAX CHECK NO. - 00604439	23.16
SPOKANE CITY TREASURER OR WASH STATE DEPT OF REVENUE	DEPOSIT-SALES TAX CHECK NO. - 00604439	2,407.80
TOTAL FOR 4480 - SOLID WASTE FUND		2,430.96

4490 - SOLID WASTE DISPOSAL

BANNER FURNACE & FUEL	OPERATING SUPPLIES ACH PMT NO. - 80131491	168.95
BEARING DISTRIBUTORS INC dba BROWN BEARING	REPAIR & MAINTENANCE SUPPLIES ACH PMT NO. - 80131492	625.88
CENTURYLINK	TELEPHONE CHECK NO. - 00604331	76.83
ECOICHEM ANALYTICS INC	REPAIR & MAINTENANCE SUPPLIES	

	ACH PMT NO. - 80131537	3,233.08
ELJAY OIL CO INC	LUBRICANTS	
	CREDIT CARD PMT NO. - 70000406	263.18

HONORABLE MAYOR
AND COUNCIL MEMBERS

07/22/24
PAGE 17

PROCESSING OF VOUCHERS RESULTS IN CLAIMS AS FOLLOWS:

ELJAY OIL CO INC	MOTOR FUEL-OUTSIDE VENDOR CREDIT CARD PMT NO. - 70000412	1,880.75
FASTENAL CO	OPERATING SUPPLIES ACH PMT NO. - 80131540	96.68
FASTENAL CO	PERSONAL PROTECTIVE EQUIPMENT ACH PMT NO. - 80131540	857.72
FASTENAL CO	REPAIR & MAINTENANCE SUPPLIES ACH PMT NO. - 80131540	778.88
NORTHSTAR CHEMICAL INC	CHEMICAL/LAB SUPPLIES ACH PMT NO. - 80131510	3,539.97
NORTHWEST INDUSTRIAL SERVICES DBA AMERICAN ON SITE SERVICES	OPERATING RENTALS/LEASES CREDIT CARD PMT NO. - 70000404	1,344.59
PETE LIEN & SONS INC	CHEMICAL/LAB SUPPLIES ACH PMT NO. - 80131559	44,833.74
SPOKANE CITY TREASURER OR WASH STATE DEPT OF REVENUE	WA DEPT OF REVENUE CHECK NO. - 00604439	29,628.22
UNITED RENTALS NW INC	OPERATING RENTALS/LEASES CHECK NO. - 00604356	2,310.38
VERIZON WIRELESS	CELL PHONE ACH PMT NO. - 80131574	678.36
WATERCO OF THE PACIFIC NORTH WEST, INC	OPERATING SUPPLIES CHECK NO. - 00604333	246.49

	TOTAL FOR 4490 - SOLID WASTE DISPOSAL	90,563.70

4500 - SOLID WASTE COLLECTION

ACRANET CBS BRANCH/DIV OF CBS REPORTING INC	BACKGROUND CHECKS ACH PMT NO. - 80131584	40.00
AVISTA UTILITIES	UTILITY LIGHT/POWER SERVICE ACH PMT NO. - 80131490	1,260.77
AVISTA UTILITIES	UTILITY NATURAL GAS ACH PMT NO. - 80131490	352.56
HOTSY OF SPOKANE LLC	OPERATING SUPPLIES ACH PMT NO. - 80131605	16,605.25
KAISER FOUNDATION HEALTH OF WASHINGTON	MEDICAL SERVICES CHECK NO. - 00604319	98.00
SPOKANE CITY TREASURER OR WASH STATE DEPT OF REVENUE	WA DEPT OF REVENUE CHECK NO. - 00604439	106,861.48
SPOKANE INT'L AIRPORT	PERMITS/OTHER FEES ACH PMT NO. - 80131514	100.00

PROCESSING OF VOUCHERS RESULTS IN CLAIMS AS FOLLOWS:

TOTAL FOR 4500 - SOLID WASTE COLLECTION		----- 125,318.06
4530 - SOLID WASTE LANDFILLS		

ACCESS UNLIMITED & SECURITY INC	ALARM/SECURITY SERVICES CHECK NO. - 00604330	183.12
NORTHWEST INDUSTRIAL SERVICES DBA AMERICAN ON SITE SERVICES	OPERATING RENTALS/LEASES CREDIT CARD PMT NO. - 70000404	220.00
VERIZON WIRELESS	CELL PHONE ACH PMT NO. - 80131574	82.75
TOTAL FOR 4530 - SOLID WASTE LANDFILLS		----- 485.87
4600 - GOLF FUND		

ACRANET CBS BRANCH/DIV OF CBS REPORTING INC	BACKGROUND CHECKS ACH PMT NO. - 80131584	24.00
TOTAL FOR 4600 - GOLF FUND		----- 24.00
4700 - DEVELOPMENT SVCS CENTER		

ENTERPRISE FM TRUST ATTN: CUSTOMER BILLING	OPERATING RENTALS/LEASES ACH PMT NO. - 80131501	1,905.93
GAFFANEY ELECTRIC 40606 N BRUCE RD	PERMIT REFUNDS PAYABLE CHECK NO. - 00604425	40.00
SHUMS CODA ASSOCIATES INC	CONTRACTUAL SERVICES CHECK NO. - 00604352	9,000.00
TODD MENIER	OTH DUES/SUBSCRIPTNS/MEMBERSHP ACH PMT NO. - 80131624	165.00
TODD MENIER	REGISTRATION/SCHOOLING ACH PMT NO. - 80131624	610.00
TOTAL FOR 4700 - DEVELOPMENT SVCS CENTER		----- 11,720.93
5100 - FLEET SERVICES FUND		

ASPEN AERIALS INC	VEHICLE REPAIR & MAINT SUPPLY ACH PMT NO. - 80131489	29.67
AVISTA UTILITIES	UTILITY LIGHT/POWER SERVICE ACH PMT NO. - 80131490	420.26
AVISTA UTILITIES	UTILITY NATURAL GAS ACH PMT NO. - 80131490	33.08

PROCESSING OF VOUCHERS RESULTS IN CLAIMS AS FOLLOWS:

COLEMAN OIL COMPANY LLC	MOTOR FUEL-OUTSIDE VENDOR ACH PMT NO. - 80131590	42,911.25
CONNELL OIL INC DBA CO-ENERGY	LUBRICANTS ACH PMT NO. - 80131592	605.07
COPIERS NORTHWEST INC	OPERATING RENTALS/LEASES ACH PMT NO. - 80131595	718.04
EVERGREEN STATE TOWING LLC DBA SPOKANE VALLEY TOWING	TOWING EXPENSE CREDIT CARD PMT NO. - 70000425	2,006.69
FLEET PAINTING INC	EQUIPMENT REPAIRS/MAINTENANCE CREDIT CARD PMT NO. - 70000420	4,675.01
GORDON TRUCK CENTERS INC DBA PACIFIC TRUCK CENTERS	EQUIPMENT REPAIRS/MAINTENANCE CREDIT CARD PMT NO. - 70000422	3,793.68
JHAB3 CO DBA MEINEKE CAR CARE CENTER	EQUIPMENT REPAIRS/MAINTENANCE CHECK NO. - 00604432	5,265.43
JOSE A CARRANZA	PERMITS/OTHER FEES CHECK NO. - 00604422	108.15
KENWORTH SALES COMPANY	EQUIPMENT REPAIRS/MAINTENANCE ACH PMT NO. - 80131606	1,749.15
MEGA WASH LLC	CONTRACTUAL SERVICES ACH PMT NO. - 80131608	5,162.16
NOVUS AUTO GLASS	EQUIPMENT REPAIRS/MAINTENANCE ACH PMT NO. - 80131643	811.75
SOLID WASTE SYSTEMS INC dba SWS EQUIPMENT INC	EQUIPMENT REPAIRS/MAINTENANCE ACH PMT NO. - 80131646	83,979.09
TOBY'S BODY & FENDER INC	EQUIPMENT REPAIRS/MAINTENANCE ACH PMT NO. - 80131649	7,403.90

TOTAL FOR 5100 - FLEET SERVICES FUND -----
159,672.38

5110 - FLEET SVCS EQUIP REPL FUND

ENTERPRISE FM TRUST ATTN: CUSTOMER BILLING	OPERATING RENTALS/LEASES ACH PMT NO. - 80131501	2,967.63
---	--	----------

TOTAL FOR 5110 - FLEET SVCS EQUIP REPL FUND -----
2,967.63

5200 - PUBLIC WORKS AND UTILITIES

IBEX FLOORING LLC	CONTRACTUAL SERVICES ACH PMT NO. - 80131634	22,263.25
SPOKANE CITY TREASURER OR WASH STATE DEPT OF REVENUE	WA DEPT OF REVENUE CHECK NO. - 00604439	1,444.69

HONORABLE MAYOR
AND COUNCIL MEMBERS

07/22/24
PAGE 20

PROCESSING OF VOUCHERS RESULTS IN CLAIMS AS FOLLOWS:

TOTAL FOR 5200 - PUBLIC WORKS AND UTILITIES 23,707.94

5300 - IT FUND

CENTURYLINK TELEPHONE
CHECK NO. - 00604331 5,605.16

COMCAST IT/DATA SERVICES
CHECK NO. - 00604316 225.90

LEVEL 3 FINANCING INC TELEPHONE
DBA LEVEL 3 COMMUNICATIONS LLC CHECK NO. - 00604320 3,654.31

PITNEY BOWES HARDWARE MAINTENANCE
CHECK NO. - 00604312 8,888.65

PITNEY BOWES OPERATING RENTALS/LEASES
CHECK NO. - 00604312 24,197.46

SHI CORP SOFTWARE MAINTENANCE
ACH PMT NO. - 80131566 1,088.48

T-MOBILE IT/DATA SERVICES
CHECK NO. - 00604355 29.75

VERIZON WIRELESS CELL PHONE
ACH PMT NO. - 80131574 1,591.37

TOTAL FOR 5300 - IT FUND 45,281.08

5310 - IT CAPITAL REPLACEMENT FUND

DELL MARKETING LP COMPUTERS
%DELL USA LP ACH PMT NO. - 80131599 3,026.50

DELL MARKETING LP MINOR EQUIPMENT
%DELL USA LP ACH PMT NO. - 80131599 5,531.53

TOTAL FOR 5310 - IT CAPITAL REPLACEMENT FUND 8,558.03

5400 - REPROGRAPHICS FUND

ED HAIGHT SERVICE EQUIPMENT REPAIRS/MAINTENANCE
ACH PMT NO. - 80131578 208.41

TOTAL FOR 5400 - REPROGRAPHICS FUND 208.41

5600 - ACCOUNTING SERVICES

US BANK TRAVEL CARD LODGING
ACH PMT NO. - 80131652 725.65

HONORABLE MAYOR 07/22/24
AND COUNCIL MEMBERS PAGE 21

PROCESSING OF VOUCHERS RESULTS IN CLAIMS AS FOLLOWS:

US BANK TRAVEL CARD OTHER TRANSPORTATION EXPENSES
ACH PMT NO. - 80131652 136.66

TOTAL FOR 5600 - ACCOUNTING SERVICES 862.31

5700 - MY SPOKANE

VERIZON WIRELESS	CELL PHONE ACH PMT NO. - 80131574	184.32
TOTAL FOR 5700 - MY SPOKANE		184.32

5800 - RISK MANAGEMENT FUND

US BANK OR CITY TREASURER LIABILITY CLAIMS	INSURANCE CLAIMS ACH PMT NO. - 80131621	38,730.28
VERIZON WIRELESS	CELL PHONE ACH PMT NO. - 80131574	170.96
TOTAL FOR 5800 - RISK MANAGEMENT FUND		38,901.24

5810 - WORKERS' COMPENSATION FUND

COPIERS NORTHWEST INC	OPERATING RENTALS/LEASES ACH PMT NO. - 80131595	237.60
TOTAL FOR 5810 - WORKERS' COMPENSATION FUND		237.60

5830 - EMPLOYEES BENEFITS FUND

DELTA DENTAL OF WASHINGTON	INSURANCE CLAIMS ACH PMT NO. - 80131630	36,530.13
KAISER FOUNDATION HEALTH PLAN OF WASHINGTON	INSURANCE CLAIMS ACH PMT NO. - 80131637	151,358.52
PREMERA BLUE CROSS OR SPOKANE CITY TREASURER	INSURANCE CLAIMS ACH PMT NO. - 80131561	763,759.87
TOTAL FOR 5830 - EMPLOYEES BENEFITS FUND		951,648.52

5900 - FACILITIES MANAGEMENT FUND OPS

ABM JANITORIAL SERVICES SOUTH SOUTH CENTRAL INC dba	CONTRACTUAL SERVICES ACH PMT NO. - 80131583	2,169.36
AVISTA CORPORATION	UTILITY LIGHT/POWER SERVICE ACH PMT NO. - 80131521	8,868.16

HONORABLE MAYOR
AND COUNCIL MEMBERS

07/22/24
PAGE 22

PROCESSING OF VOUCHERS RESULTS IN CLAIMS AS FOLLOWS:

AVISTA CORPORATION	UTILITY NATURAL GAS ACH PMT NO. - 80131521	1,044.24
CAMTEK INC	BUILDING REPAIRS/MAINTENANCE ACH PMT NO. - 80131493	163.50
CAMTEK INC	REPAIR & MAINTENANCE SUPPLIES ACH PMT NO. - 80131525	10,216.17

GOODALE & BARBIERI COMPANY	OTHER CONTRACTUAL SERVICES ACH PMT NO. - 80131544	2,500.00
NIKKI HANSHAW	LOCAL MILEAGE ACH PMT NO. - 80131579	49.65
OVERHEAD DOOR CORPORATION DBA WAYNE DALTON SALES &	BUILDING REPAIRS/MAINTENANCE CHECK NO. - 00604359	6,549.81
ROBERT MOORE	LOCAL MILEAGE ACH PMT NO. - 80131581	11.06
RUSTY J BOICOURT DBA VERITAS MATERIAL CONSULTING LLC	BUILDING REPAIRS/MAINTENANCE ACH PMT NO. - 80131653	9,930.00
TOTAL FOR 5900 - FACILITIES MANAGEMENT FUND OPS		41,501.95

5903 - PROPERTY ACQUISITION FIRE

L N CURTIS & SONS	PERSONAL PROTECTIVE EQUIPMENT ACH PMT NO. - 80131598	6,171.20
TOTAL FOR 5903 - PROPERTY ACQUISITION FIRE		6,171.20

5904 - FACILITIES CAPITAL

CONTROL SOLUTIONS NW INC	OTHER IMPROVEMENTS ACH PMT NO. - 80131594	87,892.20
KRUEGER SHEET METAL COMPANY	BUILDING REPAIRS/MAINTENANCE ACH PMT NO. - 80131638	26,754.05
TOTAL FOR 5904 - FACILITIES CAPITAL		114,646.25

6200 - FIREFIGHTERS' PENSION FUND

DELTA DENTAL OF WASHINGTON	SERVICE REIMBURSEMENT ACH PMT NO. - 80131630	4,672.69
PREMERA BLUE CROSS OR SPOKANE CITY TREASURER	SERVICE REIMBURSEMENT ACH PMT NO. - 80131561	60,509.48
SPOKANE LIFELINE INC	SERVICE REIMBURSEMENT CHECK NO. - 00604440	21.80

HONORABLE MAYOR
AND COUNCIL MEMBERS

07/22/24
PAGE 23

PROCESSING OF VOUCHERS RESULTS IN CLAIMS AS FOLLOWS:

SPOKANE UNITED METHODIST HOME dba ROCKWOOD SOUTH HILL	SERVICE REIMBURSEMENT CHECK NO. - 00604438	9,295.00
SPOKANE UNITED METHODIST HOME dba ROCKWOOD SOUTH HILL	SERVICE REIMBURSEMENT CHECK NO. - 00604438	68.71
TOTAL FOR 6200 - FIREFIGHTERS' PENSION FUND		74,567.68

6300 - POLICE PENSION

DELTA DENTAL OF WASHINGTON	SERVICE REIMBURSEMENT
----------------------------	-----------------------

	ACH PMT NO. - 80131630	1,752.00
PREMERA BLUE CROSS OR SPOKANE CITY TREASURER	SERVICE REIMBURSEMENT ACH PMT NO. - 80131561	53,655.41
SULLIVAN VENTURES, LLC DBA SULLIVAN PARK ASSISTED LVG	SERVICE REIMBURSEMENT CHECK NO. - 00604441	5,685.00
SULLIVAN VENTURES, LLC DBA SULLIVAN PARK ASSISTED LVG	SERVICE REIMBURSEMENT CHECK NO. - 00604441	1,775.00

TOTAL FOR 6300 - POLICE PENSION		62,867.41
6730 - PARKING & BUSINESS IMPROV DIST		

DOWNTOWN SPOKANE PARTNERSHIP 818 W RIVERSIDE AVE STE 120	DEPOSIT-MISCELLANEOUS DEPOSITS CHECK NO. - 00604340	14,721.73
EAST SPRAGUE BUSINESS ASSOCIATION	DEPOSIT-MISCELLANEOUS DEPOSITS CHECK NO. - 00604341	306.81
LETICIA BLAND 315 W RIVERSIDE AVE #501	SPECIAL ASSESSMENT PRIN (CURR) CHECK NO. - 00604342	104.47

TOTAL FOR 6730 - PARKING & BUSINESS IMPROV DIST		15,133.01

TOTAL CLAIMS		5,262,749.16



Agenda Sheet for City Council:

Committee: Date: N/A

Committee Agenda type:

Council Meeting Date: 08/12/2024

Date Rec'd 7/31/2024

Clerk's File # CPR 2024-0002

Cross Ref #

Project #

Submitting Dept ACCOUNTING & GRANTS **Bid #**

Contact Name/Phone LEONARD 625-6028 **Requisition #**

Contact E-Mail LDAVIS@SPOKANECITY.ORG

Agenda Item Type Claim Item

Council Sponsor(s)

Agenda Item Name 5600-CLAIMS-2024

Agenda Wording

Report of the Mayor of pending claims & payments of previously approved obligations through: 07/26/2024. Total:\$14,926,503.07 with Parks & Library claims being approved by their respective boards. Claims excluding Parks & Library Total:\$14,575,604.61

Summary (Background)

Pages 1-35 Check numbers: 604450 - 604614 Credit Card numbers: 000428 - 000449 ACH payment numbers: 131661 - 131866 On file for review in City Clerks Office: 35 Page listing of Claims Note:

Lease? NO Grant related? NO Public Works? NO

Fiscal Impact

Approved in Current Year Budget?

Total Cost \$

Current Year Cost \$

Subsequent Year(s) Cost \$

Narrative

Amount

Budget Account

Expense \$ \$14,575,604.61 # Various

Select \$ #

Select \$ #

Select \$ #

\$ #

\$ #

REPORT: PG3620
SYSTEM: FMSAP
USER: MANAGER
RUN NO: 30

APPROVAL FUND SUMMARY

DATE: 07/29/24
TIME: 10:06
PAGE: 1

FUND	FUND NAME	AMOUNT
0100	GENERAL FUND	806,537.36
1100	STREET FUND	171,834.26
1200	CODE ENFORCEMENT FUND	13,725.64
1300	LIBRARY FUND	53,155.88
1360	MISCELLANEOUS GRANTS FUND	572.04
1380	TRAFFIC CALMING MEASURES	362,852.72
1390	URBAN FORESTRY FUND	555.96
1400	PARKS AND RECREATION FUND	82,772.75
1425	AMERICAN RESCUE PLAN	64,586.14
1460	PARKING METER REVENUE FUND	9,636.80
1560	FORFEITURES & CONTRIBUTION FND	378.00
1620	PUBLIC SAFETY & JUDICIAL GRANT	3,773.72
1625	PUBLIC SAFETY PERSONNEL FUND	34,753.06
1640	COMMUNICATIONS BLDG M&O FUND	91.82
1680	CD/HS OPERATIONS	13,408.35
1910	CRIMINAL JUSTICE ASSISTANCE FD	3,741.64
1970	FIRE/EMS FUND	343,646.18
1990	TRANSPORTATION BENEFIT FUND	846,784.92
3200	ARTERIAL STREET FUND	903,687.96
4100	WATER DIVISION	519,633.66
4250	INTEGRATED CAPITAL MANAGEMENT	114,641.03
4300	SEWER FUND	610,280.80
4480	SOLID WASTE FUND	1,486,828.87
4600	GOLF FUND	13,549.09
4700	DEVELOPMENT SVCS CENTER	40,704.57
5100	FLEET SERVICES FUND	106,173.07
5200	PUBLIC WORKS AND UTILITIES	87,699.08
5300	IT FUND	117,800.46
5310	IT CAPITAL REPLACEMENT FUND	171,197.15
5400	REPROGRAPHICS FUND	1,217.55
5500	PURCHASING & STORES FUND	5,938.39
5600	ACCOUNTING SERVICES	27,378.40
5700	MY SPOKANE	16,417.95
5750	OFFICE OF PERFORMANCE MGMT	5,647.98
5800	RISK MANAGEMENT FUND	15,781.96
5810	WORKERS' COMPENSATION FUND	2,044.04
5820	UNEMPLOYMENT COMPENSATION FUND	766,909.54
5830	EMPLOYEES BENEFITS FUND	1,604,827.16
5900	FACILITIES MANAGEMENT FUND OPS	68,359.32
5902	PROPERTY ACQUISITION POLICE	346,954.79
6060	EMPLOYEES' RETIREMENT FUND	2,102.92
6070	FIREFIGHTERS' PENSION FUND	29,661.12
6080	POLICE PENSION FUND	13,685.99
6255	LAW ENFORCEMENT RECORDS MGMT	24,089.50
6960	SALARY CLEARING FUND NEW	3,427,113.69
TOTAL:		13,343,133.28

REPORT: PG3630
SYSTEM: FMSAP
USER: MANAGER
RUN NO: 30

DATE: 07/29/24
TIME:
PAGE: 1

HONORABLE MAYOR
AND COUNCIL MEMBERS

07/29/24
PAGE 2

PROCESSING OF VOUCHERS RESULTS IN CLAIMS AS FOLLOWS:

REPORT: PG3640
SYSTEM: FMSAP
USER: MANAGER
RUN NO: 30

CITY OF SPOKANE
COUNCIL CHECK RANGE/TOTAL

DATE: 07/29/24
TIME: 10:06
PAGE: 1

CHECK #	VENDOR	CITY	LIBRARY	PARKS
	USE TAX AMOUNTS		22.01	
00604450	BIG SKY INDUSTRIAL/DIV OF	46,778.90		
00604451	CASCADE ENGINEERING INC	87,343.88		
00604452	CENTURYLINK	10,853.99		
00604453	EVANS ENGINEERING AND	1,158.75		
00604454	KAISER FOUNDATION HEALTH OF	7,383.00		
00604455	MOON SECURITY SERVICES INC	20.00		
00604456	RIGHT NOW HEATING AND COOLIN	45.00		
00604457	RIGHT NOW HEATING AND COOLIN	20.00		
00604458	ORKIN	201.64		
00604459	MORGAN SEVERNS	136.00		
00604460	UNITED RENTALS NW INC	3,675.48		
00604461	UNITED STATES GEOLOGICAL	5,306.00		
00604462	US POSTMASTER	50,000.00		
00604463	WA STATE DEPT OF REVENUE	134.02		
00604464	WASTEQUIP WASHINGTON	700.88		
00604467	AT&T MOBILITY	12.43		
00604468	CENTURYLINK	543.03		
00604469	YP AUTOMOTIVE INC	162.42		
00604470	KELSEY DELONG	338.70		
00604474	CHICK-FIL-A	210.00		
00604475	CANYON BUFFS APTS	44.00		
00604476	GRAPETREE MIXED USE	38.00		
00604477	HOLIDAY INN SPOKANE	38.00		
00604478	ICCU	76.00		
00604479	OXFORD HOUSE COOK STREET	233.34		
00604480	ORKIN	1,329.75		
00604481	SPOKANE COUNTY TITLE CO	253,772.54		
00604482	T-MOBILE USA INC	100.00		
00604483	WA STATE DEPT OF LICENSING	165.00		
00604484	WA STATE DEPT OF LICENSING	1,641.00		
00604485	WA STATE DEPT OF LICENSING	17,160.00		
00604486	WA STATE EMPLOYMENT SECURITY	498,518.99		
00604487	WA STATE EMPLOYMENT SECURITY	268,373.71		
00604488	WA STATE PATROL	5,123.50		
00604489	WAXIE SANITARY SUPPLY	1,164.04		
00604490	SWIRE PACIFIC HOLDINGS, INC			4,173.02
00604491	WAXIE SANITARY SUPPLY			2,532.72
00604492	AT&T MOBILITY	5,448.42		
00604493	CENTURYLINK	195.77		
00604494	COMCAST	162.69		
00604495	COMCAST	174.24		
00604496	ACTION DRAIN & ROOTER WA LLC	150.00		
00604497	MAINSTREAM ELECTRIC LLC	140.00		
00604498	ROBERT AND ROSALIE WOOD	25.00		
00604499	LINDA CAROTHERS OR	10.00		
00604500	JACOB WOLFF	18.00		
00604501	PUBLIC SAFETY TESTING INC	583.00		
00604502	TK ELEVATOR CORPORATION	1,205.54		
00604503	US BANK	23,896.13		
00604504	SAFETY KLEEN CORPORATION			525.37
00604505	US TREASURY	407.06		
00604561	BROADWAY TRUCK STOP/DIV OF	248.30		

REPORT: PG3640
SYSTEM: FMSAP
USER: MANAGER
RUN NO: 30

CITY OF SPOKANE
COUNCIL CHECK RANGE/TOTAL

DATE: 07/29/24
TIME: 10:06
PAGE: 2

CHECK #	VENDOR	CITY	LIBRARY	PARKS
00604562	CAD OF SPOKANE, INC.	2,604.24		
00604563	CASCADE ENGINEERING INC	38,350.56		
00604564	CENTURYLINK	407.64		
00604565	SKYLER COVER	392.00		
00604566	JACOB GREENWOOD	338.00		
00604567	BRETT E BURRIS	228.52		
00604568	ESTATE OF MARCIA LOOSMORE	50.00		
00604569	HORNBERGER PROPERTY MANAGEME	1,644.71		
00604570	PAM CAMERON	49.41		
00604571	PATRICK AND MICHELE MOORE	128.95		
00604572	RYAN ASKER	20.15		
00604573	RYAN CRISMAN	116.52		
00604574	THE IMPERIAL APTS LLC	134.94		
00604575	WATSON MANAGEMENT	316.40		
00604576	STURM HEATING INC	30.00		
00604577	SPOKANE NEIGHBORHOOD ACTION	20.00		
00604578	ALEX LYNCH	301.00		
00604579	SAFETY KLEEN CORPORATION	179.50		
00604580	SOLID WASTE MANAGEMENT IMPRE	9.00		
00604581	SPECIALTY ANALYTICAL	280.00		
00604582	METROPOLITAN TRANSPORTATION	9,000.00		
00604583	SWANA	1,580.00		
00604584	WA STATE DEPT OF LICENSING	378.00		
00604585	WAXIE SANITARY SUPPLY	3,148.66		
00604586	OVERHEAD DOOR CORPORATION	277.95		
00604587	WHITE BLOCK COMPANY INC	961.51		
00604588	BLOOMBERG FINANCE LP		7,020.00	
00604589	CENTER POINT PUBLISHING INC		244.50	
00604590	PATRON POINT INC		12,560.00	
00604591	CHILD SUPPORT SERVICES	1,352.88		
00604592	HUMAN RESOURCES	930.50		
00604593	ICMA RETIREMENT TRUST 457	521,952.67		
00604594	ICMA RETIREMENT TRUST 457 LO	57,044.61		
00604595	ING LIFE INSURANCE & ANNUITY	158,071.59		
00604596	KAISER FOUNDATION HEALTH OF	260.00		
00604597	PEOPLE QUALIFIED COMMITTEE	5.00		
00604598	MARTIN PITTMAN	165.00		
00604599	PRE-PAID LEGAL SERVICES INC	333.23		
00604600	SNOW PEAK 1 LIBERTY LAKE REA	7,325.00		
00604601	STATE DISBURSMENT UNIT	862.58		
00604602	UNITED STATES TREASURY	12.50		
00604603	US BANK OR CITY TREASURER	1,930,323.34		
00604604	VOYA FINANCIAL LOAN REPAYMEN	2,779.53		
00604605	WA GET PROGRAM	375.00		
00604606	WA STATE SUPPORT REGISTRY OR	15,965.52		
00604607	WASHINGTON LEOFF	1,139,156.98		
00604608	WELLTOWER PEGASUS TENNANT LL	7,637.00		
00604609	WESTERN STATES POLICE MEDICA	3,375.00		
00604610	ATLAS SAND AND ROCK INC			3,644.91
00604611	DE LAGE LANDEN FINANCIAL SVC			765.31
00604612	HERITAGE LANDSCAPE SUPPLY			443.28
00604613	MIRACLE PLAYSYSTEMS II, LLC			9,251.15
00604614	NW PLAYGROUND EQUIPMENT INC			4,188.43

REPORT: PG3640
SYSTEM: FMSAP
USER: MANAGER
RUN NO: 30

CITY OF SPOKANE
COUNCIL CHECK RANGE/TOTAL

DATE: 07/29/24
TIME: 10:06
PAGE: 3

CHECK #	VENDOR	CITY	LIBRARY	PARKS
70000428	AIRGAS SPECIALTY PRODUCTS IN	45,297.99		

70000429	BIG BELLY SOLAR LLC	6,734.70	
70000430	ELJAY OIL CO INC	3,675.30	
70000431	NORCO INC	617.38	
70000432	OXARC INC	4,590.97	
70000433	POLYDYNE INC	9,172.36	
70000434	ELJAY OIL CO INC	856.48	
70000435	GALLS LLC	30,877.60	
70000436	GENERAL KINEMATICS CORPORATI	3,002.18	
70000437	HORIZON DISTRIBUTORS		828.02
70000438	NORCO INC	1,821.84	
70000439	PLANET TURF		2,178.00
70000440	WESTERN STATES EQUIPMENT CO		4,083.69
70000441	SECOND HARVEST FOOD BANK OF	2,680.73	
70000442	ALASKA RUBBER GROUP INC	189.32	
70000443	CINTAS CORPORATION	11,824.57	
70000444	ENDRESS+HAUSER INC	2,703.55	
70000445	EVERGREEN STATE TOWING LLC	1,399.56	
70000446	OVERDRIVE INC		13,412.21
70000447	SIGNS FOR SUCCESS INC	3,551.70	
70000448	GALLS LLC	840.63	
70000449	SITEONE LANDSCAPE SUPPLY LLC		1,868.94
80131661	ALS LABORATORY GROUP	2,380.00	
80131662	AVISTA UTILITIES	9,804.61	
80131663	BARR-TECH LLC	35,993.90	
80131664	C & C YARD CARE	3,486.50	
80131665	CAMTEK INC	725.57	
80131666	CLARK'S CONTAINERS LLC	232.72	
80131667	CLARY LONGVIEW LLC	346,954.79	
80131668	COMPUNET INC	172,287.51	
80131669	COPIERS NORTHWEST INC	2,850.20	
80131670	CORRECT EQUIPMENT INC	4,977.20	
80131671	COWLES PUBLISHING COMPANY	520.00	
80131672	DEECO INC	94,820.00	
80131673	ENNIS FLINT INC	22,710.16	
80131674	FASTENAL CO	3,283.66	
80131675	GORLEY LOGISTICS LLC	8.32	
80131676	FIRE CONTROL SPRINKLER SYSTE	2,538.00	
80131677	FISHER SCIENTIFIC	2,515.50	
80131678	GOBLE SAMPSON ASSOCIATES	4,501.70	
80131679	GRANICUS LLC	51,630.25	
80131680	HASA INC	15,620.92	
80131681	INLAND ENVIRONMENTAL RESOURC	7,524.90	
80131682	INLAND POWER & LIGHT CO	91.64	
80131683	KEMIRA WATER SOLUTIONS INC	82,547.21	
80131684	KNIGHT CONSTRUCTION &	440,442.98	
80131685	MCKINSTRY CO LLC	8,424.99	
80131686	NB ENGINEERING LLC	10,623.00	
80131687	OIL RE-REFINING CO INC	778.75	
80131688	ROGUE HEART MEDIA SPC	3,981.75	
80131689	BRANDSAFWAY SERVICES INC	9,933.23	
80131690	SMARTSIGHTS TECHNOLOGIES LLC	4,905.00	
80131691	SPECIALTY MACHINING & MFG CO	686.70	

REPORT: PG3640
SYSTEM: FMSAP
USER: MANAGER
RUN NO: 30

CITY OF SPOKANE
COUNCIL CHECK RANGE/TOTAL

DATE: 07/29/24
TIME: 10:06
PAGE: 4

CHECK #	VENDOR	CITY	LIBRARY	PARKS
80131692	SPOKANE COUNTY TREASURER	2,421.18		
80131693	SPOKANE INT'L AIRPORT	66,585.60		
80131694	SPOKANE PRO CARE INC	893.80		
80131695	TWO RIVERS TERMINAL LLC	11,750.90		
80131696	VERIZON WIRELESS	670.19		

80131697	WASHINGTON EQUIPMENT	50,659.23		
80131698	BENDER CCP INC	130,745.50		
80131699	AMBER GROE	41.81		
80131700	ABM JANITORIAL SERVICES SOUT	4,403.70		
80131701	ALTA LANGUAGE SERVICES INC	110.00		
80131702	AM HARDWARE CO	588.16		
80131703	AVISTA CORPORATION	22,136.25		
80131704	AVISTA UTILITIES	1,599.87		
80131705	CAMTEK INC	1,635.00	8,166.92	
80131706	CDW GOVERNMENT INC		794.27	
80131707	COLEMAN OIL COMPANY LLC	9,992.76	5,653.21	
80131708	COPIERS NORTHWEST INC	16.82		
80131709	DELL MARKETING LP	572.32		
80131710	ELECTRIC CITY INC		1,413.40	
80131711	EMPIRE SPRAY SERVICE		4,740.75	
80131712	EUROFINS ENVIRONMENT TESTING	182.50		
80131713	EVOQUA WATER TECHNOLOGIES LL	743.92		
80131714	FASTENAL CO	843.18		
80131715	ENCORE VENTURES LLC		245.27	
80131716	GORLEY LOGISTICS LLC	16.64		
80131717	GRAINGER INC	331.78		
80131718	MARUBENI AMERICA CORPORATION		11,356.54	
80131719	HUBER TECHNOLOGY INC	3,659.24		
80131720	KBG DEVELOPMENTS LLC	63.72		
80131721	LEXIS-NEXIS RISK & ANALYTICS	163.50		
80131722	NONICA ANDREW DBA MARSHALLES	3,213.00		
80131723	CAR WASH PARTNERS LLC	220.00		
80131724	NORTHSTAR CHEMICAL INC	3,748.20		
80131725	OTIS ELEVATOR COMPANY	456.70		
80131726	PETE LIEN & SONS INC	34,328.66		
80131727	ROAR WORKS LLC	19,314.80		
80131728	SPOKANE COUNTY TREASURER	1,120.12		
80131729	TWO RIVERS TERMINAL LLC	9,587.08		
80131730	VERIZON WIRELESS	721.14		
80131731	VERTICAL OPTIONS LLC	4,231.38		
80131732	VOLT MANAGEMENT CORP	9,506.86		
80131733	WA STATE DEPT/TRANSPORTATION	222.50		
80131734	WA STATE DEPT OF ECOLOGY	221,960.50		
80131735	WILBUR ELLIS COMPANY		5,756.51	
80131736	WILDROSE LTD dba		2,851.33	
80131737	KEVIN M SMITH	535.10		
80131739	AVISTA UTILITIES	8,186.27		
80131740	BROWN AND CALDWELL	1,384.61		
80131741	BUDINGER & ASSOCIATES INC	1,799.72		
80131742	COFFMAN ENGINEERS INC		24,958.70	
80131743	GHD INC	63,683.75		
80131744	GROUNDWATER SOLUTIONS INC	20,105.91		
80131745	GUNARAMA WHOLESALE INC	38.47		

REPORT: PG3640

CITY OF SPOKANE

DATE: 07/29/24

SYSTEM: FMSAP

COUNCIL CHECK RANGE/TOTAL

TIME: 10:06

USER: MANAGER

PAGE: 5

RUN NO: 30

CHECK #	VENDOR	CITY	LIBRARY	PARKS
80131746	INLAND INFRASTRUCTURE LLC	393,136.28		
80131747	WILLAR CORP dba	3,275.94		
80131748	KAISER FOUNDATION HEALTH PLA	112,632.59		
80131749	LEGEND INVESTMENTS CORP	816.75		
80131750	PMTECH INC	200.00		
80131751	PREMERA BLUE CROSS OR	305,065.50		
80131752	THE SALVATION ARMY	1,209,841.39		
80131753	SHAMROCK PAVING CO/DIV OF	1,369,737.44		
80131754	SITECRAFTING INC	495.00		

80131755	SPOKANE COUNTY TREASURER	13,895.35	
80131756	TRANSITIONS DBA TRANSITIONAL	13,415.96	
80131757	US BANK OR CITY TREASURER	12,962.68	
80131758	US BANK P CARD PAYMENTS	103,758.77	
80131759	VERIZON WIRELESS	3,739.94	
80131760	VOLUNTEERS OF AMERICA OF	2,391.24	
80131761	WA STATE CRIMINAL JUSTICE	300.00	
80131762	YFA CONNECTIONS	2,083.37	
80131763	YWCA	1,156.58	
80131764	ANTHONY LAMANNA	1,988.00	
80131765	RYAN MILLER	150.00	
80131766	ALLIANT INSURANCE SERVICES I	9,050.00	
80131767	ALLIED ENVELOPE	44,050.10	
80131768	ALSCO DIVISION OF ALSCO INC	4,858.98	
80131769	AM HARDWARE CO	281.00	
80131770	AMERICAN RADIATOR INC	156.34	
80131771	AVISTA UTILITIES	1,715.15	
80131772	BAKER & TAYLOR BOOKS		6,981.51
80131773	BATTERY SYSTEMS INC	3,436.56	
80131774	CENGAGE LEARNING INC		324.27
80131775	CINTAS CORPORATION NO 2	162.17	
80131776	COLEMAN OIL COMPANY LLC	1,832.93	
80131777	COLUMBIA ELECTRIC SUPPLY/DIV	595.53	
80131778	CONSOLIDATED SUPPLY CO	208,737.77	
80131779	CONTRACT DESIGN ASSOCIATES I	23,679.02	
80131780	COPIERS NORTHWEST INC	94.42	
80131781	CORE & MAIN LP	793.53	
80131782	CORRIDOR CONTRACTORS LLC	111,639.49	
80131783	DEER OAKS EAP SERVICES LLC	4,972.00	
80131784	DELL MARKETING LP	2,747.46	
80131785	EBSCO INFORMATION SERVICES		9.24
80131786	EUROFINS ENVIRONMENT TESTING	742.00	
80131787	EVCO SOUND & ELECTRONICS		649.64
80131788	FASTENAL CO	855.64	
80131789	FEDERAL EXPRESS CORP/DBA FED	197.72	
80131790	GORLEY LOGISTICS LLC	141.39	
80131791	FISHER SCIENTIFIC	6,181.96	
80131792	GRAINGER INC	1,650.01	
80131793	BECKWITH & KUFFEL INC DBA	379.87	
80131794	GROUP 4 ARCHITECTURE,RESEARC		37,568.88
80131795	HOME DEPOT USA INC	57.89	
80131796	INGRAM LIBRARY SERVICES LLC		96.47
80131797	CPM DEVELOPMENT CORP DBA	82,744.65	
80131798	INLAND ENVIRONMENTAL RESOURC	4,401.08	

REPORT: PG3640
SYSTEM: FMSAP
USER: MANAGER
RUN NO: 30

CITY OF SPOKANE
COUNCIL CHECK RANGE/TOTAL

DATE: 07/29/24
TIME: 10:06
PAGE: 6

CHECK #	VENDOR	CITY	LIBRARY	PARKS
80131799	INTEGRUS ARCHITECTURE	189,532.34		
80131800	KENWORTH SALES COMPANY	19,944.91		
80131801	LINN MACHINE & MFG	2,700.55		
80131802	LOOMIS ARMORED US INC	4,008.93		
80131803	MIDWEST TAPE		522.34	
80131804	NEPTUNE TECHNOLOGY GROUP INC	1,105.59		
80131805	NW MUSEUM OF ARTS & CULTURE/	604.95	5,000.00	
80131806	OLYMPIC FOUNDRY INC	6,512.76		
80131807	PAPE MACHINERY INC	27,560.73		
80131808	PETE LIEN & SONS INC	11,054.45		
80131809	POMP'S TIRE SERVICE INC	29,024.05		
80131810	RIVER PARK SQUARE LLC	1,000.00		
80131811	SPOKANE COUNTY TREASURER	172,610.73		

80131812	STAR RENTALS & SALES	77.11		
80131813	THOMAS SCIENTIFIC HOLDINGS L	1,385.66		
80131814	VERIZON WIRELESS	525.36	122.78	
80131815	WA STATE DEPT OF ECOLOGY	38,458.00		
80131816	WA STATE DEPT OF ECOLOGY	2,635.00		
80131817	CHRISTOPHER AVERYT	51.50		
80131818	ED HAIGHT SERVICE	209.83		
80131819	DENISE NEUJAHN		240.60	
80131820	AFLAC/AMERICAN FAMILY LIFE	15,163.80		
80131821	ALLWEST TESTING & ENGINEERIN			2,425.00
80131822	ALSCO DIVISION OF ALSCO INC			184.22
80131823	COLEMAN OIL COMPANY LLC			3,766.57
80131824	STEVE CONNER			24,882.85
80131825	COYLE OUTSIDE LLC			7,027.00
80131826	CREEK AT QUALCHAN GOLF COURS			20,908.61
80131827	ZERO TOLERANCE SNOW & ICE	430.55		
80131828	DELTA DENTAL OF WASHINGTON	54,891.34		
80131829	DESAUTEL HEGE COMMUNICATIONS			2,192.17
80131830	DIGNITARY PROTECTION TEAM FU	260.00		
80131831	EDU MEMBERSHIP FUND	15.00		
80131832	POLICE GUILD LEGAL DEFENSE	634.00		
80131833	HRA VEBA TRUST	59,371.50		
80131834	KAISER FOUNDATION HEALTH PLA	195,035.02		
80131835	LT & CAPT ASSOCIATION - LTD	747.50		
80131836	LTS & CPTS LEGAL DEFENSE FUN	46.00		
80131837	M & P ASSOCIATION	3,480.54		
80131838	NETWORK DESIGN & MGMNT INC	28,630.04		
80131839	PACIFIC GOLF TURF LLC			6,483.13
80131840	PLACE LANDSCAPE ARCHITECTURE			3,800.00
80131841	PLATEAU ARCHAEOLOGICAL			7,960.00
80131842	POWER TRANSPORT INC			600.00
80131843	PREMERA BLUE CROSS	73,762.28		
80131844	RAY TURF FARMS INC			544.50
80131845	REHN & ASSOCIATES	25,671.15		
80131846	SANDBAGGERS CLUB LLC			22,022.68
80131847	SPOKANE POLICE BENEFIT ASSOC	487.50		
80131848	SPOKANE POLICE CHAPLAIN	3,565.00		
80131849	SPOKANE POLICE K-9 MEMBERSHI	75.00		
80131850	SPOKANE POLICE GUILD LONG	20,670.00		
80131851	SPOKANE FIRE FIGHTERS BENEFI	70,834.54		

REPORT: PG3640
SYSTEM: FMSAP
USER: MANAGER
RUN NO: 30

CITY OF SPOKANE
COUNCIL CHECK RANGE/TOTAL

DATE: 07/29/24
TIME: 10:06
PAGE: 7

CHECK #	VENDOR	CITY	LIBRARY	PARKS
80131852	SPOKANE FIRE FIGHTERS BENEFI	817.80		
80131853	SPOKANE FIRE FIGHTERS BENEFI	832,920.00		
80131854	SPOKANE POLICE GUILD FRATERN	838.17		
80131855	W B SPRAGUE COMPANY INC			70.85
80131856	STANDARD INSURANCE COMPANY	13,462.20		
80131857	SPOKANE POLICE SWAT TEAM	420.00		
80131858	T & T GOLF MANAGEMENT INC			31,424.07
80131859	SPOKANE POLICE TACTICAL TEAM	608.00		
80131860	THE HUNTINGTON NATIONAL BANK			9,423.06
80131861	US BANK TRUST NA	1,166,138.14		
80131862	VERIZON WIRELESS	1,016.16		
80131863	WA ST COUNCIL OF CITY & COUN	31,941.20		
80131864	WESTERN EQUIPMENT DISTRIBUTO			21,624.63
80131865	WILDROSE LTD dba			364.93
80131866	WSCCCE, AFSCME, AFL-CIO	319.70		
		14,575,604.61	84,774.45	266,124.01

CITYWIDE TOTAL:

=====

14,926,503.07

0020 - NONDEPARTMENTAL

US BANK	EARNINGS CREDIT	
TREASURY MANAGEMENT SERVICES	CHECK NO. - 00604503	214.57-

TOTAL FOR 0020 - NONDEPARTMENTAL	214.57-
----------------------------------	---------

0030 - POLICE OMBUDSMAN

ICMA RETIREMENT TRUST 457	DEFERRED COMPENSATION-MATCHING	
% FIRST NATIONAL BANK OF MD	CHECK NO. - 00604593	275.00

US BANK OR CITY TREASURER	SOCIAL SECURITY	
EMP BENEFITS (CITY)	CHECK NO. - 00604603	1,052.63

US BANK TRUST NA	RETIREMENT	
OR CITY OF SPOKANE	ACH PMT NO. - 80131861	1,466.17

VERIZON WIRELESS	CELL PHONE	
	ACH PMT NO. - 80131759	128.28

TOTAL FOR 0030 - POLICE OMBUDSMAN	2,922.08
-----------------------------------	----------

0100 - GENERAL FUND

ACTION DRAIN & ROOTER WA LLC	PERMIT REFUNDS PAYABLE	
PO BOX 18718	CHECK NO. - 00604496	150.00

MAINSTREAM ELECTRIC LLC	PERMIT REFUNDS PAYABLE	
12822 E INDIANA AVE	CHECK NO. - 00604497	140.00

US BANK P CARD PAYMENTS	PCARD ADVANCE PYMT REC	
	ACH PMT NO. - 80131758	103,758.77

TOTAL FOR 0100 - GENERAL FUND	104,048.77
-------------------------------	------------

0230 - CIVIL SERVICE

ICMA RETIREMENT TRUST 457	DEFERRED COMPENSATION-MATCHING	
% FIRST NATIONAL BANK OF MD	CHECK NO. - 00604593	870.00

US BANK OR CITY TREASURER	SOCIAL SECURITY	
EMP BENEFITS (CITY)	CHECK NO. - 00604603	3,506.89

US BANK TRUST NA	RETIREMENT	
OR CITY OF SPOKANE	ACH PMT NO. - 80131861	5,045.82

TOTAL FOR 0230 - CIVIL SERVICE	9,422.71
--------------------------------	----------

0260 - CITY CLERK

HONORABLE MAYOR
AND COUNCIL MEMBERS

07/29/24
PAGE 3

PROCESSING OF VOUCHERS RESULTS IN CLAIMS AS FOLLOWS:

ICMA RETIREMENT TRUST 457	DEFERRED COMPENSATION-MATCHING	
% FIRST NATIONAL BANK OF MD	CHECK NO. - 00604593	340.00

US BANK OR CITY TREASURER EMP BENEFITS (CITY)	SOCIAL SECURITY CHECK NO. - 00604603	1,645.62
US BANK TRUST NA OR CITY OF SPOKANE	RETIREMENT ACH PMT NO. - 80131861	2,387.80
TOTAL FOR 0260 - CITY CLERK		4,373.42

0320 - COUNCIL

ICMA RETIREMENT TRUST 457 % FIRST NATIONAL BANK OF MD	DEFERRED COMPENSATION-MATCHING CHECK NO. - 00604593	1,110.00
US BANK OR CITY TREASURER EMP BENEFITS (CITY)	SOCIAL SECURITY CHECK NO. - 00604603	4,566.46
US BANK TRUST NA OR CITY OF SPOKANE	RETIREMENT ACH PMT NO. - 80131861	6,213.77
VERIZON WIRELESS	CELL PHONE ACH PMT NO. - 80131862	1,016.16
TOTAL FOR 0320 - COUNCIL		12,906.39

0330 - PUBLIC AFFAIRS/COMMUNICATIONS

ICMA RETIREMENT TRUST 457 % FIRST NATIONAL BANK OF MD	DEFERRED COMPENSATION-MATCHING CHECK NO. - 00604593	605.00
US BANK OR CITY TREASURER EMP BENEFITS (CITY)	SOCIAL SECURITY CHECK NO. - 00604603	2,894.93
US BANK TRUST NA OR CITY OF SPOKANE	RETIREMENT ACH PMT NO. - 80131861	3,642.02
TOTAL FOR 0330 - PUBLIC AFFAIRS/COMMUNICATIONS		7,141.95

0370 - ENGINEERING SERVICES

DELL MARKETING LP %DELL USA LP	MINOR EQUIPMENT ACH PMT NO. - 80131709	286.16
ICMA RETIREMENT TRUST 457 % FIRST NATIONAL BANK OF MD	DEFERRED COMPENSATION-MATCHING CHECK NO. - 00604593	3,259.00
PMTECH INC DBA PMWEB	CONTRACTUAL SERVICES ACH PMT NO. - 80131750	134.00
US BANK OR CITY TREASURER EMP BENEFITS (CITY)	SOCIAL SECURITY CHECK NO. - 00604603	15,917.64

HONORABLE MAYOR
AND COUNCIL MEMBERS

07/29/24
PAGE 4

PROCESSING OF VOUCHERS RESULTS IN CLAIMS AS FOLLOWS:

US BANK TRUST NA OR CITY OF SPOKANE	RETIREMENT ACH PMT NO. - 80131861	22,291.27
TOTAL FOR 0370 - ENGINEERING SERVICES		41,888.07

0410 - FINANCE

ICMA RETIREMENT TRUST 457	DEFERRED COMPENSATION-MATCHING	
% FIRST NATIONAL BANK OF MD	CHECK NO. - 00604593	725.00
LOOMIS ARMORED US INC	CONTRACTUAL SERVICES	
	ACH PMT NO. - 80131802	638.79
US BANK	BANK FEES	
TREASURY MANAGEMENT SERVICES	CHECK NO. - 00604503	3,057.92
US BANK	EARNINGS CREDIT	
TREASURY MANAGEMENT SERVICES	CHECK NO. - 00604503	1,411.97-
US BANK OR CITY TREASURER	SOCIAL SECURITY	
EMP BENEFITS (CITY)	CHECK NO. - 00604603	2,925.42
US BANK TRUST NA	RETIREMENT	
OR CITY OF SPOKANE	ACH PMT NO. - 80131861	4,175.64
TOTAL FOR 0410 - FINANCE		10,110.80

0450 - NEIGHBHD HOUSING HUMAN SVCS

ICMA RETIREMENT TRUST 457	DEFERRED COMPENSATION-MATCHING	
% FIRST NATIONAL BANK OF MD	CHECK NO. - 00604593	275.00
US BANK OR CITY TREASURER	SOCIAL SECURITY	
EMP BENEFITS (CITY)	CHECK NO. - 00604603	1,059.80
US BANK TRUST NA	RETIREMENT	
OR CITY OF SPOKANE	ACH PMT NO. - 80131861	1,548.36
TOTAL FOR 0450 - NEIGHBHD HOUSING HUMAN SVCS		2,883.16

0470 - HISTORIC PRESERVATION

ICMA RETIREMENT TRUST 457	DEFERRED COMPENSATION-MATCHING	
% FIRST NATIONAL BANK OF MD	CHECK NO. - 00604593	160.00
US BANK OR CITY TREASURER	SOCIAL SECURITY	
EMP BENEFITS (CITY)	CHECK NO. - 00604603	624.58
US BANK TRUST NA	RETIREMENT	
OR CITY OF SPOKANE	ACH PMT NO. - 80131861	887.13
TOTAL FOR 0470 - HISTORIC PRESERVATION		1,671.71

HONORABLE MAYOR
AND COUNCIL MEMBERS

07/29/24
PAGE 5

PROCESSING OF VOUCHERS RESULTS IN CLAIMS AS FOLLOWS:

0480 - OFFICE OF CIVIL RIGHTS

ICMA RETIREMENT TRUST 457	DEFERRED COMPENSATION-MATCHING	
% FIRST NATIONAL BANK OF MD	CHECK NO. - 00604593	75.00
US BANK OR CITY TREASURER	SOCIAL SECURITY	
EMP BENEFITS (CITY)	CHECK NO. - 00604603	643.50
US BANK TRUST NA	RETIREMENT	
OR CITY OF SPOKANE	ACH PMT NO. - 80131861	926.11

TOTAL FOR 0480 - OFFICE OF CIVIL RIGHTS 1,644.61

0500 - LEGAL

AVISTA UTILITIES	UTILITY LIGHT/POWER SERVICE ACH PMT NO. - 80131704	718.23
AVISTA UTILITIES	UTILITY NATURAL GAS ACH PMT NO. - 80131704	81.71
ICMA RETIREMENT TRUST 457 % FIRST NATIONAL BANK OF MD	DEFERRED COMPENSATION-MATCHING CHECK NO. - 00604593	1,915.00
ROAR WORKS LLC	LANDSCAPE/GROUNDS MAINT ACH PMT NO. - 80131727	1,019.15
US BANK OR CITY TREASURER EMP BENEFITS (CITY)	SOCIAL SECURITY CHECK NO. - 00604603	11,131.29
US BANK TRUST NA OR CITY OF SPOKANE	RETIREMENT ACH PMT NO. - 80131861	15,908.74
VERIZON WIRELESS	CELL PHONE ACH PMT NO. - 80131814	42.76

TOTAL FOR 0500 - LEGAL 30,816.88

0520 - MAYOR

ICMA RETIREMENT TRUST 457 % FIRST NATIONAL BANK OF MD	DEFERRED COMPENSATION-MATCHING CHECK NO. - 00604593	550.00
US BANK OR CITY TREASURER EMP BENEFITS (CITY)	SOCIAL SECURITY CHECK NO. - 00604603	2,719.93
US BANK TRUST NA OR CITY OF SPOKANE	RETIREMENT ACH PMT NO. - 80131861	3,227.08

TOTAL FOR 0520 - MAYOR 6,497.01

0550 - NEIGHBORHOOD SERVICES

HONORABLE MAYOR 07/29/24
AND COUNCIL MEMBERS PAGE 6

PROCESSING OF VOUCHERS RESULTS IN CLAIMS AS FOLLOWS:

AMBER GROE	LOCAL MILEAGE ACH PMT NO. - 80131699	41.81
ICMA RETIREMENT TRUST 457 % FIRST NATIONAL BANK OF MD	DEFERRED COMPENSATION-MATCHING CHECK NO. - 00604593	325.00
US BANK OR CITY TREASURER EMP BENEFITS (CITY)	SOCIAL SECURITY CHECK NO. - 00604603	1,914.41
US BANK TRUST NA OR CITY OF SPOKANE	RETIREMENT ACH PMT NO. - 80131861	1,644.28

TOTAL FOR 0550 - NEIGHBORHOOD SERVICES 3,925.50

0560 - MUNICIPAL COURT

ICMA RETIREMENT TRUST 457 % FIRST NATIONAL BANK OF MD	DEFERRED COMPENSATION-MATCHING CHECK NO. - 00604593	2,070.00
LOOMIS ARMORED US INC	CONTRACTUAL SERVICES ACH PMT NO. - 80131802	2,467.68
US BANK TREASURY MANAGEMENT SERVICES	BANK FEES CHECK NO. - 00604503	178.15
US BANK OR CITY TREASURER EMP BENEFITS (CITY)	SOCIAL SECURITY CHECK NO. - 00604603	9,910.61
US BANK TRUST NA OR CITY OF SPOKANE	RETIREMENT ACH PMT NO. - 80131861	14,505.15
TOTAL FOR 0560 - MUNICIPAL COURT		29,131.59

0570 - OFFICE OF HEARING EXAMINER

ICMA RETIREMENT TRUST 457 % FIRST NATIONAL BANK OF MD	DEFERRED COMPENSATION-MATCHING CHECK NO. - 00604593	101.00
US BANK OR CITY TREASURER EMP BENEFITS (CITY)	SOCIAL SECURITY CHECK NO. - 00604603	503.97
US BANK TRUST NA OR CITY OF SPOKANE	RETIREMENT ACH PMT NO. - 80131861	746.50
TOTAL FOR 0570 - OFFICE OF HEARING EXAMINER		1,351.47

0620 - HUMAN RESOURCES

ICMA RETIREMENT TRUST 457 % FIRST NATIONAL BANK OF MD	DEFERRED COMPENSATION-MATCHING CHECK NO. - 00604593	341.25
US BANK OR CITY TREASURER EMP BENEFITS (CITY)	SOCIAL SECURITY CHECK NO. - 00604603	2,557.95

HONORABLE MAYOR AND COUNCIL MEMBERS 07/29/24
PAGE 7

PROCESSING OF VOUCHERS RESULTS IN CLAIMS AS FOLLOWS:

US BANK TRUST NA OR CITY OF SPOKANE	RETIREMENT ACH PMT NO. - 80131861	3,007.26
TOTAL FOR 0620 - HUMAN RESOURCES		5,906.46

0650 - PLANNING SERVICES

ICMA RETIREMENT TRUST 457 % FIRST NATIONAL BANK OF MD	DEFERRED COMPENSATION-MATCHING CHECK NO. - 00604593	1,180.00
SIGNS FOR SUCCESS INC	PRINTING/BINDING/REPRO CREDIT CARD PMT NO. - 70000447	3,551.70
US BANK OR CITY TREASURER EMP BENEFITS (CITY)	SOCIAL SECURITY CHECK NO. - 00604603	4,936.35
US BANK TRUST NA	RETIREMENT	

OR CITY OF SPOKANE	ACH PMT NO. - 80131861	7,271.53
VERIZON WIRELESS	CELL PHONE ACH PMT NO. - 80131814	82.60
TOTAL FOR 0650 - PLANNING SERVICES		----- 17,022.18

0680 - POLICE

ALLIED ENVELOPE	PRINTING/BINDING/REPRO ACH PMT NO. - 80131767	428.30
ALTA LANGUAGE SERVICES INC	PROFESSIONAL SERVICES ACH PMT NO. - 80131701	110.00
ANTHONY LAMANNA	TUITION REIMBURSEMENT ACH PMT NO. - 80131764	1,988.00
AT&T MOBILITY	CELL PHONE CHECK NO. - 00604492	5,448.42
AVISTA UTILITIES	UTILITY LIGHT/POWER SERVICE ACH PMT NO. - 80131739	7,409.85
AVISTA UTILITIES	UTILITY NATURAL GAS ACH PMT NO. - 80131739	776.42
CAD OF SPOKANE, INC.	STRUCTURE REPAIRS/MAINTENANCE CHECK NO. - 00604562	2,604.24
CENTURYLINK	TELEPHONE CHECK NO. - 00604493	195.77
COMCAST	IT/DATA SERVICES CHECK NO. - 00604494	162.69
COPIERS NORTHWEST INC	EQUIPMENT REPAIRS/MAINTENANCE ACH PMT NO. - 80131708	16.82

HONORABLE MAYOR
AND COUNCIL MEMBERS

07/29/24
PAGE 8

PROCESSING OF VOUCHERS RESULTS IN CLAIMS AS FOLLOWS:

GALLS LLC	CLOTHING CREDIT CARD PMT NO. - 70000448	16,297.23
GALLS LLC	PROTECTIVE GEAR/CLOTHING CREDIT CARD PMT NO. - 70000435	14,744.99
GRAINGER INC	OPERATING SUPPLIES ACH PMT NO. - 80131717	331.78
GUNARAMA WHOLESALE INC	OPERATING SUPPLIES ACH PMT NO. - 80131745	38.47
ICMA RETIREMENT TRUST 457 % FIRST NATIONAL BANK OF MD	DEFERRED COMPENSATION-MATCHING CHECK NO. - 00604593	94,757.95
LEXIS-NEXIS RISK & ANALYTICS GROUP ACCURINT-ACCT 1189340	BACKGROUND CHECKS ACH PMT NO. - 80131721	163.50
PUBLIC SAFETY TESTING INC	PROFESSIONAL SERVICES CHECK NO. - 00604501	583.00
REHN & ASSOCIATES SPOKANE CITY TREASURER	HRA-POST EMPLOYMENT ACH PMT NO. - 80131845	1,000.00

SPOKANE COUNTY TREASURER	SPOKANE COUNTY ACH PMT NO. - 80131755	15,015.47
T-MOBILE USA INC	MISC SERVICES/CHARGES CHECK NO. - 00604482	100.00
US BANK TREASURY MANAGEMENT SERVICES	BANK FEES CHECK NO. - 00604503	185.75
US BANK TREASURY MANAGEMENT SERVICES	EARNINGS CREDIT CHECK NO. - 00604503	10.92-
US BANK OR CITY TREASURER EMP BENEFITS (CITY)	SOCIAL SECURITY CHECK NO. - 00604603	53,525.13
US BANK TRUST NA OR CITY OF SPOKANE	RETIREMENT ACH PMT NO. - 80131861	34,503.49
VERIZON WIRELESS	CELL PHONE ACH PMT NO. - 80131759	2,985.46
VERIZON WIRELESS	MOBILE BROADBAND ACH PMT NO. - 80131759	626.20
WA STATE CRIMINAL JUSTICE TRAINING COMMISSION	REGISTRATION/SCHOOLING ACH PMT NO. - 80131761	300.00
WA STATE EMPLOYMENT SECURITY PAID FAMILY MEDICAL LEAVE	WA PAID FAMILY & MEDICAL LEAVE CHECK NO. - 00604486	29.66
WASHINGTON LEOFF DEPT OF RETIREMENT SYSTEMS	PENSION LEOFF II CHECK NO. - 00604607	216,490.41
WESTERN STATES POLICE MEDICAL TRUST	VEBA MEDICAL SAVINGS-POLICE CHECK NO. - 00604609	2,362.50

HONORABLE MAYOR
AND COUNCIL MEMBERS

07/29/24
PAGE 9

PROCESSING OF VOUCHERS RESULTS IN CLAIMS AS FOLLOWS:

TOTAL FOR 0680 - POLICE		----- 473,170.58
0690 - COMMUNITY JUSTICE SERVICES		
ICMA RETIREMENT TRUST 457 % FIRST NATIONAL BANK OF MD	DEFERRED COMPENSATION-MATCHING CHECK NO. - 00604593	1,415.00
US BANK OR CITY TREASURER EMP BENEFITS (CITY)	SOCIAL SECURITY CHECK NO. - 00604603	6,173.09
US BANK TRUST NA OR CITY OF SPOKANE	RETIREMENT ACH PMT NO. - 80131861	9,108.46
TOTAL FOR 0690 - COMMUNITY JUSTICE SERVICES		----- 16,696.55
0700 - PUBLIC DEFENDER		
AVISTA UTILITIES	UTILITY LIGHT/POWER SERVICE ACH PMT NO. - 80131704	718.23
AVISTA UTILITIES	UTILITY NATURAL GAS ACH PMT NO. - 80131704	81.70

GORLEY LOGISTICS LLC dba FIKES NORTHWEST	OPERATING SUPPLIES ACH PMT NO. - 80131716	16.64
ICMA RETIREMENT TRUST 457 % FIRST NATIONAL BANK OF MD	DEFERRED COMPENSATION-MATCHING CHECK NO. - 00604593	1,306.00
ROAR WORKS LLC	LANDSCAPE/GROUNDS MAINT ACH PMT NO. - 80131727	1,019.15
US BANK OR CITY TREASURER EMP BENEFITS (CITY)	SOCIAL SECURITY CHECK NO. - 00604603	7,532.10
US BANK TRUST NA OR CITY OF SPOKANE	RETIREMENT ACH PMT NO. - 80131861	10,491.00

TOTAL FOR 0700 - PUBLIC DEFENDER		21,164.82

0750 - COMMUNITY/ECONOMIC DEV SVC

ICMA RETIREMENT TRUST 457 % FIRST NATIONAL BANK OF MD	DEFERRED COMPENSATION-MATCHING CHECK NO. - 00604593	175.00
US BANK OR CITY TREASURER EMP BENEFITS (CITY)	SOCIAL SECURITY CHECK NO. - 00604603	743.49
US BANK TRUST NA OR CITY OF SPOKANE	RETIREMENT ACH PMT NO. - 80131861	1,084.33
VERIZON WIRELESS	CELL PHONE ACH PMT NO. - 80131814	52.40

HONORABLE MAYOR
AND COUNCIL MEMBERS

07/29/24
PAGE 10

PROCESSING OF VOUCHERS RESULTS IN CLAIMS AS FOLLOWS:

TOTAL FOR 0750 - COMMUNITY/ECONOMIC DEV SVC		2,055.22

1100 - STREET FUND

AVISTA UTILITIES	UTILITY LIGHT/POWER SERVICE ACH PMT NO. - 80131771	43.02
CPM DEVELOPMENT CORP DBA INLAND ASPHALT COMPANY	REPAIR & MAINTENANCE SUPPLIES ACH PMT NO. - 80131797	82,744.65
ENNIS FLINT INC	REPAIR & MAINTENANCE SUPPLIES ACH PMT NO. - 80131673	22,710.16
FASTENAL CO	OPERATING SUPPLIES ACH PMT NO. - 80131788	347.42
ICMA RETIREMENT TRUST 457 % FIRST NATIONAL BANK OF MD	DEFERRED COMPENSATION-MATCHING CHECK NO. - 00604593	4,811.00
METROPOLITAN TRANSPORTATION COMMISSION	SOFTWARE (NONCAPITALIZED) CHECK NO. - 00604582	9,000.00
STAR RENTALS & SALES	OPERATING RENTALS/LEASES ACH PMT NO. - 80131812	77.11
US BANK OR CITY TREASURER EMP BENEFITS (CITY)	SOCIAL SECURITY CHECK NO. - 00604603	21,623.56
US BANK TRUST NA	RETIREMENT	

OR CITY OF SPOKANE ACH PMT NO. - 80131861 30,477.34

TOTAL FOR 1100 - STREET FUND 171,834.26

1200 - CODE ENFORCEMENT FUND

CLARK'S CONTAINERS LLC	OPERATING RENTALS/LEASES ACH PMT NO. - 80131666	232.72
ICMA RETIREMENT TRUST 457 % FIRST NATIONAL BANK OF MD	DEFERRED COMPENSATION-MATCHING CHECK NO. - 00604593	1,155.00
RYAN MILLER	MEDICAL SERVICES ACH PMT NO. - 80131765	60.00
RYAN MILLER	PERMITS/OTHER FEES ACH PMT NO. - 80131765	90.00
US BANK OR CITY TREASURER EMP BENEFITS (CITY)	SOCIAL SECURITY CHECK NO. - 00604603	4,904.14
US BANK TRUST NA OR CITY OF SPOKANE	RETIREMENT ACH PMT NO. - 80131861	7,283.78

TOTAL FOR 1200 - CODE ENFORCEMENT FUND 13,725.64

HONORABLE MAYOR
AND COUNCIL MEMBERS

07/29/24
PAGE 11

PROCESSING OF VOUCHERS RESULTS IN CLAIMS AS FOLLOWS:

1300 - LIBRARY FUND

ICMA RETIREMENT TRUST 457 % FIRST NATIONAL BANK OF MD	DEFERRED COMPENSATION-MATCHING CHECK NO. - 00604593	2,880.00
US BANK TREASURY MANAGEMENT SERVICES	BANK FEES CHECK NO. - 00604503	234.96
US BANK TREASURY MANAGEMENT SERVICES	EARNINGS CREDIT CHECK NO. - 00604503	12.77-
US BANK OR CITY TREASURER EMP BENEFITS (CITY)	SOCIAL SECURITY CHECK NO. - 00604603	21,326.26
US BANK TRUST NA OR CITY OF SPOKANE	RETIREMENT ACH PMT NO. - 80131861	28,727.43

TOTAL FOR 1300 - LIBRARY FUND 53,155.88

1360 - MISCELLANEOUS GRANTS FUND

KELSEY DELONG DBA HELIOS HOUSING LLC	OTHER MISC CHARGES CHECK NO. - 00604470	338.70
OXFORD HOUSE COOK STREET	OTHER MISC CHARGES CHECK NO. - 00604479	233.34

TOTAL FOR 1360 - MISCELLANEOUS GRANTS FUND 572.04

1380 - TRAFFIC CALMING MEASURES

INLAND INFRASTRUCTURE LLC	CONSTRUCTION OF FIXED ASSETS ACH PMT NO. - 80131746	362,185.05
JACOB WOLFF 5814 E CUSTER LN	SCHOOL ZONE SPEED CAMERA FINE CHECK NO. - 00604500	18.00
LINDA CAROTHERS OR SELENA ALVAREZ	SCHOOL ZONE SPEED CAMERA FINE CHECK NO. - 00604499	10.00
ROBERT AND ROSALIE WOOD 2624 N ALTAMONT ST	SCHOOL ZONE SPEED CAMERA FINE CHECK NO. - 00604498	25.00
US BANK OR CITY TREASURER EMP BENEFITS (CITY)	SOCIAL SECURITY CHECK NO. - 00604603	251.93
US BANK TRUST NA OR CITY OF SPOKANE	RETIREMENT ACH PMT NO. - 80131861	362.74
TOTAL FOR 1380 - TRAFFIC CALMING MEASURES		362,852.72

1390 - URBAN FORESTRY FUND

HONORABLE MAYOR
AND COUNCIL MEMBERS

07/29/24
PAGE 12

PROCESSING OF VOUCHERS RESULTS IN CLAIMS AS FOLLOWS:

ICMA RETIREMENT TRUST 457 % FIRST NATIONAL BANK OF MD	DEFERRED COMPENSATION-MATCHING CHECK NO. - 00604593	50.00
US BANK OR CITY TREASURER EMP BENEFITS (CITY)	SOCIAL SECURITY CHECK NO. - 00604603	206.85
US BANK TRUST NA OR CITY OF SPOKANE	RETIREMENT ACH PMT NO. - 80131861	299.11
TOTAL FOR 1390 - URBAN FORESTRY FUND		555.96

1400 - PARKS AND RECREATION FUND

ICMA RETIREMENT TRUST 457 % FIRST NATIONAL BANK OF MD	DEFERRED COMPENSATION-MATCHING CHECK NO. - 00604593	5,011.00
KAISER FOUNDATION HEALTH OF WASHINGTON	BACKGROUND CHECKS CHECK NO. - 00604596	260.00
US BANK TREASURY MANAGEMENT SERVICES	BANK FEES CHECK NO. - 00604503	354.79
US BANK OR CITY TREASURER EMP BENEFITS (CITY)	SOCIAL SECURITY CHECK NO. - 00604603	45,255.33
US BANK TRUST NA OR CITY OF SPOKANE	RETIREMENT ACH PMT NO. - 80131861	31,891.63
TOTAL FOR 1400 - PARKS AND RECREATION FUND		82,772.75

1425 - AMERICAN RESCUE PLAN

GRANICUS LLC	SUBSCRIPTION BASED IT ARNGMTS ACH PMT NO. - 80131679	51,630.25
--------------	---	-----------

US BANK OR CITY TREASURER EMP BENEFITS (CITY)	SOCIAL SECURITY CHECK NO. - 00604603	173.09
VOLT MANAGEMENT CORP DBA VOLT WORKFORCE SOLUTIONS	CONTRACTUAL SERVICES ACH PMT NO. - 80131732	9,506.86
WILLAR CORP dba JOHNSTONE SUPPLY	MISC REPAIRS/MAINTENANCE ACH PMT NO. - 80131747	3,275.94
TOTAL FOR 1425 - AMERICAN RESCUE PLAN		64,586.14

1460 - PARKING METER REVENUE FUND

COPIERS NORTHWEST INC	OPERATING RENTALS/LEASES ACH PMT NO. - 80131669	143.55
ICMA RETIREMENT TRUST 457 % FIRST NATIONAL BANK OF MD	DEFERRED COMPENSATION-MATCHING CHECK NO. - 00604593	785.00

HONORABLE MAYOR
AND COUNCIL MEMBERS

07/29/24
PAGE 13

PROCESSING OF VOUCHERS RESULTS IN CLAIMS AS FOLLOWS:

LOOMIS ARMORED US INC	CONTRACTUAL SERVICES ACH PMT NO. - 80131802	902.46
US BANK TREASURY MANAGEMENT SERVICES	BANK FEES CHECK NO. - 00604503	539.01
US BANK OR CITY TREASURER EMP BENEFITS (CITY)	SOCIAL SECURITY CHECK NO. - 00604603	2,972.12
US BANK TRUST NA OR CITY OF SPOKANE	RETIREMENT ACH PMT NO. - 80131861	4,294.66
TOTAL FOR 1460 - PARKING METER REVENUE FUND		9,636.80

1560 - FORFEITURES & CONTRIBUTION FND

WA STATE DEPT OF LICENSING SPOKANE COUNTY COURTHOUSE	MISC SERVICES/CHARGES CHECK NO. - 00604584	378.00
TOTAL FOR 1560 - FORFEITURES & CONTRIBUTION FND		378.00

1620 - PUBLIC SAFETY & JUDICIAL GRANT

ICMA RETIREMENT TRUST 457 % FIRST NATIONAL BANK OF MD	DEFERRED COMPENSATION-MATCHING CHECK NO. - 00604593	1,072.67
US BANK OR CITY TREASURER EMP BENEFITS (CITY)	SOCIAL SECURITY CHECK NO. - 00604603	339.63
WASHINGTON LEOFF DEPT OF RETIREMENT SYSTEMS	PENSION LEOFF II CHECK NO. - 00604607	2,361.42
TOTAL FOR 1620 - PUBLIC SAFETY & JUDICIAL GRANT		3,773.72

1625 - PUBLIC SAFETY PERSONNEL FUND

ICMA RETIREMENT TRUST 457	DEFERRED COMPENSATION-MATCHING
---------------------------	--------------------------------

% FIRST NATIONAL BANK OF MD	CHECK NO. - 00604593	3,258.42
ING LIFE INSURANCE & ANNUITY OR CITY OF SPOKANE TREASURER	DEFERRED COMPENSATION-MATCHING CHECK NO. - 00604595	4,462.87
US BANK OR CITY TREASURER EMP BENEFITS (CITY)	SOCIAL SECURITY CHECK NO. - 00604603	5,095.59
US BANK TRUST NA OR CITY OF SPOKANE	RETIREMENT ACH PMT NO. - 80131861	4,051.43
WASHINGTON LEOFF DEPT OF RETIREMENT SYSTEMS	PENSION LEOFF II CHECK NO. - 00604607	17,884.75
TOTAL FOR 1625 - PUBLIC SAFETY PERSONNEL FUND		34,753.06

HONORABLE MAYOR
AND COUNCIL MEMBERS

07/29/24
PAGE 14

PROCESSING OF VOUCHERS RESULTS IN CLAIMS AS FOLLOWS:

1640 - COMMUNICATIONS BLDG M&O FUND

CENTURYLINK	TELEPHONE CHECK NO. - 00604468	91.82
TOTAL FOR 1640 - COMMUNICATIONS BLDG M&O FUND		91.82

1680 - CD/HS OPERATIONS

ICMA RETIREMENT TRUST 457 % FIRST NATIONAL BANK OF MD	DEFERRED COMPENSATION-MATCHING CHECK NO. - 00604593	974.76
US BANK OR CITY TREASURER EMP BENEFITS (CITY)	SOCIAL SECURITY CHECK NO. - 00604603	5,422.60
US BANK TRUST NA OR CITY OF SPOKANE	RETIREMENT ACH PMT NO. - 80131861	7,010.99
TOTAL FOR 1680 - CD/HS OPERATIONS		13,408.35

1910 - CRIMINAL JUSTICE ASSISTANCE FD

ICMA RETIREMENT TRUST 457 % FIRST NATIONAL BANK OF MD	DEFERRED COMPENSATION-MATCHING CHECK NO. - 00604593	75.00
NONICA ANDREW DBA MARSHALLESE INTERPRETING SERVICES	INTERPRETER COSTS ACH PMT NO. - 80131722	3,213.00
US BANK OR CITY TREASURER EMP BENEFITS (CITY)	SOCIAL SECURITY CHECK NO. - 00604603	183.04
US BANK TRUST NA OR CITY OF SPOKANE	RETIREMENT ACH PMT NO. - 80131861	270.60
TOTAL FOR 1910 - CRIMINAL JUSTICE ASSISTANCE FD		3,741.64

1970 - FIRE/EMS FUND

AT&T MOBILITY	CELL PHONE CHECK NO. - 00604467	12.43
---------------	------------------------------------	-------

CANYON BUFFS APTS 2610 W WESTWOOD LN	PERMIT REFUNDS PAYABLE CHECK NO. - 00604475	44.00
CAR WASH PARTNERS LLC DBA MR CAR WASH	VEHICLE REPAIRS/MAINT ACH PMT NO. - 80131723	220.00
CENTURYLINK	TELEPHONE CHECK NO. - 00604468	451.21
CHICK-FIL-A ATTN: ZACK BRAEM	PERMIT REFUNDS PAYABLE CHECK NO. - 00604474	210.00

HONORABLE MAYOR
AND COUNCIL MEMBERS

07/29/24
PAGE 15

PROCESSING OF VOUCHERS RESULTS IN CLAIMS AS FOLLOWS:

COLEMAN OIL COMPANY LLC	MOTOR FUEL-OUTSIDE VENDOR ACH PMT NO. - 80131707	9,992.76
GALLS LLC	CLOTHING CREDIT CARD PMT NO. - 70000435	676.01
GRAPETREE MIXED USE C/O GOODALE & BARBIERI CO	PERMIT REFUNDS PAYABLE CHECK NO. - 00604476	38.00
HOLIDAY INN SPOKANE 595 JEAN RD STE 100	PERMIT REFUNDS PAYABLE CHECK NO. - 00604477	38.00
ICCU ATTN: ACCOUNTING	PERMIT REFUNDS PAYABLE CHECK NO. - 00604478	76.00
ICMA RETIREMENT TRUST 457 % FIRST NATIONAL BANK OF MD	DEFERRED COMPENSATION-MATCHING CHECK NO. - 00604593	10,049.43
ING LIFE INSURANCE & ANNUITY OR CITY OF SPOKANE TREASURER	DEFERRED COMPENSATION-MATCHING CHECK NO. - 00604595	54,024.92
KAISER FOUNDATION HEALTH OF WASHINGTON	MEDICAL SERVICES CHECK NO. - 00604454	7,383.00
KBG DEVELOPMENTS LLC DBA TOWNS LIQUOR MART	MOTOR FUEL-OUTSIDE VENDOR ACH PMT NO. - 80131720	63.72
KEVIN M SMITH	LODGING ACH PMT NO. - 80131737	121.84
KEVIN M SMITH	OTHER TRANSPORTATION EXPENSES ACH PMT NO. - 80131737	253.26
KEVIN M SMITH	PER DIEM ACH PMT NO. - 80131737	160.00
SPOKANE FIRE FIGHTERS BENEFIT TRUST	VEBA POST EMPLOYMENT ACH PMT NO. - 80131853	16,500.00
US BANK TREASURY MANAGEMENT SERVICES	BANK FEES CHECK NO. - 00604503	188.53
US BANK OR CITY TREASURER EMP BENEFITS (CITY)	SOCIAL SECURITY CHECK NO. - 00604603	32,661.03
US BANK TRUST NA OR CITY OF SPOKANE	RETIREMENT ACH PMT NO. - 80131861	9,381.08
WASHINGTON LEOFF DEPT OF RETIREMENT SYSTEMS	PENSION LEOFF II CHECK NO. - 00604607	200,938.54

YP AUTOMOTIVE INC	VEHICLE REPAIR & MAINT SUPPLY	
DBA GMC OF RIVERFRONT PARK	CHECK NO. - 00604469	162.42

TOTAL FOR 1970 - FIRE/EMS FUND		343,646.18
--------------------------------	--	------------

1990 - TRANSPORTATION BENEFIT FUND

HONORABLE MAYOR	07/29/24
AND COUNCIL MEMBERS	PAGE 16

PROCESSING OF VOUCHERS RESULTS IN CLAIMS AS FOLLOWS:

SHAMROCK PAVING CO/DIV OF	CONTRACTUAL SERVICES	
MURPHY BROS INC	ACH PMT NO. - 80131753	846,784.92

TOTAL FOR 1990 - TRANSPORTATION BENEFIT FUND		846,784.92
--	--	------------

3200 - ARTERIAL STREET FUND

CORRIDOR CONTRACTORS LLC	CONSTRUCTION OF FIXED ASSETS	
	ACH PMT NO. - 80131782	95,789.17

INLAND INFRASTRUCTURE LLC	CONSTRUCTION OF FIXED ASSETS	
	ACH PMT NO. - 80131746	30,951.23

SHAMROCK PAVING CO/DIV OF	CONSTRUCTION OF FIXED ASSETS	
MURPHY BROS INC	ACH PMT NO. - 80131753	522,952.52

SPOKANE COUNTY TITLE CO	RIGHT OF WAY	
	CHECK NO. - 00604481	253,772.54

WA STATE DEPT/TRANSPORTATION	CONSTRUCTION OF FIXED ASSETS	
	ACH PMT NO. - 80131733	222.50

TOTAL FOR 3200 - ARTERIAL STREET FUND		903,687.96
---------------------------------------	--	------------

4100 - WATER DIVISION

BRETT E BURRIS	REFUNDS	
PO BOX 473	CHECK NO. - 00604567	228.52

CONSOLIDATED SUPPLY CO	INVENTORY PURCHASES FOR WATER	
	ACH PMT NO. - 80131778	208,737.77

CORE & MAIN LP	INVENTORY PURCHASES FOR WATER	
	ACH PMT NO. - 80131781	793.53

CORRECT EQUIPMENT INC	CHEMICAL/LAB SUPPLIES	
	ACH PMT NO. - 80131670	4,977.20

ESTATE OF MARCIA LOOSMORE	REFUNDS	
PO BOX 100	CHECK NO. - 00604568	50.00

EVANS ENGINEERING AND	CONSTRUCTION OF FIXED ASSETS	
CONSULTING PLLC	CHECK NO. - 00604453	1,158.75

FASTENAL CO	REPAIR & MAINTENANCE SUPPLIES	
	ACH PMT NO. - 80131674	74.99

HORNBERGER PROPERTY MANAGEMENT	REFUNDS	
112 UNIVERSITY RD	CHECK NO. - 00604569	1,644.71

ICMA RETIREMENT TRUST 457	DEFERRED COMPENSATION-MATCHING	
---------------------------	--------------------------------	--

% FIRST NATIONAL BANK OF MD	CHECK NO. - 00604593	8,265.00
INTEGRUS ARCHITECTURE	CONSTRUCTION OF FIXED ASSETS ACH PMT NO. - 80131799	189,532.34

HONORABLE MAYOR
AND COUNCIL MEMBERS

07/29/24
PAGE 17

PROCESSING OF VOUCHERS RESULTS IN CLAIMS AS FOLLOWS:

NEPTUNE TECHNOLOGY GROUP INC	MACHINERY/EQUIPMENT ACH PMT NO. - 80131804	1,105.59
OLYMPIC FOUNDRY INC	INVENTORY PURCHASES FOR WATER ACH PMT NO. - 80131806	6,512.76
PAM CAMERON 11618 E 19TH AVE	REFUNDS CHECK NO. - 00604570	49.41
PATRICK AND MICHELE MOORE 5430 N DRISCOLL BLVD	REFUNDS CHECK NO. - 00604571	128.95
RYAN ASKER 12020 E MARIETTA AVE	REFUNDS CHECK NO. - 00604572	20.15
RYAN CRISMAN 8614 LANGPORT DR	REFUNDS CHECK NO. - 00604573	116.52
THE IMPERIAL APTS LLC 120 W 3RD AVE	REFUNDS CHECK NO. - 00604574	134.94
US BANK OR CITY TREASURER EMP BENEFITS (CITY)	SOCIAL SECURITY CHECK NO. - 00604603	39,032.77
US BANK TRUST NA OR CITY OF SPOKANE	RETIREMENT ACH PMT NO. - 80131861	55,791.85
WATSON MANAGEMENT 102 E BALDWIN AVE	REFUNDS CHECK NO. - 00604575	316.40
WHITE BLOCK COMPANY INC	REPAIR & MAINTENANCE SUPPLIES CHECK NO. - 00604587	961.51
TOTAL FOR 4100 - WATER DIVISION		519,633.66

4250 - INTEGRATED CAPITAL MANAGEMENT

BUDINGER & ASSOCIATES INC	CONSTRUCTION OF FIXED ASSETS ACH PMT NO. - 80131741	1,799.72
CORRIDOR CONTRACTORS LLC	CONSTRUCTION OF FIXED ASSETS ACH PMT NO. - 80131782	15,850.32
GHD INC	CONSTRUCTION OF FIXED ASSETS ACH PMT NO. - 80131743	63,683.75
GROUNDWATER SOLUTIONS INC dba GSI WATER SOLUTIONS INC	CONSTRUCTION OF FIXED ASSETS ACH PMT NO. - 80131744	20,105.91
ICMA RETIREMENT TRUST 457 % FIRST NATIONAL BANK OF MD	DEFERRED COMPENSATION-MATCHING CHECK NO. - 00604593	905.00
LEGEND INVESTMENTS CORP DBA NATIONAL BARRICADE CO OF	CONSTRUCTION OF FIXED ASSETS ACH PMT NO. - 80131749	816.75
PMTECH INC DBA PMWEB	CONTRACTUAL SERVICES ACH PMT NO. - 80131750	66.00

PROCESSING OF VOUCHERS RESULTS IN CLAIMS AS FOLLOWS:

US BANK OR CITY TREASURER EMP BENEFITS (CITY)	SOCIAL SECURITY CHECK NO. - 00604603	4,731.83
US BANK TRUST NA OR CITY OF SPOKANE	RETIREMENT ACH PMT NO. - 80131861	6,681.75
TOTAL FOR 4250 - INTEGRATED CAPITAL MANAGEMENT		114,641.03

4310 - SEWER MAINTENANCE DIVISION

ICMA RETIREMENT TRUST 457 % FIRST NATIONAL BANK OF MD	DEFERRED COMPENSATION-MATCHING CHECK NO. - 00604593	2,470.00
US BANK OR CITY TREASURER EMP BENEFITS (CITY)	SOCIAL SECURITY CHECK NO. - 00604603	11,064.31
US BANK TRUST NA OR CITY OF SPOKANE	RETIREMENT ACH PMT NO. - 80131861	16,224.12
TOTAL FOR 4310 - SEWER MAINTENANCE DIVISION		29,758.43

4320 - RIVERSIDE PARK RECLAMATION FAC

ALS LABORATORY GROUP	TESTING SERVICES ACH PMT NO. - 80131661	2,380.00
BATTERY SYSTEMS INC	OPERATING SUPPLIES ACH PMT NO. - 80131773	3,436.56
BECKWITH & KUFFEL INC DBA GRANICH ENGINEERED PRODUCTS	OPERATING SUPPLIES ACH PMT NO. - 80131793	379.87
BROWN AND CALDWELL	PROFESSIONAL SERVICES ACH PMT NO. - 80131740	1,384.61
CENTURYLINK	TELEPHONE CHECK NO. - 00604452	8,543.91
COLEMAN OIL COMPANY LLC	MOTOR FUEL-OUTSIDE VENDOR ACH PMT NO. - 80131776	1,832.93
COLUMBIA ELECTRIC SUPPLY/DIV CONSOLIDATED ELECTRICAL	OPERATING SUPPLIES ACH PMT NO. - 80131777	595.53
ELJAY OIL CO INC	LUBRICANTS CREDIT CARD PMT NO. - 70000430	1,253.50
ENDRESS+HAUSER INC C/O FIELD INSTRUMENTS & CONTRO	OPERATING SUPPLIES CREDIT CARD PMT NO. - 70000444	2,703.55
EUROFINS ENVIRONMENT TESTING NORTHWEST LLC	TESTING SERVICES ACH PMT NO. - 80131786	924.50
EVOQUA WATER TECHNOLOGIES LLC	EQUIPMENT REPAIRS/MAINTENANCE ACH PMT NO. - 80131713	743.92

PROCESSING OF VOUCHERS RESULTS IN CLAIMS AS FOLLOWS:

FEDERAL EXPRESS CORP/DBA FEDEX	POSTAGE ACH PMT NO. - 80131789	197.72
FISHER SCIENTIFIC	OPERATING SUPPLIES ACH PMT NO. - 80131791	8,697.46
GOBLE SAMPSON ASSOCIATES	REPAIR & MAINTENANCE SUPPLIES ACH PMT NO. - 80131678	4,501.70
GORLEY LOGISTICS LLC dba FIKES NORTHWEST	LAUNDRY/JANITORIAL SERVICES ACH PMT NO. - 80131790	58.22
HASA INC	CHEMICAL/LAB SUPPLIES ACH PMT NO. - 80131680	15,620.92
HUBER TECHNOLOGY INC	OPERATING SUPPLIES ACH PMT NO. - 80131719	3,659.24
ICMA RETIREMENT TRUST 457 % FIRST NATIONAL BANK OF MD	DEFERRED COMPENSATION-MATCHING CHECK NO. - 00604593	6,675.01
INLAND ENVIRONMENTAL RESOURCES INC	CHEMICAL/LAB SUPPLIES ACH PMT NO. - 80131798	11,925.98
INLAND POWER & LIGHT CO	UTILITY LIGHT/POWER SERVICE ACH PMT NO. - 80131682	91.64
KEMIRA WATER SOLUTIONS INC	CHEMICAL/LAB SUPPLIES ACH PMT NO. - 80131683	82,547.21
MCKINSTRY CO LLC LOCKBOX	EQUIPMENT REPAIRS/MAINTENANCE ACH PMT NO. - 80131685	4,546.14
NORCO INC	OPERATING SUPPLIES CREDIT CARD PMT NO. - 70000431	617.38
OTIS ELEVATOR COMPANY	BUILDING REPAIRS/MAINTENANCE ACH PMT NO. - 80131725	456.70
POLYDYNE INC	CHEMICAL/LAB SUPPLIES CREDIT CARD PMT NO. - 70000433	9,172.36
SMARTSIGHTS TECHNOLOGIES LLC DBA SMARTSIGHTS LLC	SOFTWARE (NONCAPITALIZED) ACH PMT NO. - 80131690	4,905.00
SPECIALTY ANALYTICAL	TESTING SERVICES CHECK NO. - 00604581	280.00
THOMAS SCIENTIFIC HOLDINGS LLC DBA THOMAS SCIENTIFIC INC	OPERATING SUPPLIES ACH PMT NO. - 80131813	1,385.66
TWO RIVERS TERMINAL LLC	CHEMICAL/LAB SUPPLIES ACH PMT NO. - 80131729	21,337.98
UNITED STATES GEOLOGICAL SURVEY	OTH DUES/SUBSCRIPTNS/MEMBERSHP CHECK NO. - 00604461	5,306.00
US BANK OR CITY TREASURER EMP BENEFITS (CITY)	SOCIAL SECURITY CHECK NO. - 00604603	31,948.19

HONORABLE MAYOR
AND COUNCIL MEMBERS

07/29/24
PAGE 20

PROCESSING OF VOUCHERS RESULTS IN CLAIMS AS FOLLOWS:

US BANK TRUST NA RETIREMENT

OR CITY OF SPOKANE	ACH PMT NO. - 80131861	46,969.66
WA STATE DEPT OF ECOLOGY	PERMITS/OTHER FEES ACH PMT NO. - 80131734	221,960.50
TOTAL FOR 4320 - RIVERSIDE PARK RECLAMATION FAC		507,039.55

4330 - STORMWATER

CENTURYLINK	TELEPHONE CHECK NO. - 00604452	2,233.21
ICMA RETIREMENT TRUST 457 % FIRST NATIONAL BANK OF MD	DEFERRED COMPENSATION-MATCHING CHECK NO. - 00604593	1,545.00
NB ENGINEERING LLC DBA EVERGREEN STORMH2O	CONTRACTUAL SERVICES ACH PMT NO. - 80131686	10,623.00
ROGUE HEART MEDIA SPC	CONTRACTUAL SERVICES ACH PMT NO. - 80131688	3,981.75
US BANK OR CITY TREASURER EMP BENEFITS (CITY)	SOCIAL SECURITY CHECK NO. - 00604603	5,953.12
US BANK TRUST NA OR CITY OF SPOKANE	RETIREMENT ACH PMT NO. - 80131861	8,566.33
WA STATE DEPT OF ECOLOGY CASHERING UNIT	PERMITS/OTHER FEES ACH PMT NO. - 80131815	38,458.00
ZERO TOLERANCE SNOW & ICE SOLUTIONS LLC	CONTRACTUAL SERVICES ACH PMT NO. - 80131827	430.55
TOTAL FOR 4330 - STORMWATER		71,790.96

4360 - ENVIRONMENTAL PROGRAMS

ICMA RETIREMENT TRUST 457 % FIRST NATIONAL BANK OF MD	DEFERRED COMPENSATION-MATCHING CHECK NO. - 00604593	150.00
US BANK OR CITY TREASURER EMP BENEFITS (CITY)	SOCIAL SECURITY CHECK NO. - 00604603	621.12
US BANK TRUST NA OR CITY OF SPOKANE	RETIREMENT ACH PMT NO. - 80131861	920.74
TOTAL FOR 4360 - ENVIRONMENTAL PROGRAMS		1,691.86

4490 - SOLID WASTE DISPOSAL

AIRGAS SPECIALTY PRODUCTS INC	CHEMICAL/LAB SUPPLIES CREDIT CARD PMT NO. - 70000428	45,297.99
-------------------------------	---	-----------

HONORABLE MAYOR
AND COUNCIL MEMBERS

07/29/24
PAGE 21

PROCESSING OF VOUCHERS RESULTS IN CLAIMS AS FOLLOWS:

AVISTA UTILITIES	UTILITY LIGHT/POWER SERVICE ACH PMT NO. - 80131771	436.22
AVISTA UTILITIES	UTILITY NATURAL GAS ACH PMT NO. - 80131662	782.23

BARR-TECH LLC	CONTRACTUAL SERVICES ACH PMT NO. - 80131663	35,993.90
BENDER CCP INC	EQUIPMENT REPAIRS/MAINTENANCE ACH PMT NO. - 80131698	130,745.50
BIG SKY INDUSTRIAL/DIV OF ROCHELLE CONSTRUCTION SERVICES	EQUIPMENT REPAIRS/MAINTENANCE CHECK NO. - 00604450	46,778.90
BRANDSAFWAY SERVICES INC	EQUIPMENT REPAIRS/MAINTENANCE ACH PMT NO. - 80131689	9,933.23
BROADWAY TRUCK STOP/DIV OF ALSAKER CORP	MOTOR FUEL-OUTSIDE VENDOR CHECK NO. - 00604561	248.30
C & C YARD CARE	LANDSCAPE/GROUNDS MAINT ACH PMT NO. - 80131664	1,240.97
CENTURYLINK	TELEPHONE CHECK NO. - 00604564	75.12
CHRISTOPHER AVERYT	PARKING/TOLLS (LOCAL) ACH PMT NO. - 80131817	51.50
CINTAS CORPORATION	LAUNDRY/JANITORIAL SERVICES CREDIT CARD PMT NO. - 70000443	11,824.57
COPIERS NORTHWEST INC	OPERATING RENTALS/LEASES ACH PMT NO. - 80131669	881.77
DEECO INC	EMISSION TESTING ACH PMT NO. - 80131672	94,820.00
ELJAY OIL CO INC	LUBRICANTS CREDIT CARD PMT NO. - 70000430	1,182.21
ELJAY OIL CO INC	MOTOR FUEL-OUTSIDE VENDOR CREDIT CARD PMT NO. - 70000434	2,096.07
FASTENAL CO	OPERATING SUPPLIES ACH PMT NO. - 80131714	777.94
FASTENAL CO	PERSONAL PROTECTIVE EQUIPMENT ACH PMT NO. - 80131714	1,478.98
FASTENAL CO	REPAIR & MAINTENANCE SUPPLIES ACH PMT NO. - 80131714	594.25
FASTENAL CO	SAFETY SUPPLIES ACH PMT NO. - 80131674	47.45
FIRE CONTROL SPRINKLER SYSTEMS COMPANY INC	EQUIPMENT REPAIRS/MAINTENANCE ACH PMT NO. - 80131676	2,538.00

HONORABLE MAYOR
AND COUNCIL MEMBERS

07/29/24
PAGE 22

PROCESSING OF VOUCHERS RESULTS IN CLAIMS AS FOLLOWS:

GENERAL KINEMATICS CORPORATION	REPAIR & MAINTENANCE SUPPLIES CREDIT CARD PMT NO. - 70000436	3,002.18
GORLEY LOGISTICS LLC dba FIKES NORTHWEST	OPERATING SUPPLIES ACH PMT NO. - 80131675	8.32
ICMA RETIREMENT TRUST 457 % FIRST NATIONAL BANK OF MD	DEFERRED COMPENSATION-MATCHING CHECK NO. - 00604593	3,920.00

KNIGHT CONSTRUCTION & SUPPLY INC	EQUIPMENT REPAIRS/MAINTENANCE ACH PMT NO. - 80131684	440,442.98
MCKINSTRY CO LLC LOCKBOX	EQUIPMENT REPAIRS/MAINTENANCE ACH PMT NO. - 80131685	3,878.85
NORCO INC	CHEMICAL/LAB SUPPLIES CREDIT CARD PMT NO. - 70000438	1,821.84
NORTHSTAR CHEMICAL INC	CHEMICAL/LAB SUPPLIES ACH PMT NO. - 80131724	3,748.20
OIL RE-REFINING CO INC	HAZARDOUS WASTE DISPOSAL ACH PMT NO. - 80131687	778.75
ORKIN	PROFESSIONAL SERVICES CHECK NO. - 00604458	201.64
OVERHEAD DOOR CORPORATION DBA WAYNE DALTON SALES &	BUILDING REPAIRS/MAINTENANCE CHECK NO. - 00604586	277.95
OXARC INC	CHEMICAL/LAB SUPPLIES CREDIT CARD PMT NO. - 70000432	4,590.97
PETE LIEN & SONS INC	CHEMICAL/LAB SUPPLIES ACH PMT NO. - 80131808	45,383.11
SPECIALTY MACHINING & MFG CO	REPAIR & MAINTENANCE SUPPLIES ACH PMT NO. - 80131691	686.70
SPOKANE INT'L AIRPORT	OPERATING RENTALS/LEASES ACH PMT NO. - 80131693	66,585.60
UNITED RENTALS NW INC	OPERATING RENTALS/LEASES CHECK NO. - 00604460	3,675.48
US BANK TREASURY MANAGEMENT SERVICES	BANK FEES CHECK NO. - 00604503	269.25
US BANK OR CITY TREASURER EMP BENEFITS (CITY)	SOCIAL SECURITY CHECK NO. - 00604603	23,342.60
US BANK TRUST NA OR CITY OF SPOKANE	RETIREMENT ACH PMT NO. - 80131861	31,758.59
WA STATE DEPT OF ECOLOGY	PERMITS/OTHER FEES ACH PMT NO. - 80131816	2,635.00
WASHINGTON EQUIPMENT MANUFACTURING CO INC	EQUIPMENT REPAIRS/MAINTENANCE ACH PMT NO. - 80131697	50,659.23

HONORABLE MAYOR
AND COUNCIL MEMBERS

07/29/24
PAGE 23

PROCESSING OF VOUCHERS RESULTS IN CLAIMS AS FOLLOWS:

TOTAL FOR 4490 - SOLID WASTE DISPOSAL	-----	1,075,492.34
---------------------------------------	-------	--------------

4500 - SOLID WASTE COLLECTION

ALEX LYNCH	PERMITS/OTHER FEES CHECK NO. - 00604578	301.00
ALSCO DIVISION OF ALSCO INC	LAUNDRY/JANITORIAL SERVICES ACH PMT NO. - 80131768	4,858.98
AVISTA UTILITIES	UTILITY LIGHT/POWER SERVICE	

	ACH PMT NO. - 80131662	8,448.23
AVISTA UTILITIES	UTILITY NATURAL GAS ACH PMT NO. - 80131662	574.15
BIG BELLY SOLAR LLC	OPERATING RENTALS/LEASES CREDIT CARD PMT NO. - 70000429	6,734.70
C & C YARD CARE	LANDSCAPE/GROUNDS MAINT ACH PMT NO. - 80131664	2,245.53
CASCADE ENGINEERING INC	MINOR EQUIPMENT CHECK NO. - 00604563	125,694.44
CENTURYLINK	TELEPHONE CHECK NO. - 00604564	409.39
CINTAS CORPORATION NO 2	OPERATING SUPPLIES ACH PMT NO. - 80131775	162.17
COMCAST	TELEPHONE CHECK NO. - 00604495	174.24
CONTRACT DESIGN ASSOCIATES INC	CONTRACTUAL SERVICES ACH PMT NO. - 80131779	5,369.34
CONTRACT DESIGN ASSOCIATES INC	MINOR EQUIPMENT ACH PMT NO. - 80131779	600.98
CONTRACT DESIGN ASSOCIATES INC	OFFICE FURNITURE (NON CAPITAL) ACH PMT NO. - 80131779	2,512.81
COPIERS NORTHWEST INC	OFFICE SUPPLIES ACH PMT NO. - 80131780	94.42
COPIERS NORTHWEST INC	OPERATING RENTALS/LEASES ACH PMT NO. - 80131669	1,344.38
COWLES PUBLISHING COMPANY dba SPOKESMAN-REVIEW	PUBLICATIONS ACH PMT NO. - 80131671	520.00
FASTENAL CO	OPERATING SUPPLIES ACH PMT NO. - 80131788	1,661.45
GORLEY LOGISTICS LLC dba FIKES NORTHWEST	OPERATING SUPPLIES ACH PMT NO. - 80131790	83.17

HONORABLE MAYOR
AND COUNCIL MEMBERS

07/29/24
PAGE 24

PROCESSING OF VOUCHERS RESULTS IN CLAIMS AS FOLLOWS:

ICMA RETIREMENT TRUST 457 % FIRST NATIONAL BANK OF MD	DEFERRED COMPENSATION-MATCHING CHECK NO. - 00604593	4,810.00
JACOB GREENWOOD	PERMITS/OTHER FEES CHECK NO. - 00604566	338.00
LINN MACHINE & MFG	EQUIPMENT REPAIRS/MAINTENANCE ACH PMT NO. - 80131801	2,700.55
MORGAN SEVERNS	PERMITS/OTHER FEES CHECK NO. - 00604459	136.00
SKYLER COVER	PERMITS/OTHER FEES CHECK NO. - 00604565	392.00
SOLID WASTE MANAGEMENT IMPREST CASH FUND	PARKING/TOLLS (LOCAL) CHECK NO. - 00604580	9.00

SPOKANE COUNTY TREASURER	UTIL GARBAGE/WASTE REMOVAL ACH PMT NO. - 80131811	172,610.73
SPOKANE PRO CARE INC	CONTRACTUAL SERVICES ACH PMT NO. - 80131694	893.80
SWANA	OTH DUES/SUBSCRIPTNS/MEMBERSHP CHECK NO. - 00604583	1,580.00
US BANK OR CITY TREASURER EMP BENEFITS (CITY)	SOCIAL SECURITY CHECK NO. - 00604603	25,716.40
US BANK TRUST NA OR CITY OF SPOKANE	RETIREMENT ACH PMT NO. - 80131861	37,753.69
VERIZON WIRELESS	CELL PHONE ACH PMT NO. - 80131696	670.19
WASTEQUIP WASHINGTON	OPERATING SUPPLIES CHECK NO. - 00604464	700.88
TOTAL FOR 4500 - SOLID WASTE COLLECTION		410,100.62

4530 - SOLID WASTE LANDFILLS

AVISTA UTILITIES	UTILITY LIGHT/POWER SERVICE ACH PMT NO. - 80131771	1,235.91
TOTAL FOR 4530 - SOLID WASTE LANDFILLS		1,235.91

4600 - GOLF FUND

ICMA RETIREMENT TRUST 457 % FIRST NATIONAL BANK OF MD	DEFERRED COMPENSATION-MATCHING CHECK NO. - 00604593	761.00
US BANK TREASURY MANAGEMENT SERVICES	BANK FEES CHECK NO. - 00604503	524.05

HONORABLE MAYOR
AND COUNCIL MEMBERS

07/29/24
PAGE 25

PROCESSING OF VOUCHERS RESULTS IN CLAIMS AS FOLLOWS:

US BANK OR CITY TREASURER EMP BENEFITS (CITY)	SOCIAL SECURITY CHECK NO. - 00604603	6,830.88
US BANK TRUST NA OR CITY OF SPOKANE	RETIREMENT ACH PMT NO. - 80131861	5,433.16
TOTAL FOR 4600 - GOLF FUND		13,549.09

4700 - DEVELOPMENT SVCS CENTER

COPIERS NORTHWEST INC	OPERATING RENTALS/LEASES ACH PMT NO. - 80131669	357.14
ICMA RETIREMENT TRUST 457 % FIRST NATIONAL BANK OF MD	DEFERRED COMPENSATION-MATCHING CHECK NO. - 00604593	2,919.38
MOON SECURITY SERVICES INC PO DRAWER B	PERMIT REFUNDS PAYABLE CHECK NO. - 00604455	20.00

RIGHT NOW HEATING AND COOLING 212 EVANS ST	PERMIT REFUNDS PAYABLE CHECK NO. - 00604457	65.00
SPOKANE NEIGHBORHOOD ACTION PARTNERS	PERMIT REFUNDS PAYABLE CHECK NO. - 00604577	20.00
STURM HEATING INC 1112 N NELSON ST	PERMIT REFUNDS PAYABLE CHECK NO. - 00604576	30.00
US BANK TREASURY MANAGEMENT SERVICES	BANK FEES CHECK NO. - 00604503	190.76
US BANK OR CITY TREASURER EMP BENEFITS (CITY)	SOCIAL SECURITY CHECK NO. - 00604603	15,200.18
US BANK TRUST NA OR CITY OF SPOKANE	RETIREMENT ACH PMT NO. - 80131861	21,902.11
TOTAL FOR 4700 - DEVELOPMENT SVCS CENTER		40,704.57

5100 - FLEET SERVICES FUND

ALASKA RUBBER GROUP INC DBA ARG INDUSTRIAL	VEHICLE REPAIR & MAINT SUPPLY CREDIT CARD PMT NO. - 70000442	189.32
AMERICAN RADIATOR INC	EQUIPMENT REPAIRS/MAINTENANCE ACH PMT NO. - 80131770	156.34
EVERGREEN STATE TOWING LLC DBA SPOKANE VALLEY TOWING	TOWING EXPENSE CREDIT CARD PMT NO. - 70000445	1,399.56
GRAINGER INC	VEHICLE REPAIR & MAINT SUPPLY ACH PMT NO. - 80131792	1,650.01
HOME DEPOT USA INC HOME DEPOT PRO	OFFICE SUPPLIES ACH PMT NO. - 80131795	57.89

HONORABLE MAYOR
AND COUNCIL MEMBERS

07/29/24
PAGE 26

PROCESSING OF VOUCHERS RESULTS IN CLAIMS AS FOLLOWS:

ICMA RETIREMENT TRUST 457 % FIRST NATIONAL BANK OF MD	DEFERRED COMPENSATION-MATCHING CHECK NO. - 00604593	1,760.00
KENWORTH SALES COMPANY	EQUIPMENT REPAIRS/MAINTENANCE ACH PMT NO. - 80131800	19,944.91
PAPE MACHINERY INC	EQUIPMENT REPAIRS/MAINTENANCE ACH PMT NO. - 80131807	17,750.73
PAPE MACHINERY INC	OPERATING RENTALS/LEASES ACH PMT NO. - 80131807	9,810.00
POMP'S TIRE SERVICE INC	VEHICLE REPAIR & MAINT SUPPLY ACH PMT NO. - 80131809	29,024.05
SAFETY KLEEN CORPORATION	HAZARDOUS WASTE DISPOSAL CHECK NO. - 00604579	179.50
US BANK OR CITY TREASURER EMP BENEFITS (CITY)	SOCIAL SECURITY CHECK NO. - 00604603	9,786.53
US BANK TRUST NA OR CITY OF SPOKANE	RETIREMENT ACH PMT NO. - 80131861	14,330.21
WA STATE DEPT OF REVENUE	DEPOSIT-SALES TAX	

OR CITY OF SPOKANE	CHECK NO. - 00604463	134.01
WA STATE DEPT OF REVENUE OR CITY OF SPOKANE	WA DEPT OF REVENUE CHECK NO. - 00604463	0.01
TOTAL FOR 5100 - FLEET SERVICES FUND		----- 106,173.07

5200 - PUBLIC WORKS AND UTILITIES

ALLIED ENVELOPE	OPERATING SUPPLIES ACH PMT NO. - 80131767	43,621.80
CONTRACT DESIGN ASSOCIATES INC	CONTRACTUAL SERVICES ACH PMT NO. - 80131779	5,369.34
CONTRACT DESIGN ASSOCIATES INC	MINOR EQUIPMENT ACH PMT NO. - 80131779	1,201.85
CONTRACT DESIGN ASSOCIATES INC	OFFICE FURNITURE (NON CAPITAL) ACH PMT NO. - 80131779	3,536.58
COPIERS NORTHWEST INC	OPERATING RENTALS/LEASES ACH PMT NO. - 80131669	123.36
ICMA RETIREMENT TRUST 457 % FIRST NATIONAL BANK OF MD	DEFERRED COMPENSATION-MATCHING CHECK NO. - 00604593	920.00
SPOKANE COUNTY TREASURER	SPOKANE COUNTY ACH PMT NO. - 80131692	2,421.18
US BANK TREASURY MANAGEMENT SERVICES	BANK FEES CHECK NO. - 00604503	19,823.19

HONORABLE MAYOR
AND COUNCIL MEMBERS

07/29/24
PAGE 27

PROCESSING OF VOUCHERS RESULTS IN CLAIMS AS FOLLOWS:

US BANK OR CITY TREASURER EMP BENEFITS (CITY)	SOCIAL SECURITY CHECK NO. - 00604603	4,296.56
US BANK TRUST NA OR CITY OF SPOKANE	RETIREMENT ACH PMT NO. - 80131861	6,385.22
TOTAL FOR 5200 - PUBLIC WORKS AND UTILITIES		----- 87,699.08

5300 - IT FUND

ICMA RETIREMENT TRUST 457 % FIRST NATIONAL BANK OF MD	DEFERRED COMPENSATION-MATCHING CHECK NO. - 00604593	2,196.00
NETWORK DESIGN & MGMNT INC DBA NDM TECHNOLOGIES	SOFTWARE MAINTENANCE ACH PMT NO. - 80131838	28,630.04
RIVER PARK SQUARE LLC	PARKING/TOLLS (LOCAL) ACH PMT NO. - 80131810	1,000.00
US BANK OR CITY TREASURER EMP BENEFITS (CITY)	SOCIAL SECURITY CHECK NO. - 00604603	14,668.02
US BANK TRUST NA OR CITY OF SPOKANE	RETIREMENT ACH PMT NO. - 80131861	21,306.40
US POSTMASTER	PREPAID POSTAGE CHECK NO. - 00604462	50,000.00

TOTAL FOR 5300 - IT FUND 117,800.46

5310 - IT CAPITAL REPLACEMENT FUND

COMPUNET INC COMPUTER/MICRO EQUIPMENT
LB 410802 ACH PMT NO. - 80131668 168,449.69

DELL MARKETING LP COMPUTERS
%DELL USA LP ACH PMT NO. - 80131784 2,747.46

TOTAL FOR 5310 - IT CAPITAL REPLACEMENT FUND 171,197.15

5400 - REPROGRAPHICS FUND

ED HAIGHT SERVICE EQUIPMENT REPAIRS/MAINTENANCE
ACH PMT NO. - 80131818 209.83

ICMA RETIREMENT TRUST 457 DEFERRED COMPENSATION-MATCHING
% FIRST NATIONAL BANK OF MD CHECK NO. - 00604593 60.00

US BANK OR CITY TREASURER SOCIAL SECURITY
EMP BENEFITS (CITY) CHECK NO. - 00604603 376.77

US BANK TRUST NA RETIREMENT
OR CITY OF SPOKANE ACH PMT NO. - 80131861 570.95

HONORABLE MAYOR 07/29/24
AND COUNCIL MEMBERS PAGE 28

PROCESSING OF VOUCHERS RESULTS IN CLAIMS AS FOLLOWS:

TOTAL FOR 5400 - REPROGRAPHICS FUND 1,217.55

5500 - PURCHASING & STORES FUND

ICMA RETIREMENT TRUST 457 DEFERRED COMPENSATION-MATCHING
% FIRST NATIONAL BANK OF MD CHECK NO. - 00604593 550.00

US BANK OR CITY TREASURER SOCIAL SECURITY
EMP BENEFITS (CITY) CHECK NO. - 00604603 2,176.59

US BANK TRUST NA RETIREMENT
OR CITY OF SPOKANE ACH PMT NO. - 80131861 3,126.28

VERIZON WIRELESS CELL PHONE
ACH PMT NO. - 80131814 85.52

TOTAL FOR 5500 - PURCHASING & STORES FUND 5,938.39

5600 - ACCOUNTING SERVICES

DELL MARKETING LP MINOR EQUIPMENT
%DELL USA LP ACH PMT NO. - 80131709 286.16

ICMA RETIREMENT TRUST 457 DEFERRED COMPENSATION-MATCHING
% FIRST NATIONAL BANK OF MD CHECK NO. - 00604593 2,346.24

US BANK OR CITY TREASURER SOCIAL SECURITY
EMP BENEFITS (CITY) CHECK NO. - 00604603 10,093.62

US BANK TRUST NA	RETIREMENT	
OR CITY OF SPOKANE	ACH PMT NO. - 80131861	14,652.38

TOTAL FOR 5600 - ACCOUNTING SERVICES		27,378.40
--------------------------------------	--	-----------

5700 - MY SPOKANE

COMPUNET INC	SUBSCRIPTION BASED IT ARNGMTS	
LB 410802	ACH PMT NO. - 80131668	3,837.82

CONTRACT DESIGN ASSOCIATES INC	OTHER MISC CHARGES	
	ACH PMT NO. - 80131779	5,088.12

ICMA RETIREMENT TRUST 457	DEFERRED COMPENSATION-MATCHING	
% FIRST NATIONAL BANK OF MD	CHECK NO. - 00604593	610.00

US BANK OR CITY TREASURER	SOCIAL SECURITY	
EMP BENEFITS (CITY)	CHECK NO. - 00604603	2,804.91

US BANK TRUST NA	RETIREMENT	
OR CITY OF SPOKANE	ACH PMT NO. - 80131861	4,077.10

TOTAL FOR 5700 - MY SPOKANE		16,417.95
-----------------------------	--	-----------

HONORABLE MAYOR
AND COUNCIL MEMBERS

07/29/24
PAGE 29

PROCESSING OF VOUCHERS RESULTS IN CLAIMS AS FOLLOWS:

5750 - OFFICE OF PERFORMANCE MGMT

ICMA RETIREMENT TRUST 457	DEFERRED COMPENSATION-MATCHING	
% FIRST NATIONAL BANK OF MD	CHECK NO. - 00604593	450.00

US BANK OR CITY TREASURER	SOCIAL SECURITY	
EMP BENEFITS (CITY)	CHECK NO. - 00604603	2,160.38

US BANK TRUST NA	RETIREMENT	
OR CITY OF SPOKANE	ACH PMT NO. - 80131861	2,775.52

VERIZON WIRELESS	CELL PHONE	
	ACH PMT NO. - 80131814	262.08

TOTAL FOR 5750 - OFFICE OF PERFORMANCE MGMT		5,647.98
---	--	----------

5800 - RISK MANAGEMENT FUND

ICMA RETIREMENT TRUST 457	DEFERRED COMPENSATION-MATCHING	
% FIRST NATIONAL BANK OF MD	CHECK NO. - 00604593	150.00

US BANK	BANK FEES	
TREASURY MANAGEMENT SERVICES	CHECK NO. - 00604503	220.22

US BANK	EARNINGS CREDIT	
TREASURY MANAGEMENT SERVICES	CHECK NO. - 00604503	220.22-

US BANK OR CITY TREASURER	INSURANCE CLAIMS	
LIABILITY CLAIMS	ACH PMT NO. - 80131757	12,962.68

US BANK OR CITY TREASURER	SOCIAL SECURITY	
EMP BENEFITS (CITY)	CHECK NO. - 00604603	1,091.61

US BANK TRUST NA	RETIREMENT	
OR CITY OF SPOKANE	ACH PMT NO. - 80131861	1,577.67

TOTAL FOR 5800 - RISK MANAGEMENT FUND 15,781.96

5810 - WORKERS' COMPENSATION FUND

ICMA RETIREMENT TRUST 457 DEFERRED COMPENSATION-MATCHING
% FIRST NATIONAL BANK OF MD CHECK NO. - 00604593 210.00
US BANK OR CITY TREASURER SOCIAL SECURITY
EMP BENEFITS (CITY) CHECK NO. - 00604603 758.94
US BANK TRUST NA RETIREMENT
OR CITY OF SPOKANE ACH PMT NO. - 80131861 1,075.10

TOTAL FOR 5810 - WORKERS' COMPENSATION FUND 2,044.04

5820 - UNEMPLOYMENT COMPENSATION FUND

HONORABLE MAYOR 07/29/24
AND COUNCIL MEMBERS PAGE 30

PROCESSING OF VOUCHERS RESULTS IN CLAIMS AS FOLLOWS:

ICMA RETIREMENT TRUST 457 DEFERRED COMPENSATION-MATCHING
% FIRST NATIONAL BANK OF MD CHECK NO. - 00604593 3.75
US BANK OR CITY TREASURER SOCIAL SECURITY
EMP BENEFITS (CITY) CHECK NO. - 00604603 17.71
US BANK TRUST NA RETIREMENT
OR CITY OF SPOKANE ACH PMT NO. - 80131861 25.04
WA STATE EMPLOYMENT SECURITY DEPOSIT LONG TERM CARE TAX
WA CARES FUND CHECK NO. - 00604487 268,373.71
WA STATE EMPLOYMENT SECURITY DEPOSIT-PD FAMILY MEDICAL LEAV
PAID FAMILY MEDICAL LEAVE CHECK NO. - 00604486 498,489.33

TOTAL FOR 5820 - UNEMPLOYMENT COMPENSATION FUND 766,909.54

5830 - EMPLOYEES BENEFITS FUND

ALLIANT INSURANCE SERVICES INC CONTRACTUAL SERVICES
ACH PMT NO. - 80131766 5,720.00
DEER OAKS EAP SERVICES LLC PROFESSIONAL SERVICES
ACH PMT NO. - 80131783 4,972.00
DELTA DENTAL OF WASHINGTON INSURANCE ADMINISTRATION
ACH PMT NO. - 80131828 14,787.45
DELTA DENTAL OF WASHINGTON INSURANCE CLAIMS
ACH PMT NO. - 80131828 36,038.79
HRA VEBA TRUST INSURANCE PREMIUMS
HRA VEBA TRUST CONTRIBUTIONS ACH PMT NO. - 80131833 59,371.50
ICMA RETIREMENT TRUST 457 DEFERRED COMPENSATION-MATCHING
% FIRST NATIONAL BANK OF MD CHECK NO. - 00604593 150.00
KAISER FOUNDATION HEALTH PLAN INSURANCE ADMINISTRATION
OF WASHINGTON ACH PMT NO. - 80131748 87,283.97

KAISER FOUNDATION HEALTH PLAN OF WASHINGTON	INSURANCE CLAIMS ACH PMT NO. - 80131834	195,035.02
KAISER FOUNDATION HEALTH PLAN OF WASHINGTON	INSURANCE PREMIUMS ACH PMT NO. - 80131748	25,348.62
PREMERA BLUE CROSS	INSURANCE ADMINISTRATION ACH PMT NO. - 80131843	61,958.56
PREMERA BLUE CROSS OR SPOKANE CITY TREASURER	INSURANCE CLAIMS ACH PMT NO. - 80131751	296,044.21
SPOKANE FIRE FIGHTERS BENEFIT TRUST	INSURANCE PREMIUMS ACH PMT NO. - 80131853	816,420.00
US BANK OR CITY TREASURER EMP BENEFITS (CITY)	SOCIAL SECURITY CHECK NO. - 00604603	710.62

HONORABLE MAYOR
AND COUNCIL MEMBERS

07/29/24
PAGE 31

PROCESSING OF VOUCHERS RESULTS IN CLAIMS AS FOLLOWS:

US BANK TRUST NA OR CITY OF SPOKANE	RETIREMENT ACH PMT NO. - 80131861	986.42
TOTAL FOR 5830 - EMPLOYEES BENEFITS FUND		----- 1,604,827.16

5900 - FACILITIES MANAGEMENT FUND OPS

ABM JANITORIAL SERVICES SOUTH SOUTH CENTRAL INC dba	CONTRACTUAL SERVICES ACH PMT NO. - 80131700	4,403.70
AM HARDWARE CO	BUILDING REPAIRS/MAINTENANCE ACH PMT NO. - 80131769	281.00
AM HARDWARE CO	REPAIR & MAINTENANCE SUPPLIES ACH PMT NO. - 80131702	588.16
AVISTA CORPORATION	UTILITY LIGHT/POWER SERVICE ACH PMT NO. - 80131703	21,857.82
AVISTA CORPORATION	UTILITY NATURAL GAS ACH PMT NO. - 80131703	278.43
CAMTEK INC	BUILDING REPAIRS/MAINTENANCE ACH PMT NO. - 80131705	1,635.00
CAMTEK INC	REPAIR & MAINTENANCE SUPPLIES ACH PMT NO. - 80131665	725.57
ICMA RETIREMENT TRUST 457 % FIRST NATIONAL BANK OF MD	DEFERRED COMPENSATION-MATCHING CHECK NO. - 00604593	592.50
NW MUSEUM OF ARTS & CULTURE/ DIV OF EASTERN WA STATE	OPERATING RENTALS/LEASES ACH PMT NO. - 80131805	604.95
ORKIN	BUILDING REPAIRS/MAINTENANCE CHECK NO. - 00604480	1,329.75
ROAR WORKS LLC	LANDSCAPE/GROUNDS MAINT ACH PMT NO. - 80131727	17,276.50
TK ELEVATOR CORPORATION	BUILDING REPAIRS/MAINTENANCE CHECK NO. - 00604502	1,205.54

US BANK OR CITY TREASURER EMP BENEFITS (CITY)	SOCIAL SECURITY CHECK NO. - 00604603	3,378.68
US BANK TRUST NA OR CITY OF SPOKANE	RETIREMENT ACH PMT NO. - 80131861	4,936.50
VERIZON WIRELESS	CELL PHONE ACH PMT NO. - 80131730	721.14
VERTICAL OPTIONS LLC	BUILDING REPAIRS/MAINTENANCE ACH PMT NO. - 80131731	4,231.38
WAXIE SANITARY SUPPLY	OPERATING SUPPLIES CHECK NO. - 00604585	4,312.70

HONORABLE MAYOR
AND COUNCIL MEMBERS

07/29/24
PAGE 32

PROCESSING OF VOUCHERS RESULTS IN CLAIMS AS FOLLOWS:

TOTAL FOR 5900 - FACILITIES MANAGEMENT FUND OPS		68,359.32

5902 - PROPERTY ACQUISITION POLICE		

CLARY LONGVIEW LLC DBA BUD CLARY FORD/HYUNDAI	VEHICLES ACH PMT NO. - 80131667	346,954.79
TOTAL FOR 5902 - PROPERTY ACQUISITION POLICE		346,954.79

6100 - RETIREMENT		

ICMA RETIREMENT TRUST 457 % FIRST NATIONAL BANK OF MD	DEFERRED COMPENSATION-MATCHING CHECK NO. - 00604593	220.00
US BANK OR CITY TREASURER EMP BENEFITS (CITY)	SOCIAL SECURITY CHECK NO. - 00604603	773.34
US BANK TRUST NA OR CITY OF SPOKANE	RETIREMENT ACH PMT NO. - 80131861	1,109.58
TOTAL FOR 6100 - RETIREMENT		2,102.92

6200 - FIREFIGHTERS' PENSION FUND		

ALLIANT INSURANCE SERVICES INC	INSURANCE ADMINISTRATION ACH PMT NO. - 80131766	1,665.00
DELTA DENTAL OF WASHINGTON	INSURANCE ADMINISTRATION ACH PMT NO. - 80131828	1,105.15
DELTA DENTAL OF WASHINGTON	SERVICE REIMBURSEMENT ACH PMT NO. - 80131828	1,197.00
MARTIN PITTMAN	SERVICE REIMBURSEMENT CHECK NO. - 00604598	165.00
PREMERA BLUE CROSS	INSURANCE ADMINISTRATION ACH PMT NO. - 80131843	6,801.40
PREMERA BLUE CROSS OR SPOKANE CITY TREASURER	SERVICE REIMBURSEMENT ACH PMT NO. - 80131751	3,765.57
SNOW PEAK 1 LIBERTY LAKE REAL	SERVICE REIMBURSEMENT	

ESTATE LLC	CHECK NO. - 00604600	4,475.00
SNOW PEAK 1 LIBERTY LAKE REAL ESTATE LLC	SERVICE REIMBURSEMENT CHECK NO. - 00604600	2,850.00
WELLTOWER PEGASUS TENNANT LLC dba SOUTH HILL VILLAGE	SERVICE REIMBURSEMENT CHECK NO. - 00604608	5,762.00
WELLTOWER PEGASUS TENNANT LLC dba SOUTH HILL VILLAGE	SERVICE REIMBURSEMENT CHECK NO. - 00604608	1,875.00

HONORABLE MAYOR
AND COUNCIL MEMBERS

07/29/24
PAGE 33

PROCESSING OF VOUCHERS RESULTS IN CLAIMS AS FOLLOWS:

TOTAL FOR 6200 - FIREFIGHTERS' PENSION FUND	-----	29,661.12
---	-------	-----------

6255 - LAW ENFORCEMENT RECORDS MGMT

WA STATE DEPT OF LICENSING	DEPOSIT-POLICE GUN PERMITS CHECK NO. - 00604485	18,966.00
WA STATE PATROL	DEPOSIT-SPD STATE REMITTANCE CHECK NO. - 00604488	5,123.50

TOTAL FOR 6255 - LAW ENFORCEMENT RECORDS MGMT	-----	24,089.50
---	-------	-----------

6300 - POLICE PENSION

ALLIANT INSURANCE SERVICES INC	INSURANCE ADMINISTRATION ACH PMT NO. - 80131766	1,665.00
DELTA DENTAL OF WASHINGTON	INSURANCE ADMINISTRATION ACH PMT NO. - 80131828	819.95
DELTA DENTAL OF WASHINGTON	SERVICE REIMBURSEMENT ACH PMT NO. - 80131828	943.00
PREMERA BLUE CROSS	INSURANCE ADMINISTRATION ACH PMT NO. - 80131843	5,002.32
PREMERA BLUE CROSS OR SPOKANE CITY TREASURER	SERVICE REIMBURSEMENT ACH PMT NO. - 80131751	5,255.72

TOTAL FOR 6300 - POLICE PENSION	-----	13,685.99
---------------------------------	-------	-----------

6960 - SALARY CLEARING FUND NEW

AFLAC/AMERICAN FAMILY LIFE ASSURANCE CO OF COLUMBUS	AFLAC ACH PMT NO. - 80131820	15,163.80
CHILD SUPPORT SERVICES IDAHO CHILD SUPPORT RECEIPTING	IDAHO CHILD SUPPORT SERVICE CHECK NO. - 00604591	1,352.88
DIGNITARY PROTECTION TEAM FUND % SPOKANE LAW ENFORCEMENT C U	DIGNITARY PROTECTION TEAM FUND ACH PMT NO. - 80131830	260.00
EDU MEMBERSHIP FUND % SPOKANE LAW ENFORCEMENT C U	EDU MEMBERSHIP FUND ACH PMT NO. - 80131831	15.00
HUMAN RESOURCES RE: PARKING FEES	HUMAN RESOURCES CHECK NO. - 00604592	930.50

ICMA RETIREMENT TRUST 457 % FIRST NATIONAL BANK OF MD	ICMA RETIREMENT TRUST 457D CHECK NO. - 00604593	303,316.75
ICMA RETIREMENT TRUST 457 % FIRST NATIONAL BANK OF MD	ICMA ROTH IRA CHECK NO. - 00604593	34,044.56

HONORABLE MAYOR
AND COUNCIL MEMBERS

07/29/24
PAGE 34

PROCESSING OF VOUCHERS RESULTS IN CLAIMS AS FOLLOWS:

ICMA RETIREMENT TRUST 457 LOAN PAYMENT	ICMA RETR 457D LOAN PAYMENT CHECK NO. - 00604594	57,044.61
ING LIFE INSURANCE & ANNUITY OR CITY OF SPOKANE TREASURER	ICMA ROTH IRA CHECK NO. - 00604595	6,496.55
ING LIFE INSURANCE & ANNUITY OR CITY OF SPOKANE TREASURER	ING LIFE INSURANCE&ANNUITY CO CHECK NO. - 00604595	93,087.25
LT & CAPT ASSOCIATION - LTD	LTD - LTS & CAPTS ACH PMT NO. - 80131835	747.50
LTS & CPTS LEGAL DEFENSE FUND	LEGAL DEFENSE LTS&CAPTS ACH PMT NO. - 80131836	46.00
M & P ASSOCIATION	M&P ASSOCIATION ACH PMT NO. - 80131837	3,480.54
PEOPLE QUALIFIED COMMITTEE AFL-CIO	PEOPLE QUALIFIED COMMITTEE CHECK NO. - 00604597	5.00
POLICE GUILD LEGAL DEFENSE FUND	POLICE GUILD LEGAL DEFENSE ACH PMT NO. - 80131832	634.00
PRE-PAID LEGAL SERVICES INC LEGALSHIELD	PRE-PAID LEGAL SERVICE INC CHECK NO. - 00604599	333.23
REHN & ASSOCIATES SPOKANE CITY TREASURER	AW REHN-SEC 125 DEPENDENT CARE ACH PMT NO. - 80131845	5,631.95
REHN & ASSOCIATES SPOKANE CITY TREASURER	AW REHN-SEC 125 HEALTH ACH PMT NO. - 80131845	19,039.20
SPOKANE FIRE FIGHTERS BENEFIT TRUST	BENEFIT SOLUTIONS INC EE ACH PMT NO. - 80131851	67,254.40
SPOKANE FIRE FIGHTERS BENEFIT TRUST	BENEFIT SOLUTIONS MEDSFO EE ACH PMT NO. - 80131851	2,686.00
SPOKANE FIRE FIGHTERS BENEFIT TRUST	FIRE BENEFIT TRUST-VOL LIFE ACH PMT NO. - 80131852	817.80
SPOKANE FIRE FIGHTERS BENEFIT TRUST	MEDFCH (EE) ACH PMT NO. - 80131851	894.14
SPOKANE POLICE BENEFIT ASSOC % SPOKANE LAW ENFORCEMENT C U	SPOKANE POLICE BENEFIT ASSOC ACH PMT NO. - 80131847	487.50
SPOKANE POLICE CHAPLAIN ASSOCIATION	POLICE CHAPLIN ASSOC ACH PMT NO. - 80131848	3,565.00
SPOKANE POLICE GUILD FRATERNAL ORDER OF POLICE	POLICE GUILD FRAT ORDER OF POL ACH PMT NO. - 80131854	838.17
SPOKANE POLICE GUILD LONG TERM DISABILITY	POLICE GUILD LTD ACH PMT NO. - 80131850	20,670.00

SPOKANE POLICE K-9 MEMBERSHIP FUND	POLICE K9 MEMBERSHIP FUND ACH PMT NO. - 80131849	75.00
------------------------------------	---	-------

HONORABLE MAYOR
AND COUNCIL MEMBERS

07/29/24
PAGE 35

PROCESSING OF VOUCHERS RESULTS IN CLAIMS AS FOLLOWS:

SPOKANE POLICE SWAT TEAM %SPOKANE LAW ENFORCEMENT C U	SPOKANE POLICE SWAT TEAM ACH PMT NO. - 80131857	420.00
SPOKANE POLICE TACTICAL TEAM % SPOKANE LAW ENFORCEMENT C U	SPOKANE POLICE TACTICAL TEAM ACH PMT NO. - 80131859	608.00
STANDARD INSURANCE COMPANY	STANDARD INSURANCE CO (VL/E) ACH PMT NO. - 80131856	10,951.90
STANDARD INSURANCE COMPANY	STANDARD LIFE INS-VL/D CHILD ACH PMT NO. - 80131856	188.00
STANDARD INSURANCE COMPANY	STANDARD LIFE INS-VL/D SPOUSE ACH PMT NO. - 80131856	2,322.30
STATE DISBURSMENT UNIT ATTN: EMPLOYER PAYMENTS	STATE DISBURSEMENT UNIT CHECK NO. - 00604601	862.58
UNITED STATES TREASURY INTERNAL REVENUE SERVICE/ ACS	UNITED STATES TREASURY CHECK NO. - 00604602	12.50
US BANK OR CITY TREASURER EMP BENEFITS (CITY)	FICA WITHHOLDING-CITY CHECK NO. - 00604603	354,559.26
US BANK OR CITY TREASURER EMP BENEFITS (CITY)	FIT WITHHOLDING-CITY CHECK NO. - 00604603	941,452.01
US BANK OR CITY TREASURER EMP BENEFITS (CITY)	MEDI WITHHOLDING-CITY CHECK NO. - 00604603	139,875.43
US BANK TRUST NA OR CITY OF SPOKANE	CITY RETIREMENT SYSTEM ACH PMT NO. - 80131861	583,069.07
VOYA FINANCIAL LOAN REPAYMENT	VOYA LOANS CHECK NO. - 00604604	2,779.53
WA GET PROGRAM	WA GET PROGRAM CHECK NO. - 00604605	375.00
WA ST COUNCIL OF CITY & COUNTY EMPLOYEES	WA ST COUNCIL OF CITY&CO EMPL ACH PMT NO. - 80131863	31,941.20
WA STATE SUPPORT REGISTRY OR CITY OF SPOKANE TREASURER	WA STATE CHILD SUPPORT CHECK NO. - 00604606	15,965.52
WASHINGTON LEOFF DEPT OF RETIREMENT SYSTEMS	DEPT OF RET SYS-LEOFF 2 CHECK NO. - 00604607	701,481.86
WESTERN STATES POLICE MEDICAL TRUST	NW PUBLIC EMP MEDICAL TRUST CHECK NO. - 00604609	1,012.50
WSCCCE, AFSCME, AFL-CIO	WSCCCE AFSCME AFL CIO ACH PMT NO. - 80131866	319.70

TOTAL FOR 6960 - SALARY CLEARING FUND NEW	-----	3,427,113.69
---	-------	--------------

TOTAL CLAIMS	-----	13,343,133.28
--------------	-------	---------------



Agenda Sheet for City Council:

Committee: Date: N/A

Committee Agenda type:

Council Meeting Date: 08/12/2024

Date Rec'd	8/7/2024
Clerk's File #	CPR 2024-0002
Cross Ref #	
Project #	
Bid #	
Requisition #	

Submitting Dept	ACCOUNTING & GRANTS
Contact Name/Phone	LEONARD 625-6028
Contact E-Mail	LDAVIS@SPOKANECITY.ORG
Agenda Item Type	Claim Item
Council Sponsor(s)	
Agenda Item Name	5600-CLAIMS-2024

Agenda Wording

Report of the Mayor of pending claims & payments of previously approved obligations through: 08/2/2024. Total:\$9,499,707.31 with Parks & Library claims being approved by their respective boards. Claims excluding Parks & Library Total:\$9,082,447.55.

Summary (Background)

Pages 1-36 Check numbers: 604616 - 604778 Credit Card numbers: 000450 - 000482 ACH payment numbers: 131867 - 132104 On file for review in City Clerks Office: 36 Page listing of Claims Note:

Lease? NO Grant related? NO Public Works? NO

Fiscal Impact

Approved in Current Year Budget?

Total Cost	\$
Current Year Cost	\$
Subsequent Year(s) Cost	\$

Narrative

Amount	Budget Account
---------------	-----------------------

Expense \$ \$9,082,447.55	# Various
Select \$	#
Select \$	#
Select \$	#
\$	#
\$	#

REPORT: PG3620
SYSTEM: FMSAP
USER: MANAGER
RUN NO: 31

APPROVAL FUND SUMMARY

DATE: 08/05/24
TIME: 10:48
PAGE: 1

FUND	FUND NAME	AMOUNT
0100	GENERAL FUND	53,123.42
1100	STREET FUND	70,238.14
1200	CODE ENFORCEMENT FUND	802.63
1300	LIBRARY FUND	26,377.39
1360	MISCELLANEOUS GRANTS FUND	4,423.79
1380	TRAFFIC CALMING MEASURES	10,122.88
1400	PARKS AND RECREATION FUND	32,554.67
1425	AMERICAN RESCUE PLAN	80,998.76
1440	FIRE GRANTS MISCELLANEOUS	1,293.69
1460	PARKING METER REVENUE FUND	3,292.92
1500	PATHS AND TRAILS RESERVE FUND	1,220.00
1560	FORFEITURES & CONTRIBUTION FND	18,336.71
1620	PUBLIC SAFETY & JUDICIAL GRANT	52,501.62
1640	COMMUNICATIONS BLDG M&O FUND	1,829.48
1910	CRIMINAL JUSTICE ASSISTANCE FD	5,320.10
1940	CHANNEL FIVE EQUIPMENT RESERVE	1,506.46
1970	FIRE/EMS FUND	82,357.48
3200	ARTERIAL STREET FUND	3,284,241.18
4100	WATER DIVISION	582,870.63
4250	INTEGRATED CAPITAL MANAGEMENT	328,729.27
4300	SEWER FUND	310,521.36
4480	SOLID WASTE FUND	1,407,627.69
4600	GOLF FUND	4,814.85
4700	DEVELOPMENT SVCS CENTER	8,820.82
5100	FLEET SERVICES FUND	16,804.25
5200	PUBLIC WORKS AND UTILITIES	1,430.84
5300	IT FUND	222,267.23
5310	IT CAPITAL REPLACEMENT FUND	78,103.39
5400	REPROGRAPHICS FUND	4,369.39
5600	ACCOUNTING SERVICES	1,596.21
5700	MY SPOKANE	155.48
5750	OFFICE OF PERFORMANCE MGMT	23,141.30
5800	RISK MANAGEMENT FUND	48,692.03
5820	UNEMPLOYMENT COMPENSATION FUND	55,761.93
5830	EMPLOYEES BENEFITS FUND	1,015,206.11
5900	FACILITIES MANAGEMENT FUND OPS	66,511.21
5902	PROPERTY ACQUISITION POLICE	284,967.99
5903	PROPERTY ACQUISITION FIRE	12,683.45
6060	EMPLOYEES' RETIREMENT FUND	166.54
6070	FIREFIGHTERS' PENSION FUND	96,657.81
6080	POLICE PENSION FUND	77,645.08
6255	LAW ENFORCEMENT RECORDS MGMT	5,617.00
	TOTAL:	8,385,703.18

REPORT: PG3630
SYSTEM: FMSAP
USER: MANAGER
RUN NO: 31

DATE: 08/05/24
TIME:
PAGE: 1

HONORABLE MAYOR
AND COUNCIL MEMBERS

08/05/24
PAGE 2

PROCESSING OF VOUCHERS RESULTS IN CLAIMS AS FOLLOWS:

REPORT: PG3640
SYSTEM: FMSAP
USER: MANAGER
RUN NO: 31

CITY OF SPOKANE
COUNCIL CHECK RANGE/TOTAL

DATE: 08/05/24
TIME: 10:49
PAGE: 1

CHECK #	VENDOR	CITY	LIBRARY	PARKS
	USE TAX AMOUNTS	14,356.11		22.50
00604616	DS SERVICES OF AMERICA INC	90.20		
00604617	HERRES BACKFLOW & CONSTRUCTI	750.00		
00604618	KAISER FOUNDATION HEALTH OF	9,606.96		
00604620	CAROL LAMBERT	30.00		
00604621	COOK SECURITY GROUP	30.00		
00604622	NORTHWEST PERMIT INC	65.00		
00604623	UNITED RENTALS NW INC	1,397.38		
00604624	WASTE MANAGEMENT OF WA DBA	319,951.12		
00604625	OVERHEAD DOOR CORPORATION	1,275.85		
00604626	ADAMS TRACTOR CO INC			3.59
00604627	FITZGERALD ENTERPRISES			466.14
00604628	BLUE MOON GARDEN & NURSERY L			400.86
00604629	CENTURYLINK			217.90
00604630	GENERAL STORE INC			160.43
00604631	KHQ INC			1,200.00
00604632	REBECCA VANDERLOUW			200.00
00604633	MICHAEL LIGHT			87.64
00604634	M & L SUPPLY CO INC			33.41
00604635	MASTER GARDENER FOUNDATION			436.00
00604636	NEALTON INC			186.33
00604637	MOJO REPROGRAHICS LLC			203.83
00604638	NORMED			138.87
00604639	CSWW INC			1,211.06
00604640	NW SEED & PET INC			103.50
00604641	O'REILLY AUTOMOTIVE STORES I			94.04
00604642	PARK DEPT IMPREST FUND			101.97
00604643	ORKIN			159.13
00604644	DONALD SEWELL			374.75
00604645	GLENN SMARTT			81.07
00604646	SHAUN SPRINGER			255.00
00604647	SWIRE PACIFIC HOLDINGS, INC			1,751.62
00604648	VERMEER MOUNTAIN WEST INC			923.11
00604649	WALTER E NELSON CO			527.17
00604650	K&M INTERNATIONAL INC			156.96
00604651	SIR SPEEDY PRINTING	1,728.95		
00604652	COMCAST	4,690.76		
00604653	LEVI MILLER	96.75		
00604654	UNITED STATES TREASURY	12,320.69		
00604655	WA STATE DEPT OF NATURAL	33,667.96		
00604656	WM RECYCLE AMERICA LLC	103,489.12		
00604657	CARRIER CORPORATION		657.16	
00604658	HUB INTERNATIONAL NW LLC		1,327.30	
00604659	LEVEL 3 FINANCING INC		621.44	
00604660	WASHINGTON TRUST BANK		7,394.93	
00604661	A TO Z RENTALS			370.26
00604662	ALCOBRA METALS INC			110.90
00604663	ATLAS SAND AND ROCK INC			1,758.44
00604664	KELLER SUPPLY COMPANY			5.40
00604665	M & L SUPPLY CO INC			1,611.53
00604666	SWIRE PACIFIC HOLDINGS, INC			1,878.04
00604667	ASCENDENT TECHNOLOGY GROUP I	10,939.76		
00604668	AT&T MOBILITY	12,526.98		

REPORT: PG3640
SYSTEM: FMSAP
USER: MANAGER
RUN NO: 31

CITY OF SPOKANE
COUNCIL CHECK RANGE/TOTAL

DATE: 08/05/24
TIME: 10:49
PAGE: 2

CHECK #	VENDOR	CITY	LIBRARY	PARKS
00604669	CENTURYLINK	396.62		
00604670	COMCAST	151.14		
00604671	FIRST ARRIVING IO INC	2,067.00		
00604672	YP AUTOMOTIVE INC	676.17		
00604673	KAISER FOUNDATION HEALTH OF	8,271.00		
00604676	PET EMERGENCY CLINIC	81.44		
00604677	SAFEWARE INC	52,501.62		
00604678	T-MOBILE USA INC	165.00		
00604679	WA STATE EMPLOYMENT SECURITY	55,761.93		
00604680	US BANK OR CITY OF SPOKANE		3,419.04	
00604717	SPOKANE COUNTY TITLE CO		3,419.04	
00604718	ADVANCED HEARING LLC	489.84		
00604719	JAMES T BURKE	83.96		
00604720	FAIRWINDS SPOKANE LLC	10,795.00		
00604721	KJERSTEN HERON PLLC	65.35		
00604722	JAMES KRAFT	3.99		
00604723	LANE POWELL PC	108.00		
00604724	ANDREW MASSIE	214.88		
00604725	ANGELA GRUNTE	110.87		
00604726	KEITH AND CINDY GAUTHIER	208.45		
00604727	K & B EXCAVATING INC	1,500.00		
00604728	SILAS & HEIDI PRATT	31.17		
00604729	COUGAR HEATING AND COOLING	45.00		
00604730	LUMEN	1,350.00		
00604731	MADDOG CONTRACTING LLC	60.00		
00604732	MAINSTREAM ELECTRIC LLC	15.00		
00604733	MORSE WESTERN HOMES LLC	650.00		
00604734	PATRIOT ELECTRIC AND LIGHTIN	45.00		
00604735	STURM HEATING INC	20.00		
00604736	ESTATE OF HARLAN D DOUGLASS	59,207.30		
00604737	A-L COMPRESSED GASES INC	76.00		
00604738	BLACK REALTY MANAGEMENT	38.00		
00604739	GOODALE & BARBIERI	202.00		
00604740	KIEMLE & HAGOOD	202.00		
00604741	LT REAL ESTATE	44.00		
00604742	PRO BUILDERS	38.00		
00604743	MICHAEL D LOWDON	136.00		
00604744	MULTICARE HEALTH SYSTEMS	61.00		
00604745	TERESA S ROSADOVELAZQUEZ	112.50		
00604746	TERRY CARE GROUP LLC	9,180.00		
00604747	TK ELEVATOR CORPORATION	408.75		
00604748	CLIFFORD WALTER	169.00		
00604749	CENTURYLINK			231.12
00604750	COMCAST			205.05
00604751	CONSISTENT CARE SERVICES	31,250.00		
00604752	CENTURYLINK	151.53		
00604753	COMCAST	214.91		
00604754	JUSTIN C FREEMAN	140.92		
00604755	VALLEY EMPIRE COLLECTION	90.47		
00604756	SPOKANE REGIONAL HEALTH DIST	1,020.66		
00604757	SPOKANE REGIONAL HEALTH DIST	19,805.58		
00604758	US BANK CORPORATE TRUST SVCS	350.00		
00604759	US BANK CORPORATE TRUST SVCS	350.00		

REPORT: PG3640
SYSTEM: FMSAP
USER: MANAGER
RUN NO: 31

CITY OF SPOKANE
COUNCIL CHECK RANGE/TOTAL

DATE: 08/05/24
TIME: 10:49
PAGE: 3

CHECK #	VENDOR	CITY	LIBRARY	PARKS
00604760	US BANK CORPORATE TRUST SVCS	350.00		

00604761	US BANK CORPORATE TRUST SVCS	350.00		
00604762	US BANK CORPORATE TRUST SVCS	200.00		
00604763	US BANK CORPORATE TRUST SVCS	350.00		
00604764	REMELISA CULLITAN		87.70	
00604765	Edward Gooden		150.00	
00604766	Jessica Martin		150.00	
00604767	Renee Raidt		75.00	
00604768	ANDREW ANDERSON FURGESON		2,850.00	
00604769	SPOKANE CITY TREASURER		10,481.14	
00604770	THE HARTFORD		711.00	
00604771	WA STATE PATROL		22.00	
00604772	WILDLIFE COLLECTIONS LLC			2,543.40
00604773	TOWN MILLS CRAFT CENTRE INC			1,548.30
00604774	SWIRE PACIFIC HOLDINGS, INC			16,668.46
00604775	DORA ANN HUNTER	100.00		
00604776	CARMEN PACHECO-JONES	100.00		
00604777	STEPHANIE SIJOHN	100.00		
00604778	SPOKANE CITY TREASURER	7,958.59		
70000450	ALASKA RUBBER GROUP INC			111.80
70000451	NORTHWEST INDUSTRIAL SERVICE			73.58
70000452	ANATEK LABS INC	40.00		
70000453	EVERGREEN STATE TOWING LLC	1,192.46		
70000454	GALLS LLC			91.38
70000455	HORIZON DISTRIBUTORS			3,669.00
70000456	HYDRAULICS PLUS INC	1,024.21		
70000457	SITEONE LANDSCAPE SUPPLY LLC			4,136.08
70000458	PEROVICH PARTNERS INC			430.89
70000459	WESTERN STATES EQUIPMENT CO			275.09
70000460	ACI NORTHWEST INC			4,985.57
70000461	CINTAS CORPORATION		38.15	
70000462	GALLS LLC	185.90		17.12
70000463	HORIZON DISTRIBUTORS			32.53
70000464	KERSHAW INC	2,739.72		
70000465	NATIONAL COLOR GRAPHICS INC		3,879.31	
70000466	NORCO INC	170.82		
70000467	OVERDRIVE INC		13,022.78	
70000468	PLANET TURF			802.34
70000469	SITEONE LANDSCAPE SUPPLY LLC	12.63		188.27
70000470	BRANOM OPERATING COMPANY LLC	1,766.16		
70000471	GALLS LLC	21,317.51		
70000472	GORDON TRUCK CENTERS INC DBA	160,162.99		
70000473	HUGHES FIRE EQUIPMENT INC	5,002.05		
70000474	OXARC INC	16,861.06		
70000475	ALASKA RUBBER GROUP INC	180.53		
70000476	NORTHWEST INDUSTRIAL SERVICE			645.00
70000477	NORCO INC	92.53		
70000478	SITEONE LANDSCAPE SUPPLY LLC	54.89		
70000479	CINTAS CORPORATION	3,946.36	38.15	
70000480	NATIONAL COLOR GRAPHICS INC			1,019.15
70000481	OXARC INC			43,332.93
70000482	TRAFFIC SAFETY SUPPLY INC	6,828.85		
80131867	AHBL INC			2,612.75

REPORT: PG3640
SYSTEM: FMSAP
USER: MANAGER
RUN NO: 31

CITY OF SPOKANE
COUNCIL CHECK RANGE/TOTAL

DATE: 08/05/24
TIME: 10:49
PAGE: 4

CHECK #	VENDOR	CITY	LIBRARY	PARKS
80131868	AVISTA UTILITIES			101,940.44
80131869	THE FA BARTLETT TREE EXPERT			1,558.70
80131870	BATTERY SYSTEMS INC			99.69
80131871	BEARING DISTRIBUTORS INC			38.59
80131872	BUDINGER & ASSOCIATES INC	14,778.00		

80131873	CAMTEK INC	218.00	
80131874	CARL MAXEY CENTER	75,837.14	
80131875	CENTER FOR SUSTAINABLE	11,600.00	
80131876	CLARY LONGVIEW LLC	282,087.16	
80131877	CONSOLIDATED ELECTRICAL	7,563.78	
80131878	CONTRACT DESIGN ASSOCIATES I	2,949.49	
80131879	CONTROL SOLUTIONS NW INC	613.12	
80131880	COPIERS NORTHWEST INC	3,660.65	
80131881	COPPER STATE BOLT & NUT CO		20.68
80131882	CUMMINS INC	2,801.14	
80131883	DEVRIES INFORMATION MANAGEME	17.10	
80131884	EDGE CONSTRUCTION SUPPLY		192.93
80131885	FASTENAL CO		1,004.36
80131886	FERGUSON ENTERPRISES INC		572.25
80131887	FINLEY BUTTES LIMITED	211,163.05	
80131888	FIREPOWER INC	294.32	
80131889	FOUR SEASONS SERVICES INC	1,808.97	
80131890	FRANCIS AVENUE HARDWARE		873.92
80131891	GEOENGINEERS INC	290,339.00	
80131892	GRAINGER INC		4.36
80131893	HASA INC	15,571.57	
80131894	HOME DEPOT USA INC		148.49
80131895	INFINITE INNOVATIONS LLC	6,245.30	
80131896	LANGUAGE SERVICES ASSOC INC	127.71	
80131897	LAWRENCE B STONE PROPERTIES	28,381.73	
80131898	LSB CONSULTING ENGINEERS PLL	10,370.30	
80131899	MAKERS ARCHITECTURE & URBAN	3,350.06	
80131900	MARTIN LUTHER KING JR FAMILY	511.83	
80131901	MCMILLEN INC	19,090.00	
80131902	MUTUAL MATERIALS CO INC		688.27
80131903	CHARLES H NEU		473.50
80131904	NORTHWEST FENCE COMPANY INC		4,041.45
80131905	NORTHWEST OPEN ACCESS NETWOR	3,600.00	
80131906	NOVUS AUTO GLASS	1,897.65	
80131907	OIL RE-REFINING CO INC	367.50	
80131908	ORACLE AMERICA INC	53,750.78	
80131909	PARAMETRIX INC	10,197.50	
80131910	PERFORMANCE SYSTEMS		964.12
80131911	QUANTIX INC/ENTERTAINMENT		557.93
80131912	SHERWIN WILLIAMS CO	32.54	
80131913	SHI CORP	278.99	
80131914	MATT HOUSTON	650.00	
80131915	SPOKANE NEIGHBORHOOD ACTION	31.46	
80131916	SPECIALTY MOBILE MIX INC		599.50
80131917	KRIS KANDY		630.00
80131918	HESTON HARDWARE		258.59
80131919	SPOKANE EMERGENCY PHYSICIANS	8,265.98	
80131920	SPOKANE POWER TOOL & HDWE		225.57

REPORT: PG3640

CITY OF SPOKANE

DATE: 08/05/24

SYSTEM: FMSAP

COUNCIL CHECK RANGE/TOTAL

TIME: 10:49

USER: MANAGER

PAGE: 5

RUN NO: 31

CHECK #	VENDOR	CITY	LIBRARY	PARKS
80131921	COWLES PUBLISHING COMPANY	104.84		
80131922	STONEWAY ELECTRIC SUPPLY			183.87
80131923	TARGETSOLUTIONS LEARNING LLC	10,951.78		
80131924	TERRAIN PROGRAMS	48,000.00		
80131925	AARON THEISEN			425.00
80131926	TRUEPOINT SOLUTIONS LLC	1,737.34		
80131927	URM STORES INC			900.84
80131928	VERIZON WIRELESS	85.52		4,449.96
80131929	VERTIV CORPORATION	3,276.27		

80131930	VOLT MANAGEMENT CORP	16,896.00		
80131931	WAPAL FUND	273.28		
80131932	WEAR-TEK INC	10,769.36		
80131933	WESTERN EQUIPMENT DISTRIBUTO			260.23
80131934	WESTERN GLOVE INC			250.59
80131935	WHITE CAP LP			43.60
80131936	WILBUR ELLIS COMPANY			383.89
80131937	YWCA	5,850.78		
80131938	NICHOLAS ANTHONY FEDERICI	3,500.00		
80131940	RICHARD PERRY	176.50		
80131941	AVISTA UTILITIES		9,072.09	
80131942	BAKER & TAYLOR BOOKS		3,731.94	
80131943	C & C YARD CARE	2,383.01		
80131944	CAMTEK INC			10,791.00
80131945	CENGAGE LEARNING INC		767.39	
80131946	COLEMAN OIL COMPANY LLC			2,471.81
80131947	CONCESSION SUPPLY/DIV OF			554.48
80131948	SHELLEY FAIRWEATHER-VEGA		128.62	
80131949	FASTENAL CO			611.14
80131950	FERGUSON ENTERPRISES INC			101.91
80131951	HAMILTON CONSTRUCTION CO	557,313.35		
80131952	INGRAM LIBRARY SERVICES LLC		320.39	
80131953	CPM DEVELOPMENT CORP DBA	1,853,228.75		
80131954	KEY CODE MEDIA INC	48,983.84		
80131955	LIFE ASSIST INC	212.01		
80131956	LOOMIS ARMORED US INC	1,233.84		
80131957	LAURI WEINMANN	15,057.04		
80131958	MCKINSTRY CO LLC		840.00	
80131959	MIDWEST TAPE		35.98	
80131960	MK SOLUTIONS INC		2,168.01	
80131961	NAPA AUTO PARTS			4.56
80131962	NORTHWEST GRADING INC	255,235.51		
80131963	PRO MECHANICAL SERVICES INC	440.15		
80131964	PROFORMA	1,340.71		
80131965	RW LOTHROP ENTERPRISES			203.83
80131966	SEAWESTERN FIRE APPARATUS &	481.96		
80131967	SHAMROCK PAVING CO/DIV OF	854,446.40		
80131968	SHI CORP	308.36		
80131969	ROMAN OBEREMOK	2,650.00		
80131970	SPOKANE POLICE CHAPLAINCY	10,475.00		
80131971	SPOKANE PRO CARE INC	432.73		
80131972	URM STORES INC			435.53
80131973	US BANK P CARD PAYMENTS	77,677.68		
80131974	WHEELER MANUFACTURING CO, IN			514.50

REPORT: PG3640
SYSTEM: FMSAP
USER: MANAGER
RUN NO: 31

CITY OF SPOKANE
COUNCIL CHECK RANGE/TOTAL

DATE: 08/05/24
TIME: 10:49
PAGE: 6

CHECK #	VENDOR	CITY	LIBRARY	PARKS
80131975	WILBUR ELLIS COMPANY			300.92
80131976	WON-DOOR CORPORATION		768.00	
80131977	REBEKAH MACE		49.22	
80131978	NEIL, MASON		58.29	
80131979	ACTION MATERIALS	1,411.59		
80131980	VYANET OPERATIONS GROUP dba	2,014.86		
80131981	ALSCO DIVISION OF ALSCO INC	19.02		
80131982	AMERICAN AVK COMPANY	21,949.82		
80131984	AVISTA CORPORATION	1,079.17		
80131985	AVISTA UTILITIES	369.74		
80131986	BUDINGER & ASSOCIATES INC	8,503.62		
80131987	COLEMAN OIL COMPANY LLC	13,085.74		
80131988	CONSOLIDATED ELECTRICAL	486.41		

80131989	CONTECH ENGINEERED SOLUTIONS	5,395.50	
80131990	COPIERS NORTHWEST INC	3,648.25	
80131991	CORE & MAIN LP	32,325.59	
80131992	L N CURTIS & SONS	484.46	
80131993	DELL MARKETING LP	27,155.95	
80131994	GWP HOLDINGS LLC	558,477.79	
80131995	ENNIS FLINT INC	5,487.71	
80131996	FASTENAL CO	3,409.99	
80131997	GORLEY LOGISTICS LLC	307.72	
80131998	GOODALE & BARBIERI COMPANY	3,781.54	
80131999	H D FOWLER COMPANY	2,872.86	
80132000	INLAND POWER & LIGHT CO	793.01	
80132001	LIFE ASSIST INC	263.34	
80132002	LOOMIS ARMORED US INC	4,206.08	
80132003	MCGARD LLC	46,804.00	
80132004	MOTION INDUSTRIES INC	3,965.44	
80132005	OAC SERVICES INC	12,554.58	
80132006	PARAMETRIX INC	14,105.00	
80132007	PICTOMETRY INTERNATIONAL COR	2,725.00	
80132008	PREMERA BLUE CROSS OR	923,693.69	
80132009	RAY TURF FARMS INC	33.54	
80132010	SPOKANE COUNTY TREASURER	5,617.00	
80132011	STARPLEX CORP	30,705.67	
80132012	STERICYCLE INC	712.30	
80132013	TEDDER INDUSTRIES LLC	61.88	
80132014	VERIZON WIRELESS	128.28	
80132016	JORDAN JOHNSON	408.00	
80132017	ALLIED ENVELOPE	79.42	
80132018	ALSCO DIVISION OF ALSCO INC	120.55	4.58
80132019	AVISTA CORPORATION	12,379.98	
80132020	BUDINGER & ASSOCIATES INC	1,680.00	
80132021	BUREAU VERITAS TECHNICAL	35,072.00	
80132022	CATHOLIC CHARITIES	70,726.15	
80132023	CHASE YOUTH FOUNDATION	11,250.00	
80132024	COMPUNET INC	154,202.21	
80132025	STEVE CONNER		23,725.71
80132026	COPIERS NORTHWEST INC	385.44	
80132027	COYLE OUTSIDE LLC		3,346.00
80132028	CREEK AT QUALCHAN GOLF COURS		21,281.50
80132029	L N CURTIS & SONS	132.12	

REPORT: PG3640
SYSTEM: FMSAP
USER: MANAGER
RUN NO: 31

CITY OF SPOKANE
COUNCIL CHECK RANGE/TOTAL

DATE: 08/05/24
TIME: 10:49
PAGE: 7

CHECK #	VENDOR	CITY	LIBRARY	PARKS
80132030	DELL MARKETING LP	63,263.39		
80132031	DESIMONE CONSULTING LLC	13,333.00		
80132032	DEVRIES INFORMATION MANAGEME	264.10		
80132033	ECONOLITE CONTROL PRODUCTS I	4,591.08		
80132034	FEDERAL EXPRESS CORP/DBA FED	25.53		
80132035	GORLEY LOGISTICS LLC	199.60		
80132036	FOSTER GARVEY PC	13,281.50		
80132037	FOUR SEASONS SERVICES INC	755.17		
80132038	FRONTIER BEHAVIORAL HEALTH	3,510.27		
80132039	INTERFAITH HOSPITALITY	22,200.78		
80132040	INTERMOUNTAIN SIGN & SAFETY	37,169.00		
80132041	JRM ENTERPRISES INC	5,275.00		
80132042	LIFEWISE ASSURANCE CO	36,728.59		
80132043	LUTHERAN COMMUNITY SERVICES	36,131.27		
80132044	MARTIN LUTHER KING JR FAMILY	20,911.92		
80132045	MEGAMATION LLC	595.00		
80132046	MYTHICS LLC	1,195.22		

80132047	NE COMMUNITY CENTER ASSN	33,000.00		
80132048	NORTH RIDGE HOUSE INC	9,921.00		
80132049	PACIFIC NW EMERGENCY EQUIPME	93.52		
80132050	PARTNERS WITH FAMILIES &	16,758.96		
80132051	PROTHMAN COMPANY	12,333.32		
80132052	SANDBAGGERS CLUB LLC			18,961.16
80132053	SEW UNIQUELY YOU			625.80
80132054	SHI CORP	2,690.73		
80132055	SPOKANE NEIGHBORHOOD ACTION	26,538.63		
80132056	SOUTHWEST SPOKANE COMMUNITY	19,426.25		
80132057	W B SPRAGUE COMPANY INC			269.79
80132058	SUMMIT LAW GROUP PLLC	1,136.00		
80132059	T & T GOLF MANAGEMENT INC			27,290.85
80132060	THOMSON WEST	4,815.37		
80132061	TRANSPORT EQUIPMENT INC	116,507.94		
80132062	US BANK OR CITY TREASURER	48,692.03		
80132063	VOLT MANAGEMENT CORP	21,957.30		
80132064	VOLUNTEERS OF AMERICA OF	181,465.74		
80132065	WEST CENTRAL COMMUNITY	46,648.00		
80132066	YWCA	58,225.22		
80132067	PIA H CHRISTENSEN	1,100.00		
80132068	KEVIN HAUGHTON	639.34		
80132069	BENJAMIN M PRICE	778.00		
80132070	MICHAEL VAUGHAN	696.20		
80132071	A2Z INTERPRETING LLC		137.14	
80132072	ABLE CLEAN-UP TECHNOLOGIES I	1,220.00		
80132073	AVISTA UTILITIES	444.30	196.38	
80132074	CINTAS CORPORATION NO 2	552.34		
80132075	COLEMAN OIL COMPANY LLC			3,526.09
80132076	COPIERS NORTHWEST INC	1,344.58		
80132077	CUESTA SPRINGS ICE COMPANY O	202.74		
80132078	DELL MARKETING LP			248.16
80132079	DELTA DENTAL OF WASHINGTON	35,895.13		
80132080	DOUGLAS CO INC			3,248.50
80132081	ELECTRIC CITY INC			705.78
80132082	FEDERAL EXPRESS CORP/DBA FED	13.71		

REPORT: PG3640
SYSTEM: FMSAP
USER: MANAGER
RUN NO: 31

CITY OF SPOKANE
COUNCIL CHECK RANGE/TOTAL

DATE: 08/05/24
TIME: 10:49
PAGE: 8

CHECK #	VENDOR	CITY	LIBRARY	PARKS
80132083	H D FOWLER COMPANY	6,457.80		
80132084	HASKINS STEEL CO INC	352.48		
80132085	HOME DEPOT USA INC		1,266.56	
80132086	INDUSTRIAL BOLT & SUPPLY INC		827.79	
80132087	KAISER FOUNDATION HEALTH PLA	149,828.48		
80132088	KPFF CONSULTING ENGINEERS	62,132.06		
80132089	MACON SUPPLY INC	4,106.52		
80132090	MCGARD LLC	51,392.16		
80132091	NORTHEAST PUBLIC DEVELOPMENT	2,840.57		
80132092	PERFORMANCE SYSTEMS			302.42
80132093	RIVER PARK SQUARE LLC	200.00		
80132094	SOIL TECHNOLOGIES CORP			1,466.36
80132095	STANTEC CONSULTING SERVICES	7,436.25		
80132096	VERIZON WIRELESS	910.72		
80132097	WCP SOLUTIONS			1,193.55
80132098	WESTERN EQUIPMENT DISTRIBUTO			2,175.09
80132099	CATHERINE G BAKKEN		63.48	
80132100	GINA COOPER		58.58	
80132101	DEVIKA GATES		200.00	
80132102	LARRY B HUGHES		23.45	
80132103	NEIL, MASON		16.34	

80132104 KAYA KM STONE

	3,182.37	
-----	-----	-----
9,082,447.55	72,256.16	345,003.60
		=====
CITYWIDE TOTAL:		9,499,707.31

0020 - NONDEPARTMENTAL

FOSTER GARVEY PC	LEGAL SERVICES ACH PMT NO. - 80132036	13,281.50
LANE POWELL PC	LEGAL SERVICES CHECK NO. - 00604723	108.00
SUMMIT LAW GROUP PLLC	LEGAL SERVICES ACH PMT NO. - 80132058	1,136.00
US BANK CORPORATE TRUST SVCS	OTHER MISC CHARGES CHECK NO. - 00604763	1,950.00
TOTAL FOR 0020 - NONDEPARTMENTAL		16,475.50

0030 - POLICE OMBUDSMAN

DELL MARKETING LP %DELL USA LP	COMPUTERS ACH PMT NO. - 80132030	238.13
DELL MARKETING LP %DELL USA LP	MINOR EQUIPMENT ACH PMT NO. - 80132030	286.16
US BANK P CARD PAYMENTS	OTH DUES/SUBSCRIPTNS/MEMBERSHP ACH PMT NO. - 80131973	500.00
US BANK P CARD PAYMENTS	REGISTRATION/SCHOOLING ACH PMT NO. - 80131973	25.00
TOTAL FOR 0030 - POLICE OMBUDSMAN		1,049.29

0100 - GENERAL FUND

LUMEN 1020 E CATALDO AVE	PERMIT REFUNDS PAYABLE CHECK NO. - 00604730	1,350.00
TERRAIN PROGRAMS	GRANT CASH PASS THRU ACCOUNT ACH PMT NO. - 80131924	48,000.00
US BANK P CARD PAYMENTS	ACCOUNTS RECEIVABLE-MISC ACH PMT NO. - 80131973	109.70
US BANK P CARD PAYMENTS	PCARD ADVANCE PYMT REC ACH PMT NO. - 80131973	222,372.85-
US BANK P CARD PAYMENTS	TRAVEL CARD ADVANCE PYMT ACH PMT NO. - 80131973	2,073.83
WA STATE DEPT OF NATURAL RESOURCES	GRANT CASH PASS THRU ACCOUNT CHECK NO. - 00604655	26,934.37
TOTAL FOR 0100 - GENERAL FUND		143,904.95-

HONORABLE MAYOR
AND COUNCIL MEMBERS

08/05/24
PAGE 3

PROCESSING OF VOUCHERS RESULTS IN CLAIMS AS FOLLOWS:

0230 - CIVIL SERVICE

US BANK P CARD PAYMENTS	ADVERTISING
-------------------------	-------------

	ACH PMT NO. - 80131973	469.15
US BANK P CARD PAYMENTS	NON-TRAVEL MEALS/LGHT RFRSHMT ACH PMT NO. - 80131973	79.34
US BANK P CARD PAYMENTS	OFFICE SUPPLIES ACH PMT NO. - 80131973	41.18
VERIZON WIRELESS	CELL PHONE ACH PMT NO. - 80132014	128.28
TOTAL FOR 0230 - CIVIL SERVICE		717.95

0260 - CITY CLERK		

ALLIED ENVELOPE	PRINTING/BINDING/REPRO ACH PMT NO. - 80132017	79.42
US BANK P CARD PAYMENTS	OTH DUES/SUBSCRIPTNS/MEMBERSHP ACH PMT NO. - 80131973	214.00
TOTAL FOR 0260 - CITY CLERK		293.42

0300 - HUMAN SERVICES		

US BANK P CARD PAYMENTS	OPERATING SUPPLIES ACH PMT NO. - 80131973	950.64
TOTAL FOR 0300 - HUMAN SERVICES		950.64

0320 - COUNCIL		

DELL MARKETING LP %DELL USA LP	MINOR EQUIPMENT ACH PMT NO. - 80132030	397.06
DESIMONE CONSULTING LLC	PROFESSIONAL SERVICES ACH PMT NO. - 80132031	13,333.00
NICHOLAS ANTHONY FEDERICI	PROFESSIONAL SERVICES ACH PMT NO. - 80131938	3,500.00
PROFORMA	OPERATING SUPPLIES ACH PMT NO. - 80131964	1,340.71
STARPLEX CORP	OTHER MISC CHARGES ACH PMT NO. - 80132011	487.35
US BANK P CARD PAYMENTS	OFFICE SUPPLIES ACH PMT NO. - 80131973	430.92
HONORABLE MAYOR AND COUNCIL MEMBERS		08/05/24 PAGE 4
PROCESSING OF VOUCHERS RESULTS IN CLAIMS AS FOLLOWS:		
US BANK P CARD PAYMENTS	OTH DUES/SUBSCRIPTNS/MEMBERSHP ACH PMT NO. - 80131973	17.77
US BANK P CARD PAYMENTS	OTHER MISC CHARGES ACH PMT NO. - 80131973	327.00
US BANK P CARD PAYMENTS	REGISTRATION/SCHOOLING	

ACH PMT NO. - 80131973 71.21

TOTAL FOR 0320 - COUNCIL 19,905.02

0330 - PUBLIC AFFAIRS/COMMUNICATIONS

US BANK P CARD PAYMENTS CONTRACTUAL SERVICES
ACH PMT NO. - 80131973 2,129.78

TOTAL FOR 0330 - PUBLIC AFFAIRS/COMMUNICATIONS 2,129.78

0350 - COMMUNITY CENTERS

BUREAU VERITAS TECHNICAL CONTRACTUAL SERVICES
ASSESSMENTS LLC ACH PMT NO. - 80132021 35,072.00

TOTAL FOR 0350 - COMMUNITY CENTERS 35,072.00

0370 - ENGINEERING SERVICES

DELL MARKETING LP COMPUTERS
%DELL USA LP ACH PMT NO. - 80132030 3,029.83

RIVER PARK SQUARE LLC PARKING/TOLLS (LOCAL)
ACH PMT NO. - 80132093 200.00

US BANK P CARD PAYMENTS MINOR EQUIPMENT
ACH PMT NO. - 80131973 33.32

US BANK P CARD PAYMENTS OFFICE FURNITURE (NON CAPITAL)
ACH PMT NO. - 80131973 272.49

US BANK P CARD PAYMENTS OFFICE SUPPLIES
ACH PMT NO. - 80131973 925.19

US BANK P CARD PAYMENTS OPERATING SUPPLIES
ACH PMT NO. - 80131973 121.53

TOTAL FOR 0370 - ENGINEERING SERVICES 4,582.36

0410 - FINANCE

LOOMIS ARMORED US INC CONTRACTUAL SERVICES
ACH PMT NO. - 80132002 633.93

HONORABLE MAYOR 08/05/24
AND COUNCIL MEMBERS PAGE 5

PROCESSING OF VOUCHERS RESULTS IN CLAIMS AS FOLLOWS:

US BANK P CARD PAYMENTS OTH DUES/SUBSCRIPTNS/MEMBERSHP
ACH PMT NO. - 80131973 60.69

US BANK P CARD PAYMENTS REGISTRATION/SCHOOLING
ACH PMT NO. - 80131973 298.00

TOTAL FOR 0410 - FINANCE 992.62

0470 - HISTORIC PRESERVATION

US BANK P CARD PAYMENTS	REGISTRATION/SCHOOLING ACH PMT NO. - 80131973	48.07
VERIZON WIRELESS	CELL PHONE ACH PMT NO. - 80131928	85.52
TOTAL FOR 0470 - HISTORIC PRESERVATION		----- 133.59

0500 - LEGAL

COPIERS NORTHWEST INC	OPERATING RENTALS/LEASES ACH PMT NO. - 80132026	385.44
GORLEY LOGISTICS LLC dba FIKES NORTHWEST	OPERATING SUPPLIES ACH PMT NO. - 80132035	24.95
TERESA S ROSADOVELAZQUEZ	LEGAL SERVICES CHECK NO. - 00604745	112.50
THOMSON WEST WEST PUBLISHING PAYMENT CTR	PUBLICATIONS ACH PMT NO. - 80132060	4,815.37
TK ELEVATOR CORPORATION	PROFESSIONAL SERVICES CHECK NO. - 00604747	408.75
US BANK P CARD PAYMENTS	CLE TRAVEL ACH PMT NO. - 80131973	315.00
US BANK P CARD PAYMENTS	OFFICE SUPPLIES ACH PMT NO. - 80131973	156.47
YWCA	PROFESSIONAL SERVICES ACH PMT NO. - 80131937	5,850.78
TOTAL FOR 0500 - LEGAL		----- 12,069.26

0520 - MAYOR

COPIERS NORTHWEST INC	OPERATING RENTALS/LEASES ACH PMT NO. - 80132076	140.81
US BANK P CARD PAYMENTS	NON-TRAVEL MEALS/LGHT RFRSHMT ACH PMT NO. - 80131973	107.49

HONORABLE MAYOR AND COUNCIL MEMBERS 08/05/24
PAGE 6

PROCESSING OF VOUCHERS RESULTS IN CLAIMS AS FOLLOWS:

US BANK P CARD PAYMENTS	OFFICE SUPPLIES ACH PMT NO. - 80131973	62.68
TOTAL FOR 0520 - MAYOR		----- 310.98

0550 - NEIGHBORHOOD SERVICES

US BANK P CARD PAYMENTS	MISC SERVICES/CHARGES ACH PMT NO. - 80131973	24.00
US BANK P CARD PAYMENTS	OFFICE SUPPLIES ACH PMT NO. - 80131973	16.10

US BANK P CARD PAYMENTS	OPERATING SUPPLIES	
	ACH PMT NO. - 80131973	49.77

TOTAL FOR 0550 - NEIGHBORHOOD SERVICES 89.87

0560 - MUNICIPAL COURT

US BANK P CARD PAYMENTS	OFFICE SUPPLIES	
	ACH PMT NO. - 80131973	139.62

US BANK P CARD PAYMENTS	OPERATING SUPPLIES	
	ACH PMT NO. - 80131973	4.34

US BANK P CARD PAYMENTS	OTH DUES/SUBSCRIPTNS/MEMBERSHP	
	ACH PMT NO. - 80131973	3,863.29

US BANK P CARD PAYMENTS	SOFTWARE (NONCAPITALIZED)	
	ACH PMT NO. - 80131973	38.00

VALLEY EMPIRE COLLECTION	CASH OVER/SHORT	
8817 E MISSION SUITE 101	CHECK NO. - 00604755	90.47

TOTAL FOR 0560 - MUNICIPAL COURT 4,135.72

0620 - HUMAN RESOURCES

PROTHMAN COMPANY	CONTRACTUAL SERVICES	
	ACH PMT NO. - 80132051	12,333.32

TOTAL FOR 0620 - HUMAN RESOURCES 12,333.32

0650 - PLANNING SERVICES

MAKERS ARCHITECTURE & URBAN DESIGN LLP	CONTRACTUAL SERVICES	
	ACH PMT NO. - 80131899	3,350.06

US BANK P CARD PAYMENTS	OFFICE SUPPLIES	
	ACH PMT NO. - 80131973	45.21

HONORABLE MAYOR AND COUNCIL MEMBERS 08/05/24
PAGE 7

PROCESSING OF VOUCHERS RESULTS IN CLAIMS AS FOLLOWS:

US BANK P CARD PAYMENTS	OTH DUES/SUBSCRIPTNS/MEMBERSHP	
	ACH PMT NO. - 80131973	15.99

US BANK P CARD PAYMENTS	PUBLICATIONS	
	ACH PMT NO. - 80131973	62.35

US BANK P CARD PAYMENTS	REGISTRATION/SCHOOLING	
	ACH PMT NO. - 80131973	40.00

TOTAL FOR 0650 - PLANNING SERVICES 3,513.61

0680 - POLICE

AVISTA CORPORATION	UTILITY LIGHT/POWER SERVICE	
	ACH PMT NO. - 80131984	1,064.26

AVISTA CORPORATION	UTILITY NATURAL GAS	
--------------------	---------------------	--

	ACH PMT NO. - 80131984	14.91
COMCAST	IT/DATA SERVICES CHECK NO. - 00604670	3,157.72
FEDERAL EXPRESS CORP/DBA FEDEX	POSTAGE ACH PMT NO. - 80132082	13.71
FIRST ARRIVING IO INC	SOFTWARE MAINTENANCE CHECK NO. - 00604671	2,067.00
GALLS LLC	CLOTHING CREDIT CARD PMT NO. - 70000471	10,090.88
GALLS LLC	OPERATING SUPPLIES CREDIT CARD PMT NO. - 70000471	2,932.11
GALLS LLC	PROTECTIVE GEAR/CLOTHING CREDIT CARD PMT NO. - 70000471	1,134.23
GORLEY LOGISTICS LLC dba FIKES NORTHWEST	OPERATING SUPPLIES ACH PMT NO. - 80131997	83.17
KAISER FOUNDATION HEALTH OF WASHINGTON	MEDICAL SERVICES CHECK NO. - 00604673	2,636.00
KERSHAW INC	OFFICE SUPPLIES CREDIT CARD PMT NO. - 70000464	2,739.72
LAURI WEINMANN	CONTRACTUAL SERVICES ACH PMT NO. - 80131957	15,057.04
LIFE ASSIST INC	OPERATING SUPPLIES ACH PMT NO. - 80132001	263.34
LOOMIS ARMORED US INC	CONTRACTUAL SERVICES ACH PMT NO. - 80131956	1,233.84
PET EMERGENCY CLINIC	VETERINARY SERVICES CHECK NO. - 00604676	81.44

HONORABLE MAYOR
AND COUNCIL MEMBERS

08/05/24
PAGE 8

PROCESSING OF VOUCHERS RESULTS IN CLAIMS AS FOLLOWS:

SHI CORP	SOFTWARE MAINTENANCE ACH PMT NO. - 80132054	2,323.18
SPOKANE POLICE CHAPLAINCY BOARD	CONTRACTUAL SERVICES ACH PMT NO. - 80131970	10,475.00
TEDDER INDUSTRIES LLC	MINOR EQUIPMENT ACH PMT NO. - 80132013	61.88
T-MOBILE USA INC	MISC SERVICES/CHARGES CHECK NO. - 00604678	165.00
US BANK P CARD PAYMENTS	BACKGROUND CHECKS ACH PMT NO. - 80131973	426.84
US BANK P CARD PAYMENTS	CLOTHING ACH PMT NO. - 80131973	581.40
US BANK P CARD PAYMENTS	EQUIPMENT REPAIRS/MAINTENANCE ACH PMT NO. - 80131973	65.00
US BANK P CARD PAYMENTS	IT/DATA SERVICES ACH PMT NO. - 80131973	171.91

US BANK P CARD PAYMENTS	MINOR EQUIPMENT ACH PMT NO. - 80131973	2,020.49
US BANK P CARD PAYMENTS	MISC SERVICES/CHARGES ACH PMT NO. - 80131973	43.94
US BANK P CARD PAYMENTS	NON-TRAVEL MEALS/LGHT RFRSHMT ACH PMT NO. - 80131973	181.88
US BANK P CARD PAYMENTS	OFFICE SUPPLIES ACH PMT NO. - 80131973	1,506.40
US BANK P CARD PAYMENTS	OPERATING SUPPLIES ACH PMT NO. - 80131973	5,816.08
US BANK P CARD PAYMENTS	OTH DUES/SUBSCRIPTNS/MEMBERSHP ACH PMT NO. - 80131973	592.60
US BANK P CARD PAYMENTS	POSTAGE ACH PMT NO. - 80131973	239.38
US BANK P CARD PAYMENTS	PRINTING/BINDING/REPRO ACH PMT NO. - 80131973	392.23
US BANK P CARD PAYMENTS	PUBLICATIONS ACH PMT NO. - 80131973	30.60
US BANK P CARD PAYMENTS	REGISTRATION/SCHOOLING ACH PMT NO. - 80131973	8,259.00
US BANK P CARD PAYMENTS	TUITION REIMBURSEMENT ACH PMT NO. - 80131973	2,266.44
VYANET OPERATIONS GROUP dba ALLIED FIRE & SECURITY	MISC REPAIRS/MAINTENANCE ACH PMT NO. - 80131980	2,014.86

HONORABLE MAYOR
AND COUNCIL MEMBERS

08/05/24
PAGE 9

PROCESSING OF VOUCHERS RESULTS IN CLAIMS AS FOLLOWS:

WA STATE DEPT OF REVENUE	CLOTHING -	26.82
WA STATE DEPT OF REVENUE	EQUIPMENT REPAIRS/MAINTENANCE -	5.85
WA STATE DEPT OF REVENUE	MINOR EQUIPMENT -	104.57
WA STATE DEPT OF REVENUE	OPERATING SUPPLIES -	17.66
WA STATE DEPT OF REVENUE	SOFTWARE MAINTENANCE -	186.03
TOTAL FOR 0680 - POLICE		80,544.41

0690 - COMMUNITY JUSTICE SERVICES

DS SERVICES OF AMERICA INC DBA CRYSTAL SPRINGS	OFFICE SUPPLIES CHECK NO. - 00604616	45.10
US BANK P CARD PAYMENTS	OFFICE SUPPLIES ACH PMT NO. - 80131973	406.62

US BANK P CARD PAYMENTS	OPERATING SUPPLIES	
	ACH PMT NO. - 80131973	26.44

TOTAL FOR 0690 - COMMUNITY JUSTICE SERVICES 478.16

0700 - PUBLIC DEFENDER

COPIERS NORTHWEST INC	OPERATING RENTALS/LEASES	
	ACH PMT NO. - 80131990	466.21

US BANK P CARD PAYMENTS	MISC SERVICES/CHARGES	
	ACH PMT NO. - 80131973	32.49

US BANK P CARD PAYMENTS	OFFICE SUPPLIES	
	ACH PMT NO. - 80131973	705.82

TOTAL FOR 0700 - PUBLIC DEFENDER 1,204.52

0750 - COMMUNITY/ECONOMIC DEV SVC

US BANK P CARD PAYMENTS	MISC SERVICES/CHARGES	
	ACH PMT NO. - 80131973	21.67

US BANK P CARD PAYMENTS	OFFICE SUPPLIES	
	ACH PMT NO. - 80131973	4.68

US BANK P CARD PAYMENTS	OTH DUES/SUBSCRIPTNS/MEMBERSHP	
	ACH PMT NO. - 80131973	20.00

HONORABLE MAYOR AND COUNCIL MEMBERS 08/05/24
PAGE 10

PROCESSING OF VOUCHERS RESULTS IN CLAIMS AS FOLLOWS:

TOTAL FOR 0750 - COMMUNITY/ECONOMIC DEV SVC 46.35

1100 - STREET FUND

ECONOLITE CONTROL PRODUCTS INC	REPAIR & MAINTENANCE SUPPLIES	
	ACH PMT NO. - 80132033	4,591.08

ENNIS FLINT INC	REPAIR & MAINTENANCE SUPPLIES	
	ACH PMT NO. - 80131995	5,487.71

INTERMOUNTAIN SIGN & SAFETY INC	OPERATING SUPPLIES	
	ACH PMT NO. - 80132040	37,169.00

KAISER FOUNDATION HEALTH OF WASHINGTON	MEDICAL SERVICES	
	CHECK NO. - 00604673	1,419.00

MACON SUPPLY INC	REPAIR & MAINTENANCE SUPPLIES	
	ACH PMT NO. - 80132089	4,106.52

ROMAN OBEREMOK DBA SPOKANE CDL SCHOOL	REGISTRATION/SCHOOLING	
	ACH PMT NO. - 80131969	2,650.00

TRAFFIC SAFETY SUPPLY INC	REPAIR & MAINTENANCE SUPPLIES	
	CREDIT CARD PMT NO. - 70000482	6,828.85

US BANK P CARD PAYMENTS	OFFICE SUPPLIES	
	ACH PMT NO. - 80131973	65.35

US BANK P CARD PAYMENTS	OPERATING SUPPLIES	
-------------------------	--------------------	--

	ACH PMT NO. - 80131973	3,728.28
US BANK P CARD PAYMENTS	OTH DUES/SUBSCRIPTNS/MEMBERSHP ACH PMT NO. - 80131973	2,300.00
US BANK P CARD PAYMENTS	REGISTRATION/SCHOOLING ACH PMT NO. - 80131973	47.91-
US BANK P CARD PAYMENTS	REPAIR & MAINTENANCE SUPPLIES ACH PMT NO. - 80131973	1,940.26
TOTAL FOR 1100 - STREET FUND		----- 70,238.14

1200 - CODE ENFORCEMENT FUND

RICHARD PERRY	PERMITS/OTHER FEES ACH PMT NO. - 80131940	176.50
SHERWIN WILLIAMS CO	OPERATING SUPPLIES ACH PMT NO. - 80131912	32.54
US BANK P CARD PAYMENTS	MEDICAL SERVICES ACH PMT NO. - 80131973	220.00
US BANK P CARD PAYMENTS	OFFICE SUPPLIES ACH PMT NO. - 80131973	77.30

HONORABLE MAYOR
AND COUNCIL MEMBERS

08/05/24
PAGE 11

PROCESSING OF VOUCHERS RESULTS IN CLAIMS AS FOLLOWS:

US BANK P CARD PAYMENTS	OTH DUES/SUBSCRIPTNS/MEMBERSHP ACH PMT NO. - 80131973	0.99
US BANK P CARD PAYMENTS	PERSONAL PROTECTIVE EQUIPMENT ACH PMT NO. - 80131973	295.30
TOTAL FOR 1200 - CODE ENFORCEMENT FUND		----- 802.63

1300 - LIBRARY FUND

KAISER FOUNDATION HEALTH OF WASHINGTON	SAFETY SUPPLIES CHECK NO. - 00604673	130.00
US BANK P CARD PAYMENTS	ADVERTISING ACH PMT NO. - 80131973	339.00
US BANK P CARD PAYMENTS	CHEMICAL/LAB SUPPLIES ACH PMT NO. - 80131973	1,206.09
US BANK P CARD PAYMENTS	CONTRACTUAL SERVICES ACH PMT NO. - 80131973	389.01
US BANK P CARD PAYMENTS	IT/DATA SERVICES ACH PMT NO. - 80131973	605.59
US BANK P CARD PAYMENTS	LIBRARY BOOKS/OTHER MATERIALS ACH PMT NO. - 80131973	357.82
US BANK P CARD PAYMENTS	MINOR EQUIPMENT ACH PMT NO. - 80131973	4,839.74
US BANK P CARD PAYMENTS	MISC REPAIRS/MAINTENANCE ACH PMT NO. - 80131973	139.15

US BANK P CARD PAYMENTS	OPERATING SUPPLIES ACH PMT NO. - 80131973	6,838.41
US BANK P CARD PAYMENTS	OTH DUES/SUBSCRIPTNS/MEMBERSHP ACH PMT NO. - 80131973	704.65
US BANK P CARD PAYMENTS	PERMITS/OTHER FEES ACH PMT NO. - 80131973	1,080.00
US BANK P CARD PAYMENTS	PROFESSIONAL SERVICES ACH PMT NO. - 80131973	1,616.16
US BANK P CARD PAYMENTS	RECREATIONAL SUPPLIES ACH PMT NO. - 80131973	3,904.23
US BANK P CARD PAYMENTS	REGISTRATION/SCHOOLING ACH PMT NO. - 80131973	1,410.00
US BANK P CARD PAYMENTS	REPAIR & MAINTENANCE SUPPLIES ACH PMT NO. - 80131973	1,566.62
US BANK P CARD PAYMENTS	SAFETY SUPPLIES ACH PMT NO. - 80131973	318.66

HONORABLE MAYOR
AND COUNCIL MEMBERS

08/05/24
PAGE 12

PROCESSING OF VOUCHERS RESULTS IN CLAIMS AS FOLLOWS:

US BANK P CARD PAYMENTS	SMART PHONES, IPAD, TABLETS ACH PMT NO. - 80131973	871.96
WA STATE DEPT OF REVENUE	MINOR EQUIPMENT -	23.08
WA STATE DEPT OF REVENUE	OPERATING SUPPLIES -	37.22
TOTAL FOR 1300 - LIBRARY FUND		----- 26,377.39

1360 - MISCELLANEOUS GRANTS FUND

TERRAIN PROGRAMS	CONTRACTUAL SERVICES ACH PMT NO. - 80131924	48,000.00
TERRAIN PROGRAMS	GRANT CASH PASS THRU ACCOUNT ACH PMT NO. - 80131924	48,000.00-
US BANK P CARD PAYMENTS	CLOTHING ACH PMT NO. - 80131973	650.47
US BANK P CARD PAYMENTS	OPERATING SUPPLIES ACH PMT NO. - 80131973	325.63
US BANK P CARD PAYMENTS	PROFESSIONAL SERVICES ACH PMT NO. - 80131973	3,447.69
TOTAL FOR 1360 - MISCELLANEOUS GRANTS FUND		----- 4,423.79

1380 - TRAFFIC CALMING MEASURES

BUDINGER & ASSOCIATES INC	CONSTRUCTION OF FIXED ASSETS ACH PMT NO. - 80131986	114.24
---------------------------	--	--------

CAROL LAMBERT 1111 E PRINCETON AVE	SCHOOL ZONE SPEED CAMERA FINE CHECK NO. - 00604620	30.00
CPM DEVELOPMENT CORP DBA INLAND ASPHALT COMPANY	CONSTRUCTION OF FIXED ASSETS ACH PMT NO. - 80131953	9,978.64
TOTAL FOR 1380 - TRAFFIC CALMING MEASURES		10,122.88

1400 - PARKS AND RECREATION FUND

COMCAST	IT/DATA SERVICES CHECK NO. - 00604652	401.65
KAISER FOUNDATION HEALTH OF WASHINGTON	BACKGROUND CHECKS CHECK NO. - 00604673	1,260.00
US BANK P CARD PAYMENTS	ADVERTISING ACH PMT NO. - 80131973	2,003.38

HONORABLE MAYOR
AND COUNCIL MEMBERS

08/05/24
PAGE 13

PROCESSING OF VOUCHERS RESULTS IN CLAIMS AS FOLLOWS:

US BANK P CARD PAYMENTS	BUILDING REPAIRS/MAINTENANCE ACH PMT NO. - 80131973	648.75
US BANK P CARD PAYMENTS	CONTRACTUAL SERVICES ACH PMT NO. - 80131973	2,617.83
US BANK P CARD PAYMENTS	EQUIPMENT REPAIRS/MAINTENANCE ACH PMT NO. - 80131973	3,114.39
US BANK P CARD PAYMENTS	GENERAL REPAIRS/MAINT ACH PMT NO. - 80131973	772.70
US BANK P CARD PAYMENTS	ITEMS PURCHASED FOR INVENTORY ACH PMT NO. - 80131973	2,697.85
US BANK P CARD PAYMENTS	IT/DATA SERVICES ACH PMT NO. - 80131973	37.90
US BANK P CARD PAYMENTS	MINOR EQUIPMENT ACH PMT NO. - 80131973	163.70
US BANK P CARD PAYMENTS	OFFICE SUPPLIES ACH PMT NO. - 80131973	423.27
US BANK P CARD PAYMENTS	OPERATING SUPPLIES ACH PMT NO. - 80131973	10,700.84
US BANK P CARD PAYMENTS	OTHER MISC CHARGES ACH PMT NO. - 80131973	8.93
US BANK P CARD PAYMENTS	PRINTING/BINDING/REPRO ACH PMT NO. - 80131973	518.14
US BANK P CARD PAYMENTS	PROFESSIONAL SERVICES ACH PMT NO. - 80131973	318.91
US BANK P CARD PAYMENTS	RECREATIONAL SUPPLIES ACH PMT NO. - 80131973	2,514.79
US BANK P CARD PAYMENTS	REGISTRATION/SCHOOLING ACH PMT NO. - 80131973	605.15
US BANK P CARD PAYMENTS	REPAIRS/MAINTENANCE	

	ACH PMT NO. - 80131973	2,664.83
US BANK P CARD PAYMENTS	SMALL TOOLS	
	ACH PMT NO. - 80131973	594.22
WA STATE DEPT OF REVENUE	CONTRACTUAL SERVICES	
	-	9.90
WA STATE DEPT OF REVENUE	EQUIPMENT REPAIRS/MAINTENANCE	
	-	106.70
WA STATE DEPT OF REVENUE	ITEMS PURCHASED FOR INVENTORY	
	-	1.89
WA STATE DEPT OF REVENUE	OPERATING SUPPLIES	
	-	148.89

HONORABLE MAYOR
AND COUNCIL MEMBERS

08/05/24
PAGE 14

PROCESSING OF VOUCHERS RESULTS IN CLAIMS AS FOLLOWS:

WA STATE DEPT OF REVENUE	RECREATIONAL SUPPLIES	
	-	114.70
WA STATE DEPT OF REVENUE	REPAIRS/MAINTENANCE	
	-	105.36
TOTAL FOR 1400 - PARKS AND RECREATION FUND		----- 32,554.67

1425 - AMERICAN RESCUE PLAN

KEY CODE MEDIA INC	TV'S/AUDIO VISUAL EQUIPMENT	
ABS WASHINGTON	ACH PMT NO. - 80131954	48,983.84
PRO MECHANICAL SERVICES INC	OTHER IMPROVEMENTS	
	ACH PMT NO. - 80131963	440.15
STANTEC CONSULTING SERVICES INC	CONTRACTUAL SERVICES	
	ACH PMT NO. - 80132095	7,436.25
US BANK P CARD PAYMENTS	MISC REPAIRS/MAINTENANCE	
	ACH PMT NO. - 80131973	1,129.15
US BANK P CARD PAYMENTS	OTHER IMPROVEMENTS	
	ACH PMT NO. - 80131973	1,052.07
VOLT MANAGEMENT CORP	CONTRACTUAL SERVICES	
DBA VOLT WORKFORCE SOLUTIONS	ACH PMT NO. - 80132063	21,957.30
TOTAL FOR 1425 - AMERICAN RESCUE PLAN		----- 80,998.76

1440 - FIRE GRANTS MISCELLANEOUS

US BANK P CARD PAYMENTS	NON-TRAVEL MEALS/LGHT RFRSHMT	
	ACH PMT NO. - 80131973	23.75
US BANK P CARD PAYMENTS	PROMOTIONAL SUPPLIES	
	ACH PMT NO. - 80131973	1,269.94
WA STATE DEPT OF NATURAL RESOURCES	CONTRACTUAL SERVICES	
	CHECK NO. - 00604655	26,934.37
WA STATE DEPT OF NATURAL RESOURCES	GRANT CASH PASS THRU ACCOUNT	
	CHECK NO. - 00604655	26,934.37-

TOTAL FOR 1440 - FIRE GRANTS MISCELLANEOUS		----- 1,293.69
1460 - PARKING METER REVENUE FUND		

LOOMIS ARMORED US INC	CONTRACTUAL SERVICES ACH PMT NO. - 80132002	2,250.83
US BANK P CARD PAYMENTS	LEGAL SERVICES ACH PMT NO. - 80131973	18.45
HONORABLE MAYOR AND COUNCIL MEMBERS		08/05/24 PAGE 15
PROCESSING OF VOUCHERS RESULTS IN CLAIMS AS FOLLOWS:		
US BANK P CARD PAYMENTS	OFFICE SUPPLIES ACH PMT NO. - 80131973	329.40
US BANK P CARD PAYMENTS	OPERATING SUPPLIES ACH PMT NO. - 80131973	24.57
US BANK P CARD PAYMENTS	PRINTING/BINDING/REPRO ACH PMT NO. - 80131973	646.11
US BANK P CARD PAYMENTS	REPAIR & MAINTENANCE SUPPLIES ACH PMT NO. - 80131973	23.56
TOTAL FOR 1460 - PARKING METER REVENUE FUND		----- 3,292.92
1500 - PATHS AND TRAILS RESERVE FUND		

ABLE CLEAN-UP TECHNOLOGIES INC	CONTRACTUAL SERVICES ACH PMT NO. - 80132072	1,220.00
TOTAL FOR 1500 - PATHS AND TRAILS RESERVE FUND		----- 1,220.00
1560 - FORFEITURES & CONTRIBUTION FND		

ASCENDENT TECHNOLOGY GROUP INC	TV'S/AUDIO VISUAL EQUIPMENT CHECK NO. - 00604667	10,939.76
GALLS LLC	PROTECTIVE GEAR/CLOTHING CREDIT CARD PMT NO. - 70000471	6,211.82
US BANK P CARD PAYMENTS	OPERATING SUPPLIES ACH PMT NO. - 80131973	200.55
WA STATE DEPT OF REVENUE	TV'S/AUDIO VISUAL EQUIPMENT -	984.58
TOTAL FOR 1560 - FORFEITURES & CONTRIBUTION FND		----- 18,336.71
1620 - PUBLIC SAFETY & JUDICIAL GRANT		

SAFEWARE INC	TV'S/AUDIO VISUAL EQUIPMENT CHECK NO. - 00604677	52,501.62
TOTAL FOR 1620 - PUBLIC SAFETY & JUDICIAL GRANT		----- 52,501.62

1640 - COMMUNICATIONS BLDG M&O FUND

CAMTEK INC	BUILDING REPAIRS/MAINTENANCE ACH PMT NO. - 80131873	218.00
FASTENAL CO	OPERATING SUPPLIES ACH PMT NO. - 80131996	1,047.95

HONORABLE MAYOR
AND COUNCIL MEMBERS

08/05/24
PAGE 16

PROCESSING OF VOUCHERS RESULTS IN CLAIMS AS FOLLOWS:

US BANK P CARD PAYMENTS	BUILDING REPAIRS/MAINTENANCE ACH PMT NO. - 80131973	563.53
-------------------------	--	--------

TOTAL FOR 1640 - COMMUNICATIONS BLDG M&O FUND		1,829.48
---	--	----------

1910 - CRIMINAL JUSTICE ASSISTANCE FD

DS SERVICES OF AMERICA INC DBA CRYSTAL SPRINGS	OFFICE SUPPLIES CHECK NO. - 00604616	45.10
JRM ENTERPRISES INC DBA PROFESSIONAL LANGUAGE	INTERPRETER COSTS ACH PMT NO. - 80132041	5,275.00

TOTAL FOR 1910 - CRIMINAL JUSTICE ASSISTANCE FD		5,320.10
---	--	----------

1940 - CHANNEL FIVE EQUIPMENT RESERVE

US BANK P CARD PAYMENTS	MINOR EQUIPMENT ACH PMT NO. - 80131973	1,506.46
-------------------------	---	----------

TOTAL FOR 1940 - CHANNEL FIVE EQUIPMENT RESERVE		1,506.46
---	--	----------

1970 - FIRE/EMS FUND

ALASKA RUBBER GROUP INC DBA ARG INDUSTRIAL	VEHICLE REPAIR & MAINT SUPPLY CREDIT CARD PMT NO. - 70000475	180.53
ALSCO DIVISION OF ALSCO INC	LAUNDRY/JANITORIAL SERVICES ACH PMT NO. - 80132018	139.57
AT&T MOBILITY	CELL PHONE CHECK NO. - 00604668	5,900.00
AT&T MOBILITY	IT/DATA SERVICES CHECK NO. - 00604668	6,626.98
A-L COMPRESSED GASES INC 4230 E TRENT AVE	PERMIT REFUNDS PAYABLE CHECK NO. - 00604737	76.00
BENJAMIN M PRICE	REGISTRATION/SCHOOLING ACH PMT NO. - 80132069	778.00
BLACK REALTY MANAGEMENT 801 W RIVERSIDE AVE	PERMIT REFUNDS PAYABLE CHECK NO. - 00604738	38.00
COLEMAN OIL COMPANY LLC	MOTOR FUEL-OUTSIDE VENDOR ACH PMT NO. - 80131987	6,786.74
COMCAST	IT/DATA SERVICES	

CHECK NO. - 00604652 289.63

COPIERS NORTHWEST INC OPERATING RENTALS/LEASES
ACH PMT NO. - 80131990 3,005.39

HONORABLE MAYOR
AND COUNCIL MEMBERS

08/05/24
PAGE 17

PROCESSING OF VOUCHERS RESULTS IN CLAIMS AS FOLLOWS:

DELL MARKETING LP %DELL USA LP	COMPUTERS ACH PMT NO. - 80131993	4,743.84
FASTENAL CO	OPERATING SUPPLIES ACH PMT NO. - 80131996	1,445.15
FASTENAL CO	REPAIR & MAINTENANCE SUPPLIES ACH PMT NO. - 80131996	361.15
FASTENAL CO	VEHICLE REPAIR & MAINT SUPPLY ACH PMT NO. - 80131996	555.74
FEDERAL EXPRESS CORP/DBA FEDEX	POSTAGE ACH PMT NO. - 80132034	25.53
GALLS LLC	CLOTHING CREDIT CARD PMT NO. - 70000471	993.02
GALLS LLC	CLOTHING ALTERATIONS & REPAIRS CREDIT CARD PMT NO. - 70000471	141.35
GOODALE & BARBIERI 818 W RIVERSIDE AVE	PERMIT REFUNDS PAYABLE CHECK NO. - 00604739	202.00
HUGHES FIRE EQUIPMENT INC	VEHICLE REPAIR & MAINT SUPPLY CREDIT CARD PMT NO. - 70000473	5,002.05
JORDAN JOHNSON	REGISTRATION/SCHOOLING ACH PMT NO. - 80132016	408.00
JUSTIN C FREEMAN	OTHER TRANSPORTATION EXPENSES CHECK NO. - 00604754	140.92
KEVIN HAUGHTON	OTHER TRANSPORTATION EXPENSES ACH PMT NO. - 80132068	436.84
KEVIN HAUGHTON	PER DIEM ACH PMT NO. - 80132068	202.50
KIEMLE & HAGOOD 601 W MAIN AVE	PERMIT REFUNDS PAYABLE CHECK NO. - 00604740	202.00
L N CURTIS & SONS	CLOTHING ALTERATIONS & REPAIRS ACH PMT NO. - 80132029	132.12
LIFE ASSIST INC	SAFETY SUPPLIES ACH PMT NO. - 80131955	212.01
LT REAL ESTATE 902 W GARLAND	PERMIT REFUNDS PAYABLE CHECK NO. - 00604741	44.00
MICHAEL VAUGHAN	OTHER TRANSPORTATION EXPENSES ACH PMT NO. - 80132070	609.70
MICHAEL VAUGHAN	PER DIEM ACH PMT NO. - 80132070	86.50
NORCO INC	SAFETY SUPPLIES CREDIT CARD PMT NO. - 70000477	263.35

PROCESSING OF VOUCHERS RESULTS IN CLAIMS AS FOLLOWS:

OVERHEAD DOOR CORPORATION DBA WAYNE DALTON SALES &	BUILDING REPAIRS/MAINTENANCE CHECK NO. - 00604625	588.60
OVERHEAD DOOR CORPORATION DBA WAYNE DALTON SALES &	REPAIR & MAINTENANCE SUPPLIES CHECK NO. - 00604625	687.25
PACIFIC NW EMERGENCY EQUIPMENT dba GENERAL FIRE APPARATUS	VEHICLE REPAIR & MAINT SUPPLY ACH PMT NO. - 80132049	93.52
PRO BUILDERS GENERAL CONTRACTORS	PERMIT REFUNDS PAYABLE CHECK NO. - 00604742	38.00
SEAWESTERN FIRE APPARATUS & EQUIPMENT/SEAWESTERN INC	EQUIPMENT REPAIRS/MAINTENANCE ACH PMT NO. - 80131966	294.30
SEAWESTERN FIRE APPARATUS & EQUIPMENT/SEAWESTERN INC	REPAIR & MAINTENANCE SUPPLIES ACH PMT NO. - 80131966	187.66
SITEONE LANDSCAPE SUPPLY LLC	REPAIR & MAINTENANCE SUPPLIES CREDIT CARD PMT NO. - 70000478	67.52
SPOKANE EMERGENCY PHYSICIANS INC	CONTRACTUAL SERVICES ACH PMT NO. - 80131919	8,265.98
STERICYCLE INC DBA SHRED-IT	HAZARDOUS WASTE DISPOSAL ACH PMT NO. - 80132012	712.30
US BANK P CARD PAYMENTS	BANK FEES ACH PMT NO. - 80131973	65.20
US BANK P CARD PAYMENTS	CELL PHONE ACH PMT NO. - 80131973	554.35
US BANK P CARD PAYMENTS	MINOR EQUIPMENT ACH PMT NO. - 80131973	3,647.91
US BANK P CARD PAYMENTS	MOTOR FUEL-OUTSIDE VENDOR ACH PMT NO. - 80131973	347.36
US BANK P CARD PAYMENTS	NON-TRAVEL MEALS/LGHT RFRSHMT ACH PMT NO. - 80131973	1.19
US BANK P CARD PAYMENTS	OFFICE SUPPLIES ACH PMT NO. - 80131973	985.13
US BANK P CARD PAYMENTS	OPERATING SUPPLIES ACH PMT NO. - 80131973	13,758.62
US BANK P CARD PAYMENTS	OTH DUES/SUBSCRIPTNS/MEMBERSHP ACH PMT NO. - 80131973	805.17
US BANK P CARD PAYMENTS	POSTAGE ACH PMT NO. - 80131973	88.32
US BANK P CARD PAYMENTS	PRINTING/BINDING/REPRO ACH PMT NO. - 80131973	75.12
US BANK P CARD PAYMENTS	PROMOTIONAL SUPPLIES ACH PMT NO. - 80131973	63.49

PROCESSING OF VOUCHERS RESULTS IN CLAIMS AS FOLLOWS:

US BANK P CARD PAYMENTS	PUBLICATIONS ACH PMT NO. - 80131973	129.99
US BANK P CARD PAYMENTS	REPAIR & MAINTENANCE SUPPLIES ACH PMT NO. - 80131973	1,587.84
US BANK P CARD PAYMENTS	SOFTWARE MAINTENANCE ACH PMT NO. - 80131973	11.00
US BANK P CARD PAYMENTS	VEHICLE REPAIR & MAINT SUPPLY ACH PMT NO. - 80131973	2,016.32
WA STATE DEPT OF NATURAL RESOURCES	CONTRACTUAL SERVICES CHECK NO. - 00604655	6,733.59
WA STATE DEPT OF REVENUE	MINOR EQUIPMENT -	217.71
WA STATE DEPT OF REVENUE	OPERATING SUPPLIES -	232.78
WA STATE DEPT OF REVENUE	REPAIR & MAINTENANCE SUPPLIES -	69.56
WA STATE DEPT OF REVENUE	VEHICLE REPAIR & MAINT SUPPLY -	3.09
TOTAL FOR 1970 - FIRE/EMS FUND		82,357.48

3200 - ARTERIAL STREET FUND

BUDINGER & ASSOCIATES INC	CONSTRUCTION OF FIXED ASSETS ACH PMT NO. - 80132020	2,117.18
BUDINGER & ASSOCIATES INC	CONTRACTUAL SERVICES ACH PMT NO. - 80132020	588.58
CPM DEVELOPMENT CORP DBA INLAND ASPHALT COMPANY	CONSTRUCTION OF FIXED ASSETS ACH PMT NO. - 80131953	1,843,250.11
HAMILTON CONSTRUCTION CO	CONSTRUCTION OF FIXED ASSETS ACH PMT NO. - 80131951	557,313.35
KPFF CONSULTING ENGINEERS	CONSTRUCTION OF FIXED ASSETS ACH PMT NO. - 80132088	23,133.06
PARAMETRIX INC	CONSTRUCTION OF FIXED ASSETS ACH PMT NO. - 80131909	3,392.50
SHAMROCK PAVING CO/DIV OF MURPHY BROS INC	CONTRACTUAL SERVICES ACH PMT NO. - 80131967	854,446.40
TOTAL FOR 3200 - ARTERIAL STREET FUND		3,284,241.18

4100 - WATER DIVISION

HONORABLE MAYOR
AND COUNCIL MEMBERS

08/05/24
PAGE 20

PROCESSING OF VOUCHERS RESULTS IN CLAIMS AS FOLLOWS:

ACTION MATERIALS	REPAIR & MAINTENANCE SUPPLIES
------------------	-------------------------------

	ACH PMT NO. - 80131979	1,383.31
AMERICAN AVK COMPANY	INVENTORY PURCHASES FOR WATER ACH PMT NO. - 80131982	21,949.82
ANATEK LABS INC	CONTRACTUAL SERVICES CREDIT CARD PMT NO. - 70000452	40.00
ANGELA GRUNTE 4004 E WINDSONG AVE	REFUNDS CHECK NO. - 00604725	110.87
AVISTA UTILITIES	PUBLIC UTILITY SERVICE ACH PMT NO. - 80131985	67.48
BRANOM OPERATING COMPANY LLC BRANOM INSTRUMENT COMPANY	REPAIR & MAINTENANCE SUPPLIES CREDIT CARD PMT NO. - 70000470	1,766.16
CORE & MAIN LP	CONSTRUCTION OF FIXED ASSETS ACH PMT NO. - 80131991	6,771.62
CORE & MAIN LP	INVENTORY PURCHASES FOR WATER ACH PMT NO. - 80131991	25,553.97
ESTATE OF HARLAN D DOUGLASS 815 E ROSEWOOD AVE	REFUNDS CHECK NO. - 00604736	22,436.59
GEOENGINEERS INC	CONSTRUCTION OF FIXED ASSETS ACH PMT NO. - 80131891	289,650.00
GEOENGINEERS INC	CONTRACTUAL SERVICES ACH PMT NO. - 80131891	689.00
GORLEY LOGISTICS LLC dba FIKES NORTHWEST	CONTRACTUAL SERVICES ACH PMT NO. - 80131997	49.90
H D FOWLER COMPANY	CONSTRUCTION OF FIXED ASSETS ACH PMT NO. - 80132083	6,457.80
H D FOWLER COMPANY	INVENTORY PURCHASES FOR WATER ACH PMT NO. - 80131999	1,438.75
H D FOWLER COMPANY	POWER TOOLS/EQUIPMENT ACH PMT NO. - 80131999	118.41
H D FOWLER COMPANY	REPAIR & MAINTENANCE SUPPLIES ACH PMT NO. - 80131999	1,315.70
HASKINS STEEL CO INC	REPAIR & MAINTENANCE SUPPLIES ACH PMT NO. - 80132084	352.48
INLAND POWER & LIGHT CO	UTILITY LIGHT/POWER SERVICE ACH PMT NO. - 80132000	793.01
K & B EXCAVATING INC PO BOX 2437	REFUNDS CHECK NO. - 00604727	1,500.00
KAISER FOUNDATION HEALTH OF WASHINGTON	MEDICAL SERVICES CHECK NO. - 00604673	1,248.00

HONORABLE MAYOR
AND COUNCIL MEMBERS

08/05/24
PAGE 21

PROCESSING OF VOUCHERS RESULTS IN CLAIMS AS FOLLOWS:

KEITH AND CINDY GAUTHIER 11280 W MEADOWVIEW LN	REFUNDS CHECK NO. - 00604726	208.45
MCGARD LLC	INVENTORY PURCHASES FOR WATER ACH PMT NO. - 80132090	98,196.16

MCMILLEN INC	CONSTRUCTION OF FIXED ASSETS ACH PMT NO. - 80131901	19,090.00
MOTION INDUSTRIES INC DBA HYDRAULIC SUPPLY COMPANY	OPERATING SUPPLIES ACH PMT NO. - 80132004	3,965.44
NORTHEAST PUBLIC DEVELOPMENT AUTHORITY	OTHER MISC CHARGES ACH PMT NO. - 80132091	2,840.57
OXARC INC	OPERATING SUPPLIES CREDIT CARD PMT NO. - 70000474	16,861.06
RAY TURF FARMS INC	REPAIR & MAINTENANCE SUPPLIES ACH PMT NO. - 80132009	33.54
SILAS & HEIDI PRATT 319 W WAVERLY PLACE	REFUNDS CHECK NO. - 00604728	31.17
US BANK P CARD PAYMENTS	CHEMICAL/LAB SUPPLIES ACH PMT NO. - 80131973	533.05
US BANK P CARD PAYMENTS	COMPL MAINTENANCE EXPENSE WO ACH PMT NO. - 80131973	49.00
US BANK P CARD PAYMENTS	EQUIPMENT REPAIRS/MAINTENANCE ACH PMT NO. - 80131973	558.60
US BANK P CARD PAYMENTS	INVENTORY PURCHASES FOR WATER ACH PMT NO. - 80131973	1,406.45
US BANK P CARD PAYMENTS	MINOR EQUIPMENT ACH PMT NO. - 80131973	4,178.61
US BANK P CARD PAYMENTS	OFFICE SUPPLIES ACH PMT NO. - 80131973	781.73
US BANK P CARD PAYMENTS	OPERATING SUPPLIES ACH PMT NO. - 80131973	5,905.44
US BANK P CARD PAYMENTS	PERMITS/OTHER FEES ACH PMT NO. - 80131973	163.05
US BANK P CARD PAYMENTS	PRINTING/BINDING/REPRO ACH PMT NO. - 80131973	524.20
US BANK P CARD PAYMENTS	REGISTRATION/SCHOOLING ACH PMT NO. - 80131973	1,290.00
US BANK P CARD PAYMENTS	REPAIR & MAINTENANCE SUPPLIES ACH PMT NO. - 80131973	31,052.37
US BANK P CARD PAYMENTS	REPAIRS/MAINTENANCE ACH PMT NO. - 80131973	359.26

HONORABLE MAYOR
AND COUNCIL MEMBERS

08/05/24
PAGE 22

PROCESSING OF VOUCHERS RESULTS IN CLAIMS AS FOLLOWS:

WA STATE DEPT OF REVENUE	INVENTORY PURCHASES FOR WATER -	10,813.13
WA STATE DEPT OF REVENUE	OPERATING SUPPLIES -	223.26
WA STATE DEPT OF REVENUE	REPAIR & MAINTENANCE SUPPLIES -	113.22

TOTAL FOR 4100 - WATER DIVISION

582,870.63

4250 - INTEGRATED CAPITAL MANAGEMENT

BUDINGER & ASSOCIATES INC	CONSTRUCTION OF FIXED ASSETS ACH PMT NO. - 80132020	7,363.62
DELL MARKETING LP %DELL USA LP	SOFTWARE (NONCAPITALIZED) ACH PMT NO. - 80131993	110.90
KPFF CONSULTING ENGINEERS	CONSTRUCTION OF FIXED ASSETS ACH PMT NO. - 80132088	38,999.00
NORTHWEST GRADING INC	CONSTRUCTION OF FIXED ASSETS ACH PMT NO. - 80131962	255,235.51
OAC SERVICES INC	CONSTRUCTION OF FIXED ASSETS ACH PMT NO. - 80132005	12,554.58
PARAMETRIX INC	CONSTRUCTION OF FIXED ASSETS ACH PMT NO. - 80132006	14,105.00
SHI CORP	SOFTWARE (NONCAPITALIZED) ACH PMT NO. - 80132054	70.73
US BANK P CARD PAYMENTS	OFFICE FURNITURE (NON CAPITAL) ACH PMT NO. - 80131973	289.93

TOTAL FOR 4250 - INTEGRATED CAPITAL MANAGEMENT

328,729.27

4300 - SEWER FUND

ESTATE OF HARLAN D DOUGLASS 815 E ROSEWOOD AVE	REFUNDS CHECK NO. - 00604736	36,770.71
---	---------------------------------	-----------

TOTAL FOR 4300 - SEWER FUND

36,770.71

4310 - SEWER MAINTENANCE DIVISION

ACTION MATERIALS	REPAIR & MAINTENANCE SUPPLIES ACH PMT NO. - 80131979	28.28
COLEMAN OIL COMPANY LLC	MOTOR FUEL-OUTSIDE VENDOR ACH PMT NO. - 80131987	6,299.00

HONORABLE MAYOR
AND COUNCIL MEMBERS

08/05/24
PAGE 23

PROCESSING OF VOUCHERS RESULTS IN CLAIMS AS FOLLOWS:

CONSOLIDATED ELECTRICAL DISTRIBUTORS INC	REPAIR & MAINTENANCE SUPPLIES ACH PMT NO. - 80131988	8,050.19
CONTECH ENGINEERED SOLUTIONS LLC	REPAIR & MAINTENANCE SUPPLIES ACH PMT NO. - 80131989	5,395.50
COPIERS NORTHWEST INC	OPERATING RENTALS/LEASES ACH PMT NO. - 80132076	1,203.77
CUESTA SPRINGS ICE COMPANY OF IDAHO LLC	REPAIR & MAINTENANCE SUPPLIES ACH PMT NO. - 80132077	202.74
DELL MARKETING LP	COMPUTERS	

%DELL USA LP	ACH PMT NO. - 80132030	569.64
DELL MARKETING LP	MINOR EQUIPMENT	
%DELL USA LP	ACH PMT NO. - 80131993	2,212.06
GORDON TRUCK CENTERS INC DBA PACIFIC TRUCK CENTERS	VEHICLES CREDIT CARD PMT NO. - 70000472	160,162.99
KAISER FOUNDATION HEALTH OF WASHINGTON	MEDICAL SERVICES CHECK NO. - 00604673	240.00
MICHAEL D LOWDON	PERMITS/OTHER FEES CHECK NO. - 00604743	136.00
PARAMETRIX INC	CONTRACTUAL SERVICES ACH PMT NO. - 80131909	6,805.00
US BANK P CARD PAYMENTS	ALARM/SECURITY SERVICES ACH PMT NO. - 80131973	470.88
US BANK P CARD PAYMENTS	EQUIPMENT REPAIRS/MAINTENANCE ACH PMT NO. - 80131973	1,587.98
US BANK P CARD PAYMENTS	MINOR EQUIPMENT ACH PMT NO. - 80131973	602.48
US BANK P CARD PAYMENTS	MISC REPAIRS/MAINTENANCE ACH PMT NO. - 80131973	490.50
US BANK P CARD PAYMENTS	OFFICE SUPPLIES ACH PMT NO. - 80131973	391.80
US BANK P CARD PAYMENTS	OPERATING SUPPLIES ACH PMT NO. - 80131973	4,237.31
US BANK P CARD PAYMENTS	PARKING/TOLLS (LOCAL) ACH PMT NO. - 80131973	48.50
US BANK P CARD PAYMENTS	REGISTRATION/SCHOOLING ACH PMT NO. - 80131973	2,345.00
US BANK P CARD PAYMENTS	REPAIR & MAINTENANCE SUPPLIES ACH PMT NO. - 80131973	459.10
US BANK P CARD PAYMENTS	SAFETY SUPPLIES ACH PMT NO. - 80131973	3,188.84

HONORABLE MAYOR
AND COUNCIL MEMBERS

08/05/24
PAGE 24

PROCESSING OF VOUCHERS RESULTS IN CLAIMS AS FOLLOWS:

US BANK P CARD PAYMENTS	SMALL TOOLS ACH PMT NO. - 80131973	1,768.81
WA STATE DEPT OF REVENUE	OPERATING SUPPLIES -	4.40
WA STATE DEPT OF REVENUE	REPAIR & MAINTENANCE SUPPLIES -	12.47
TOTAL FOR 4310 - SEWER MAINTENANCE DIVISION		206,913.24

4320 - RIVERSIDE PARK RECLAMATION FAC

AVISTA UTILITIES	UTILITY LIGHT/POWER SERVICE ACH PMT NO. - 80131985	284.76
------------------	---	--------

AVISTA UTILITIES	UTILITY NATURAL GAS ACH PMT NO. - 80131985	17.50
CENTER FOR SUSTAINABLE INFRASTRUCTURE	REGISTRATION/SCHOOLING ACH PMT NO. - 80131875	11,600.00
CENTURYLINK	TELEPHONE CHECK NO. - 00604752	64.99
COMCAST	IT/DATA SERVICES CHECK NO. - 00604753	214.91
HASA INC	CHEMICAL/LAB SUPPLIES ACH PMT NO. - 80131893	15,571.57
KAISER FOUNDATION HEALTH OF WASHINGTON	MEDICAL SERVICES CHECK NO. - 00604673	240.00
US BANK P CARD PAYMENTS	EQUIPMENT REPAIRS/MAINTENANCE ACH PMT NO. - 80131973	624.57
US BANK P CARD PAYMENTS	LUBRICANTS ACH PMT NO. - 80131973	38.71
US BANK P CARD PAYMENTS	MINOR EQUIPMENT ACH PMT NO. - 80131973	291.09
US BANK P CARD PAYMENTS	MINOR SAFETY EQUIPMENT ACH PMT NO. - 80131973	817.93
US BANK P CARD PAYMENTS	OFFICE SUPPLIES ACH PMT NO. - 80131973	181.01
US BANK P CARD PAYMENTS	OPERATING SUPPLIES ACH PMT NO. - 80131973	18,199.12
US BANK P CARD PAYMENTS	REGISTRATION/SCHOOLING ACH PMT NO. - 80131973	487.99
US BANK P CARD PAYMENTS	REPAIR & MAINTENANCE SUPPLIES ACH PMT NO. - 80131973	805.32

HONORABLE MAYOR
AND COUNCIL MEMBERS

08/05/24
PAGE 25

PROCESSING OF VOUCHERS RESULTS IN CLAIMS AS FOLLOWS:

US BANK P CARD PAYMENTS	SAFETY SUPPLIES ACH PMT NO. - 80131973	162.40
US BANK P CARD PAYMENTS	SMALL TOOLS ACH PMT NO. - 80131973	112.87
WA STATE DEPT OF REVENUE	OPERATING SUPPLIES -	45.19

TOTAL FOR 4320 - RIVERSIDE PARK RECLAMATION FAC -----
49,759.93

4330 - STORMWATER

AVISTA UTILITIES	UTILITY LIGHT/POWER SERVICE ACH PMT NO. - 80132073	404.14
BUDINGER & ASSOCIATES INC	CONTRACTUAL SERVICES ACH PMT NO. - 80131872	14,778.00

CENTURYLINK	TELEPHONE	
	CHECK NO. - 00604752	86.54
KAISER FOUNDATION HEALTH OF WASHINGTON	MEDICAL SERVICES	
	CHECK NO. - 00604673	240.00
US BANK P CARD PAYMENTS	REPAIR & MAINTENANCE SUPPLIES	
	ACH PMT NO. - 80131973	1,568.80
TOTAL FOR 4330 - STORMWATER		17,077.48

4480 - SOLID WASTE FUND

ANDREW MASSIE	REFUNDS	
2310 PASQUA TRAIL	CHECK NO. - 00604724	214.88
TOTAL FOR 4480 - SOLID WASTE FUND		214.88

4490 - SOLID WASTE DISPOSAL

COPIERS NORTHWEST INC	OPERATING RENTALS/LEASES	
	ACH PMT NO. - 80131990	176.65
FINLEY BUTTES LIMITED PARTNERSHIP DBA FINLEY BUTTES	CONTRACTUAL SERVICES	
	ACH PMT NO. - 80131887	211,163.05
HYDRAULICS PLUS INC	EQUIPMENT REPAIRS/MAINTENANCE	
	CREDIT CARD PMT NO. - 70000456	1,024.21
KAISER FOUNDATION HEALTH OF WASHINGTON	MEDICAL SERVICES	
	CHECK NO. - 00604618	9,606.96
LOOMIS ARMORED US INC	CONTRACTUAL SERVICES	
	ACH PMT NO. - 80132002	1,321.32

HONORABLE MAYOR
AND COUNCIL MEMBERS

08/05/24
PAGE 26

PROCESSING OF VOUCHERS RESULTS IN CLAIMS AS FOLLOWS:

LSB CONSULTING ENGINEERS PLLC	PROFESSIONAL SERVICES	
	ACH PMT NO. - 80131898	10,370.30
MATT HOUSTON dba SKUNKWORKS	CONTRACTUAL SERVICES	
	ACH PMT NO. - 80131914	650.00
OIL RE-REFINING CO INC	HAZARDOUS WASTE DISPOSAL	
	ACH PMT NO. - 80131907	367.50
SPOKANE REGIONAL HEALTH DIST	PERMITS/OTHER FEES	
	CHECK NO. - 00604757	19,805.58
TRANSPORT EQUIPMENT INC	VEHICLES	
	ACH PMT NO. - 80132061	116,507.94
UNITED RENTALS NW INC	OPERATING RENTALS/LEASES	
	CHECK NO. - 00604623	1,397.38
US BANK P CARD PAYMENTS	HAZARDOUS WASTE DISPOSAL	
	ACH PMT NO. - 80131973	165.00
US BANK P CARD PAYMENTS	MINOR EQUIPMENT	
	ACH PMT NO. - 80131973	4,117.55
US BANK P CARD PAYMENTS	OFFICE SUPPLIES	

	ACH PMT NO. - 80131973	644.90
US BANK P CARD PAYMENTS	OPERATING SUPPLIES ACH PMT NO. - 80131973	2,737.26
US BANK P CARD PAYMENTS	OTH DUES/SUBSCRIPTNS/MEMBERSHP ACH PMT NO. - 80131973	522.63
US BANK P CARD PAYMENTS	PERSONAL PROTECTIVE EQUIPMENT ACH PMT NO. - 80131973	91.60
US BANK P CARD PAYMENTS	POSTAGE ACH PMT NO. - 80131973	44.90
US BANK P CARD PAYMENTS	POWER TOOLS/EQUIPMENT ACH PMT NO. - 80131973	2,179.99
US BANK P CARD PAYMENTS	REGISTRATION/SCHOOLING ACH PMT NO. - 80131973	52.00
US BANK P CARD PAYMENTS	REPAIR & MAINTENANCE SUPPLIES ACH PMT NO. - 80131973	22,408.84
US BANK P CARD PAYMENTS	SMALL TOOLS ACH PMT NO. - 80131973	1,016.98
WA STATE DEPT OF REVENUE	PERSONAL PROTECTIVE EQUIPMENT -	8.24
WA STATE DEPT OF REVENUE	REPAIR & MAINTENANCE SUPPLIES -	609.88
WASTE MANAGEMENT OF WA DBA GRAHAM ROAD LANDFILL	CONTRACTUAL SERVICES CHECK NO. - 00604624	319,951.12

HONORABLE MAYOR
AND COUNCIL MEMBERS

08/05/24
PAGE 27

PROCESSING OF VOUCHERS RESULTS IN CLAIMS AS FOLLOWS:

WEAR-TEK INC	EQUIPMENT REPAIRS/MAINTENANCE ACH PMT NO. - 80131932	10,769.36
TOTAL FOR 4490 - SOLID WASTE DISPOSAL		737,711.14

4500 - SOLID WASTE COLLECTION

C & C YARD CARE	LANDSCAPE/GROUNDS MAINT ACH PMT NO. - 80131943	2,383.01
GWP HOLDINGS LLC DBA DOBBS PETERBILT	VEHICLES ACH PMT NO. - 80131994	558,477.79
KAISER FOUNDATION HEALTH OF WASHINGTON	MEDICAL SERVICES CHECK NO. - 00604673	233.00
SPOKANE PRO CARE INC	CONTRACTUAL SERVICES ACH PMT NO. - 80131971	432.73
US BANK P CARD PAYMENTS	MEDICAL SERVICES ACH PMT NO. - 80131973	220.00
US BANK P CARD PAYMENTS	MISC REPAIRS/MAINTENANCE ACH PMT NO. - 80131973	381.50
US BANK P CARD PAYMENTS	OFFICE SUPPLIES ACH PMT NO. - 80131973	411.61

US BANK P CARD PAYMENTS	OPERATING SUPPLIES ACH PMT NO. - 80131973	1,731.76
US BANK P CARD PAYMENTS	PARKING/TOLLS (LOCAL) ACH PMT NO. - 80131973	4.00
US BANK P CARD PAYMENTS	PERMITS/OTHER FEES ACH PMT NO. - 80131973	5.00
US BANK P CARD PAYMENTS	SAFETY SUPPLIES ACH PMT NO. - 80131973	341.83
US BANK P CARD PAYMENTS	SMALL TOOLS ACH PMT NO. - 80131973	299.29
WM RECYCLE AMERICA LLC	CONTRACTUAL SERVICES CHECK NO. - 00604656	168,203.51
WM RECYCLE AMERICA LLC	SALE OF RECYCLING MATERIALS CHECK NO. - 00604656	64,714.39-
TOTAL FOR 4500 - SOLID WASTE COLLECTION		668,410.64

4530 - SOLID WASTE LANDFILLS

COMCAST	IT/DATA SERVICES CHECK NO. - 00604652	207.91
---------	--	--------

HONORABLE MAYOR
AND COUNCIL MEMBERS

08/05/24
PAGE 28

PROCESSING OF VOUCHERS RESULTS IN CLAIMS AS FOLLOWS:

SPOKANE REGIONAL HEALTH DIST	PERMITS/OTHER FEES CHECK NO. - 00604756	1,020.66
US BANK P CARD PAYMENTS	CHEMICAL/LAB SUPPLIES ACH PMT NO. - 80131973	62.46
TOTAL FOR 4530 - SOLID WASTE LANDFILLS		1,291.03

4600 - GOLF FUND

KAISER FOUNDATION HEALTH OF WASHINGTON	BACKGROUND CHECKS CHECK NO. - 00604673	625.00
US BANK P CARD PAYMENTS	ADVERTISING ACH PMT NO. - 80131973	905.37
US BANK P CARD PAYMENTS	GENERAL REPAIRS/MAINT ACH PMT NO. - 80131973	74.83
US BANK P CARD PAYMENTS	OPERATING SUPPLIES ACH PMT NO. - 80131973	1,096.42
US BANK P CARD PAYMENTS	OTHER REPAIRS/MAINTENANCE ACH PMT NO. - 80131973	301.98
US BANK P CARD PAYMENTS	REPAIRS/MAINTENANCE ACH PMT NO. - 80131973	1,791.21
WA STATE DEPT OF REVENUE	OPERATING SUPPLIES -	20.04

TOTAL FOR 4600 - GOLF FUND

4,814.85

4700 - DEVELOPMENT SVCS CENTER

COOK SECURITY GROUP 9225 NE CASCADES PKWAY	PERMIT REFUNDS PAYABLE CHECK NO. - 00604621	30.00
COUGAR HEATING AND COOLING 212 EVANS ST	PERMIT REFUNDS PAYABLE CHECK NO. - 00604729	45.00
MADDOG CONTRACTING LLC 2139 W ALSEA AVE	PERMIT REFUNDS PAYABLE CHECK NO. - 00604731	60.00
MAINSTREAM ELECTRIC LLC 12822 E INDIANA AVE	PERMIT REFUNDS PAYABLE CHECK NO. - 00604732	15.00
MORSE WESTERN HOMES LLC 224 N CHIEF GARRY DR	PERMIT REFUNDS PAYABLE CHECK NO. - 00604733	650.00
NORTHWEST PERMIT INC 1026 SW 151ST ST	PERMIT REFUNDS PAYABLE CHECK NO. - 00604622	65.00
PATRIOT ELECTRIC AND LIGHTING 5512 N HAVANA	PERMIT REFUNDS PAYABLE CHECK NO. - 00604734	45.00

HONORABLE MAYOR
AND COUNCIL MEMBERS

08/05/24
PAGE 29

PROCESSING OF VOUCHERS RESULTS IN CLAIMS AS FOLLOWS:

STURM HEATING INC 1112 N NELSON ST	PERMIT REFUNDS PAYABLE CHECK NO. - 00604735	20.00
TRUEPOINT SOLUTIONS LLC	CONTRACTUAL SERVICES ACH PMT NO. - 80131926	1,737.34
US BANK P CARD PAYMENTS	BANK FEES ACH PMT NO. - 80131973	227.55
US BANK P CARD PAYMENTS	NON-TRAVEL MEALS/LGHT RFRSHMT ACH PMT NO. - 80131973	155.65
US BANK P CARD PAYMENTS	OFFICE SUPPLIES ACH PMT NO. - 80131973	217.77
US BANK P CARD PAYMENTS	OTH DUES/SUBSCRIPTNS/MEMBERSHP ACH PMT NO. - 80131973	526.98
US BANK P CARD PAYMENTS	PARKING/TOLLS (LOCAL) ACH PMT NO. - 80131973	506.45
US BANK P CARD PAYMENTS	PRINTING/BINDING/REPRO ACH PMT NO. - 80131973	126.71
US BANK P CARD PAYMENTS	PUBLICATIONS ACH PMT NO. - 80131973	1,592.37
US BANK P CARD PAYMENTS	REGISTRATION/SCHOOLING ACH PMT NO. - 80131973	2,800.00

TOTAL FOR 4700 - DEVELOPMENT SVCS CENTER

8,820.82

5100 - FLEET SERVICES FUND

AVISTA UTILITIES	UTILITY LIGHT/POWER SERVICE
------------------	-----------------------------

	ACH PMT NO. - 80132073	40.16
CINTAS CORPORATION	LAUNDRY/JANITORIAL SERVICES CREDIT CARD PMT NO. - 70000479	3,946.36
CINTAS CORPORATION NO 2	SAFETY SUPPLIES ACH PMT NO. - 80132074	552.34
CUMMINS INC DBA CUMMINS SALES & SERVICE	EQUIPMENT REPAIRS/MAINTENANCE ACH PMT NO. - 80131882	2,801.14
DELL MARKETING LP %DELL USA LP	COMPUTERS ACH PMT NO. - 80131993	404.82
EVERGREEN STATE TOWING LLC DBA SPOKANE VALLEY TOWING	TOWING EXPENSE CREDIT CARD PMT NO. - 70000453	1,192.46
LEVI MILLER	PERMITS/OTHER FEES CHECK NO. - 00604653	96.75
NOVUS AUTO GLASS	EQUIPMENT REPAIRS/MAINTENANCE ACH PMT NO. - 80131906	1,897.65

HONORABLE MAYOR
AND COUNCIL MEMBERS

08/05/24
PAGE 30

PROCESSING OF VOUCHERS RESULTS IN CLAIMS AS FOLLOWS:

US BANK P CARD PAYMENTS	EQUIPMENT REPAIRS/MAINTENANCE ACH PMT NO. - 80131973	588.48
US BANK P CARD PAYMENTS	MINOR EQUIPMENT ACH PMT NO. - 80131973	271.25
US BANK P CARD PAYMENTS	OFFICE SUPPLIES ACH PMT NO. - 80131973	84.60
US BANK P CARD PAYMENTS	OPERATING SUPPLIES ACH PMT NO. - 80131973	21.70
US BANK P CARD PAYMENTS	PERMITS/OTHER FEES ACH PMT NO. - 80131973	1,249.05
US BANK P CARD PAYMENTS	VEHICLE REPAIR & MAINT SUPPLY ACH PMT NO. - 80131973	3,147.10
VERIZON WIRELESS	CELL PHONE ACH PMT NO. - 80132096	510.39

TOTAL FOR 5100 - FLEET SERVICES FUND		16,804.25

5200 - PUBLIC WORKS AND UTILITIES

DEVRIES INFORMATION MANAGEMENT	CONTRACTUAL SERVICES ACH PMT NO. - 80132032	264.10
US BANK P CARD PAYMENTS	OFFICE SUPPLIES ACH PMT NO. - 80131973	235.36
US BANK P CARD PAYMENTS	PRINTING/BINDING/REPRO ACH PMT NO. - 80131973	931.38

TOTAL FOR 5200 - PUBLIC WORKS AND UTILITIES		1,430.84

5300 - IT FUND

COMCAST	IT/DATA SERVICES	
	CHECK NO. - 00604652	784.99
COMPUNET INC	HARDWARE MAINTENANCE	
LB 410802	ACH PMT NO. - 80132024	3,036.74
COMPUNET INC	MINOR EQUIPMENT	
LB 410802	ACH PMT NO. - 80132024	4,831.70
COMPUNET INC	SOFTWARE MAINTENANCE	
LB 410802	ACH PMT NO. - 80132024	146,333.77
DELL MARKETING LP	MINOR EQUIPMENT	
%DELL USA LP	ACH PMT NO. - 80132030	323.51
DEVRIES INFORMATION MANAGEMENT	CONTRACTUAL SERVICES	
	ACH PMT NO. - 80131883	17.10

HONORABLE MAYOR
AND COUNCIL MEMBERS

08/05/24
PAGE 31

PROCESSING OF VOUCHERS RESULTS IN CLAIMS AS FOLLOWS:

MYTHICS LLC	SOFTWARE MAINTENANCE	
	ACH PMT NO. - 80132046	1,195.22
NORTHWEST OPEN ACCESS NETWORK	TELEPHONE	
	ACH PMT NO. - 80131905	3,600.00
ORACLE AMERICA INC	SOFTWARE MAINTENANCE	
	ACH PMT NO. - 80131908	53,750.78
PICTOMETRY INTERNATIONAL CORP	SOFTWARE MAINTENANCE	
	ACH PMT NO. - 80132007	2,725.00
SHI CORP	IT/DATA SERVICES	
	ACH PMT NO. - 80132054	0.49
SHI CORP	SOFTWARE MAINTENANCE	
	ACH PMT NO. - 80132054	604.69
US BANK P CARD PAYMENTS	IT/DATA SERVICES	
	ACH PMT NO. - 80131973	964.77
US BANK P CARD PAYMENTS	MINOR EQUIPMENT	
	ACH PMT NO. - 80131973	261.34
US BANK P CARD PAYMENTS	OFFICE SUPPLIES	
	ACH PMT NO. - 80131973	117.29
US BANK P CARD PAYMENTS	SOFTWARE MAINTENANCE	
	ACH PMT NO. - 80131973	59.99
US BANK P CARD PAYMENTS	SOFTWARE (NONCAPITALIZED)	
	ACH PMT NO. - 80131973	383.58
VERTIV CORPORATION	HARDWARE MAINTENANCE	
	ACH PMT NO. - 80131929	3,276.27

TOTAL FOR 5300 - IT FUND

222,267.23

5310 - IT CAPITAL REPLACEMENT FUND

DELL MARKETING LP	COMPUTERS	
%DELL USA LP	ACH PMT NO. - 80132030	78,103.39

TOTAL FOR 5310 - IT CAPITAL REPLACEMENT FUND 78,103.39

5400 - REPROGRAPHICS FUND

COPIERS NORTHWEST INC	OPERATING RENTALS/LEASES ACH PMT NO. - 80131880	3,225.31
US BANK P CARD PAYMENTS	OPERATING SUPPLIES ACH PMT NO. - 80131973	915.18
US BANK P CARD PAYMENTS	SOFTWARE MAINTENANCE ACH PMT NO. - 80131973	228.90

HONORABLE MAYOR
AND COUNCIL MEMBERS

08/05/24
PAGE 32

PROCESSING OF VOUCHERS RESULTS IN CLAIMS AS FOLLOWS:

TOTAL FOR 5400 - REPROGRAPHICS FUND 4,369.39

5600 - ACCOUNTING SERVICES

PIA H CHRISTENSEN DBA CONTENT BY PIA	CONTRACTUAL SERVICES ACH PMT NO. - 80132067	1,100.00
US BANK P CARD PAYMENTS	OFFICE SUPPLIES ACH PMT NO. - 80131973	39.50
US BANK P CARD PAYMENTS	SOFTWARE (NONCAPITALIZED) ACH PMT NO. - 80131973	419.00
WA STATE DEPT OF REVENUE	SOFTWARE (NONCAPITALIZED) -	37.71

TOTAL FOR 5600 - ACCOUNTING SERVICES 1,596.21

5700 - MY SPOKANE

LANGUAGE SERVICES ASSOC INC	INTERPRETER COSTS ACH PMT NO. - 80131896	127.71
US BANK P CARD PAYMENTS	OFFICE SUPPLIES ACH PMT NO. - 80131973	27.77

TOTAL FOR 5700 - MY SPOKANE 155.48

5750 - OFFICE OF PERFORMANCE MGMT

INFINITE INNOVATIONS LLC	CONTRACTUAL SERVICES ACH PMT NO. - 80131895	6,245.30
VOLT MANAGEMENT CORP DBA VOLT WORKFORCE SOLUTIONS	CONTRACTUAL SERVICES ACH PMT NO. - 80131930	16,896.00

TOTAL FOR 5750 - OFFICE OF PERFORMANCE MGMT 23,141.30

5800 - RISK MANAGEMENT FUND

US BANK OR CITY TREASURER	INSURANCE CLAIMS	
---------------------------	------------------	--

LIABILITY CLAIMS ACH PMT NO. - 80132062 48,692.03

TOTAL FOR 5800 - RISK MANAGEMENT FUND 48,692.03

5820 - UNEMPLOYMENT COMPENSATION FUND

WA STATE EMPLOYMENT SECURITY INSURANCE CLAIMS
DEPARTMENT CHECK NO. - 00604679 55,761.93

HONORABLE MAYOR 08/05/24
AND COUNCIL MEMBERS PAGE 33

PROCESSING OF VOUCHERS RESULTS IN CLAIMS AS FOLLOWS:

TOTAL FOR 5820 - UNEMPLOYMENT COMPENSATION FUND 55,761.93

5830 - EMPLOYEES BENEFITS FUND

DELTA DENTAL OF WASHINGTON INSURANCE CLAIMS
ACH PMT NO. - 80132079 32,578.13

KAISER FOUNDATION HEALTH PLAN INSURANCE CLAIMS
OF WASHINGTON ACH PMT NO. - 80132087 149,828.48

LIFEWISE ASSURANCE CO INSURANCE PREMIUMS
ACH PMT NO. - 80132042 30,850.94

PREMERA BLUE CROSS OR INSURANCE CLAIMS
SPOKANE CITY TREASURER ACH PMT NO. - 80132008 790,283.56

UNITED STATES TREASURY ADVISORY TECHNICAL SERVICE
DEPT OF THE TREASURY CHECK NO. - 00604654 11,391.72

WAPAL FUND ADVISORY TECHNICAL SERVICE
WASHINGTON STATE HEALTH CARE ACH PMT NO. - 80131931 273.28

TOTAL FOR 5830 - EMPLOYEES BENEFITS FUND 1,015,206.11

5900 - FACILITIES MANAGEMENT FUND OPS

AVISTA CORPORATION UTILITY LIGHT/POWER SERVICE
ACH PMT NO. - 80132019 12,122.51

AVISTA CORPORATION UTILITY NATURAL GAS
ACH PMT NO. - 80132019 257.47

CENTURYLINK TELEPHONE
CHECK NO. - 00604669 396.62

CONTROL SOLUTIONS NW INC BUILDING REPAIRS/MAINTENANCE
ACH PMT NO. - 80131879 613.12

FOUR SEASONS SERVICES INC BUILDING REPAIRS/MAINTENANCE
DBA FOUR SEASONS LANDSCAPING ACH PMT NO. - 80132037 2,564.14

GOODALE & BARBIERI COMPANY OTHER CONTRACTUAL SERVICES
ACH PMT NO. - 80131998 3,781.54

GORLEY LOGISTICS LLC OPERATING SUPPLIES
dba FIKES NORTHWEST ACH PMT NO. - 80132035 349.30

HERRES BACKFLOW & CONSTRUCTION BUILDING REPAIRS/MAINTENANCE
LLC CHECK NO. - 00604617 750.00

MARTIN LUTHER KING JR FAMILY OUTREACH CENTER	PUBLIC UTILITY SERVICE ACH PMT NO. - 80131900	500.98
MARTIN LUTHER KING JR FAMILY OUTREACH CENTER	UTILITY LIGHT/POWER SERVICE ACH PMT NO. - 80131900	10.85

HONORABLE MAYOR
AND COUNCIL MEMBERS

08/05/24
PAGE 34

PROCESSING OF VOUCHERS RESULTS IN CLAIMS AS FOLLOWS:

MEGAMATION LLC	SUBSCRIPTION BASED IT ARNGMTS ACH PMT NO. - 80132045	595.00
STARPLEX CORP	ALARM/SECURITY SERVICES ACH PMT NO. - 80132011	30,218.32
US BANK P CARD PAYMENTS	MINOR EQUIPMENT ACH PMT NO. - 80131973	965.47
US BANK P CARD PAYMENTS	MISC SERVICES/CHARGES ACH PMT NO. - 80131973	12.36
US BANK P CARD PAYMENTS	OFFICE SUPPLIES ACH PMT NO. - 80131973	36.44
US BANK P CARD PAYMENTS	OPERATING RENTALS/LEASES ACH PMT NO. - 80131973	79.35
US BANK P CARD PAYMENTS	OPERATING SUPPLIES ACH PMT NO. - 80131973	378.55
US BANK P CARD PAYMENTS	PERMITS/OTHER FEES ACH PMT NO. - 80131973	76.00
US BANK P CARD PAYMENTS	REPAIR & MAINTENANCE SUPPLIES ACH PMT NO. - 80131973	12,718.20
US BANK P CARD PAYMENTS	SOFTWARE (NONCAPITALIZED) ACH PMT NO. - 80131973	12.81
WA STATE DEPT OF REVENUE	REPAIR & MAINTENANCE SUPPLIES -	18.63
WA STATE DEPT OF REVENUE	SUBSCRIPTION BASED IT ARNGMTS -	53.55

TOTAL FOR 5900 - FACILITIES MANAGEMENT FUND OPS ----- 66,511.21

5902 - PROPERTY ACQUISITION POLICE

CLARY LONGVIEW LLC DBA BUD CLARY FORD/HYUNDAI	VEHICLES ACH PMT NO. - 80131876	282,087.16
US BANK P CARD PAYMENTS	MINOR EQUIPMENT ACH PMT NO. - 80131973	2,880.83

TOTAL FOR 5902 - PROPERTY ACQUISITION POLICE ----- 284,967.99

5903 - PROPERTY ACQUISITION FIRE

L N CURTIS & SONS	PERSONAL PROTECTIVE EQUIPMENT ACH PMT NO. - 80131992	484.46
-------------------	---	--------

TARGETSOLUTIONS LEARNING LLC SOFTWARE (NONCAPITALIZED)
ACH PMT NO. - 80131923 10,951.78

HONORABLE MAYOR
AND COUNCIL MEMBERS

08/05/24
PAGE 35

PROCESSING OF VOUCHERS RESULTS IN CLAIMS AS FOLLOWS:

US BANK P CARD PAYMENTS	MINOR EQUIPMENT ACH PMT NO. - 80131973	571.04
YP AUTOMOTIVE INC DBA GMC OF RIVERFRONT PARK	VEHICLES CHECK NO. - 00604672	676.17
TOTAL FOR 5903 - PROPERTY ACQUISITION FIRE		12,683.45

6100 - RETIREMENT

US BANK P CARD PAYMENTS	OTH DUES/SUBSCRIPTNS/MEMBERSHP ACH PMT NO. - 80131973	166.54
TOTAL FOR 6100 - RETIREMENT		166.54

6200 - FIREFIGHTERS' PENSION FUND

ADVANCED HEARING LLC	SERVICE REIMBURSEMENT CHECK NO. - 00604718	489.84
DELTA DENTAL OF WASHINGTON	SERVICE REIMBURSEMENT ACH PMT NO. - 80132079	1,010.00
FAIRWINDS SPOKANE LLC	SERVICE REIMBURSEMENT CHECK NO. - 00604720	10,795.00
JAMES KRAFT	SERVICE REIMBURSEMENT CHECK NO. - 00604722	3.99
JAMES T BURKE	SERVICE REIMBURSEMENT CHECK NO. - 00604719	83.96
KJERSTEN HERON PLLC DBA DIVISION STREET DENTAL	SERVICE REIMBURSEMENT CHECK NO. - 00604721	65.35
LIFEWISE ASSURANCE CO	INSURANCE ADMINISTRATION ACH PMT NO. - 80132042	3,386.75
NORTH RIDGE HOUSE INC	SERVICE REIMBURSEMENT ACH PMT NO. - 80132048	5,000.00
NORTH RIDGE HOUSE INC	SERVICE REIMBURSEMENT ACH PMT NO. - 80132048	4,921.00
PREMERA BLUE CROSS OR SPOKANE CITY TREASURER	SERVICE REIMBURSEMENT ACH PMT NO. - 80132008	70,383.24
UNITED STATES TREASURY DEPT OF THE TREASURY	INSURANCE ADMINISTRATION CHECK NO. - 00604654	518.68
TOTAL FOR 6200 - FIREFIGHTERS' PENSION FUND		96,657.81

6255 - LAW ENFORCEMENT RECORDS MGMT

PROCESSING OF VOUCHERS RESULTS IN CLAIMS AS FOLLOWS:

SPOKANE COUNTY TREASURER	DEPOSIT-POLICE GUN PERMITS ACH PMT NO. - 80132010	5,617.00
TOTAL FOR 6255 - LAW ENFORCEMENT RECORDS MGMT		5,617.00

6300 - POLICE PENSION		

CLIFFORD WALTER	SERVICE REIMBURSEMENT CHECK NO. - 00604748	169.00
DELTA DENTAL OF WASHINGTON	SERVICE REIMBURSEMENT ACH PMT NO. - 80132079	2,307.00
LIFEWISE ASSURANCE CO	INSURANCE ADMINISTRATION ACH PMT NO. - 80132042	2,490.90
MULTICARE HEALTH SYSTEMS DBA MULTICARE HOSPITAL	SERVICE REIMBURSEMENT CHECK NO. - 00604744	61.00
PREMERA BLUE CROSS OR SPOKANE CITY TREASURER	SERVICE REIMBURSEMENT ACH PMT NO. - 80132008	63,026.89
TERRY CARE GROUP LLC dba MURANO SENIOR LIVING	SERVICE REIMBURSEMENT CHECK NO. - 00604746	7,500.00
TERRY CARE GROUP LLC dba MURANO SENIOR LIVING	SERVICE REIMBURSEMENT CHECK NO. - 00604746	1,680.00
UNITED STATES TREASURY DEPT OF THE TREASURY	INSURANCE ADMINISTRATION CHECK NO. - 00604654	410.29
TOTAL FOR 6300 - POLICE PENSION		77,645.08

TOTAL CLAIMS		8,385,703.18

**Agenda Sheet for City Council:****Committee: Date:** N/A**Committee Agenda type:****Date Rec'd**

7/24/2024

Clerk's File #

CPR 2024-0003

Cross Ref #**Project #****Council Meeting Date:** 08/12/2024**Submitting Dept**

ACCOUNTING & GRANTS

Bid #**Contact Name/Phone**

MICHELLE 6032

Requisition #**Contact E-Mail**

MMURRAY@SPOKANECITY.ORG

Agenda Item Type

Claim Item

Council Sponsor(s)**Agenda Item Name**

5600-ACCOUNTING-PAYROLL

Agenda Wording

Report of the Mayor of pending payroll claims of previously approved obligations through: July 20, 2024.
 Payroll check #573467 through check #573735 \$9,666,801.54

Summary (Background)

N/A

Lease? NO Grant related? NO Public Works? NO

Fiscal Impact

Approved in Current Year Budget?

Total Cost \$

Current Year Cost \$

Subsequent Year(s) Cost \$

Narrative**Amount****Budget Account**

Expense \$ 9,666,801.54

Various

Select \$

#

Select \$

#

Select \$

#

\$

#

\$

#

PAYROLL RECAP BY FUND
PAY PERIOD ENDING JULY 20, 2024

FUND	FUND NAME	TOTAL
0100	GENERAL FUND	
0030	POLICE OMBUDSMAN	13,505.05
0230	CIVIL SERVICE	46,634.00
0260	CITY CLERK	21,707.21
0320	COUNCIL	59,617.60
0330	PUBLIC AFFAIRS / COMMUNICATIONS	37,999.05
0370	ENGINEERING SERVICES	208,890.87
0410	FINANCE	37,980.36
0450	CD/HS DIVISION	14,076.00
0470	HISTORIC PRESERVATION	8,064.80
0480	OFFICE OF CIVIL RIGHTS,EQUITY, & INCLUSION	8,419.20
0500	LEGAL	148,171.70
0520	MAYOR	36,201.20
0550	NEIGHBORHOOD SERVICES	24,757.00
05601	MUNICIPAL COURT	131,864.86
0570	OFFICE OF HEARING EXAMINER	6,786.40
0620	HUMAN RESOURCES	33,794.76
0650	PLANNING SERVICES	66,104.80
0680	POLICE	2,221,158.47
0690	PROBATION SERVICES	82,804.17
0700	PUBLIC DEFENDERS	99,377.69
0750	ECONOMIC DEVELOPMENT	9,857.60
0860	TREASURER	0.00
	TOTAL GENERAL FUND	3,317,772.79

FUND	FUND NAME	TOTAL
1100	STREET	287,963.98
1200	CODE ENFORCEMENT	69,176.23
1300	LIBRARY	282,012.86
1380	TRAFFIC CALMING MEASURES	3,317.60
1390	URBAN FORESTRY	2,719.20
1400	PARKS AND RECREATION	600,922.25
1425	AMERICAN RESCUE PLAN	2,262.63
1460	PARKING METER	36,082.20
1595	HOUSING SALES TAX	0.00
1620	PUBLIC SAFETY & JUDICIAL GRANT	14,240.02
1625	PUBLIC SAFETY PERSONNEL	198,017.52
1680	CD/HS	71,909.33
1910	CRIMINAL JUSTICE ASSISTANCES	2,460.00
1970	EMS FUND	1,892,658.74
4100	WATER	517,583.08
4250	INTEGRATED CAPITAL FUND	62,338.21
4300	SEWER	660,735.50
4480	REFUSE	651,397.26
4600	GOLF	88,577.74
4700	GENERAL SERVICES FUND	201,162.31
5100	FLEET SERVICE	130,274.30
5200	PUBLIC WORKS & UTILITY FUND	58,047.56
5300	MIS	195,802.83
5400	REPROGRAPHICS	5,190.42
5500	PURCHASING	28,420.80
5600	ACCOUNTING SERVICES	132,478.63
5700	MY SPOKANE	37,064.68
5750	PROJECT MANAGEMENT OFFICE	28,164.80
5800	RISK MANAGEMENT	14,342.40
5810	WORKER'S COMPENSATION	9,773.60
5830	SELF-FUNDED MEDICAL/DENTAL	8,967.46
5900	ASSET MANAGEMENT	44,877.41
6060	CITY RETIREMENT	10,087.20
	TOTAL	9,666,801.54

**Agenda Sheet for City Council:****Committee: Date:** N/A**Committee Agenda type:****Date Rec'd**

8/7/2024

Clerk's File #

CPR 2024-0003

Cross Ref #**Project #****Council Meeting Date:** 08/12/2024**Submitting Dept**

ACCOUNTING & GRANTS

Bid #**Contact Name/Phone**

MICHELLE 6032

Requisition #**Contact E-Mail**

MMURRAY@SPOKANECITY.ORG

Agenda Item Type

Claim Item

Council Sponsor(s)**Agenda Item Name**

5600-ACCOUNTING-PAYROLL

Agenda Wording

Report of the Mayor of pending payroll claims of previously approved obligations through: August 3, 2024.
 Payroll check #573736 through check #573979 \$9,978,036.23

Summary (Background)

N/A

Lease? NO Grant related? NO Public Works? NO

Fiscal Impact

Approved in Current Year Budget?

Total Cost \$

Current Year Cost \$

Subsequent Year(s) Cost \$

Narrative**Amount****Budget Account**

Expense \$ 9,978,036.23

Various

Select \$

#

Select \$

#

Select \$

#

\$

#

\$

#

PAYROLL RECAP BY FUND
PAY PERIOD ENDING AUGUST 3, 2024

FUND	FUND NAME	TOTAL
0100	GENERAL FUND	
0030	POLICE OMBUDSMAN	13,328.80
0230	CIVIL SERVICE	46,681.68
0260	CITY CLERK	19,160.81
0320	COUNCIL	58,769.60
0330	PUBLIC AFFAIRS / COMMUNICATIONS	31,603.20
0370	ENGINEERING SERVICES	247,827.95
0410	FINANCE	40,660.95
0450	CD/HS DIVISION	14,076.00
0470	HISTORIC PRESERVATION	8,064.80
0480	OFFICE OF CIVIL RIGHTS,EQUITY, & INCLUSION	8,419.20
0500	LEGAL	206,669.70
0520	MAYOR	35,947.28
0550	NEIGHBORHOOD SERVICES	13,837.60
05601	MUNICIPAL COURT	131,561.09
0570	OFFICE OF HEARING EXAMINER	6,786.40
0620	HUMAN RESOURCES	34,205.92
0650	PLANNING SERVICES	66,104.80
0680	POLICE	2,285,227.76
0690	PROBATION SERVICES	56,424.83
0700	PUBLIC DEFENDERS	25,342.40
0750	ECONOMIC DEVELOPMENT	99,381.69
0860	TREASURER	9,857.60
	TOTAL GENERAL FUND	3,459,940.06

FUND	FUND NAME	TOTAL
1100	STREET	284,924.07
1200	CODE ENFORCEMENT	68,930.15
1300	LIBRARY	279,023.70
1380	TRAFFIC CALMING MEASURES	3,317.60
1390	URBAN FORESTRY	2,719.20
1400	PARKS AND RECREATION	592,954.18
1425	AMERICAN RESCUE PLAN	2,199.38
1460	PARKING METER	36,143.43
1595	HOUSING SALES TAX	0.00
1620	PUBLIC SAFETY & JUDICIAL GRANT	13,640.63
1625	PUBLIC SAFETY PERSONNEL	200,954.89
1680	CD/HS	66,382.60
1910	CRIMINAL JUSTICE ASSISTANCES	2,460.00
1970	EMS FUND	2,045,406.83
4100	WATER	505,996.93
4250	INTEGRATED CAPITAL FUND	62,393.20
4300	SEWER	656,172.83
4480	REFUSE	660,585.81
4600	GOLF	85,563.43
4700	GENERAL SERVICES FUND	206,000.78
5100	FLEET SERVICE	132,421.92
5200	PUBLIC WORKS & UTILITY FUND	58,784.97
5300	MIS	232,104.09
5400	REPROGRAPHICS	5,194.40
5500	PURCHASING	28,420.80
5600	ACCOUNTING SERVICES	132,428.82
5700	MY SPOKANE	37,278.03
5750	PROJECT MANAGEMENT OFFICE	28,164.80
5800	RISK MANAGEMENT	14,342.40
5810	WORKER'S COMPENSATION	9,773.60
5830	SELF-FUNDED MEDICAL/DENTAL	8,713.15
5900	ASSET MANAGEMENT	44,612.35
6060	CITY RETIREMENT	10,087.20
	TOTAL	9,978,036.23

MINUTES OF SPOKANE CITY COUNCIL

Monday, July 8, 2024

BRIEFING SESSION

The Briefing Session of the Spokane City Council held on the above date was called to order at 3:30 p.m. in the Council Chambers in the Lower Level of the Municipal Building, 808 West Spokane Falls Boulevard, Spokane, Washington.

Roll Call

On roll call, Council President Wilkerson and Council Members Bingle (appearing virtually), Cathcart, Dillon, Klitzke, Navarrete, and Zappone were present.

Interim City Administrator Garrett Jones, City Attorney; Giacobbe Byrd, Director-City Council Office; City Council Policy Advisor Chris Wright; and City Clerk Terri Pfister were also present for the meeting.

Advance Agenda Review

The City Council began the meeting by receiving an overview from Airport staff on Resolution 2024-0065—Joint Resolution of the Board of County Commissioners and Spokane Airport Board authorizing Spokane County to issue its Airport Revenue Bonds—on the July 8, 2024, Advance Agenda. Remaining Advance Agenda items were briefed following West Quadrant candidate interviews and Current Agenda Review. (See section below titled “Advance Agenda Review (Continued).”

Candidate Interviews – West Quadrant Project Advisory Committee

The City Council interviewed Liz Marlin and Wende Wilbur, candidates for appointment to the West Quadrant Project Advisory Committee.

Motion by Council Member Zappone, seconded by Council Member Dillon, **to defer** the two appointments (of Liz Marlin and Wende Wilbur) to next week (July 15, 2024); **carried 7-0.**

Current Agenda Review

The City Council reviewed the July 8, 2024, Current Agenda.

Memorandum of Understanding with the Spokane Police Guild (and Captains and Lieutenants Association) (Council Sponsors: Council President Wilkerson and Council Members Dillon and Cathcart)

***Motion** by Council Member Zappone, seconded by Council Member Dillon, **to suspend** Council Rules and **add** the Memorandum of Understanding with the Spokane Police Guild (and Captains and Lieutenants Association) to offer a voluntary retirement incentive to

eligible Guild members as a Salary Savings Plan. (Council Sponsors: Council President Wilkerson and Council Members Dillon and Cathcart); **carried 7-0.**

*Due to a clerical error in the agenda submission, the Captains and Lieutenants Memorandum of Understanding was not referenced on the agenda submission sheet for this matter; however, the Captains and Lieutenants agreement was included in the City Council packet material and Finance Director Matt Boston reported on both items during the City Council's 3:30 p.m. Briefing Session. In communication with City Council staff following the meeting, it was noted that Council's intent was to consider both Memorandums of Understanding.

Special Budget Ordinance C36521 (Deferred from May 20, 2024, Agenda (Council Sponsors: Council Members Dillon, Cathcart, and Navarrete)

Motion by Council Member Klitzke, seconded by Council Member Cathcart, **to defer indefinitely** Special Budget Ordinance C36521 arising from needs throughout the police investigative unit; **carried 7-0.**

Special Budget Ordinance C36538 (Council Sponsors: Council President Wilkerson and Council Members Cathcart and Zappone)

Motion by Council Member Zappone, seconded by Council Member Klitzke, **to adopt** the Zappone Proposed Amendment to Special Budget Ordinance C36538—arising from the need to adjust the General Fund budget—filed July 5, 2024 (amends previous version by replacing with updated amended version); **carried 5-2.**

Resolution 2024-0055 (Council Sponsors: Council Members Zappone, Bingle, and Dillon)

Motion by Council Member Cathcart, seconded by Council Member Dillon, **to adopt** the Cathcart Proposed Amendment to Attachment A to Resolution 2024-0055, adopting the City of Spokane's federal legislative agenda for the years 2024-2025, filed July 5, 2024; **carried 7-0.**

Resolution 2024-0062 (Council Sponsors: Council President Wilkerson and Council Members Zappone and Klitzke)

Motion by Council Member Zappone, seconded by Council Member Klitzke, **to defer** Resolution 2024-0062—relating to the Traffic Calming Fund requesting the mayor use current funding to establish a Sidewalk Improvement and Repair Pilot Program—to July 22, 2024, Agenda; **carried 7-0.**

Final Reading Ordinance C36534 (Council Sponsors: Council Members Dillon and Klitzke)

Motion by Council Member Dillon, seconded by Council Member Klitzke, **to adopt** the Dillon Proposed Amendment amending the previous version of Ordinance C36534—titled “Gun Violence Prevention for a Safer Spokane,” relating to the establishment provisions relating to firearms safety and prevention—with proposed updates filed July 3, 2024; **carried 5-2.**

Motion by Council Member Bingle, seconded by Council Member Cathcart, **to defer** Final Reading Ordinance C36534—titled “Gun Violence Prevention for a Safer Spokane,” relating to the establishment provisions relating to firearms safety and prevention—to July 22, 2024; **rejected 2-5.**

Action to Approve July 8, 2024, Current Agenda (as amended)

Following staff reports and Council inquiry and discussion regarding the July 8, 2024, Current Agenda items, the City Council took the following action (pursuant to Council Rule 2.1.B):

Motion by Council Member Klitzke, seconded by Council Member Zappone, **to approve** the July 8, 2024, Current Agenda (as amended); **carried 6-1.**

Advance Agenda Review (Continued)

The City Council received an overview of the June 15, 2024, Advance Agenda items.

First Reading Ordinance C36543

Motion by Council Member Cathcart, seconded by Council Member Klitzke, **to defer** First Reading Ordinance C36543—designating the Lunar New Year, Martin Luther King Jr. Day and Juneteenth as official City of Spokane holidays—to August 12, 2024; **carried 7-0.**

First Reading Ordinance C36544

Motion by Council Member Cathcart, seconded by Council Member Klitzke, **to defer** First Reading Ordinance C36544—prohibiting illegal encampments near facilities offering comprehensive support services—to August 12, 2024, with the final reading then occurring on August 19; **carried 7-0.**

Action to Approve July 15, 2024, Advance Agenda

Following staff reports and Council inquiry and discussion regarding the July 15, 2024, Advance Agenda items, the City Council took the following action (pursuant to Council Rule 2.1.B):

Motion by Council Member Zappone, seconded by Council Member Klitzke, **to approve** the July 15, 2024, Advance Agenda; **carried 7-0.**

Council Recess/Executive Session

The City Council recessed at 4:54 p.m. No Executive Session was held. The City Council reconvened at 6:00 p.m. for the Legislative Session.

LEGISLATIVE SESSION

Land Acknowledgement

Council President Wilkerson started the meeting off by reading the “Land Acknowledgement” (adopted by City Council on March 22, 2021, under Resolution 2021-0019) which appears on page 2 of the agenda.

Pledge of Allegiance

The Pledge of Allegiance was led by Council President Wilkerson.

Roll Call

On roll call, Council President Wilkerson and Council Members Bingle (appearing virtually), Cathcart, Dillon, Klitzke, Navarrete, and Zappone were present.

Giacobbe Byrd, Director-City Council Office; City Council Policy Advisor Chris Wright; and City Clerk Terri Pfister were also present for the meeting.

There were no **Mayoral Proclamations**.

There were no **Reports from Community Organizations**.

BOARDS AND COMMISSIONS APPOINTMENTS

Appointment to Plan Commission (CPR 1981-0295)

Motion by Council Member Klitzke, seconded by Council Member Zappone, **to approve** (and thereby confirm) the appointment of Jill Yotz to the Plan Commission to serve a three-year term from July 8, 2024, to July 8, 2027; **carried 5-2**.

Upon 7-0 Voice Vote, the City Council **approved** (and thereby confirmed) the appointments of EJ Iannelli, Alan Chatham, Kimberly Lawrence, Amanda Richardson, and Fran Papenleur to the West Quadrant Project Advisory Committee to serve three-year terms from July 8, 2024, to July 8, 2027; **carried 7-0**.

CONSENT AGENDA

After public testimony and Council commentary, the following action was taken:

Upon 7-0 Voice Vote, the City Council **approved** Staff Recommendations for the following items; **carried 7-0**:

Purchase from Correctional Industries (Tumwater, WA) of sixty-six metal trash cans and sixty-six metal recycling bins for use in the downtown core—\$216,769.61 (incl. tax). (OPR

2024-0522) (Council Sponsors: Council President Wilkerson and Council Members Bingle and Klitzke)

Purchase from Consolidated Electrical Distributors dba Columbia Electric Supply (Spokane Valley, WA) of 480V transformers, switch gear, panels, and associated electrical supplies to upgrade the electrical system at Upriver Dam—\$238,208.60. (OPR 2024-0523 / RFQ 6139-24) (Council Sponsors: Council President Wilkerson and Council Members Bingle and Klitzke)

Five-year Value Blanket with Oxarc (Spokane) for as-needed purchase of Sulfuric Acid Solution H₂SO₄ 50% for the Riverside Park Water Reclamation Facility from July 15, 2024, through July 14, 2029—estimated total cost \$263,050. (OPR 2024-0524 / RFQ 6138-24) (Council Sponsors: Council President Wilkerson and Council Members Bingle and Klitzke)

Public Works Agreement with McKinstry, Co. LLC (Spokane) for burner and boiler controls upgrade at the Riverside Park Water Reclamation Facility from June 15, 2024, through March 31, 2025—not to exceed \$369,800 (plus tax, if applicable). (OPR 2024-0525 / PW ITB 6128-24) (Council Sponsors: Council President Wilkerson and Council Members Bingle and Klitzke)

Two-year Value Blanket with Pomp Tire Services (Spokane) for purchase of tires and tire-related products for the Fleet Services Department—\$800,000 annually. (OPR 2024-0526) (Council Sponsors: Council President Wilkerson and Council Members Cathcart and Zappone)

Personal Service Agreement with Pomp Tire Services (Spokane) for miscellaneous tire services for the Fleet Services Department from July 1, 2024, through June 30, 2029—\$380,000 annually (plus tax, if applicable). (OPR 2024-0527) (Council Sponsors: Council President Wilkerson and Council Members Cathcart and Zappone)

Public Works Contract with McLintock & Turk, Inc. (Spokane) for the Nelson Facility Compressed Natural Gas Fuel System Expansion Project Phases 2, 3 and 4, from August 1, 2024, through December 31, 2026—not to exceed \$300,929 (plus tax, if applicable) (\$84,220 in 2024 for Phase 2, \$94,496 in 2025 for Phase 3, and \$122,213 in 2026 for Phase 4). (OPR 2024-0528 / PW ITB 6108-24) (Council Sponsors: Council President Wilkerson and Council Members Cathcart and Zappone)

Contract Renewal 4 of 4 with Racom, Inc. (Spokane Valley, WA) for commissioning, radio, and electrical equipment installation for fleet vehicles—not to exceed \$150,000 (plus tax, if applicable). (OPR 2019-0885 / RFP 5153-20) (Council Sponsors: Council President Wilkerson and Council Members Cathcart and Zappone)

Personal Services Agreement with Abadan Reprographics (Spokane) for reprographics services for the Engineering Services Department from July 1, 2024, through June 30, 2026—not to exceed \$125,000 (plus tax, if applicable, and in accordance with the pricing

form attached in Exhibit B). (OPR 2024-0529 / IRFP 6151-24) (Council Sponsors: Council President Wilkerson and Council Members Bingle and Klitzke)

Escrow Agreement and Warranty Deed with Daniel G. Ghebreab and Rahel Araya to acquire needed property for the Palouse-Freya Roundabout—\$255,000 (plus closing costs). (OPR 2024-0530 / ENG 2023133) (Council Sponsors: Council President Wilkerson and Council Members Bingle and Klitzke)

Consultant Agreement with Integrus Architecture, P.S. (Spokane) for a public space concept study and space programming with the intent of addressing public facing departments in City Hall for floors one through three from July 1, 2024, through December 31, 2024—\$70,260 (plus tax, if applicable). (OPR 2024-0531) (Council Sponsors: Council President Wilkerson and Council Members Cathcart and Zappone)

Public Works Agreement with The Hiller Companies, LLC (Spokane Valley, WA) for clean agent fire suppression panel and component replacement at the Police Evidence Facility from July 13, 2024, through December 31, 2024—not to exceed \$66,485 (plus tax, if applicable). (OPR 2024-0532 / RFB 24-007) (Council Sponsors: Council President Wilkerson and Council Members Cathcart and Zappone)

Report of the Mayor of pending:

Claims and payments of previously approved obligations, including those of Parks and Library, through June 21, 2024, total \$8,395,023.18 (Check Nos.: 603768 – 603897; Credit Card Nos.: 000280 – 000304; ACH Payment Nos.: 130570 – 130741), with Parks and Library claims approved by their respective boards. Warrants excluding Parks and Library total \$8,090,781.31. (CPR 2024-0002)

Claims and payments of previously approved obligations, including those of Parks and Library, through June 28, 2024, total \$16,042,647.39 (Check Nos.: 603898 – 604046; Credit Card Nos.: 000305 – 000336; ACH Payment Nos.: 130742 - 130956, with Parks and Library claims approved by their respective boards. Warrants excluding Parks and Library total \$15,737,548.21. (CPR 2024-0002)

Payroll claims of previously approved obligations through June 22, 2024: \$9,536,770.32 (Payroll Check Nos. 572898 through check #573189). (CPR 2024-0003)

City Council Meeting Minutes: May 23 and June 10, 2024. (CPR 2024-0013)

City Council Finance & Administration Standing Committee Meeting Minutes: June 3 and June 24, 2024. (CPR 2024-0015)

Memorandums of Understanding with the Spokane Police Guild and Captains and Lieutenants Association to offer a voluntary retirement incentive to eligible Guild members and Captains and Lieutenants members as Salary Savings Plans. (OPR 2024-0553 and

OPR 2024-0562) (As added during the 3:30 p.m. Briefing Session) (Council Sponsors: Council President Wilkerson and Council Members Dillon and Cathcart)

LEGISLATIVE AGENDA

SPECIAL BUDGET ORDINANCES

For Council action on Special Budget Ordinance C36521, see section of minutes under 3:30 p.m. Briefing Session.

Special Budget Ordinance C36537 (Council Sponsors: President Wilkerson and Council Members Cathcart and Zappone)

After public testimony from one individual and an opportunity for Council commentary, with none provided, the following action was taken:

Upon 7-0 Roll Call Vote, the City Council **passed Special Budget Ordinance C36537** amending Ordinance No. C36467 passed by the City Council November 27, 2023, and entitled, "An Ordinance adopting the Annual Budget of the City of Spokane for 2024, making appropriations to the various funds of the City of Spokane government for the fiscal year ending December 31, 2024, and providing it shall take effect immediately upon passage," and declaring an emergency and appropriating funds in:

Water-Wastewater Fund

1) Increase appropriation by \$1,413,103.

A) Of the increased appropriation, \$955,117 is provided solely for city utility tax in the Sewer Maintenance department.

B) Of the increased appropriation, \$337,986 is provided solely for city utility tax in the Riverside Park Reclamation Facility department.

C) Of the increased appropriation, \$80,000 is provided solely for city utility tax in the Water department.

D) Of the increased appropriation, \$40,000 is provided solely for city utility tax in the Integrated Capital Management department.

and

Solid Waste Fund

2) Increase appropriation by \$3,348,500.

A) Of the increased appropriation, \$2,830,000 is to be provided solely for fleet maintenance in the Solid Waste Collection department.

B) Of the increased appropriation, \$362,500 is to be provided solely for city utility tax in the Solid Waste Collection department.

C) Of the increased appropriation, \$156,000 is to be provided solely for city utility tax in the Solid Waste Disposal department.

(This action arises from the need to adjust various Enterprise funds.)

Ayes: Bingle, Cathcart, Dillon, Klitzke, Navarrete, Wilkerson, and Zappone
Nos: None
Abstain: None
Absent: None

Special Budget Ordinance C36538 (As amended during the 3:30 p.m. Briefing Session) (Council Sponsors: President Wilkerson and Council Members Cathcart and Zappone)

After an opportunity for public testimony, with none provided, and Council commentary, the following action was taken:

Upon 5-2 Roll Call Vote, the City Council **passed Special Budget Ordinance C36538**, as amended, amending Ordinance No. C36467 passed by the City Council November 27, 2023, and entitled, "An Ordinance adopting the Annual Budget of the City of Spokane for 2024, making appropriations to the various funds of the City of Spokane government for the fiscal year ending December 31, 2024, and providing it shall take effect immediately upon passage," and declaring an emergency and appropriating funds in:

Increasing General Fund revenue by \$1,871,00, Fire/EMS Fund revenue by \$300,000, and Traffic Calming Measure Fund revenue by \$437,000 and providing recommendations to adjust material budget variances per SMC 07.14.030(C)(3). This ordinance covers increases, decreases, and other adjustments for the following departments: Spokane Police Department, Management and Budget Office, Internal Audit, Clerk's Office, Council Office, Mayor's Office, Police Ombudsman, as well as other departments as described in the ordinance.

(This action arises from the need to adjust the General Fund budget.)

Ayes: Dillon, Klitzke, Navarrete, Wilkerson, and Zappone
Nos: Bingle and Cathcart
Abstain: None
Absent: None

Special Budget Ordinance C36539 (Council Sponsors: President Wilkerson and Council Members Cathcart and Zappone)

After an opportunity for public testimony and Council commentary, with no individuals requesting to speak, the following action was taken:

Upon 7-0 Roll Call Vote, the City Council **passed Special Budget Ordinance C36539** amending Ordinance No. C36467 passed by the City Council November 27, 2023, and entitled, "An Ordinance adopting the Annual Budget

of the City of Spokane for 2024, making appropriations to the various funds of the City of Spokane government for the fiscal year ending December 31, 2024, and providing it shall take effect immediately upon passage," and declaring an emergency and appropriating funds in:

Fleet Services Fund

- 1) Increase revenue by \$2,400,000.
 - A) Of the increased revenue, \$2,400,000 is provided solely for interfund vehicle/equipment repair.
- 2) Increase appropriation by \$2,400,000.
 - A) Of the increased appropriation, \$1,000,000 is provided solely for vehicle repair & maintenance supply.
 - B) Of the increased appropriation, \$1,200,000 is provided solely for equipment repairs & maintenance.
 - C) Of the increased appropriation, \$200,000 is provided solely for contractual services.

and

Management Information Services Fund

- 1) Decrease appropriation by \$206,669.
 - A) Of the decreased appropriation, \$205,000 is removed solely from software maintenance.
 - B) Of the decreased appropriation, \$1,669 is removed from base wages and associated employee benefits.

and

Reprographics Fund

- 1) Decrease appropriation by \$36,864.
 - A) Of the decreased appropriation, \$18,600 is removed solely from equipment repairs/maintenance.
 - B) Of the decreased appropriation, \$18,264 is removed solely from hardware maintenance.

and

Utility Billing Fund

- 1) Decrease appropriation by \$1,797.
 - A) Of the decreased appropriation, \$1,797 is removed from base wages and associated employee benefits.

(This action arises from the need to adjust various Internal Services funds.)

Ayes: Bingle, Cathcart, Dillon, Klitzke, Navarrete, Wilkerson, and Zappone

Nos: None
Abstain: None
Absent: None

Special Budget Ordinance C36540 (Council Sponsors: President Wilkerson and Council Members Cathcart and Zappone)

After public testimony from one individual and an opportunity for Council commentary, with no individuals requesting to speak, the following action was taken:

Upon 7-0 Roll Call Vote, the City Council **passed Special Budget Ordinance C36540** amending Ordinance No. C36467 passed by the City Council November 27, 2023, and entitled, "An Ordinance adopting the Annual Budget of the City of Spokane for 2024, making appropriations to the various funds of the City of Spokane government for the fiscal year ending December 31, 2024, and providing it shall take effect immediately upon passage," and declaring an emergency and appropriating funds in:

Public Safety Personnel and Crime Reduction Fund

- 1) Eliminate one classified, vacant Crime Analyst (from 1 to 0) in the Police Crime Analysis program.
- 2) Decrease appropriation by \$113,582.
 - A) Of the decreased appropriation, \$113,582 is removed from base wages and associated employee benefits in the Police Crime Analysis program.

and

Forfeitures and Contributions Fund

- 1) Increase appropriation by \$520,500.
 - A) Of the increased appropriation, \$100,000 is to be provided solely for vehicles.
 - B) Of the increased appropriation, \$140,000 is to be provided solely for machinery/equipment.
 - C) Of the increased appropriation, \$160,000 is to be provided solely for software maintenance.
 - D) Of the increased appropriation, \$25,000 is to be provided solely for personal protective equipment.
 - E) Of the increased appropriation, \$70,000 is to be provided solely for confidential funds.
 - F) Of the increased appropriation, \$15,000 is to be provided solely for registration/schooling.
 - G) Of the increased appropriation, \$10,500 is to be provided solely for operating supplies.

and

Traffic Calming Measures Fund

1) Increase appropriation by \$50,000.
A) Of the increased appropriation, \$50,000 is to be provided solely for fleet maintenance.

and

Library Fund

1) Decrease appropriation by \$1,434.
A) Of the decreased appropriation, \$1,434 is removed from base wages and associated employee benefits.

and

Park Fund

1) Decrease appropriation by \$1,582.
A) Of the decreased appropriation, \$1,582 is removed from base wages and associated employee benefits.

(This action arises from the need to adjust various Special Revenue funds.)

Ayes: Bingle, Cathcart, Dillon, Klitzke, Navarrete, Wilkerson, and Zappone
Nos: None
Abstain: None
Absent: None

Special Budget Ordinance C36542 (Council Sponsors: President Wilkerson and Council Members Cathcart and Zappone)

After an opportunity for public testimony and Council commentary, with no individuals requesting to speak, the following action was taken:

Upon 7-0 Roll Call Vote, the City Council **passed Special Budget Ordinance C36542** amending Ordinance No. C36467 passed by the City Council November 27, 2023, and entitled, "An Ordinance adopting the Annual Budget of the City of Spokane for 2024, making appropriations to the various funds of the City of Spokane government for the fiscal year ending December 31, 2024, and providing it shall take effect immediately upon passage," and declaring an emergency and appropriating funds in:

Regarding changes to various Funds to make grade and associated pay range changes for various positions (for the second quarter of 2024, as more specifically described in the ordinance).

(This action arises from the need to adjust pay ranges to align with salary analysis.)

Ayes: Bingle, Cathcart, Dillon, Klitzke, Navarrete, Wilkerson, and Zappone
Nos: None
Abstain: None
Absent: None

There were no **Emergency Ordinances**.

RESOLUTIONS

Resolution 2024-0055 (As amended during the 3:30 p.m. Briefing Session) (Deferred from June 24, 2024, Agenda) (Council Sponsors: Council Members Zappone, Bingle, and Dillon)

After public testimony from one individual and an opportunity for Council commentary, with none provided, the following action was taken:

Upon 7-0 Roll Call Vote, the City Council **adopted Resolution 2024-0055**, as amended, adopting the City of Spokane's federal legislative agenda for the years 2024-2025.

Ayes: Bingle, Cathcart, Dillon, Klitzke, Navarrete, Wilkerson, and Zappone
Nos: None
Abstain: None
Absent: None

For Council action on Resolution 2024-0062, see section of minutes under 3:30 p.m. Briefing Session.

Resolution 2024-0063 (and associated Value Blanket Order OPR 2024-0534) (Council Sponsors: Council President Wilkerson and Council Members Bingle and Klitzke)

After an opportunity for public testimony and Council commentary, with none provided, the following action was taken:

Upon 7-0 Roll Call Vote, the City Council **adopted Resolution 2024-0063** declaring Whitney Equipment Company, Inc. (Woodinville, WA) a sole-source provider and authorizing the City to enter into a value blanket order for Teledyne ISCO Flow Monitoring Systems Parts and Supplies for a five (5) year period from August 1, 2024, through July 31, 2029— approximately \$680,000.00 without public bidding.

Ayes: Bingle, Cathcart, Dillon, Klitzke, Navarrete, Wilkerson, and Zappone
Nos: None

Abstain: None
Absent: None

Resolution 2024-0064 (Council Sponsors: Council Members Zappone and Klitzke)

After an opportunity for public testimony and Council commentary, with none provided, the following action was taken:

Upon 7-0 Roll Call Vote, the City Council **adopted Resolution 2024-0064** setting hearing before the City Council for August 12, 2024, for the vacation of the alley between Lee Street and Stone Street, from the south line of Broadway Ave to the north line of Springfield Avenue, as requested by Richard Clemson.

Ayes: Bingle, Cathcart, Dillon, Klitzke, Navarrete, Wilkerson, and Zappone
Nos: None
Abstain: None
Absent: None

FINAL READING ORDINANCES

Final Reading Ordinance C36532 (As amended on June 24, 2024) (Council Sponsors: Council President Wilkerson and Council Members Navarrete and Dillon)

After an opportunity for public testimony and Council commentary, the following action was taken:

Upon 5-2 Roll Call Vote, the City Council **passed Final Reading Ordinance C36532**, as amended, relating to the City's Code of Ethics; adopting a new Chapter 01.04B of the Spokane Municipal Code and repealing Chapter 01.04A of the Spokane Municipal Code.

Ayes: Dillon, Klitzke, Navarrete, Wilkerson, and Zappone
Nos: Bingle and Cathcart
Abstain: None
Absent: None

Final Reading Ordinance C36533 (Council Sponsors: Council President Wilkerson and Council Members Navarrete and Dillon)

After an opportunity for public testimony, with none provided, and Council commentary, the following action was taken:

Upon 7-0 Roll Call Vote, the City Council **passed Final Reading Ordinance C36533** relating to Whistleblower Protection; adopting a new Chapter 01.04C of the Spokane Municipal Code.

Ayes: Bingle, Cathcart, Dillon, Klitzke, Navarrete, Wilkerson, and Zappone
Nos: None
Abstain: None
Absent: None

Final Reading Ordinance C36534 (As amended during the 3:30 p.m. Briefing Session) (Council Sponsors: Council Members Dillon and Klitzke)

After public testimony and Council commentary, the following actions were taken:

Motion by Council Member Dillon, seconded by Council Member Zappone, **to change** the 10.75.040 to 10.75.030 under section 1 – 10.75.030.F in Final Reading Ordinance C36534; **carried 7-0.**

Upon 5-2 Roll Call Vote, the City Council **passed Final Reading Ordinance C36534**, as amended, titled “Gun Violence Prevention for a Safer Spokane,” relating to the establishment provisions relating to firearms safety and prevention; adopting a new Chapter 10.75 to Title 10 of the Spokane Municipal Code, and repealing Section 12.05.065 of the Spokane Municipal Code.

Ayes: Dillon, Klitzke, Navarrete, Wilkerson, and Zappone
Nos: Bingle and Cathcart
Abstain: None
Absent: None

Final Reading Ordinance C36535 (Council Sponsors: Council Members Zappone, Bingle, and Klitzke)

After an opportunity for public testimony and Council commentary, with none provided, the following action was taken:

Upon 7-0 Roll Call Vote, the City Council **passed Final Reading Ordinance C36535** to adopt an overlay zone for property located at 1925 W. 36th Avenue in the City and County of Spokane, State of Washington, by amending the official zoning map to show a planned unit development overlay zone for said property.

Ayes: Bingle, Cathcart, Dillon, Klitzke, Navarrete, Wilkerson, and Zappone
Nos: None
Abstain: None
Absent: None

Final Reading Ordinance C36536 (Council Sponsors: Council Members Zappone, Bingle, and Klitzke)

After an opportunity for public testimony and Council commentary, with none provided, the following action was taken:

Upon 7-0 Roll Call Vote, the City Council **passed Final Reading Ordinance C36536** to adopt an overlay zone for property located at 4502 N. Havana Street, 4599 E. Longfellow Street, and 4522 E. Longfellow Avenue in the City and County of Spokane, State of Washington, by amending the official zoning map to show a planned unit development overlay zone for said property.

Ayes: Bingle, Cathcart, Dillon, Klitzke, Navarrete, Wilkerson, and Zappone
Nos: None
Abstain: None
Absent: None

There were no **First Reading Ordinances**.

There were no **Special Considerations**.

There were no **Hearings**.

[The City Clerk left the meeting at 7:08 p.m. (pursuant to Council Rule 2.2.A). Open Forum speaker information and motion of adjournment and adjournment time were provided by Council Director Giacobbe Byrd for the minutes.]

OPEN FORUM

Council President Wilkerson reviewed the rules of decorum for open forum. The following individual(s) spoke during the Open Forum:

- Christopher Savage
- Will Hulings
- Earl Moore
- Dennis Flynn
- Sunshine Wigen
- Megra Flatman
- Dave Bilslund
- Eugene Knowles
- Jack Talcott

- Cherrie Barnett
- Raul Pena
- Crystle Burgett

ADJOURNMENT

Motion by Council Member Cathcart, seconded by Council Member Klitzke, to adjourn;
carried 7-0.

There being no further business to come before the City Council, the meeting adjourned at 7:34 p.m.

Minutes prepared and submitted for publication in the July 24, 2024, issue of the *Official Gazette*.

Terri Pfister
City Clerk

Approved by Spokane City Council on August 12, 2024.

Betsy Wilkerson
City Council President

Attest:

Terri Pfister
City Clerk

MINUTES OF SPOKANE CITY COUNCIL

Monday, July 15, 2024

BRIEFING SESSION

The Briefing Session of the Spokane City Council held on the above date was called to order at 3:31 p.m. in the Council Chambers in the Lower Level of the Municipal Building, 808 West Spokane Falls Boulevard, Spokane, Washington.

Roll Call

On roll call, Council President Wilkerson and Council Members Bingle, Cathcart, Dillon, Klitzke, Navarrete, and Zappone were present.

Interim City Administrator Garrett Jones, City Attorney; Giacobbe Byrd, Director-City Council Office; City Council Policy Advisor Chris Wright; and City Clerk Terri Pfister were also present for the meeting.

Candidate Interview – Arts Commission

The City Council interviewed Julie Shepard, candidate for appointment to the Arts Commission.

Current Agenda Review

The City Council reviewed the July 15, 2024, Current Agenda.

Amendment to Agreement with Spokane County Sheriff's Office (OPR 2024-0064) (Council Sponsors: Council Members Cathcart, Dillon, and Navarrete)

Motion by Council Member Zappone, seconded by Council Member Klitzke, **to suspend** Council Rules for the purpose of adding the Amendment to Agreement with Spokane County Sheriff's Office in conjunction with the Mental Health Field Response Team Fiscal Year 2023 Grant Program; **carried 7-0.**

Motion by Council Member Zappone, seconded by Council Member Klitzke, **to add** the Amendment to Agreement with Spokane County Sheriff's Office in conjunction with the Mental Health Field Response Team Fiscal Year 2023 Grant Program; **carried 7-0.**

Special Consideration - Letter to Governor Inslee (CPR 2024-0016) (Council Sponsor: Council Member Cathcart)

Main Motion by Council Member Klitzke, seconded by Council Member Cathcart, **to adopt** the Klitzke Proposed Amendment to Special Considerations Item S1—City Council letter to Governor Inslee to direct the Department of Revenue to expedite the rulemaking process and publish finalized rules implementing State Bill 6175 before the end of this year—filed July 12, 2024; with

Motion by Council Member Klitzke, seconded by Council Member Cathcart, **to suspend** Council Rules to make minor adjustment to one word of the Klitzke Proposed Amendment; **carried 7-0; and.**

Motion by Council Member Klitzke, seconded by Council Member Cathcart, **to change** the wording in the last sentence of the Klitzke Proposed Amendment from “you” to “the governor;” **carried 7-0.**

Main motion, as amended, by Council Member Klitzke, seconded by Council Member Cathcart, **to adopt** the Klitzke Proposed Amendment to Special Considerations Item S1—City Council letter to Governor Inslee to direct the Department of Revenue to expedite the rulemaking process and publish finalized rules implementing State Bill 6175 before the end of this year—filed July 12, 2024; carried 7-0.

Final Reading Ordinance C36120 (First Reading held October 25, 2021) (Deferred from June 24, 2024, Agenda) (Council Sponsors: Council Members Zappone and Klitzke)

Motion by Council Member Cathcart, seconded by Council Member Klitzke, **to defer** Final Reading Ordinance C36120—vacating the east 55 feet of Adams Street from the south line of Third Avenue to the north line of I-90, together with the alley between Third Avenue and I-90, from the east line of Adams Street to the west line of Jefferson Street—to August 12, 2024, Agenda; **carried 7-0.**

Resolution 2024-0065 (Council Sponsors: Council President Wilkerson and Council Members Cathcart and Zappone)

Motion by Council Member Zappone, seconded by Council Member Klitzke, **to defer** Resolution 2024-0065—Joint Resolution of the Board of County Commissioners of Spokane County, Washington, the City Council of the City of Spokane, Washington, and the Spokane Airport Board authorizing Spokane County to issue its Airport Revenue Bonds to pay all or part of the cost of certain improvements to airport facilities; authorizing Spokane County to fix, by subsequent resolution, terms and covenants of such bonds; authorizing Spokane County to pledge or otherwise obligate the revenues of the airport; authorizing Spokane County to sell such bonds and to provide for the delivery thereof to the purchaser; and providing for other matters relating thereto—to July 22, 2024, Agenda; **carried 7-0.**

Advance Agenda Review

The City Council received an overview of the July 22, 2024, Advance Agenda items.

First Reading Ordinance C36556 (Council Sponsors: Council Members Zappone, Klitzke, and Bingle)

Motion by Council Member Zappone, seconded by Council Member Klitzke, to adopt the Zappone/Dillon/Klitzke proposed amendments to Ordinance C36556—relating to the Center and Corridor and parking development regulations—as filed July 12, 2024; **carried 6-1.**

**Ordinance C36534 (As Amended and Passed by City Council on July 8, 2024)
(Council Sponsors: Council Members Dillon and Klitzke)**

Motion by Council Member Dillon, seconded by Council Member Bingle, **to reconsider** Ordinance C36534 titled “Gun Violence Prevention for a Safer Spokane” as a final reading on July 22; **carried 7-0.**

Action to Approve July 22, 2024, Advance Agenda

Following staff reports and Council inquiry and discussion regarding the July 22, 2024, Advance Agenda items, the City Council took the following action (pursuant to Council Rule 2.1.B):

Motion by Council Member Klitzke, seconded by Council Member Dillon, **to approve** the July 22, 2024, Advance Agenda (as amended); **carried 7-0.**

Council Recess/Executive Session

The City Council recessed at 4:41 p.m. No Executive Session was held. The City Council reconvened at 6:02 p.m. for the Legislative Session.

LEGISLATIVE SESSION

Land Acknowledgement

Council President Wilkerson started the meeting off by reading the “Land Acknowledgement” (adopted by City Council on March 22, 2021, under Resolution 2021-0019) which appears on page 2 of the agenda.

Pledge of Allegiance

The Pledge of Allegiance was led by Council President Wilkerson.

Roll Call

On roll call, Council President Wilkerson and Council Members Bingle, Cathcart, Dillon, Klitzke, Navarrete, and Zappone were present.

Giacobbe Byrd, Director-City Council Office; City Council Policy Advisor Chris Wright; and City Clerk Terri Pfister were also present for the meeting.

There were no **Mayoral Proclamations.**

There were no **Reports from Community Organizations.**

BOARDS AND COMMISSIONS APPOINTMENTS

Appointments to Arts Commission (CPR 1981-0043) and West Quadrant Project Advisory Committee (CPR 2007-0039)

Upon 7-0 Voice Vote, the City Council **approved** (and thereby confirmed) the following appointments:

- Appointment of Julie Shepard to the Arts Commission for a three-year term from July 15, 2024 to July 15, 2027.
- Appointment of Liz Marlin to the West Quadrant Project Advisory Committee as the West Central Alternate Position for a three-year term from July 8, 2024, to July 8, 2027.
- Appointment of Wende Wilbur to the West Quadrant Project Advisory Committee as the At-Large Primary Position for a three-year term from July 8, 2024, to July 8, 2027.

CONSENT AGENDA

After public testimony and Council commentary, the following action was taken:

Upon 7-0 Voice Vote, the City Council **approved** Staff Recommendations for the following items; **carried 7-0**:

Purchase from Tiercel Technology (Princeton, Ontario, Canada) of conveyor belt skirting for use at the Waste to Energy Facility—\$61,690.60 (incl. tax and shipping). (OPR 2024-0550 / RFQ 6140-24) (Council Sponsors: Council President Wilkerson and Council Members Bingle and Klitzke)

Lease extension with Kenworth Sales (Spokane) for a semitruck utilized at the Waste to Energy Facility from April 1, 2024, through September 30, 2024—additional \$35,277.02 (plus tax). Total Annual Cost: \$71,927.04. (OPR 2023-0385) (Council Sponsors: Council President Wilkerson and Council Members Bingle and Klitzke)

Contract Amendment with Gerard Chimney Company (St. Louis, MO) for stack repairs and inspection at the Waste to Energy Facility from April 1, 2024, through December 31, 2024—additional \$275,000. Total Cost: \$500,000 (plus tax). (OPR 2024-0244 / PW ITB 6028-23) (Council Sponsors: Council President Wilkerson and Council Members Bingle and Klitzke)

Consultant Agreement with HDR Engineering Inc. (Bellevue, WA) for cost estimation and engineering support services at the Waste to Energy Facility from July 1, 2024, through June 30, 2025—not to exceed \$70,026 (plus tax, if applicable). (OPR 2024-0551 / A&E 24-01) (Council Sponsors: Council President Wilkerson and Council Members Bingle and Klitzke)

Contract with Loomis Armored US, LLC (Houston TX) for armored car services from May 23, 2024, through May 22, 2026—\$65,000 annually. (OPR 2024-0552) (Council Sponsors: Council President Wilkerson and Council Members Cathcart and Zappone)

Report of the Mayor of pending:

- a. Claims and payments of previously approved obligations, including those of Parks and Library, through July 5, 2024, total \$7,279,442.52 (Check Nos.: 604047-604182; Credit Card Nos.: 000337-000374; ACH Nos.: 130957-131209), with Parks and Library claims approved by their respective boards. Warrants excluding Parks and Library total \$6,377,924.53. (CPR 2024-0002)
- b. Payroll claims of previously approved obligations through July 6, 2024: \$10,365,403.95 (Check Nos.: 573190-573466). (CPR 2024-0003)

City Council Meeting Minutes: June 24, June 27, and July 11, 2024. (CPR 2024-0013)

Amendment to Agreement with Spokane County Sheriff's Office in conjunction with the Mental Health Field Response Team Fiscal Year 2023 Grant Program from July 1, 2023, through June 30, 2025, to accept additional funding to be used to retroactively fund two full-time Spokane Police Department employees from July 1, 2023, through June 30, 2024—additional \$447,093. Total award: \$1,833,259. (OPR 2024-0064) (As added during the 3:30 p.m. Briefing Session) (Council Sponsors: Council Members Cathcart, Dillon, and Navarrete)

LEGISLATIVE AGENDA

There were no **Special Budget Ordinances**.

There were no **Emergency Ordinances**.

RESOLUTIONS

For Council action on Resolution 2024-0065, see section of minutes under 3:30 p.m. Briefing Session.

FINAL READING ORDINANCES

For Council action on Final Reading Ordinance C36120, see section of minutes under 3:30 p.m. Briefing Session.

There were no **First Reading Ordinances**.

SPECIAL CONSIDERATIONS

Council Letter to Governor Inslee regarding SB 6175 (CPR 2024-0016) (as amended during the 3:30 p.m. Briefing Session) (Council Sponsor: Council Member Cathcart)

After receiving an overview of the letter by Council Member Cathcart, public testimony, and Council commentary, the following action was taken:

Upon 7-0 Voice Vote, the City Council **approved** the City Council letter to Governor Inslee, as amended, to direct the Department of Revenue to expedite the rulemaking process and publish finalized rules implementing SB 6175 before the end of this year.

Ayes: Bingle, Cathcart, Dillon, Klitzke, Navarrete, Wilkerson, and Zappone
Nays: None
Abstain: None
Absent: None

HEARINGS

Hearing on Emergency Ordinance C36522, passed by City Council on May 20, 2024 (Council Sponsors: Council Members Dillon and Navarrete)

The City Council held a hearing on Emergency Ordinance C36522, passed by City Council on May 20, 2024, imposing an immediate one-year moratorium on new preliminary subdivision and short subdivision applications in the Latah/Hangman and Grandview/Thorpe Neighborhoods. After public testimony and Council commentary, the following action was taken:

Motion by Council Member Zappone, seconded by Council Member Klitzke, **to close** the hearing and adopt the findings in Ordinance C36522; **carried 5-2.**

Ayes: Dillon, Klitzke, Navarrete, Wilkerson, and Zappone
Nos: Bingle and Cathcart
Abstain: None
Absent: None

[The City Clerk left the meeting at 6:47 p.m. (pursuant to Council Rule 2.2.A). Open Forum speaker information and motion of adjournment and adjournment time were provided by Council Director Giacobbe Byrd for the minutes.]

OPEN FORUM

Council President Wilkerson reviewed the rules of decorum for open forum. The following individual(s) spoke during the Open Forum:

- Will Hulings
- Reed Jessen
- Justin Haller
- Dennis Flynn
- Larry Andrews
- Sunshine Wiggins
- Jack Talcott
- Andrea
- Dave Bilslund
- Eugene Knowles
- Cherrie Barnett

ADJOURNMENT

Motion by Council Member Klitzke, seconded by Council Member Zappone, to adjourn; **carried 7-0.**

There being no further business to come before the City Council, the meeting adjourned at 7:08 p.m.

Minutes prepared and submitted for publication in the July 24, 2024, issue of the *Official Gazette*.

Terri Pfister
City Clerk

Approved by Spokane City Council on August 12, 2024.

Betsy Wilkerson
City Council President

Attest:

Terri Pfister
City Clerk

MINUTES OF SPOKANE CITY COUNCIL

Monday, July 22, 2024

BRIEFING SESSION

The Briefing Session of the Spokane City Council held on the above date was called to order at 3:30 p.m. in the Council Chambers in the Lower Level of the Municipal Building, 808 West Spokane Falls Boulevard, Spokane, Washington.

Roll Call

On roll call, Council President Wilkerson and Council Members Bingle, Cathcart, Dillon, Klitzke, Navarrete, and Zappone were present.

Interim City Administrator Garrett Jones, City Attorney; Giacobbe Byrd, Director-City Council Office; City Council Policy Advisor Chris Wright; and City Clerk Terri Pfister were also present for the meeting.

Current Agenda Review

The City Council reviewed the July 22, 2024, Current Agenda.

Memorandums of Understanding regarding Salary Savings Plans (OPR 2024-0553 and OPR 2024-0562) (Council Sponsors: Council President Wilkerson and Council Members Dillon and Cathcart)

Motion by Council Member Klitzke, seconded by Council Member Dillon, **to reconsider** the Memorandums of Understanding with the Spokane Police Guild (OPR 2024-0553) and the Spokane Police Lieutenants & Captains Association (OPR 2024-0562) regarding Salary Savings Plans; **carried 7-0.**

Motion by Council Member Klitzke, seconded by Council Member Zappone, **to suspend** Council Rules for the purpose of adding the Memorandums of Understanding with the Spokane Police Guild (OPR 2024-0553) and the Spokane Police Lieutenants & Captains Association (OPR 2024-0562) regarding Salary Savings Plans to the Consent Agenda; **carried 7-0.**

Motion by Council Member Klitzke, seconded by Council Member Dillon, **to adopt** the Klitzke Proposed Amendments to the Memorandums of Understanding with the Spokane Police Guild (OPR 2024-05F53) and the Spokane Police Lieutenants & Captains Association (OPR 2024-0562) regarding Salary Savings Plans, filed July 29, 2024; **carried 7-0.**

Resolution 2024-0062 (Deferred from July 8, 2024, Agenda) (Council Sponsors: Council President Wilkerson and Council Members Zappone and Klitzke)

Motion by Council Member Zappone, seconded by Council Member Klitzke, **to adopt** the Zappone Proposed Amendment to Resolution 2024-0062—relating to the Traffic Calming Fund requesting the mayor use current funding to establish a Sidewalk Improvement and Repair Pilot Program—filed July 19, 2024; **carried 7-0.**

Resolution 2024-0067 (Council Sponsors: Council President Wilkerson and Council Member Dillon)

Motion by Council Member Zappone, seconded by Council Member Klitzke, **to adopt** the Wilkerson Proposed Amendment to Resolution 2024-0067—providing for the submission to the qualified electors of the City of Spokane at an election to be held on November 5, 2024 of a proposition authorizing an increase to the sales and use tax in Spokane of one-tenth of one percent (0.1%) on the selling price to fund enhanced community safety; setting forth the text of the ballot proposition; directing proper city officials to take necessary actions; and providing for other properly related matters—filed July 19, 2024; **carried 7-0.**

Resolution 2024-0068 (Council Sponsors: Council President Wilkerson and Council Member Dillon)

Motion by Council Member Zappone, seconded by Council Member Klitzke, **to adopt** the Wilkerson Proposed Amendment to Resolution 2024-0068—regarding the appointment of for and against committee members relating to a Proposition No. 1 on the November 5, 2024, special election ballot concerning a proposition for funding enhanced community safety operations though an increase in the sales and use tax rate by one-tenth of one percent (0.1%)—filed July 19, 2024; **carried 7-0.**

Resolution 2024-0065 (Council Sponsors: Council President Wilkerson and Council Members Cathcart and Zappone)

Motion by Council Member Klitzke, seconded by Council Member Zappone, **to suspend** Council Rules for the purpose of considering the Wilkerson Proposed Amendment to Resolution 2024-0065—Joint Resolution of the Board of County Commissioners of Spokane County, Washington, the City Council of the City of Spokane, Washington, and the Spokane Airport Board authorizing Spokane County to issue its Airport Revenue Bonds to pay all or part of the cost of certain improvements to airport facilities; authorizing Spokane County to fix, by subsequent resolution, terms and covenants of such bonds; authorizing Spokane County to pledge or otherwise obligate the revenues of the airport; authorizing Spokane County to sell such bonds and to provide for the delivery thereof to the purchaser; and providing for other matters relating thereto—filed July 19, 2024; **carried 6-1.**

Motion by Council Member Klitzke, seconded by Council Member Zappone, **to adopt** the Wilkerson Proposed Amendment to Resolution 2024-0065—Joint Resolution of the Board of County Commissioners of Spokane County, Washington, the City Council of the City of Spokane, Washington, and the Spokane Airport Board authorizing Spokane County to issue its Airport Revenue Bonds to pay all or part of the cost of certain improvements to airport facilities; authorizing Spokane County to fix, by subsequent resolution, terms and covenants of such bonds; authorizing Spokane County to pledge or

otherwise obligate the revenues of the airport; authorizing Spokane County to sell such bonds and to provide for the delivery thereof to the purchaser; and providing for other matters relating thereto—filed July 19, 2024; **carried 7-0.**

Final Reading Ordinance C36534 (Brought back for reconsideration by action of Council during its July 15, 2024, 3:30 p.m. Briefing Session) (Council Sponsors: Council Members Dillon and Klitzke)

Motion by Council Member Dillon, seconded by Council Member Klitzke, **to adopt** the Dillon Proposed Amendment to Final Reading Ordinance C36534—titled “Gun Violence Prevention for a Safer Spokane,” relating to the establishment provisions relating to firearms safety and prevention—**carried 6-1.**

Resolution 2024-0070 (Council Sponsors: Council Members Bingle and Cathcart)

Motion by Council Member Zappone, seconded by Council Member Klitzke, **to defer indefinitely** Resolution 2024-0070 of the City of Spokane, Washington, urging the enforcement of the City’s ordinances prohibiting unlawful camping and occupation in public areas following the recent U.S. Supreme Court decision on *Grants Pass v. Johnson*; **carried 4-3.**

Action to Approve July 22, 2024, Current Agenda (as amended)

Following staff reports and Council inquiry and discussion regarding the July 22, 2024, Current Agenda items, the City Council took the following action (pursuant to Council Rule 2.1.B):

Motion by Council Member Zappone, seconded by Council Member Klitzke, **to approve** the July 22, 2024, Current Agenda (as amended); **carried 6-1.**

Advance Agenda Review

There was no Advance Agenda review, as the July 29, 2024, City Council Meeting was canceled.

Council Recess/Executive Session

The City Council recessed at 4:11 p.m. No Executive Session was held. The City Council reconvened at 6:00 p.m. for the Legislative Session.

LEGISLATIVE SESSION

Land Acknowledgement

Council President Wilkerson started the meeting off by reading the “Land Acknowledgement” (adopted by City Council on March 22, 2021, under Resolution 2021-0019) which appears on page 2 of the agenda.

Pledge of Allegiance

The Pledge of Allegiance was led by Council President Wilkerson.

Roll Call

On roll call, Council President Wilkerson and Council Members Bingle, Cathcart, Dillon, Klitzke, Navarrete, and Zappone were present.

Giacobbe Byrd, Director-City Council Office; City Council Policy Advisor Chris Wright; and City Clerk Terri Pfister were also present for the meeting.

There were no **Mayoral Proclamations**.

There were no **Reports from Community Organizations**.

There were no **Boards and Commissions Appointments**.

CONSENT AGENDA

After public testimony and an opportunity for Council commentary, the following action was taken:

Upon 7-0 Voice Vote, the City Council **approved** Staff Recommendations for the following items:

Purchases of soft body armor and ballistic helmets for each riding position within the Spokane Fire Department Operations Division from:

- a. The Bunker (Spokane Valley, WA)—\$83,600.90 (incl. tax). (OPR 2024-0563)
- b. Galls (Spokane)—\$76,191 (incl. tax). (OPR 2024-0564)

(Council Sponsors: Council Members Dillon, Cathcart, and Navarrete)

Purchase from iT1 Source, LLC (Tempe, AZ) of Autel Dragonfish long-range drone for the Spokane Police Department—\$164,258.30. (OPR 2024-0565) (Council Sponsors: Council Members Dillon, Cathcart, and Navarrete)

Purchase from Carahsoft (Reston, VA) of LIMA cellular network scanner for the Spokane Police Department—\$119,560. (OPR 2024-0566) (Council Sponsors: Council Members Dillon, Cathcart, and Navarrete)

Contract with Forensic Logic, LLC (Freemont, CA) of on-line CrimeTracer software subscription with licensing, maintenance, and support for the Spokane Police Department from May 1, 2024, through April 30, 2025—\$57,475 (plus tax, if applicable). (OPR 2024-0567) (Council Sponsors: Council Members Cathcart, Dillon, and Navarrete)

Grant Agreement with the Washington Auto Theft Prevention Authority for procurement of automated license plate readers and associated public outreach campaigns for the Spokane Police Department from June 1, 2024, through June 30, 2025—\$150,000 Revenue. (OPR 2024-0568) (Relates to Special Budget Ordinance C36547) (Council Sponsors: Council Members Cathcart, Dillon, and Navarrete)

Interlocal Agreement with the Washington State Criminal Justice Training Commission outlining reimbursement process regarding expansion of the Spokane Police Academy's Training Center—\$1,400,000 Revenue. (OPR 2024-0569) (Council Sponsors: Council Members Cathcart, Dillon, and Navarrete)

Contract for a one-time grant allocation to the Single Family Rehabilitation program for the purpose of providing grants for home repairs to meet emergent community needs of low- and moderate-income homeowners—\$1,700,000. (OPR 2024-0570) (Council Sponsors: Council Members Zappone, Bingle, and Klitzke)

Recommendation to list the following on the Spokane Register of Historic Places:

- a. Mulligan-Brazeau House & Garage located at 511 W 13th Avenue. (CPR 2024-0571)
- b. Mack-Hayfield-Kane House, Garage, and Garden located at 734 E 23rd Avenue. (CPR 2024-0572)

(Council Sponsors: Council Members Zappone, Bingle, and Klitzke)

Contract with The Davenport Group USA, Ltd. (Crystal Lake, IL) for LAMA permitting and licensing system software and maintenance from August 1, 2024, through July 31, 2029—\$1,824,105.99 (incl. tax). (OPR 2024-0573 / RFP 6002-23) (Council Sponsors: Council Members Zappone, Bingle, and Klitzke)

Report of the Mayor of pending claims and payments of previously approved obligations, including those of Parks and Library, through July 12, 2024, total \$13,374,144.04 (Check Nos.: 604183-604310; Credit Card Nos.: 000375-000402; ACH Payment Nos.: 131210-131456), with Parks and Library claims approved by their respective boards. Warrants excluding Parks and Library total \$12,921,133.01. (CPR 2024-0002)

Minutes

- a. City Council Meeting Minutes: July 18, 2024. (CPR 2024-0013)

- b. City Council Public Safety and Community Health Standing Committee Meeting Minutes July 8, 2024. (CPR 2024-0018)

Memorandums of Understanding to offer voluntary retirement incentives to eligible members of the following groups as a Salary Savings Plan with:

- a. Spokane Police Guild. (OPR 2024-0553)
- b. Spokane Police Lieutenants & Captains Association. (OPR 2024-0562)
(As added and amended during the 3:30 p.m. Briefing Session) (Council Sponsors: Council President Wilkerson and Council Members Dillon and Cathcart)

LEGISLATIVE AGENDA

SPECIAL BUDGET ORDINANCES

Special Budget Ordinance C36545 (Council Sponsors: President Wilkerson and Council Members Cathcart and Zappone)

After an opportunity for public testimony and Council commentary, with none provided, the following action was taken:

Upon 5-2 Roll Call Vote, the City Council **passed Special Budget Ordinance C36545** amending Ordinance No. C36467 passed by the City Council November 27, 2023, and entitled, "An Ordinance adopting the Annual Budget of the City of Spokane for 2024, making appropriations to the various funds of the City of Spokane government for the fiscal year ending December 31, 2024, and providing it shall take effect immediately upon passage," and declaring an emergency and appropriating funds in:

Human Services Grants Fund

- 1) Increase revenue by \$9,100,203.
 - A) Of the increased revenue, \$9,100,203 is provided solely for grant revenue from the Department of Commerce.
- 2) Increase appropriation by \$9,100,203.
 - A) Of the increased appropriation, \$8,761,526 is provided solely for contractual services.
 - B) Of the increased appropriation, \$338,677 is provided solely for the City's administrative costs, including salaries, benefits, supplies, and equipment.

(This action arises from the award and acceptance of the Department of Commerce's supplemental operating budget grant funds.)

Ayes: Dillon, Klitzke, Navarrete, Wilkerson, and Zappone
Nos: Bingle and Cathcart
Abstain: None
Absent: None

Special Budget Ordinance C36546 (Council Sponsors: Council Members Zappone, Klitzke, and Bingle)

After public testimony and an opportunity for Council commentary, with none provided, the following action was taken:

Upon 5-2 Roll Call Vote, the City Council **passed Special Budget Ordinance C36546** amending Ordinance No. C36467 passed by the City Council November 27, 2023, and entitled, "An Ordinance adopting the Annual Budget of the City of Spokane for 2024, making appropriations to the various funds of the City of Spokane government for the fiscal year ending December 31, 2024, and providing it shall take effect immediately upon passage," and declaring an emergency and appropriating funds in:

HOME Program Grant Fund

1) Increase revenue by \$4,628,671

A) Of the increased revenue, \$4,628,671 is provided by the U.S. Department of Housing and Urban Development (HUD) as part of the HOME – American Rescue Plan (HOME-ARP) program.

2) Increase appropriation by \$4,628,671

A) Of the increased appropriation, \$4,207,883 is provided solely for contractual services to be provided by the City’s sub-recipients to deliver housing and housing-related services to the community.

B) Of the increased appropriation, \$260,398 is provided solely for salaries and benefits for the City of Spokane’s employees who will be administering the programs.

C) Of the increased appropriation, \$160,390 is provided solely for other supplies, services, and equipment required for the administration of the programs.

(This action arises from the need to accept and receive grant funding from HUD to provide housing and housing-related services for the citizens of Spokane.)

Ayes: Dillon, Klitzke, Navarrete, Wilkerson, and Zappone

Nos: Bingle and Cathcart

Abstain: None

Absent: None

Special Budget Ordinance C36547 (Relates to OPR 2024-0568 under the Consent Agenda) (Council Sponsors: Council Members Cathcart, Dillon, and Navarrete)

After an opportunity for public testimony and Council commentary, with none provided, the following action was taken:

Upon 7-0 Roll Call Vote, the City Council **passed Special Budget Ordinance C36547** amending Ordinance No. C36467 passed by the City Council

November 27, 2023, and entitled, "An Ordinance adopting the Annual Budget of the City of Spokane for 2024, making appropriations to the various funds of the City of Spokane government for the fiscal year ending December 31, 2024, and providing it shall take effect immediately upon passage," and declaring an emergency and appropriating funds in:

Public Safety and Judicial Grant Fund

1) Increase revenue by \$150,000.

A) Of the increased revenue, \$150,000 is provided by the Washington Auto Theft Prevention Authority (WATPA) through their Auto Theft Grant Program.

2) Increase appropriation by \$150,000.

A) Of the increased appropriation, \$125,000 is to be provided solely for equipment.

B) Of the increased appropriation, \$25,000 is to be provided solely for contractual services.

(This action arises from the need to accept grant funding from WATPA for the expansion of license plate reader technology.)

Ayes: Bingle, Cathcart, Dillon, Klitzke, Navarrete, Wilkerson, and Zappone

Nos: None

Abstain: None

Absent: None

There were no **Emergency Ordinances**.

RESOLUTIONS

Resolution 2024-0062 (As amended during the 3:30 p.m. Briefing Session) (Deferred from July 8, 2024, Agenda) (Council Sponsors: Council President Wilkerson and Council Members Zappone and Klitzke)

After public testimony and Council commentary, the following action was taken:

Upon 7-0 Roll Call Vote, the City Council **adopted Resolution 2024-0062** as amended, relating to the Traffic Calming Fund requesting the mayor use current funding to establish a Sidewalk Improvement and Repair Pilot Program.

Ayes: Bingle, Cathcart, Dillon, Klitzke, Navarrete, Wilkerson, and Zappone

Nos: None

Abstain: None

Absent: None

Resolution 2024-0066 (Relates to First Reading Ordinance C36548) (Council Sponsors: Council Members Zappone, Bingle, and Klitzke)

After public testimony and Council commentary, the following action was taken:

Upon 7-0 Roll Call Vote, the City Council **adopted Resolution 2024-0066** of intention to establish a sales and use tax deferral program.

Ayes: Bingle, Cathcart, Dillon, Klitzke, Navarrete, Wilkerson, and Zappone
Nos: None
Abstain: None
Absent: None

Resolution 2024-0067 (As amended during the 3:30 p.m. Briefing Session) (Council Sponsors: Council President Wilkerson and Council Member Dillon)

After public testimony and Council commentary, the following action was taken:

Upon 5-2 Roll Call Vote, the City Council **adopted Resolution 2024-0067**, as amended, providing for the submission to the qualified electors of the City of Spokane at an election to be held on November 5, 2024 of a proposition authorizing an increase to the sales and use tax in Spokane of one-tenth of one percent (0.1%) on the selling price to fund enhanced community safety; setting forth the text of the ballot proposition; directing proper city officials to take necessary actions; and providing for other properly related matters.

Ayes: Dillon, Klitzke, Navarrete, Wilkerson, and Zappone
Nos: Bingle and Cathcart
Abstain: None
Absent: None

Resolution 2024-0068 (As amended during the 3:30 p.m. Briefing Session) (Council Sponsors: Council President Wilkerson and Council Member Dillon)

After public testimony and Council commentary, the following action was taken:

Upon 7-0 Roll Call Vote, the City Council **adopted Resolution 2024-0068**, as amended, regarding the appointment of for and against committee members relating to a Proposition No. 1 on the November 5, 2024, special election ballot concerning a proposition for funding enhanced community safety operations through an increase in the sales and use tax rate by one-tenth of one percent (0.1%).

Ayes: Bingle, Cathcart, Dillon, Klitzke, Navarrete, Wilkerson, and Zappone
Nos: None
Abstain: None

Absent: None

Resolution 2024-0069 (Council Sponsors: Council President Wilkerson and Council Member Dillon)

After an opportunity for public testimony, with none provided, and Council commentary, the following action was taken:

Upon 7-0 Roll Call Vote, the City Council **adopted Resolution 2024-0069** approving an extension of the appointment of Justin Lundgren as the interim police chief for the City of Spokane.

Ayes: Bingle, Cathcart, Dillon, Klitzke, Navarrete, Wilkerson, and Zappone
Nos: None
Abstain: None
Absent: None

For Council action on Resolution 2024-0070, see section of minutes under 3:30 p.m. Briefing Session.

Resolution 2024-0071 (Council Sponsors: Council President Wilkerson and Council Members Bingle and Klitzke)

After an opportunity for public testimony, with none provided, and Council commentary, the following action was taken:

Upon 7-0 Roll Call Vote, the City Council **adopted Resolution 2024-0071** approving an extension of the appointment of Michael Sloon as the interim Chief Innovation Officer for the City of Spokane.

Ayes: Bingle, Cathcart, Dillon, Klitzke, Navarrete, Wilkerson, and Zappone
Nos: None
Abstain: None
Absent: None

Resolution 2024-0072 (Council Sponsors: Council President Wilkerson and Council Members Bingle and Klitzke)

After an opportunity for public testimony, with none provided, and Council commentary, the following action was taken:

Upon 7-0 Roll Call Vote, the City Council **adopted Resolution 2024-0072** approving an extension of the appointment of Jason Conley as the interim Director of Spokane Parks and Recreation for the City of Spokane.

Ayes: Bingle, Cathcart, Dillon, Klitzke, Navarrete, Wilkerson, and Zappone

Nos: None
Abstain: None
Absent: None

Resolution 2024-0065 (As amended during the 3:30 p.m. Briefing Session) (Deferred from July 15, 2024, Agenda) (Council Sponsors: Council President Wilkerson and Council Members Cathcart and Zappone)

After public testimony and Council commentary, the following action was taken:

Upon 7-0 Roll Call Vote, the City Council **adopted Resolution 2024-0065**, as amended, a Joint Resolution of the Board of County Commissioners of Spokane County, Washington, the City Council of the City of Spokane, Washington, and the Spokane Airport Board authorizing Spokane County to issue its Airport Revenue Bonds to pay all or part of the cost of certain improvements to airport facilities; authorizing Spokane County to fix, by subsequent resolution, terms and covenants of such bonds; authorizing Spokane County to pledge or otherwise obligate the revenues of the airport; authorizing Spokane County to sell such bonds and to provide for the delivery thereof to the purchaser; and providing for other matters relating thereto.

Ayes: Bingle, Cathcart, Dillon, Klitzke, Navarrete, Wilkerson, and Zappone
Nos: None
Abstain: None
Absent: None

FINAL READING ORDINANCES

Final Reading Ordinance C36534 (As amended and passed on July 8, 2024) (As further amended during the 3:30 p.m. Briefing Session – see above) (Brought back for reconsideration by action of Council during its July 15, 2024, 3:30 p.m. Briefing Session) (Council Sponsors: Council Members Dillon and Klitzke)

After public testimony and Council commentary, the following action was taken:

Upon 5-2 Roll Call Vote, the City Council **passed Final Reading Ordinance C36534**, as amended, Titled “Gun Violence Prevention for a Safer Spokane,” relating to the establishment provisions relating to firearms safety and prevention; adopting a new Chapter 10.75 to Title 10 of the Spokane Municipal Code, and repealing Section 12.05.065 of the Spokane Municipal Code.

Ayes: Dillon, Klitzke, Navarrete, Wilkerson, and Zappone
Nos: Bingle and Cathcart
Abstain: None
Absent: None

FIRST READING ORDINANCES

The following Ordinances were read for the first time, with further action deferred. Public testimony was received on the First Reading Ordinance.

- ORD C36548** Relating to the establishment of a sales and use tax deferral program for affordable housing; retitling chapter 08.07D of the Spokane Municipal Code (SMC); and enacting a new chapter 08.07E to Title 08 of the SMC. (Relates to Resolution 2024-0066) (Council Sponsors: Council Members Zappone, Bingle, and Klitzke)
- ORD C36549** Relating to the human rights and basic dignity of individuals experiencing homelessness; amending sections 9.02.050, 18.01.010, 18.01.020, and 18.01.030 of the Spokane Municipal Code; and enacting a new Section 18.05.040 of the Spokane Municipal Code. (Council Sponsors: Council Members Navarrete and Klitzke)
- ORD C36550** Amending Ordinance C26051 that vacated Thirteenth Avenue and Woodland Boulevard from the southeast right of way line of I-90 to the west line of "A" Street, Evergreen Drive from the southeast right of way line of I-90 to the north line of Fourteenth Avenue and the unnamed strip of land south of Lot 12 and north of Lots 17, 18, and 19, Block 16, Woodland Heights Addition, from the west line of Evergreen Drive to the extended west line of said Lots 12 and 17, and providing for an effective date. (Council Sponsors: Council Members Zappone and Klitzke)
- ORD C36551** Amending Ordinance C22045 that vacated "C" Street from the north line of Sixteenth Avenue to the south line of Fourteenth Avenue and Fifteenth Avenue from the east line of "C" Street to a line drawn parallel to and 330 feet east of the east line of "C" Street, in the City and County of Spokane, Washington, and providing for the effective date of this ordinance. (Council Sponsors: Council Members Zappone and Klitzke)
- ORD C36552** Relating to maximum residential heights and multi-unit open space standards amending Spokane Municipal Code (SMC) Sections 17C.111.205 and 17C.111.420. (Council Sponsors: Council Members Zappone, Klitzke, and Bingle)
- ORD C36553** Relating to the Hamilton Form-Based Code amending Spokane Municipal Code (SMC) Chapter 17C.123 Form Based Code Zones. (Council Sponsors: Council Members Zappone, Klitzke, and Bingle)
- ORD C36554** Relating to streamlining and expediting the land use review and approval process by relying on the Final Environmental Impact Statement (FEIS) for the South Logan Transit-Oriented Development (TOD) Plan by

adopting a Planned Action; implementing the intent of the recently adopted by resolution South Logan TOD Plan; adopting Spokane Municipal Code (SMC) Chapter 17C.420; and amending Spokane Municipal Code (SMC) Chapter 17A.020. (Council Sponsors: Council Members Zappone, Klitzke, and Bingle)

ORD C36555 Relating to height and height transition standards amending Spokane Municipal Code (SMC) Sections 17C.111.230 and 17C.120.220. (Council Sponsors: Council Members Zappone, Klitzke, and Bingle)

ORD C36556 Relating to the Center and Corridor and parking development regulations amending Spokane Municipal Code (SMC) Sections 17C.122.070, 17C.122.090, 17C.230.120, 17C.230.130, and 17C.300.130, repealing Sections 17C.122.080, 17C.122.100, 17C.122.110, and 17C.122T, and adopting new Sections 17C.122.200, 17C.122.210, 17C.122.220, 17C.122.230, 17C.122.240, and 17C.122.250. (As amended during the July 15, 2024, 3:30 p.m. Briefing Session) (Council Sponsors: Council Members Zappone, Klitzke, and Bingle)

There were no **Special Considerations**.

There were no **Hearings**.

[The City Clerk left the meeting at 8:14 p.m. (pursuant to Council Rule 2.2.A). Open Forum speaker information and motion of adjournment and adjournment time were provided by Council Director Giacobbe Byrd for the minutes.]

OPEN FORUM

The following individual(s) spoke during the Open Forum:

- Will Hulings
- Andrew Rolwes
- Rick Bocook
- Justin Haller
- Luis Manriquez
- Michael Lewis Arthur Meyer
- Eugene Knowles
- Cherrie Barnett

ADJOURNMENT

Motion by Council Member Bingle, seconded by Council Member Zappone, **to adjourn; carried 7-0.**

There being no further business to come before the City Council, the meeting adjourned at 8:34 p.m.

Minutes prepared by City Clerk Terri Pfister and submitted for publication in the August 7, 2024, issue of the *Official Gazette*.

Approved by Spokane City Council on August 12, 2024.

Betsy Wilkerson
City Council President

Attest:

Terri Pfister
City Clerk

STANDING COMMITTEE MINUTES
City of Spokane
Finance and Administration Committee
City Council Chambers
July 22, 2024

Call to Order: 1:17PM

Recording of the meeting may be viewed here: <https://vimeo.com/988600371>

Attendance

Committee Members Present:

Council Member Michael Cathcart (Chair), Council President Wilkerson, Council Member Zack Zappone, Council Member Bingle, Council Member Paul Dillon (arrived 1:29PM), Council Member Kitty Klitzke, Council Member Lili Navarrete

Staff/Others Present:

Giacobbe Byrd, Chris Wright, Shae Blackwell, Adam McDaniel, Arielle Anderson, Alex Gibilisco, Kate Fairborn, Dave Steel, Andres Grageda, Conner Thorne

Approval of Minutes

- No action taken

Agenda Items

Discussion items

1. Community Assembly Resolutions
 - Action taken
Presentation and Discussion only.
2. Quarter 2 2024 Investment Report
 - Action taken
Presentation and Discussion only.
3. Ordinance Repealing Inactive Funds (Code Clean-up)
 - Action taken
Discussion and approval to forward to Council for consideration. Sponsors: Cathcart, Wilkerson
4. Approval for Health Care Authority Contract-Pilot Street Medicine
 - Action taken
Discussion and approval to forward to Council for consideration. Sponsors: Zappone, Bingle, Klitzke

5. Ordinance Amending SERS Board Membership
 - Action taken
Discussion and approval to forward to Council for consideration. Sponsors: Cathcart, Wilkerson, Zappone
6. Keeping Families Together Resolution
 - Action taken
Discussion and approval to forward to Council for consideration. Sponsors: Navarrete, Wilkerson
7. Council Confirmation of Mayoral Appointment – Retirement Director
 - Action taken
Discussion and approval to forward to Council for consideration. Sponsors: Cathcart, Wilkerson, Zappone
8. Council Confirmation of Mayoral Appointment – Director of Info. & Technology
 - Action taken
Discussion and approval to forward to Council for consideration. Sponsors: Cathcart, Wilkerson, Zappone
9. Boards, Commission, and Initiatives Update
 - Action taken
Information sharing and discussion only.

Consent items

1. Value Blanket with Pomp's Tire (Contracts & Purchasing)
2. Community Minded Enterprise Contract Amendment (Accounting & Grants)
3. Contract with Gartner, Inc. (Finance, Treasury & Admin)
4. 5-year Lease of Riso Comcolor 9730 Printer for the Mail Center (Information Technology)
5. Contract Amendment for Conveyor Belt Services (Solid Waste Disposal)
6. Hoffman Well Station Roof Replacement Masonry Repairs (Facilities Management)
7. Innovia Contract Amendment (Accounting & Grants)
8. Numerica Credit Union Contract Amendment (Accounting & Grants)
9. Outside Counsel Contract Amendment (City Attorney)
10. 5-year Lease of Mail and Inserter Machines with Softwares (Information Technology)
11. Master Service Contract With Pomp's Tire (Contracts & Purchasing)

Executive session

None.

Adjournment

The meeting adjourned at 2:19PM

Minutes prepared and submitted for publication in the July 31, 2024, issue of the Official Gazette.

Shae Blackwell, Legislative Assistant

Approved by City Council on August 12, 2024.

Betsy Wilkerson
City Council President

Attest:

Terri L. Pfister
City Clerk

**Agenda Sheet for City Council:****Committee:** PIES **Date:** 07/15/2024**Committee Agenda type:** Discussion**Date Rec'd**

7/15/2024

Clerk's File #

RES 2024-0073

Cross Ref #**Project #****Council Meeting Date:** 08/12/2024**Submitting Dept**

PUBLIC WORKS

Bid #**Contact Name/Phone**

MARLENE FEIST 625-6505

Requisition #**Contact E-Mail**

MFEIST@SPOKANECITY.ORG

Agenda Item Type

Resolutions

Council Sponsor(s)

BWILKERSON JBINGLE KKLITZKE

Agenda Item Name

5200 – RESOLUTION FOR 2024 RETAIL WATER SERVICE AREA AMENDMENTS

Agenda Wording

RESOLUTION relating to modification of the City's Retail Water Service Area (RWSA) to amend the RWSA boundaries to include areas within the current Spokane County Urban Growth Area (UGA) boundaries and authorizing amendment of the City's RWSA map.

Summary (Background)

The City periodically modifies the retail water service boundaries and consistently has approved water service requests within the Spokane County Urban Growth Area (UGA). To promote operational and administrative efficiency, the Retail Water Service boundaries should be consistent with the UGA boundaries.

Lease? NO Grant related? NO Public Works? NO

Fiscal Impact

Approved in Current Year Budget? N/A

Total Cost \$

Current Year Cost \$

Subsequent Year(s) Cost \$

Narrative**Amount****Budget Account**

Select \$ #

Select \$ #

Select \$ #

Select \$ #

\$ #

\$ #



Continuation of Wording, Summary, Approvals, and Distribution

Agenda Wording

Summary (Background)

Approvals

Dept Head

MILLER, KATHERINE E

Division Director

FEIST, MARLENE

Accounting Manager

ALBIN-MOORE, ANGELA

Legal

SCHOEDEL, ELIZABETH

For the Mayor

JONES, GARRETT

Additional Approvals

Distribution List

jrhall@spokanecity.org

eraea@spokanecity.org

mfeist@spokanecity.org

publicworksaccounting@spokanecity.org

eschoedel@spokanecity.org

Committee Agenda Sheet

Public Infrastructure, Environment & Sustainability Committee

Committee Date	July 15, 2024
Submitting Department	Public Works
Contact Name	Marlene Feist, Elizabeth Schoedel
Contact Email & Phone	mfeist@spokanecity.org , eschoedel@spokanecity.org
Council Sponsor(s)	Wilkerson, Bingle, Klitzke
Select Agenda Item Type	<input type="checkbox"/> Consent <input checked="" type="checkbox"/> Discussion Time Requested: 10 min
Agenda Item Name	Resolution 2024 RWSA Amendments UGA
Proposed Council Action	<input checked="" type="checkbox"/> Approval to proceed to Legislative Agenda <input type="checkbox"/> Information Only
Summary (Background)	<p>The City’s Comprehensive Water System Plan (CWSP) on file with the Department of Health defines existing water service areas, retail water service areas, and future water service areas. The City periodically modifies the retail water service boundaries and consistently has approved water service requests within the Spokane County Urban Growth Area (UGA). To promote operational and administrative efficiency, the Retail Water Service boundaries should be consistent with the UGA boundaries. The attached resolution includes exhibit A to map all the existing UGA areas. Over time as the UGA areas are added, the intent would be to match those areas with the retail water service area once the new UGA area has been approved and after any challenge period has ended.</p>
*use the Fiscal Impact box below for relevant financial information	
Fiscal Impact	
Approved in current year budget? <input type="checkbox"/> Yes <input type="checkbox"/> No <input checked="" type="checkbox"/> N/A Total Cost: Click or tap here to enter text. Current year cost: Subsequent year(s) cost:	
Narrative: Please provide financial due diligence review, as applicable, such as number and type of positions, grant match requirements, summary type details (personnel, maintenance and supplies, capital, revenue), impact on rates, fees, or future shared revenue	
Funding Source <input type="checkbox"/> One-time <input type="checkbox"/> Recurring <input checked="" type="checkbox"/> N/A Specify funding source: Select Funding Source* Is this funding source sustainable for future years, months, etc? Click or tap here to enter text.	
Expense Occurrence <input type="checkbox"/> One-time <input type="checkbox"/> Recurring <input checked="" type="checkbox"/> N/A Other budget impacts: (revenue generating, match requirements, etc.)	
Operations Impacts (If N/A, please give a brief description as to why)	
<ul style="list-style-type: none"> • What impacts would the proposal have on historically excluded communities? 	

Public works services and projects are designed to serve all citizens and businesses. We strive to offer a consistent level of service to all, to distribute public investment throughout the community and to respond to gaps in services identified in various City plans.

- How will data be collected, analyzed, and reported concerning the effect of the program/policy by racial, ethnic, gender identity, national origin, income level, disability, sexual orientation, or other existing disparities?

N/A

- How will data be collected regarding the effectiveness of this program, policy, or product to ensure it is the right solution?

N/A

- Describe how this proposal aligns with current City Policies, including the Comprehensive Plan, Sustainability Action Plan, Capital Improvement Program, Neighborhood Master Plans, Council Resolutions, and others?

This resolution is consistent with the City's Water System Plan and long term Planning goals

Council Subcommittee Review

- Please provide a summary of council subcommittee review. If not reviewed by a council subcommittee, please explain why not.

City of Spokane Retail Service Area

Legend

- Retail Water Service Area
- Future Water Service Area
- Urban Growth Area
- Municipal Boundaries

By: ICM Date: February 2023

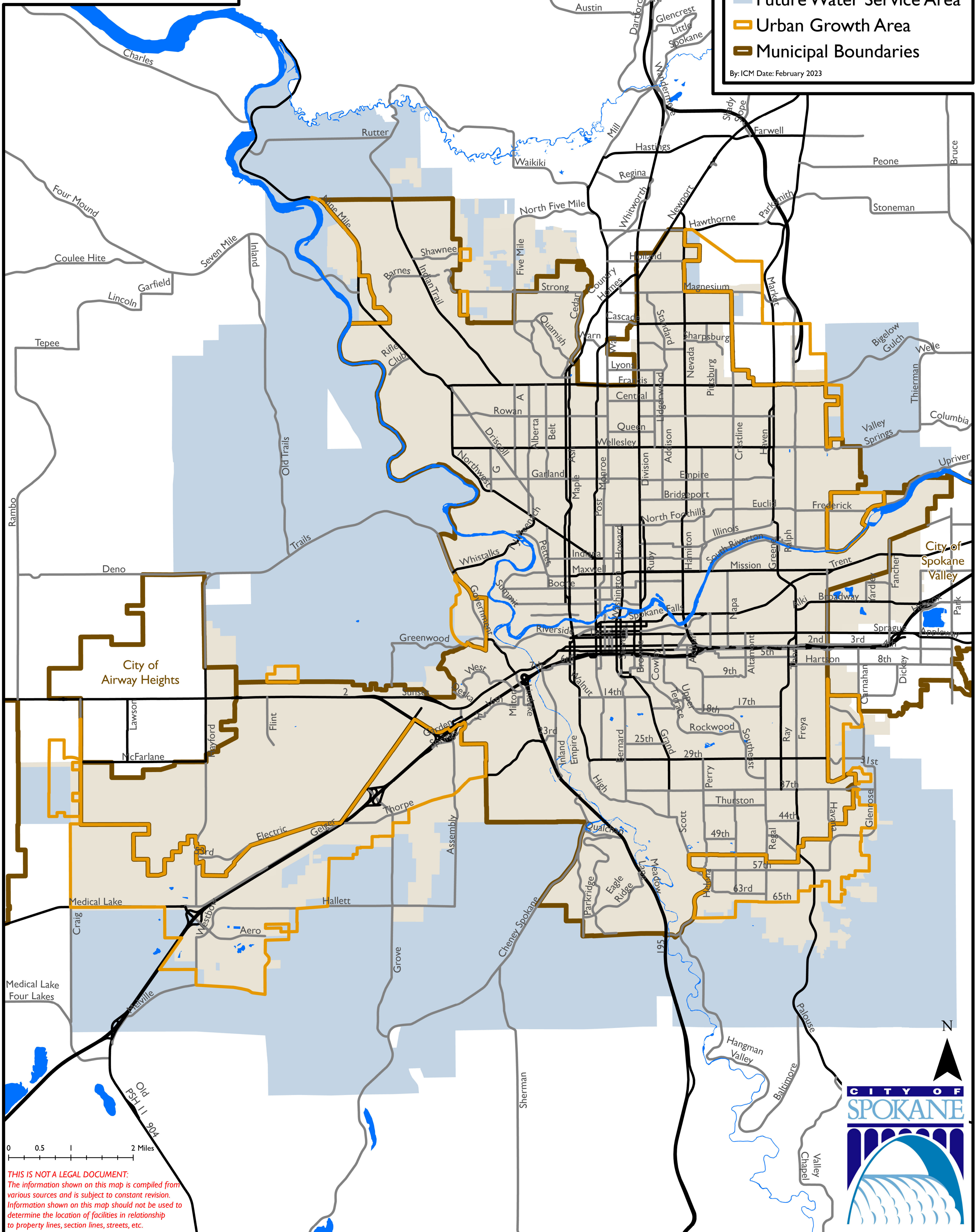

THIS IS NOT A LEGAL DOCUMENT.
 The information shown on this map is compiled from various sources and is subject to constant revision. Information shown on this map should not be used to determine the location of facilities in relationship to property lines, section lines, streets, etc.



RESOLUTION 2024-0073

A RESOLUTION relating to modification of the City of Spokane's Retail Water Service Area (RWSA) to amend the RWSA boundaries to include areas within the current Spokane County Urban Growth Area (UGA) boundaries and authorizing amendment of the City's RWSA map on file with the Washington State Department of Health.

WHEREAS, pursuant to the Washington State Department of Health Rules and Regulations, WAC 246-290-100, the City of Spokane is required to update its Comprehensive Water System Plan at least every ten years; and

WHEREAS, the City of Spokane's (City) Comprehensive Water System Plan (CWSP) pursuant to Washington State Department of Health rules and regulations defines existing water service areas, retail water service areas, and future water service areas; and

WHEREAS, within the CWSP, the City has a defined RWSA and Future Water Service Area (FWSA) within Spokane County; and

WHEREAS, the FWSA encompasses areas located inside and outside the UGA boundaries as defined under the state Growth Management Act; and

WHEREAS, the City's policy has consistently been to approve water service requests to serve those properties located within the UGA boundaries and outside the City's boundaries, all located within the City's Future Water Service Area; and

WHEREAS, in accordance the Spokane Municipal Code and to promote operational and administrative efficiency, the RWSA should be amended to be consistent with and mirror the UGA boundaries; and

WHEREAS, the Spokane City Council finds modification of the City's RWSA to include properties located within the defined UGA boundaries as reflected in the attached map, Exhibit "A" is in the public interest; and

WHEREAS, the Spokane City Council understands the UGA boundaries will change from time to time and understands the RWSA should mirror the final approved amendments to the UGA boundaries, approval only after any and all appeal timeframes have passed and any appeals have been resolved; --NOW, THEREFORE,

BE IT RESOLVED by the City of Spokane:

1) The amendment of the Retail Water Service Area Map is hereby approved and shall reflect the boundaries consistent with the current Spokane County Urban Growth Area boundaries as they exist as of this Resolution within the City's designated water service areas, and as may be amended from time to time following any and all appeal timeframes.

2) When the Urban Growth Area boundaries are expanded, any water requests shall be held in abeyance until such time as all appeals are finalized.

3) Staff is authorized to amend the City's Water Service Area map, as contained in the City's Comprehensive Water System Plan on file with the Washington State Department of Health consistent with this Resolution.

Adopted and approved by City Council _____, 2024.

City Clerk

Approved as to Form:

Assistant City Attorney



Agenda Sheet for City Council:

Committee: Finance & Administration **Date:** 07/22/2024

Committee Agenda type: Discussion

Date Rec'd

7/25/2024

Clerk's File #

RES 2024-0074

Cross Ref #

Project #

Council Meeting Date: 08/12/2024

Submitting Dept

CITY COUNCIL

Bid #

Contact Name/Phone

ANDRES 059-651-0855

Requisition #

Contact E-Mail

AGRAGEDA@SPOKANECITY.ORG

Agenda Item Type

Resolutions

Council Sponsor(s)

LNAVARRETE PDILLON KKLITZKE

Agenda Item Name

0320 - "KEEPING FAMILIES TOGETHER" RESOLUTION

Agenda Wording

A Resolution expressing support for the federal administration's new executive directive to keep immigrant and noncitizen families together, for local efforts to provide immigrant services, and for amending the City's federal legislative agenda to in

Summary (Background)

The Department of Homeland Security will implement a new process that would allow certain noncitizen spouses and children of U.S. citizens to apply for lawful permanent residence - status that they are already eligible for - without having to leave the country. The Spokane City Council officially endorses this executive directive.

Lease? NO Grant related? NO Public Works? NO

Fiscal Impact

Approved in Current Year Budget? N/A

Total Cost \$

Current Year Cost \$

Subsequent Year(s) Cost \$

Narrative

Amount

Budget Account

Neutral	\$	#
Select	\$	#
Select	\$	#
Select	\$	#
	\$	#
	\$	#

Committee Agenda Sheet

Finance & Administration Committee

Committee Date	07/22/2024
Submitting Department	City Council
Contact Name	Andres Grageda
Contact Email & Phone	agrageda@spokanecity.org (509)651-0855
Council Sponsor(s)	CM Navarrete
Select Agenda Item Type	<input type="checkbox"/> Consent <input checked="" type="checkbox"/> Discussion Time Requested: 5 min
Agenda Item Name	Keeping Families Together
Proposed Council Action	<input checked="" type="checkbox"/> Approval to proceed to Legislative Agenda <input type="checkbox"/> Information Only
Summary (Background)	<p>The Department of Homeland Security will implement a new process that would allow certain noncitizen spouses and children of U.S. citizens to apply for lawful permanent residence – status that they are already eligible for – without having to leave the country. The Spokane City Council officially endorses this executive directive.</p>
*use the Fiscal Impact box below for relevant financial information	

Fiscal Impact

Approved in current year budget? Yes No N/A

Total Cost: [Click or tap here to enter text.](#)

 Current year cost:

 Subsequent year(s) cost:

Narrative: Please provide financial due diligence review, as applicable, such as number and type of positions, grant match requirements, summary type details (personnel, maintenance and supplies, capital, revenue), impact on rates, fees, or future shared revenue

Funding Source One-time Recurring N/A

Specify funding source: Select Funding Source*

Is this funding source sustainable for future years, months, etc? [Click or tap here to enter text.](#)

Expense Occurrence One-time Recurring N/A

Other budget impacts: (revenue generating, match requirements, etc.)

Operations Impacts (If N/A, please give a brief description as to why)

- What impacts would the proposal have on historically excluded communities?

Noncitizens and undocumented immigrants have historically faced hardships in this country. Seeking employment, housing and other basic needs can be a challenge for these individuals and their families. This action makes it less burdensome to acquire legal status while keeping these

families united. The City of Spokane's endorsement shows that we support all of our residents, as the city's motto indicates.

- How will data be collected, analyzed, and reported concerning the effect of the program/policy by racial, ethnic, gender identity, national origin, income level, disability, sexual orientation, or other existing disparities?

Data can be collected by local organizations that provide support for immigrants. The data could inform us as to how many immigrants will be affected by this resolution.

- How will data be collected regarding the effectiveness of this program, policy, or product to ensure it is the right solution?

We can measure the effectiveness of the resolution by seeing if we achieve the goals of the resolution, including hosting informative town halls and support local organizations that provide legal assistance for immigrants.

- Describe how this proposal aligns with current City Policies, including the Comprehensive Plan, Sustainability Action Plan, Capital Improvement Program, Neighborhood Master Plans, Council Resolutions, and others?

This resolution aligns with the comprehensive plan, specifically chapter 10, which has to do with social health. The chapter discusses equitable funding, investments in social health, universal accessibility and cultural competency and education.

Council Subcommittee Review

- Please provide a summary of council subcommittee review. If not reviewed by a council subcommittee, please explain why not.

We did not have time to get a subcommittee review, but we will run the resolution by the SHRC and Equity Subcommittee in the next meetings.

RESOLUTION NO. 2024-0074

A Resolution expressing support for the federal administration's new executive directive to keep immigrant and noncitizen families together, for local efforts to provide immigrant services, and for amending the City's federal legislative agenda to include support for federal relief of immigrant legal services.

WHEREAS, the official motto of the City of Spokane is "In Spokane We All Belong," and

WHEREAS, the City of Spokane prioritizes and recognizes the value in keeping all families united; and

WHEREAS, the best outcomes for all families, and ultimately for the City of Spokane, arise when all members in our community, including noncitizens, are able to thrive and feel a sense of belonging that encourages them to participate in our civic and economic institutions; and

WHEREAS, on June 18, 2024, President Biden announced that the Department of Homeland Security will implement a new process that will help certain noncitizen spouses and children of U.S. citizens apply for lawful permanent residence – status that they are already eligible for – without leaving the country; and

WHEREAS, in order to be eligible, noncitizens must have resided in the United States for 10 or more years and be legally married to a U.S. citizen, while satisfying all applicable legal requirements; and

WHEREAS, eligible persons will be afforded a three-year period to apply for permanent residency, during which they will be allowed to remain with their families in the United States and be eligible for work authorization; and

WHEREAS, this new federal program will promote family unity and strengthen the national and local economy, thereby providing a significant benefit to the City of Spokane and helping U.S. citizens and their noncitizen family members stay together; and

WHEREAS, this federal program remove the fear and uncertainty these families face when one spouse is a United States citizen and the other is undocumented, and thereby benefit many noncitizens and their families in Spokane's increasingly diverse population; and

NOW, THEREFORE, BE IT RESOLVED by the City Council of the City of Spokane that it officially endorses the new policy articulated by the federal administration with respect to immigrant and noncitizen families; and

BE IT ALSO RESOLVED that the Spokane City Council recognizes the contributions of its noncitizen residents, including its immigrants and new arrivals; and

BE IT ALSO RESOLVED that the City Council adds federal relief for immigration legal assistance to its list of federal legislative priorities; and

BE IT ALSO RESOLVED that the City of Spokane commits to hosting town halls to understand and educate our community on issues relating to our immigrant population; and

BE IT ALSO RESOLVED that the City of Spokane will support the efforts of local organizations that work towards keeping noncitizen families together and achieving family unity; and

BE IT ALSO RESOLVED that the City of Spokane will support the efforts of local organizations that provide legal assistance for immigrants towards legal permanent residency and, eventually, citizenship.

Adopted by the City Council this ____ day of _____, 2024.

City Clerk

Approved as to form:

Assistant City Attorney

**Agenda Sheet for City Council:****Committee:** Finance & Administration **Date:** 07/22/2024**Committee Agenda type:** Discussion**Date Rec'd**

7/24/2024

Clerk's File #

RES 2024-0075

Cross Ref #**Project #****Council Meeting Date:** 08/12/2024**Submitting Dept**

MAYOR

Bid #**Contact Name/Phone**

ADAM 6779

Requisition #**Contact E-Mail**

AMCDANIEL@SPOKANECITY.ORG

Agenda Item Type

Resolutions

Council Sponsor(s)

MCATHCART BWILKERSON ZZAPPONE

Agenda Item Name

COUNCIL CONFIRMATION OF MAYORAL APPOINTEE – RETIREMENT DIR

Agenda Wording

Appointment of Christine Shisler as the Retirement Director for the City of Spokane.

Summary (Background)

Christine Shisler was appointed by Mayor Brown as the interim Retirement Director on February 6, 2024. Mayor Brown has selected Christine Shisler to be the permanent Retirement Director and is being presented for confirmation to City Council.

Lease? NO Grant related? NO Public Works? NO

Fiscal Impact

Approved in Current Year Budget? N/A

Total Cost \$

Current Year Cost \$

Subsequent Year(s) Cost \$

Narrative**Amount****Budget Account**

Select \$ #

Select \$ #

Select \$ #

Select \$ #

\$ #

\$ #



Continuation of Wording, Summary, Approvals, and Distribution

Agenda Wording

Summary (Background)

Approvals

Dept Head

JONES, GARRETT

Division Director

Accounting Manager

BUSTOS, KIM

Legal

SCHOEDEL, ELIZABETH

For the Mayor

PICCOLO, MIKE

Additional Approvals

Distribution List

amcdaniel@spokanecity.org

Committee Agenda Sheet

Finance & Administration Committee

Committee Date	7/22/2024
Submitting Department	Mayor's Office
Contact Name	Adam McDaniel
Contact Email & Phone	amcdaniel@spokanecity.org
Council Sponsor(s)	Please enter the name of the Council Sponsor(s)
Select Agenda Item Type	<input type="checkbox"/> Consent <input checked="" type="checkbox"/> Discussion Time Requested: 5
Agenda Item Name	Council Confirmation of Mayoral Appointee – Retirement Director
Proposed Council Action	<input checked="" type="checkbox"/> Approval to proceed to Legislative Agenda <input type="checkbox"/> Information Only
Summary (Background)	<p>Appointment of Christine Shisler as the Retirement Director for the City of Spokane.</p> <p>*use the Fiscal Impact box below for relevant financial information</p> <p>Christine Shisler was appointed by Mayor Brown as the interim Retirement Director on February 6, 2024. Mayor Brown has selected Christine Shisler to be the permanent Retirement Director and is being presented for confirmation to City Council.</p> <p>The SERS Board has concurred Christine Shisler's appointment as Retirement Director pursuant to SMC 03.01A.440.</p>
<p>Fiscal Impact</p> <p>Approved in current year budget? <input type="checkbox"/> Yes <input type="checkbox"/> No <input checked="" type="checkbox"/> N/A</p> <p>Total Cost: Click or tap here to enter text.</p> <p> Current year cost:</p> <p> Subsequent year(s) cost:</p> <p>Narrative: Please provide financial due diligence review, as applicable, such as number and type of positions, grant match requirements, summary type details (personnel, maintenance and supplies, capital, revenue), impact on rates, fees, or future shared revenue</p> <p>Funding Source <input type="checkbox"/> One-time <input type="checkbox"/> Recurring <input checked="" type="checkbox"/> N/A</p> <p>Specify funding source: Select Funding Source*</p> <p>Is this funding source sustainable for future years, months, etc? Click or tap here to enter text.</p> <p>Expense Occurrence <input type="checkbox"/> One-time <input type="checkbox"/> Recurring <input checked="" type="checkbox"/> N/A</p> <p>Other budget impacts: (revenue generating, match requirements, etc.)</p>	
Operations Impacts (If N/A, please give a brief description as to why)	
<p>What impacts would the proposal have on historically excluded communities?</p> <p><u>N/A</u></p>	
<p>How will data be collected, analyzed, and reported concerning the effect of the program/policy by racial, ethnic, gender identity, national origin, income level, disability, sexual orientation, or other existing disparities?</p> <p><u>N/A</u></p>	

How will data be collected regarding the effectiveness of this program, policy or product to ensure it is the right solution?

N/A

Describe how this proposal aligns with current City Policies, including the Comprehensive Plan, Sustainability Action Plan, Capital Improvement Program, Neighborhood Master Plans, Council Resolutions, and others?

N/A

RESOLUTION 2024 – 0075

A resolution approving the appointment of Christine Shisler as the Retirement Director for the City of Spokane.

WHEREAS, Section 24 of the City Charter provides that the Mayor shall have the power to appoint department heads subject to the approval of the City Council; and

WHEREAS, Section 2.14 F of the City Council Rules of Procedures states that approval of appointment of department heads shall be by resolution during the City Council's legislative session; and

WHEREAS, after full consideration, Mayor Lisa Brown has appointed Christine Shisler as the Retirement Director of the City of Spokane.

NOW, THEREFORE, BE IT RESOLVED by the City Council for the City of Spokane that it hereby approves the appointment of Christine Shisler as the Retirement Director for the City of Spokane.

ADOPTED BY THE CITY COUNCIL ON _____, 2024.

City Clerk

Approved as to form:

Assistant City Attorney

**Agenda Sheet for City Council:****Committee:** Finance & Administration **Date:** 07/22/2024**Committee Agenda type:** Discussion**Date Rec'd**

7/24/2024

Clerk's File #

RES 2024-0076

Cross Ref #**Project #****Council Meeting Date:** 08/12/2024**Submitting Dept**

MAYOR

Bid #**Contact Name/Phone**

ADAM 6779

Requisition #**Contact E-Mail**

AMCDANIEL@SPOKANECITY.ORG

Agenda Item Type

Resolutions

Council Sponsor(s)

MCATHCART BWILKERSON ZZAPPONE

Agenda Item Name

COUNCIL CONFIRMATION OF MAYORAL APPOINTEE – DIRECTOR OF INFO. &

Agenda Wording

Appointment of Laz Martinez as the Director of Information and Technology for the City of Spokane.

Summary (Background)

Laz Martinez was appointed by Mayor Brown as the interim Director of Information and Technology on January 1, 2024. Mayor Brown has selected Laz Martinez to be the permanent Director of Information and Technology and is being presented for confirmation to City Council.

Lease? NO

Grant related? NO

Public Works? NO

Fiscal Impact

Approved in Current Year Budget? N/A

Total Cost

\$

Current Year Cost

\$

Subsequent Year(s) Cost

\$

Narrative**Amount****Budget Account**

Select

\$

#

Select

\$

#

Select

\$

#

Select

\$

#

\$

#

\$

#



Continuation of Wording, Summary, Approvals, and Distribution

Agenda Wording

Summary (Background)

Approvals

Dept Head

JONES, GARRETT

Division Director

Accounting Manager

BUSTOS, KIM

Legal

SCHOEDEL, ELIZABETH

For the Mayor

PICCOLO, MIKE

Additional Approvals

Distribution List

amcdaniel@spokanecity.org

Committee Agenda Sheet

Finance & Administration Committee

Committee Date	7/22/2024
Submitting Department	Mayor's Office
Contact Name	Adam McDaniel
Contact Email & Phone	amcdaniel@spokanecity.org
Council Sponsor(s)	Please enter the name of the Council Sponsor(s)
Select Agenda Item Type	<input type="checkbox"/> Consent <input checked="" type="checkbox"/> Discussion Time Requested: 5
Agenda Item Name	Council Confirmation of Mayoral Appointee – Director of Information and Technology
Proposed Council Action	<input checked="" type="checkbox"/> Approval to proceed to Legislative Agenda <input type="checkbox"/> Information Only
Summary (Background)	<p>Appointment of Laz Martinez as the Director of Information and Technology for the City of Spokane.</p> <p>*use the Fiscal Impact box below for relevant financial information</p> <p>Laz Martinez was appointed by Mayor Brown as the interim Director of Information and Technology on January 1, 2024. Mayor Brown has selected Laz Martinez to be the permanent Director of Information and Technology and is being presented for confirmation to City Council.</p>
<p>Fiscal Impact</p> <p>Approved in current year budget? <input type="checkbox"/> Yes <input type="checkbox"/> No <input checked="" type="checkbox"/> N/A</p> <p>Total Cost: Click or tap here to enter text.</p> <p>Current year cost:</p> <p>Subsequent year(s) cost:</p> <p>Narrative: Please provide financial due diligence review, as applicable, such as number and type of positions, grant match requirements, summary type details (personnel, maintenance and supplies, capital, revenue), impact on rates, fees, or future shared revenue</p> <p>Funding Source <input type="checkbox"/> One-time <input type="checkbox"/> Recurring <input checked="" type="checkbox"/> N/A</p> <p>Specify funding source: Select Funding Source*</p> <p>Is this funding source sustainable for future years, months, etc? Click or tap here to enter text.</p> <p>Expense Occurrence <input type="checkbox"/> One-time <input type="checkbox"/> Recurring <input checked="" type="checkbox"/> N/A</p> <p>Other budget impacts: (revenue generating, match requirements, etc.)</p>	
Operations Impacts (If N/A, please give a brief description as to why)	
<p>What impacts would the proposal have on historically excluded communities?</p> <p><u>N/A</u></p>	
<p>How will data be collected, analyzed, and reported concerning the effect of the program/policy by racial, ethnic, gender identity, national origin, income level, disability, sexual orientation, or other existing disparities?</p> <p>N/A</p>	
<p>How will data be collected regarding the effectiveness of this program, policy or product to ensure it is the right solution?</p>	

N/A

Describe how this proposal aligns with current City Policies, including the Comprehensive Plan, Sustainability Action Plan, Capital Improvement Program, Neighborhood Master Plans, Council Resolutions, and others?

N/A

RESOLUTION 2024 – 0076

A resolution approving the appointment of Laz Martinez as the Director of Information and Technology for the City of Spokane.

WHEREAS, Section 24 of the City Charter provides that the Mayor shall have the power to appoint department heads subject to the approval of the City Council; and

WHEREAS, Section 2.14 F of the City Council Rules of Procedures states that approval of appointment of department heads shall be by resolution during the City Council's legislative session; and

WHEREAS, after full consideration, Mayor Lisa Brown has appointed Laz Martinez as the Director of Information and Technology for the City of Spokane.

NOW, THEREFORE, BE IT RESOLVED by the City Council for the City of Spokane that it hereby approves the appointment of Laz Martinez as the Director of Information and Technology for the City of Spokane.

ADOPTED BY THE CITY COUNCIL ON _____, 2024.

City Clerk

Approved as to form:

Assistant City Attorney



Agenda Sheet for City Council:

Committee: Urban Experience **Date:** 08/12/2024

Committee Agenda type: Discussion

Date Rec'd

7/23/2024

Clerk's File #

RES 2024-0077

Cross Ref #

Project #

Council Meeting Date: 08/12/2024

Submitting Dept

CITY COUNCIL

Bid #

Contact Name/Phone

KEVIN 6184

Requisition #

Contact E-Mail

KFREIBOTT@SPOKANECITY.ORG

Agenda Item Type

Resolutions

Council Sponsor(s)

ZZAPPONE JBINGLE KKLITZKE

Agenda Item Name

THE NATIVE PROJECT FUNDING RESOLUTION

Agenda Wording

A resolution acknowledging the recommendation of the Neighborhood Project Advisory Committee for the West Quadrant Tax Increment Financing district and accepting the use of \$190,000 in TIF funding for public improvements to be installed as part of th

Summary (Background)

In August 2023 the NPAC heard a request from The NATIVE Project for the use of TIF funds in support of their proposed new Children and Youth Behavioral Health Project at 1907 W Maxwell Avenue. The NATIVE Project is seeking reimbursement of costs related to public improvements on the site necessary for the development, including streetscape, sidewalk, utility, and landscaping costs within the City Right-of-Way and related to a city-owned water line that traverses their site.

Lease? NO

Grant related? NO

Public Works? NO

Fiscal Impact

Approved in Current Year Budget? YES

Total Cost \$ 190000

Current Year Cost \$ 190000

Subsequent Year(s) Cost \$ 0

Narrative

Amount

Budget Account

Expense \$ 190000

3501-36230-42300-54201-99999

Select \$

#

Select \$

#

Select \$

#

\$

#

\$

#



Continuation of Wording, Summary, Approvals, and Distribution

Agenda Wording

Summary (Background)

Approvals

Dept Head

CWRIGHT

Division Director

CWRIGHT

Accounting Manager

ORLOB, KIMBERLY

Legal

PICCOLO, MIKE

For the Mayor

CWRIGHT

Additional Approvals

Distribution List

nzollinger@spokanecity.org

korlob@spokanecity.org

Committee Agenda Sheet

Urban Experience Committee

Committee Date	July 8, 2024
Submitting Department	Planning & Economic Development
Contact Name	Kevin Freibott
Contact Email & Phone	kfreibott@spokanecity.org x6184
Council Sponsor(s)	<u>Zack Zappone</u>
Select Agenda Item Type	<input type="checkbox"/> Consent <input checked="" type="checkbox"/> Discussion Time Requested: 15 mins
Agenda Item Name	The NATIVE Project – WQTIF Funding Resolution
Proposed Council Action	<input checked="" type="checkbox"/> Approval to proceed to Legislative Agenda <input type="checkbox"/> Information Only
Summary (Background) *use the Fiscal Impact box below for relevant financial information	<p>The City adopted the West Quadrant Tax Increment Financing (WQTIF) district in 2007 to foster greater economic development and growth in the area inside and in the vicinity of Kendall Yards. Expenditures of WQTIF funds in the Neighborhood Improvements Area (outside Kendall Yards) is prioritized and recommended by the City’s Neighborhood Project Advisory Committee (NPAC).</p> <p>In August 2023 the NPAC heard a request from The NATIVE Project for the use of TIF funds in support of their proposed new Children and Youth Behavioral Health Project at 1907 W Maxwell Avenue. The NATIVE Project is seeking reimbursement of costs related to public improvements on the site necessary for the development, including streetscape, sidewalk, utility, and landscaping costs within the City Right-of-Way and related to a city-owned water line that traverses their site.</p> <p>The NPAC discussed this proposal at several meetings and ultimately recommended the City Council expend up to \$102,000 in TIF funds to reimburse the NATIVE Project for these costs in a unanimous vote on November 1, 2023. Since that time the NATIVE Project has faced unexpected increased costs for those public improvements, due to circumstances and physical conditions outside their control. They revisited the NPAC on May 1, 2024, during which the NPAC voted unanimously to revise their recommendation “not to exceed \$190,000.” This amount includes a small buffer to avoid having to revisit this item if any additional new costs are discovered.</p> <p>It is important to note that all three neighborhoods benefitted by the WQTIF have submitted letters of support for the proposal.</p> <p>The item before the Urban Experience Committee today is a draft resolution acknowledging the NPACs recommendation in this matter and requesting staff to prepare the necessary contracts and documentation for reimbursement of up to \$190,000 in WQTIF funds to the NATIVE Project.</p>
Fiscal Impact Approved in current year budget? <input checked="" type="checkbox"/> Yes <input type="checkbox"/> No <input type="checkbox"/> N/A Total Cost: <u>\$190,000</u> Current year cost: \$190,000 (not to exceed) Subsequent year(s) cost: \$0	

Narrative: All improvements must be constructed and inspected prior to reimbursement for their installation. Upon reimbursement, those improvements become the property of the City. All labor must be according to prevailing wage. Planning & Economic Development staff as well as City Legal will review all documentation and contracts prior to bringing them before Council for approval and payment.

Funding Source One-time Recurring N/A

Specify funding source: Taxes

Is this funding source sustainable for future years, months, etc? The WQTIF is expected to generate significant funds continually through the life of the TIF.

Expense Occurrence One-time Recurring N/A

Other budget impacts: (revenue generating, match requirements, etc.) None.

Operations Impacts (If N/A, please give a brief description as to why)

What impacts would the proposal have on historically excluded communities?

While the NATIVE project serves everyone, their programs and facilities are based around the native communities in Spokane. The NATIVE Project is a federally qualified health center and urban Indian health clinic, providing comprehensive care to the greater Spokane Community.

How will data be collected, analyzed, and reported concerning the effect of the program/policy by racial, ethnic, gender identity, national origin, income level, disability, sexual orientation, or other existing disparities?

City inspectors will ensure that the improvements are installed according to the current City, state, and federal standards. As these are City-owned and maintained facilities they will be subject to the same monitoring and analysis as any city-owned property.

How will data be collected regarding the effectiveness of this program, policy or product to ensure it is the right solution?

N/A This is a one-time expense related to a single-construction project.

Describe how this proposal aligns with current City Policies, including the Comprehensive Plan, Sustainability Action Plan, Capital Improvement Program, Neighborhood Master Plans, Council Resolutions, and others?

The West Quadrant TIF is an essential component of the City's economic development strategy for the district, providing funding for public improvements that would otherwise have to be sourced from the general budget and other funds. During the process of considering requests for funding, the Neighborhood Project Advisory Committee undertakes outreach and coordination with the associated Neighborhood Councils to ensure that their input is considered in the decision-making process. Furthermore, Planning & Economic Development staff undertake required due diligence to ensure consistency with the law and City ordinances/resolutions.

RESOLUTION NO. 2024-0077

A resolution acknowledging the recommendation of the Neighborhood Project Advisory Committee for the West Quadrant Tax Increment Financing district and accepting the use of \$190,000 in TIF funding for public improvements to be installed as part of the NATIVE Project Children and Youth Behavioral Health Project.

WHEREAS, the City of Spokane formed a West Quadrant Tax Increment Financing (“WQTIF”) area, to help provide funding for public improvement projects in and around the Kendall Yards planned unit development (“PUD”) area, and designated project types within the area, along with estimated costs for those projects within the life of the WQTIF; and

WHEREAS, City of Spokane Resolution 2007-0101 formed the Neighborhood Project Advisory Committee (“NPAC”) to make recommendations for the use of funds received in the WQTIF area, composed of residents of the West Central, Riverside, and Emerson-Garfield neighborhoods; and

WHEREAS, the NPAC meets regularly to review fund balances, proposed projects, potential allocations and to prioritize projects; and

WHEREAS, the NPAC met on August 2, 2023 to hear a request from representatives of the NATIVE Project for TIF funds for the repayment of costs related to required public improvements for their upcoming Children and Youth Behavioral Health Project at 1907 W Maxell Avenue; and

WHEREAS, the NPAC continued to deliberate on the proposal at their October 4, 2023 meeting; and

WHEREAS, the NPAC has determined that the proposed improvements are within the WQTIF boundary, represent the types of projects for which allocation of the WQTIF funds is authorized by ordinance C34032, as amended by ordinance C35879, and that the requested allocation is an authorized use of the WQTIF funds; and

WHEREAS, at their November 1, 2023 meeting the NPAC voted unanimously to recommend the City Council approve the use of funds for the proposed project in the amount of \$102,000; and

WHEREAS, at their May 1, 2024 meeting the NPAC heard a request from the NATIVE project for an increase in the allowed funds due to unforeseen increased public improvements costs, following which the NPAC voted unanimously to revise their recommendation not to exceed \$190,000.

NOW THEREFORE, BE IT RESOLVED that the Spokane City Council adopts the recommendations of the NPAC allocating WQTIF funds for repayment of costs for public improvements related to construction of the NATIVE Project Children and Youth Services Project, and requests staff prepare contracts and documents necessary for the repayment of those costs from the West Quadrant TIF Neighborhood Improvements account.

Adopted by the Spokane City Council this ____ day of _____, 2024.

City Clerk

Approved as to form:

Assistant City Attorney



THE NATIVE PROJECT

1803 West Maxwell Ave

Spokane, Washington 99201-2831

Clinic: (509) 483-7535 + Counseling: (509) 325-5502 + Administration: (509) 325-5502

TO: Kevin Frebott, City of Spokane Planner and TIF Committee Members
 FROM: NATIVE PROJECT Staff
 RE: TIF Committee Grant
 DATE: 8/2/23

Thank you for the opportunity to submit NATIVE Project’s proposed facility needs, proposed facility design, cost and plan for expansion. NATIVE Project proposes to build a new Children and Youth Behavioral Health facility across the street from our current medical clinic at 1803 West Maxwell in Spokane, WA. This facility master plan has been in the works for the past few years but the work on the project was interrupted by COVID so we are excited at the possibility of completing this much needed project.

1. The 2010 U.S. Census said there were approximately 14,000+ Native people living in Spokane County. The 2020 Census states there are 24,000+ Natives in Spokane County (probably an undercount also due to COVID restrictions).

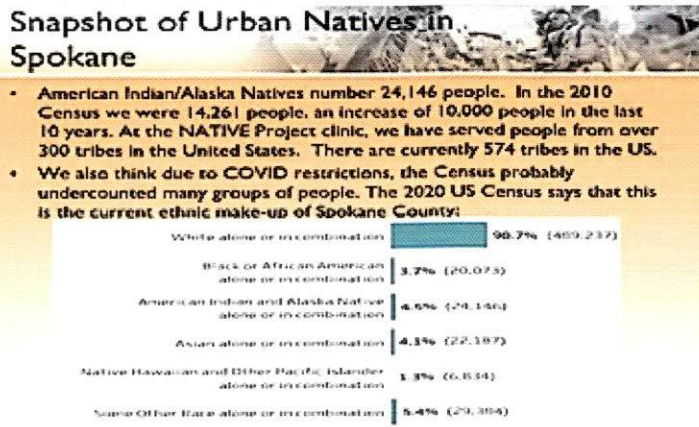

NATIVE Project is the only licensed mental health and substance use disorder outpatient facility for children and teens in Spokane County. In addition to integrated behavioral health and medical programs, we also deliver prevention and culture programs to children and teens in the form of the Indian Community Wellness Program; the Indian Youth Leadership Program; and the Indian Youth Summer Program. Our requests for services for children and youth have greatly increased post-COVID. In a county where only 2-4.5% of the population is Native, American Indian/Alaska Native kids make up 25% of all the children involved in the child welfare system in Spokane. These are some of the patients we want to create space and services for. With the expansion of our services, we will be able increase capacity by at least 30% of encounters.

2. In 2019, we purchased the property across the street for \$201,000 (attachment A and B) and contracted with Womer and Associates (A Native owned architectural business) for \$26,000 to develop a preliminary design, do a community charrette (public workgroup and survey), and develop a preliminary cost breakdown (attachment D).



THE NATIVE PROJECT

1803 West Maxwell Ave

Spokane, Washington 99201-2831

Clinic: (509) 483-7535 + Counseling: (509) 325-5502 + Administration: (509) 325-5502

3. We have developed a beautiful four story building (including a cultural healing circle space) to serve our children, youth and families to offer an integrated care campus (medical, behavioral health and prevention co-located in close proximity to each other.
4. We have been working to secure capital funding and were able to save \$1m in reserves to anchor the project. We received \$500,000 from the Group Health Foundation; \$100,000 from the City of Spokane Cultural Fund; \$535,000 from HRSA Construction Improvements; and applied to the WA State Legislature for funding via the WA State Dept. of Commerce and received a \$1.4m grant from them. In our application to the State of WA Dept. of Commerce, we documented the need for expanded services, a new facility and the documentation for **the total cost of the project of \$11,665,400**. We need approximately \$2,730,895 to bring this project to completion.
5. We are asking the City of Spokane West Central Neighborhood TIF committee for **\$310,191** to assist with this necessary project.

NATIVE Project has done a capital campaign in the past and purchased property and built our existing clinic facility. We have shown we are responsive to the needs of our growing community, especially to our children and teens where we can provide the most effective interventions in treating the trauma that incubated during COVID and from our collective historical traumas. We have done the preliminary work to set this new building in motion and are ready to begin construction with the additional resources we hope the City of Spokane TIF Committee will consider us for. Please call if we can answer any more questions. Respectfully,

Toni Lodge

Chief Executive Officer

The NATIVE Project

1803 W Maxwell Ave

Spokane, WA 99201

(509) 325-5502

www.nativeproject.org



≡ SACRED HOSPITALITY FOR ALL ≡

www.nativeproject.org



OUR SERVICES

≡ SACRED HOSPITALITY FOR ALL ≡

We are a primary health care facility that provides comprehensive health care to the greater Spokane community. We serve ALL people. Medicaid, Medicare, sliding fee scale, and most private insurances are accepted. You will not be charged your insurance co-pay if you provide proof of tribal enrollment/ descendency. We take pride in providing culturally competent services:



Medical:

- Full service medical care, including well child exams, women’s and men’s health, elder care, treatment of illness, labs, minor surgical procedures, immunizations
- Mental health referrals and prescription management for Adults
- Community Wellness Program
- Diet and nutrition counseling
- Full service pharmacy
- Integrated medical and behavioral health services for adults
- Referrals to specialty care

Patient Care Coordination

- Adult Behavioral Health and Women’s Health Care Coordination
- Chronic Disease Management Care Coordination
- Medical Case Management and Homeless Services Care Coordination
- Medical Referrals Care Coordination
- Patient Benefits Care Coordination
- Insurance Assistance



Dental:

- Preventative Care
- Emergency Appointments
- Extractions
- Restorative



Diabetes Program

- Diabetes Management Program, including nutrition and weight management consults
- Diabetes classes and hypertension classes



Behavioral Health:

- Youth substance use disorder treatment services and assessments
- Drug and alcohol treatment aftercare and 12 Step Groups for teens
- BHO Co-Occurring Disorder and Mental Health Counseling for children and youth, including family counseling
- BHO Indian Child Welfare Therapy Program for children and teens



1803 W MAXWELL AVE, SPOKANE, WA 99201
MEDICAL & DENTAL: 509-483-7535 | BEHAVIORAL HEALTH: 509-325-5502

"This health center receives HHS funding and has federal PHS deemed status with respect to certain health or health-related claims, including medical malpractice claims, for itself and its covered individuals." For more information, see <https://www.bphc.hrsa.gov/ftca/>

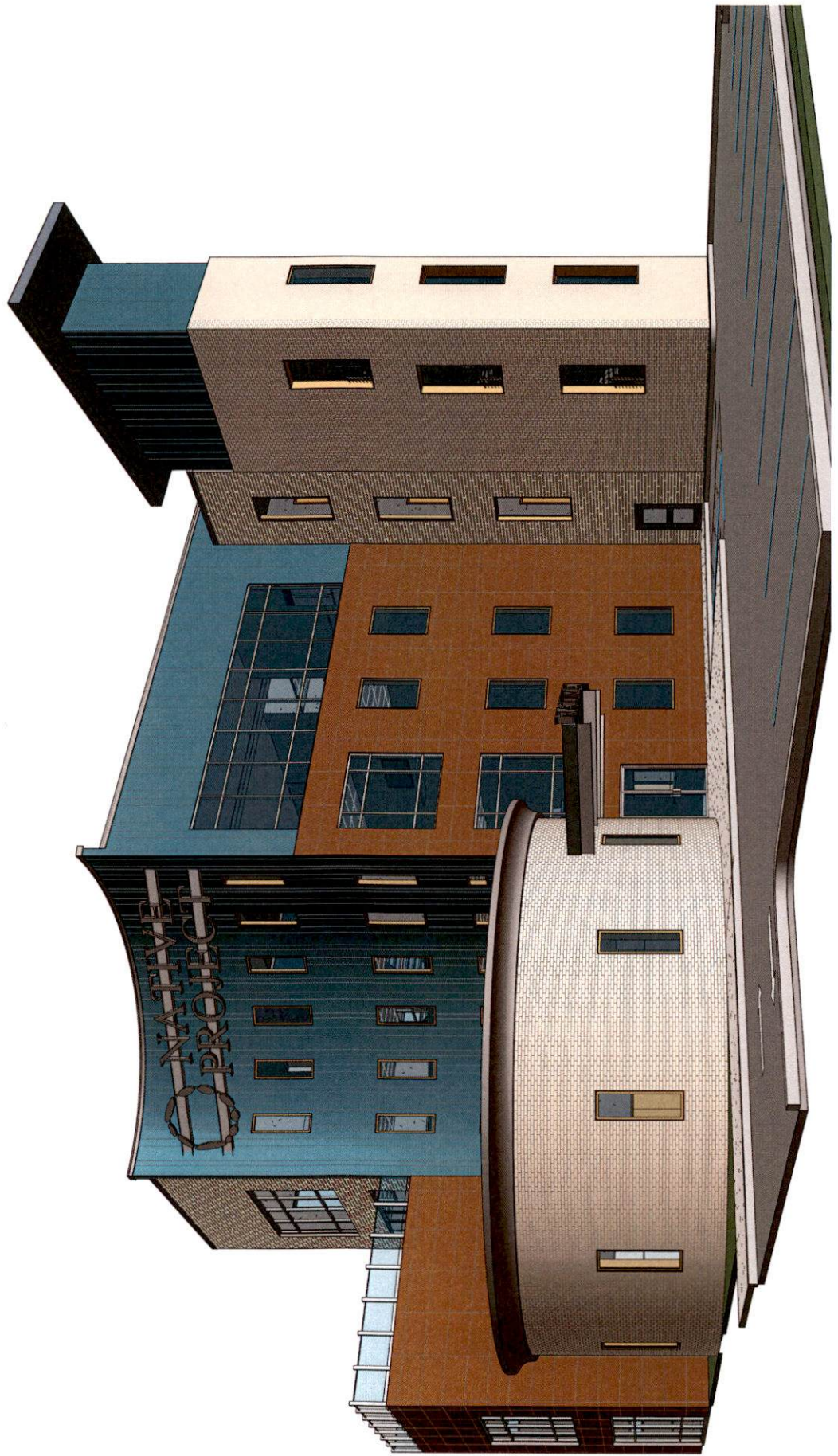

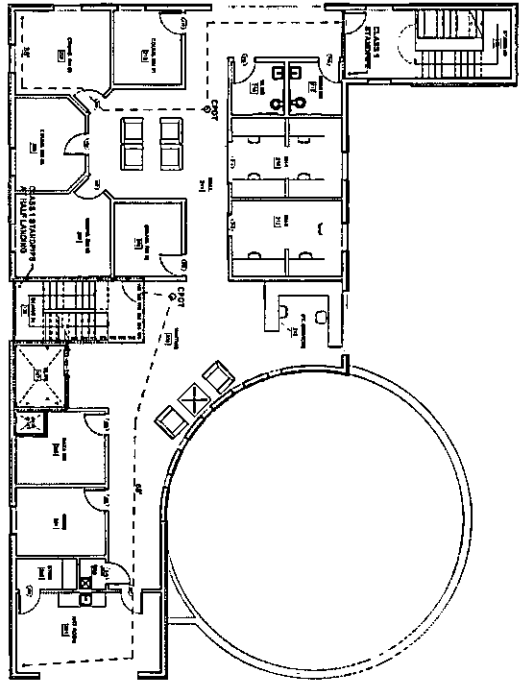

SECOND FLOOR CODE PLAN
1/8" = 1'-0"

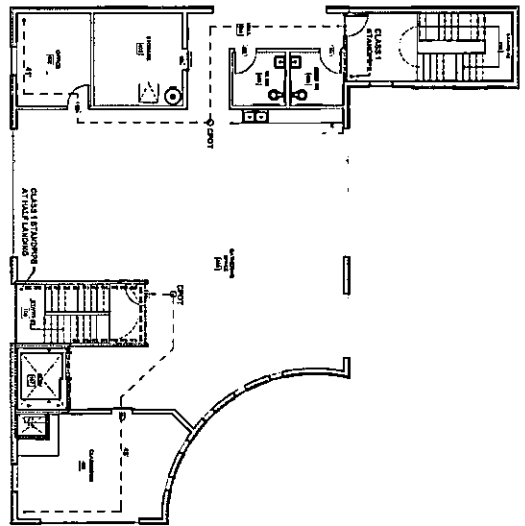

FIRST FLOOR CODE PLAN
1/8" = 1'-0"

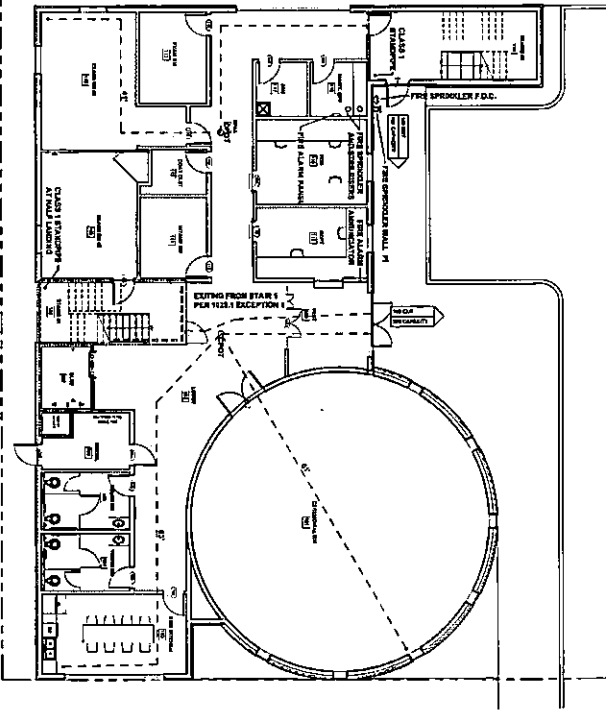

MAIN FLOOR CODE PLAN
1/8" = 1'-0"

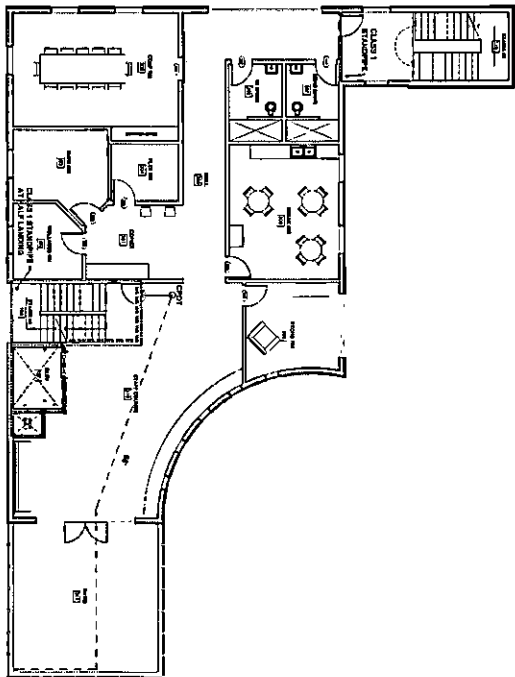

THIRD FLOOR CODE PLAN
1/8" = 1'-0"

- CODE LEGEND:**
- 3/8" LINE PARTITION
 - 1/4" LINE PARTITION
 - FIRE PARTITION
 - FIRE BRICK/CONCRETE
 - 420 DIRT
 - CHIT
 - CONCRETE FINISH OF WALL
 - PAINT OF WALL
 - TYPICAL APPLICATION
 - NON-TYPICAL APPLICATION

DATE	DESCRIPTION

CODE SHEET

WOMER & ASSOCIATES
 ARCHITECTURE • ENGINEERING • PLANNING

Suite 800 - 221 N. West St., Spokane, Washington 99201
 TEL: (509) 534-4884 FAX: (509) 534-4943 www.womer.com



NO.	REV.	DATE	DESCRIPTION

G1.02

Civil Improvements within City of Spokane Right of Way

3-28-24

NO.	ITEMS OF WORK AND MATERIALS	UNIT	TOTAL QUANTITY	UNIT PRICE	TOTAL AMOUNT
SITE PREPARATION					
1	Remove Concrete Walks	SY	186.0	50.00	\$ 9,300
2	Remove Concrete Curb	LF	154.0	30.00	\$ 4,620
3	Sawcut & Remove Asphalt	SY	41.0	35.00	\$ 1,435
4	Remove Existing Fence	LF	20.0	20.00	\$ 400
				SUBTOTAL	\$15,755
SITE IMPROVEMENTS					
5	Curbs-Curb and Gutter	LF	154.0	75.00	\$ 11,550
6	Concrete Sidewalks	SY	186.0	30.00	\$ 5,580
7	Asphalt Paving	SF	369.0	10.60	\$ 3,911
8	Concrete Driveway Entries	SY	25.0	225.00	\$ 5,625
9	Avista powerline relocation	LS	98.0	214.00	\$ 20,972
10	Trenching & Conduit for Avista utilities	LF	99.0	333.00	\$ 32,967
11	Trenching & Conduit for Franchise utilities	LF	98.0	187.00	\$ 18,326
12	Trenching & Conduit for Owner Inter-Building Communicatio	LF	206.0	35.00	\$ 7,210
				SUBTOTAL	\$ 106,141
Landscape and Irrigation					
13	Landscape and Irrigation	LS	1.0	5000	\$ 5,000
				SUBTOTAL	\$ 5,000
Site Civil/Mechanical Utilities					
14	4" Water Service Lines	LF	48.0	60	\$ 2,880
15	2" Domestic Water Service Line	LF	5.0	40	\$ 200
16	Connect to Existing Water Main	EA	1.0	7500	\$ 7,500
17	2" Water Meter	EA	1.0	7500	\$ 7,500
18	1-1/2" Irrigation Meter	EA	1.0	3500	\$ 3,500
19	4" Backflow Preventer	EA	1.0	10000	\$ 10,000
20	Connect to Existing Sewer Main	EA	1.0	5000	\$ 5,000
21	Vibration Monitoring & Video Inspection of Existing Sewer Main	LS	1.0	0	\$ -
				SUBTOTAL	\$ 36,580

Combined Totals	\$163,476.40
------------------------	---------------------

Total Estimate	\$163,476.40
-----------------------	---------------------

From: WCNC Chair <wcnc.chair@gmail.com>

Sent: Monday, September 4, 2023 9:06 PM

To: Freibott, Kevin <kfreibott@spokanecity.org>; Maureen Rosette <mrosette@nativeproject.org>

Subject: WCNC Approval

You don't often get email from wcnc.chair@gmail.com. [Learn why this is important](#)

WCNC

Kevin Freibott & West Quadrant Tif board

Dear Sir's

The West Central Neighborhood Council supports the request from the Native Project for TIF funds for their expansion project adjacent to their location. The WCNC is supportive of this project which will bring much needed mental health care to our neighborhood and hope the West Quadrant TIF board will approve the Native Project request for Funds.

Sincerely

Kelly Cruz

Chair WCNC



EMERSON-GARFIELD NEIGHBORHOOD COUNCIL

emersongarfield.org

October 12, 2023

RE: Letter of Support for the NATIVE Project, TIFF Committee Grant

Dear Kevin Frebott and TIF Committee Members,

I am writing to convey the Emerson-Garfield Neighborhood Council's wholehearted support for the NATIVE Project in its funding request. It was the unanimous will of the Emerson-Garfield Neighborhood Council (EGNC) to voice this expression of support.

The community members of the Emerson Garfield neighborhood, along with so many others in Spokane, are beneficiaries of the services and care provided by the NATIVE Project. With the expansion and plans for the new Children and Youth Behavioral Health Facility, that reach and positive impact will be an even larger asset to our entire city. Their passion for the safety and well-being of youth, families, and individuals is a beacon in a time where equitable and comprehensive care can be difficult to access.

It is our hope that the West Quadrant TIF board approve the NATIVE Project's request for funds. Thank you for your consideration.

Respectfully,

A handwritten signature in black ink, appearing to read 'Dani DeJaegher'. The signature is written in a cursive style with a long, sweeping underline that extends to the right.

Dani DeJaegher, Vice-chair
Emerson-Garfield Neighborhood Council

Riverside Neighborhood Council

October 19, 2023

RE: Letter of Support for the NATIVE Project,

TIFF Committee Grant Dear Kevin Freibott and TIF Committee Members,

At our meeting on October 17, 2023 the Riverside Neighborhood Council unanimously voted our enthusiastic support for the NATIVE Project in its funding request for a TIF grant. Many of the community members of the Riverside neighborhood are young people who will benefit greatly from the expansion and plans for the new Children and Youth Behavioral Health Facility.

We know mental health is a critical need in our community and the Native Project expansion will have a positive impact and be an even larger asset to our entire city. The Native Project's passion for the safety and well-being of youth, families, and individuals is a ray of hope in a time where equitable and comprehensive care can be difficult to access. It is our hope that the West Quadrant TIF board approve the NATIVE Project's request for funds.

Thank you for your consideration.

Sincerely,

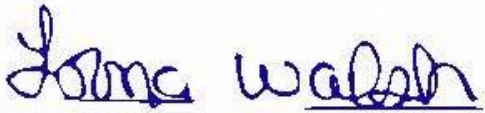
A handwritten signature in blue ink that reads "Lorna Walsh". The signature is written in a cursive style and is positioned above a thin horizontal line.

Lorna Walsh
Riverside Neighborhood Council
Community Assembly Representative

**Agenda Sheet for City Council:****Committee:** Urban Experience **Date:** 06/10/2024**Committee Agenda type:** Discussion**Date Rec'd**

6/11/2024

Clerk's File #

ORD C36120

Cross Ref #**Project #****Council Meeting Date:** 06/24/2024**Submitting Dept**

DEVELOPMENT SERVICES CENTER

Bid #**Contact Name/Phone**

ELDON BROWN 509-625-6305

Requisition #**Contact E-Mail**

EBROWN@SPOKANECITY.ORG

Agenda Item Type

Final Reading Ordinance

Council Sponsor(s)

ZZAPPONE KKLITZKE

Agenda Item Name

FINALIZING VACATION ORDINANCE C-36120

Agenda Wording

Proposing to send to City Council for final reading of the ordinance.

Summary (Background)

On October 25, 2021, right-of-way vacation ordinance C-36120 for the VOA Hope House passed (subject to conditions) and the ordinance was read for the first time. Since that time, the applicant has come to an agreement with the adjoining neighbors regarding how striping, signing, and parking will be accomplished and enforced along the west curblineline of Adams St.

Lease? NO

Grant related? NO

Public Works? NO

Fiscal Impact

Approved in Current Year Budget? N/A

Total Cost

\$

Current Year Cost

\$

Subsequent Year(s) Cost

\$

Narrative**Amount****Budget Account**

Select

\$

#

Select

\$

#

Select

\$

#

Select

\$

#

\$

#

\$

#



Continuation of Wording, Summary, Approvals, and Distribution

Agenda Wording

Summary (Background)

Approvals

Dept Head

PALMQUIST, TAMI

Division Director

MACDONALD, STEVEN

Accounting Manager

ORLOB, KIMBERLY

Legal

SCHOEDEL, ELIZABETH

For the Mayor

PICCOLO, MIKE

Additional Approvals

Distribution List

smacdonald@spokanecity.org

tpalmquist@spokanecity.org

ebrown@spokanecity.org

edjohnson@spokanecity.org

kkuchlenz@spokanecity.org

erivera@spokanecity.org

Committee Agenda Sheet [Urban Experience Committee]

Submitting Department	Development Services
Contact Name & Phone	Eldon Brown – 509-625-6305
Contact Email	ebrown@spokanecity.org
Council Sponsor(s)	TBD
Select Agenda Item Type	<input type="checkbox"/> Consent <input checked="" type="checkbox"/> Discussion Time Requested: <u>10 Mins</u>
Agenda Item Name	Finalizing Vacation Ordinance C-36120
Summary (Background)	<p>On October 25, 2021, right-of-way vacation ordinance C-36120 for the VOA Hope House passed (subject to conditions) and the ordinance was read for the first time.</p> <p>Since that time, the applicant has come to an agreement with the adjoining neighbors regarding how striping, signing, and parking will be accomplished and enforced along the west curblineline of Adams St.</p>
Proposed Council Action & Date:	Proposing to send to City Council for final reading of the ordinance.
Fiscal Impact:	
Total Cost:	
Approved in current year budget? <input type="checkbox"/> Yes <input type="checkbox"/> No <input type="checkbox"/> N/A	
Funding Source <input type="checkbox"/> One-time <input type="checkbox"/> Recurring	
Specify funding source:	
Expense Occurrence <input type="checkbox"/> One-time <input type="checkbox"/> Recurring	
Other budget impacts: (revenue generating, match requirements, etc.)	
Operations Impacts	
What impacts would the proposal have on historically excluded communities? NA	
How will data be collected, analyzed, and reported concerning the effect of the program/policy by racial, ethnic, gender identity, national origin, income level, disability, sexual orientation, or other existing disparities? NA	
How will data be collected regarding the effectiveness of this program, policy or product to ensure it is the right solution? NA	
Describe how this proposal aligns with current City Policies, including the Comprehensive Plan, Sustainability Action Plan, Capital Improvement Program, Neighborhood Master Plans, Council Resolutions, and others? NA	

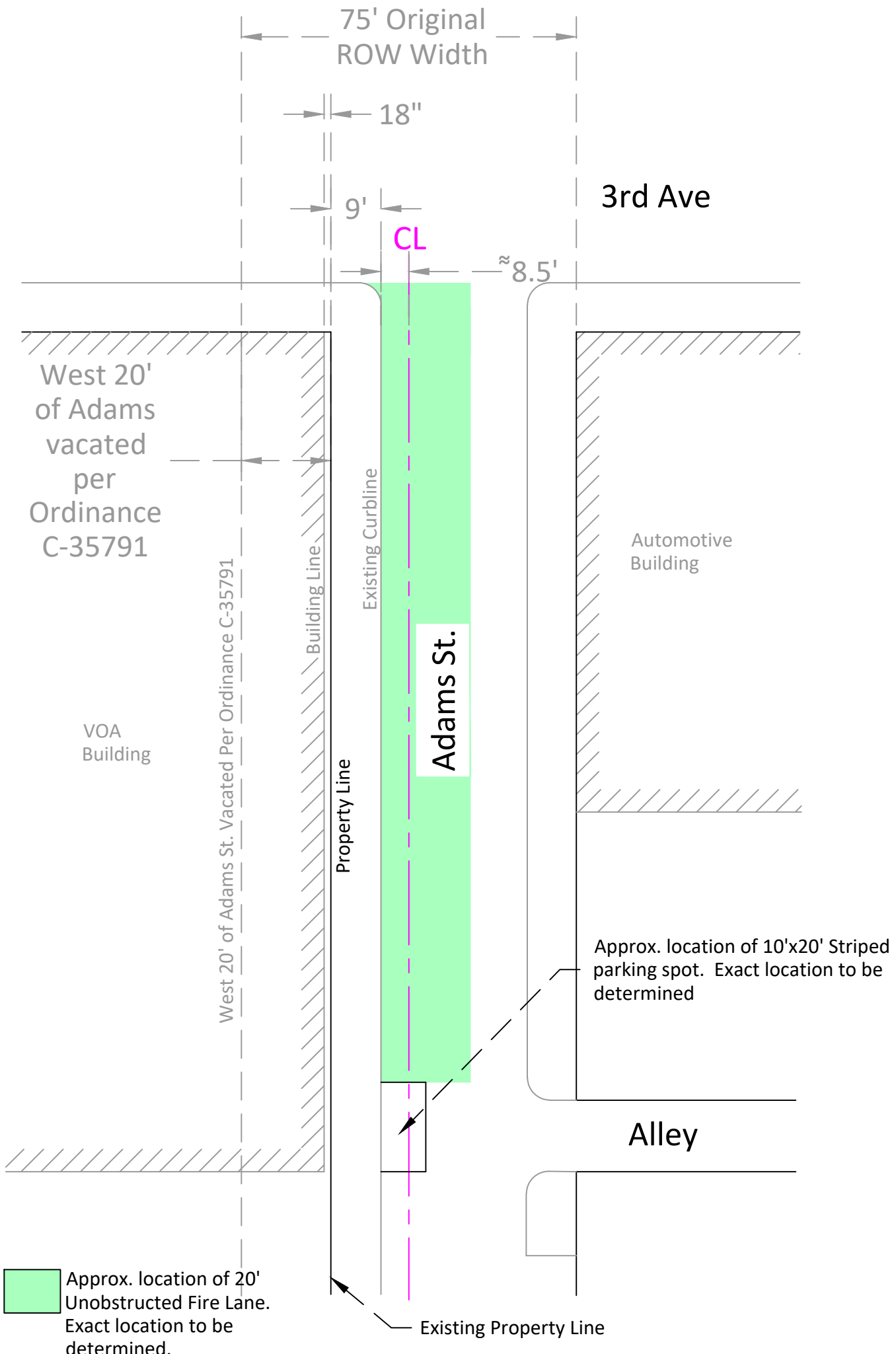

Approx. location of 20' Unobstructed Fire Lane. Exact location to be determined.

Existing Property Line

TRANSMITTAL OF FIRST READING ORDINANCE

DATE: November 17, 2021

TO: Erik Johnson
Engineering Services

Clerk's File No.
ORD C36120

FROM: Terri Pfister, City Clerk

RE: Vacation of Adams Street from the south line of Third Avenue

Attached is a copy of Ordinance C36120 for the vacation of:

the east 55 feet of Adams Street from the south line of Third Avenue to the north line of I-90, together with the alley between Third Avenue and I-90, from the east line of Adams Street to the west line of Jefferson Street.

This ordinance was read for the first time on October 25, 2021, and will be read for the final time when the necessary conditions have been met and this transmittal, signed and dated by the Engineering Services Director, is returned to the City Clerk's Office.



City Clerk

11/17/2021

Date

Precedent conditions have been met and Ordinance C36120 is hereby returned for Final Reading.



Principal Engineer – Developer Services

Dated: 6/13/24



OFFICE OF THE CITY CLERK
808 W. SPOKANE FALLS BLVD.
SPOKANE, WASHINGTON 99201-3342
509.625.6350

October 25, 2021

City Clerk File No.:
ORD C36120

COUNCIL ACTION MEMORANDUM

RE: HEARING ON THE VACATION OF ADAMS STREET AND THE NEARBY ALLEY BETWEEN THIRD, I-90, ADAMS, AND JEFFERSON, AS REQUESTED BY THE VOLUNTEERS OF AMERICA HOPE HOUSE

During its 6:00 p.m. Legislative Session held virtually Monday, October 25, 2021, the Spokane City Council held a hearing on the above-described vacation. Subsequent to a presentation by Eldon Brown of Developer Services, public testimony, and Council commentary, the following action was taken:

Upon Unanimous Roll Call Vote, the City Council **approved, subject to conditions** (in the Street Vacation Report dated August 26, 2021), the vacation of Adams Street and the nearby alley between Third, I-90, Adams, and Jefferson.

Ayes: Beggs, Burke, Cathcart, Kinnear, Mumm, Stratton, and Wilkerson
Nays: None
Abstain: None
Absent: None

In conjunction with the hearing, Ordinance C36120—vacating the east 55 feet of Adams Street from the south line of 3rd Avenue to the north line of I-90, together with the alley between 3rd Avenue and I-90, from the east line of Adams Street to the west line of Jefferson Street—was read for the first time, with further action deferred.



Terri L. Pfister, MMC
Spokane City Clerk



Agenda Sheet for City Council Meeting of:
10/25/2021

Date Rec'd	10/13/2021
Clerk's File #	ORD C36120
Renews #	

Submitting Dept	DSC, CODE ENFORCEMENT &	Cross Ref #	
Contact Name/Phone	ELDON BROWN 6305	Project #	
Contact E-Mail	EBROWN@SPOKANECITY.ORG	Bid #	
Agenda Item Type	First Reading Ordinance	Requisition #	
Agenda Item Name	4700 - STREET VACATION OF ADAMS ST. AND THE ALLEY BETWEEN 3RD, I-90,		

Agenda Wording
Vacation of Street Vacation of Adams St. and the nearby alley between 3rd, I-90, Adams, and Jefferson, as requested by the VOA Hope House

Summary (Background)
At its legislative session held on September 20, 2021, the City Council set a hearing on the above vacation for October 25, 2021. Staff has solicited responses from all concerned parties.

Lease? NO	Grant related? NO	Public Works? NO
Fiscal Impact		Budget Account
Neutral \$		#
Select \$		#
Select \$		#
Select \$		#

Approvals		Council Notifications	
Dept Head	BECKER, KRIS	Study Session\Other	PIES - 08/23/2021
Division Director	BECKER, KRIS	Council Sponsor	CM Lori Kinnear
Finance	ORLOB, KIMBERLY	Distribution List	
Legal	RICHMAN, JAMES	edjohnson@spokanecity.org	
For the Mayor	ORMSBY, MICHAEL	ebrown@spokanecity.org	
Additional Approvals		kbecker@spokanecity.org	
Purchasing		rbenzie@spokanecity.org	

FIRST READING OF THE ABOVE
ORDINANCE HELD ON
10/25/2021
AND FURTHER ACTION WAS DEFERRED

CITY CLERK

City of Spokane
Development Services Center
808 West Spokane Falls Blvd.
Spokane, WA 99201-3343
(509) 625-6300

ORDINANCE NO. C36120

An ordinance vacating the east 55 feet of Adams Street from the south line of 3rd Avenue to the north line of I-90, Together with the alley between 3rd Avenue and I-90, from the east line of Adams Street to the west line of Jefferson Street.

WHEREAS, pursuant to Chapter 35.79 RCW, the City may initiate by resolution the vacation of any street or portion thereof when it is in the public interest; and

WHEREAS, the City Council desires to set a time and date through this resolution to hold a public hearing on the petition to vacate the above property in the City of Spokane;

The City of Spokane does ordain:

Section 1. That the east 55 feet of Adams Street, from the south line of 3rd Avenue to the north line of I-90, Together with the alley between 3rd Avenue and I-90, from the east line of Adams Street to the west line of Jefferson Street is hereby vacated. Parcel number not assigned.

Section 2. An easement is reserved and retained over and through the east 55 feet of Adams Street between the south line of 3rd Avenue and the north line of I-90 for the utility services of Verizon/MCI Metro, Zayo Communications, WSDOT, and the City of Spokane to protect existing and future utilities.

Section 3. An easement is reserved and retained over and through the alley between 3rd Avenue and I-90, from the west line of Jefferson Street to the east line of Adams Street and the alley's extension across Adams Street to the west line of Adams Street, for the utility services of Avista, Comcast, Lumen/CenturyLink, Verizon/MCI Metro, Zayo Communications, WSDOT, and the City of Spokane to protect existing and future utilities.

Passed the City Council _____

Council President

Attest: _____
City Clerk

Approved as to Form:

Assistant City Attorney

Mayor

Date: _____

Effective Date: _____

Proposed Vacation



Right-of-way Description:
Adams St. between 3rd and I-90, along with the alley
between 3rd and I-90, from Adams to Jefferson

Legend

 Proposed Vacation





**CITY OF SPOKANE
DEVELOPMENT SERVICES**

808 West Spokane Falls Blvd, Spokane WA 99201-3343
(509) 625-6300 FAX (509) 625-6822

STREET VACATION REPORT
August 26, 2021

LOCATION: Adams between the south line of 3rd and I90 EXCEPT the west 20 feet TOGETHER with the alley between 3rd and I-90, from Adams to Jefferson.

PROPONENT: Silverstar Automotive & Hope House Development.

PURPOSE: To control access and aid in security.

HEARING: October 18, 2021

REPORTS:

AVISTA UTILITIES

Adams St. – No Comments

Alleyway - Avista has gas, transmission, and distribution lines in the requested vacated area and would like an easement reserved over the entire area.

COMCAST

Adams St. - Comcast has reviewed the vacation request. Enclosed is a Comcast system map showing Coax and Fiber crossing Adams St in the Alley South of 3rd. Due to this we can't approve this vacation without having access to our plant.



Alleyway - We have no objections to the vacation as long as we can maintain an easement to allow us to access our existing aerial cable.

CENTURYLINK

Adams St. - CenturyLink is changing from aerial cable facilities to buried cable facilities in the W 3rd Ave-I-90 Alley from the east side of S Adams St extending west due to Avista rearranging a pole line. CenturyLink wants to maintain easements. Please see the attached drawing

<p>Job Location: 1301 W 3RD AVE</p>		<p>Narrative/Special Remarks</p> <p>THIS PROJECT IS FOR THE RELOCATION OF AERIAL FACILITIES IN THE ALLEY WAY BEHIND 1301 W 3RD AVE. WE ARE REMOVING A 300R COPPER CABLE AND PLACING A NEW UNDERGROUND PATH DUE TO AVA REARRANGING A POLE LINE.</p>
<p>DEVELOPER CONTACT</p> <p>Hold Order Information</p> <p>Service Order # _____ Customer Terminal# _____</p> <p>Customer Name: _____ Cable Assignment: _____</p> <p>Customer Address: _____ Cross Connect: _____</p>		<p>Misc. Information</p> <p>Form # Information</p> <p>App# of the Approved MO _____</p> <p>300R Term# Approved MO _____</p> <p>300R Term# Required MO _____</p> <p>400R Term# Approved MO _____</p> <p>400R Term# Required MO _____</p>
<p>PERMITS</p> <p>City of Portland: _____</p> <p>County of Multnomah: _____</p> <p>City of Vancouver: _____</p> <p>City of West Vancouver: _____</p>		<p>RELEVANT</p> <p>DATE: 5/29/2020</p> <p>CenturyLink</p>
<p>PN PROJECT</p> <p>N.681690</p>	<p>WMT PROJECT</p> <p>F.2724120</p>	<p>PROJECT TEAM</p> <p>PROJECT MANAGER: _____</p> <p>DESIGNER: _____</p> <p>CHECKER: _____</p> <p>DATE: _____</p>

Alleyway - CenturyLink has cable facilities in the right-of-way and would like to retain utility easements rights. These rights should provide for maintenance, construction, and reconstruction as needed.

ASSET MANAGEMENT - CAPITAL PROGRAMS

Adams St. – No Comments
Alleyway - A 12-inch sewer is located here. An easement will be required providing access. Not sure if the storm pipe is also at this location, but if it is, it will need to be part of the easement.

FIRE DEPARTMENT

Adams St. – No Comments
Alleyway - We have determined that this vacation does not appear to negatively affect or change our access.

NEIGHBORHOOD SERVICES

Adams St. – No Comments
Alleyway – No Comments

INLAND POWER

Adams St. – Inland Power & Light Co has no utility facilities within the proposed area.
Alleyway - Inland Power has no facilities within this area.

VERIZON

Adams St. – Verizon/MCIMetro currently has aerial fiber in this location and we do not wish to vacate any easement we currently have
Alleyway – We have a very large fiber that Avista has already approved to place on their new poles in that area. I'm assuming the pole lead is staying?

PARKS DEPARTMENT

Adams St. – No Comments
Alleyway – No Comments

ZAYO COMMUNICATIONS

Adams St. – Zayo has facilities on the poles with the Avista power in the proposed ROW vacation area. We would need to retain some access and utility easement along the current path.
Alleyway - Zayo has no objection and or comment on the vacation request of alley-Adams-Jefferson.

PLANNING & DEVELOPMENT – PLANNING

Adams St. – Planning wise, Council will just need to determine if this vacation facilitates a public benefit. Although this street dead ends and provides very little public benefit as it is now.

Section 17C.124.035 Characteristics of Downtown Complete Street Designations

The downtown zones are complemented by the complete streets designations map (described in detail in the downtown plan) that further guides public and private development within the downtown. The different complete streets designations set different street standards and desired amenities based upon the intended use and desired qualities of the street. The complete streets designations are depicted on Map 5.1 "Streetscape Improvements" in the downtown plan and zoning layer. Right-of-ways found on the complete streets map shall not be vacated as the space is needed to incorporate the elements described in the complete street designation; provided, upon a finding that a vacation is needed in order to accommodate a public use, the City Council may approve a request to vacate such right-of-ways or portions thereof. Curb to property line and the sidewalk width shall not be reduced in order to allow for future complete street elements. The complete streets designation types are summarized below:

When we met with WSDOT there was concerns with access and our utilities.

Alleyway – No concerns

POLICE DEPARTMENT

Adams St. – No Comments
Alleyway – No Comments

SOLID WASTE MANAGEMENT

Adams St. – No Comments
Alleyway – No Comments

STREET DEPARTMENT

Adams St. - We do not have comments on the current proposal, but would like to remind that we have a comment regarding the pending proposal to vacate the alley between Adams and Jefferson. See below.

The Signal and Lighting section of the Street Department has conduit run on the west side of Jefferson St, Third Ave. to Freeway Ave North, which crosses the alley. This conduit contains fiber optic cable. Because of this

conduit run, the Street Department does not support the vacation of this alley.

Alleyway – The Signal and Lighting section of the Street Department has conduit run on the west side of Jefferson St. Third Ave to Freeway Ave North which crosses the alley. This conduit contains Fiber Optic cable. Because of this conduit run, the Street Department does not support the Vacation of this alley.

WASTEWATER MANAGEMENT

Adams St. – No Comments

Alleyway – This is the third vacation request for this area. The first was made on Nov 6th, 2018 with our response on Nov 8th, 2018 which was for all of Adams from 3rd to 4th and the entire alley from Cedar to Jefferson. That was modified in the request we received on March 5th, 2019 (response on March 6th) that encompassed the alley from Cedar to Adams and the west half of Adams. Now this third request for the alley that was left out of the March revision.

We still strongly recommend denying this vacation request.

There is a city 12" sewer main, a city 12" storm main and a 27" WSDOT storm main in or near that alley.

With regards to the storm lines. The city line takes drainage from Lincoln and Monroe south as far as 17th and is an overflow for the pond at Monroe and 4th. The WSDOT main handles the majority of storm runoff from I-90 west of Division. As I stated before these would have to have a minimum 30' no build easement centered on the mains. WSDOT would have to be consulted as well to see if their requirements are met as far as easements for their line.

The sewer main is 12" diameter 12'-13' deep. We would typically require a minimum 30' easement around this as well, but the alley is only 16' wide and we already have buildings and footings uncomfortably close to that main (at 1217 W. 3rd). Complicating matters are the fact that there are a number of other utilities, including electricity and power poles and a gas main (possibly others) in that same alley. All of that means a big problem if any repair is ever required for that sanitary main.

If this is vacated we would also require any construction around that main to include replacement of the entire sewer main to minimize (but not eliminate) the chances of us having to dig in that area in the future.

When all of that is done we would still require a full width, full access easement for the alley from Adams to Jefferson which means no construction or structures in the alley and no fences or gates blocking access to the easement. In all cases where we are requesting an easement it should extend to the full 30' centered on each main at any location there is not already a structure built. This would extend into what is currently private property north of the alley.

Any and all new storm and sanitary construction, including but not limited to storm inlets and mains, sanitary mains and any service connections, should be done by the property owner and would all have to be subject to inspection and acceptance by Wastewater Management Dept.

WSDOT
Adams St.

– Thank you for the opportunity to review the above proposed vacation. In reviewing this vacation, WSDOT is concerned that if approved it would limit or prohibit our access to the I-90 right of way. WSDOT currently uses Adams Street as a means to reach our I-90 right of way where we have electrical components, water lines, and storm drains. Maintaining clear access to our right of way is important to WSDOT which is provided by Adams Street. Consequently, WSDOT is opposed to this vacation as it would cut off access to our right of way. Please let me know if you should have any questions on this matter

Alleyway

– Thank you for the opportunity to review the above requested vacation. In reviewing this proposed vacation the Washington State Department of Transportation (WSDOT) is opposed to the vacation for the following reasons:

WSDOT currently utilizes this alley to access our I-90 westbound off ramp. Our maintenance forces use this property to reach up to the ramp for electrical and other maintenance items.

1. WSDOT has electrical service cabinets located at ground level attached to the ramp which are accessed from the alley.
2. The alley is part of the local roadway network that could be utilized to relieve traffic on the adjacent east-west streets.

WATER DEPARTMENT

- Adams St. – No Comments
Alleyway – Water does not appear to have any facilities in the proposed vacation limits.

BICYCLE ADVISORY BOARD

- Adams St. – No Comments
Alleyway – No Comments

RECOMMENDATION: That a vacating ordinance be prepared subject to the following conditions:

1. An easement, as requested by Verizon/MCI Metro, Zayo Communications, WSDOT, and the City of Spokane shall be retained across the east 55 feet of Adams Street to protect existing and future utilities.
2. An easement, as requested by Avista Utilities, Comcast, CenturyLink/Lumen, Verizon/MCI Metro, WSDOT, and the City of Spokane shall be retained across the alley and the alley's extension across the east 55 feet of Adams St. to protect existing and future utilities.
3. In order for Silverstar Automotive (1227 W 3rd) to continue operating the existing business, an agreement will need to be established with the VOA that would prohibit parking on the west side of Adams St.
4. The applicant is requesting that City Council waive the requirement to pay the assessed value. If City Council does not waive the fee, the proponent shall pay to the City of Spokane the assessed valuation for the vacated land as defined by the latest information from the County Assessor's Office. This is calculated to be \$346,860.25 and is to be deposited to Budget Account #3200 49199 99999 39510.

Erin W. Dunn



Agenda Sheet for City Council:

Committee: Urban Experience **Date:** 07/08/2024

Committee Agenda type: Discussion

Date Rec'd

7/8/2024

Clerk's File #

ORD C36549

Cross Ref #

Project #

Council Meeting Date: 07/22/2024

Submitting Dept

CITY COUNCIL

Bid #

Contact Name/Phone

ANDRES 651-0855

Requisition #

Contact E-Mail

AGRAGEDA@SPOKANECITY.ORG

Agenda Item Type

First Reading Ordinance

Council Sponsor(s)

LNAVARRETE KKLITZKE

Agenda Item Name

0320 - HUMAN RIGHTS OF INDIVIDUALS EXPERIENCING HOMELESSNESS

Agenda Wording

An ordinance relating to the human rights and basic dignity of individuals experiencing homelessness; amending sections 9.02.050, 18.01.010, 18.01.020, 18.01.030 of the Spokane Municipal Code; and enacting a new Section 18.05.040 of the Spokane Munic

Summary (Background)

The Spokane Human Rights Commission adopted a resolution relating to the human rights and basic dignities of individuals experiencing homelessness in 2023. City Council, with help from Legal, created an ordinance with refined parameters based on the resolution. This ordinance adds "housing status" to the city's list of protected classes and strengthens protections against discriminatory hiring and employment practices, property rights and privacy rights of individuals experiencing homelessness.

Lease? NO Grant related? NO Public Works? NO

Fiscal Impact

Approved in Current Year Budget? N/A

Total Cost \$

Current Year Cost \$

Subsequent Year(s) Cost \$

Narrative

Amount

Budget Account

Neutral	\$	#
Select	\$	#
Select	\$	#
Select	\$	#
	\$	#
	\$	#

Committee Agenda Sheet

Urban Experience Committee

Committee Date	July 8, 2024
Submitting Department	City Council
Contact Name	Andres Grageda
Contact Email & Phone	agrageda@spokanecity.org (509)651-0855
Council Sponsor(s)	CM Navarrete, CM Klitzke
Select Agenda Item Type	<input type="checkbox"/> Consent <input checked="" type="checkbox"/> Discussion Time Requested: 5
Agenda Item Name	HUMAN RIGHTS OF INDIVIDUALS EXPERIENCING HOMELESSNESS
Proposed Council Action	<input checked="" type="checkbox"/> Approval to proceed to Legislative Agenda <input type="checkbox"/> Information Only
Summary (Background)	<p>The Spokane Human Rights Commission adopted a resolution relating to the human rights and basic dignities of individuals experiencing homelessness in October of 2023. Since then, the City Council, with help from Legal, has created an ordinance with refined parameters based on the resolution. This ordinance adds “housing status” to the city’s list of protected classes and strengthens protections against discriminatory hiring and employment practices, property rights and privacy rights of individuals experiencing homelessness.</p>
*use the Fiscal Impact box below for relevant financial information	
Fiscal Impact	
Approved in current year budget? <input type="checkbox"/> Yes <input type="checkbox"/> No <input checked="" type="checkbox"/> N/A Total Cost: Click or tap here to enter text. Current year cost: Subsequent year(s) cost:	
Narrative: Please provide financial due diligence review, as applicable, such as number and type of positions, grant match requirements, summary type details (personnel, maintenance and supplies, capital, revenue), impact on rates, fees, or future shared revenue	
Funding Source <input type="checkbox"/> One-time <input type="checkbox"/> Recurring <input checked="" type="checkbox"/> N/A Specify funding source: Select Funding Source* Is this funding source sustainable for future years, months, etc? Click or tap here to enter text.	
Expense Occurrence <input type="checkbox"/> One-time <input type="checkbox"/> Recurring <input checked="" type="checkbox"/> N/A Other budget impacts: (revenue generating, match requirements, etc.)	
Operations Impacts (If N/A, please give a brief description as to why) <ul style="list-style-type: none"> • What impacts would the proposal have on historically excluded communities? Individuals experiencing homelessness have experienced discrimination throughout history. This ordinance aims to add protections against these practices to ensure the human rights and basic dignities of these individuals.	

- How will data be collected, analyzed, and reported concerning the effect of the program/policy by racial, ethnic, gender identity, national origin, income level, disability, sexual orientation, or other existing disparities?

We depend on community members to report instances of discrimination through crime check, to our Office of Civil Rights, Equity and Inclusion or to the Spokane Human Rights Commission. This ordinance should make it clearer when and how an individual is being discriminated against based on their housing status and makes them more likely to report it.

- How will data be collected regarding the effectiveness of this program, policy, or product to ensure it is the right solution?

We will be depending on individuals to report instances of discrimination.

- Describe how this proposal aligns with current City Policies, including the Comprehensive Plan, Sustainability Action Plan, Capital Improvement Program, Neighborhood Master Plans, Council Resolutions, and others?

The resolution aligns with the Comprehensive Plan in many areas. Chapter 10 on social health mentions coordination with public and private agencies to evaluate existing needs and programs relative to health and human services. Chapter 6 on housing also discusses socioeconomic integration including people of all demographics, including economic status, which is impossible without elimination discrimination based on housing status.

Council Subcommittee Review

- Please provide a summary of council subcommittee review. If not reviewed by a council subcommittee, please explain why not.

We will present the Ordinance at the Spokane Human Rights Commission and at the Equity Subcommittee

ORDINANCE NO. C-36549

An ordinance relating to the human rights and basic dignity of individuals experiencing homelessness; amending sections 9.02.050, 18.01.010, 18.01.020, and 18.01.030 of the Spokane Municipal Code; and enacting a new Section 18.05.040 of the Spokane Municipal Code.

WHEREAS, the City of Spokane knows the issue of homelessness is one of the most pressing and complex situations encountered by our society; and

WHEREAS, in developing public policy to address homelessness, emphasis should be given to attending to the basic needs of the homeless and unhoused while preserving the dignity of these individuals in their circumstances; and

WHEREAS, unhoused and homeless individuals represent a diverse range of ages, education and backgrounds, and vary in their unmet basic needs, talents and dreams, and but all are possessed of inner and outer strengths that can be harnessed to improve their situation and benefit society as a whole; and

WHEREAS, homelessness threatens healthy community living among people, and as it grows it can generate and heighten attitudes of insensitivity, contempt, harshness, shunning, and

WHEREAS, the basic human and legal rights of the unhoused and homeless are frequently infringed because of such attitudes; and

WHEREAS, respect for the dignity of human beings and equality before the law are principles which are fundamental and nonexpendable to guarantee the common good and healthy community living as a people; and

WHEREAS, the City of Spokane should reassert its commitment to the constitutional principle that all people are equal before the law and that there must be no discrimination whatsoever on the basis of protected status as recognized in state and federal law, and in the Spokane Municipal Code; and

NOW THEREFORE, the City of Spokane does ordain:

Section 1. That section 9.02.050 of the Spokane Municipal Code is amended to read as follows:

Section 09.02.050 Prohibition

A. No employer shall:

1. advertise applicable employment openings in a way that excludes people with arrest or conviction records from applying, such as using advertisements which state “no felons,” “no criminal background,” or which otherwise convey similar messages; provided, employers may advertise the requirement for a criminal history inquiry and/or background check during or after the interview process as long as such advertisement does not state that an arrest or conviction record will automatically preclude the applicant from consideration for employment;
 2. include any question in an application for applicable employment, inquire orally or in writing, receive information through a criminal history background check, or otherwise obtain information about an applicant’s arrest or conviction record prior to an in-person, telephonic, or video interview or received a conditional offer of employment;
 3. use, distribute, or disseminate an applicant’s or employee’s arrest or conviction record except as required or otherwise allowed by law;
 4. disqualify an applicant from applicable employment prior to an in-person, telephonic, or video interview solely because of a prior arrest or conviction unless the conviction is related to significant duties of the job or disqualification is otherwise allowed by this chapter; or
 5. reject or disqualify an applicant for failure to disclose a criminal record prior to initially determining the applicant is otherwise qualified for the position; or
 6. reject or disqualify an applicant solely because the individual does not have a fixed or regular residence, or because the individual is homeless or unhoused, or because the individual lives on the street, in a shelter, or in a temporary residence, unless the individual’s housing status has a bona fide and legitimate relation to the primary duties of the job and such rejection or disqualification would also violate state or federal employment laws or regulations.
- B. Nothing in this chapter prohibits an employer from inquiring into or obtaining information about a job applicant’s criminal conviction or arrest record or background, and considering the information received regarding such record during an in-person, telephonic, or video interview, or after the conclusion of such a job interview, or after a conditional offer of employment, and using such information in a hiring decision.

Section 2. That section 18.01.010 of the Spokane Municipal Code is amended to read as follows:

Section 18.01.010 Findings

The City of Spokane finds that discrimination based on race, religion, creed, color, sex, national origin, marital status, familial status, housing status, domestic violence victim status, age, sexual orientation, gender identity, honorably discharged veteran or military status, refugee status, the presence of any sensory, mental or physical disability as defined by the Americans with Disabilities Act, 42 U.S.C. § 12101 et seq, and/or the Washington State Law Against Discrimination, Chapter 49.60 RCW, or the receipt of, or eligibility for the receipt of, funds from any housing choice or other subsidy program or alternative source of income poses a substantial threat to the health, safety and general welfare of the citizens of Spokane. The City deems it necessary and proper to enact a local ordinance to address these issues.

Section 3. That section 18.01.020 of the Spokane Municipal Code is amended to read as follows:

Section 18.01.020 Purpose and Intent

- A. The City values the dignity and worth of all human beings and is committed to promoting justice, equity and an inclusive environment for all by respecting cultural and individual diversity and fostering mutual understanding among all people regardless of race, religion, creed, color, sex, national origin, marital status, familial status, housing status, domestic violence victim status, age, sexual orientation, gender identity, honorably discharged veteran or military status, refugee status, the presence of any sensory, mental or physical disability as defined by the Americans with Disabilities Act and/or the Washington State Law Against Discrimination, or the receipt of, or eligibility for the receipt of, funds from any housing choice or other subsidy program or alternative source of income.
- B. It is the intent of the City that all people have an equal opportunity to participate fully in the life of the City and that discriminatory barriers to equal participation in employment, housing, and public accommodations be removed. The City has a compelling interest in eradicating and preventing such discrimination and in ensuring equal opportunity in employment, housing, and public accommodations. This Title 18 represents the least restrictive means of achieving the City's objectives.
- C. The provisions of this Title 18 are to be broadly and liberally construed to effectuate this Title's remedial purpose and the City's legislative intent.

- D. These sections are not intended to establish or require affirmative action or quotas of any kind, or to infringe upon the authority vested in the civil service commission and City departments pursuant to the City Charter.
- E. By enacting this title, the City expresses its intent to ensure that Spokane generally, as well as the City itself, is free from bias or discrimination on the basis of race, religion, creed, color, sex, national origin, marital status, familial status, housing status, domestic violence victim status, age, sexual orientation, gender identity, honorably discharged veteran or military status, refugee status, the presence of any sensory, mental or physical disability as defined by the Americans with Disabilities Act and/or the Washington State Law Against Discrimination, and free from sexual harassment.
- F. Nothing in this chapter shall constitute a cause of action under state law or form a basis for relief in the state courts. It is the intent of this chapter that all causes of action for violations of the chapter shall lie with the City of Spokane's Hearing Examiner, Municipal Court, or Superior Court, as specified in this Title 18.
- G. Nothing in this Title 18 shall be deemed to deny any person the right to institute any action or to pursue any civil or criminal remedy for the violation of such person's civil rights. Nothing in this Title 18 shall limit or expand any cause of action available to any person under federal or state law.

Section 4. That section 18.01.030 of the Spokane Municipal Code is amended to read as follows:

Section 18.01.030 Definitions

- A. "Commission" means the Spokane Human Rights Commission.
- B. "Data management protocols" means the procedures governing how data collected by surveillance equipment will be retained, stored, indexed and accessed. Information comprising data management protocols includes, at a minimum, the information required in SMC 18.04.020.
- C. "Disability" means the presence of a sensory, mental, or physical impairment that, whether temporary or permanent, common or uncommon, mitigated or unmitigated, a limitation or not on the ability to work generally or work at a particular job, or a limitation or not on the ability to engage in any other activity within the scope of this Title 18:

1. is medically cognizable or diagnosable; or
 2. exists as a record or history; or
 3. is perceived to exist whether or not it exists in fact.
 4. For the purposes of reasonable accommodation in employment, an impairment must be known or shown through an interactive process to exist in fact and:
 - a. The impairment must have a substantially limiting effect upon the individual's ability to perform his or her job, the individual's ability to apply or be considered for a job, or the individual's access to equal benefits, privileges, or terms or conditions of employment; or
 - b. The employee must have put the employer on notice of the existence of an impairment, and medical documentation must establish a reasonable likelihood that engaging in job functions without an accommodation would aggravate the impairment to the extent that it would create a substantially limiting effect.
 5. For purposes of this definition, a limitation is not substantial if it has only a trivial effect.
 6. For purposes of housing, a "reasonable accommodation" is an adjustment to a rule, policy, practice, or service that may be necessary for a person with a disability to have an equal opportunity to use and enjoy a dwelling, including public and common use spaces, where there is an identifiable relationship or nexus between the requested accommodation and the person's disability.
- D. "Discrimination" means different or unequal treatment because of race, religion, creed, color, sex, national origin, marital status, familial status, housing status, domestic violence victim status, age, sexual orientation, gender identity, honorably discharged veteran or military status, refugee status, disability, the use of a guide dog or service animal, or the use or eligibility for the use of housing choice or other subsidy program or alternative source of income. "Discriminate" means to treat differently or unequally because of race, religion, creed, color, sex, national origin, marital status, familial status, housing status, domestic violence victim status, age, sexual orientation, gender identity, honorably discharged veteran or military status, refugee status, the presence of any sensory, mental or physical disability as defined by the Americans with Disabilities Act and/or the Washington State Law Against Discrimination, or the use or eligibility for the use of housing choice or

other subsidy program or alternative source of income. For purposes of this definition, it is discriminatory to fail to offer reasonable accommodation in housing or employment to an otherwise qualified applicant or employee with a disability, absent a showing that the accommodation would impose an undue hardship.

- E. “Dog guide” means a dog that is specifically trained for the purpose of guiding persons who are blind or a dog trained for the purpose of assisting persons with disabilities.
- F. “Domestic Violence Victim Status” means a family or household member, as defined in RCW 10.99.020 (3), who has been subjected to domestic violence as defined in RCW 10.99.020 (5) or who is a victim of sexual assault as defined in RCW 70.125.030.
- G. “Employee” means an individual who works for wages, salary or commission, or a combination thereof, in the service of an employer, but does not include a person employed by a parent, grandparent, brother, sister, spouse or child. The term includes an individual who is seeking or applying for employment. This definition does not include independent contractors.
- H. “Employer” means any person acting in the interest of an employer, directly or indirectly, who employs employees within the City, or who solicits individuals within the City to apply for employment within the City, including the City of Spokane and all its boards, commissions and authorities.
- I. “Entities under common ownership” means two or more legal entities, such as corporations, limited liability companies, partnerships, and the like which are: owned by the same person(s); in which the same person(s) serve as officers and/or directors; or the majority of one of which is owned by one or more of the others. For example, if a single person owns controlling interests in several limited liability companies, all of those limited liability companies are entities under common ownership.
- J. “Family with children status” means one or more individuals who have not attained the age of eighteen years being domiciled with a parent or another person having legal custody of such individual or individuals, or with the designee of such parent or other person having such legal custody, with the written permission of such parent or other person. Families with children status also applies to any person who is pregnant or is in the process of securing legal custody of any individual who has not attained the age of eighteen years.
- K. “Federally-recognized tribe” means an entity listed on the Department of the Interior's list under the Federally Recognized Indian Tribe List Act of 1994, which

the Secretary currently acknowledges as an Indian tribe and with which the United States maintains a government-to-government relationship.

- L. "Gender Identity" means having or being perceived as having a gender identity, self-image, appearance, behavior, or expression, whether or not that gender identity, self-image, appearance, behavior, or expression is different from that traditionally associated with the sex assigned to that person at birth.
- M. "Housing choice or other subsidy program((or alternative source of income))" means, without limitation: (i) any short or long term federal, state or local government, private nonprofit, or other assistance program in which a tenant's rent is paid either partially by the program (through a direct arrangement between the program and the owner or lessor of the real property), and partially by the tenant or completely by the program; or (ii) HUD-Veteran Affairs Supportive Housing (VASH) vouchers, Housing and Essential Needs (HEN) funds, and short-term rental assistance provided by Rapid Rehousing subsidies.
- N. "Housing status" means the status of having or not having a fixed or regular residence, including the status of being homeless or unhoused, living on the streets, in a shelter, or in a temporary residence.
- O. "Impairment" includes, without limitation, any:
 - 1. physiological disorder, or condition, cosmetic disfigurement, or anatomical loss affecting one or more of the following body systems: Neurological, musculoskeletal, special sense organs, respiratory, including speech organs, cardiovascular, reproductive, digestive, genitor-urinary, hemic and lymphatic, skin and endocrine; or
 - 2. mental, developmental, traumatic, or psychological disorder, including but not limited to cognitive limitation, organic brain syndrome, emotional or mental illness, and specific learning disabilities.
- P. "Income" means lawful, verifiable income derived from all sources, including without limitation wages, salaries or other compensation for employment; Social Security benefits; supplemental security income; unemployment benefits; retirement programs; child support; payments from the Aged, Blind or Disabled Cash Assistance Program; Refugee Cash Assistance; any federal, state, local government, private, or nonprofit-administered benefit program, including without limitation payments from any housing choice or other subsidy program as defined in this chapter; financial aid for college students; and per capita payments or distributions received from a federally-recognized tribe.

- Q. "Labor organization" means an organization which is constituted for the purpose, in whole or in part, of collective bargaining or for dealing with an employer concerning grievances, terms or conditions of employment, or for other mutual aid or protection in connection with an employer.
- R. "Marital status" means the status of being married, single, separated, divorced or widowed.
- S. "National origin" includes ancestry.
- T. "Operational protocols" means the procedures governing how and when surveillance equipment may be used and by whom and includes, at a minimum, the information required in SMC 18.04.010.
- U. "Person" includes:
1. A natural individual, partnership, association, organization, corporation, cooperative, legal representative, trustee and receiver, and any group of persons acting in concert;
 2. an owner, lessee, proprietor, manager, agent or employee, of a person, whether consisting of one or more natural persons;
 3. entities under common ownership; and
 4. any political or civil subdivisions of the City and any agency or instrumentality of the City or of any political or civil subdivision thereof.

This definition does not include the federal government or any federally-recognized tribe.

- V. "Place of public resort, accommodation, assemblage or amusement" includes, but is not limited to, any place, licensed or unlicensed, kept for gain, hire or reward, or where charges are made for admission, service, occupancy, or use of any property or facilities, whether conducted for the entertainment, housing, or lodging of transient guests, or for the benefit, use, or accommodation of those seeking health, recreation, or rest, or for the burial or other disposition of human remains, or for the sale of goods, merchandise, services, or personal property, or for the rendering of personal services, or for public conveyance or transportation on land, water or in the air, including the stations and terminals thereof and the garaging of vehicles, or where food or beverages of any kind are sold for consumption on the premises, or where public amusement, entertainment, sports, or recreation of any kind is offered with or without charge, or where medical service or care is made available, or where the public gathers, congregates, or assembles for amusement, recreation, or public purposes, or public halls, public elevators, and public

washrooms of buildings and structures occupied by two or more tenants, or by the owner and one or more tenants, or any public library or educational institution, or schools of special instruction, or nursery schools, or day care centers or children's camps, provided that nothing contained in this definition shall be construed to include or apply to any institute, bona fide club, or place of accommodation, which is by its nature distinctly private, including fraternal organizations, though where public use is permitted that use shall be covered by this section; nor shall anything contained in this definition apply to any educational facility, columbarium, crematory, mausoleum, or cemetery operated or maintained by a bona fide religious or sectarian institution.

- W. "Profiling" means actions of the Spokane Police Department, its members, or officers commissioned by the Spokane Police Department to rely on actual or perceived race, religion, national origin, color, creed, age, citizenship status, immigration status, refugee status, gender, sexual orientation, gender identity, disability, socio-economic status, housing status, or membership in any protected class under federal, state or local law as the determinative factor in initiating law enforcement action against an individual, rather than an individual's behavior or other information or circumstances that links a person or persons to suspected unlawful activity.
- X. "Refugee status" means the status of a person who, under the provisions of 8 USC 1101(a)(42), is outside a country of that person's nationality or, in the case of a person having no nationality, is outside any country in which that person last habitually resided, and who is unable or unwilling to return to, and is unable or unwilling to avail himself or herself of the protection of, that country because of persecution or a well-founded fear of persecution on account of race, religion, nationality, membership in a particular social group, or political opinion.
- Y. "Service animal" means an animal that is trained for the purposes of assisting or accommodating a person with a disability.
- Z. "Sex" means gender.
- AA. "Sexual orientation" means heterosexuality, homosexuality, bisexuality and gender expression or identity. As used in this definition, "gender expression or identity" means having or being perceived as having a gender identity, self-image, appearance, behavior, or expression, whether or not that gender identity, self-image, appearance, behavior, or expression is different from that traditionally associated with the sex assigned to that person at birth.
- BB. "Surveillance equipment" means equipment capable of capturing or recording data, including images, videos, photographs or audio operated by or at

the direction of a City department that may deliberately or inadvertently capture activities of individuals on public or private property, regardless of whether "masking" or other technology might be used to obscure or prevent the equipment from capturing certain views. "Surveillance equipment" includes drones or unmanned aircraft and any attached equipment used to collect data. "Surveillance equipment" does not include the following equipment which are in use by the City of Spokane as of March 1, 2017:

1. handheld or body-worn devices (e.g., "bodycams") used by law enforcement;
2. cameras installed in or on a police vehicle (e.g., "dashcams");
3. cameras installed in or on any City-owned vehicle, including without limitation fire trucks, emergency vehicles, utility vehicles and street maintenance vehicles, which are intended to ensure the safe operation of the vehicle;
4. cameras installed along a public right-of-way to record traffic patterns and/or traffic violations;
5. cameras intended to record activity inside or at the entrances to City buildings for security purposes; or
6. cameras installed to monitor and protect the physical integrity of City infrastructure, including without limitation fire stations and utility service facilities.

Section 5. That there is enacted a new section 18.05.040 of the Spokane Municipal Code to read as follows:

Section 18.05.040 Human Rights of Individuals Experiencing Homelessness

No person's rights, privileges, or access to public services and accommodations may be denied or abridged in violation of applicable laws solely because of their housing status. Such a person shall enjoy the same rights, privileges, and responsibilities as any other resident of the City of Spokane. A person experiencing homelessness:

1. Has the right to use and move freely in public spaces, including, but not limited to, public sidewalks, public parks, public transportation, and public buildings in the same manner as any other person, and without discrimination on the basis of the person's housing status, and while in public spaces such persons shall be subject to the same applicable rules and regulations regarding the use or occupancy of such space and property;

2. Has the right to equal treatment by all municipal agencies, without discrimination on the basis of housing status;
3. Has the right not to face discrimination while seeking or maintaining employment in the City of Spokane based on the person's housing status, lack of permanent mailing address, or having a mailing address of a shelter or social service provider unless the individual's housing status has a bona fide and legitimate relation to the primary duties of the job;
4. Has the right to be free from unreasonable searches of their person or property when seeking or receiving homelessness services, including shelter services; and
5. Has the right to retain control of their personal papers and other essential personal property when seeking or receiving homelessness services, including shelter services.

Section 6. Severability. If any section, subsection, sentence, clause, phrase or word of this ordinance should be held to be invalid or unconstitutional by a court of competent jurisdiction, such invalidity or unconstitutionality thereof shall not affect the validity or constitutionality of any other section, subsection, sentence, clause, phrase or word of this ordinance.

Section 7. Clerical Errors. Upon approval by the city attorney, the city clerk is authorized to make necessary corrections to this ordinance, including scrivener's errors or clerical mistakes; references to other local, state, or federal laws, rules, or regulations; or numbering or referencing of ordinances or their sections and subsections.

PASSED by the City Council on _____.

Council President

Attest:

Approved as to form:

City Clerk

Assistant City Attorney

Mayor

Date

Effective Date

Strike the entirety of the ordinance and substitute the following in its place:

ORDINANCE NO. C-36549

An ordinance relating to the human rights and basic dignity of individuals experiencing homelessness; amending sections 18.01.010, 18.01.020, 18.01.030, 18.01.050, 18.02.010 and 18.03.010 of the Spokane Municipal Code; and enacting a new Section 18.05.040 of the Spokane Municipal Code.

WHEREAS, the City of Spokane knows the issue of homelessness is one of the most pressing and complex situations encountered by our society; and

WHEREAS, in developing public policy to address homelessness, emphasis should be given to attending to the basic needs of the homeless and unhoused while preserving the dignity of these individuals in their circumstances; and

WHEREAS, unhoused and homeless individuals represent a diverse range of ages, education and backgrounds, and vary in their unmet basic needs, talents and dreams, and but all are possessed of inner and outer strengths that can be harnessed to improve their situation and benefit society as a whole; and

WHEREAS, homelessness threatens healthy community living among people, and as it grows it can generate and heighten attitudes of insensitivity, contempt, harshness, shunning, and

WHEREAS, the basic human and legal rights of the unhoused and homeless are frequently infringed because of such attitudes; and

WHEREAS, respect for the dignity of human beings and equality before the law are principles which are fundamental and nonexpendable to guarantee the common good and healthy community living as a people; and

WHEREAS, the City of Spokane should reassert its commitment to the constitutional principle that all people are equal before the law and that there must be no discrimination whatsoever on the basis of protected status as recognized in state and federal law, and in the Spokane Municipal Code; and

NOW THEREFORE, the City of Spokane does ordain:

Section 1. That section 18.01.010 of the Spokane Municipal Code is amended to read as follows:

Section 18.01.010 Findings

The City of Spokane finds that discrimination based on race, religion, creed, color, sex, national origin, marital status, familial status, housing status, domestic violence victim status, age, sexual orientation, gender identity, honorably discharged veteran or military status, refugee status, the presence of any sensory, mental or physical disability as defined by the Americans with Disabilities Act, 42 U.S.C. § 12101 et seq, and/or the Washington State Law Against Discrimination, Chapter 49.60 RCW, or the receipt of, or eligibility for the receipt of, funds from any housing choice or other subsidy program or alternative source of income poses a substantial threat to the health, safety and general welfare of the citizens of Spokane. The City deems it necessary and proper to enact a local ordinance to address these issues.

Section 2. That section 18.01.020 of the Spokane Municipal Code is amended to read as follows:

Section 18.01.020 Purpose and Intent

- A. The City values the dignity and worth of all human beings and is committed to promoting justice, equity and an inclusive environment for all by respecting cultural and individual diversity and fostering mutual understanding among all people regardless of race, religion, creed, color, sex, national origin, marital status, familial status, housing status, domestic violence victim status, age, sexual orientation, gender identity, honorably discharged veteran or military status, refugee status, the presence of any sensory, mental or physical disability as defined by the Americans with Disabilities Act and/or the Washington State Law Against Discrimination, or the receipt of, or eligibility for the receipt of, funds from any housing choice or other subsidy program or alternative source of income.
- B. It is the intent of the City that all people have an equal opportunity to participate fully in the life of the City and that discriminatory barriers to equal participation in employment, housing, and public accommodations be removed. The City has a compelling interest in eradicating and preventing such discrimination and in ensuring equal opportunity in employment, housing, and public accommodations. This Title 18 represents the least restrictive means of achieving the City's objectives.
- C. The provisions of this Title 18 are to be broadly and liberally construed to effectuate this Title's remedial purpose and the City's legislative intent.
- D. These sections are not intended to establish or require affirmative action or quotas of any kind, or to infringe upon the authority vested in the civil service commission and City departments pursuant to the City Charter.
- E. By enacting this title, the City expresses its intent to ensure that Spokane generally, as well as the City itself, is free from bias or discrimination on the basis of race, religion, creed, color, sex, national origin, marital status, familial status, housing status, domestic violence victim status, age, sexual orientation, gender identity, honorably discharged veteran or military status, refugee status, the presence of any sensory, mental or physical

disability as defined by the Americans with Disabilities Act and/or the Washington State Law Against Discrimination, and free from sexual harassment.

- F. Nothing in this chapter shall constitute a cause of action under state law or form a basis for relief in the state courts. It is the intent of this chapter that all causes of action for violations of the chapter shall lie with the City of Spokane's Hearing Examiner, Municipal Court, or Superior Court, as specified in this Title 18.
- G. Nothing in this Title 18 shall be deemed to deny any person the right to institute any action or to pursue any civil or criminal remedy for the violation of such person's civil rights. Nothing in this Title 18 shall limit or expand any cause of action available to any person under federal or state law.

Section 3. That section 18.01.030 of the Spokane Municipal Code is amended to read as follows:

Section 18.01.030 Definitions

- A. "Commission" means the Spokane Human Rights Commission.
- B. "Comprehensive Support Services" means services encompassing addiction recovery services, resource distribution centers, congregate shelters, transitional or non-permanent housing. Such services include, but are not limited to, behavioral health services providers as defined in RCW 71.05.020.
- ~~(B)~~ C. "Data management protocols" means the procedures governing how data collected by surveillance equipment will be retained, stored, indexed and accessed. Information comprising data management protocols includes, at a minimum, the information required in SMC 18.04.020.
- ~~(C)~~ D. "Disability" means the presence of a sensory, mental, or physical impairment that, whether temporary or permanent, common or uncommon, mitigated or unmitigated, a limitation or not on the ability to work generally or work at a particular job, or a limitation or not on the ability to engage in any other activity within the scope of this Title 18:
 - 1. is medically cognizable or diagnosable; or
 - 2. exists as a record or history; or
 - 3. is perceived to exist whether or not it exists in fact.
 - 4. For the purposes of reasonable accommodation in employment, an impairment must be known or shown through an interactive process to exist in fact and:
 - a. The impairment must have a substantially limiting effect upon the individual's ability to perform his or her job, the individual's ability to apply

or be considered for a job, or the individual's access to equal benefits, privileges, or terms or conditions or employment; or

- b. The employee must have put the employer on notice of the existence of an impairment, and medical documentation must establish a reasonable likelihood that engaging in job functions without an accommodation would aggravate the impairment to the extent that it would create a substantially limiting effect.
5. For purposes of this definition, a limitation is not substantial if it has only a trivial effect.
 6. For purposes of housing, a "reasonable accommodation" is an adjustment to a rule, policy, practice, or service that may be necessary for a person with a disability to have an equal opportunity to use and enjoy a dwelling, including public and common use spaces, where there is an identifiable relationship or nexus between the requested accommodation and the person's disability.

~~((D))~~ E. "Discrimination" means different or unequal treatment because of race, religion, creed, color, sex, national origin, marital status, familial status, housing status, domestic violence victim status, age, sexual orientation, gender identity, honorably discharged veteran or military status, refugee status, disability, the use of a guide dog or service animal, or the use or eligibility for the use of housing choice or other subsidy program or alternative source of income. "Discriminate" means to treat differently or unequally because of race, religion, creed, color, sex, national origin, marital status, familial status, housing status, domestic violence victim status, age, sexual orientation, gender identity, honorably discharged veteran or military status, refugee status, the presence of any sensory, mental or physical disability as defined by the Americans with Disabilities Act and/or the Washington State Law Against Discrimination, or the use or eligibility for the use of housing choice or other subsidy program or alternative source of income. For purposes of this definition, it is discriminatory to fail to offer reasonable accommodation in housing or employment to an otherwise qualified applicant or employee with a disability, absent a showing that the accommodation would impose an undue hardship.

~~((E))~~ F. "Dog guide" means a dog that is specifically trained for the purpose of guiding persons who are blind or a dog trained for the purpose of assisting persons with disabilities.

~~((F))~~ G. "Domestic Violence Victim Status" means a family or household member, as defined in RCW 10.99.020 (3), who has been subjected to domestic violence as defined in RCW 10.99.020 (5) or who is a victim of sexual assault as defined in RCW 70.125.030.

~~((G))~~ H. "Employee" means an individual who works for wages, salary or commission, or a combination thereof, in the service of an employer, but does not include a person employed by a parent, grandparent, brother, sister, spouse or child. The term includes an

individual who is seeking or applying for employment. This definition does not include independent contractors.

((H)) I. “Employer” means any person acting in the interest of an employer, directly or indirectly, who employs employees within the City, or who solicits individuals within the City to apply for employment within the City, including the City of Spokane and all its boards, commissions and authorities.

((I)) J. “Entities under common ownership” means two or more legal entities, such as corporations, limited liability companies, partnerships, and the like which are: owned by the same person(s); in which the same person(s) serve as officers and/or directors; or the majority of one of which is owned by one or more of the others. For example, if a single person owns controlling interests in several limited liability companies, all of those limited liability companies are entities under common ownership.

((J)) K. “Family with children status” means one or more individuals who have not attained the age of eighteen years being domiciled with a parent or another person having legal custody of such individual or individuals, or with the designee of such parent or other person having such legal custody, with the written permission of such parent or other person. Families with children status also applies to any person who is pregnant or is in the process of securing legal custody of any individual who has not attained the age of eighteen years.

((K)) L. “Federally-recognized tribe” means an entity listed on the Department of the Interior’s list under the Federally Recognized Indian Tribe List Act of 1994, which the Secretary currently acknowledges as an Indian tribe and with which the United States maintains a government-to-government relationship.

((L)) M. “Gender Identity” means having or being perceived as having a gender identity, self-image, appearance, behavior, or expression, whether or not that gender identity, self-image, appearance, behavior, or expression is different from that traditionally associated with the sex assigned to that person at birth.

((M)) N. “Housing choice or other subsidy program((or alternative source of income))” means, without limitation: (i) any short or long term federal, state or local government, private nonprofit, or other assistance program in which a tenant’s rent is paid either partially by the program (through a direct arrangement between the program and the owner or lessor of the real property), and partially by the tenant or completely by the program; or (ii) HUD-Veteran Affairs Supportive Housing (VASH) vouchers, Housing and Essential Needs (HEN) funds, and short-term rental assistance provided by Rapid Rehousing subsidies.

O. “Housing status” means the status of having or not having a fixed or regular residence, including, but not limited to, the status of being homeless or unhoused, living on the streets, living in an automobile or in a shelter or a temporary residence.

((N)) P. “Impairment” includes, without limitation, any:

1. physiological disorder, or condition, cosmetic disfigurement, or anatomical loss affecting one or more of the following body systems: Neurological, musculoskeletal, special sense organs, respiratory, including speech organs, cardiovascular, reproductive, digestive, genitor-urinary, hemic and lymphatic, skin and endocrine; or
2. mental, developmental, traumatic, or psychological disorder, including but not limited to cognitive limitation, organic brain syndrome, emotional or mental illness, and specific learning disabilities.

((Q)) Q. "Income" means lawful, verifiable income derived from all sources, including without limitation wages, salaries or other compensation for employment; Social Security benefits; supplemental security income; unemployment benefits; retirement programs; child support; payments from the Aged, Blind or Disabled Cash Assistance Program; Refugee Cash Assistance; any federal, state, local government, private, or nonprofit-administered benefit program, including without limitation payments from any housing choice or other subsidy program as defined in this chapter; financial aid for college students; and per capita payments or distributions received from a federally-recognized tribe.

((P)) R. "Labor organization" means an organization which is constituted for the purpose, in whole or in part, of collective bargaining or for dealing with an employer concerning grievances, terms or conditions of employment, or for other mutual aid or protection in connection with an employer.

((Q)) S. "Marital status" means the status of being married, single, separated, divorced or widowed.

((R)) T. "National origin" includes ancestry.

((S)) U. "Operational protocols" means the procedures governing how and when surveillance equipment may be used and by whom and includes, at a minimum, the information required in SMC 18.04.010.

((T)) V. "Person" includes:

1. A natural individual, partnership, association, organization, corporation, cooperative, legal representative, trustee and receiver, and any group of persons acting in concert;
2. an owner, lessee, proprietor, manager, agent or employee, of a person, whether consisting of one or more natural persons;
3. entities under common ownership; and
4. any political or civil subdivisions of the City and any agency or instrumentality of the City or of any political or civil subdivision thereof.

This definition does not include the federal government or any federally-recognized tribe.

((U)) W. "Place of public resort, accommodation, assemblage or amusement" includes, but is not limited to, any place, licensed or unlicensed, kept for gain, hire or reward, or where charges are made for admission, service, occupancy, or use of any property or facilities, whether conducted for the entertainment, housing, or lodging of transient guests, or for the benefit, use, or accommodation of those seeking health, recreation, or rest, or for the burial or other disposition of human remains, or for the sale of goods, merchandise, services, or personal property, or for the rendering of personal services, or for public conveyance or transportation on land, water or in the air, including the stations and terminals thereof and the garaging of vehicles, or where food or beverages of any kind are sold for consumption on the premises, or where public amusement, entertainment, sports, or recreation of any kind is offered with or without charge, or where medical service or care is made available, or where the public gathers, congregates, or assembles for amusement, recreation, or public purposes, or public halls, public elevators, and public washrooms of buildings and structures occupied by two or more tenants, or by the owner and one or more tenants, or any public library or educational institution, or schools of special instruction, or nursery schools, or day care centers or children's camps, provided that nothing contained in this definition shall be construed to include or apply to any institute, bona fide club, or place of accommodation, which is by its nature distinctly private, including fraternal organizations, though where public use is permitted that use shall be covered by this section; nor shall anything contained in this definition apply to any educational facility, columbarium, crematory, mausoleum, or cemetery operated or maintained by a bona fide religious or sectarian institution.

((V)) X. "Profiling" means actions of the Spokane Police Department, its members, or officers commissioned by the Spokane Police Department to rely on actual or perceived race, religion, national origin, color, creed, age, citizenship status, immigration status, refugee status, gender, sexual orientation, gender identity, disability, socio-economic status, housing status, or membership in any protected class under federal, state or local law as the determinative factor in initiating law enforcement action against an individual, rather than an individual's behavior or other information or circumstances that links a person or persons to suspected unlawful activity.

((W)) Y. "Refugee status" means the status of a person who, under the provisions of 8 USC 1101(a)(42), is outside a country of that person's nationality or, in the case of a person having no nationality, is outside any country in which that person last habitually resided, and who is unable or unwilling to return to, and is unable or unwilling to avail himself or herself of the protection of, that country because of persecution or a well-founded fear of persecution on account of race, religion, nationality, membership in a particular social group, or political opinion.

((X)) Z. "Service animal" means an animal that is trained for the purposes of assisting or accommodating a person with a disability.

((Y)) AA. "Sex" means gender.

((Z)) BB. "Sexual orientation" means heterosexuality, homosexuality, bisexuality and gender expression or identity. As used in this definition, "gender expression or identity" means having or being perceived as having a gender identity, self-image, appearance, behavior, or expression, whether or not that gender identity, self-image, appearance, behavior, or expression is different from that traditionally associated with the sex assigned to that person at birth.

((AA)) CC. "Surveillance equipment" means equipment capable of capturing or recording data, including images, videos, photographs or audio operated by or at the direction of a City department that may deliberately or inadvertently capture activities of individuals on public or private property, regardless of whether "masking" or other technology might be used to obscure or prevent the equipment from capturing certain views. "Surveillance equipment" includes drones or unmanned aircraft and any attached equipment used to collect data. "Surveillance equipment" does not include the following equipment which are in use by the City of Spokane as of March 1, 2017:

1. handheld or body-worn devices (e.g., "bodycams") used by law enforcement;
2. cameras installed in or on a police vehicle (e.g., "dashcams");
3. cameras installed in or on any City-owned vehicle, including without limitation fire trucks, emergency vehicles, utility vehicles and street maintenance vehicles, which are intended to ensure the safe operation of the vehicle;
4. cameras installed along a public right-of-way to record traffic patterns and/or traffic violations;
5. cameras intended to record activity inside or at the entrances to City buildings for security purposes; or
6. cameras installed to monitor and protect the physical integrity of City infrastructure, including without limitation fire stations and utility service facilities.

Section 4. That section 18.01.050 of the Spokane Municipal Code is amended to read as follows:

Section 18.01.050 Administration

A. Initiation.

An individual claiming to be aggrieved by a practice prohibited by SMC 18.01.040, chapter 18.02 SMC, ((e)) chapter 18.03 SMC, or SMC 18.05.040 may, within the time limit of SMC 18.01.070, file a complaint with the commission on forms made available for the purpose by commission staff.

B. Complaint.

A complaint filed by a person claiming to be aggrieved by a practice prohibited by SMC 18.01.040, chapter 18.02 SMC, ~~((€))~~ chapter 18.03 SMC, or SMC 18.05.040 shall be immediately forwarded by the commission for review by the City or an agency or organization with which the City maintains a contractual relationship for the purpose of reviewing such complaints (referred to in this section as the “reviewing agency”), to determine whether the allegations stated on the face of the complaint, if true, would be a prohibited practice as stated in SMC 18.01.040, chapter 18.02 SMC, ~~((€))~~ chapter 18.03 SMC, or SMC 18.05.040. Complaints shall be processed as follows:

1. The reviewing agency shall review the factual allegations of the complaint, interview the complainant, and take a statement from the complainant.
2. The reviewing agency then interviews the person accused of discrimination and documents that interview in a writing.
3. The reviewing agency shall also, if applicable, interview all participants and witnesses having relevant information regarding the allegation of discrimination, and document those interviews in writing.
4. If, as the result of the interviews described in subsections 1-3 of this paragraph B, the reviewing agency determines that the complaint states a violation of this chapter, the reviewing agency shall communicate that determination in writing to the complainant and the city attorney’s office, with a copy to the commission.
5. If the reviewing agency determines that the complaint does not state a violation of SMC 18.01.040, chapter 18.02 SMC, ~~((€))~~ chapter 18.03 SMC, or SMC 18.05.040, the complaint shall be dismissed immediately.
6. Complaints that claim a violation of state or federal law shall be referred to the appropriate state or federal agency.
7. Complaints that claim a violation of a prohibited practice established only in this Title 18 shall be referred to a Washington State Dispute Resolution Center established under chapter 7.75, RCW, or by a mediator agreed upon by all parties, within thirty days of the filing of the complaint. Mediation sessions are not open to the public. If the mediation resolves the complaint, the mediator will notify the City of the resolution and the complaint file will be closed.
8. Complaints that are not resolved through mediation shall be submitted to the City Prosecutor for a determination as to the filing of a civil infraction pursuant to chapter 1.05 SMC.

C. Administrative appeal.

Any person whose complaint has been dismissed pursuant to SMC 18.01.050 B(5) may appeal the dismissal to the hearing examiner, who shall review the complaint and the decision to dismiss

the complaint under an abuse of discretion standard of review. The hearing examiner may affirm the dismissal, reverse the dismissal, or remand the complaint to be processed as set forth in SMC 18.01.050(B).

D. Judicial review.

Any person who is aggrieved by the decision of the hearing examiner on administrative appeal under this section may institute an action for judicial review in the Superior Court pursuant to RCW 49.60.330.

E. The commission and its staff shall prioritize its resources to focus on resolving complaints which are not within the jurisdiction of government or non-profit agencies other than the commission.

~~((F. The City shall not take any enforcement action based on discrimination due to the use of "housing choice or other subsidy program or alternative source of income" as defined in this Title 18 before September 1, 2017. The City Council shall name an ad hoc stakeholder group to make recommendations to the City Council for amendments to Chapter 18.03 SMC, concerning the use of housing choice or other subsidy programs or alternative sources of income.))~~

Section 5. That section 18.02.010 of the Spokane Municipal Code is amended to read as follows:

Section 18.02.010 Employment

- A. No person shall discriminate by refusing to hire, employ or promote, by barring or discharging from employment, in compensation or terms, conditions or privileges of employment, unless discrimination results from a bona fide occupational requirement reasonably necessary to the normal operation of the employer's business.
- B. No person shall discriminate by printing or circulating, or by causing to be printed or circulated, any statement, advertisement or publication, or by using any employment application form, or by making an inquiry in connection with prospective employment which expresses, directly or indirectly, any discriminatory limitation or specification, unless such limitation or specification is based upon a bona fide occupational qualification reasonably necessary to the normal operation of the employer's business, or unless otherwise provided by state or federal law.
- C. No person shall discriminate by classifying or referring for employment, or by failing or refusing to refer for employment, or otherwise, unless such classification or referral results from a bona fide occupational requirement reasonably necessary to the normal operation of the employer's business, or where such classification or referral is allowed under state or federal law~~((;))~~.

D. No person shall reject or disqualify an applicant for employment solely because the individual does not have a fixed or regular residence, or because the individual is homeless or unhoused, or because the individual lives on the street, in an automobile, in a shelter, or in a temporary residence, unless the individual's housing status has a bona fide and legitimate relation to the primary duties of the job and such rejection or disqualification does not otherwise violate state or federal employment laws or regulations.

Section 6. That section 18.03.010 of the Spokane Municipal Code is amended to read as follows:

Section 18.03.010 Prohibited Practices

- A. It is a violation of this chapter for any person to discriminate by:
1. refusing to sell, lease, rent or otherwise make available any offered real property;
 2. expelling a purchaser, lessee or renter from any real property;
 3. altering the price, terms, conditions or privileges relating to the sale, rental, lease or occupancy of real property, or in the furnishing of any facilities or services in connection with real property;
 4. attempting to discourage the sale, rental or lease of any real property to a purchaser, lessee or renter;
 5. publishing, circulating, issuing or displaying, or causing to be published, circulated, issued or displayed, any communication, notice, advertisement or sign of any kind relating to the sale, rental or lease of real property which indicates any preference, limitation or specification with respect thereto;
 6. assisting, inducing, compelling or coercing another person to commit an act or engage in a practice that violates this subsection;
 7. coercing, intimidating, threatening or interfering with any person in the exercise or enjoyment of, or on account of having aided or encouraged any other person in the exercise of, any right granted or protected by this subsection.
- B. No person whose business includes engaging in residential real estate related transactions may discriminate in making available or in the terms and conditions of such a transaction. "Residential real estate related transaction" means the making or purchasing of loans or providing other financial assistance for purchasing, construction, improving, repairing or maintaining a dwelling or securing residential real estate, or the selling, brokering or appraising of residential real property.
- C. No real estate licensee may accept or retain a listing of real property for sale, lease or rental with an understanding that a purchaser may be discriminated against with respect to the sale, rental or lease.

- D. No person may for profit induce or attempt to induce any other person to sell or rent any dwelling by representations regarding entry or prospective entry into the neighborhood of a person or person of a particular race, religion, creed, color, sex, national origin, marital status, familial status, housing status, domestic violence victim status, age, sexual orientation, gender identity, honorably discharged veteran or military status, refugee status, or the presence of any sensory, mental or physical disability as defined by the American with Disabilities Act and/or the Washington State Law Against Discrimination, Chapter 49.60 RCW.

Section 7. That there is enacted a new section 18.05.040 of the Spokane Municipal Code to read as follows:

Section 18.05.040 Human Rights of Individuals Experiencing Homelessness

No person's rights, privileges, or access to public services and accommodations may be denied or abridged in violation of applicable laws solely because of their housing status. Such a person shall enjoy the same rights, privileges, and responsibilities as any other resident of the City of Spokane. A person experiencing homelessness:

1. Has the right to use and move freely in public spaces, including, but not limited to, public sidewalks, public parks, public transportation, and public buildings in the same manner as any other person, and without discrimination on the basis of the person's housing status, and while in public spaces such persons shall be subject to the same applicable rules and regulations regarding the use or occupancy of such space and property;
2. Has the right to equal treatment by all municipal agencies, without discrimination on the basis of housing status;
3. Has the right not to face discrimination while seeking or maintaining employment in the City of Spokane based on the person's housing status, lack of permanent mailing address, or having a mailing address of a shelter or social service provider unless the individual's housing status has a bona fide and legitimate relation to the primary duties of the job;
4. Has the right to be free from unreasonable searches of their person or property when seeking or receiving comprehensive support services, including shelter services; and
5. Has the right to retain control of their personal papers and other essential personal property when seeking or receiving comprehensive support services, including shelter services.

Section 6. Severability. If any section, subsection, sentence, clause, phrase or word of this ordinance should be held to be invalid or unconstitutional by a court of competent jurisdiction, such invalidity or unconstitutionality thereof shall not affect the validity or constitutionality of any other section, subsection, sentence, clause, phrase or word of this ordinance.

Section 7. Clerical Errors. Upon approval by the city attorney, the city clerk is authorized to make necessary corrections to this ordinance, including scrivener's errors or clerical mistakes; references to other local, state, or federal laws, rules, or regulations; or numbering or referencing of ordinances or their sections and subsections.

PASSED by the City Council on _____.

Council President

Attest:

Approved as to form:

City Clerk

Assistant City Attorney

Mayor

Date

Effective Date

Strike the entirety of the ordinance and substitute the following in its place:

ORDINANCE NO. C-36549

An ordinance expanding fair chance hiring practices, amending sections 9.02.010 through 9.02.050 of the Spokane Municipal Code, and amending sections 9.03.010 and 9.03.020 of the Spokane Municipal Code.

WHEREAS, the City of Spokane knows the issue of homelessness is one of the most pressing and complex situations encountered by our society; and

WHEREAS, in developing public policy to address homelessness, emphasis should be given to attending to the basic needs of the homeless and unhoused while preserving the dignity of these individuals in their circumstances; and

WHEREAS, unhoused and homeless individuals represent a diverse range of ages, education and backgrounds, and vary in their unmet basic needs, talents and dreams, and but all are possessed of inner and outer strengths that can be harnessed to improve their situation and benefit society as a whole; and

WHEREAS, respect for the dignity of human beings and equality before the law are principles which are fundamental and nonexpendable to guarantee the common good and healthy community living as a people; and

WHEREAS, the City of Spokane should reassert its commitment to the constitutional principle that all people are equal before the law;

WHEREAS, homeless individuals are typically at a disadvantage when applying for employment due to the stigma of homelessness and practical obstacles to obtaining employment, such as a lack of fixed address; and

WHEREAS, the City of Spokane wishes to remove unfair barriers to employment of homeless individuals,

NOW THEREFORE, the City of Spokane does ordain:

Section 1. That section 9.02.010 of the Spokane Municipal Code is amended to read as follows:

[Section 09.02.010](#) Findings

The City of Spokane finds that many qualified job applicants who have some kind of criminal record simply cannot obtain employment due to early screening or advertising which excludes them from the applicant pool. Many individuals who have criminal records could show themselves to be both highly-qualified and well-suited for employment in an interview, yet many do not even reach that stage due to screening criteria which make those with criminal records immediately

ORD C36549 (CATHCART AMENDMENT) (08-08-24)

disqualified for work. People with criminal records who cannot find work are forced to rely on public assistance and may be more likely than those who can secure work to re-offend.

The City of Spokane further finds that some individuals experiencing homelessness have faced barriers in seeking employment that arise from their housing status. In considering the City's investments and commitments to reducing the impacts of homelessness on the community and considering that the greatest way out of homelessness is a job, dignity, and purpose. The city has determined that employment discrimination solely based on housing status cannot be allowed.

Section 2. That section 9.02.020 of the Spokane Municipal Code is amended to read as follows:

Section 09.02.020 Purpose

- A. The City of Spokane intends to ensure that people who have completed a sentence for a past criminal conviction are not forever branded as unworthy or unable to participate in the life of the community, a central part of which is the ability to compete for employment in Spokane.
- B. The City of Spokane intends to also ensure that housing status does not brand individuals as unworthy or unable to participate in the life of the community, a central part of which is the ability to compete for employment in Spokane.
- ~~((B))~~ C. The City intends to ensure that all employers have clear guidance on when they can inquire about criminal records of job applicants, in an effort to provide predictability, certainty, and fairness to both employers and job applicants.
- ~~((C))~~ D. The City intends to assure employers that they may still conduct criminal background checks necessary for their specific employment purposes, and to set certain minimum and non-intrusive standards for doing so.
- ~~((D))~~ E. Nothing contained in this chapter is intended to be nor shall be construed to create or form the basis for any liability on the part of the City, or its officers, employees or agents for any injury or damage resulting from or by reason of any act or omission in connection with the implementation or enforcement of this chapter on the part of the City by its officers, employees or agents.
- ~~((E))~~ F. Nothing in this chapter shall constitute or be construed to create a private right of action under state law or form a basis for relief in the state courts. It is the intent of this chapter that all causes of action for violations of the chapter shall lie with the City of Spokane municipal court.
- ~~((F))~~ G. Nothing in this chapter shall be deemed to deny any person the right to institute any action or to pursue any civil or criminal remedy for the violation of such person's civil rights.

ORD C36549 (CATHCART AMENDMENT) (08-08-24)

Section 3. That section 9.02.030 of the Spokane Municipal Code is amended to read as follows:

Section 09.02.030 Definitions

- A. "Arrest or Conviction Record" means any record or information about a citation or arrest for criminal conduct, including records relating to probable cause to arrest, and includes any record about a criminal or juvenile case filed with any court, whether or not such a case resulted in a finding of guilt, has been vacated, or overturned on appeal.
- B. "Employment" means any individual occupation, vocation, job, or work for pay, including temporary or seasonal work, and work through the services of a temporary or other employment agency.
- C. "Employer" means any individual, partnership, association, corporation, business trust, contractor, temporary staffing agency, training and apprenticeship program, job placement, referral and employment agency, or any person or group of persons acting directly or indirectly and within the city limits of Spokane, in the interest of an employer in relation to an employee; provided, however, that the term "employer" does not include: (i) the City of Spokane (which is covered under chapter 09.03, SMC); (ii) the United States, any agency or instrumentality of the United States, or any corporation wholly owned by the government of the United States; (iii) the State of Washington; (iv) Spokane County; or (v) any federally-recognized Indian tribe.
- D. "Homelessness" means not having a fixed or regular residence, including the state of being homeless or unhoused, living on the streets, in a shelter, or in a temporary residence.
- E. "Housing status" means the question whether a specific individual is experiencing homelessness.
- ~~(D)~~ F. "Otherwise qualified" means that the applicant meets the basic criteria for the position as set out in the advertisement or job description without taking into account the existence or absence of a criminal conviction or arrest record.

Section 4. That section 9.02.040 of the Spokane Municipal Code is amended to read as follows:

Section 09.02.040 Applicability

- A. This chapter does not apply:
 - 1. to any employer hiring an employee who will have unsupervised access to children under the age of eighteen, a vulnerable adult as defined in RCW 74.34.020(21), or a vulnerable person as defined in RCW 9.96A.060;
 - 2. to employers who are expressly permitted or required under any federal or Washington state law to inquire into, consider, or rely on information about an applicant's arrest or conviction record for employment purposes;
 - 3. to any General Authority Washington law enforcement agency as defined in RCW 10.93.020(1); or

ORD C36549 (CATHCART AMENDMENT) (08-08-24)

4. where criminal background checks are specifically permitted or required under state or federal law.
- B. Nothing in this chapter shall be construed to protect criminal conduct.
- C. Nothing in this chapter shall be interpreted or applied as imposing an obligation on the part of an employer to provide accommodations or job modifications in order to facilitate the employment or continued employment of an applicant with an arrest or conviction record or who is facing pending criminal charges.
- ~~(G)~~ D. Nothing in this chapter prohibits an employer from declining to hire an applicant with a criminal record or from terminating the employment of an employee with a criminal record.
- E. Nothing in this chapter shall be interpreted or applied as imposing an obligation on the part of an employer to provide accommodations or job modifications in order to facilitate the employment or continued employment of an individual experiencing homelessness.
- F. Nothing in this chapter prohibits an employer from declining to hire an applicant experiencing homelessness or from terminating the employment of an employee experiencing homelessness.

Section 5. That section 9.02.050 of the Spokane Municipal Code is amended to read as follows:

Section 09.02.050 Prohibition

- A. No employer shall:
1. advertise applicable employment openings in a way that excludes people with arrest or conviction records from applying, such as using advertisements which state “no felons,” “no criminal background,” or which otherwise convey similar messages; provided, employers may advertise the requirement for a criminal history inquiry and/or background check during or after the interview process as long as such advertisement does not state that an arrest or conviction record will automatically preclude the applicant from consideration for employment;
 2. include any question in an application for applicable employment, inquire orally or in writing, receive information through a criminal history background check, or otherwise obtain information about an applicant’s arrest or conviction record prior to an in-person, telephonic, or video interview or received a conditional offer of employment;
 3. use, distribute, or disseminate an applicant’s or employee’s arrest or conviction record except as required or otherwise allowed by law;
 4. disqualify an applicant from applicable employment prior to an in-person, telephonic, or video interview solely because of a prior arrest or conviction unless the conviction is related to significant duties of the job or disqualification is otherwise allowed by this chapter; ~~((e))~~

ORD C36549 (CATHCART AMENDMENT) (08-08-24)

5. reject or disqualify an applicant for failure to disclose a criminal record prior to initially determining the applicant is otherwise qualified for the position((-));
 6. reject or disqualify an applicant based solely on their housing status unless the individual's housing status has a bona fide and legitimate relation to the primary duties of the job and such rejection or disqualification does not otherwise violate state or federal employment laws or regulations;
 7. include any question in an application or inquire orally or in writing related to housing status; provided, it shall not be a violation of this section for an employer to include an opportunity for an applicant to provide a mailing address or other means of contacting an applicant as part of the application process.
- B. Nothing in this chapter prohibits an employer from inquiring into or obtaining information about a job applicant's criminal conviction or arrest record or background, and considering the information received regarding such record during an in-person, telephonic, or video interview, or after the conclusion of such a job interview, or after a conditional offer of employment, and using such information in a hiring decision.

Section 6. That section 09.03.010 of the Spokane Municipal Code is amended to read as follows:

Section 09.03.010 Purpose and Intent

The City of Spokane intends to ensure that its hiring practices for City employment provide applicants who are experiencing homelessness or who have criminal arrest or conviction records an equal opportunity to obtain employment with the City. ~~((This chapter is intended to implement guidance first published by the Equal Employment Opportunity Commission ("EEOC") over two decades ago and last updated in 2012, to ensure that the City of Spokane fully complies with federal law)).~~

Section 7. That section 09.03.020 of the Spokane Municipal Code is amended to read as follows:

Section 09.03.020 Statement of Policy

- A. No person may be disqualified from employment with the City due solely, or in part, to the existence of a prior criminal arrest or conviction, or prior felony conviction that occurred within the past ten (10) years, unless the crime for which the individual was convicted directly relates to the job position sought.
 - B. No person may be disqualified from employment with the City due solely, or in part, to their housing status unless it directly relates to the job position sought, or poses a potential risk to the City and its employees, residents, customers, and contractors.
- ~~((B))~~ C. The City of Spokane's use of applicant criminal arrest and conviction information will be based solely on the relationship between the past felony conviction and the potential risk to the City and its employees, residents, customers, and contractors.

ORD C36549 (CATHCART AMENDMENT) (08-08-24)

((E)) D. The City of Spokane will at all times comply with any federal or state law or regulation pertaining to background checks.

Section 8. Severability. If any section, subsection, sentence, clause, phrase or word of this ordinance should be held to be invalid or unconstitutional by a court of competent jurisdiction, such invalidity or unconstitutionality thereof shall not affect the validity or constitutionality of any other section, subsection, sentence, clause, phrase or word of this ordinance.

Section 9. Clerical Errors. Upon approval by the city attorney, the city clerk is authorized to make necessary corrections to this ordinance, including scrivener's errors or clerical mistakes; references to other local, state, or federal laws, rules, or regulations; or numbering or referencing of ordinances or their sections and subsections.

PASSED by the City Council on _____.

Council President

Attest:

Approved as to form:

City Clerk

Assistant City Attorney

Mayor

Date

Effective Date

Strike the entirety of the ordinance and substitute the following in its place:

ORDINANCE NO. C-36549

An ordinance relating to the human rights and basic dignity of individuals experiencing homelessness; amending sections 18.01.010, 18.01.020, 18.01.030, 18.01.050, 18.02.010 and 18.03.010 of the Spokane Municipal Code; and enacting a new Section 18.05.040 of the Spokane Municipal Code.

WHEREAS, the City of Spokane knows the issue of homelessness is one of the most pressing and complex situations encountered by our society; and

WHEREAS, in developing public policy to address homelessness, emphasis should be given to attending to the basic needs of the homeless and unhoused while preserving the dignity of these individuals in their circumstances; and

WHEREAS, unhoused and homeless individuals represent a diverse range of ages, education and backgrounds, and vary in their unmet basic needs, talents and dreams, and but all are possessed of inner and outer strengths that can be harnessed to improve their situation and benefit society as a whole; and

WHEREAS, homelessness threatens healthy community living among people, and as it grows it can generate and heighten attitudes of insensitivity, contempt, harshness, shunning, and

WHEREAS, the basic human and legal rights of the unhoused and homeless are frequently infringed because of such attitudes; and

WHEREAS, respect for the dignity of human beings and equality before the law are principles which are fundamental and nonexpendable to guarantee the common good and healthy community living as a people; and

WHEREAS, the City of Spokane should reassert its commitment to the constitutional principle that all people are equal before the law and that there must be no discrimination whatsoever on the basis of protected status as recognized in state and federal law, and in the Spokane Municipal Code; and

NOW THEREFORE, the City of Spokane does ordain:

Section 1. That section 18.01.010 of the Spokane Municipal Code is amended to read as follows:

Section 18.01.010 Findings

The City of Spokane finds that discrimination based on race, religion, creed, color, sex, national origin, marital status, familial status, housing status, domestic violence victim status, age, sexual orientation, gender identity, honorably discharged veteran or military status, refugee status, the presence of any sensory, mental or physical disability as defined by the Americans with Disabilities Act, 42 U.S.C. § 12101 et seq, and/or the Washington State Law Against Discrimination, Chapter 49.60 RCW, or the receipt of, or eligibility for the receipt of, funds from any housing choice or other subsidy program or alternative source of income poses a substantial threat to the health, safety and general welfare of the citizens of Spokane. The City deems it necessary and proper to enact a local ordinance to address these issues.

Section 2. That section 18.01.020 of the Spokane Municipal Code is amended to read as follows:

Section 18.01.020 Purpose and Intent

- A. The City values the dignity and worth of all human beings and is committed to promoting justice, equity and an inclusive environment for all by respecting cultural and individual diversity and fostering mutual understanding among all people regardless of race, religion, creed, color, sex, national origin, marital status, familial status, housing status, domestic violence victim status, age, sexual orientation, gender identity, honorably discharged veteran or military status, refugee status, the presence of any sensory, mental or physical disability as defined by the Americans with Disabilities Act and/or the Washington State Law Against Discrimination, or the receipt of, or eligibility for the receipt of, funds from any housing choice or other subsidy program or alternative source of income.
- B. It is the intent of the City that all people have an equal opportunity to participate fully in the life of the City and that discriminatory barriers to equal participation in employment, housing, and public accommodations be removed. The City has a compelling interest in eradicating and preventing such discrimination and in ensuring equal opportunity in employment, housing, and public accommodations. This Title 18 represents the least restrictive means of achieving the City's objectives.
- C. The provisions of this Title 18 are to be broadly and liberally construed to effectuate this Title's remedial purpose and the City's legislative intent.
- D. These sections are not intended to establish or require affirmative action or quotas of any kind, or to infringe upon the authority vested in the civil service commission and City departments pursuant to the City Charter.
- E. By enacting this title, the City expresses its intent to ensure that Spokane generally, as well as the City itself, is free from bias or discrimination on the basis of race, religion, creed, color, sex, national origin, marital status, familial status, housing status, domestic violence victim status, age, sexual orientation, gender identity, honorably discharged veteran or military status, refugee status, the presence of any sensory, mental or physical

disability as defined by the Americans with Disabilities Act and/or the Washington State Law Against Discrimination, and free from sexual harassment.

- F. Nothing in this chapter shall constitute a cause of action under state law or form a basis for relief in the state courts. It is the intent of this chapter that all causes of action for violations of the chapter shall lie with the City of Spokane's Hearing Examiner, Municipal Court, or Superior Court, as specified in this Title 18.
- G. Nothing in this Title 18 shall be deemed to deny any person the right to institute any action or to pursue any civil or criminal remedy for the violation of such person's civil rights. Nothing in this Title 18 shall limit or expand any cause of action available to any person under federal or state law.

Section 3. That section 18.01.030 of the Spokane Municipal Code is amended to read as follows:

Section 18.01.030 Definitions

- A. "Commission" means the Spokane Human Rights Commission.
- B. "Comprehensive Support Services" means services encompassing addiction recovery services, resource distribution centers, congregate shelters, transitional or non-permanent housing. Such services include, but are not limited to, behavioral health services providers as defined in RCW 71.05.020.
- ~~(B)~~ C. "Data management protocols" means the procedures governing how data collected by surveillance equipment will be retained, stored, indexed and accessed. Information comprising data management protocols includes, at a minimum, the information required in SMC 18.04.020.
- ~~(C)~~ D. "Disability" means the presence of a sensory, mental, or physical impairment that, whether temporary or permanent, common or uncommon, mitigated or unmitigated, a limitation or not on the ability to work generally or work at a particular job, or a limitation or not on the ability to engage in any other activity within the scope of this Title 18:
 - 1. is medically cognizable or diagnosable; or
 - 2. exists as a record or history; or
 - 3. is perceived to exist whether or not it exists in fact.
 - 4. For the purposes of reasonable accommodation in employment, an impairment must be known or shown through an interactive process to exist in fact and:
 - a. The impairment must have a substantially limiting effect upon the individual's ability to perform his or her job, the individual's ability to apply

or be considered for a job, or the individual's access to equal benefits, privileges, or terms or conditions or employment; or

b. The employee must have put the employer on notice of the existence of an impairment, and medical documentation must establish a reasonable likelihood that engaging in job functions without an accommodation would aggravate the impairment to the extent that it would create a substantially limiting effect.

5. For purposes of this definition, a limitation is not substantial if it has only a trivial effect.

6. For purposes of housing, a "reasonable accommodation" is an adjustment to a rule, policy, practice, or service that may be necessary for a person with a disability to have an equal opportunity to use and enjoy a dwelling, including public and common use spaces, where there is an identifiable relationship or nexus between the requested accommodation and the person's disability.

~~((D))~~ E. "Discrimination" means different or unequal treatment because of race, religion, creed, color, sex, national origin, marital status, familial status, housing status, domestic violence victim status, age, sexual orientation, gender identity, honorably discharged veteran or military status, refugee status, disability, the use of a guide dog or service animal, or the use or eligibility for the use of housing choice or other subsidy program or alternative source of income. "Discriminate" means to treat differently or unequally because of race, religion, creed, color, sex, national origin, marital status, familial status, housing status, domestic violence victim status, age, sexual orientation, gender identity, honorably discharged veteran or military status, refugee status, the presence of any sensory, mental or physical disability as defined by the Americans with Disabilities Act and/or the Washington State Law Against Discrimination, or the use or eligibility for the use of housing choice or other subsidy program or alternative source of income. For purposes of this definition, it is discriminatory to fail to offer reasonable accommodation in housing or employment to an otherwise qualified applicant or employee with a disability, absent a showing that the accommodation would impose an undue hardship.

~~((E))~~ F. "Dog guide" means a dog that is specifically trained for the purpose of guiding persons who are blind or a dog trained for the purpose of assisting persons with disabilities.

~~((F))~~ G. "Domestic Violence Victim Status" means a family or household member, as defined in RCW 10.99.020 (3), who has been subjected to domestic violence as defined in RCW 10.99.020 (5) or who is a victim of sexual assault as defined in RCW 70.125.030.

~~((G))~~ H. "Employee" means an individual who works for wages, salary or commission, or a combination thereof, in the service of an employer, but does not include a person employed by a parent, grandparent, brother, sister, spouse or child. The term includes an

individual who is seeking or applying for employment. This definition does not include independent contractors.

((H)) I. "Employer" means any person acting in the interest of an employer, directly or indirectly, who employs employees within the City, or who solicits individuals within the City to apply for employment within the City, including the City of Spokane and all its boards, commissions and authorities.

((I)) J. "Entities under common ownership" means two or more legal entities, such as corporations, limited liability companies, partnerships, and the like which are: owned by the same person(s); in which the same person(s) serve as officers and/or directors; or the majority of one of which is owned by one or more of the others. For example, if a single person owns controlling interests in several limited liability companies, all of those limited liability companies are entities under common ownership.

((J)) K. "Family with children status" means one or more individuals who have not attained the age of eighteen years being domiciled with a parent or another person having legal custody of such individual or individuals, or with the designee of such parent or other person having such legal custody, with the written permission of such parent or other person. Families with children status also applies to any person who is pregnant or is in the process of securing legal custody of any individual who has not attained the age of eighteen years.

((K)) L. "Federally-recognized tribe" means an entity listed on the Department of the Interior's list under the Federally Recognized Indian Tribe List Act of 1994, which the Secretary currently acknowledges as an Indian tribe and with which the United States maintains a government-to-government relationship.

((L)) M. "Gender Identity" means having or being perceived as having a gender identity, self-image, appearance, behavior, or expression, whether or not that gender identity, self-image, appearance, behavior, or expression is different from that traditionally associated with the sex assigned to that person at birth.

((M)) N. "Housing choice or other subsidy program((or alternative source of income))" means, without limitation: (i) any short or long term federal, state or local government, private nonprofit, or other assistance program in which a tenant's rent is paid either partially by the program (through a direct arrangement between the program and the owner or lessor of the real property), and partially by the tenant or completely by the program; or (ii) HUD-Veteran Affairs Supportive Housing (VASH) vouchers, Housing and Essential Needs (HEN) funds, and short-term rental assistance provided by Rapid Rehousing subsidies.

O. "Housing status" means the status of having or not having a fixed or regular residence, including, but not limited to, the status of being homeless or unhoused, living on the streets, living in an automobile or in a shelter or a temporary residence.

((N)) P. "Impairment" includes, without limitation, any:

1. physiological disorder, or condition, cosmetic disfigurement, or anatomical loss affecting one or more of the following body systems: Neurological, musculoskeletal, special sense organs, respiratory, including speech organs, cardiovascular, reproductive, digestive, genitor-urinary, hemic and lymphatic, skin and endocrine; or
2. mental, developmental, traumatic, or psychological disorder, including but not limited to cognitive limitation, organic brain syndrome, emotional or mental illness, and specific learning disabilities.

((Q)) Q. "Income" means lawful, verifiable income derived from all sources, including without limitation wages, salaries or other compensation for employment; Social Security benefits; supplemental security income; unemployment benefits; retirement programs; child support; payments from the Aged, Blind or Disabled Cash Assistance Program; Refugee Cash Assistance; any federal, state, local government, private, or nonprofit-administered benefit program, including without limitation payments from any housing choice or other subsidy program as defined in this chapter; financial aid for college students; and per capita payments or distributions received from a federally-recognized tribe.

((P)) R. "Labor organization" means an organization which is constituted for the purpose, in whole or in part, of collective bargaining or for dealing with an employer concerning grievances, terms or conditions of employment, or for other mutual aid or protection in connection with an employer.

((Q)) S. "Marital status" means the status of being married, single, separated, divorced or widowed.

((R)) T. "National origin" includes ancestry.

((S)) U. "Operational protocols" means the procedures governing how and when surveillance equipment may be used and by whom and includes, at a minimum, the information required in SMC 18.04.010.

((T)) V. "Person" includes:

1. A natural individual, partnership, association, organization, corporation, cooperative, legal representative, trustee and receiver, and any group of persons acting in concert;
2. an owner, lessee, proprietor, manager, agent or employee, of a person, whether consisting of one or more natural persons;
3. entities under common ownership; and
4. any political or civil subdivisions of the City and any agency or instrumentality of the City or of any political or civil subdivision thereof.

This definition does not include the federal government or any federally-recognized tribe.

~~((U))~~ W. "Place of public resort, accommodation, assemblage or amusement" includes, but is not limited to, any place, licensed or unlicensed, kept for gain, hire or reward, or where charges are made for admission, service, occupancy, or use of any property or facilities, whether conducted for the entertainment, housing, or lodging of transient guests, or for the benefit, use, or accommodation of those seeking health, recreation, or rest, or for the burial or other disposition of human remains, or for the sale of goods, merchandise, services, or personal property, or for the rendering of personal services, or for public conveyance or transportation on land, water or in the air, including the stations and terminals thereof and the garaging of vehicles, or where food or beverages of any kind are sold for consumption on the premises, or where public amusement, entertainment, sports, or recreation of any kind is offered with or without charge, or where medical service or care is made available, or where the public gathers, congregates, or assembles for amusement, recreation, or public purposes, or public halls, public elevators, and public washrooms of buildings and structures occupied by two or more tenants, or by the owner and one or more tenants, or any public library or educational institution, or schools of special instruction, or nursery schools, or day care centers or children's camps, provided that nothing contained in this definition shall be construed to include or apply to any institute, bona fide club, or place of accommodation, which is by its nature distinctly private, including fraternal organizations, though where public use is permitted that use shall be covered by this section; nor shall anything contained in this definition apply to any educational facility, columbarium, crematory, mausoleum, or cemetery operated or maintained by a bona fide religious or sectarian institution.

~~((V))~~ X. "Profiling" means actions of the Spokane Police Department, its members, or officers commissioned by the Spokane Police Department to rely on actual or perceived race, religion, national origin, color, creed, age, citizenship status, immigration status, refugee status, gender, sexual orientation, gender identity, disability, socio-economic status, housing status, or membership in any protected class under federal, state or local law as the determinative factor in initiating law enforcement action against an individual, rather than an individual's behavior or other information or circumstances that links a person or persons to suspected unlawful activity.

~~((W))~~ Y. "Refugee status" means the status of a person who, under the provisions of 8 USC 1101(a)(42), is outside a country of that person's nationality or, in the case of a person having no nationality, is outside any country in which that person last habitually resided, and who is unable or unwilling to return to, and is unable or unwilling to avail himself or herself of the protection of, that country because of persecution or a well-founded fear of persecution on account of race, religion, nationality, membership in a particular social group, or political opinion.

~~((X))~~ Z. "Service animal" means an animal that is trained for the purposes of assisting or accommodating a person with a disability.

((Y)) AA. "Sex" means gender.

((Z)) BB. "Sexual orientation" means heterosexuality, homosexuality, bisexuality and gender expression or identity. As used in this definition, "gender expression or identity" means having or being perceived as having a gender identity, self-image, appearance, behavior, or expression, whether or not that gender identity, self-image, appearance, behavior, or expression is different from that traditionally associated with the sex assigned to that person at birth.

((AA)) CC. "Surveillance equipment" means equipment capable of capturing or recording data, including images, videos, photographs or audio operated by or at the direction of a City department that may deliberately or inadvertently capture activities of individuals on public or private property, regardless of whether "masking" or other technology might be used to obscure or prevent the equipment from capturing certain views. "Surveillance equipment" includes drones or unmanned aircraft and any attached equipment used to collect data. "Surveillance equipment" does not include the following equipment which are in use by the City of Spokane as of March 1, 2017:

1. handheld or body-worn devices (e.g., "bodycams") used by law enforcement;
2. cameras installed in or on a police vehicle (e.g., "dashcams");
3. cameras installed in or on any City-owned vehicle, including without limitation fire trucks, emergency vehicles, utility vehicles and street maintenance vehicles, which are intended to ensure the safe operation of the vehicle;
4. cameras installed along a public right-of-way to record traffic patterns and/or traffic violations;
5. cameras intended to record activity inside or at the entrances to City buildings for security purposes; or
6. cameras installed to monitor and protect the physical integrity of City infrastructure, including without limitation fire stations and utility service facilities.

Section 4. That section 18.01.050 of the Spokane Municipal Code is amended to read as follows:

Section 18.01.050 Administration

A. Initiation.

An individual claiming to be aggrieved by a practice prohibited by SMC 18.01.040, chapter 18.02 SMC, ((e)) chapter 18.03 SMC, or SMC 18.05.040 may, within the time limit of SMC 18.01.070, file a complaint with the commission on forms made available for the purpose by commission staff.

B. Complaint.

A complaint filed by a person claiming to be aggrieved by a practice prohibited by SMC 18.01.040, chapter 18.02 SMC, ~~((or))~~ chapter 18.03 SMC, or SMC 18.05.040 shall be immediately forwarded by the commission for review by the City or an agency or organization with which the City maintains a contractual relationship for the purpose of reviewing such complaints (referred to in this section as the “reviewing agency”), to determine whether the allegations stated on the face of the complaint, if true, would be a prohibited practice as stated in SMC 18.01.040, chapter 18.02 SMC, ~~((or))~~ chapter 18.03 SMC, or SMC 18.05.040. Complaints shall be processed as follows:

1. The reviewing agency shall review the factual allegations of the complaint, interview the complainant, and take a statement from the complainant.
2. The reviewing agency then interviews the person accused of discrimination and documents that interview in a writing.
3. The reviewing agency shall also, if applicable, interview all participants and witnesses having relevant information regarding the allegation of discrimination, and document those interviews in writing.
4. If, as the result of the interviews described in subsections 1-3 of this paragraph B, the reviewing agency determines that the complaint states a violation of this chapter, the reviewing agency shall communicate that determination in writing to the complainant and the city attorney’s office, with a copy to the commission.
5. If the reviewing agency determines that the complaint does not state a violation of SMC 18.01.040, chapter 18.02 SMC, ~~((or))~~ chapter 18.03 SMC, or SMC 18.05.040, the complaint shall be dismissed immediately.
6. Complaints that claim a violation of state or federal law shall be referred to the appropriate state or federal agency.
7. Complaints that claim a violation of a prohibited practice established only in this Title 18 shall be referred to a Washington State Dispute Resolution Center established under chapter 7.75, RCW, or by a mediator agreed upon by all parties, within thirty days of the filing of the complaint. Mediation sessions are not open to the public. If the mediation resolves the complaint, the mediator will notify the City of the resolution and the complaint file will be closed.
8. Complaints that are not resolved through mediation shall be submitted to the City Prosecutor for a determination as to the filing of a civil infraction pursuant to chapter 1.05 SMC.

C. Administrative appeal.

Any person whose complaint has been dismissed pursuant to SMC 18.01.050 B(5) may appeal the dismissal to the hearing examiner, who shall review the complaint and the decision to dismiss

the complaint under an abuse of discretion standard of review. The hearing examiner may affirm the dismissal, reverse the dismissal, or remand the complaint to be processed as set forth in SMC 18.01.050(B).

D. Judicial review.

Any person who is aggrieved by the decision of the hearing examiner on administrative appeal under this section may institute an action for judicial review in the Superior Court pursuant to RCW 49.60.330.

E. The commission and its staff shall prioritize its resources to focus on resolving complaints which are not within the jurisdiction of government or non-profit agencies other than the commission.

~~((F. The City shall not take any enforcement action based on discrimination due to the use of "housing choice or other subsidy program or alternative source of income" as defined in this Title 18 before September 1, 2017. The City Council shall name an ad hoc stakeholder group to make recommendations to the City Council for amendments to Chapter 18.03 SMC, concerning the use of housing choice or other subsidy programs or alternative sources of income.))~~

Section 5. That section 18.02.010 of the Spokane Municipal Code is amended to read as follows:

Section 18.02.010 Employment

- A. No person shall discriminate by refusing to hire, employ or promote, by barring or discharging from employment, in compensation or terms, conditions or privileges of employment, unless discrimination results from a bona fide occupational requirement reasonably necessary to the normal operation of the employer's business.
- B. No person shall discriminate by printing or circulating, or by causing to be printed or circulated, any statement, advertisement or publication, or by using any employment application form, or by making an inquiry in connection with prospective employment which expresses, directly or indirectly, any discriminatory limitation or specification, unless such limitation or specification is based upon a bona fide occupational qualification reasonably necessary to the normal operation of the employer's business, or unless otherwise provided by state or federal law.
- C. No person shall discriminate by classifying or referring for employment, or by failing or refusing to refer for employment, or otherwise, unless such classification or referral results from a bona fide occupational requirement reasonably necessary to the normal operation of the employer's business, or where such classification or referral is allowed under state or federal law~~((;))~~.

D. No person shall reject or disqualify an applicant for employment solely because the individual does not have a fixed or regular residence, or because the individual is homeless or unhoused, or because the individual lives on the street, in an automobile, in a shelter, or in a temporary residence, unless the individual's housing status has a bona fide and legitimate relation to the primary duties of the job and such rejection or disqualification does not otherwise violate state or federal employment laws or regulations.

Section 6. That section 18.03.010 of the Spokane Municipal Code is amended to read as follows:

Section 18.03.010 Prohibited Practices

- A. It is a violation of this chapter for any person to discriminate by:
1. refusing to sell, lease, rent or otherwise make available any offered real property;
 2. expelling a purchaser, lessee or renter from any real property;
 3. altering the price, terms, conditions or privileges relating to the sale, rental, lease or occupancy of real property, or in the furnishing of any facilities or services in connection with real property;
 4. attempting to discourage the sale, rental or lease of any real property to a purchaser, lessee or renter;
 5. publishing, circulating, issuing or displaying, or causing to be published, circulated, issued or displayed, any communication, notice, advertisement or sign of any kind relating to the sale, rental or lease of real property which indicates any preference, limitation or specification with respect thereto;
 6. assisting, inducing, compelling or coercing another person to commit an act or engage in a practice that violates this subsection;
 7. coercing, intimidating, threatening or interfering with any person in the exercise or enjoyment of, or on account of having aided or encouraged any other person in the exercise of, any right granted or protected by this subsection.
- B. No person whose business includes engaging in residential real estate related transactions may discriminate in making available or in the terms and conditions of such a transaction. "Residential real estate related transaction" means the making or purchasing of loans or providing other financial assistance for purchasing, construction, improving, repairing or maintaining a dwelling or securing residential real estate, or the selling, brokering or appraising of residential real property.
- C. No real estate licensee may accept or retain a listing of real property for sale, lease or rental with an understanding that a purchaser may be discriminated against with respect to the sale, rental or lease.

- D. No person may for profit induce or attempt to induce any other person to sell or rent any dwelling by representations regarding entry or prospective entry into the neighborhood of a person or person of a particular race, religion, creed, color, sex, national origin, marital status, familial status, housing status, domestic violence victim status, age, sexual orientation, gender identity, honorably discharged veteran or military status, refugee status, or the presence of any sensory, mental or physical disability as defined by the American with Disabilities Act and/or the Washington State Law Against Discrimination, Chapter 49.60 RCW.

Section 7. That there is enacted a new section 18.05.040 of the Spokane Municipal Code to read as follows:

Section 18.05.040 Human Rights of Individuals Experiencing Homelessness

No person's rights, privileges, or access to public services and accommodations may be denied or abridged in violation of applicable laws solely because of their housing status. Such a person shall enjoy the same rights, privileges, and responsibilities as any other resident of the City of Spokane. A person experiencing homelessness:

1. Has the right to equal treatment by all municipal agencies, without discrimination on the basis of housing status;
2. Has the right not to face discrimination while seeking or maintaining employment in the City of Spokane based on the person's housing status, lack of permanent mailing address, or having a mailing address of a shelter or social service provider unless the individual's housing status has a bona fide and legitimate relation to the primary duties of the job;
3. Has the right to be free from unreasonable searches of their person or property when seeking or receiving comprehensive support services, including shelter services; and
4. Has the right to retain control of their personal papers and other essential personal property when seeking or receiving comprehensive support services, including shelter services, subject only to the City's Encampment Policy as enforced in the interest of the safety of city employees, personal property rights and general health and welfare of public and its infrastructure.

Section 8. Severability. If any section, subsection, sentence, clause, phrase or word of this ordinance should be held to be invalid or unconstitutional by a court of competent jurisdiction, such invalidity or unconstitutionality thereof shall not affect the validity or constitutionality of any other section, subsection, sentence, clause, phrase or word of this ordinance.

Section 9. Clerical Errors. Upon approval by the city attorney, the city clerk is authorized to make necessary corrections to this ordinance, including scrivener's errors or clerical mistakes;

ORD C36549 (DILLON NAVARRETE AMENDMENT) (08-08-24)

references to other local, state, or federal laws, rules, or regulations; or numbering or referencing of ordinances or their sections and subsections.

PASSED by the City Council on _____.

Council President

Attest:

Approved as to form:

City Clerk

Assistant City Attorney

Mayor

Date

Effective Date

TRANSMITTAL OF FIRST READING ORDINANCE

DATE: July 22, 2024

TO: Eldon Brown
Engineering Services

Clerk's File No.
ORD C36550

FROM: Terri Pfister, City Clerk

RE: Vacation of portions of Thirteenth Avenue and Woodland Boulevard

Attached is a copy of Ordinance C36550 for the vacation of:

Amending Ordinance C-26051 that vacated Thirteenth Avenue and Woodland Boulevard from the southeast right of way line of I-90 to the west line of "A" Street, Evergreen Drive from the southeast right of way line of I-90 to the north line of Fourteenth Avenue and the unnamed strip of land south of Lot 12 and north of Lots 17, 18, and 19, Block 16, Woodland Heights Addition, from the west line of Evergreen Drive to the extended west line of said Lots 12 and 17, and providing for an effective date.

This ordinance was read for the first time on July 22, 2024, and will be read for the final time when the necessary conditions have been met and this transmittal, signed and dated by the Engineering Services Director, is returned to the City Clerk's Office.



City Clerk



Date

Precedent conditions have been met and Ordinance C36550 is hereby returned for Final Reading.



Principal Engineer – Developer Services

Dated: 

**Agenda Sheet for City Council:****Committee:** Urban Experience **Date:** 08/12/2024**Committee Agenda type:** Discussion**Date Rec'd**

7/9/2024

Clerk's File #

ORD C36550

Cross Ref #**Project #****Council Meeting Date:** 07/22/2024**Submitting Dept**

DEVELOPMENT SERVICES CENTER

Bid #**Contact Name/Phone**

ELDON BROWN 509-625-6305

Requisition #**Contact E-Mail**

EBROWN@SPOKANECITY.ORG

Agenda Item Type

First Reading Ordinance

Council Sponsor(s)

ZZAPPONE KKLITZKE

Agenda Item Name

AMENDING ORD C-26051 TO RELEASE AN EASEMENT

Agenda Wording

Amending Ord C-26051 to Release an Easement

Summary (Background)

On June 8, 1981 Spokane City Council passed Ordinance C-26051 that vacated various rights-of-way south of I-90. Easements for public & private utilities were reserved in that vacation ordinance. The Prose Development Project Building Permits are currently under review and the Developer is requesting that easements encumbering that property be released. The City of Spokane has received letters of support from the utility purveyors.

Lease? NO

Grant related? NO

Public Works? NO

Fiscal Impact

Approved in Current Year Budget? N/A

Total Cost

\$

Current Year Cost

\$

Subsequent Year(s) Cost

\$

Narrative**Amount****Budget Account**

Neutral

\$

#

Select

\$

#

Select

\$

#

Select

\$

#

\$

#

\$

#



Continuation of Wording, Summary, Approvals, and Distribution

Agenda Wording

Summary (Background)

Approvals

Dept Head

PALMQUIST, TAMI

Division Director

MACDONALD, STEVEN

Accounting Manager

ALBIN-MOORE, ANGELA

Legal

RICHMAN, JAMES

For the Mayor

PICCOLO, MIKE

Additional Approvals

Distribution List

Steve MacDonald smacdonald@spokanecity.org

Tami Palmquist tpalmquist@spokanecity.org

Eldon Brown ebrown@spokanecity.org

Erik Johnson edjohnson@spokanecity.org

Kim Kuchlenz kkuchlenz@spokanecity.org

Elizabeth Rivera erivera@spokanecity.org

AGENDA ITEM PROCESSING SHEET

PLEASE FILL IN AS MUCH INFORMATION AS POSSIBLE – IF YOU NEED ASSISTANCE PLEASE CONTACT THE ADMIN GROUP

City Council Meeting Date: August 12, 2024

Submitting Dept: DSC - Development Services Center Other:

Name of Staff Member Presenting to Council: Eldon Brown x6305

Agenda Type: First Reading Ordinance

Agenda Item Name: Amending Ord C-26051 to Release an Easement

Agenda Wording (250 Character Max): Amending Ord C-26051 to Release an Easement

Summary Background (500 Character Limit): On June 8, 1981 Spokane City Council passed Ordinance C-26051 that vacated various rights-of-way south of I-90. Easements for public & private utilities were reserved in that vacation ordinance. The Prose Development Project Building Permits are currently under review and the Developer is requesting that easements encumbering that property be released. The City of Spokane has received letters of support from the utility purveyors.

Grant Related? Yes No

Public Works Related? Yes No

Fiscal Impact: Neutral

If Revenue or Expense:

**** If the item is an expense, please complete & include an Expenditure Control Form with the other documents.**

Council Notifications: Urban Experience – 7/8/2024

**** City Council Sponsor:**

Any Additional Approvals Required:

Distribution List: I add the Submitter, Department Head, and Division Head to all agenda submittals.

jeliason@spokanecity.org, ebrown@spokanecity.org, mnilsson@spokanecity.org

PLEASE PROVIDE DOCUMENTS (ELECTRONIC IF AVAILABLE) THAT NEED TO BE SUBMITTED WITH THE AGENDA ITEM

Amending Ordinance C-26051



Legend
 Vacated Evergreen Dr.

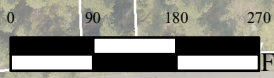

Amending Ordinance C-26051 to release the utility easement that was reserved in Ordinance C-26051 across vacated Evergreen Drive.

*THIS IS NOT A LEGAL DOCUMENT:
The information shown on this map is compiled from various sources and is subject to constant revision. Information shown on this map should not be used to determine the location of facilities in relationship to property lines, section lines, streets, etc.*



City of Spokane
Development Services Center
808 West Spokane Falls Blvd.
Spokane, WA 99201-3343
(509) 625-6300

ORDINANCE NO. C36550

An ordinance amending Ordinance C-26051 that vacated Thirteenth Avenue and Woodland Boulevard from the southeast right of way line of I-90 to the west line of "A" Street, Evergreen Drive from the southeast right of way line of I-90 to the north line of Fourteenth Avenue and the unnamed strip of land south of Lot 12 and north of Lots 17, 18, and 19, Block 16, Woodland Heights Addition, from the west line of Evergreen Drive to the extended west line of said Lots 12 and 17, and providing for an effective date.

WHEREAS, a petition for the vacation of Thirteenth Avenue and Woodland Boulevard from the southeast right of way line of I-90 to the west line of "A" Street; Evergreen Drive from the southeast right of way line of I-90 to the north line of Fourteenth Avenue and the unnamed strip of land south of Lot 12 and north of Lots 17, 18, and 19, Block 16, Woodland Heights Addition, from the west line of Evergreen Drive to the extended west line of said lots 12, and 17, has been filed with the City Clerk representing 100% of the abutting property owners, and a hearing has been held on this petition before the City Council as provided by RCW 35.79; and

WHEREAS, the City Council has found that the public use, benefit and welfare will best be served by the vacation of said public way; - NOW THEREFORE,

The City of Spokane does ordain:

Section 1. That Thirteenth Avenue and Woodland Boulevard from the southeast right of way line of I-90 to the west line of "A" Street; Evergreen Drive from the southeast right of way line of I-90 to the north line of Fourteenth Avenue and the unnamed strip of land south of Lot 12 and north of Lots 17, 18, and 19, Block 16, Woodland Heights Addition, from the west line of Evergreen Drive to the extended west line of said lots 12, and 17 are hereby vacated.

Section 2. That the City reserves and retains easement for utilities over Woodland Boulevard ~~and Evergreen Drive~~ as herein vacated and no buildings or structures shall be erected thereon without written permission of the Public Works Director.

Section 3. Passage of this ordinance shall be subject to the approval of the City Zoning Board of the special permit application for the Planned Unit Development being

proposed for this area.

Section 4. This ordinance shall take effect and be in force thirty (30) days from and after its passage.

Passed the City Council _____

Council President

Attest: _____
City Clerk

Approved as to Form:

Assistant City Attorney

Mayor

Date: _____

Effective Date: _____



Agenda Sheet for City Council:

Committee: Finance & Administration **Date:** 07/22/2024

Committee Agenda type: Discussion

Date Rec'd

7/3/2024

Clerk's File #

ORD C36543

Cross Ref #

Project #

Council Meeting Date: 07/15/2024

Submitting Dept

CITY COUNCIL

Bid #

Contact Name/Phone

CM CATHCART 6257

Requisition #

Contact E-Mail

MCATHCART@SPOKANECITY.ORG

Agenda Item Type

First Reading Ordinance

Council Sponsor(s)

MCATHCART BWILKERSON

Agenda Item Name

0320 - ORDINANCE ESTABLISHING CITY HOLIDAYS

Agenda Wording

AN ORDINANCE designating the Lunar New Year, Martin Luther King Jr. Day and Juneteenth as official City of Spokane holidays, making technical corrections to Chapter 03.03 of the Spokane Municipal Code, amending Section 03.03.010 of the Spokane Municipi

Summary (Background)

Current city holidays are set forth in SMC 03.03.010, and include seven holidays, including New Year's, Memorial Day, July 4, Labor Day, Thanksgiving and the Friday after, and Christmas Day. Other employee holidays are governed in large part by collective bargaining agreements. The point of this ordinance is to give official recognition in the form of an official city holidays that already receive state recognition for individuals and events of cultural significance to the Spokane community.

Lease? NO

Grant related? NO

Public Works? NO

Fiscal Impact

Approved in Current Year Budget? NO

Total Cost \$ unknown

Current Year Cost \$ unknown

Subsequent Year(s) Cost \$

Narrative

Fiscal impact of adding these holidays is unclear at this time. Because employee holidays are governed by this SMC and collective bargaining agreements, the actual impact on City operations may vary.

Amount

Budget Account

Expense \$ unknown

tbd

Select \$

#

Select \$

#

Select \$

#

\$

#

\$

#

Committee Briefing Paper

Finance & Administration Committee

Committee Date	June 24, 2024
Submitting Department	City Council
Contact Name	Chris Wright
Contact Email & Phone	cwright@spokanecity.org / 625-6210
Council Sponsor(s)	Wilkerson Cathcart
Select Agenda Item Type	<input type="checkbox"/> Consent <input checked="" type="checkbox"/> Discussion Time Requested: 10
Agenda Item Name	Ordinance Establishing City Holidays
Proposed Council Action	<input checked="" type="checkbox"/> Approval to proceed to Legislative Agenda <input type="checkbox"/> Information Only
Summary (Background) *use the Fiscal Impact box below for relevant financial information	<p>Current city holidays are set forth in SMC 03.03.010, and include seven holidays, including New Year’s, Memorial Day, July 4, Labor Day, Thanksgiving and the Friday after, and Christmas Day. Other employee holidays are governed in large part by collective bargaining agreements.</p> <p>This ordinance would amend SMC 03.03.010 by adding Martin Luther King Day (the third Monday of February), Lunar New Year (first day of first lunar month), and Juneteenth (June 19) as official city holidays commencing in 2025.</p> <p>Currently MLK Day and Juneteenth are official holidays of the State of Washington.</p>

Fiscal Impact

Approved in current year budget? Yes No N/A

Total Cost: [Click or tap here to enter text.](#)

 Current year cost: None known

 Subsequent year(s) cost: Unknown

Narrative: Fiscal impact of adding these holidays is unclear at this time. Because employee holidays are governed by this SMC and collective bargaining agreements, the actual impact on City operations may vary depending whether the ordinance change actually results in additional employee holidays for specific bargaining units. This analysis is ongoing.

Funding Source One-time Recurring N/A

Specify funding source: Select Funding Source*

Is this funding source sustainable for future years, months, etc? **Unknown at this time**

Expense Occurrence One-time Recurring N/A

Other budget impacts: (revenue generating, match requirements, etc.) **Not known at this time**

Operations Impacts (If N/A, please give a brief description as to why)

- What impacts would the proposal have on historically excluded communities?

The point of this ordinance is to give official recognition – in the form of an official city holidays that already receive state recognition – for individuals and events of cultural significance to Spokane communities of color, and which are celebrated locally at this time.

- How will data be collected, analyzed, and reported concerning the effect of the program/policy by racial, ethnic, gender identity, national origin, income level, disability, sexual orientation, or other existing disparities?

Not applicable.

- How will data be collected regarding the effectiveness of this program, policy, or product to ensure it is the right solution?

Not applicable

- Describe how this proposal aligns with current City Policies, including the Comprehensive Plan, Sustainability Action Plan, Capital Improvement Program, Neighborhood Master Plans, Council Resolutions, and others?

Under SMC 01.03.030 the official motto of the City of Spokane is “In Spokane We all Belong.” Adding these holidays is consistent with this motto and gives further municipal recognition to icons and events important to Spokane’s communities of color.

Council Subcommittee Review

- Please provide a summary of council subcommittee review. If not reviewed by a council subcommittee, please explain why not.

There has not been subcommittee review. It is possible the ordinance will receive review of the Equity Subcommittee at a future date.

ORDINANCE NO. C-36543

AN ORDINANCE designating the Lunar New Year, Martin Luther King Jr. Day and Juneteenth as official City of Spokane holidays, making technical corrections to Chapter 03.03 of the Spokane Municipal Code, amending Section 03.03.010 of the Spokane Municipal Code, making technical corrections to Section 03.03.050 of the Spokane Municipal Code and adding a new section 03.03.070 to the Spokane Municipal Code.

WHEREAS, recognizing the cultural diversity of our community enriches the social fabric and promotes a comprehensive understanding and appreciation among its members; and

WHEREAS, Martin Luther King Jr. was a pivotal figure in the American civil rights movement and known for compassionate and insightful statements on civil rights, racial equality, and non-violence as a form of civil protest; and

WHEREAS, “Martin Luther King Jr. Day” was officially adopted by the United States Congress in 1983 and first observed at the federal level on January 20, 1986; and is a day of service and celebrates the life, legacy, and achievements of the civil rights leader; and

WHEREAS, Lunar New Year, a significant celebration for many Asian communities, marks the beginning of the lunar calendar and is a time of festivity and family reunions, reflecting the rich cultural heritage and contributions of these communities to our society; and

WHEREAS, since its celebrated return in 2022 after an 87-year hiatus, the Lunar New Year festival has rapidly grown in popularity in Spokane, drawing significant participation from the community and demonstrating the vibrant cultural heritage and traditions of the Asian communities within the city; and

WHEREAS, Juneteenth, commemorating the end of slavery in the United States, serves as a historical milestone that promotes reflection, education, and celebration of freedom and justice for all citizens; and

WHEREAS, recognizing the significance of Juneteenth as a pivotal moment in American history, the United States Congress has officially designated June 19th as a federal holiday, further affirming its national importance and acknowledging the

ongoing pursuit of equality and justice for all; and

WHEREAS, Juneteenth is the oldest nationally/internationally celebrated commemoration of the ending of slavery in the United States;

WHEREAS, both Martin Luther King Jr. Day and Juneteenth are recognized as official state holidays by the State of Washington; and

WHEREAS, the City Council of the City of Spokane wish to formally establish Martin Luther King Jr. Day, Lunar New Year, and Juneteenth as official holidays of the City of Spokane,

NOW THEREFORE, the City of Spokane does ordain:

Section 1. Section 03.03.010 of the Spokane Municipal Code is amended as follows:

Section 03.03.010 Legal Holidays Specified

Commencing January 1, 2025, ((The)) the following days each year are legal holidays during which all offices, including municipal court, are closed to the transaction of business, except ((the)) essential ((departments)) operations:

- A. The first day of January, commonly called “New Year’s Day.”
- B. The day corresponding to the first day of the first lunar month, commonly known as “Lunar New Year”, which may vary each year.
- C. The third Monday of February, commonly called “Martin Luther King. Jr. Day.”
- ~~((B))~~ D. The last Monday of May, commonly known as “Memorial Day.”
- E. The nineteenth of June, commonly called “Juneteenth.”
- ~~((G))~~ F. The fourth day of July, commonly known as “Independence Day,”.
- ~~((D))~~ G. The first Monday in September, commonly known as “Labor Day”.
- ~~((E))~~ H. The fourth Thursday of November, commonly known as “Thanksgiving Day”.
- ~~((F))~~ I. The Friday following Thanksgiving Day; and

((G)) J. The twenty-fifth day of December, commonly known as “Christmas Day”.

Section 2. Section 03.03.050 of the Spokane Municipal Code is amended as follows:

Section 03.03.050 Non-uniformed Employees

For non-uniformed employees on a work schedule other than Monday through Friday, the following holiday policy applies:

- A. When a holiday observed by the City falls on an employee’s first day of rest, the preceding day is recognized as ~~((his))~~ that employee’s holiday.
- B. When a holiday observed by the City falls on an employee’s second day of rest, the following day is recognized as ~~((his))~~ that employee’s holiday.
- C. If an employee is required to work on ~~((his))~~ a holiday as outlined in subsections (A) and (B) of this section due to essential operations, ~~((he))~~ that employee is compensated at one and one-half times ~~((his))~~ the employee’s hourly rate ~~((in addition to straight-time pay))~~ or as otherwise set forth pursuant to that employee’s collective bargaining agreement.

Section 3. There is added to Chapter 03.03 of the Spokane Municipal Code a new Section 03.03.070 to read as follows:

Section 03.03.070 Essential Operations

For purposes of this Chapter 03.03, the term “essential operations” shall mean:

- A. The Police Division;
- B. The Fire Division; and
- C. Any city department, division, or function designated as an “essential operation” by the Mayor.

Section 4. Severability. If any section, subsection, sentence, clause, phrase or word of this ordinance should be held to be invalid or unconstitutional by a court of competent jurisdiction, such invalidity or unconstitutionality thereof shall not affect the

validity or constitutionality of any other section, subsection, sentence, clause, phrase or word of this ordinance.

Section 5. Clerical Errors. Upon approval by the city attorney, the city clerk is authorized to make necessary corrections to this ordinance, including scrivener’s errors or clerical mistakes; references to other local, state, or federal laws, rules, or regulations; or numbering or referencing of ordinances or their sections and subsections.

PASSED by the City Council on _____, 2024.

Council President

Attest

Approved as to Form

City Clerk

City Attorney

Mayor

Date

Effective Date



Agenda Sheet for City Council:

Committee: Finance & Administration **Date:** 07/22/2024

Committee Agenda type: Discussion

Date Rec'd

7/3/2024

Clerk's File #

ORD C36544

Cross Ref #

Project #

Council Meeting Date: 07/15/2024

Submitting Dept

CITY COUNCIL

Bid #

Contact Name/Phone

CM CATHCART 6257

Requisition #

Contact E-Mail

MCATHCART@SPOKANECITY.ORG

Agenda Item Type

First Reading Ordinance

Council Sponsor(s)

MCATHCART JBINGLE

Agenda Item Name

0320 - PROHIBITION OF CAMPING NEAR SUPPORT FACILITIES

Agenda Wording

AN ORDINANCE prohibiting illegal encampments near facilities offering comprehensive support services and amending Title 12, Chapter 12.02, of the Spokane Municipal Code.

Summary (Background)

The citizens of Spokane in 2023 voted to amend the Spokane Municipal Code and expand the prohibition on illegal camping to those areas within one thousand feet of schools, day cares, and parks. Homeless and unhoused individuals will often camp at or near addiction treatment facilities, behavioral health facilities, or other support facilities. The updated language expands the prohibition against unlawful camping to include areas that provide essential recovery services for the Spokane community.

Lease? NO

Grant related? NO

Public Works? NO

Fiscal Impact

Approved in Current Year Budget? N/A

Total Cost

\$

Current Year Cost

\$

Subsequent Year(s) Cost

\$

Narrative

Amount

Budget Account

Neutral

\$

#

Select

\$

#

Select

\$

#

Select

\$

#

\$

#

\$

#



Continuation of Wording, Summary, Approvals, and Distribution

Agenda Wording

Summary (Background)

Approvals		Additional Approvals	
<u>Dept Head</u>			
<u>Division Director</u>			
<u>Accounting Manager</u>			
<u>Legal</u>			
<u>For the Mayor</u>			

Distribution List

mcart@spokanecity.org

sblackwell@spokanecity.org

Committee Agenda Sheet

Finance & Administration Committee

Committee Date	June 3, 2024
Submitting Department	City Council
Contact Name	Shae Blackwell
Contact Email & Phone	sblackwell@spokanecity.org
Council Sponsor(s)	CM Cathcart
Select Agenda Item Type	<input type="checkbox"/> Consent <input checked="" type="checkbox"/> Discussion Time Requested: 10
Agenda Item Name	Camping Prohibition Near Recovery and Supportive Services
Proposed Council Action	<input type="checkbox"/> Approval to proceed to Legislative Agenda <input type="checkbox"/> Information Only
Summary (Background) *use the Fiscal Impact box below for relevant financial information	An ordinance prohibiting illegal encampments near facilities offering comprehensive support services and amending Title 12, Chapter 12.02, of the Spokane Municipal Code. The updated language expands the prohibition against unlawful camping to include areas that provide essential recovery services for the Spokane community.
<p>Fiscal Impact</p> <p>Approved in current year budget? <input type="checkbox"/> Yes <input type="checkbox"/> No <input checked="" type="checkbox"/> N/A</p> <p>Total Cost: Click or tap here to enter text.</p> <p> Current year cost:</p> <p> Subsequent year(s) cost:</p> <p>Narrative: Please provide financial due diligence review, as applicable, such as number and type of positions, grant match requirements, summary type details (personnel, maintenance and supplies, capital, revenue), impact on rates, fees, or future shared revenue</p> <p>Funding Source <input type="checkbox"/> One-time <input type="checkbox"/> Recurring <input checked="" type="checkbox"/> N/A</p> <p>Specify funding source: Select Funding Source*</p> <p>Is this funding source sustainable for future years, months, etc? Click or tap here to enter text.</p> <p>Expense Occurrence <input type="checkbox"/> One-time <input type="checkbox"/> Recurring <input checked="" type="checkbox"/> N/A</p> <p>Other budget impacts: (revenue generating, match requirements, etc.)</p>	
<p>Operations Impacts (If N/A, please give a brief description as to why)</p> <ul style="list-style-type: none"> • What impacts would the proposal have on historically excluded communities? 	

- How will data be collected, analyzed, and reported concerning the effect of the program/policy by racial, ethnic, gender identity, national origin, income level, disability, sexual orientation, or other existing disparities?
- How will data be collected regarding the effectiveness of this program, policy, or product to ensure it is the right solution?
- Describe how this proposal aligns with current City Policies, including the Comprehensive Plan, Sustainability Action Plan, Capital Improvement Program, Neighborhood Master Plans, Council Resolutions, and others?

Council Subcommittee Review

- Please provide a summary of council subcommittee review. If not reviewed by a council subcommittee, please explain why not.

ORDINANCE NO. C36544

AN ORDINANCE prohibiting illegal encampments near facilities offering comprehensive support services and amending Title 12, Chapter 12.02, of the Spokane Municipal Code.

WHEREAS, the Spokane Municipal Code prohibits illegal camping within the city limits, including riverbanks, natural areas, public parks and on other public property ; and

WHEREAS, the citizens of Spokane in 2023 voted to amend the Spokane Municipal Code and expand the prohibition on illegal camping to those areas within one thousand feet of schools, day cares, and parks; and

WHEREAS, homeless and unhoused individuals will often camp at or near addiction treatment facilities, behavioral health facilities, or other support facilities, posing a threat to individuals seeking and receiving services at those facilities; and

WHEREAS, it is the desire of the City Council to expand the prohibition against unlawful camping to include areas that provide essential recovery services for the Spokane community,

NOW, THEREFORE, the City of Spokane does ordain:

Section 1. Section 12.02.1002 of the Spokane Municipal Code is amended to read as follows:

The following definitions are applicable in this chapter unless the context otherwise requires:

- A. "Camp" means to pitch, erect or occupy camp facilities, or to use camp paraphernalia or both, for the purpose of, or in such a way as will facilitate, outdoor sheltering for living accommodation purposes or for remaining outdoors overnight, or using a camper, recreational vehicle, trailer, or other vehicle for living accommodation purposes or for the purpose of remaining overnight.
- B. "Camp facilities" include, but are not limited to, tents, huts, temporary shelters, campers, recreational vehicles, or trailers.
- C. "Camp paraphernalia" includes but is not limited to tarpaulins, cots, beds, sleeping bags, hammocks or cooking facilities and similar equipment.
- D. "Park or park facility" means any real property, building, structure, equipment, sign, shelter, swimming pool, vegetation, playground, or other physical property owned or controlled by the City for park purposes. Park or park facility includes all associated areas, including but not limited to parking lots for parks and pools. All park property, whether developed or undeveloped, including adjacent buffer lands,

conservation lands and natural areas, shall be considered to be a “park facility” for purposes of this chapter.

- E. “Public property” shall mean any City-owned property, including but not limited to, parks or park facilities, riverbanks, waterways, conservation areas, natural areas, rights of way, easements, buildings, bridges, or other land or physical structures owned or managed by the City.
- F. “Public Tree” is a tree on City-owned property or on the public right-of-way abutting City-owned property. A public tree may also be a street tree. “City-owned property” does not refer to the right-of-way.
- G. “Right-of-way” means any street, avenue, boulevard, highway, sidewalk, alley, passageway, or other thoroughfare, whether abutting public or private property, used for vehicular or pedestrian travel.
- H. “Street tree” means any tree or shrub located within the public right-of-way.
- I. “Comprehensive Support Services” means services encompassing addiction recovery services, resource distribution centers, congregate shelters, transitional or non-permanent housing. Such services include, but are not limited to, behavioral health services providers as defined in RCW 71.05.020.

Section 2. Section 12.02.1010 of the Spokane Municipal Code is amended as follows:

A. Prohibition

- 1. No person may camp in or upon any public property including, but not limited to, on conservation lands and natural areas abutting the Spokane River, Latah Creek and their tributaries, unless specifically authorized by declaration of the Mayor in emergency circumstances.
- 2. At all times, regardless of the availability of shelter, it is unlawful to camp where such activity poses:
 - a. a substantial danger to any person,
 - b. an immediate threat and/or an unreasonable risk of harm to public health or safety, or
 - c. a disruption to vital government services.

In such circumstances, the encampment shall be subject to expedited removal pursuant to SMC 12.02.1011.

3. At all times, regardless of the availability of shelter space or beds, it is unlawful to camp or store personal property, including camp facilities and camp paraphernalia, or to have unauthorized encampments, at any time in the following locations:
 - a. Underneath or within 50 feet of any railroad viaduct (~~(located within the Spokane Police Department's Downtown Precinct boundary as shown out in Exhibit A; and)~~), or
 - b. Within (~~three blocks~~) one thousand (1000) feet of any (~~congregate shelter~~) facility providing comprehensive support services, provided that signs are posted prohibiting camping that are clearly visible to pedestrians; or
 - c. In public within one thousand (1,000) feet of the perimeter of the grounds of a park (SMC Section 12.06A.030(B&D)), a day care center or child care facility (RCW 35.63.170(3-4)), or a public or private school (RCW 28A.150.010 and RCW 28A.195.010).

B. Penalty

A violation of this section is a misdemeanor. Unless otherwise subject to custodial arrest on a warrant or probable cause for another crime, individuals subject to enforcement under this section shall be cited and released rather than being booked into jail. With the exception of those who do not meet the criteria for acceptance into community court, individuals subject to enforcement under this chapter shall be referred to community court by officer citation.

C. Enforcement

1. Law enforcement officers shall not issue a criminal citation to enforce unauthorized camping in violation of section 12.02.1010 (A)(1) when an individual is on public property at a time when there is no available overnight shelter. Nothing in this section shall be construed to prevent the enforcement of section 12.02.1003 at all times, regardless of the availability of shelter, when a person is causing harm to the Spokane River or Latah Creek or to the banks and natural areas that buffer these waterways; nor shall this section be construed to prevent the expedited removal of an encampment on any public property pursuant to section 12.02.1012 (C).
 - a. Prior to issuing a citation to a homeless person who is sleeping, lying, sitting, or camping outdoors, the police officer must first confirm that a 24/7 low-barrier shelter had available space during the previous twenty-four hours that could have been utilized by that individual.

- b. Confirmation of overnight shelter availability may come from data provided through a City-approved data system or through direct contact with regional low-barrier shelters, and shall consist of the following:
 - i. whether a shelter has available space for sleeping,
 - ii. the number of available spaces, and
 - iii. the guests each shelter will accept (i.e. men, women, families with children, etc.).

2. Sections 12.02.1010 (A)(2) and (A)(3) are enforceable at all times regardless of shelter availability((τ)).

Section 3. Rule-Making. The Department of Community and Economic Development is authorized to promulgate a public rule consistent with, and necessary to implement and enforce, the provisions of Sections 12.02.1000 through 12.02.1012 of the Spokane Municipal Code. Any public rule promulgated under this chapter shall be submitted to the city council for approval by resolution no later than the date of its adoption or within 60 days of the effective date of this ordinance, whichever is later.

Section 4. Severability. If any section, subsection, sentence, clause, phrase or word of this ordinance should be held to be invalid or unconstitutional by a court of competent jurisdiction, such invalidity or unconstitutionality thereof shall not affect the validity or constitutionality of any other section, subsection, sentence, clause, phrase or word of this ordinance.

Section 5. Clerical Errors. Upon approval by the city attorney, the city clerk is authorized to make necessary corrections to this ordinance, including scrivener’s errors or clerical mistakes; references to other local, state, or federal laws, rules, or regulations; or numbering or referencing of ordinances or their sections and subsections.

PASSED by the City Council on June ____, 2024.

Council President

Attest:

Approved as to form:

City Clerk

City Attorney

Mayor

Date

Effective Date



Agenda Sheet for City Council:

Committee: PIES **Date:** 07/15/2024

Committee Agenda type: Discussion

Date Rec'd 7/15/2024

Clerk's File # ORD C36557

Cross Ref #

Project #

Council Meeting Date: 08/12/2024

Submitting Dept MAYOR

Bid #

Contact Name/Phone ADAM 6779, 6776

Requisition #

Contact E-Mail AMCDANIEL@SPOKANECITY.ORG

Agenda Item Type First Reading Ordinance

Council Sponsor(s) BWILKERSON KKLITZKE

Agenda Item Name ESTABLISHING THE CLIMATE RESILIENCE AND SUSTAINABILITY BOARD

Agenda Wording

This ordinance will create the Climate Resilience and Sustainability Board (CRSB). It repeals the Sustainability Action Committee (SMC 04.36) that was not empaneled by the previous two administrations.

Summary (Background)

The Climate Resilience and Sustainability Board is made up of up to 15 members. The role of the Climate Resilience and Sustainability Board is to: serve as the Climate Policy Advisory Committee for the Climate portion of the Comprehensive Plan and provide recommendations to the Mayor and Council on policies and funding opportunities that advance the goals and priorities of the Sustainability Action Plan and Climate Element of the Comprehensive Plan.

Lease? NO Grant related? NO Public Works? NO

Fiscal Impact

Approved in Current Year Budget? N/A

Total Cost \$

Current Year Cost \$

Subsequent Year(s) Cost \$

Narrative

Amount

Budget Account

Select \$ #

Select \$ #

Select \$ #

Select \$ #

\$ #

\$ #



Continuation of Wording, Summary, Approvals, and Distribution

Agenda Wording

Summary (Background)

Approvals

Dept Head

JONES, GARRETT

Division Director

Accounting Manager

BUSTOS, KIM

Legal

SCHOEDEL, ELIZABETH

For the Mayor

PICCOLO, MIKE

Additional Approvals

Distribution List

amcdaniel@spokanecity.org

kthomas@spokanecity.org

Committee Agenda Sheet

Public Infrastructure, Environment & Sustainability Committee

Committee Date	7/15/2024
Submitting Department	Mayor's Office
Contact Name	Adam McDaniel Kelly Thomas
Contact Email & Phone	amcdaniel@spokanecity.org
Council Sponsor(s)	Please enter the name of the Council Sponsor(s)
Select Agenda Item Type	<input type="checkbox"/> Consent <input checked="" type="checkbox"/> Discussion Time Requested: 5 minutes
Agenda Item Name	Establishing the Climate Resilience and Sustainability Board
Proposed Council Action	<input checked="" type="checkbox"/> Approval to proceed to Legislative Agenda <input type="checkbox"/> Information Only
Summary (Background) *use the Fiscal Impact box below for relevant financial information	<p>This ordinance will create the Climate Resilience and Sustainability Board (CRSB). It repeals the Sustainability Action Committee (SMC 04.36) that was not empaneled by the previous two administrations.</p> <p>The Climate Resilience and Sustainability Board is made up of up to 15 members with broad representation including members from communities facing disproportionate environmental disparities, individuals with expertise in climate planning or emergency management, entrepreneurs with experience implementing sustainability initiatives, and students from local high schools and universities.</p> <p>The role of the Climate Resilience and Sustainability Board is to: serve as the Climate Policy Advisory Committee for the Climate portion of the Comprehensive Plan and provide recommendations to the Mayor and Council on policies and funding opportunities that advance the goals and priorities of the Sustainability Action Plan and Climate Element of the Comprehensive Plan.</p> <p>The Board's work plan is adopted annually by the City Council.</p>
<p>Fiscal Impact</p> <p>Approved in current year budget? <input type="checkbox"/> Yes <input type="checkbox"/> No <input checked="" type="checkbox"/> N/A</p> <p>Total Cost: Click or tap here to enter text.</p> <p>Current year cost:</p> <p>Subsequent year(s) cost:</p> <p>Narrative: Please provide financial due diligence review, as applicable, such as number and type of positions, grant match requirements, summary type details (personnel, maintenance and supplies, capital, revenue), impact on rates, fees, or future shared revenue</p> <p>Funding Source <input type="checkbox"/> One-time <input type="checkbox"/> Recurring <input checked="" type="checkbox"/> N/A</p> <p>Specify funding source: Reallocation</p> <p>Is this funding source sustainable for future years, months, etc?</p> <p>Expense Occurrence <input type="checkbox"/> One-time <input type="checkbox"/> Recurring <input checked="" type="checkbox"/> N/A</p> <p>Other budget impacts: (revenue generating, match requirements, etc.)</p>	

<p>Operations Impacts (If N/A, please give a brief description as to why)</p>
<p>What impacts would the proposal have on historically excluded communities? This board seeks representation from impacted community members and from historically underrepresented geographic areas or marginalized communities, including communities of color and areas of the city of Spokane that are subject to disproportionate environmental and health disparities.</p>
<p>How will data be collected, analyzed, and reported concerning the effect of the program/policy by racial, ethnic, gender identity, national origin, income level, disability, sexual orientation, or other existing disparities? The Board will consider the effect of its policy and recommendations on impacted community members and will consider the effect on historically underrepresented geographic areas or marginalized communities, including low-income and communities of color and areas of the city of Spokane that have been subject to disproportionate environmental and health disparities</p>
<p>How will data be collected regarding the effectiveness of this program, policy or product to ensure it is the right solution? The board will work from an annual work plan. Execution of that plan will be part of the data collected determining the effectiveness of the Board.</p>
<p>Describe how this proposal aligns with current City Policies, including the Comprehensive Plan, Sustainability Action Plan, Capital Improvement Program, Neighborhood Master Plans, Council Resolutions, and others? This board aligns with and is charged with providing recommendations to implement the Comprehensive Plan and Sustainability Action Plan. It was also recommended as part of the Mayor’s Transition Committee.</p>

ORDINANCE NO C36557

An ordinance creating the Climate Resilience and Sustainability Board (CRSB); repealing Chapter 04.36 of Title 04 the Spokane Municipal Code; creating a new Chapter 04.41 to Title 04 of the Spokane Municipal Code.

WHEREAS, the City of Spokane produced its first Sustainability Action Plan in 2009; and

WHEREAS, the Spokane City Council officially adopted the City's first Sustainability Action Plan by an ordinance (No. C35519; SMC 15.05.030 B.) in 2017, which included a recommitment to the City's Greenhouse Gas Reduction Goals; and

WHEREAS, a 2018 ordinance (No. C35668; SMC 04.36) created the Sustainability Action Committee; and

WHEREAS, the Sustainability Action Committee was not empaneled by the Condon or Woodward administrations; and

WHEREAS, in 2018 the City Council created the Sustainability Action Subcommittee, reporting to the Council's Public Infrastructure, Environment and Sustainability Committee, to help move the City forward on sustainability and climate action (Resolution No. 2018-0110); and

WHEREAS, in 2021 the Spokane City Council adopted an updated Sustainability Action Plan that was developed by the City Council's Sustainability Initiatives Manager and the Sustainability Action Subcommittee in a multi-year process that engaged a large number and wide variety of community members and included six months of community engagement in reviewing the plan, and

WHEREAS, the 2021 Sustainability Action Plan established Goal 4, TL8, "Update the comprehensive plan to incorporate climate action and updated sustainability goals", and

WHEREAS, in 2021 the City Council codified in SMC 15.05.060 various reporting requirements concerning the status and progress of the City's efforts to implement the City's Sustainability Action Plan, and

WHEREAS, Mayor Brown's Transition Team committee focused on *Building a Resilient Future* recommended the creation of a Community Resiliency and Sustainability Board and further recommended the Sustainability Action Plan be integrated into the City's Comprehensive Plan; and

WHEREAS, the City is embarking on an update to the Comprehensive Plan to include a "Climate Element" with resilience and greenhouse gas emissions mitigation sub-elements as required by an update to the Growth Management Act that was adopted by

the State Legislature in 2023; and

WHEREAS, the legislation anticipates robust public engagement, and guidance provided by the Washington State Department of Commerce recommends the establishment of a “Climate Policy Advisory Committee” of community volunteers and other stakeholders to help shape the new Climate Element; and

WHEREAS, the City of Spokane seeks to bring people together to identify the co-benefits of sustainable actions and to move our community towards resilience in the face of climate change; and

NOW, THEREFORE, the City of Spokane does ordain:

Section 1. Chapter 04.36 entitled “Sustainability Action Committee” of Title 04 of the Spokane Municipal Code is repealed:

Section 2. There is enacted a new chapter 04.41 to Title 04 of the Spokane Municipal Code to read as follows:

Chapter 04.41	Climate Resilience and Sustainability Board
04.41.010	Purpose
04.41.020	Membership
04.41.030	Appointment and Term
04.41.040	Officers
04.41.050	Ancillary Powers
04.41.060	Duties and Responsibilities
04.41.070	Environmental Justice Considerations
04.41.080	Removal of Board Members

04.41.010 Purpose

The purpose of the Climate Resilience and Sustainability Board is to provide advice and recommendations to the Mayor, City Council, and community on the actions necessary to achieve the community’s sustainability and climate goals consistent with the City’s Comprehensive Plan, Sustainability Action Plan, environmental stewardship policies of the City as adopted by the City Council, and within the requirements and parameters set forth in state law.

04.41.020 Membership

A. The Climate Resilience and Sustainability Board shall consist of up to fifteen (15) voting members committed to achieving the goals of SMC Chapter 15.05 and implementing the policies and recommendations of the Sustainability Action Plan and the Climate Component of the Comprehensive Plan.

B. The Climate Resilience and Sustainability Board membership will consist of diverse and broad representation including but not limited to:

- 1) members of impacted communities facing disproportionate environmental and health disparities;
- 2) individuals with expertise in public health, emergency management, climate planning, or sustainability and resiliency initiatives;
- 3) business leaders and entrepreneurs with experience implementing sustainability and resiliency initiatives; and
- 4) students of secondary and postsecondary education institutions within the city of Spokane.

C. Climate Resilience and Sustainability Board members shall be at least sixteen years of age.

D. The City Council may appoint a city council member to serve as a liaison to the Board.

04.41.030 Appointment and Term

A. Term

1. Board members are nominated by the Mayor and appointed by the City Council.
2. The term of office shall be two years.
3. The terms of eight of the Board members shall expire in odd-numbered years.
4. The terms of seven of the Board members shall expire in even-numbered years.
5. Initial and subsequent Board members may be appointed to such shorter and/or longer terms as are necessary to achieve this term cycle.
6. No Board member shall serve more than four consecutive full terms.

B. Vacancy

1. Any vacancy may be filled for an unexpired term in the same manner as for an original appointment under this section as amended.
2. Appointment to fill the balance of an unexpired term where more than half of the unexpired term remains shall be considered a full term.

C. To achieve broad representation, city residency shall not be required to serve on the Climate Resilience and Sustainability Board; provided, however, a majority of the Board members shall consist of residents of the city, students of secondary or post-secondary institutions located within the city of Spokane, or business owners or non-profit employees located within the city limits of Spokane.

04.41.040 Officers

- A. The Climate Resilience and Sustainability Board shall select a Chair and Vice Chair of the Board from voting members appointed through the process outlined in SMC 04.41.030 for a term of two years. No person shall serve as chair for more than two consecutive two-year terms. The chair shall preside over meetings and the vice chair shall preside over meetings in the absence of the chair.

- B. The Climate Resilience and Sustainability Board may appoint other officers as it deems necessary.

04.41.050 Ancillary Powers

The Climate Resilience and Sustainability Board shall have the power to:

- A. Adopt internal rules of procedure to accomplish its duties;
- B. Use administrative support and staff as well as technical support from appropriate City departments and offices as necessary to assist the Board in the performance of its functions, maintenance of its records, and preparation of official correspondence;
- C. Organize itself, establish workgroups, committees, or subcommittees, establish annual work programs in consultation with the appropriate City staff, and delegate duties to such subordinate groups for the performance of its work.
- D. Access all relevant City of Spokane data and develop productive analytics and metrics;
- E. Host joint meetings with the City Council, Plan Commission, Transportation Commission and other relevant boards and commissions; and
- F. Host public events that encourage and support community engagement.

04.41.060 Duties and Responsibilities

The Climate Resilience and Sustainability Board shall provide advice and recommendations to the Mayor, City Council, and community on the actions necessary to achieve the community's sustainability and climate goals consistent with the City's Comprehensive Plan, Sustainability Action Plan, environmental stewardship policies of the City as adopted by the City Council, and within the requirements and parameters set forth in state law. Specifically, the Board shall have the following duties and responsibilities:

- A. Serve as the Climate Policy Advisory Team for the state-required Climate Element addition to the Comprehensive Plan, reviewing climate information gathered through engagement processes and providing recommendations on areas of focus and ensuring that climate goals and strategies are addressed in the housing, land use, transportation, public facilities, and other Comprehensive Plan elements;
- B. Consult with all City divisions and departments and relevant boards, committees, and commissions to recommend to the Mayor and Council funding opportunities and policy changes that advance resiliency, sustainability, and the policies that make up the Climate Element of the Comprehensive Plan;
- C. Identify opportunities for the City to collaborate with tribal, regional and statewide partners to advance the goals, principles, and strategies of the Sustainability Action Plan and Climate Element of the Comprehensive Plan;
- D. Provide recommendations and guidance for incorporating environmental and climate justice into City operations to limit the impacts of climate change in vulnerable and overburdened communities and reduce the cost-burden to low-income citizens as a result of implementing the Climate Element of the Comprehensive Plan;
- E. Consider research and best practices to make recommendations on climate and sustainability policies, programs, and projects as determined by the Board's annual work plan and upon request by City Council, City staff, and community members; and
- F. Establish an annual work plan in consultation with the appropriate City staff designated by the Mayor which shall be adopted by the City Council.

4.41.070 Environmental Justice Considerations

- A. In making and approving appointments to the Climate Resilience and Sustainability Board, the Mayor and City Council shall seek adequate representation from impacted community members and from historically underrepresented geographic areas or marginalized communities, including communities of color and areas of the city of Spokane that are subject to disproportionate environmental and health disparities.
- B. In performing its duties under SMC 4.41.070, the Climate Resilience and Sustainability Board shall consider the effect of its policy and recommendations on impacted community members and shall consider the effect on historically underrepresented geographic areas or marginalized communities, including low-income and communities of color and areas of the city of Spokane that have been subject to disproportionate environmental and health disparities.

4.41.080 Removal of Board Members

Climate Resilience and Sustainability Board members shall not be removed from office

by the City Council before the expiration of their terms except for cause based upon a determination of incapacity, incompetence, the presence of irreconcilable conflicts of interest, neglect of duty, or malfeasance, and upon the affirmative vote of five (5) Council members. No Board member shall be removed without written notice of the intent to remove and an opportunity to provide a written response to the notice.

Section 3. Severability. If any section, subsection, sentence, clause, phrase or word of this ordinance should be held to be invalid or unconstitutional by a court of competent jurisdiction, such invalidity or unconstitutionality thereof shall not affect the validity or constitutionality of any other section, subsection, sentence, clause, phrase or word of this ordinance.

Section 4. Clerical Errors. Upon approval by the city attorney, the city clerk is authorized to make necessary corrections to this ordinance, including scrivener's errors or clerical mistakes; references to other local, state, or federal laws, rules, or regulations; or numbering or referencing of ordinances or their sections and subsections.

PASSED by the City Council on _____

Council President

Attest:

Approved as to form:

City Clerk

City Attorney

Mayor

Date

Effective Date



Agenda Sheet for City Council:

Committee: Finance & Administration **Date:** 07/22/2024

Committee Agenda type: Discussion

Date Rec'd

7/24/2024

Clerk's File #

ORD C36558

Cross Ref #

Project #

Council Meeting Date: 08/12/2024

Submitting Dept

MAYOR

Bid #

Contact Name/Phone

ADAM 6779

Requisition #

Contact E-Mail

AMCDANIEL@SPOKANECITY.ORG

Agenda Item Type

First Reading Ordinance

Council Sponsor(s)

MCATHCART BWILKERSON ZZAPPONE

Agenda Item Name

0520 ORDINANCE REPEALING INACTIVE FUNDS (CODE CLEAN UP)

Agenda Wording

This ordinance amends certain funds with non-technical changes, and repeals certain municipal code sections related to inactive special revenue, debt service, capital projects and enterprise funds.

Summary (Background)

This ordinance repeals the following municipal code sections related to inactive special revenue, debt service, capital projects, and enterprise funds as detailed in the ordinance. This ordinance also amends certain funds with non-technical changes, also detailed within the ordinance.

Lease? NO Grant related? NO Public Works? NO

Fiscal Impact

Approved in Current Year Budget? N/A

Total Cost \$

Current Year Cost \$

Subsequent Year(s) Cost \$

Narrative

N/A -- code cleanup

Amount

Budget Account

Select	\$	#
Select	\$	#
Select	\$	#
Select	\$	#
	\$	#
	\$	#



Continuation of Wording, Summary, Approvals, and Distribution

Agenda Wording

Summary (Background)

Approvals

Dept Head

JONES, GARRETT

Division Director

Accounting Manager

BUSTOS, KIM

Legal

SCHOEDEL, ELIZABETH

For the Mayor

PICCOLO, MIKE

Additional Approvals

Distribution List

amcdaniel@spokanecity.org

mmurray@spokanecity.org

Committee Agenda Sheet

Finance & Administration Committee

Committee Date	7/22/2024
Submitting Department	Mayor's Office Finance and Administration
Contact Name	Adam McDaniel
Contact Email & Phone	amcdaniel@spokanecity.org
Council Sponsor(s)	
Select Agenda Item Type	<input type="checkbox"/> Consent <input checked="" type="checkbox"/> Discussion Time Requested: 1 minute
Agenda Item Name	Ordinance Repealing Inactive Funds (Code Clean up)
Proposed Council Action	<input checked="" type="checkbox"/> Approval to proceed to Legislative Agenda <input type="checkbox"/> Information Only
Summary (Background) *use the Fiscal Impact box below for relevant financial information	<p>This ordinance amends the following funds with non-technical changes:</p> <ul style="list-style-type: none"> • Updates the name of City Street Fund to Street Maintenance Fund (SMC 07.08.100) • Updates the name of the Cable TV Equipment Reserve Fund to the Channel Five TV Equipment Reserve Fund; Removes language no longer relevant (SMC 07.08.119) • Removes reference to the Opioid Abatement Council in the Cannabis Special Revenue Fund (SMC 07.08.159) <p>This ordinance repeals the following municipal code sections related to inactive special revenue, debt service, capital projects, and enterprise funds:</p> <ul style="list-style-type: none"> • Alcohol Rehabilitation Fund (SMC 07.08.105) • Employment and Training Funds (SMC 07.08.111) • Riverpoint Property Acquisition Fund (SMC 07.08.118) • Housing Stabilization Program Fund (SMC 07.08.120) • CBD Tree Maintenance Fund (SMC 08.18.126) • Spokane Regional Emergency Communication System Fund (SMC 07.08.128) • UDAG Fund (SMC 07.08.142) • Workforce Investment Funds (SMC 07.08.144) • Facilities Bond Redemption and Construction Funds (SMC 07.08.200) • City Hall Debt Service Fund (SMC 07.08.201) • Intermodal Facility Fund (SMC 07.08.308) • Capital Improvements 1999 Fund (SMC 07.08.309) • Rate Stabilization Fund (SMC 07.08.410)
Fiscal Impact	
Approved in current year budget? <input type="checkbox"/> Yes <input type="checkbox"/> No <input checked="" type="checkbox"/> N/A	
Total Cost: <u>N/A</u> Current year cost: N/A Subsequent year(s) cost:	
Narrative: <u>This ordinance has no financial impact.</u>	

<p>Funding Source <input type="checkbox"/> One-time <input type="checkbox"/> Recurring <input checked="" type="checkbox"/> N/A</p> <p>Specify funding source: Select Funding Source*</p> <p>Is this funding source sustainable for future years, months, etc?</p> <p>Expense Occurrence <input type="checkbox"/> One-time <input type="checkbox"/> Recurring <input checked="" type="checkbox"/> N/A</p> <p>Other budget impacts: (revenue generating, match requirements, etc.)</p>
<p>Operations Impacts (If N/A, please give a brief description as to why)</p>
<p>What impacts would the proposal have on historically excluded communities?</p> <p>N/A – Code Cleanup</p>
<p>How will data be collected, analyzed, and reported concerning the effect of the program/policy by racial, ethnic, gender identity, national origin, income level, disability, sexual orientation, or other existing disparities?</p> <p>N/A – Code Cleanup</p>
<p>How will data be collected regarding the effectiveness of this program, policy or product to ensure it is the right solution?</p> <p>N/A – Code Cleanup. These funds are no longer active.</p>
<p>Describe how this proposal aligns with current City Policies, including the Comprehensive Plan, Sustainability Action Plan, Capital Improvement Program, Neighborhood Master Plans, Council Resolutions, and others?</p> <p>N/A – Code Cleanup. These funds are no longer active.</p>

ORDINANCE NO C36558

An ordinance repealing inactive funds; amending Sections 07.08.100, 07.08.119, and 07.08.159; repealing Sections 07.08.105, 07.08.111, 07.08.118, 07.08.120, 07.08.126, 07.08.128, 07.08.142, 07.08.144, 07.08.200, 07.08.308, 07.08.309, and 07.08.410 of the Spokane Municipal Code.

WHEREAS, the administration seeks to update the municipal code to remove previously codified funds that are no longer active; and

WHEREAS, the repeal and amendment of these inactive funds has no fiscal impact;

NOW, THEREFORE, the City of Spokane does ordain:

Section 1. That Section 07.08.100 of the Spokane Municipal Code is amended to read as follows:

Section 07.08.100 ((City Street)) Street Maintenance Fund

There is created a fund to be known as the “((city street)) street maintenance fund” from which all expenditures shall be made for proper street purposes.

Section 2. That Section 07.08.105 of the Spokane Municipal Code is repealed.

Section 3. That Section 07.08.111 of the Spokane Municipal Code is repealed.

Section 4. That Section 07.08.118 of the Spokane Municipal Code is repealed.

Section 5. That Section 07.08.119 of the Spokane Municipal Code is amended to read as follows:

Section 07.08.119 ((Cable TV)) Channel Five Equipment Reserve Fund

A. There is established a special revenue fund to be known as the “((cable TV)) channel five equipment reserve fund”. ((into which will be deposited those various grants from Cox Cable Communications Company (TCL Cablevision of Washington by transfer of franchise (Resolution 1996-142, December 23, 1996)) as specified in Attachment 1 to the cable television franchise Ordinance C29733, passed July 2, 1990.))

B. This fund will be used to purchase various items of equipment to be used for a number of City cable programs ((as indicated in said Ordinance C29733 Attachment 1)) including, but not limited to:

1. Terminal and portable governmental equipment.

2. Educational equipment.
3. Video arraignment equipment; and
4. Fixed and field government production equipment.

Section 6. That Section 07.08.120 of the Spokane Municipal Code is repealed.

Section 7. That Section 07.08.126 of the Spokane Municipal Code is repealed.

Section 8. That Section 07.08.128 of the Spokane Municipal Code is repealed.

Section 9. That Section 07.08.142 of the Spokane Municipal Code is repealed.

Section 10. That Section 07.08.144 of the Spokane Municipal Code is repealed

Section 11. That Section 07.08.159 of the Spokane Municipal Code is amended to read as follows:

Section 07.08.159 Cannabis Special Revenue Fund

- A. Effective January 1, 2024, there is established a special revenue fund entitled the "Cannabis Special Revenue Fund" into which shall be paid all funds received by the City pursuant to RCW 69.50.540.
- B. As provided in the annual budget, the "Cannabis Special Revenue Fund" is appropriated as follows:
 - a. No less than \$500,000 shall be appropriated on an annual basis to the general fund for support of the Spokane Police Department; and
 - b. The balance of the Cannabis Special Revenue Fund shall be appropriated to provide for drug abuse prevention, education and general drug enforcement, ~~((to several City departments operating such programs, including but not limited to the Spokane Police Department, and the Opioid Abatement Council established under [chapter 04.39](#) of the Spokane Municipal Code))~~
- C. The city council may also provide for additional revenues to be paid into Cannabis Special Revenue Fund from time to time from any available funds of the City.

Section 12. That Section 07.08.200 of the Spokane Municipal Code is repealed.

Section 13. That Section 07.08.201 of the Spokane Municipal Code is repealed.

Section 14. That Section 07.08.308 of the Spokane Municipal Code is repealed.

Section 15. That Section 07.08.309 of the Spokane Municipal Code is repealed.

Section 16. That Section 07.08.410 of the Spokane Municipal Code is repealed.

PASSED by the City Council on _____

Council President

Attest:

Approved as to form:

City Clerk

City Attorney

Mayor

Date

Effective Date

**Agenda Sheet for City Council:****Committee:** Finance & Administration **Date:** 07/22/2024**Committee Agenda type:** Discussion**Date Rec'd**

7/24/2024

Clerk's File #

ORD C36559

Cross Ref #**Project #****Council Meeting Date:** 08/12/2024**Submitting Dept**

MAYOR

Bid #**Contact Name/Phone**

ADAM 6779

Requisition #**Contact E-Mail**

AMCDANIEL@SPOKANECITY.ORG

Agenda Item Type

First Reading Ordinance

Council Sponsor(s)

MCATHCART BWILKERSON ZZAPPONE

Agenda Item Name

ORDINANCE AMENDING SERS BOARD MEMBERSHIP

Agenda Wording

The Spokane Employees' Retirement System (SERS) Board administers the retirement system and retirement fund for City of Spokane employees except police and fire department employees.

Summary (Background)

As part of the comprehensive budget review process, the Mayor seeks to add additional financial expertise to the administration of the retirement system and Employees' Retirement Fund with the goal of improving overall retirement system health and performance.

Lease? NO

Grant related? NO

Public Works? NO

Fiscal Impact

Approved in Current Year Budget? N/A

Total Cost

\$

Current Year Cost

\$

Subsequent Year(s) Cost

\$

Narrative**Amount****Budget Account**

Select

\$

#

Select

\$

#

Select

\$

#

Select

\$

#

\$

#

\$

#

Committee Agenda Sheet

Finance & Administration Committee

Committee Date	July 22nd, 2024
Submitting Department	Mayor's Office
Contact Name	Adam McDaniel
Contact Email & Phone	amcdaniel@spokanecity.org
Council Sponsor(s)	
Select Agenda Item Type	<input type="checkbox"/> Consent <input checked="" type="checkbox"/> Discussion Time Requested: 5 minutes
Agenda Item Name	Ordinance Amending SERS Board Membership
Proposed Council Action	<input checked="" type="checkbox"/> Approval to proceed to Legislative Agenda <input type="checkbox"/> Information Only
Summary (Background) *use the Fiscal Impact box below for relevant financial information	<p>The Spokane Employees' Retirement System (SERS) Board administers the retirement system and retirement fund for City of Spokane employees except police and fire department employees.</p> <p>The SERS Board membership is governed by SMC 04.14.040 and currently consists of seven members:</p> <ul style="list-style-type: none"> • 3 members are nominated by the Mayor and appointed by the City Council. Currently, a City Council member assumes one of these positions. • 3 members are City of Spokane employees eligible for the retirement system elected by City of Spokane employees eligible for the system. • 1 member is appointed by the other six board members. He or she may not be an employee or elected official in the city. <p>The SERS Board has the power to direct investments of the retirement fund, change the rates of contribution, and adopt mortality and service tables to determine retirement benefit calculations.</p> <p>As part of the comprehensive budget review process, the Mayor seeks to add additional financial expertise to the administration of the retirement system and Employees' Retirement Fund with the goal of improving overall retirement system health and performance. After conversations and with support of the SERS Board members representing employees, this ordinance adds the Mayor or designee to the SERS and an additional employee representative to take the Board composition to nine members. It also clarifies that one of the Council appointments is a City Council member.</p>
<p>Fiscal Impact</p> <p>Approved in current year budget? <input type="checkbox"/> Yes <input type="checkbox"/> No <input checked="" type="checkbox"/> N/A</p> <p>Total Cost: <u>N/A</u></p> <p style="padding-left: 20px;">Current year cost: N/A</p> <p style="padding-left: 20px;">Subsequent year(s) cost:</p> <p>Narrative: <u>This ordinance has no financial impact.</u></p> <p>Funding Source <input type="checkbox"/> One-time <input type="checkbox"/> Recurring <input checked="" type="checkbox"/> N/A</p> <p>Specify funding source: Select Funding Source*</p> <p>Is this funding source sustainable for future years, months, etc?</p>	

Expense Occurrence One-time Recurring N/A

Other budget impacts: (revenue generating, match requirements, etc.)

Operations Impacts (If N/A, please give a brief description as to why)

What impacts would the proposal have on historically excluded communities?

This ordinance impacts internal City operations only.

How will data be collected, analyzed, and reported concerning the effect of the program/policy by racial, ethnic, gender identity, national origin, income level, disability, sexual orientation, or other existing disparities?

Each year, the SERS Board produces a comprehensive year-end annual report that provides the fund's financial statement, actuarial data, and information related to investments. This report does not collect or provide demographic information. SERS annual reports may be found at spokanesers.org.

How will data be collected regarding the effectiveness of this program, policy or product to ensure it is the right solution?

The addition of the Mayor or designee is intended to add additional expertise and Finance Division support to the SERS Board with the goal of improving overall retirement system health and performance. Data will be collected and reported through the SERS Annual report.

Describe how this proposal aligns with current City Policies, including the Comprehensive Plan, Sustainability Action Plan, Capital Improvement Program, Neighborhood Master Plans, Council Resolutions, and others?

City of Spokane Charter Section 24

Spokane Municipal Code 03.05

Spokane Municipal Code 04.14

ORDINANCE NO. C36559

An ordinance relating to the membership of the Spokane Employees' Retirement System Board; amending SMC section 4.14.040.

WHEREAS, Spokane Employees' Retirement System (SERS) Board administers the retirement system and retirement fund for City of Spokane employees and elected officials except police and fire department employees; and

WHEREAS, SERS Board has the power to direct investments of the retirement fund, change the rates of contribution, and adopt mortality and service tables to determine retirement benefit calculations; and

WHEREAS, SERS Board membership is governed by SMC 04.14.040 and currently consists of seven members with equal employee and Council appointees and one member selected by the other six members; and

WHEREAS, as part of the comprehensive budget review process, the Mayor seeks to add additional financial expertise to the administration of the retirement system and Employees' Retirement Fund with the goal of improving overall retirement system health and performance.

NOW, THEREFORE, the City of Spokane does ordain:

Section 1. That SMC section 4.14.040 is amended to read as follows:

4.14.040 Membership – Selection

A. The board consists of ~~((seven (7)))~~ nine (9) members.

1. Three (3) board members are appointed by the city council. One of the board member appointments is a council member.

2. ~~((Three (3)))~~ four (4) board members are elected from employees eligible for the retirement system by such eligible employees; ~~((and))~~

3. One (1) board member, the Mayor or the Mayor's designee.

~~((3))~~ 4. One (1) board member, who may not be an elected official or employee of the City, is appointed by the other ~~((six (6)))~~ eight (8) board members.

B. Terms.

1. The board members appointed by the city council serve at the pleasure of the city council.

2. The elected employee board members serve staggered ~~((three))~~ four-year terms commencing on the first Monday in July.

3. The Mayor or designee serves at the discretion of the Mayor during the Mayor's term of office.

~~((3))~~ 4. The ~~((seventh))~~ ninth board member serves a four-year term.

4. A vacancy is filled and a replacement is made in the same manner as original selections, except that a vacancy in one of the elected employee positions is filled by appointment by the other ~~((two))~~ three (or a minimum of two) elected employee board members, which appointment is until the next annual election.

PASSED by the City Council on _____

Council President

Attest:

Approved as to form:

City Clerk

City Attorney

Mayor

Date

Effective Date



Agenda Sheet for City Council:

Committee: Urban Experience **Date:** 07/08/2024

Committee Agenda type: Consent

Date Rec'd 7/8/2024

Clerk's File # ORD C36548

Cross Ref # RES 2024-0066

Project #

Council Meeting Date: 07/22/2024

Submitting Dept COMMUNITY AND ECONOMIC **Bid #**

Contact Name/Phone STEVE X6835 **Requisition #**

Contact E-Mail SMACDONALD@SPOKANECITY.ORG

Agenda Item Type First Reading Ordinance

Council Sponsor(s) ZZAPPONE JBINGLE KKLITZKE

Agenda Item Name 0750 - ORDINANCE FOR SALES TAX DEFERRAL PROGRAM

Agenda Wording

Ordinance for a Sales Tax Deferral Program for redevelopment of underutilized commercial property

Summary (Background)

Senate Bill 6175, passed by the legislature this past session, authorizes the City to establish a sales and use tax deferral program to promote the redevelopment of underutilized commercial property for affordable housing. The ordinance: • Updates SMC 08.07D to a new name (Sales and Use Tax Deferral Program for Underdeveloped Urban Land Redevelopment) to eliminate confusion with other sales and use tax deferral programs for affordable housing.

Lease? NO Grant related? NO Public Works? NO

Fiscal Impact

Approved in Current Year Budget? N/A

Total Cost \$

Current Year Cost \$

Subsequent Year(s) Cost \$

Narrative

Amount

Budget Account

Select \$ #

Select \$ #

Select \$ #

Select \$ #

Select \$ #

Select \$ #

Committee Agenda Sheet

Urban Experience Committee

Committee Date	7/8/2024
Submitting Department	Mayor's Office Planning & Economic Development
Contact Name	Steve MacDonald
Contact Email & Phone	smcdonald@spokanecity.org
Council Sponsor(s)	<u>Zappone</u>
Select Agenda Item Type	<input type="checkbox"/> Consent <input checked="" type="checkbox"/> Discussion Time Requested: 5 minutes
Agenda Item Name	Resolution and Ordinance for a Sales Tax Deferral Program for redevelopment of underutilized commercial property
Proposed Council Action	<input checked="" type="checkbox"/> Approval to proceed to Legislative Agenda <input type="checkbox"/> Information Only
Summary (Background) *use the Fiscal Impact box below for relevant financial information	<p>Senate Bill 6175, passed by the 2024 Washington Legislature and enacted as Chapter 332, Laws of 2024, authorizes the City to establish a sales and use tax deferral program to promote the redevelopment of underutilized commercial property for affordable housing.</p> <p>This resolution:</p> <ul style="list-style-type: none"> • declares the City's intention to establish a sales and use tax deferral program to encourage redevelopment of underutilized commercial property for affordable housing. • Sets the public hearing date for the ordinance for August 12th. <p>The ordinance:</p> <ul style="list-style-type: none"> • Updates SMC 08.07D to a new name (Sales and Use Tax Deferral Program for Underdeveloped Urban Land Redevelopment) to eliminate confusion with other sales and use tax deferral programs for affordable housing. • Consistent with SB 6175, establishes a new Chapter SMC 08.07E setting forth the application, appeals, approval process, and reporting requirements for the sales tax deferral program to encourage the redevelopment of underutilized commercial property.
Fiscal Impact Approved in current year budget? <input type="checkbox"/> Yes <input type="checkbox"/> No <input checked="" type="checkbox"/> N/A Total Cost: Click or tap here to enter text. Current year cost: Subsequent year(s) cost:	
Narrative: Please provide financial due diligence review, as applicable, such as number and type of positions, grant match requirements, summary type details (personnel, maintenance and supplies, capital, revenue), impact on rates, fees, or future shared revenue	
Funding Source <input type="checkbox"/> One-time <input type="checkbox"/> Recurring <input checked="" type="checkbox"/> N/A Specify funding source: Reallocation Is this funding source sustainable for future years, months, etc?	

Expense Occurrence One-time Recurring N/A

Other budget impacts: (revenue generating, match requirements, etc.)

Operations Impacts (If N/A, please give a brief description as to why)

What impacts would the proposal have on historically excluded communities?

The purpose of this sales and use tax deferral program is to provide additional affordable housing.

How will data be collected, analyzed, and reported concerning the effect of the program/policy by racial, ethnic, gender identity, national origin, income level, disability, sexual orientation, or other existing disparities?

The Planning and Economic Development team will track affordable housing units developed as a result of this program.

How will data be collected regarding the effectiveness of this program, policy or product to ensure it is the right solution?

This program automatically expires ten years from the adoption of the ordinance. Success of the program will be determined by the number of affordable housing units constructed as a result of this program.

Describe how this proposal aligns with current City Policies, including the Comprehensive Plan, Sustainability Action Plan, Capital Improvement Program, Neighborhood Master Plans, Council Resolutions, and others?

This program was a high legislative priority for the City of Spokane and aligns with our affordable housing goals in the Comprehensive Plan and Housing Action Plan.

ORDINANCE C36548

An ordinance relating to the establishment of a sales and use tax deferral program for affordable housing; retitling chapter 08.07D of the Spokane Municipal Code (SMC); and enacting a new chapter 08.07E to Title 08 of the SMC.

WHEREAS, in 2023, the City established chapter 08.07D SMC titled “Sales and Use Tax Deferral Program for Affordable Housing” to address redevelopment of underdeveloped urban land consistent with chapter 82.92 RCW; and

WHEREAS, chapter 8.07D SMC allows for infill development of former surface parking lots for to create affordable housing; and

WHEREAS, in 2024, the Washington State Legislature enacted Senate Bill 6175, which provides qualifying cities the legislative authority to enact a sales and use tax deferral program to encourage redevelopment of underutilized commercial property located in urban areas; and

WHEREAS, the State of Washington’s sales and use tax is 6.5 percent, while the City of Spokane’s is an additional 2.5 percent, thus equaling a 9 percent sales and use tax; and

WHEREAS, the deferral amount is the entire 9 percent sales and use tax; and

WHEREAS, there are many existing buildings located in downtown centers near work and services where there is underutilized commercial property that can be redeveloped into affordable housing; and

WHEREAS, to encourage the redevelopment of underutilized commercial property in the downtown center, the City of Spokane may create a sales and use tax deferral program to align with Senate Bill 6175 and hereby does; and

WHEREAS, as required pursuant to Senate Bill 6175, the City Council adopted Resolution 2024-0066, the Resolution of Intent to establish this program, at the July 22, 2024 Legislative Session and notices for the August 12, 2024 hearing were published on _____, 2024 in the City of Spokane Official Gazette; and

WHEREAS, to align with chapter 82.92 RCW and avoid confusion within the SMC with the establishment of the new chapter 08.07E SMC, which will also create a sales and use tax deferral program for affordable housing, Chapter 08.07D SMC needs to be renamed to identify it is for the redevelopment of underdeveloped urban land.

NOW THEREFORE, the City of Spokane does ordain:

Section 1. That the title to chapter 08.07D of Title 08 of the Spokane Municipal Code is retitled as follows:

Chapter 08.07D Sales and Use Tax Deferral Program for ((Affordable Housing)) Underdeveloped Urban Land Redevelopment

Section 2. That there is enacted a new chapter 08.07E to Title 08 of the Spokane Municipal Code to read as follows:

Chapter 08.07E Sales and Use Tax Deferral Program for Underutilized Commercial Property

SMC 08.07E.010	Purpose and Intent
SMC 08.07E.020	Definitions
SMC 08.07E.030	Application Process
SMC 08.07E.040	Approval Process
SMC 08.07E.050	Appeals Process
SMC 08.07E.060	Application Fee
SMC 08.07E.070	Additional Requirements, Conditions, and Obligations
SMC 08.07E.080	Annual Report
SMC 08.07E.090	Application to the Department
SMC 08.07E.100	Voluntary Discontinuance
SMC 08.07E.110	Transfer of Ownership
SMC 08.07E.120	Multi-family Tax Exemption
SMC 08.07E.130	Sunset

Section 08.07E.010 Purpose and Intent

The purpose of this chapter is to authorize a sales and use tax deferral program to assist the City of Spokane and increase more affordable housing units in targeted urban areas by incentivizing the redevelopment of underutilized commercial property in the urban core.

Section 08.07E.020 Definitions

As used in this chapter:

A. "Affordable housing" means:

1. Homeownership housing intended for owner occupancy to low-income households whose monthly housing costs, including utilities other than telephone, do not exceed 30 percent of the household's monthly income;

2. "Rental housing" for low-income households whose monthly housing costs, including utilities other than telephone, do not exceed 30 percent of the household's monthly income.
- B. "Applicant" means an owner of commercial property.
 - C. "City" means the City of Spokane, acting through the Director of Community and Economic Development and/or the City Council, as provided in this chapter.
 - D. "Conditional recipient" means an owner of commercial property granted a conditional certificate of program approval under this chapter, which includes any successor owner of the property.
 - E. "Department" means the Washington State Department of Revenue.
 - F. "Director" means the Director of Spokane Department of Community and Economic Development or the Director's designee.
 - G. "Eligible investment project" means an investment project that is located in a city and receiving a conditional certificate of program approval.
 - H. "Governing authority" means the local legislative authority of a city having jurisdiction over the property for which a deferral may be granted under this chapter.
 - I. "Household" means a single person, family, or unrelated persons living together.
 - J. "Initiation of construction" means the date that a building permit is issued under the building code adopted under RCW 19.27.031 for construction of the qualified building, if the underlying ownership of the building vests exclusively with the person receiving the economic benefit of the deferral.
 1. "Initiation of construction" does not include soil testing, site clearing and grading, site preparation, or any other related activities that are initiated before the issuance of a building permit for the construction of the foundation of the building.
 2. If the investment project is a phased project, "initiation of construction" applies separately to each phase.
 - K. "Investment project" means an investment in multifamily housing, including labor, services, and materials incorporated in the planning, installation, and

construction of the project. "Investment project" includes investment in related facilities such as playgrounds and sidewalks as well as facilities used for business use for mixed-use development.

- G. "Low-income household" means a single person, family, or unrelated persons living together whose adjusted income is at or below 80 percent of the median family income adjusted for family size, for the county, city, or metropolitan statistical area, where the project is located, as reported by the United States department of housing and urban development.
- H. "Multifamily housing" means a building or a group of buildings having four or more dwelling units not designed or used as transient accommodations and not including hotels and motels. Multifamily units may result from rehabilitation or conversion of vacant, underutilized, or substandard buildings to multifamily housing.
- I. "Owner" means the property owner of record.
- J. "Underutilized commercial property" means an entire property, or portion thereof, currently used or intended to be used by a business for retailing or office-related or administrative activities. If the property is used partly for a qualifying use and partly for other purposes, the applicable tax deferral must be determined by apportionment of the costs of construction under rules adopted by the department. For the purposes of this subsection, "qualifying use" means used or intended to be used by a business for retailing or office-related or administrative activities.

Section 08.07E.030 Application Process

An owner of underutilized commercial property seeking a sales and use tax deferral for conversion of a commercial building to provide affordable housing under this chapter on an investment project must complete the following procedures:

- A. The owner must apply to the City in writing, on forms adopted by the Spokane Department of Community and Economic Development. The application must contain the following:
 - 1. Information setting forth the grounds supporting the requested deferral including information indicated on the application form or in the guidelines;
 - 2. A description of the investment project and site plan, and other information requested;
 - 3. A statement of the expected number of affordable housing units to be created;

4. A statement that the applicant is aware of the potential tax liability involved if the investment project ceases to be used for eligible uses under this chapter;
 5. A statement that the applicant is aware that the investment project must be completed within three years from the date of approval of the application;
 6. A statement that the applicant is aware that the governing authority or the city official authorized by the governing authority may extend the deadline for completion of construction or rehabilitation for a period not to exceed 24 consecutive months; and
 7. A statement that the applicant would not have built in this location but for the availability of the tax deferral under this chapter.
- B. The applicant must verify the application by oath or affirmation; and
- C. The application must be accompanied by the application fee, if any, required under this chapter; and.
- D. The Director, with the approval of the Spokane City Council, may permit the applicant to revise an application before final action by the City on the application.

Section 08.07E.040 Approval Process

The Director may approve the application and grant a conditional certificate of program approval if it finds that:

- A. (1) The investment project is set aside primarily for multifamily housing units and the applicant commits to renting or selling at least 10 percent of the units as affordable housing to low-income households. In a mixed use project, only the ground floor of a building may be used for commercial purposes with the remainder dedicated to multifamily housing units; and (2) the applicant commits to any additional affordability and income eligibility conditions adopted by the local government under this chapter not otherwise inconsistent with this chapter;
- B. The investment project is, or will be, at the time of completion, in conformance with all local plans and regulations that apply at the time the application is approved;
- C. The investment project will occur on land that constitutes, at the time of application, underutilized commercial property;
- D. The area where the investment project will occur is located within an area zoned for residential or mixed uses;

- E. The terms and conditions of the implementation of the development meets the requirements of this chapter and any requirements of the city that are not otherwise inconsistent with this chapter;
- F. The land where the investment project will occur was not acquired through a condemnation proceeding under Title 8 RCW; and
- G. All other requirements of this chapter have been satisfied as well as any other requirements of the city that are not otherwise inconsistent with this chapter.;

Section 08.07E.050 Appeals Process

- A. The City must approve or deny an application filed under this chapter within 90 days after receipt of the application.
- B. If the application is approved, the City must issue the applicant a conditional certificate of program approval. The certificate must contain a statement by the Director of Community and Economic Development that the investment project as described in the application will comply with the required criteria of this chapter.
- C. If the application is denied by the City, the City must state in writing the reasons for denial and send the notice to the applicant at the applicant's last known address within 10 days of the denial.
- D. Upon denial of an application by the City, an applicant may appeal the denial to the City's Hearing Examiner within 30 days after receipt of the denial. The appeal before the Hearing Examiner must be based upon the record made before the City with the burden of proof on the applicant to show that there was no substantial evidence to support the City's decision.
- E. The decision of the City on appeal is final.

Section 08.07E.060 Application Fee

The City may establish an application fee. This fee shall not exceed an amount determined to be required to cover the cost to be incurred by the City in administering the program under this chapter and shall be reviewed and approved by the City Council on an annual basis. The application fee must be paid at the time the application for program approval is filed.

Section 08.07E.070 Additional Requirements, Conditions, and Obligations

- A. Within 30 days of the issuance of a certificate of occupancy by the City for an eligible investment project, the conditional recipient must file with the City the following:

1. A description of the work that has been completed and a statement that the eligible investment project qualifies the property for a sales and use tax deferral under this chapter;
 2. A statement of the new affordable housing to be offered as a result of the conversion of underutilized commercial property to multifamily housing; and
 3. A statement that the work has been completed within three years of the issuance of the conditional certificate of program approval.
- B. Within 30 days after receipt of the statements required under subsection (A) of this section, the City must determine and notify the conditional recipient as to whether the work completed and the affordable housing to be offered are consistent with the application and the contract approved by the City, and the investment project continues to qualify for a tax deferral under this chapter. The conditional recipient must notify the Department within 30 days from receiving the City's determination.
- C. The City must notify the conditional recipient within 30 days that a tax deferral under this chapter is denied if the City determines that:
1. The work was not completed within three years of the application date;
 2. The work was not constructed consistent with the application or other applicable requirements;
 3. The affordable housing units to be offered are not consistent with the application and criteria of this chapter; or
 4. The owner's property is otherwise not qualified for a sales and use tax deferral under this chapter.
- D. If the City finds that the work was not completed within the required time period due to circumstances beyond the control of the conditional recipient and that the conditional recipient has been acting and could reasonably be expected to act in good faith and with due diligence, the Director, with the approval of the City Council, may extend the deadline for completion of the work for a period not to exceed 24 consecutive months, and must notify the Department of the extension.
- F. In the event the City determines the conditional recipient is not entitled to a sales and use tax deferral under this Section 08.07D.080, the conditional recipient may appeal a decision by the City to the City's Hearing Examiner within 30 days after receipt of the denial. The appeal before the Hearing Examiner must be based upon the record made before the City with the burden of proof on the applicant to show that there was no substantial evidence to support the City's decision. The conditional recipient may appeal a decision by the City's Hearing Examiner to deny

a deferral of sales and use taxes in superior court under RCW 34.05.510 through 34.05.598 if the appeal is filed within 30 days of notification by the City to the conditional recipient.

- G. Upon denial of the sales and use tax deferral by the City under this Section 08.07D.070, the City shall notify the Department, upon which taxes deferred under this chapter are immediately due and payable, subject to any appeal by the conditional recipient.

Section 08.07E.080 Annual Report

- A. Thirty days after the anniversary of the date of issuance of the certificate of occupancy and each year thereafter for ten years, the conditional recipient must file with the Director an annual report indicating the following:
1. A statement of the affordable housing units constructed in the property as of the anniversary date;
 2. A certification by the conditional recipient that the property has not changed use;
 3. A description of changes or improvements constructed after issuance of the certificate of occupancy; and
 4. Any additional information requested by the City.
- B. The conditional recipient of a deferral of taxes under this chapter must file a complete annual tax performance report with the Department pursuant to RCW 82.32.534 beginning the year the certificate of occupancy is issued and each year thereafter for 10 years.
- C. In the event the City issues a certificate of program approval under this chapter, it shall report annually by December 31st of each year, beginning in 2025, to the Washington Department of Commerce the following information:
1. The number of program approval certificates granted;
 2. The total number and type of buildings converted;
 3. The number of affordable housing units resulting from the conversion of underutilized commercial property to multifamily housing; and
 4. The estimated value of the sales and use tax deferral for each investment project receiving a program approval and the total estimated value of sales and use tax deferrals granted.

Section 08.07E.090 Application to the Department

- A. A conditional recipient must submit an application to the Department for a sales and use tax deferral before initiation of the construction of the investment project. In the case of an investment project involving multiple qualified buildings, applications must be made for, and before the initiation of construction of, each qualified building. The application must be made to the Department of Revenue in the form and manner prescribed by the Department. The application must include a copy of the conditional certificate of program approval issued by the City, estimated construction costs, time schedules for completion and operation, and any other information required by the Department.

Section 08.07E.100 Voluntary Discontinuance

- A. If a conditional recipient voluntarily opts to discontinue compliance with the requirements of this chapter, the recipient must notify the City and Department within 60 days of the change in use or intended discontinuance.
- B. If, after the Department has issued a sales and use tax deferral certificate and the conditional recipient has received a certificate of occupancy, the City finds that a portion of an investment project is changed or will be changed to disqualify the recipient for sales and use tax deferral eligibility under this chapter, the City must notify the Department and all deferred sales and use taxes are immediately due and payable.
- C. This section does not apply after ten years from the date of the certificate of occupancy.

Section 08.07E.110 Transfer of Ownership

- A. Transfer of investment project ownership does not terminate the deferral. The deferral is transferred subject to the successor meeting the eligibility requirements of this Section 08.07E and Chapter 82.____RCW.
- B. The transferor of an eligible project must notify the City and the Department of such transfer, in writing and whereupon the City will certify to the Department whether the successor meets the requirements of the deferral. The transferor must provide the information necessary for the Department to transfer the deferral. If the transferor fails to notify the City and the Department, all deferred sales and use taxes are immediately due and payable as provided in Chapter 82.____RCW.

Section 08.07E.120 Multi-family Tax Exemption

An owner of underutilized commercial property claiming a sales and use tax deferral under this chapter may also apply for the multiple-unit housing property tax exemption program under chapter 08.15 SMC and chapter 84.14 RCW. For applicants receiving the

property tax exemption under chapter 08.15 SMC and chapter 84.14 RCW, the amount of affordable housing units required for eligibility under this chapter is in addition to the affordability conditions in chapter 08.15 SMC and chapter 84.14 RCW.

Section 08.07E.130 Sunset

This sales and use tax deferral program shall expire ten (10) years from the effective date of this ordinance.

Section 3. Severability. If any section, subsection, sentence, clause, phrase or word of this ordinance should be held to be invalid or unconstitutional by a court of competent jurisdiction, such invalidity or unconstitutionality thereof shall not affect the validity or constitutionality of any other section, subsection, sentence, clause, phrase or words of this ordinance.

Section 4. Clerk Corrections. Upon approval by the city attorney, the city clerk is authorized to make necessary corrections to this ordinance, including scrivener's errors, or clerical mistakes; references to other local, state, or federal laws, rules, or regulations; or renumbering or referencing of ordinances or their sections and subsections.

ADOPTED by the City Council on _____.

Council President

Attest:

Approved as to form:

City Clerk

Assistant City Attorney

Mayor

Date

Effective Date



Agenda Sheet for City Council:

Committee: Urban Experience **Date:** 08/12/2024

Committee Agenda type: Discussion

Date Rec'd 8/1/2024

Clerk's File # ORD C36560

Cross Ref # RES 2024-0064

Project #

Council Meeting Date: 08/12/2024

Submitting Dept DEVELOPMENT SERVICES CENTER **Bid #**

Contact Name/Phone ELDON BROWN 6305 **Requisition #**

Contact E-Mail EBROWN@SPOKANECITY.ORG

Agenda Item Type Hearings

Council Sponsor(s) ZZAPPONE JBINGLE KKLITZKE

Agenda Item Name 4700 STREET VACATION OF THE ALLEY BETWEEN LEE & STONE FROM

Agenda Wording

Vacation of the alley between Lee & Stone from Broadway to Springfield as requested by Richard Clemson.

Summary (Background)

Property owners abutting the above described alley have applied to vacate the alley. However, one of the property owners along the alley is against the vacation (owner of parcel 35164.0713). The applicant has the required amount of signatures per the statutory requirement to request a hearing. They are aware of the neighbor's resistance however the applicant would still like to proceed to a hearing and plead their case to City Council.

Lease? NO Grant related? NO Public Works? NO

Fiscal Impact

Approved in Current Year Budget?

Total Cost \$

Current Year Cost \$

Subsequent Year(s) Cost \$

Narrative

Amount

Budget Account

Select \$ #

Select \$ #

Select \$ #

Select \$ #

\$ #

\$ #

Committee Agenda Sheet

Urban Experience Committee

Submitting Department	Development Services
Contact Name & Phone	Eldon Brown – 509-625-6305
Contact Email	ebrown@spokanecity.org
Council Sponsor(s)	TBD
Select Agenda Item Type	<input type="checkbox"/> Consent <input checked="" type="checkbox"/> Discussion Time Requested: <u>5 Mins</u>
Agenda Item Name	Vacation of the alley between Lee & Stone, from Broadway to Springfield
Summary (Background)	Property owners abutting the above described alley have applied to vacate the alley. However, one of the property owners along the alley is against the vacation (owner of parcel 35164.0713). The applicant has the required amount of signatures per the statutory requirement to request a hearing. They are aware of the neighbor's resistance however the applicant would still like to proceed to a hearing and plead their case to City Council.
Proposed Council Action & Date:	Proposing to send to City Council for a Public Hearing
Fiscal Impact:	
Total Cost:	
Approved in current year budget? <input type="checkbox"/> Yes <input type="checkbox"/> No <input type="checkbox"/> N/A	
Funding Source <input type="checkbox"/> One-time <input type="checkbox"/> Recurring	
Specify funding source:	
Expense Occurrence <input type="checkbox"/> One-time <input type="checkbox"/> Recurring	
Other budget impacts: (revenue generating, match requirements, etc.)	
Operations Impacts	
What impacts would the proposal have on historically excluded communities? NA	
How will data be collected, analyzed, and reported concerning the effect of the program/policy by racial, ethnic, gender identity, national origin, income level, disability, sexual orientation, or other existing disparities? NA	
How will data be collected regarding the effectiveness of this program, policy or product to ensure it is the right solution? NA	
Describe how this proposal aligns with current City Policies, including the Comprehensive Plan, Sustainability Action Plan, Capital Improvement Program, Neighborhood Master Plans, Council Resolutions, and others? NA	

City of Spokane
Development Services Center
808 West Spokane Falls Blvd.
Spokane, WA 99201-3343
(509) 625-6300

ORDINANCE NO. C36560

An ordinance vacating the alley between Lee Street and Stone Street, from the south line of Broadway Avenue to the north line of Springfield Avenue.

WHEREAS, a petition for the vacation of the alley between Lee Street and Stone Street, from the south line of Broadway Avenue to the north line of Springfield Avenue, has been filed with the City Clerk representing 78.13 percent of the abutting property owners, and a hearing has been held on this petition before the City Council as provided by RCW 35.79; and

WHEREAS, the City Council has found that the public use, benefit and welfare will best be served by the vacation of said public way; -- NOW, THEREFORE,

The City of Spokane does ordain:

Section 1. That the alley between Lee Street and Stone Street, from the south line of Broadway Avenue to the north line of Springfield Avenue and located within the Southeast Quarter of Section 16, Township 25 North, Range 43 East, Willamette Meridian is hereby vacated. Parcel number not assigned.

Section 2. An easement is reserved and retained over and through the entire vacated area for the utility services of Avista Utilities, Lumen, and Comcast to protect existing and future utilities.

Passed the City Council _____

Council President

Attest: _____
City Clerk

Approved as to Form:

Assistant City Attorney

Mayor

Date: _____

Effective Date: _____

P2201690VACA



**Right-of-way Description:
The alley between Lee St. and Stone St.
From Broadway Ave to Springfield Ave**

Legend
 Proposed Vacation

THIS IS NOT A LEGAL DOCUMENT.
The information shown on this map is compiled from various sources and is subject to constant revision. Information shown on this map should not be used to determine the location of facilities in relationship to property lines, section lines, streets, etc.





CITY OF SPOKANE DEVELOPMENT SERVICES

808 West Spokane Falls Blvd, Spokane WA 99201-3343
(509) 625-6300 FAX (509) 625-6822

STREET VACATION REPORT June 12, 2024

LOCATION: Alley between Lee and Stone, from Broadway to Springfield.

PROPONENT: Richard Clemson

PURPOSE: Clean up the site and control access

HEARING: August 12, 2024

REPORTS:

AVISTA UTILITIES - Please reserve an easement over our existing utilities. No other concerns from Avista

ZAYO COMMUNICATIONS – Zayo has no comment and or objection to the attached vacation request.

COMCAST – Comcast has reviewed the vacation request. Enclosed is our system map showing coax running down that alley. Comcast can't approve of this vacation due to us needing access to our plant.

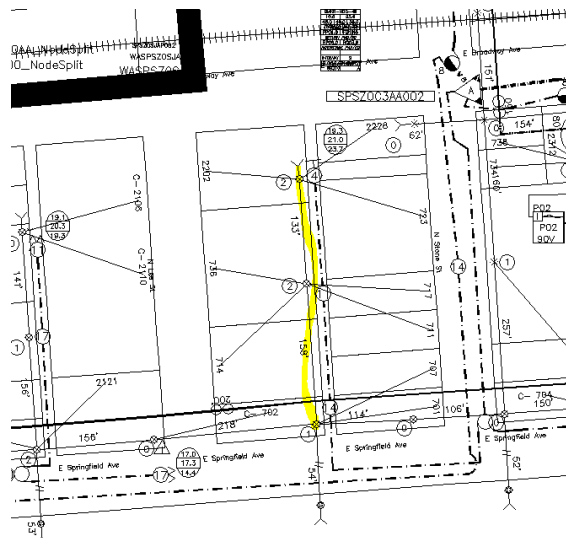

VERIZON/MCI METRO – Verizon/MCI Metro do not have facilities in this area.

TDS METROCOM – TDS Metrocom has no facilities here and will make note to exclude in future designs.

INLAND POWER – Inland Power & Light Co. has no facilities within the proposed vacation area.

EXTENET – There are no conflicts with the alleyway between N Lee Street and N Stone Street.

LUMEN – Lumen has fiber facilities in the right of way to be vacated and would like to retain utility easement rights within the vacating ordinance. These rights should provide for maintenance, construction, and reconstruction as needed.

INTEGRATED CAPITAL MANAGEMENT – No concerns

FIRE DEPARTMENT – No comments

NEIGHBORHOOD SERVICES - No comments

PARKS DEPARTMENT – No comments

NEIGHBOR – I am a resident of the area of this vacation request. I believe this should be reconsidered because the telephone lines must need to be maintained down the alley and have two of the residents who appear to use it for access to back yard.

DEVELOPER SERVICES – TRAFFIC DESIGN – No comments

DEVELOPER SERVICES – CURRENT PLANNING – It appears that parcel 35164.0707 uses the alley to access their garage. Parcel 35164.0708 uses the alley for access to their shop as they have ADA parking in the way and cannot access from Stone.

POLICE DEPARTMENT - No comments

SOLID WASTE MANAGEMENT – Solid Waste has no concerns

STREET DEPARTMENT – Curb returns on Springfield will need to be removed and replaced with standard curb across vacated alleyway matching cubing to the east and west.

WASTEWATER MANAGEMENT – Wastewater Management has no assets in the proposed vacation area. Therefore, provided onsite runoff is maintained and treated on site, we have no objection to vacating this property.

WATER DEPARTMENT - No comments

BICYCLE ADVISORY BOARD - No comments

RECOMMENDATION: That the petition be granted and a vacating ordinance be prepared subject to the following conditions:

1. An easement as requested by Century Link/Lumen, Avista Utilities, and Comcast shall be retained to protect existing and future utilities.
2. The plans for termination and closure of the alley must be submitted and accepted by Developer Services, prior to construction, and the improvements must be satisfactorily constructed or bonded for before final vacation approval.

This closure work must include the removal of the curb returns on the south side of the alley and full height curb and sidewalk must be placed across the entrance to the right-of-way. If access is still desired, a driveway approach must be placed across the entrance.

3. The proponent shall pay to the City of Spokane the assessed valuation for the vacated land as defined by the 2022 (time of application) information from the County Assessor's Office. This is calculated to be \$17,601.69 and is to be deposited to Budget Account #3200 49199 99999 39510.
4. That the final reading of the vacation be held in abeyance until all of the above conditions are met and that the above conditions are met by December 1, 2025.

Eldon Brown, P.E.
Principal Engineer – Planning & Development



March 21, 2022

Development Services Center/Spokane City Council
808 W. Spokane Falls Blvd
Spokane, WA 99201

Attn: Erik Johnson

RE: Vacation of Alley from E Springfield Ave to E Broadway Ave
Between N Lee St and N Stone St

Mr. Johnson,

Please find attached application for the vacation of the above located alley. The three listed property owners constitute a majority of land ownership. I was not able to contact the owners of the two parcels shown as both owners are renting out the properties. Neither parcel would be denied access to the public right of way should the vacation be approved. The majority owners would fence the vacated portions and incorporate into their respective parcels. The alley right of way is not required for public use. The majority landowners have been actively improving the neighborhood and cleaning up the area. The alley has been used by nuisance dumpers and suspicious traffic. Vacating this alley would be of benefit to the public by eliminating this problem and adding property to the tax rolls. There are electric power poles located in the alley, which would remain. The property on the south end of the alley has a sewer connection to Springfield which would also remain.

Thank you,
Richard Clemson
Owner of parcels:
35164.0704
35164.0716
35164.0705
35164.0706

RECEIVED

MAR 24 2022

PLANNING & DEVELOPMENT



Date MARCH 21, 2022

I hereby make application for the vacation of ALLEY FROM E. SPRINGFIELD TO BROADWAY
from BETWEEN N. LEE ST to N. STONE ST.

The reasons for the vacation are: SEE ATTACHED

Public benefits to be derived from the vacation are: SEE ATTACHED

Property Owner 1 Parcel Number 35164.0704, 35164.0716, 35164.0705, 35164.0706
 Proponent's (Record Owner's) Signature Richard Clemson
 Print Name RICHARD CLEMSON
 Email RICLEM@Q.COM Phone Number 509-994-3404
 Office Use Lot _____ Block _____ Addition _____

Property Owner 2 Parcel Number 35164.0708, 35164.0714, 35164.0715
 Proponent's (Record Owner's) Signature Pike Grant
 Print Name Pike Grant
 Email pike@angelsfamily.com Phone Number 509-535-9904
 Office Use Lot _____ Block _____ Addition _____

Property Owner 3 Parcel Number 35164.0701
 Proponent's (Record Owner's) Signature Tom Ingram
 Print Name TOM INGRAM
 Email WATER.KNIFE@YAHOO.COM Phone Number 509 953 0614
 Office Use Lot _____ Block _____ Addition _____

Property Owner 4 Parcel Number _____
 Proponent's (Record Owner's) Signature _____
 Print Name _____
 Email _____ Phone Number _____
 Office Use Lot _____ Block _____ Addition _____

RECEIVED

MAR 24 2022

PLANNING & DEVELOPMENT

Return completed application to:
City of Spokane, Development Services Center, 808 West Spokane Falls Boulevard, Spokane, WA 99201-3343

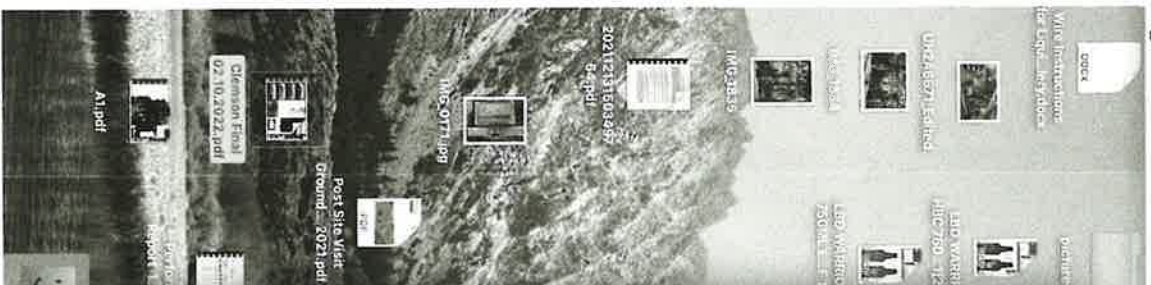

202112151503265
4-4-2011

Post Site Visit Ground - 2021.pdf

CHERRY STREET 02-10-2022.pdf

At.pdf

Wire Instructions for Equip. In-Place

UN246971.shtd

LEO WARRIN ABC 750 - 712

LEO WARRIN 750 W/HRBU 750 W/HRBU

IMC333.5

202112151503265

DXV - U.S. Dollar Index (DXY) - MarketWatch marketwatch.com
DXV overview, news and data on the U.S. Dollar in...

Charles Schwab Client Center client.schwab.com
Return to Schwab Mortgage Customer Cent...

Gold Price goldprice.org
GOLDPRICE.ORG - The No. 1 current gold price s...

Crude Oil Prices Today | OilPrice.com oilprice.com
Crude oil prices & gas price charts. Oil price cha...

Men's Basketball guobards.spokesmanreview.com
Main discussion on GU Men's Basketball!

cp.spokanecounty.org

Map of Spokane County parcels with a yellow highlighted area and red outlines.

Map navigation controls: +, -, search, etc.

Map layers: Tax Parcels, Districts, Permits, Zoning, Parcel History

SCOUT Spokane County

RECEIVED

MAR 24 2022

PLANNING & DEVELOPMENT

Block Area Alley

PETITIONERS

14

Measure More Info

Mon 6:07 PM



Agenda Sheet for City Council:

Committee: Urban Experience **Date:** 07/08/2024

Committee Agenda type: Discussion

Date Rec'd

7/8/2024

Clerk's File #

ORD C36552

Cross Ref #

Project #

Council Meeting Date: 07/22/2024

Submitting Dept

PLANNING & ECONOMIC

Bid #

Contact Name/Phone

KAYCEE X6194

Requisition #

Contact E-Mail

KDOWNEY@SPOKANECITY.ORG

Agenda Item Type

First Reading Ordinance

Council Sponsor(s)

ZZAPPONE KKLITZKE JBINGLE

Agenda Item Name

0650HIGHER INTENSITY RES. CODE UPDATE ASSOCIATED W/S LOGAN TOD

Agenda Wording

Higher intensity residential code update to amend SMC Sections 17C.111.205 and 17C.111.420 for South Logan TOD Implementation.

Summary (Background)

The South Logan Transit-Oriented Development (TOD) Plan, adopted by resolution on January 29, 2024, provides recommendations to support more connectivity and livability for the community, businesses, and organization in South Logan. As part of South Logan TOD Implementation, several recommendations are proposed for citywide impact. The proposed higher intensity residential code update to amend SMC Sections 17C.111.205 and 17C.111.420 align with the goals and recommendations of the South Logan

Lease? NO

Grant related? NO

Public Works? NO

Fiscal Impact

Approved in Current Year Budget? N/A

Total Cost

\$

Current Year Cost

\$

Subsequent Year(s) Cost

\$

Narrative

The S. Logan TOD Plan and FEIS, adopted by resolution on January 29, 2024, was funded through the TOD Implementation grant program via the WA Department of Commerce. Implementation of the South Logan TOD Plan relied on on-going and regular staff resources

Amount

Budget Account

Neutral

\$

#

Select

\$

#

Select

\$

#

Select

\$

#

Select

\$

#

Select

\$

#



Continuation of Wording, Summary, Approvals, and Distribution

Agenda Wording

Summary (Background)

TOD Plan and the City of Spokane Comprehensive Plan. The proposed amendments include increasing the maximum heights in the Residential Multifamily (RMF) and Residential High Density (RHD) zones and modifying open space requirements to support increased feasibility of higher intensity residential development. For the full code amendments please visit: <https://my.spokanecity.org/projects/south-logan-transit-oriented-development-project/>

Approvals

<u>Dept Head</u>	GARDNER, SPENCER
<u>Division Director</u>	GARDNER, SPENCER
<u>Accounting Manager</u>	ALBIN-MOORE, ANGELA
<u>Legal</u>	RICHMAN, JAMES
<u>For the Mayor</u>	JONES, GARRETT

Additional Approvals

Distribution List

smacdonald@spokanecity.org	kdowney@spokanecity.org
sgardner@spokanecity.org	tblack@spokanecity.org
tkimbrell@spokanecity.org	amccall@spokanecity.org

Committee Agenda Sheet

Urban Experience Committee

Committee Date	July 8, 2024
Submitting Department	Planning & Economic Development
Contact Name	KayCee Downey
Contact Email & Phone	kdowney@spokanecity.org , x6194
Council Sponsor(s)	<u>CM Zappone, CM Klitzke and CM Bingle</u>
Select Agenda Item Type	<input type="checkbox"/> Consent <input checked="" type="checkbox"/> Discussion Time Requested: 5 minutes
Agenda Item Name	Higher Intensity Residential Code Update Associated with South Logan TOD Implementation
Proposed Council Action	<input checked="" type="checkbox"/> Approval to proceed to Legislative Agenda <input type="checkbox"/> Information Only
Summary (Background) *use the Fiscal Impact box below for relevant financial information	<p>The South Logan Transit-Oriented Development (TOD) Plan, adopted by resolution on January 29, 2024, provides recommendations to support more connectivity and livability for the community, businesses, and organization in South Logan. As part of South Logan TOD Implementation, several recommendations are proposed for citywide impact.</p> <p>The proposed higher intensity residential code update to amend SMC Sections 17C.111.205 and 17C.111.420 align with the goals and recommendations of the South Logan TOD Plan and the City of Spokane Comprehensive Plan.</p> <p>The proposed amendments include increasing the maximum heights in the Residential Multifamily (RMF) and Residential High Density (RHD) zones and modifying open space requirements to support increased feasibility of higher intensity residential development.</p> <p>For the full code amendments please visit: https://my.spokanecity.org/projects/south-logan-transit-oriented-development-project/</p>
<p>Fiscal Impact</p> <p>Approved in current year budget? <input type="checkbox"/> Yes <input type="checkbox"/> No <input checked="" type="checkbox"/> N/A</p> <p>Total Cost: Click or tap here to enter text.</p> <p>Narrative: The South Logan TOD Plan and FEIS, adopted by resolution on January 29, 2024, was funded through the Transit-Oriented Development Implementation (TODI) grant program via the WA Department of Commerce. Implementation of the South Logan TOD Plan relied on on-going and regular staff resources.</p> <p>Funding Source <input type="checkbox"/> One-time <input type="checkbox"/> Recurring <input checked="" type="checkbox"/> N/A</p> <p>Specify funding source: Select Funding Source*</p> <p>Is this funding source sustainable for future years, months, etc? Click or tap here to enter text.</p> <p>Expense Occurrence <input type="checkbox"/> One-time <input type="checkbox"/> Recurring <input checked="" type="checkbox"/> N/A</p> <p>Other budget impacts: (revenue generating, match requirements, etc.)</p>	
Operations Impacts (If N/A, please give a brief description as to why)	
<i>What impacts would the proposal have on historically excluded communities?</i>	

The proposed text amendments are intended to support high quality transit, increase housing capacity and diversity, and promote affordability along the City Line bus rapid transit in the South Logan area and throughout Center and Corridor and higher intensity residential areas throughout Spokane. By focusing on development along transit lines and removing identified barriers to successful projects, the proposals are intended to support a diversity of uses and housing options near existing multimodal transportation options.

How will data be collected, analyzed, and reported concerning the effect of the program/policy by racial, ethnic, gender identity, national origin, income level, disability, sexual orientation, or other existing disparities?

The South Logan TOD Plan reviewed and analyzed environmental and social impacts of planned development and development alternatives as part of the process, following the guidance of the HEAL Act. An analysis of existing conditions established a baseline to inform the project with data on demographics, socioeconomics, housing and market conditions, land use and zoning, and infrastructure needs. The proposals are implementing the adopted Plan with no additional data collection.

How will data be collected regarding the effectiveness of this program, policy, or product to ensure it is the right solution?

The South Logan TOD Plan was developed after a 20-month community engagement process that sought input from residents, businesses, institutions, agency partners, and other subject matter experts. The proposals are implementing the recommendations of the adopted Plan. Additional community outreach and engagement occurred after draft ordinances were available to verify effectiveness of the implementation.

Describe how this proposal aligns with current City Policies, including the Comprehensive Plan, Sustainability Action Plan, Capital Improvement Program, Neighborhood Master Plans, Council Resolutions, and others?

The South Logan TOD Project is aligned with many City policies to better connect land use and transportation, expand and increase the housing supply including middle housing and affordable housing, and promote anti-displacement and equitable outcomes. This includes the Comprehensive Plan (Housing Chapter), Housing Action Plan, Sustainability Action Plan, and Transit-Oriented Development Framework Study, and Logan Neighborhood Identity Plan. The proposals are implementing the South Logan TOD Plan, which was adopted by resolution on January 29, 2024 after being determined to meet all relevant policies and plans.

ORDINANCE NO. C36552

AN ORDINANCE relating to maximum residential heights and multi-unit open space standards amending Spokane Municipal Code (SMC) Sections 17C.111.205 and 17C.111.420.

WHEREAS, in 2021, the Washington State Legislature appropriated \$2.5 million for cities to facilitate transit-oriented development in areas with light rail or fixed rail systems, bus rapid transit, high-frequency bus service or park and ride lots; and

WHEREAS, the City of Spokane was one of 11 communities that received the Transit-Oriented Development Implementation (TODI) grant for \$250,000 from the Washington Department of Commerce in 2021 to facilitate transit-oriented development and increase residential capacity in areas of high-capacity transit; and

WHEREAS, the City of Spokane prepared the Transit-Oriented Development (TOD) Framework Action Plan, adopted by resolution in May 2022 under RES 2022-0039, that identifies strategies best suited to Spokane for supporting TOD along new High-Performance Transit lines, including a focus on South Logan; and

WHEREAS, the City provided opportunities for meaningful public involvement and review in the South Logan TOD Plan and EIS process, including a community meeting consistent with RCW 43.21C.440; has considered all comments received; and, as appropriate, has modified the proposal or mitigation measures in response to comments, resulting in the Preferred Alternative analyzed in the FEIS; and

WHEREAS, the *Final South Logan TOD Plan and Final Environmental Impact Statement (FEIS)* was published on November 30, 2023 for final consideration; and

WHEREAS, on January 29, 2024 Spokane City Council adopted by resolution (RES 2024-0015) the Final South Logan TOD Plan and FEIS as a declaration of the subarea's desired future condition; and

WHEREAS, in order to facilitate the higher intensity residential development envisioned in the Plan, the adopted Final South Logan TOD Plan called for a review of higher intensity residential design standards, as well as permitted heights; and

WHEREAS, based on feedback from developers and the community, it was determined that modifications were required to the open space standards to increase feasibility of higher intensity residential development within the South Logan TOD project area while ensuring open space access for all residents; and

WHEREAS, based on feedback from developers and the community, it was determined that modifications were required to the maximum heights permitted in the

higher intensity residential zones to increase feasibility of development within the South Logan TOD project area; and

WHEREAS, for regulatory consistency throughout Spokane and to ensure the benefits of increased feasibility and access to open space, the amendments affect citywide development regulations; and

WHEREAS, on April 29, 2024, the Washington State Department of Commerce and appropriate state agencies were given the required 60-day notice of the City's intent to adopt updated development regulations; and

WHEREAS, the Spokane Plan Commission held public workshops on the provisions in this ordinance on March 13, April 10, April 24, May 22, and June 12 of this year; and

WHEREAS, a SEPA Determination of Nonsignificance and Checklist were issued by Planning Services on June 12, 2024; and

WHEREAS, prior to the Plan Commission public hearing, a legal notice was published in the *Spokesman-Review* on June 12 and June 19, 2024; and

WHEREAS, on June 19, 2024, the Planning Department staff finalized their Staff Report to the Spokane Plan Commission recommending approval of the provisions of this ordinance; and

WHEREAS, on June 26, 2024, the Spokane Plan Commission held a public hearing on the provisions of this ordinance and unanimously voted to recommend approval with conditions, as outlined in the Findings of Fact, Conclusions, and Recommendation signed June 28, 2024; and

WHEREAS, the City Council adopts the recitals set forth herein as its findings and conclusions in support of its adoption of this ordinance.

NOW, THEREFORE, the City of Spokane does ordain:

Section 1. That SMC Section 17C.111.205 be amended to read as follows:

Section 17C.111.205 Development Standards Tables

Development standards that apply within the residential zones are provided in Tables 17C.111.205-1 through 17C.111.205-3.

TABLE 17C.111.205-1 LOT DEVELOPMENT STANDARDS [1]
--

	RA	R1	R2	RMF	RHD
DENSITY STANDARDS					
Maximum density on sites 2 acres or less [2][3]	No maximum	No maximum	No maximum	No maximum	No maximum
Maximum density on sites larger than 2 acres [2]	10 units/acre	10 units/acre	20 units/acre	No maximum	No maximum
Minimum density [2]	4 units/acre	4 units/acre	10 units/acre	15 units/acre	15 units/acre
LOT DIMENSIONS FOR SUBDIVISIONS AND SHORT SUBDIVISIONS					
Minimum lot area	7,200 sq. ft.	1,200 sq. ft.	1,200 sq. ft.	1,200 sq. ft.	1,200 sq. ft.
Minimum lot width with no driveway approach [4]	40 ft.	15 ft.	15 ft.	15 ft.	15 ft.
Minimum lot width with driveway approach [4]	40 ft.	36 ft.	36 ft.	25 ft.	25 ft.
Minimum lot width within Airfield Overlay Zone	40 ft.	40 ft.	36 ft.	25 ft.	25 ft.
Minimum lot depth	80 ft.	80 ft.	40 ft.	N/A	N/A
Minimum lot frontage	40 ft.	Same as minimum lot width	Same as minimum lot width	Same as minimum lot width	Same as minimum lot width
MINIMUM LOT DIMENSIONS FOR UNIT LOT SUBDIVISIONS					
Minimum parent lot area	No minimum	No minimum	No minimum	No minimum	No minimum
Maximum parent lot area	2 acres	2 acres	2 acres	2 acres	2 acres
Minimum child lot area	No minimum	No minimum	No minimum	No minimum	No minimum
Minimum child lot depth	No minimum	No minimum	No minimum	No minimum	No minimum
LOT COVERAGE					
Maximum total building coverage [5][6][7]	50%	65%	80%	100%	100%
Maximum lot impervious coverage without engineer's stormwater drainage plan - not in ADC [5][8]	50%	60%	60%	N/A	N/A
Maximum lot impervious coverage without engineer's stormwater drainage plan - inside ADC [5][8]	40%	40%	40%	N/A	N/A
Notes:					
[1] Plan district, overlay zone, or other development standards contained in Title 17C SMC may supersede these standards.					

[2] See SMC 17C.111.210 for applicability of minimum and maximum density standards in the residential zones.

[3] Development within Airfield Overlay Zones is further regulated as described in SMC 17C.180.090, Limited Use Standards.

[4] Lots with vehicle access only from an alley are not considered to have a “driveway approach” for the purposes of this standard.

[5] Lot and building coverage calculation includes all primary and accessory structures.

[6] Building coverage for attached housing is calculated based on the overall development site, rather than individual lots.

[7] Developments meeting certain criteria relating to transit, Centers & Corridors, or housing affordability are given a bonus for building coverage. See SMC 17C.111.225 for detailed eligibility criteria.

[8] Projects may exceed impervious coverage requirements by including an engineer’s drainage plan in submittals, subject to review by the City Engineer as described in SMC 17D.060.135. “ADC” means Area of Drainage Concern.

TABLE 17C.111.205-2					
BUILDING AND SITING STANDARDS [1]					
	RA	R1	R2	RMF	RHD
PRIMARY BUILDINGS					
Floor area ratio	N/A	N/A	N/A	N/A	N/A
Maximum building footprint per primary building - lot area 7,000 sq. ft. or less	N/A	2,450 sq. ft.	2,450 sq. ft.	N/A	N/A
Maximum building footprint per primary building - lot area more than 7,000 sq. ft.	N/A	35%	35%	N/A	N/A
Maximum building height [2]	35 ft.	40 ft.	40 ft.	((40)) <u>55</u> ft.	((40)) <u>75</u> ft.
Minimum Setbacks					
Front	15 ft.	10 ft.	10 ft.	10 ft.	10 ft.
Interior side lot line - lot width 40 ft or less [3]	3 ft.	3 ft.	3 ft.	3 ft.	3 ft.
Interior side lot line - lot width more than 40 ft [4] [5]	5 ft.	5 ft.	5 ft.	5 ft.	5 ft.

Street side lot line – all lot widths	5 ft.	5 ft.	5 ft.	5 ft.	5 ft.
Attached garage or carport entrance from street	20 ft.	20 ft.	20 ft.	20 ft.	20 ft.
Rear	25 ft.	15 ft.	15 ft.	10 ft.	10 ft.
ACCESSORY DWELLING UNITS					
Maximum building footprint for accessory dwelling unit - lot area 5,500 sq. ft. or less	1,100 sq. ft.	1,100 sq. ft.	1,100 sq. ft.	1,100 sq. ft.	1,100 sq. ft.
Maximum building footprint for accessory dwelling unit - lots larger than 5,500 sq. ft.	15%	15%	15%	15%	15%
Maximum building height	25 ft.	25 ft.	25 ft.	25 ft.	25 ft.
Minimum side lot line setbacks [5] [6]	Same as Primary Structure				
Minimum rear setback with alley [4] [5] [6]	0 ft.	0 ft.	0 ft.	0 ft.	0 ft.
Minimum rear setback no alley	5 ft.	5 ft.	5 ft.	5 ft.	5 ft.
OTHER ACCESSORY STRUCTURES					
Maximum lot coverage for accessory structures – lots 5,500 sq. ft. or less	20%	20%	20%	See Primary Structure	See Primary Structure
Maximum lot coverage for accessory structures – lots larger than 5,500 sq. ft.	20%	15%	15%	See Primary Structure	See Primary Structure
Maximum building height	30 ft.	20 ft.	20 ft.	35 ft.	35 ft.
Minimum side lot line setbacks [4] [5] [6]	Same as Primary Structure				
Minimum rear setback with alley	0 ft.	0 ft.	0 ft.	0 ft.	0 ft.
Minimum rear setback no alley	5 ft.	5 ft.	5 ft.	5 ft.	5 ft.
OPEN SPACE [7]					

Minimum ((outdoor area)) <u>open space</u> per unit (([7])) [8]	250 sq. ft.	250 sq. ft.	250 sq. ft.	((200-sq.- ft.-)) Studio: 48 sq. ft. per unit 1- bedroom: 75 sq. ft. per unit 2+ bedrooms: 150 sq. ft. per unit	Studio: 48 sq. ft. per unit 1-bedroom: 75 sq. ft. per unit 2+ bedrooms: 100 sq. ft. per unit Sites 20,000 sq. ft. or less: 36 sq. ft. per unit
Minimum common ((outdoor area)) <u>open space</u> per unit as a substitute for private area - first six units	200 sq. ft.	200 sq. ft.	200 sq. ft.	((150-sq.- ft.-)) Studio: 48 sq. ft. per unit 1- bedroom: 75 sq. ft. per unit 2+ bedrooms: 150 sq. ft. per unit	Studio: 48 sq. ft. per unit 1-bedroom: 75 sq. ft. per unit 2+ bedrooms: 100 sq. ft. per unit Sites 20,000 sq. ft. or less: 36 sq. ft. per unit
Minimum common ((outdoor area)) <u>open space</u> per unit as a substitute for private area - all units after six	150 sq. ft.	150 sq. ft.	150 sq. ft.	((100-sq.- ft.-)) Studio: 36 sq. ft. per unit 1- bedroom: 48 sq. ft. per unit 2+ bedrooms:	Studio: ((48)) 36 sq. ft. per unit 1-bedroom: 48 sq. ft. per unit 2+ bedrooms: 48 sq. ft. per unit Sites 20,000 sq. ft. or less: 25 sq. ft. per unit

				48 sq. ft. per unit	
Notes:					
[1] Plan district, overlay zone, or other development standards contained in Title 17C SMC may supersede these standards.					
[2] Base zone height may be modified according to SMC 17C.111.230, Height.					
[3] Certain elements such as covered porches may extend into the front setback. See SMC 17C.111.235, Setbacks.					
[4] There is an additional angled setback from the interior side lot line. Refer to SMC 17C.111.230(C) and 17C.111.235(E) for more detail.					
[5] Setbacks for a detached accessory structure and a covered accessory structure may be reduced to zero feet with a signed waiver from the neighboring property owner as specified in SMC 17C.111.240(C).					
[6] Accessory structures may be subject to an additional side setback adjacent to streets as specified in 17C.111.240(C)(5).					
[7] Residential units with a continuous pedestrian route as defined in SMC Section 17C.111.420(B) from the property boundary to a public park within 800 feet shall have a minimum of not more than 36 square feet of open space per unit.					
([7]) [8] Common ((outdoor area)) open space may be substituted for private ((outdoor area)) open space according to SMC 17C.111.310.					

TABLE 17C.111.205-3 DEVELOPMENT STANDARDS FOR PROPERTIES QUALIFYING FOR DEVELOPMENT BONUS [1] [2]					
	RA	R1	R2	RMF	RHD
LOT COVERAGE					
Maximum total building coverage	N/A	80%	90%	100%	100%
PRIMARY BUILDINGS					
Floor area ratio	N/A	N/A	N/A	N/A	N/A
Maximum building footprint per primary building - lot area 7,000 sq. ft. or less	N/A	2,450 sq. ft.	2,450 sq. ft.	N/A	N/A

Maximum building footprint per primary building - lot area more than 7,000 sq. ft.	N/A	35%	35%	N/A	N/A
Notes:					
[1] Standards not addressed in this table are consistent with the general standards in Tables 17C.111.205-1 and 17C.111.205-2.					
[2] Criteria to qualify for Development Bonuses is outlined in SMC 17C.111.225.					

Section 2. That SMC Section 17C.111.420 be amended to read as follows:

Section 17C.111.420 ((Outdoor)) Open Spaces

A. Purpose.

To create pedestrian friendly, usable areas through the use of plazas, courtyards, rooftop decks, and other ((outdoors)) open spaces for the enjoyment and health of the residents.

B. ((Outdoor)) Open Spaces Implementation.

1. Minimum Required Space.

((4))a. Each multifamily development shall ((set)) provide ((a minimum of forty-eight square feet of)) the minimum ((outdoor)) open space area for each living unit in the complex, including those units occupied by the owner or building management personnel, as identified in Table 17C.111.205-2. Open spaces may be provided individually, such as by balconies, or combined into a larger common open space. ((Private outdoor spaces can count towards this outdoor common space provision.)) Developments in RMF and RHD may provide both private and common open space to meet the minimum requirement; however, each unit must provide either the full private or common open space to count towards the minimum required space. (R)

b. Residential units with a continuous pedestrian route from the building entrance to a public park within 800 ft are not required to provide more than 36 square feet of open space per unit. For purposes of this requirement, an unsignalized crossing of a minor arterial road or greater shall not be considered a continuous pedestrian route.

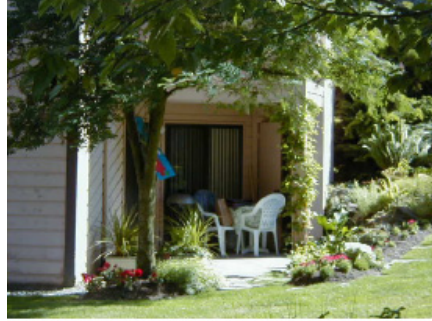

Trellis and special landscape defines private courtyard area

[NOTE: Delete graphic above]

2. ((Ground Level Units)) Private Open Space.

~~((The outdoor area for ground level units is a type of private outdoor space and must be directly accessible from the unit. The area must be surfaced with lawn, pavers, decking or sport court paving which allows the area to be used for recreational purposes. User amenities, such as tables, benches, trees, planter boxes, garden plots, drinking fountains, spas or pools, may be placed in the outdoor area. It may be covered, such as a covered patio, but it may not be fully enclosed. (R)))~~

Private open space area is typically developed for passive recreational use. Examples include balconies, patios, and private rooftop decks.



[NOTE: Delete graphic above]

- a. Private open space must be directly accessible from the unit. (R)
- b. Private open space must be surfaced with landscaping, pavers, decking, or sport court paving which allows the area to be used for recreational purposes. (R)
- c. Private open space may be covered, such as a covered balcony, but may not be fully enclosed. (R)
- d. Berms, low walls, fences, hedges and/or landscaping shall be used to define private open spaces such as yards, decks, terraces, and

patios from each other and from the street right-of-way. The material or plantings between private open spaces shall be a maximum of four feet in height and visually permeable, such as open rails, ironwork, or trellis treatment to encourage interaction between neighbors. Material or plantings between units and right-of-way shall meet applicable fencing restrictions. (P)

3. ~~((Upper Level Units))~~ Common Open Space.

~~((Upper level units are a type of private outdoor space. For upper level units, the required outdoor area may be provided individually, such as by balconies, or combined into a larger area. If combined into a larger area, it must comply with the following requirements. (R)))~~

Common open space area may be developed for active or passive recreational use. Examples include play areas, plazas, rooftop patios, picnic areas, fitness centers, pools, tennis courts, and open recreational facilities.

- a. ~~The total amount of required ((outdoor area for upper level units))~~ common open space is the cumulative amount of the required area per dwelling unit for ~~((individual))~~ common areas, minus any ~~((upper level))~~ units that provide individual ~~((outdoor areas))~~ open space (if provided). However, a combined required ~~((outdoor area))~~ open space must comply with the minimum area ~~((and dimension requirements for combined outdoor areas))~~ and meet ADA Standards for Accessible Design.
- b. ~~((The combined outdoor area may be developed for active or passive recreational use. Examples include play areas, plazas, rooftop patios, picnic areas, fitness centers, pools, tennis courts, and open recreational facilities. The area))~~ Common open space must be surfaced with ~~((lawn))~~ landscaping, pavers, decking, or sport court paving, which allows the area to be used for recreational purposes. ~~((User amenities, such as tables, benches, trees, planter boxes, garden plots, drinking fountains, spas or pools may be placed in the outdoor area. It may be covered, such as a covered patio, but it may not be fully enclosed.))~~ (R).
- c. Common open space may be covered, such as a covered patio, but may not be fully enclosed unless the open space is an equipped interior fitness area or furnished meeting space not reservable by individual residents. (R)
- d. Common open spaces with active uses used to meet these guidelines shall not be located within required buffer areas, if prohibited by critical area or shoreline regulations. (R)

- e. Common open spaces shall provide at least three of the following amenities to accommodate a variety of ages and activities. Amenities include: (P)
 - i. Site furnishings (benches, tables, bike racks)
 - ii. Picnic or outdoor grilling areas
 - iii. Patios, plazas, or courtyards
 - iv. Tot lots or other children's play areas
 - v. Enclosed pet areas that make up no more than fifty percent of the required common open space
 - vi. Community gardens accessible for use by residents
 - vii. Open lawn
 - viii. Play fields
 - ix. Sports courts, such as tennis or basketball courts, and pools that make up no more than fifty percent of the required common open space
 - x. Interior equipped fitness areas that make up no more than fifty percent of the required common open space

- f. If common open spaces are located adjacent to a street right-of-way, landscaping should be used to provide a buffer between outdoor spaces and the street right-of-way. (P)

~~((4. Common outdoor spaces shall provide at least three of the following amenities to accommodate a variety of ages and activities. Amenities include: (P)~~

- ~~a. Site furnishings (benches, tables, bike racks).~~
- ~~b. Picnic areas.~~
- ~~c. Patios, plazas or courtyards.~~
- ~~d. Tot lots.~~
- ~~e. Gardens.~~
- ~~f. Open lawn.~~
- ~~g. Play fields.~~

- h. Sports courts, such as tennis or basketball courts (no more than fifty percent of required outdoor common space), equipped interior fitness areas, or pools.)



[NOTE: Delete graphic above]



Basketball court provided in common outdoor area

[NOTE: Delete graphic above]

- ~~((5. Common outdoor spaces shall be easily visible and accessible to multifamily residents. (P)~~
6. ~~Berms, low walls, fences, hedges and/or landscaping shall be used to define private ((outdoor)) open spaces such as yards, decks, terraces, and patios from each other and from the street right-of-way. (P)~~
7. ~~Walls, hedges, and fences shall be used to define and ensure a sense of privacy in outdoor private spaces. The material or plantings should be a maximum of four feet (high and visually permeable, such as open rails, ironwork, or trellis treatment to encourage interaction between neighbors.) (P))~~
- ~~((8))~~4. Lighting shall be provided within ((outdoor)) open spaces to provide visual interest, as well as an additional security function. Lighting should not cause off-site glare. (R)

~~((9. If outdoor spaces are located adjacent to a street right-of-way, landscaping should be used to provide a buffer between outdoor spaces and the street right-of-way. (C)))~~



Screening by wall and planting

[NOTE: Delete graphic above]

~~((10. Common outdoor spaces with active uses used to meet these guidelines shall not be located within required buffer areas, if prohibited by critical area or shoreline regulations. (R)))~~

~~((14))~~5. ~~((Outdoor))~~ Open spaces should not be located adjacent to dumpster enclosures, loading/service areas or other ~~((incompatible uses))~~ facility and/or utility enclosures. (C)

PASSED by the City Council on _____.

Council President

Attest:

Approved as to form:

City Clerk

Assistant City Attorney

Mayor

Date

Effective Date



STAFF REPORT

PLANNING AND ECONOMIC DEVELOPMENT SERVICES DEPARTMENT

To:	City of Spokane Plan Commission
Subject:	South Logan TOD Implementation SMC Text Amendments
Staff Contact:	KayCee Downey, Planner II kdowney@spokanecity.org
Report Date:	June 19, 2024
Hearing Date:	June 26, 2024
Recommendation:	Approval

I. SUMMARY

The South Logan Transit-Oriented Development (TOD) Project will support more connectivity and livability in the South Logan area for the community, businesses, and organizations in the Logan Neighborhood through area-specific and citywide proposals. These City-initiated text amendments are proposed to update the Spokane Municipal Code (SMC) Unified Development Code to implement the focused community vision and policies recommended through the South Logan TOD Subarea Plan to encourage mixed-use, walkable places close to transit. The proposed draft code would amend SMC Sections 17A.20.160, 17C.111.205, 17C.111.230, 17C.111.420, 17C.120.220, 17C.122, 17C.122T, 17C.123, 17C.230, and 17C.300. The proposal also creates a new SMC Chapter, 17C.420. The proposed draft code has been developed by City staff with the input from various groups and public feedback. For ease and transparency, a Text Amendment Tracking Sheet has been included as **Exhibit A**. The full-text amendments can be found attached as **Exhibit B**.

II. BACKGROUND

The South Logan Transit-Oriented Development (TOD) project leverages the investment and analysis of prior work to propose citywide and area-specific text amendments to the Spokane Municipal Code.

The City Line, the six-mile, corridor-based Bus Rapid Transit line running from Browne's Addition, through Downtown and the University District to the Logan and Chief Garry Neighborhoods includes three stops in what is referred to as the South Logan Subarea. Opened in the Summer of 2023, this \$92 million investment created a premium transit service estimated to host more than 1 million rides per year. The potential to positively impact adjacent land use and redevelopment through Transit-Oriented Development, or TOD, played a central role in the City Line's development and advancement.

Building on recommendations from past assessments such as the 2014 "Economic and Land Use Impacts of the Spokane Central City Line" report and the 2016 "City Line Strategic Overlay" study, the Transit-Oriented Development (TOD) Framework Study evaluated a portion of the City Line Bus Rapid Transit project to develop a process for identifying infrastructure improvements and land use policy changes to support Transit-Oriented Development in the project area. The resulting Action Plan provides a guide for future processes for planning accessible improvements and regulatory changes to support equitable TOD along existing and future high-frequency transit corridors.

The 2021 Washington Legislature appropriated \$2.5 million for cities to facilitate Transit-Oriented Development in areas with high-capacity transit. The City of Spokane was one of 11 communities to be awarded \$250,000 in grant funds from the Transit-Oriented Development and Implementation (TODI) grant program through the Washington Department of Commerce. Using guidance from the TOD Framework Study Action Plan, the South Logan subarea was identified for the project funds.

The South Logan TOD Project kicked off in early 2022 to support more connectivity and livability in the South Logan Subarea for the community, businesses, and organizations in the Logan Neighborhood. Three City Line stations are located within the Subarea, with a mix of uses within the area including residential, commercial, and universities, as well as a mix of zones including Center and Corridor and Spokane's only pilot Form-Based Code. Throughout a 20-month planning process, which included the development and review of four project alternatives, a range of subject matter experts and community members provided input towards the Preferred Alternative, of which the [South Logan TOD Plan](#) and [Final Environmental Impact Statement \(FEIS\)](#) were based off. The Plan and FEIS were recommended for approval by the Spokane Plan Commission on December 13, 2024 and [approved through resolution](#) by City Council on January 29, 2024.

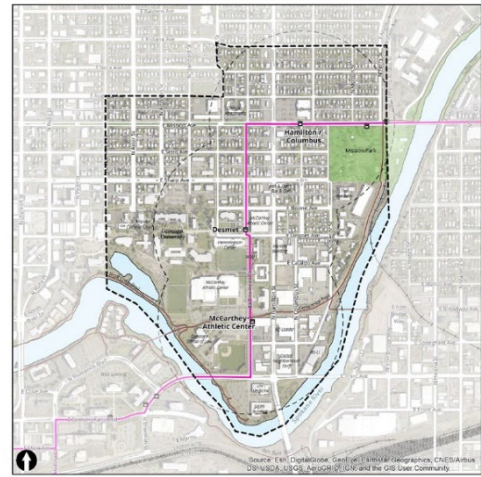

The South Logan subarea extends North to Indiana Avenue and South to the river, and includes Mission Park, Gonzaga University, and portions of Mission Avenue and Hamilton Street.

III. PROCESS

DEVELOPMENT CODE AMENDMENT PROCEDURE

Title 17 is known as the Unified Development Code (UDC) and is incorporated into the Spokane Municipal Code to implement the City's Comprehensive Plan, and by reference, the requirements of the Washington State Growth Management Act (GMA). Section [17G.025.010](#) establishes the procedure and decision criteria that the City uses to review and amend the UDC. The City may approve amendments to the UDC if it is found that a proposed amendment is consistent with the provisions of the Comprehensive Plan, and bears a substantial relation to public health, safety, welfare, and protection of the environment.

ROLE OF THE CITY PLAN COMMISSION

The proposed text amendments require a review process set forth in Section 17G.025.010(F) SMC. The Plan Commission is responsible for holding a public hearing and forwarding its findings, conclusions, and recommendations to the City Council. Utilizing the decision criteria in 17G.025 SMC, the Plan Commission may recommend approval, modification, or denial of the proposal.

The Plan Commission may incorporate the facts and findings of the staff report as the basis for its recommendation to the City Council or may modify the findings as necessary to support their final recommendation.

ROLE OF CITY COUNCIL

The City Council will also conduct a review process considering the proposed text amendments, public comments and testimony, the staff report, and the Plan Commission's recommendation. The final decision to approve, modify, or deny the proposed amendment rests with the City Council. Proposals adopted by ordinance after public hearings are official amendments to the Spokane Municipal Code.

COMMUNITY ENGAGEMENT

The proposed text amendments to the Unified Development Code (UDC) were shaped by established goals and policy recommendations, as well as direct feedback. Prior community engagement, which formed the foundation of the draft text amendments, occurred during the development of the South Logan TOD Plan and Final Environmental Impact Statement. Those efforts included a community survey, numerous virtual and in-person open houses, a three-day planning studio, and community pop up tabling, and are documented on the project webpage. Below is a list summarizing the engagement and

outreach efforts conducted exclusively for the Implementation phase of the project. Where recordings are available, external web links are provided.

Logan Neighborhood Council Meeting	February 13, 2024
Plan Commission Workshop	March 13, 2024
STA Open House – NE Community Center	March 19, 2024
STA Open House – Downtown Plaza	April 9, 2024
Plan Commission Workshop	April 10, 2024
Plan Commission Workshop	April 24, 2024
Virtual Information Session	April 30, 2024
Coffee Chat Pop Up	May 4, 2024
Expo '74 Climate Tabling	May 18, 2024
Plan Commission Workshop	May 22, 2024
Coffee Chat Pop Up	May 23, 2024
Coffee Chat Pop Up	June 1, 2024
Plan Commission Workshop	June 12, 2024

In addition to the specific engagement efforts noted above, the South Logan newsletter, project webpage, and City of Spokane social media posts were used throughout the project to inform the public on the process of South Logan TOD Implementation. A full list of South Logan newsletters can be found at my.spokanecity.org/SouthLoganTOD under Recent Updates.

SEPA REVIEW

As outlined in Section 17G.025.010 SMC, notices of proposals to amend the UDC are distributed and interested parties should be made aware of such proposals during the Plan Commission review, including the SEPA checklist and determination. Similarly, a public notice published in the *Spokesman-Review* fourteen days prior to the Plan Commission public hearing is required.

This proposal was properly noticed pursuant to Section 17G.025.010(E). See **Exhibit C** for the SEPA Determination of Non-significance issued on June 12, 2024.

COMMENTS RECEIVED

A public comment period occurred May 17, 2024 to June 17, 2024, however comments were accepted throughout the project. Any written comments received prior to 3 PM on June 19, 2024 are attached to the agenda packet for the scheduled public hearing as **Exhibit D**. All written public comments received by the Planning Department between 3 PM on June 19, 2024 to June 26, 2024 by 4:00 p.m. will be circulated to the Plan Commission prior to the public hearing scheduled at 4:00 p.m. June 26, 2024.

No comments were received prior to 3 PM on June 19, 2024.

Notice of this proposal was sent to City departments and outside agencies for their review. Department and outside agency comments are included in this report as **Exhibit E**. No Agency/City department comments were received regarding this application.

IV. ANALYSIS

PROPOSAL DESCRIPTION

The first phase of the South Logan TOD Project was the creation and adoption of the [South Logan TOD Plan](#) and [Final Environmental Impact Statement \(FEIS\)](#), which were approved by City Council on January 29, 2024. The second phase of Implementation will result in citywide and area-specific amendments to the Spokane Municipal Code, as well as land use and zone changes.

The South Logan TOD Plan includes specific policy recommendations, as well as more general directions for the form and type of envisioned development. This proposal implements the South Logan TOD Plan by amending SMC Sections 17A.020.160 “P” Definitions, 17C.111.205 Development Standards Tables, 17C.111.230 Height, 17C.111.420 Open Spaces, 17C.120.220 Height, 17C.122.070 Center and Corridor Zone Allowed Uses, 17C.122.090 Public Amenities Allowing Bonus FAR, 17C.123.010 Purpose, 17C.123.020 Code Organization, 17C.123.030 Regulating & Street Section Plans, 17C.123.040 Land Use, Height, Placement and Parking, 17C.123.050 Streetscape Requirements, 17C.123.060 Architectural Requirements, 17C.123.070 Additional Requirements, 17C.123.080 Building Type Catalogs, 17C.230.120 Maximum Required Parking Spaces, 17C.230.130 Parking Exceptions, and 17C.300.130 Development Standards.

This proposal, in large part for improved reorganization, repeals SMC Sections 17C.122.080 Floor Area Ratios (FAR), 17C.122.100 Maximum Building Height, 17C.122.110 Setbacks and Required Sidewalk Width, and Chapter 17C.122T Center and Corridor Zone Development Tables.

This proposal also creates SMC Sections 17C.122.200 Development Standards Table, 17C.122.210 Height, 17C.122.220 Height Transition, 17C.122.230 Floor Area Ratio, 17C.122.240 Setbacks, 17C.122.250 Sidewalks, and SMC Chapter 17C.420 South Logan Planned Action Ordinance.

Those amendments amount to five code amendment packages, with a summary of the amendments included as **Exhibit A** and the full drafts included as **Exhibit B**. The proposed area-specific text amendments to the Spokane Municipal Code affect development within the South Logan Project Area only, while the proposed citywide text amendments affect development citywide, including properties with Center and Corridor zoning, properties with RMF/RHD zoning, and multifamily developments.

Area-Specific Code Proposals	Citywide Code Proposals
Hamilton Form-Based Code	Center and Corridor Code
Planned Action Ordinance	Height and Height Transitions
	Multi-Unit Open Space Standards

The land use and zone changes are being proposed as a City-sponsored proposal of the 2023/2024 Comprehensive Plan Amendment docket, under [File Z24-105COMP](#). The Comprehensive Plan Amendment docket is expected to be before Plan Commission in September 2024.

PLANNED ACTION ORDINANCE

The proposed South Logan TOD Planned Action Ordinance is an area-specific text amendment, establishing a new SMC Chapter, identified in the South Logan TOD Plan as a future action.¹ Planned Actions, defined in [WAC 197-11-164](#), allow local governments to review potential impacts of development in a defined geographic area during the planning stage, rather than the development review stage. The South Logan TOD [Final Environment Impact Statement \(FEIS\)](#) approved by resolution on January 29, 2024 provides the environmental analysis and mitigation of the Preferred Alternative and serves as the foundation of the proposed Planned Action Ordinance. Any projects that fall under an adopted Planned Action Ordinance do not require additional environmental review through the State Environmental Policy Act (SEPA).

The South Logan TOD Planned Action Ordinance includes thresholds and criteria to determine what projects are covered by the existing FEIS. Historical and archaeological considerations are addressed through Inadvertent Discovery Plan and Site Inventory Form requirements. City Departments and partner agencies will receive notification of proposed projects that

¹ [South Logan TOD Plan](#), pg. 1

meet the Planned Action Ordinance Criteria. Any future development proposed under the Planned Action Ordinance shall meet all mitigation requirements as determined appropriate at time of submittal.

Future development proposals within areas subject to the Shoreline Master Program, as well as proposed drive-thrus or projects not meeting the established criteria, are not covered by the Planned Action Ordinance and must submit additional SEPA review, as necessary by state and local law.

HAMILTON FORM-BASED CODE

The Hamilton Form-Based Code (FBC) is an existing SMC Chapter, adopted in 2015 to serve as a model form-based code intended to foster an economically vibrant, walkable, mixed-use environment.² However, engagement conducted for the South Logan TOD Plan found that the current Hamilton FBC involves regulations that may create barriers to the envisioned future for the area. These potential barriers include the number of regulatory variables within a consolidated area of the city and code sections that use terms and organizational choices not found elsewhere in the SMC, which can lead to confusion. Proposed amendments to the Hamilton FBC are included in the South Logan TOD Plan Action Plan.³

The text amendment proposals include:

- Consolidating the Hamilton FBC to one implementing zone and Shopfront designations
- Increased permitted heights
- Minor design standard and street improvement modifications
- Reorganization to reflect standard SMC Chapters

CENTER AND CORRIDOR REGULATIONS

The proposed Center and Corridor text amendments primarily make permanent the current interim ordinance, with modifications, and have a citywide impact. SMC Section 17C.400.040 Pilot Center and Corridors Development Standards was adopted in July 2022, extended in December 2023, and expires June 28, 2024.⁴ The South Logan TOD Plan anticipated the continuation of the interim ordinance regulations, with all considered Alternatives including the interim ordinance as a baseline.⁵ As an interim ordinance, to make permanent there is an expectation that the regulations may need modifications to reflect feedback received during the pilot program timeline. Additionally, these proposed text amendments are also informed by relevant recommendations from the [Center and Corridor Study](#).

The targeted Center and Corridor text amendments include:

- Removing minimum parking requirements for all Center and Corridor zones
- Removing maximum FAR standards and implementing minimum FAR standards
- Replacing FAR incentives with height incentives
- Not permitting drive-thrus in CC1 zones and along Pedestrian Streets
- Increasing heights within Center types and adjusting the height transition ratio
- Reorganization to improve useability

The proposed text amendments also include proposals outside of the Center and Corridor SMC Section but are related to and/or are located within portions of SMC already being modified for the Center and Corridor specific amendments. Those proposals include:

- Removing minimum parking requirements to all Downtown zones

² [Ordinance No. C35212](#)

³ [South Logan TOD Plan](#), pg. 55

⁴ [Ordinance No. C36458](#), section 3

⁵ [South Logan TOD Plan](#), pg. 87

- Modifying Accessory Dwelling Unit standards and Residential parking requirements to reflect existing parking standards in a more clear and consistent manner, without making policy changes

HEIGHTS AND HEIGHT TRANSITIONS

The South Logan TOD Preferred Alternative calls for a height of 75-feet for a portion of the Residential High Density (RHD) zones proposed within the subarea.⁶ However, the current SMC allows for heights of 40-feet, 55-feet, 70-feet, and 150-feet, depending on location. The proposed amendments include modifying the 70-feet to be 75-feet. Of note, any zones currently zoned with a height modifier of 70-feet, e.g. RHD-70, will not be rezoned with the proposal and will still have a maximum height of 70-feet.

In addition to allowing 75-feet, the proposed amendments include increasing the permitted base height within the Residential Multifamily (RMF) and Residential High Density (RHD) zones citywide. Discussions and framing of the higher intensity residential zones anticipate a different built form within those zones when compared to the lower intensity residential zones (Residential 1, or R1, and Residential 2, or R2). However, the current base height allowances found within the Development Standards Table 17C.111.205-2 are the same for R1, R2, RMF, and RHD zones – 40-feet. A height exception does allow for an additional 15-feet of height in RMF and RHD depending on roof form standards.⁷ The proposed amendments modify the base heights in RMF and RHD to allow for the envisioned built form without requiring a rezone or other process to permit increased heights. RMF is proposed to have a maximum base height of 55-feet. RHD is proposed to have a maximum base height of 75-feet. Of note, there are portions of the South Logan TOD Preferred Alternative that calls for RMF-40 and RHD-55 zones, which would restrict those heights to 40- and 55-feet, respectively. Additionally, any properties with RMF or RHD zones with a height modifier will not be rezoned with the proposal and will have the existing maximum height limit.

In order to make more feasible the permitted base heights, the height transition requirements for higher intensity residential, commercial, and Center and Corridor development adjacent to Residential 1 (R1) and Residential 2 (R2) zones are proposed to be modified. The proposal reduces the distance of the height transition for higher intensity residential and commercial zones from 150-feet to 40-feet, after which the base height for the zone applies without transition requirements. The 150-foot transition distance was maintained for Center and Corridor zones due to their anticipated intensity. The transition ratio is also proposed to be modified, from 1:2 (one additional foot of building height for every two feet of additional horizontal distance from closest R1 and or R2 residential zone) to 2:1 (two additional feet of building height for every one foot of additional horizontal distance). Graphics illustrating the height transition can be found in the proposed text amendments in **Exhibit B**.

HIGHER INTENSITY RESIDENTIAL OPEN SPACE REGULATIONS

The South Logan TOD Plan calls for a review of residential development design standards to determine compatibility with the desired built form of the area.⁸ Residential design standards for single-unit and middle housing recently went through an extensive public engagement process as part of the [Building Opportunity for Housing](#) code amendment project. The higher intensity residential design standards are similar to those regulations, with many of the lower intensity residential design standards directly borrowed from the multi-unit code. As such, a significant modification of the design standards is not proposed at this time. A larger look at all design standards within all zones may be considered at a future date.

Feedback received from developers and various project consultants since the Building Opportunity for Housing adoption have identified a potential barrier within the existing multi-unit design standards to the envisioned built form of the higher intensity residential zones. The existing open space standards have been found to potentially cause feasibility issues for higher intensity residential zones, particularly on smaller infill lots. The proposed amendments reduce the square footage of open space per unit, for both common and private open space, from existing standards. However, of note, the proposal is at or above open space standards prior to the Building Opportunity for Housing code adoption. The proposal also incorporates different square footage requirements based on the unit type, with a studio unit requiring less open space than a three bedroom unit, and clarifies that private and common open space may both be used to meet a development's

⁶ [South Logan TOD Plan](#), pg. 42

⁷ [Spokane Municipal Code](#), 17C.111.230 Height

⁸ [South Logan TOD Plan](#), pg. 37

requirements. Adjustments to the open space standards reorganize the regulations by private and common open space, rather than ground floor and upper units, make standards more objective where necessary, and add pet areas as an allowed open space amenity.

IMPLEMENTATION OF COMPREHENSIVE PLAN GOALS AND POLICIES

Section [17G.025.010](#) SMC establishes the review criteria for text amendments to the Unified Development Code. In order to approve a text amendment, City Council shall consider the findings and recommendations of the Plan Commission along with the approval criteria outlined in the Code. The applicable criteria are shown below in *bold and italic* with staff analysis following the list. Review of the Comprehensive Plan goals and policies indicates that the proposal meets the approval criteria for internal consistency set forth in SMC 17G.025.010(G). Excerpts of the applicable goals and policies, and their Comprehensive Plan discussion points, are contained in **Exhibit F**.

17G.025.010(G) APPROVAL CRITERIA

1. **The proposed amendment is consistent with the applicable provisions of the Comprehensive Plan.**

Chapter 3: Land Use – Goal 1 – Citywide Land Use, Policy LU 1.4 Higher Intensity Residential Areas

Chapter 3: Land Use – Goal 3 – Efficient Land Use, Policy LU 3.1 Coordinated and Efficient Land Use

Chapter 3: Land Use – Goal 3 – Efficient Land Use, Policy LU 3.2 Centers and Corridors

Chapter 3: Land Use – Goal 3 – Efficient Land Use, Policy 3.5 Mix of Uses in Centers

Chapter 3: Land Use – Goal 4 – Transportation, Policy LU 4.1 Land Use and Transportation

Chapter 3: Land Use – Goal 4 – Transportation Policy LU 4.6 Transit-Supported Development

Chapter 3: Land Use – Goal 5 – Development Character, Policy LU 5.1 Built and Natural Environment

Chapter 3: Land Use – Goal 5 – Development Character, Policy LU 5.5 Complementary Development

Chapter 6: Housing – Goal H1 – Housing Choice and Diversity, Policy H 1.4 Use of Existing Infrastructure

Chapter 6: Housing – Goal H1 – Housing Choice and Diversity, Policy H 1.7 Socioeconomic Integration

Chapter 6: Housing – Goal H1 – Housing Choice and Diversity, Policy H 1.11 Access to Transportation

Chapter 8: Urban Design and Historic Preservation – Goal DP 1 – Pride and Identity, Policy DP 1.2 New Development in Established Neighborhoods

Chapter 8: Urban Design and Historic Preservation – Goal DP 2 – Urban Design, Policy DP 2.2. Design Guidelines and Regulations

Chapter 8: Urban Design and Historic Preservation – Goal DP 2 – Urban Design, Policy DP 2.6 Building and Site Design

Chapter 8: Urban Design and Historic Preservation – Goal DP 2 – Urban Design, Policy DP 2.7 Historic District and Sub-Area Design Guidelines

Chapter 8: Urban Design and Historic Preservation – Goal DP 2 – Urban Design, Policy DP 2.12 Infill Development

Chapter 8: Urban Design and Historic Preservation – Goal DP 2 – Urban Design, Policy 2.13 Parking Facilities Design

Chapter 11: Neighborhoods – Goal N 4 – Traffic Circulation, Policy N 4.7 Pedestrian Design

2. **The proposed amendment bears a substantial relation to public health, safety, welfare, and protection of the environment.**

Staff Analysis: The proposed amendments bear a substantial relation to public health, safety, welfare, and the protection of the environment. Leveraging recent investment in the City Line Bus Rapid Transit by Spokane Transit Authority, the amendments implement and support the South Logan TOD Plan, with citywide and area-specific development implications that support transit-oriented development and infill development near existing infrastructure. The proposed text amendments are derived from stakeholder and community engagement during the development of the South Logan TOD Plan and Final Environmental Impact Statement, as well as during text amendment development and revisions, allowing staff to identify and address concerns or additional barriers to ensure successful implementation of the proposed regulations. As stated above, these changes are consistent with the Comprehensive Plan and statutes protecting public health, safety, and the environment.

V. DISCUSSION

The proposed text amendments are intended to support the transit-oriented development envisioned by the South Logan TOD Plan and make feasible infill and pedestrian supportive development throughout Spokane.

Adopted January 29, 2024, the South Logan TOD Plan and Final Environmental Impact Statement created the framework for future development, leveraging the proximity of the City Line Bus Rapid Transit investment through the subarea. The proposed text amendments are intended to implement the specific recommendations as well as overall vision for the South Logan Subarea approved in the Plan. Citywide changes, as necessary to implement the South Logan TOD Plan recommendations in a consistent and efficient manner, support transit-oriented and Center and Corridor development throughout Spokane. In order to accommodate anticipated future development in the South Logan Subarea and citywide, the proposed text amendments were developed following community feedback and local best practices.

VI. CONCLUSION

Based on the facts and findings presented herein, staff concludes that the proposed text amendments to the Unified Development Code satisfy the applicable criteria for approval as set forth in SMC Section 17G.025.010. To comply with RCW 36.70A.370 the proposed text amendments have been evaluated to ensure proposed changes do not result in unconstitutional takings of private property.

VII. STAFF RECOMMENDATION

Following the close of public testimony and deliberation regarding conclusions with respect to the review criteria and decision criteria detailed in SMC 17G.025.010, Plan Commission will need to make a recommendation to City Council for approval or denial of the requested code amendments to the Unified Development Code.

Staff **recommends approval** of the proposed text amendments and recommends that the Plan Commission adopt the facts and findings of the staff report.

VIII. LIST OF EXHIBITS

- A. Text Amendment Tracking Sheet
- B. Proposed Draft Text Amendments
- C. SEPA Determination of Non-Significance
- D. Public Comments
- E. Agency Comments
- F. Comprehensive Plan Goals and Policies

EXHIBIT A

South Logan TOD Implementation

Proposed Text Amendment Tracker



The text amendment tracking sheet provides a summary of proposed changes in each section of the Spokane Municipal Code. The text amendment tracking sheet does not replace reviewing the draft code text amendments as there may be additional details and/or minor changes that were not captured in this document.

Existing SMC Section	New SMC Section	Description of Change
SMC 17A.20.160 “P” Definitions		
Section 17A.20.160 “P” Definitions		<ul style="list-style-type: none"> ○ Added “PAO Responsible Official” to the definitions ○ Added “Planned Action” to the definitions
SMC 17C.111.205 Development Standards Tables		
Section 17C.111.205 Development Standards Tables Table 17C.111.205-2 Building and Siting Standards		<ul style="list-style-type: none"> ○ Increased standard height in RMF to 55-feet from 40-feet ○ Increased standard height in RHD to 75-feet from 40-feet ○ Reduced open space requirements in RMF and RHD depending on unit size, with the minimum being 48 sq. ft. per unit. Prior to housing code changes passed in January 2024, the minimum open space required was 48 sq. ft. ○ Reduced open space requirements in RHD for sites 20,000 sq. ft. or less, allowing a minimum of 36 sq. ft. ○ Added residential units with a continuous pedestrian route to a public park within 200 feet to have a maximum open space requirement per unit of 48 sq. ft.

SMC 17C.111.230 Height

Section 17C.111.230 Height		<ul style="list-style-type: none">○ Replaced the permitted height of 70-feet to 75-feet, allowing for the increased height envisioned for podium development○ Properties currently zoned -70 will not increase to 75-feet with this amendment; a rezone of the property would be required○ Changed the transition adjacent to R1 and R2 from 1:2 to 2:1, reducing the slope to make the permitted height feasible in the more intense zones○ Increased starting height from 30-feet to 40-feet○ Removed height exception of an extra 15-feet for RMF/RHD zones with a maximum height of 40-feet; unnecessary with base height increase proposed in SMC 17C.111.205
----------------------------	--	--

SMC 17C.111.420 Open Spaces

(section name changed from Outdoor Spaces)

Section 17C.111.410 Outdoor Spaces	Section 17C.111.410 Open Spaces	<ul style="list-style-type: none">○ Rename outdoor spaces to open spaces to more accurately reflect spaces already permitted to meet minimums○ Reorganized open space standards by private and common space, rather than ground floor and upper floor space○ Emphasized that open space must be useable and accessible to residents of the development○ Add enclosed pet areas, children’s play areas, and community gardens as permitted common open space amenities○ Removed unnecessary and non-descriptive photographs found in the code
---------------------------------------	------------------------------------	--

SMC 17C.120.220 Height

Section 17C.120.220 Height		<ul style="list-style-type: none"> ○ Replaced the permitted height of 70-feet to 75-feet, allowing for the increased height envisioned for podium development ○ Properties currently zoned -70 will not increase to 75-feet with this amendment; a rezone of the property would be required ○ Changed the transition adjacent to R1 and R2 from 1:2 to 2:1, reducing the slope to make the permitted height feasible in the more intense zones ○ Increased starting height from 30 ft to 40ft
SMC 17C.122 Center and Corridor Zones		
Section 17C.122.070 Center and Corridor Zone Allowed Uses		<ul style="list-style-type: none"> ○ Amended to not allow drive-through businesses in CC1 ○ Drive-through businesses still allowed in CC2 and CC3 except for along designated pedestrian streets ○ Removed unnecessary footnote language
Section 17C.122.080 Floor Area Ratios (FAR)		<ul style="list-style-type: none"> ○ REPEALED ○ Floor Area Ratio (FAR) standards relocated to 17C.122.230
Section 17C.122.090 Public Amenities Allowing Bonus FAR	Section 17C.120.090 Public Amenities Allowing Bonus Height	<ul style="list-style-type: none"> ○ Modified to allow bonus height instead of FAR ○ Allows for 15 feet of additional height if all parking is within an entirely below-grade structure, behind the building, or in an above-ground parking garage; or if at least 20% of the residential units are Affordable; or if public art of 1% of development costs is provided ○ Removed other bonus incentives for public spaces and public art
Section 17C.122.100 Maximum Building Height		<ul style="list-style-type: none"> ○ REPEALED ○ Height standards relocated to 17C.122.210
Section 17C.122.110 Setbacks and Required Sidewalk Width		<ul style="list-style-type: none"> ○ REPEALED ○ Setbacks and sidewalk widths relocated to 17C.122.240 and 17C.122.250

	Section 17C.122.200 Development Standards Table	<ul style="list-style-type: none"> ○ NEW SECTION ○ Consolidates development standards tables ○ Increases heights in NC, DC, and EC from 40ft/55ft/150ft to 55ft/75ft/150ft ○ Removes maximum FAR standards ○ Includes minimum FAR standards in District Centers and Employment Centers
	Section 17C.122.210 Height	<ul style="list-style-type: none"> ○ NEW SECTION ○ Height standards relocated from 17C.122.210 ○ Clarifies how height is measured for code consistency
	Section 17C.122.220 Height Transition	<ul style="list-style-type: none"> ○ NEW SECTION ○ Height Transition standards relocated from 17C.122.100 ○ Changed the transition adjacent to R1 and R2 from 1:2 to 2:1, reducing the slope to make the permitted height feasible in the more intense zones ○ Increased starting height from 30 ft to 40ft
	Section 17C.122.230 Floor Area Ratio	<ul style="list-style-type: none"> ○ NEW SECTION ○ Floor Area Ratio (FAR) standards relocated from 17C.122.070 ○ Explains how FAR is measured.
	Section 17C.122.240 Setbacks	<ul style="list-style-type: none"> ○ NEW SECTION ○ Setback standards relocated from 17C.122.110
	Section 17C.122.250 Sidewalks	<ul style="list-style-type: none"> ○ NEW SECTION ○ Sidewalk standards relocated from 17C.122.110

SMC 17C.122T Center and Corridor Zone Development Tables

Chapter 17C.122T Center and Corridor Zone Development Tables		<ul style="list-style-type: none"> ○ REPEALED ○ Development tables consolidated and relocated to 17C.122.200
--	--	--

SMC 17C.123 Form Based Code Zones

Section 17C.123.010 Purpose		<ul style="list-style-type: none"> ○ Minor language updates to reflect the Transit-Oriented Development (TOD) emphasis of the South Logan area
-----------------------------	--	---

Section 17C.123.020 Code Organization	17C.123.020 Context Area and Shopfront Designations	<ul style="list-style-type: none"> ○ Reorganization of regulations found in 17C.123.030 ○ Consolidation of the four Context Areas in the Hamilton Form-Based Code to one Context Area ○ Removal of Street Types for less variable development patterns; replaced with Shopfront designations for high interest street corners
Section 17C.123.030 Regulating & Street Section Plans	17C.123.030 Building Form	<ul style="list-style-type: none"> ○ Reorganization of regulations found in 17C.123.040 ○ Created Table 17C.123.030-1 to better illustrate development regulations outside of graphics ○ Implemented maximum setback in place of build-to lines for code consistency ○ Established exception to maximum setback for public plazas
Section 17C.123.040 Land Use, Height, Placement and Parking	Section 17C.123.040 Permitted Uses	<ul style="list-style-type: none"> ○ NEW SECTION ○ Changed from a list of prohibited uses to a table of permitted uses to reflect standard organization of code and assist in the implementation and transparency of the Hamilton Form-Based Code
Section 17C.123.050 Streetscape Requirements	Section 17C.123.050 Parking and Pedestrian Connectivity	<ul style="list-style-type: none"> ○ Reorganization of regulations found in 17C.123.040
Section 17C.123.060 Architectural Requirements	Section 17C.123.060 Streetscape Requirements	<ul style="list-style-type: none"> ○ Reorganization of regulations found in 17C.123.050 ○ Consolidated regulations to one Context Area and the Shopfront Designation
Section 17C.123.070 Additional Requirements	Section 17C.123.070 Design Standards	<ul style="list-style-type: none"> ○ Reorganization of regulations found in 17C.123.050 ○ Made some regulations more objective by providing specific guidance meeting the intent of the design standard ○ Incorporated guidelines consistent with the South Logan TOD Subarea Plan
Section 17C.123.080 Building Type Catalogs	17C.123.080 Additional Requirements	<ul style="list-style-type: none"> ○ Removed the visual character catalogs as they did not fully encapsulate the permitted designs

		<p>within the Hamilton Form-Based Code and did not include enforceable regulations</p> <ul style="list-style-type: none"> ○ Reorganization of regulations found in 17C.123.070 ○ Removed allowance of barbed wire within the Hamilton Form-Based Code ○ Permitted accessory outdoor sales so long as the Clear Pedestrian Zone and Buffer Zones are maintained
SMC 17C.230 Parking and Loading		
Section 17C.230.120 Maximum Required Parking Spaces		<ul style="list-style-type: none"> ○ Modified CC parking standards, removing minimum parking requirements but keeping maximum parking standards
Section 17C.230.130 Parking Exceptions		<ul style="list-style-type: none"> ○ Text changes aligning with the modified parking table in 17C.230.120 ○ Remove minimum parking in Center and Corridor, Downtown, and Form Based Code zones ○ Changes to make clear when and where parking requirements apply to residential units and Accessory Dwelling Units for improved code useability
SMC 17C.300 Accessory Dwelling Units		
Section 17C.300.130 Development Standards		<ul style="list-style-type: none"> ○ Text changes to align with 17C.230.130 Parking Exceptions ○ Proposed change made for code consistency
SMC 17C.420 South Logan Planned Action Ordinance		
<i>(please note, the chapter number may change before adoption)</i>		
	Section 17C.420.010 Purpose	<ul style="list-style-type: none"> ○ NEW SECTION ○ Identifies the purpose of the South Logan TOD Planned Action Ordinance
	Section 17C.420.015 Procedures and Criteria for Evaluating and Determining Projects as Planned Action	<ul style="list-style-type: none"> ○ NEW SECTION ○ Identifies the Planned Action Area ○ Identifies the South Logan TOD Final EIS as the regulating environmental analysis for the Planned Action Ordinance

		<ul style="list-style-type: none"> ○ Identifies thresholds and criteria to qualify for the Planned Action Ordinance ○ Reinforces the requirement of an Inadvertent Discovery Plan and the process for Historic properties ○ Exempts projects subject to the Shoreline Master Program from qualifying ○ Exempts drive thru facilities from qualifying
	Section 17C.420.020 Planned Action Permit Process and Application	<ul style="list-style-type: none"> ○ NEW SECTION ○ Identifies the permit and application process for the Planned Action Ordinance
	Section 17C.420.025 Monitoring and Review	<ul style="list-style-type: none"> ○ NEW SECTION ○ Establishes a mandate for the City to monitor the progress of development in the Planned Action area and to review the state of the Planned Action Ordinance no later than 5 years from the effective date

EXHIBIT B

17C.420* SOUTH LOGAN TOD PLANNED ACTION ORDINANCE

The proposed South Logan TOD Planned Action Ordinance is an area-specific Spokane Municipal Code Text Amendment that will apply to new development covered by the [South Logan Final Environmental Impact Statement \(FEIS\)](#). Projects that meet the threshold criteria found within the Planned Action Ordinance and comply with any required mitigation as identified in the FEIS are exempt from additional State Environmental Policy Act (SEPA) application and review.

The Planned Action Ordinance is a new code chapter, with no pre-existing language. The proposal also includes the addition of two definitions, in Section 2. Underlined text represents the proposed additions. Text without an underline in Section 2 is existing and not proposed to be modified.

Section 1. That there is adopted Chapter 17C.420 SMC to read as follows:

Chapter 17C.420 South Logan TOD Planned Action 17C.420.010 Purpose

The purposes of this chapter are to:

- A. Designate the South Logan TOD Subarea shown in Figure 17C.420.015-A of this Chapter as a Planned Action Area for purposes of environmental review and permitting of designated Planned Action projects pursuant to RCW.43.21C.440;
- B. Combine environmental analysis, land use plans, development regulations, and City codes and ordinances together with the mitigation measures in the South Logan TOD Final Environmental Impact Statement (FEIS) to mitigate environmental impacts and process Planned Action development applications in the Planned Action Area;
- C. Confirm that the South Logan TOD FEIS meets the requirements of a Planned Action FEIS pursuant to SEPA;
- D. Establish criteria and procedures for the designation of certain projects within the Planned Action Area as Planned Action projects consistent with RCW 43.21C.440;
- E. Provide clear definition as to what constitutes a Planned Action project within the Planned Action Area, identify the criteria for Planned Action project approval, and determine how development project applications that qualify as Planned Action projects will be processed by the City;
- F. Streamline and expediate the land use permit review process by relying on the South Logan TOD FEIS; and

* Please note, the chapter number may change before adoption

- G. Apply the mitigation framework contained in this Ordinance for the processing of Planned Action project applications and incorporate the applicable mitigation measures into the underlying project permit conditions in order to address the impacts of future development contemplated by this Ordinance.

17C.420.015 Procedures and Criteria for Evaluating and Determining Projects as Planned Actions

To qualify for a Planned Action designation, a project application shall comply with the following procedures and criteria for evaluation.

- A. Planned Action Area.

The Planned Action designation shall apply to the approximately 342-acre South Logan TOD area, which is generally bounded by E Augusta Avenue and E Indiana Avenue on the north, N Perry Street and the Spokane River on the east, N Lidgerwood Street on the west, and the Spokane River on the south, and that is specifically shown in Figure 17C.420.015-A, “Planned Action Area.”

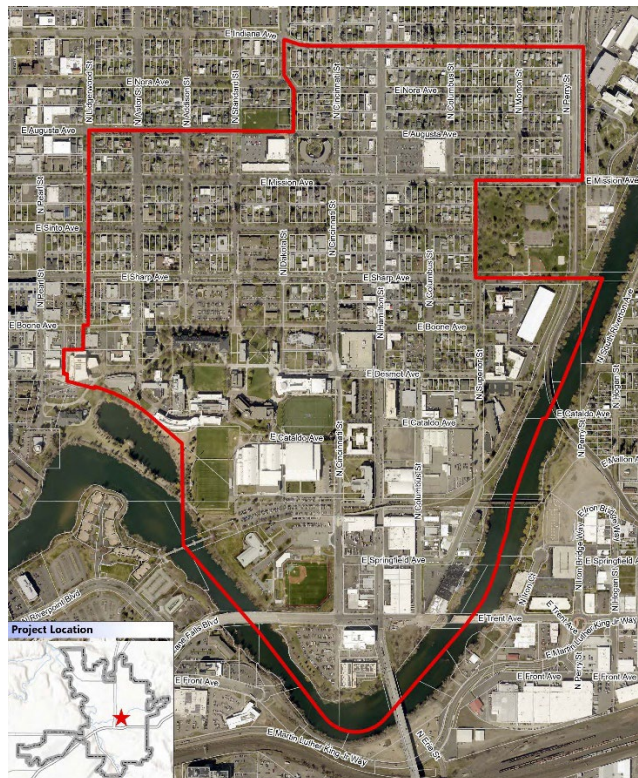

Figure 17C.420.015-A: Map of Planned Action Area

- B. Environmental Document.

* Please note, the chapter number may change before adoption

A Planned Action determination for a site-specific implementing project application shall be based on the environmental analysis contained in the South Logan TOD Final EIS adopted by the City on January 29, 2024 (RES 2024-0015), which adequately identified and addressed environmental impacts of the Planned Action. The mitigation measures contained in the FEIS, [Exhibit A](#), are based upon the findings of the South Logan TOD EIS and shall, along with adopted City regulations, provide the framework that the City will use to review and to impose appropriate conditions on qualifying Planned Action projects.

C. Planned Action Projects Designation.

Land uses and activities described in the South Logan TOD FEIS, subject to the thresholds described in subsection D of this section and the mitigation measures contained in [Exhibit A](#), are designated Planned Actions or Planned Action projects pursuant to [RCW 43.21C.440](#) and [WAC 197-11-172](#) (“Planned Action Project”). A development application for a site-specific Planned Action project located within the South Logan TOD Planned Action area that meets the criteria set forth in subsection D of this section and applicable laws, codes, development regulations and standards, may be designated a Planned Action Project pursuant to the process in SMC Section 17C.420.020.

D. Planned Action Qualifications.

The following thresholds shall be used to determine if a site-specific development proposed within the South Logan TOD Planned Action area qualifies as a Planned Action Project and has had its environmental impacts evaluated in the South Logan TOD FEIS:

1. Qualifying Uses.

a. Planned Action Categories.

The primary land uses and levels of development as envisioned in the South Logan TOD Preferred Alternative and as reviewed in the South Logan TOD FEIS, along with conditional and accessory uses permitted in the associated zones, are considered Planned Actions. The primary uses include residential, commercial, and mixed-use development.

2. Planned Action Project Primary Uses.

* Please note, the chapter number may change before adoption

A Planned Action Project may be a single Planned Action use, or a combination of Planned Action uses within a mixed-use development. A land use can qualify as a Planned Action Project when:

- a. It is within the Planned Action Area; and
 - b. It complies with the land use plan map designation of the property identified in the South Logan TOD Preferred Alternative or has a lower intensity designation; and
 - c. Is within one or more of the primary uses described in Subsection D.1 above; or
 - d. It is a permitted accessory use or appurtenant to a permitted use.
3. Public Services.

The following public services, infrastructure, and utilities may also qualify as Planned Action Projects: streets and non-motorized improvements, utilities, parks, trails, civic, cultural, governmental, and similar facilities developed consistent with the South Logan TOD FEIS mitigation measures, City design standards, critical area regulations, and the Spokane Municipal Code.

4. Development Thresholds.
- a. The following amount of increase in housing is contemplated by the Planned Action:

Increase in New Housing Units ¹	2,954
Associated Population Increase	6,735

¹ Includes equivalent housing added in college dormitories.

- b. If future development proposals in the South Logan TOD Planned Action area exceed the development thresholds specified in this chapter, further environmental review may be required pursuant to [WAC 197-11-172](#). Further, if the proposed development would alter the assumptions and analysis in the South Logan TOD FEIS, further environmental review may be required.
5. Building Heights.

* Please note, the chapter number may change before adoption

Building heights shall not exceed the maximums identified and reviewed in the South Logan TOD Final FEIS and South Logan TOD Plan.

6. Transportation.

- a. The Preferred Alternative is anticipated to generate approximately 928 new PM peak-hour vehicle trips. This equates to approximately 9 percent higher traffic volumes in the area compared to the 2045 No Action alternative.

- b. Trip Threshold.

Uses or activities that would exceed the forecasted trips shown above would not qualify as Planned Actions and would require additional transportation review.

- c. City Engineer Discretion.

The City Engineer or their designee shall have discretion to determine incremental and total trip generation, consistent with the Institute of Traffic Engineers (ITE) Trip Generation Manual (latest edition) or an alternative manual accepted by the City Engineer, for each project permit application proposed under this planned action.

- d. Transportation Improvements and Mitigation.

- i. On-Site and Off-Site Improvements.

The Planned Action may require on-site and off-site transportation improvements to mitigate significant adverse impacts as development occurs. These transportation improvements are identified in the South Logan TOD FEIS and South Logan TOD Plan. The City shall have the discretion to adjust the allocation of responsibility for required improvements between individual Planned Action projects based on their identified impacts.

- ii. Hamilton and Trent.

The intersection of N Hamilton Street/E Trent Avenue is forecasted to operate at LOS E during the 2045 No Action and LOS F with full development of Planned Action projects. Any

development must implement measures to restore the LOS and delay to its pre-development level of LOS E.

7. Elements of the Environment and Degree of Impacts.

A proposed project that would result in a significant change in the type or degree of impacts to any of the elements of the environment analyzed in the South Logan TOD FEIS, EIS addendum, and/or supplemental EIS, would not qualify as a Planned Action.

8. Changed Conditions.

Should environmental conditions change significantly from those analyzed in the FEIS, the City's PAO Responsible Official may determine that the Planned Action designation is no longer applicable until a supplemental environmental review is conducted.

9. Additional Mitigation Fees.

The City may adopt and apply such other fees as may be deemed necessary and appropriate to mitigate impacts to other capital facilities in the Planned Action area and to accommodate planned growth. Such fees, if adopted, shall be in addition to the fee required in subsection (D)(4)(d) of this section, and shall apply only to required improvements that are not addressed in this subsection.

10. Inadvertent Discovery Plan.

An Inadvertent Discovery Plan (IDP) should be implemented into the scope of work for all projects within the Planned Action area. The IDP should outline procedures to perform in the event of a discovery of archaeological materials or human remains. The IDP should always be kept at the project site during all project activities. If any artifacts or human remains are found upon excavation, the Tribal Historic Preservation Office (THPO), Washington State Department of Archaeology and Historic Preservation (DAHP), and Spokane Historic Preservation Office shall be immediately notified and the work in the immediate area cease.

11. Historic Preservation Design Review.

Properties individually placed on the Spokane Register of Historic Places or located within one of Spokane's designated historic districts must meet all requirements of the Spokane Historic Preservation Office, including

* Please note, the chapter number may change before adoption

obtaining a Certificate of Appropriateness from the Spokane Historic Landmarks Commission or the Historic Preservation Officer for proposed changes or additions to historic structures when necessary.

12. Demolitions.

Buildings fifty years of age or greater at time of demolition permit submittal shall provide a Level 2 Site Inventory Form unless determined by the Historic Preservation Officer and Planning Director to not be of historic significance.

13. Shoreline Master Program.

Areas within the Planned Action area subject to the Shoreline Master Program are not exempt from permitting or SEPA review through the FEIS and must comply with Chapter 17E.060 SMC Shoreline Regulations.

14. Uses.

Drive-thru facilities, including accessory drive-thru features, are not exempt from SEPA review and do not qualify as Planned Action Projects.

E. Planned Action Review Criteria.

1. The City's PAO Responsible Official may designate as "Planned Actions," pursuant to RCW 43.21C.030, applications that meet all of the following conditions:

- a. The proposal is located within the Planned Action Area identified in SMC 17C.420.015, or is an off-site improvement directly related to the proposed development within the Planned Action Area; and
- b. The proposed uses and activities are consistent with those described in the FEIS and subsection D of this section; and
- c. The proposal is within the Planned Action thresholds and other criteria of subsection D of this section; and
- d. The proposal is consistent with the City of Spokane Comprehensive Plan and the South Logan TOD Plan; and
- e. The proposal's significant adverse environmental impacts have been identified in the South Logan TOD FEIS; and

* Please note, the chapter number may change before adoption

- f. The proposal's significant impacts have been mitigated by the application of measures identified in Exhibit A, and other applicable City regulations, together with any modifications or variances or special permits that may be required; and
 - g. The proposal complies with all applicable local, state, and/or federal laws and regulations, and the PAO Responsible Official determines that these constitute adequate mitigation; and
 - h. Adequate infrastructure improvements are in place, or will be in place at completion of the project, to support the development of the project; and
 - i. The proposal is not an essential public facility as defined by RCW 36.70A.200, unless the essential public facility is part of or accessory to a residential, office, school, commercial, recreational, or service that is designated as a Planned Action.
2. The City shall base its decision on designation as a Planned Action project on review of a Planned Action checklist, or an alternative form developed consistent with applicable provisions of Chapter 43.21C RCW, and review of the application and supporting documentation.
 3. A proposal that meets the criteria of this section shall be considered to qualify and be designated as a Planned Action, consistent with the requirements of RCW 43.21C.440, WAC 197-11-164 et seq., and this chapter.

F. Effect of Planned Action.

1. Designation as a Planned Action project means that a qualifying proposal has been reviewed in accordance with this chapter and found to be consistent with its development parameters and thresholds, and with the environmental analysis contained in the South Logan TOD FEIS.
2. Upon determination by the City's PAO Responsible Official that the proposal meets the criteria of section (D) of this section and qualifies as a Planned Action, the proposal shall not require a SEPA threshold determination, preparation of an EIS, or be subject to further review pursuant to SEPA.

17C.420.020 Planned Action Permit Process and Application

Applications for Planned Actions shall be reviewed pursuant to the following process:

* Please note, the chapter number may change before adoption

- A. Applications shall be made on forms provided by the City, including an approved Planned Action Checklist, and shall meet the applicable requirements of the Spokane Municipal Code.
- B. After the City receives a complete application, the PAO Responsible Official shall determine whether the project qualifies as a Planned Action Project under this chapter.
- C. Once a project is determined to qualify as a Planned Action Project under this chapter, the City shall:
 - 1. Notify the applicant and the project shall proceed in accordance with the applicable permit review procedures; and
 - 2. Notify Spokane Tribe of Indians, Spokane Historic Preservation Office, internal City Departments, utility providers, and other partner agencies as deemed appropriate by the assigned project manager of the pending development under South Logan TOD FEIS. The notice required by this section may be combined with the public notice required or provided with the underlying permit and may take the form of the environmental checklist or other project review form. Notice provided shall not be less than 14 days.
- D. If a project does not qualify as a Planned Action under this chapter, the City shall notify the applicant. The notice shall describe the elements of the application that result in failure to qualify as a Planned Action.
 - 1. Projects that fail to qualify as Planned Actions may incorporate or otherwise use relevant elements of the South Logan TOD Plan and FEIS to meet SEPA requirements. The City may limit the scope of the SEPA review for the non-qualifying project to those issues and environmental impacts not previously addressed in the Planned Action.

17C.420.025 Monitoring and Review

- A. The City shall monitor the progress of development in the designated Planned Action area to ensure that it is consistent with the assumptions of this chapter and the South Logan TOD FEIS regarding the type and amount of development and associated impacts, and with the mitigation measures and improvements planned for the Planned Action Area.
- B. This Planned Action Ordinance shall be reviewed no later than five (5) years from its effective date to determine the continuing relevance of its assumptions and findings with respect to environmental conditions in the Planned Action area, the

* Please note, the chapter number may change before adoption

impacts of development, and required mitigation measures. Based upon this review, the City may propose amendments to this ordinance and/or may supplement or revise the South Logan TOD FEIS.

Section 2. That SMC Section 17A.20.160 is amended to read as follows:

17A.20.160 “P” Definitions

A. Painted Wall Highlights.

[See SMC 17C.240.015.](#)

B. Painted Wall Sign.

[See SMC 17C.240.015.](#)

C. PAO Responsible Official.

The Planning Director, serving in the capacity of administrative official of the lead agency.

D. Parcel.

See “Lot” ([SMC 17A.020.120](#)).

E. Parkway.

A thoroughfare designated as a collector or arterial, with a median reflecting the park-like character implied in the name - [SMC 17D.050A.040.U](#).

F. Party of Record.

Any person who has appeared at a hearing of the hearing examiner by presenting testimony or making written comment.

G. Paved Area.

1. An uncovered, hard-surfaced area or an area covered with a perforated hard surface (such as “Grasscrete”) that is able to withstand vehicular traffic or other heavy-impact uses.

2. Graveled areas are not paved areas.

H. Pedestrian Buffer Strips (PBS).

* Please note, the chapter number may change before adoption

A hard-surfaced or planted area(s) between travel or parking lanes and sidewalks, also called planting strips. PBS improves safety by separating vehicles and pedestrians and provide space for drainage, street trees and snow storage.

I. Pedestrian Path.

A continuous, unobstructed, reasonably direct route between an on-site parking lot and a Primary Building Entry designed and suitable for pedestrian use. Minimum requirements for Pedestrian Paths are listed in [Section 17C.123.040](#) of the FBC.

J. Pedestrian-Scaled Fixtures (lighting).

Pole-mounted light fixtures placed and designed to illuminate foot-traffic areas including exterior lots, pathways or sidewalks. For purposes of the HFBC, Pedestrian-Scaled Fixtures are defined by height as measured from ground to bottom of shade or bulb.

K. Pedestrian-Scaled Signs.

[See SMC 17C.240.015.](#)

L. Pedestrian Street.

1. A street designated on the official zoning map as a pedestrian street where development standards are required to promote a pedestrian friendly street. Pedestrian streets offer a pleasant and safe walking environment. Design features include minimal interruptions of the sidewalk by driveways, publicly usable site furnishing such as benches, tables, and bike racks, and visually interesting buildings close to the sidewalk.

M. Performance Guarantee.

A “financial guarantee” providing for and securing to the City the actual construction and installation of the required improvements.

N. Performance/Warranty Retainer.

A “financial guarantee” both providing for and securing to the City the actual construction and installation of such improvements, and securing to the City the successful operation of the improvements for two years after the City’s final inspection and acceptance of the improvements.

O. Permanent Erosion and Sediment Control Measures.

A combination of plants, mulch, sod, matting, erosion control blankets, and permanent structures that will provide long-term soil stabilization.

* Please note, the chapter number may change before adoption

P. Permanent Sign.

[See SMC 17C.240.015.](#)

Q. Permanent Stabilization.

See Permanent Erosion and Sediment Control Measures.

R. Permeable Sediment.

Sediment permitting the flow of water.

S. Person.

Any natural person, whether acting individually or in a representative capacity, partnership, joint venture, corporation, or other legal entity.

T. Pier.

Any platform structure, fill, or anchored device in or floating upon water bodies to provide moorage for watercraft engaged in commerce, including, but not limited to, wharves, mono-buoys, quays, ferry terminals, and fish weighing station.

U. Planned Action.

A Planned Action means one or more types of project action that:

1. Are designated Planned Actions by an ordinance or resolution; and
2. In conjunction with, or to implement, an adopted comprehensive plan or subarea plan that have had the significant impacts adequately addressed in an Environmental Impact Statement under the requirements of WAC 197-11-64; and
3. Is exempt from additional SEPA review for all elements covered under the Environmental Impact Statement of the adopted comprehensive plan or subarea plan.
4. Is defined in WAC 197-11-164.

V. Planned Capacity.

For all capital facilities, except transportation, capacity for a concurrency facility that does not exist, but for which the necessary facility construction, expansion, or modification project is contained in the current adopted City of Spokane

* Please note, the chapter number may change before adoption

comprehensive plan, capital improvement program and scheduled to be completed within six years. (RCW 36.70A.020).

W. Planned Capacity for Transportation Facilities.

Capacity for transportation facilities, including roads and transit, that does not exist, but where transportation improvements or strategies to accommodate the impacts of development are made concurrent with the development.

1. These strategies may include:
 - a. increased public transportation service,
 - b. ride sharing programs,
 - c. demand management, and
 - d. other transportation systems management strategies.
2. For transportation facilities, “concurrent with the development” shall mean that improvements or strategies are in place at the time of development, or that a financial commitment is in place to complete the improvements or strategies within six years (RCW 36.70A.070(6)(b)).

X. Planned Unit Development (PUD).

1. A planned unit development is a project permit for an overlay zone, approved by the hearing examiner, which does not fully comply with all of the development standards of the base zone in which it is located, but is approved based on superior or innovative design
2. The City may permit a variety of types, design, and arrangement of structures and enable the coordination of project characteristics with features of a particular site in a manner consistent with the public health, safety, and welfare.

Y. Plans.

Planning documents, which are developed by the various departments of the City, pertaining to the orderly development of public facilities.

Z. Planting Zone.

Area for street trees, ground cover or other plantings; typically included herein as a portion of overall sidewalk width reserved for locating permanent trees and tree grates.

* Please note, the chapter number may change before adoption

AA. Plat – Final.

A map or representation of a subdivision, showing thereon the division of a tract or parcel of land into lots, blocks, streets, alleys, or other divisions and dedications and containing all elements and requirements set forth in this chapter and chapter 58.17 RCW.

BB. Plat – Preliminary.

1. A neat and approximate drawing of a proposed subdivision showing the general layout of streets, alleys, lots, blocks, and other elements of a subdivision required by this chapter and chapter 58.17 RCW.
2. The preliminary plat shall be the basis for the approval or disapproval of the general layout of a subdivision.

CC. Plaza.

Areas generally open to the public on a controlled basis and used for passive recreational activities and relaxation.

Plazas are paved areas typically provided with amenities, such as seating, drinking, and ornamental fountains, art, trees, and landscaping, for use by pedestrians.

DD. Plinth.

The base or platform upon which a building wall or column appears to rest, helping establish pedestrian-scaled elements and aesthetically tying the building to the ground.

EE. Pollutant.

Any substance which is prohibited or limited by applicable laws or regulations, which is released or discharged in conjunction with development. Any substance that causes or contributes to violation of air, land, or water quality standards, released or discharged.

FF. Pollution.

Contamination, or other alteration of the physical, chemical, or biological properties of air, land, water or wetlands, or such discharge of any liquid, gaseous, solid, radioactive, or other substance into air, land, water, or wetlands as will or is likely to cause a nuisance or render such air, land, water, or wetlands harmful, detrimental, or injurious to the public health, safety, or welfare, or to domestic, commercial, industrial, agricultural, recreational, or other legitimate beneficial uses, or to livestock, wildlife, fish, native vegetation, or other aquatic life.

* Please note, the chapter number may change before adoption

GG. Potential Geologically Hazardous Areas.

Areas designated on maps maintained in the City's planning and economic development services department. They are classified "potential" because they have not been confirmed by field investigation nor do they necessarily include the full extent of all geologically hazardous areas within the City. The maps are intended to alert property owners, purchasers, developers, etc., to the possible existence of significant geological hazards, which may warrant further geotechnical study.

HH. Practicable Alternative.

An alternative that is available and capable of being carried out after taking into consideration cost, existing technology, and logistics in light of overall project purposes and having less impact to critical areas. It may involve using an alternative site in the general region that is available to the applicant and may feasibly be used to accomplish the project.

II. Predevelopment Meetings.

Meetings between City or agency staff and an applicant or their representatives prior to formal submission of a detailed application. They are intended to provide an overview of the regulatory requirements, application process, and procedural submission requirements.

JJ. Principal Buildings.

Where multiple buildings occupy a single lot, those buildings that are associated with the prevailing use of that site.

KK. Primary Building Entry.

Access or entrance of first rank, importance or value, visually associated with the prevailing ground-floor use of a building.

LL. Primary Building Walls.

Any exterior building wall that faces a street and contains a public entrance to the occupant's premises or tenant space. If an individual tenant space does not have a street facing wall, or does not have a street facing wall containing a public entrance, then the primary building wall for that individual tenant space is any wall containing a public entrance that faces a parking area on the site. (See Figure 1, [SMC 17C.240.130](#), Primary Building Walls)

MM. Primary Container.

* Please note, the chapter number may change before adoption

The container that is in direct contact with the material of concern during the course of normal transport, use, or storage.

NN. Primary Drainage Basin.

The basin of the stream or tributary within which a project is proposed, not including basins of major tributaries. For the purpose of this regulation the primary drainage basin of:

1. Latah Creek is not a part of the primary drainage basin of the Spokane River,
2. Marshall Creek is not a part of the primary drainage basin of Latah Creek.

OO. Primary Structure.

1. A structure or combination of structures of chief importance or function on a site. In general, the primary use of the site is carried out in a primary structure.
2. The difference between a primary and accessory structure is determined by comparing the size, placement, similarity of design, use of common building materials, and the orientation of the structures on a site.

PP. Primary Use.

1. An activity or combination of activities of chief importance on the site. One of the main purposes for which the land or structures are intended, designed or ordinarily used.
2. A site may have more than one primary use.

QQ. Principal Arterials.

A street serving major activity centers, providing a high degree of mobility and serving the longest trip demands within the urban area.

RR. Priority Habitats.

Habitat areas determined by WDFW to have unique or significant value to many species and that meet one or more of the following criteria:

1. High wildlife density.
2. High species diversity.

* Please note, the chapter number may change before adoption

3. Important wildlife breeding habitat.
4. Important wildlife seasonal ranges.
5. Important movement corridors.
6. Limited availability.
7. High vulnerability to habitat alteration.

SS. Priority Species.

A wildlife species requiring protective measures for their perpetuation due to their population status, their sensitivity to habitat alteration, and/or their recreational importance.

TT. Private Street.

Roadway which is not controlled or maintained by a public authority, and which serve two or more properties.

UU. Project Permit or Project Permit Application.

Any land use or environmental permit or license required for a project action, including, but not limited to, building permits, short plats, subdivisions, binding site plans, planned unit developments, conditional uses, shoreline substantial development permits, site plan review, permits, or approvals required by the critical area ordinance, and site specific rezones authorized by a comprehensive plan or subarea plan, but excluding the adoption or amendment of a comprehensive plan, subarea plan, or development regulations, except as otherwise specifically identified under RCW 36.70B.140.

VV. Projecting Sign.

[See SMC 17C.240.015.](#)

WW. Protected Species.

A general classification of animals by WDFW that includes all those species not classified as listed, game, fur-bearing, or non-protected. This also includes all birds not classified as game or non-protected.

XX. Proximity.

That two or more properties are either adjacent or separated by a street or alley.

* Please note, the chapter number may change before adoption

YY. Public Access.

The public's right to get to and use the City's public waters, the water/land interface and associated shoreline area. It includes physical access that is either lateral (areas paralleling the shore) or perpendicular (an easement or public corridor to the shore), and/or visual access facilitated by means such as scenic streets and overlooks, viewing towers, and other public sites or facilities.

ZZ. Public Facilities.

Any City-owned, operated, or contracted public facility or service in whole, or in part, whether existing or planned, including, but not limited to:

1. parks,
2. recreation facilities,
3. playgrounds,
4. streets,
5. transportation facilities,
6. open spaces,
7. fire facilities,
8. storm water drainage ponds, and
9. all such appurtenances and improvements.

AAA. Public Property.

Any City-owned real property, air space, or other interest in real estate, including streets, alleys, or other public rights-of-way, owned by or controlled by this municipality or any other governmental unit.

BBB. Public Way.

1. A dedicated "public way" is a tract of land:
 - a. conveyed or reserved by deed,
 - b. dedicated by plat, or

* Please note, the chapter number may change before adoption

- c. acquired by decree of court,
 - d. which has been accepted and dedicated by action of the city council to the public right-of-way and for secondary use as an easement for public utilities.
2. An “alley” is a public way, usually not exceeding sixteen feet in width, designed or intended to provide secondary access to abutting properties.

17C.123 FORM BASED CODE ZONES

The proposed amendments to the Hamilton Form-Based Code (FBC) is an area-specific Spokane Municipal Code Text Amendment that implement recommendations from the [South Logan TOD Plan](#). These changes are intended to make strategic adjustments to the existing FBC to enhance transit-oriented development opportunities, while retaining standards that ensure future development is pedestrian-oriented and contributes to the area. The proposal includes consolidating the context areas and street types within the area to improve useability and predictability, identifying Shopfront designations for targeted intensity, integrating visual regulations into standard tables and code format, and general reorganization. The reorganization of the code has resulted in large sections of the Hamilton FBC to be “repealed” and relocated, as noted in the text amendment tracking sheet.

*Text with ~~((**strikethrough**))~~ is proposed to be repealed/modified with underlined text representing proposed text. Text without a strikethrough or underline is existing and not proposed to be modified.*

Section 1. That SMC Section 17C.123.010 is amended to read as follows:

Section 17C.123.010 Purpose

~~((The form-based zoning categories implement the centers and corridors goals and policies and land use map designations of the comprehensive plan. This form-based code))~~ The Hamilton Form-Based Code (FBC) is designed to foster an economically vibrant, walkable, mixed-use environment along the Hamilton Street corridor within the boundaries of the code. This code regulates land development by setting careful and coherent controls on building form, coupled with performance-based parameters relative to building use and ~~((density))~~ intensity. ~~((This greater emphasis on physical form is intended to produce safe, attractive and enjoyable public spaces, including a healthy mix of uses.))~~ Through emphasis on physical form, the Hamilton FBC promotes connectivity and livability with safe, accessible public spaces, a healthy mix of uses, and access to transit.

~~((The FBC is a pilot program and is configured as a plug-in set of regulations, replacing existing zoning and design guidelines within the FBC Limits. This pilot program is consistent with the Logan Identify Plan. All code provisions expressed herein present development requirements unless otherwise indicated, including information preceded by the word “Guidelines.” Additional, specific City of Spokane standards may be required as referenced.))~~

Where not otherwise regulated within this Chapter, development within the Hamilton FBC area shall meet all applicable regulations of the Spokane Municipal Code.

Section 2. That SMC Section 17C.123.020 is amended to read as follows:

17C.123.020 ((~~Code Organization~~)) Context Area and Store Front Designations

~~((Using this code: Criteria for development within the code boundaries is expressed in six sections. Use of the FBC, relating to each of these sections, is described below:~~

~~A. Regulating & Street Section Plans.~~

~~Find the property of interest, noting its location relative to the “Context Areas” established by the Regulating Plan, as well as the location of any “Shopfront Streets” abutting the property. These elements direct many of the allowances provided in the FBC.~~

~~B. Height, Placement & Coverage.~~

~~Using criteria from the Regulating Plan, note the allowed maximum building heights; build-to-lines; minimum building frontages, and impervious surface coverage allowances detailed in this section.~~

~~C. Parking Criteria & Site Access.~~

~~Using criteria from the Regulating Plan and the Street Section Plan, note the various allowances regarding off-street surface parking, lot placement, lot and site lighting.~~

~~D. Streetscape Requirements.~~

~~Using type criteria from the Street Section Plan, note the basic configuration and feature specifications for sidewalks and pedestrian buffer zones within the FBC Limits.~~

~~E. Architectural Requirements.~~

~~Using criteria from the Regulating Plan, note the various façade treatments, screening, detailing and other requirements specific to the appearance and public-realm function of buildings.~~

~~F. Additional Requirements.~~

~~This section identifies additional requirement not covered by the HFBC.~~

~~G. Building Type Catalogs.~~

~~This section provides a visual catalog of desired building characteristics.))~~

The Hamilton Form-Based Code (FBC) area is regulated by a Context Area. Identified intersections are assigned Shopfront designations, which include additional requirements and allowances.

A. Context Area.

Context Area 1 (CA1) is the implementing zone of the Hamilton FBC. Figure 17C.123.010-A illustrates the location of the C1 zoning.



Figure 17C.123.010-A
Context Area Map

B. Shopfront Designations.

Shopfront designations are assigned to key intersections within the Hamilton FBC to allow for increased height and pedestrian-oriented design. Figure 17C.123.010-B illustrates the location of the Shopfront designations.



Figure 17C.123.010-B
Shopfront Designations

Section 3. That SMC Section 17C.123.030 is amended to read as follows:

17C.123.030 ((Regulating & Street Section Plans)) Building Form

~~((This section provides and describes the FBC Regulating Plan and Street Section Plan –two map illustrations showing the location and limits of various features and physical characteristics required under this code. The Regulating Plan also indicates placement and extents of “Shopfront Street” areas, triggering specific use, building placement and other requirements.~~

~~A.——Regulating Plan.~~

~~The Regulating Plan for the FBC is included here as Figure 17C.123.030-1, and provides the organizing framework for many of the requirements described herein. The Regulating Plan divides land within the code boundaries into four distinctive context areas and identifies shopfront streets, listed and described as follows:~~

- ~~1.—— CA 1: Context Area 1 provides for and supports the most intense development patterns, generally allowing greater height and building intensities than other context areas. CA-1 is intended to grow as a mixed-use center and focal point for the neighborhood and corridor, supporting significant commercial offerings, service activities, and high-density housing.~~

- ~~2. CA-2: Context Area 2 provides for and supports mid-range development intensities, allowing somewhat lesser height and building intensities than CA-1. CA-2 is intended to grow as a second-tier mixed-use center for the neighborhood and corridor, supporting commercial offerings, service activities, and high-density housing.~~
- ~~3. CA-3: Context Area 3 provides for and supports low to mid-range development intensities, allowing lesser height and building intensities than CA-1 or CA-2. CA-3 is intended to grow as a second-tier mixed-use area for the neighborhood and corridor, providing continuity along Hamilton by linking CA-1 and CA-2, while at the same time acting as a transition zone between the corridor environment and CA-4 and neighborhood areas immediately outside the HFBC Limits.~~
- ~~4. CA-4: Context Area 4 provides for and supports low to mid-range development intensities, allowing lesser height and building intensities than other context areas. CA-4 is intended to grow as a third-tier mixed-use area for the neighborhood and corridor, acting as a transition zone between the corridor environment and lower-density residential development immediately outside the FBC Limits. Though a mix of uses are allowed in CA-4, the area is envisioned as generally residential in scale and character.~~
- ~~5. Shopfront Street: provides for areas where specific uses, building placement, and other requirements apply. The shopfront street is generally applied to areas where business or retail use level with and directly along the public right-of-way is seen as critical.~~

~~B. Street Section Plan.~~

~~The Context Area Zones are complemented by the Street Section Plan which is included here as Figure 17C.123.030-2 and guides public and private development within the FBC Limits. The Street Section Plan defines four section types and describes amenities based upon the intended use, desired qualities, and community objectives. Right-of-ways shall not be vacated as the space is needed to incorporate the elements described in street designations below. Curb to property line and the sidewalk width shall not be reduced in order to allow for future Street Section elements. The four section types are listed and generally described in order of intensity, as follows:~~

- ~~1. Street Type 1 (Hamilton Street): Type 1 provides for and supports a mixed-use corridor environment (CA-1, CA-2, CA-3). Type 1 streets have wide, well-maintained sidewalks and pedestrian amenities to encourage strolling, walking, and shopping. They maintain a Planting Zone and Clear Pedestrian Zone on each side of the street.~~

2. ~~Street Type 2 (Mission Avenue): Type 2 provides for and supports a blend of mixed-use and residential environments (CA-1, CA-4). Type 2 serves existing east/west arterial needs, and includes a median with turn lanes (at Hamilton), a Planting Zone and Clear Pedestrian Zone on each side of the street.~~

3. ~~Street Type 3 (Includes Sinto, Sharp, Boone): Type 3 provides for and supports a mixed-use district environment (CA-2, CA-3, CA-4). Type 3 includes a Planting Zone and Clear Pedestrian Zone on each side of the street.~~

4. ~~Street Type 4 (Includes Augusta and Dakota): Type 4 provides for and supports an environment bridging between mixed-use and residential areas (CA-4). Type 4 includes a Planting Zone and Clear Pedestrian Zone on each side of the street.))~~



~~((Figure 17C.123.030-1 Regulating Plan for the Form Based Code))~~

[NOTE: Delete graphic above]

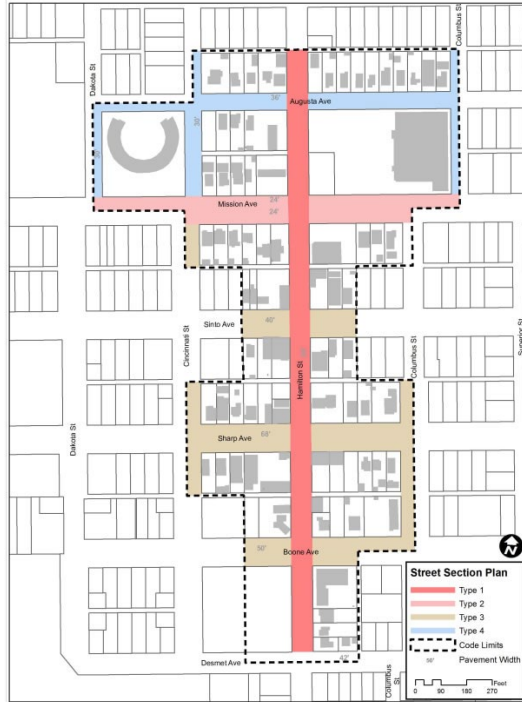

((Figure 17C.123.030-2 Street Section Plan for the Form Based Code))

[NOTE: Delete graphic above]

Within the Hamilton Form-Based Code (FBC), an emphasis is placed on building form and location in order to ensure a vibrant mixed-use environment that supports a range of transportation options, including transit, walking, and rolling.

A. Building Form Standards.

Table 17C.123.030-1 Hamilton FBC Building Form		
	<u>CA1</u>	<u>Shopfront</u>
<u>Maximum Height [1]</u>	<u>75 ft.</u>	<u>150 ft.</u>
<u>Impervious Surface Maximum</u>	<u>100%</u>	<u>100%</u>
<u>Setbacks</u>		
<u>Minimum Front Setback [2]</u>	<u>0 ft.</u>	<u>0 ft.</u>
<u>Maximum Front Setback [2] [3]</u>	<u>15 ft.</u>	<u>0 ft.</u> <u>10 ft. along Hamilton</u>
<u>Minimum Interior Side Lot Line</u>		<u>0 ft.</u>
<u>Minimum Interior Side Lot Line – adjacent to RMF or RHD</u>		<u>5 ft.</u>
<u>Minimum Rear</u>		<u>0 ft.</u>

[1] Development of 70 feet or more shall meet all applicable requirements of SMC 17C.250 Tall Building Standards.

[2] When the existing sidewalk width is less than 12 feet, structures shall be allowed no closer than 12 feet from the back of the curb.

[3] A public plaza meeting all requirements of SMC 17C.123.030C(1)(2)(i) may extend the maximum setback an additional 10 feet

B. Height.

1. Building height is the vertical distance from the average grade to the highest point of the roof or structure.

2. Height Exceptions.

a. Pitched roofs may extend above the height limit, but if the space within the pitched roof is habitable, it shall only be used for residential purposes.

b. For flat roofs, open roof structures (pergolas, arbors) and architectural roof structures (turrets, etc.) may extend beyond the height limit by no more than 12'.

c. For flat roofs, enclosed roof structures (penthouses) may extend above the height limit by no more than 18' from the roof line if set back at least 20' from all street lot lines.

C. Building Placement.

1. Shopfront Designations.

a. Building placement along Shopfront Streets shall prioritize street corner locations, precluding the development of parking, open spaces, or other lot features at street corners.

b. Exceptions.

i. Public Plaza.

A plaza or courtyard, with a minimum area of four hundred square feet or two percent of the total interior floor space of the development, whichever is greater, may be located between a building and the street corner so long as the plaza:

a. is a level space accessible to the public;

b. is at least ten feet in width;

c. is within thirty inches of the grade of the sidewalk providing access to it;

d. has no more than sixty percent of the area covered in vegetation; and

- e. includes seating, pedestrian-scale lighting, decorative paving, and other pedestrian furnishings.

Section 4. That SMC Section 17C.123.040 is amended to read as follows:

17C.123.040 ((~~Land Use, Height, Placement and Parking~~)) Permitted Uses

~~((This section provides a broad range of allowable use categories within the Regulating Plan limits, specifying permitted and prohibited uses according to building story reflecting the development patterns expressed in the Regulating Plan. This section also regulates building height, placement, frontage and impervious surface coverage, specifying each within the Context Areas provided in the Regulating Plan and managing the transition between high-intensity mixed-use areas and low-intensity residential areas outside the limits of this form-based code. This section also regulates parking, parking lot location and treatment, and site lighting, consistent with the Regulating Plan. Conformance with these standards is critical to establishing the type of pedestrian and vehicular access patterns needed for the area to thrive as a vibrant, walkable district.~~

~~A. Use Provisions.~~

~~Use regulations are provided in figures 17.123.040-D through 17.123.040-G for all areas within the Regulating Plan. Uses deemed unsuitable for areas within the Regulating Plan area are specifically identified.~~

~~B. Building Height.~~

~~The height of buildings shall be measured from mean grade to top of cornice or roof eave and shall meet the specifications provided in figures 17.123.040-D through 17.123.040G. Building height measurements express regulatory standards.~~

- ~~1. Maximum height limits in CA-1, CA-2, and CA-3 are allowed only within 100' to 114' of the Hamilton right of way line to match the platting pattern along Hamilton. Beyond 100' from Hamilton, proposals shall be designed with respect for the height, scale and character of adjacent zone as described in Figure 17C.123.040-A:))~~

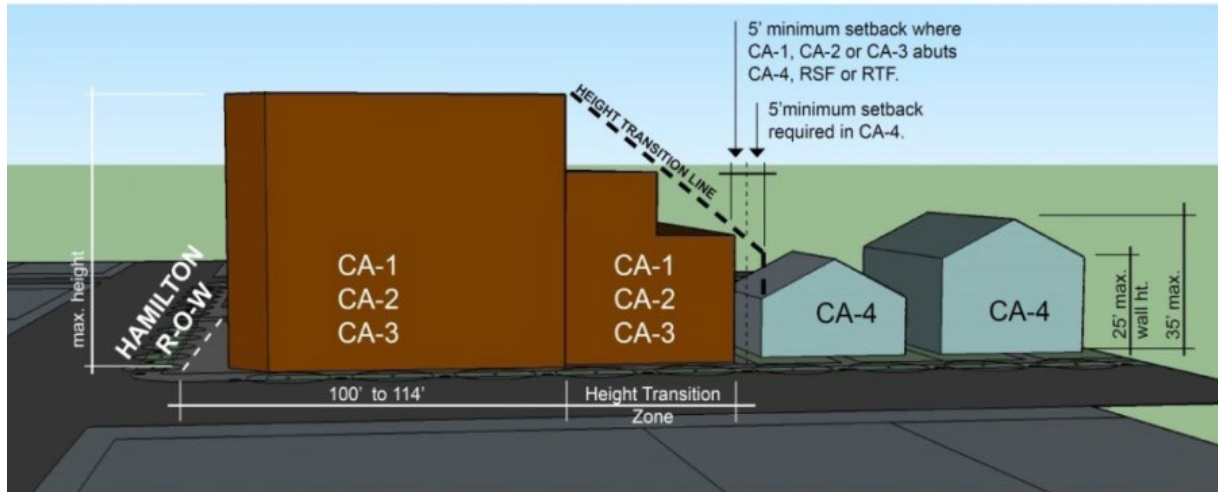

~~((Figure 17C.123.040A: The maximum height designation for CA-1, CA-2, CA-3 is allowed within 100' to 114' of the Hamilton right of way line to match the platting pattern along Hamilton. Beyond this point, the maximum height may not exceed a transition line to the maximum wall height allowed in the adjacent zone.))~~

[NOTE: Delete graphic above]

~~((C. Story listings are provided for reference purposes only, expressing typical outcomes for listed heights. Allowable height exceptions apply to the overall distance extending beyond the measured building height, as follows:~~

- ~~1. Pitched roofs may extend above the height limit, but if the space within the pitched roof is habitable, it shall only be used for residential purposes.~~
- ~~2. For flat roofs, Open Roof Structures (pergolas, arbors) and Architectural Roof Structures (turrets, etc.) may extend beyond the height limit by no more than 12'.~~
- ~~3. For flat roofs, enclosed roof structures (penthouses) may extend above the height limit by no more than 18' from the roof line if set back no less than 20'.~~

~~D. Shopfront Street Provisions.~~

~~Building placement along Shopfront Streets shall prioritize street corner locations, precluding the development of parking, open spaces or other lot features at street corners.~~

~~E. Impervious Surface Coverage.~~

~~Impervious surfaces shall not exceed the maximum impervious surface percentages (calculated on the basis of the lot) specified in Table 17C.123.040-4.))~~

((Table 17C.123.040-1 Impervious Surface Coverage				
	CA-1	CA-2	CA-3	CA-4
Maximum Impervious Surface	90%	80%	70%	50%))

~~((F.—Parking~~

- ~~1.—Off-Street Surface Parking: Off-street surface parking shall not be placed between the street right-of-way and the building fronting the street.~~
- ~~2.—Parking Space and Aisle Dimensions: Standards for parking space and aisle dimension can be found in SMC 17C.230.140.~~
- ~~3.—Bicycle Parking: Requirements for bicycle parking are found in SMC 17C.230.200. Bicycle parking provided in the streetscape can contribute to requirements in SMC 17C.230.200.~~
- ~~4.—Other Provisions: Additional parking requirements are stated in 17C.230 SMC, Parking and Loading. The FBC supersedes the location and amount requirements for parking; these standards are identified for each context area in figures 17.123.040-D through 17.123.040-G.~~

~~G.—Surface parking and site lighting.~~

~~Surface parking lot and site lighting shall contribute to the character and safety of the site and adjacent rights of way, while not disturbing adjacent properties. Surface lot and site lighting shall adhere to the following standards:—~~

- ~~1.—Lighting types — Pedestrian-scale fixtures shall be used for all lighting illuminating required Pedestrian Paths. Vehicle-scale fixtures may be used for general surface lot and site lighting. (See Figure 17C.123.040-B)~~
- ~~2.—Performance — Parking lot and site lighting shall provide adequate night visibility and security by distributing a minimum of two foot-candles to a maximum of six foot-candles of illumination at ground level. All lighting shall be shielded from producing off-site glare, directing light downward and away from adjacent properties.~~
- ~~3.—Driveways/Site Access — Driveway widths shall not exceed 24 feet, and curb cuts shall not exceed 30 feet for combined entry/exits.—~~
- ~~4.—Pedestrian Walkways — Within surface lots containing more than 30 parking stalls, pedestrian-friendly walkways shall be provided between the surface lots and building entrances. Pedestrian Paths shall be not less than five feet wide and be clearly defined, using at least two of the following:—~~
 - ~~a.—Six-inch vertical curbing~~
 - ~~b.—Textured paving, including across vehicle lanes~~

c. ~~Continuous landscaped area at a minimum of 3 feet wide on at least one side of the walkway~~

H. ~~Shopfront Street Provisions – If fronting on a Shopfront Street, above-ground parking structures shall provide continuous ground-level commercial or office spaces and uses along the street, except at ingress and egress points into the structure. (See Figure 17C.123.040-C.)~~

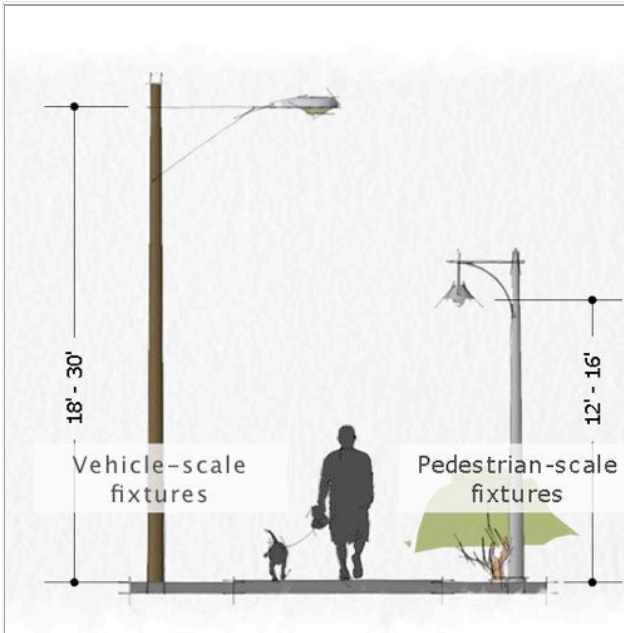

~~((Figure 17C.123.040-B: Unless otherwise specified, Vehicle-Scale and Pedestrian Scale lighting fixtures must meet height criteria illustrated here.))~~

~~[NOTE: Delete graphic above]~~

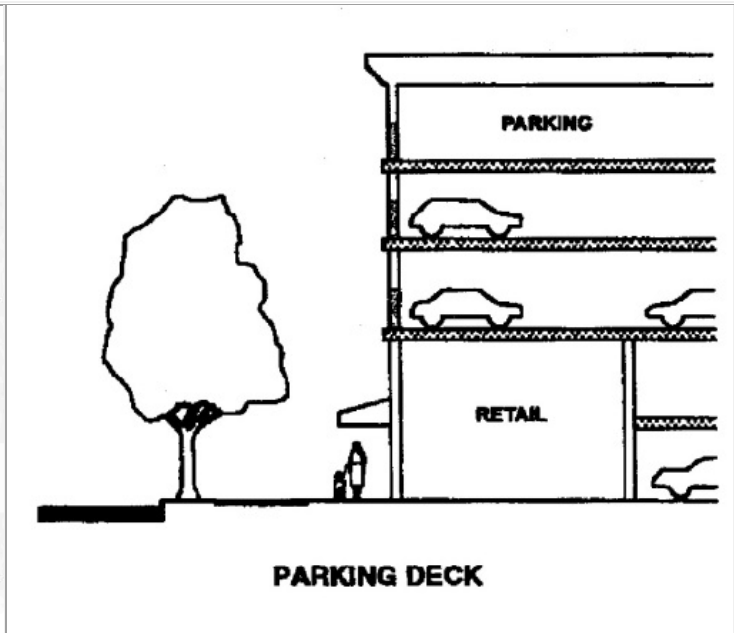

~~((Figure 17C.123.040-C: Parking garages (decks) along shopfront streets must provide ground-level retail, commercial or office space fronting the street.))~~

~~[NOTE: Delete graphic above]~~

~~((I. Regulatory Cutsheets – The information presented in the tables in figures 17.123.040-D through 17.123.040-G represent the regulations for height, parking, land uses, build-to-lines, and building frontage for all Context Areas.~~

~~J. Figure 17C.123.040-H supplements the regulatory cutsheets by providing visual representation for build-to-lines, interior lot lines and other standards.))~~

Figure 17C.123.040-D
Context Area 1 (CA-1)

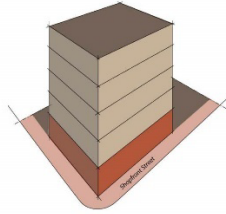

Images above are representational only and are not to be considered regulatory. The Rendering Plan, this chapter's general provisions and the information contained in the table to the right constitute the regulatory framework related to land use, height, parking, build to line, coverage and setbacks.

¹Build-to-line shall establish a 12-foot minimum and up to 22' maximum space from the back of the curb to the building along Street Type 1. If existing width is less than 12' structures shall be allowed no closer than 12' from the back of the curb.

Shoptone within 100' 114' of rear boundary line	66' (five stories)	Height max.
Beyond 100' 114' Hamilton property line	Transition Standards as identified in 17C.123.060-A	
Maximum surface parking	2 spaces/500 of floor area	Parking
Landscaping	See Section SAC 17C.200	
Location	To side or rear of building	Land uses
Additional Parking Requirements	See Sections: SAC 17C.230.100 SAC 17C.230.120 SAC 17C.230.130 SAC 17C.230.140 SAC 17C.230.200	
Residential, except where prohibited		
Non-residential all floors		
Prohibited uses		
Single-family detached and townhouses		
Minor accessory, storage or warehouse		
Adult businesses		
Residential uses on adjacent street (ground floor)		
Structural parking on shoptone (ground floor)		
Accessory uses		
Drive-through facilities		
Street Type 1	3'-6" - 12'-0"	Build-to-line
Street Type 2 and 4	0'	
When within 50' of CA-1	0'	Setback from
Street Type 3	See applicable	
Alley	0'	Building coverage from
Interior lot line	0'	
Interior lot line if abutting CA-4	0'	
Street Type 1	80%	Building coverage from
Street Type 2	60%	
Street Type 3	N/A	
Street Type 4	0%	

[NOTE: Delete graphic above]

Figure 17C.123.040-E
Context Area 2 (CA-2)

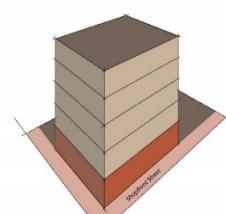

Images above are representational only and are not to be considered regulatory. The Rendering Plan, this chapter's general provisions and the information contained in the table to the right constitute the regulatory framework related to land use, height, parking, setbacks and build to line, coverage and setbacks.

¹Build-to-line shall establish a 12-foot minimum and up to 22' maximum space from the back of the curb to the building along Street Type 1. If existing width is less than 12' structures shall be allowed no closer than 12' from the back of the curb.

Shoptone within 100' 114' of rear boundary line	66' (five stories)	Height max.
Beyond 100' 114' Hamilton property line	Transition Standards as identified in 17C.123.060-A	
Maximum surface parking	2 spaces/500 of floor area	Parking
Landscaping	See Section SAC 17C.200	
Location	To side or rear of building	Land uses
Additional Parking Requirements	See Sections: SAC 17C.230.100 SAC 17C.230.120 SAC 17C.230.130 SAC 17C.230.140 SAC 17C.230.200	
Residential, except where prohibited		
Non-residential all floors		
Prohibited uses		
Single-family detached and townhouses		
Minor accessory, storage or warehouse		
Adult businesses		
Residential uses on adjacent street (ground floor)		
Structural parking on shoptone (ground floor)		
Accessory uses		
Drive-through facilities		
Street Type 1	3'-6" - 12'-0"	Build-to-line
Street Type 2	0'	
Street Type 3	0'	Setback from
When within 50' of CA-1	See applicable	
Alley	0'	Building coverage from
Interior lot line	0'	
Interior lot line if abutting CA-4	0'	
Street Type 1	80%	Building coverage from
Street Type 2	60%	
Street Type 3	N/A	
Street Type 4	N/A	

[NOTE: Delete graphic above]

Figure 17C.123.040-F
Context Area 3 (CA-3)

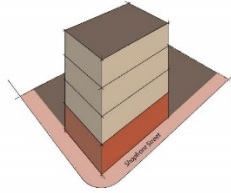

Images above are representational only and are not to be considered regulatory. The Regulatory Plan, this chapter's general provisions and the information contained in the table to the right control the regulatory framework related to land use, height, parking, setbacks, building form, coverage and formage.

¹ Build to line shall be built 1/2 foot minimum and up to 27' maximum space from the back of the curb to the building along Street Type 1. If existing width is less than 17' meters shall be allowed no closer than 1/2' from the back of the curb.

		Height max.
Shoofront of 2 to 100' - 114' of frame from property line	54' (four stories)	
Beyond 100' - 114' Shoofront	Transitions 5' maximum as identified in 17C.123.040-A	
Property Line		
Maximum surface parking	2 spaces/100 of floor area	Parking
Landscaping	Section SMC 17C.200	
Location	To side or rear of building	
Additional Parking Requirements	See Sections SMC 17C.200.100 SMC 17C.200.120 SMC 17C.200.140 SMC 17C.200.140 SMC 17C.200.150	
Residential	residential, except where goods-based	Land Uses
Non-Residential all floors		
Prohibited uses:		
	Highly toxic materials and flame retardant	
	Flammable, volatile, or combustible	
	All auto services	
	Required use of asphalt seal coat ground floor	
	Exposed parking on street front street (service floor)	
	Auto Repair Shop	
	Drive Through Facilities	
Street Type 1	None - 10' max ¹	Build to line
Street Type 2	10'	
Street Type 3, 4	0'	
Where within 10' of ADA, ADA, or RTT	0'	
Alley	0'	Setback line
Interior lot line	0'	
Interior lot line, if attached CA4, BSC, or RTT	0'	
Street Type 1	75%	Building Formage min.
Street Type 2	60%	
Street Type 3	N/A	
Street Type 4	N/A	

[NOTE: Delete graphic above]

Figure 17C.123.040-F
Context Area 4 (CA-4)

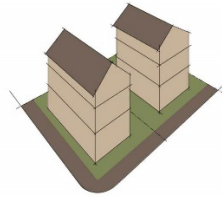

Images above are representational only and are not to be considered regulatory. The Regulatory Plan, this chapter's general provisions and the information contained in the table to the right control the regulatory framework related to land use, height, parking, setbacks, building form, coverage and formage.

¹ Attached garage or carport entrance is required to be setback twenty feet from the property line.

² See SMC 17C.110.220E(1) setbacks regarding the use of front yard averaging.

		Height max.
Roof Height	35 feet	
Wall Height	25 feet	
Minimum off-street parking	1 space/ dwelling unit	Parking
Landscaping	See Section SMC 17C.200	
Location	See Section SMC 17C.200	
Additional Parking Requirements	See Sections SMC 17C.200.100 SMC 17C.200.120 SMC 17C.200.140 SMC 17C.200.145	
Residential		Land Uses
Non-Residential (on ground floor)		
Non-Residential Development shall have a Residential Component from Residential and be no more than 1,000 of floor area		
Prohibited uses:		
	All industrial categories	
	Parking garage ramp, auto services, commercial auto, and storage, auto repair, car washing, and drive through	
	Alley	
	Auto Repair Shop	
	Drive Through Facilities	
Street Type 1	N/A	Build to line
Street Type 2	10'	
Street Type 3	14'	
Street Type 4	19'	
Alley	0'	Setback line
Interior lot line	0'	
Street Type 1	N/A	Building Formage min.
Street Type 2	60%	
Street Type 3	50%	
Street Type 4	None	

[NOTE: Delete graphic above]

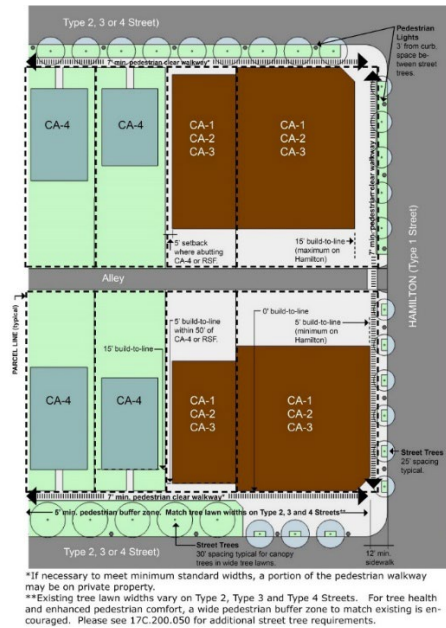

((Figure 17C.123.040-H Visual Diagram))

[NOTE: Delete graphic above]

A. Permitted Uses.

Uses permitted in the residential zones are listed in Table 17C.123.040-1 with a "P." These uses are allowed if they comply with the development standards and other standards of this chapter.

B. Limited Uses.

Uses permitted that are subject to limitations are listed in Table 17C.123.040-1 with an "L." These uses are allowed if they comply with the limitations as listed in the footnotes following the table and the development standards and other standards of this chapter. The paragraphs listed below contain the limitations and correspond with the bracketed [] footnote numbers from Table 17C.123.040-1.

C. Conditional Uses.

Uses that are allowed if approved through the conditional use review process are listed in Table 17C.123.040-1 with a "CU." These uses are allowed provided they comply with the conditional use approval criteria for that use, the development standards, and other standards of this chapter. The conditional use review process and approval criteria are stated in SMC 17C.320, Conditional Uses.

D. Uses Not Permitted.

Uses listed in Table 17C.123.040-1 with an "N" are not permitted. Existing uses in categories listed as not permitted are subject to the standards chapter 17C.210 SMC, Nonconforming Situations.

**Table 17C.123.040-1
Hamilton Form-Based Code Primary Uses**

<u>Use is:</u>	<u>CA1</u>	<u>Shopfront</u>
<u>P – Permitted</u>		
<u>N – Not Permitted</u>		
<u>L – Allowed, but special limitations</u>		
<u>CU – Conditional Use review required</u>		
<u>Residential Categories</u>		
<u>Group Living [1]</u>	<u>L/CU</u>	<u>L/CU</u>
<u>Single-Unit Residential Household Living</u>	<u>N</u>	<u>N</u>
<u>Other Residential Household Living</u>	<u>P</u>	<u>L [2]</u>
<u>Commercial Categories</u>		
<u>Adult Business</u>	<u>N</u>	<u>N</u>
<u>Commercial Outdoor Recreation</u>	<u>N</u>	<u>N</u>
<u>Commercial Parking</u>	<u>N</u>	<u>N</u>
<u>Structured Parking</u>	<u>P</u>	<u>L [3]</u>
<u>Drive-through Facility</u>	<u>N</u>	<u>N</u>
<u>Major Event Entertainment</u>	<u>P</u>	<u>N</u>
<u>Office</u>	<u>P</u>	<u>P</u>
<u>Quick Vehicle Servicing</u>	<u>N</u>	<u>N</u>
<u>Retail Sales and Service</u>	<u>P</u>	<u>P</u>
<u>Mini-storage Facilities</u>	<u>N</u>	<u>N</u>
<u>Vehicle Repair</u>	<u>N</u>	<u>N</u>
<u>Industrial Categories</u>		
<u>High Impact Uses</u>	<u>N</u>	<u>N</u>
<u>Industrial Service</u>	<u>N</u>	<u>N</u>
<u>Manufacturing and Production</u>	<u>N</u>	<u>N</u>
<u>Railroad Yards</u>	<u>N</u>	<u>N</u>
<u>Warehouse and Freight Movement</u>	<u>N</u>	<u>N</u>
<u>Waste-related</u>	<u>N</u>	<u>N</u>
<u>Wholesale Sales</u>	<u>N</u>	<u>N</u>
<u>Institutional Categories</u>		
<u>Basic Utilities</u>	<u>P</u>	<u>N</u>
<u>Colleges [4]</u>	<u>L</u>	<u>L</u>
<u>Community Service</u>	<u>P</u>	<u>P</u>
<u>Daycare</u>	<u>P</u>	<u>P</u>
<u>Medical Center</u>	<u>N</u>	<u>N</u>
<u>Parks and Open Areas</u>	<u>N</u>	<u>N</u>
<u>Religious Institutions</u>	<u>P</u>	<u>P</u>
<u>Schools</u>	<u>P</u>	<u>P</u>
<u>Other Categories</u>		
<u>Agriculture</u>	<u>N</u>	<u>N</u>
<u>Aviation and Surface Passenger Terminals</u>	<u>N</u>	<u>N</u>
<u>Detention Facilities</u>	<u>N</u>	<u>N</u>
<u>Essential Public Facilities</u>	<u>CU</u>	<u>CU</u>

<u>Mining</u>	<u>N</u>	<u>N</u>
<u>Rail Lines and Utility Corridors</u>	<u>N</u>	<u>N</u>
<u>[1] Must comply with the regulations found in SMC 17C.190.100.</u>		
<u>[2] Residential uses are not permitted on the ground floor in Shopfront designated areas.</u>		
<u>[3] Structured parking is not permitted on the ground floor in Shopfront designated areas.</u>		
<u>[4] The accessory uses of housing, retail, and offices are permitted. Lecture halls, food halls, health and sports facilities, laboratories, and other accessory uses not specifically allowed are not permitted within the Hamilton Form-Based Code. Dormitory style housing must comply with the regulations found in SMC 17C.190.100 for group living.</u>		

Section 5. That SMC Section 17C.123.050 is amended to read as follows:

Section 17C.123.050 ((~~Streetscape Requirements~~)) Parking and Pedestrian Connectivity

~~((This section identifies features and specifications for commercial and residential streets and alleys within FBC Limits, keyed to the street types identified in the Street Section Plan and to Shopfront Street areas noted on the Regulating Plan. These criteria work to establish the type of active, economically vibrant public realm sought by the community, balancing vehicular access with the safety and convenience of pedestrians and other non-motorized modes of travel.~~

~~A. — Streetscape Requirements.~~

~~Required streetscape features and dimensions of those elements are identified in Table 17C.123.050-1.))~~

((Table 17C.123.050-1 Streetscape Requirements [1]					
	Type-1	Type-2	Type-3	Type-4	Alley
Sidewalks					
Overall Width (each side)	12' to 22'	12'	12'	12'	N/A
Type	A	A	A	A	N/A
Clear Pedestrian Zone	7'	7'	7'	7'	N/A
Planting Zone (each side)	5'	5'	5'	5'	N/A
[2]					
Street Furnishings					
Lighting, types	P [3]	P[3]	P[3]	P[3]	V
Planting, types	S	S/M	S/M	S	N/A
Benches	R	R	R	N/R	N/A
Trash receptacles	R	R	R	N/R	N/A
Bicycle parking	N/R	N/R	N/R	N/R	N/A

~~[1] See City of Spokane Department of Engineering Design Standards for additional specifications.~~

~~[2] Minimum size; Existing tree lawn widths vary on Type 2, 3 and 4 Streets. Additional setbacks, if any, should match existing tree lawn widths in the CA-4 zone. Please see 17C.200 for additional street tree requirements.~~

~~[3] See Figure 17C.123.050-B (below) for Pedestrian Scale Lighting Standards
Parking Stall types: "A" = 8.5' W x 18' L parallel stalls; "B" = 9' W x 16' L angled stalls, back in (60°?)~~

~~Sidewalk types: "A" = 4' x 2' scored concrete~~

~~Lighting types: "P" = Pedestrian scale; "V" = Vehicle scale~~

~~Planting types: "S" = Street trees; "M" = Median planting~~

~~Benches, Trash receptacles, Bicycle parking: "R" = Required; "N/R" = Not required))~~

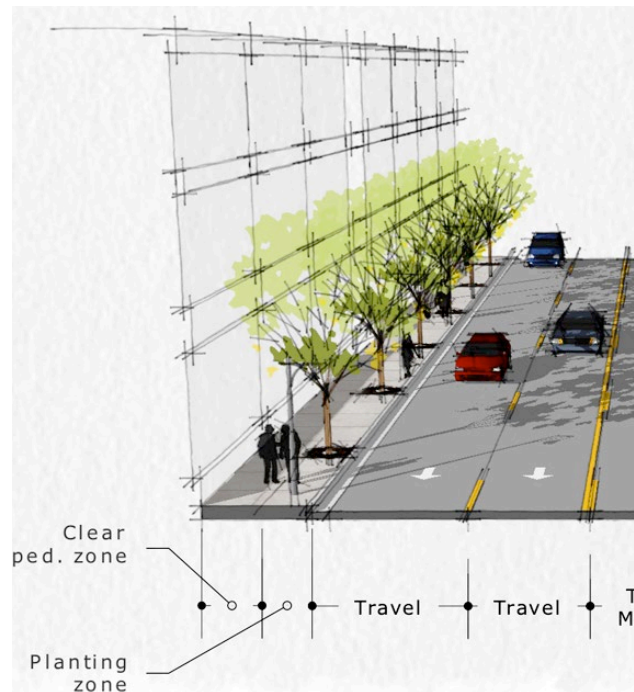

~~((Figure 17C.123.050-A—Desired Frontage Characteristics.))~~

[NOTE: Delete graphic above]

~~((A.—Sidewalks:~~

~~The composition and color of sidewalks shall be as described in Table 17C.123.050-1, and shall be continued as they cross vehicular driveways (See Figure 17C.123.050-E).~~

- ~~1. When the existing sidewalk width is less than 12 feet structures shall be allowed no closer than 12 feet from the back of the curb.~~
- ~~2. When the existing sidewalk width is greater than the bare minimum of 12 feet the sidewalk environment shall be designed to meet the intent of the Street Type designation of the street. Existing sidewalk width shall not be reduced or encroached upon by new development.~~

~~B. Street Furnishings, Placement.~~

~~Street furnishings including light poles, benches, and trash receptacles shall be placed between tree locations within the Planting Zone. Street furnishings shall not impede the clear view triangle. Temporary and intermittent sidewalk encroachments including café seating, planters, ramps, steps, and sandwich board signs may be located in the Planting Zone without restriction, or in the Clear Pedestrian Zone provided a pathway of at least six (6) feet wide remains free of such obstructions (See Figure 17C.123.050-F). Bicycle parking is encouraged where the requirement for the Planting Zone and Clear Pedestrian Zone can be met. Bicycle parking provided in the streetscape can contribute to requirements in SMC 17C.230.200(1)(b). Street furnishings required in Table 17C.123.050-1 are to be provided in all Context Areas as follows:~~

- ~~1. Planting — Street trees must be installed and maintained by the adjacent property in all streets bordering development. Generally, street trees should be spaced on average 25 feet apart. At a minimum, street trees shall provide a continuous row of City-approved trees spaced according to mature canopy size, plus one or more types of City-approved ground cover. Additional requirements for landscaping are stated in chapter 17C.200, Landscaping and Screening.~~
- ~~2. Lighting — City-approved Traditional Series pedestrian scale lighting as shown in Figure 17C.123.050-B (flower basket optional) shall be provided and spaced at an average 50 to 60 feet apart, generally midway between required street trees and centered thirty-six (36") from the curb to ensure a uniform distance from the street edge along the entire street.~~
- ~~3. City approved benches and trash receptacles shall be provided for all buildings larger than 10,000 sf. Buildings less than this size are encouraged to include such amenities.))~~

Hamilton FBC Pedestrian Light Standards

C.1. The City of Spokane Traditional Series pedestrian acorn light (flower basket optional) shall be installed at an average 25' spacing generally spaced midway between street trees and centered thirty-six inches (36") from the curb to ensure a uniform distance from street edge along the entire street.

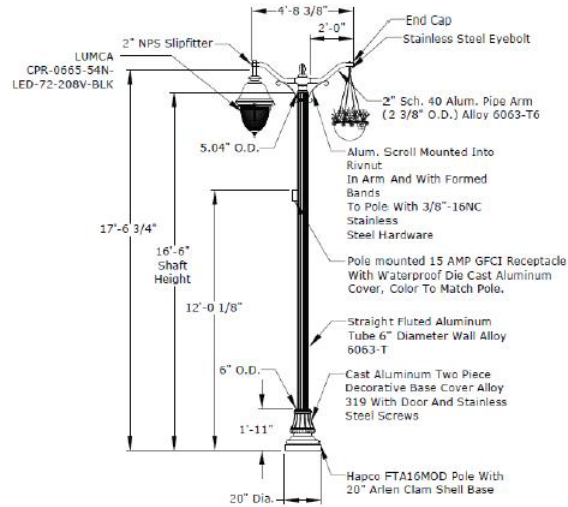

Traditional Series Light Fixture
Not to Scale

((Figure 17C.123.050-B))

[NOTE: Delete graphic above]



~~((Figure 17C.123.050-E: Curb cuts and driveways may not interrupt sidewalk material and pattern requirements. Ramps may not encroach on Clear Pedestrian Zones.))~~

[NOTE: Delete graphic above]



~~((Figure 17C.123.050-F: Temporary sidewalk encroachments are allowed in the Planting Zone, or in the Clear Pedestrian Zone as per Table 17C.123.050-4.))~~

[NOTE: Delete graphic above]

The Hamilton Form-Based Code (FBC) establishes parking standards that support pedestrian and vehicular movement within and through the area to provide a safe and convenient environment for transit, walking, biking, and rolling.

A. Dimensional standards and other off-street parking requirements are found in SMC 17C.230.200 unless otherwise modified in this chapter.

B. Minimum Parking.

For all uses within the Hamilton FBC area, there are no minimum vehicular off-street parking spaces.

C. Maximum Parking.

A maximum of 2 spaces for every 500 square feet of floor area is permitted.

D. Parking Location.

1. Off-Street Surface Parking.

a. Off-street surface parking shall not be placed between the street right-of-way and the building fronting the street.

2. Shopfront Designated Areas.

If fronting on a Shopfront designation, above-ground parking structures shall provide continuous ground level commercial or office spaces and uses along the street, except at ingress and egress points into the structure. (See Figure 17C.123.040-A).

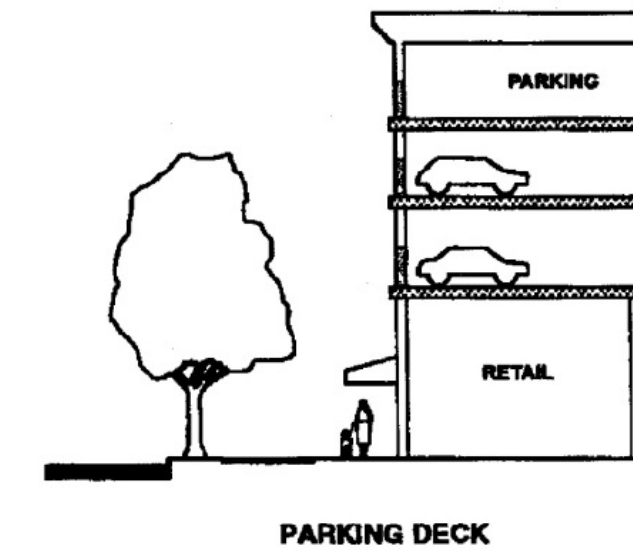

Figure 17C.123.40-A

3. Bicycle Parking.

Requirements for bicycle parking are found in SMC 17C.230.200. Bicycle parking provided in the streetscape can contribute to requirements in SMC 17C.230.200.

4. Site Lighting.

Surface parking lot and site lighting shall contribute to the visibility and safety of the site and adjacent rights-of-way, while not disturbing adjacent properties. Surface lot and site lighting shall adhere to the following standards:

a. Lighting types.

Pedestrian-scale fixtures shall be used for all lighting illuminating required Pedestrian Paths. Vehicle-scale fixtures may be used for general surface lot and site lighting. Lighting shall meet the dimensions of Figure 17C.123.40-B.

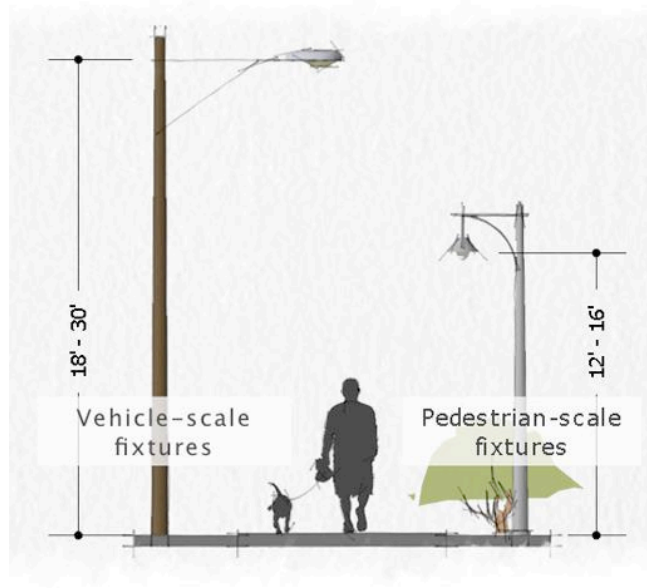

Figure 17C.123.40-B

b. Performance.

Parking lot and site lighting shall provide adequate night visibility and security by distributing a minimum of two foot-candles to a maximum of six foot-candles of illumination at ground level. All lighting shall be shielded from producing off-site glare, directing light downward and away from adjacent properties.

5. Driveways/Site Access.

Driveway widths shall not exceed 24 feet, and curb cuts shall not exceed 30 feet for combined entry/exits.

6. Pedestrian Walkways.

a. Within surface lots containing more than 30 parking stalls, pedestrian-friendly walkways shall be provided between the surface lots and building entrances.

b. Pedestrian Paths shall be not less than five feet wide and be clearly defined, using at least two of the following:

i. Six-inch vertical curbing

ii. Textured paving, including across vehicle lanes

iii. Continuous landscaped area at a minimum of 3 feet wide on at least one side of the walkway.

Section 6. That SMC Section 17C.123.060 is amended to read as follows:

Section 17C.123.060 (~~(Architectural Requirements)~~) Streetscape Requirements

~~((This section identifies general architectural requirements and guidelines, articulating basic façade requirements, roofline objectives, mechanical screening and other considerations. These requirements and guidelines establish important functional and aesthetic characteristics sought by the community and expressed by the Regulating Plan, ensuring the proper “fit” within the surrounding neighborhood.~~

~~A. Building Base.~~

~~For CA-1, CA2, CA3 and all Shopfront Street areas, building façades shall include a visually prominent plinth or base, helping establish pedestrian-scaled features and aesthetically tying the building to the street level. Building bases shall measure between 9” and 16” above adjacent grade, and utilize at least one of the following:~~

- ~~1. “Heavier” material composition, such as a stronger, more permanent material than used on upper portions of the façade.~~
- ~~2. A horizontal projection showing visible thickening of the wall surface that may be accompanied by a change of material and/or color.~~
- ~~3. A horizontal architectural line or feature, such as a belt course or secondary cornice, at or below the top of the first story and providing visual separation between the first two floors (See Figure 17C.123.060-A).~~

~~B. Primary Building Entries.~~

~~For CA-1, CA2, CA3 and all Shopfront Street areas, Primary Building Entries shall face the street and be made visually prominent, including the use of a recommended accent material and at least one of the following:~~

- ~~1. Recessed entrance. Recessed entrance shall be recessed at least 3’ from the building face.~~
- ~~2. Canopy or awning. Canopy or awning shall extend at least 5’ from the building face, with a minimum height clearance of 8’ above the sidewalk.~~
- ~~3. Inclusion of a volume that protrudes from the rest of building surface or an Architectural Roof Structure element physically or visually integrated with the Primary Building Entry (See Figure 17C.123.060-B).~~
- ~~4. For mixed-use buildings, entrances to residential, office or other upper story uses shall be clearly distinguishable in form and location from retail entrances.))~~



~~((Figure 17C.123.060-A: Illustration of building base, pedestrian-scale signs and other building elements described in the FBC.))~~

~~[NOTE: Delete graphic above]~~



~~((Figure 17C.123.060-B: Primary Building Entrances must face the street and be made visually prominent using one or more architectural approaches listed in 17C.123.070-B.))~~

~~[NOTE: Delete graphic above]~~

~~C. — Street-level Detailing.~~

~~For CA-1, CA2, CA3 and all Shopfront Street areas, street-level façades shall help create a more welcoming, aesthetically rich pedestrian environment by incorporating at least four of the following elements:~~

- ~~1. — Canopies or awnings spanning at least 25% of the building façade. Canopy or awning shall extend at least 5' from the building face and shall not be closer than 2' from the curb, with a minimum height clearance of 8' above the sidewalk.~~
- ~~2. — Pedestrian-Scaled Signs, mounted to the building or permanent overhang.~~
- ~~3. — Decorative sconce, lantern or similar lighting, mounted to the building.~~
- ~~4. — Projecting windowsills.~~
- ~~5. — Decorative kick plates for entry doors.~~
- ~~6. — Hanging planters supported by brackets mounted to the building.~~

~~D. — Façade Transparency.~~

~~Building façades shall include substantial glazing, providing visual connectivity between activities inside and outside a building. Regarding glazing, the following provisions shall apply:~~

- ~~1. If fronting along a Shopfront Street, ground floor glazing shall be at least ten feet (10') in height and no more than three feet (3') above adjacent sidewalk or grade.~~
- ~~2. If facing a public street, upper floor façades shall include a minimum of 30% clear glass windows.~~
- ~~3. The total glazing expressed as a minimum percentage of ground floor façades shall meet the specifications provided in Table 17C.123.060-1.~~

Table 17C.123.060-1 Glazing minimums, ground floor facades*				
	CA-1	CA-2	CA-3	CA4
Along Shopfront Street	60%	60%	50%	N/A
Along Non-Shopfront Street	40%	30%	30%	30%
*Glazing percentages may include windows and doors.				

~~E. Blank Walls.~~

~~Minimizing blank or undifferentiated façade walls helps ensure that buildings contribute to an engaging pedestrian environment. In all CA areas, blank façade walls longer than 30' along any public right-of-way shall be enhanced or screened by incorporating the following:~~

- ~~1. Vegetation such as espalier trees and/or vines planted adjacent to the wall surfaces.~~
- ~~2. Architectural detailing, such as reveals, contrasting materials, bas-relief detailing, artwork, murals, or decorative trellises.~~
- ~~3. Roof Lines.~~

~~F. In all CA areas, roofline elements shall adhere to the following standards:~~

- ~~1. Pitched or sloping roofs shall have a minimum slope of 4:12 and a maximum slope of 12:12 (rise:run).~~
- ~~2. Buildings with flat roofs shall include an extended parapet on all building sides, creating a defined cornice or prominent top edge.~~
- ~~3. Non-Enclosed, Enclosed and Architectural Roof Structure elements as defined by this code in are exempt from sections 17C.123.060 F.1 and~~

~~17C.123.060 F.2. Height limitations for such elements are provided in 17C.123.040.~~

~~G. Equipment Screening.~~

~~In all CA zones visible from public rights-of-way, mechanical and electrical equipment including HVAC units, transformers, antennae and receiving dishes shall be screened from view, adhering to the following standards:~~

- ~~1. Rooftop mechanical and electrical equipment shall be screened by a parapet wall, enclosed within roof volumes or other building elements designed as an integral part of the building's architecture.~~
- ~~2. Ground-level mechanical and electrical equipment shall be enclosed within secondary building elements, or screened by features designed to coordinate with the architectural character of the primary structure. Picket or chain-link fencing may not be used (See Figure 17C.123.060 C).~~

~~H. Service Area Screening.~~

~~In all CA zones, service, loading and trash collection areas shall be hidden or screened from view along public rights-of-way, and shall not face any public street or residential area unless no other location is possible. Service areas shall be hidden from view using a screen wall constructed of masonry, wood or metal, designed to coordinate with the architectural character of the primary structure. Screen walls shall also include one or more of the following:~~

- ~~1. Vegetation such as espalier trees and/or vines planted adjacent to the wall surfaces.~~
- ~~2. Architectural detailing, such as reveals, contrasting materials, bas-relief detailing, artwork, murals, or decorative trellises.~~

~~I. Sign Standards.~~

~~For sign standards applying to all CA zones, see City of Spokane Municipal Code, Chapter 17C.240. For the purposes of signs standards CA1 and CA2 shall be evaluated as CC1 zone; CA3 shall be evaluated as CC2; and CA4 shall be evaluated as a residential zone.~~

~~J. Materials.~~

~~Use of quality building materials ensures that projects contribute to the overall value and character of properties within and adjacent to HFBC Limits. Buildings shall employ durable and high-quality materials, such as steel, glass, brick, stone, and/or wood. (See Figure 17C.123.060 D).))~~

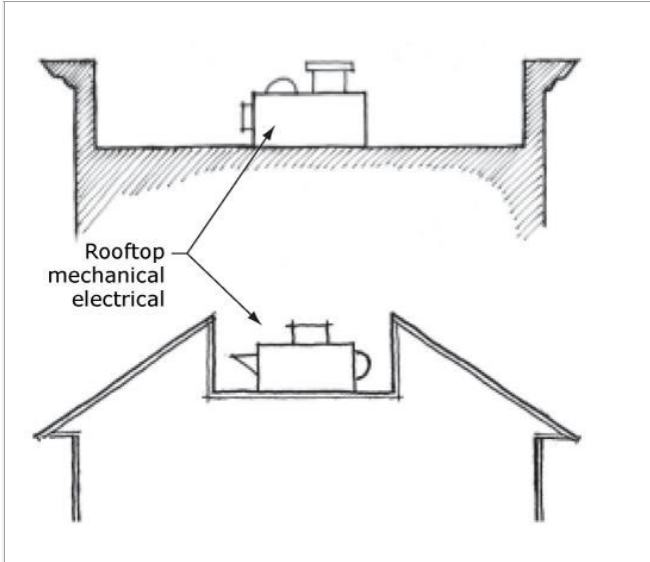

~~((Figure 17C.123.060-C: Rooftop and ground-level equipment must be screened from view along public rights-of-way. Here mechanical systems are hidden by cornice and roof elements.))~~

~~[NOTE: Delete graphic above]~~



~~((Figure 17C.123.060-D: The HFBC provides standards and guidelines regarding building materials, helping realize community expectations for the corridor and neighborhood.))~~

~~[NOTE: Delete graphic above]~~

~~((K.—Guidelines.~~

~~In addition to the material standards defined in this section, the following guidelines are included to further define community expectations for projects within all CA zones within Regulating Plan limits. The guidelines presented in this section are optional and intended to express desirable characteristics for the district.~~

- ~~1.—The use of sustainably harvested, salvaged, recycled/reused products is encouraged wherever possible.~~
- ~~2.—Optional—Recommended entry treatments include special paving materials such as ceramic tile; ornamental ceiling treatments; decorative light fixtures; decorative door pulls, escutcheons, hinges, and other hardware.~~
- ~~3.—Authentic materials and methods of construction should be used to the greatest degree possible. Materials made to simulate higher value materials and construction types may be used for reasons of economy, but should be durable and closely match the proportions, surface finishes, and colors of the materials they simulate.~~

- ~~4. When veneers are used, detailing and installation should give the appearance of full-depth material, avoiding the exposure of veneer sides, including use of wrap-around corner pieces.~~
- ~~5. The location and spacing of panel or expansion joints should be incorporated into the façade composition. Castings should be shaped to form architectural profiles that create bases, cornices, pilasters and other elements contributing to the façade composition.~~
- ~~6. Cladding and/or accent materials on the primary building should be carried over onto additions, accessory buildings and site features.~~
- ~~7. Recommended cladding materials include:
 - ~~a. Brick. Red brick is characteristic of the Spokane region, although other colors may be used as well. Full size brick veneer is preferable to thin brick tile.~~
 - ~~b. Stone. Granite, limestone, sandstone, and river rock are preferred stone types. Stone veneer and cast stone simulating these types is allowable.~~
 - ~~c. Cast concrete. Precast or exposed site-cast structural concrete is acceptable. Pigments, special aggregates and surface textures should be exploited to achieve architectural effects.~~
 - ~~d. Concrete block. Where used, creativity in selecting block sizes, surface textures, course patterns and colors is encouraged.~~
 - ~~e. Wood. Horizontal sidings such as clapboard, tongue-in-groove, shingles or shakes, or vertical sidings such as board and batten are acceptable. Trim elements should be used for all wood siding types. Heavy timber detailing and exposed bracing may be used where appropriate to the building style.~~
 - ~~f. Fiber cement or cementitious siding. Fiber cement planks, panels and shingles and are an acceptable substitute for wood siding when used in the formats described above under "Wood."~~
 - ~~g. Stucco. Stucco, cement plaster or stucco-like finishes such as EIFS may be used along ground floor portions of rear or side service and parking exposures, provided the building base treatment used along the street façade is continued. Stucco of any type should not be used along ground floor portions of street exposures.~~~~

8. ~~Accent materials are typically used at building entrances, window and door frames, wall bases, cornices, wainscot materials and for copings, trim, and other special elements. Recommended accent materials include:~~
 - a. ~~Brick. Red brick is characteristic of the Spokane region, although other colors may be used as well. Full size brick veneer is preferable to thin brick tile.~~
 - b. ~~Stone. Granite, limestone, sandstone, and river rock are preferred stone types. Stone veneer and cast stone simulating these types is allowable.~~
 - c. ~~Cast concrete. Precast or exposed site-cast structural concrete is acceptable. Pigments, special aggregates and surface textures should be exploited to achieve architectural effects.~~
 - d. ~~Concrete block. Where used, creativity in selecting block sizes, surface textures, course patterns and colors is encouraged.~~
 - e. ~~Tile. Ceramic, terra cotta and cementitious tile, whether glazed or unglazed is acceptable.~~
 - f. ~~Metal. Profile, corrugated and other sheet, rolled or extruded metal is acceptable. Metal accents should have trim elements to protect edges, and be of adequate thickness to resist dents and impacts. Surfaces should be treated with a high quality, fade-resistant coating system or paint such as Kynar and Tnemec. Copper, zinc and weathering steel may be left exposed.~~
9. ~~Rooflines. Varied roof planes, cornice elements, overhanging eave and roof decks are encouraged, as they increase visual interest and help implement desired character objectives.~~
10. ~~Recommended materials for roofs exposed and visible from public rights of way include:~~
 - a. ~~Metal seam roofing. Finishes should be anodized, fluoro-coated or painted. Copper, zinc and weathering steel may be left exposed.~~
 - b. ~~Slate or slate-like materials.~~
 - c. ~~Sheet metal shingles.~~
 - d. ~~Asphalt shingles. Projects using asphalt shingles should use the highest quality commercial grade materials, and be provided with adequate trim elements.~~

11. ~~Special Paving. Cobblestones or a stamped concrete cobblestone or brick pattern are recommended for special paving and pedestrian buffer strips~~

12. ~~Frontage Types. Figure 17C.123.060E clarifies expectations for how buildings will meet the street.))~~

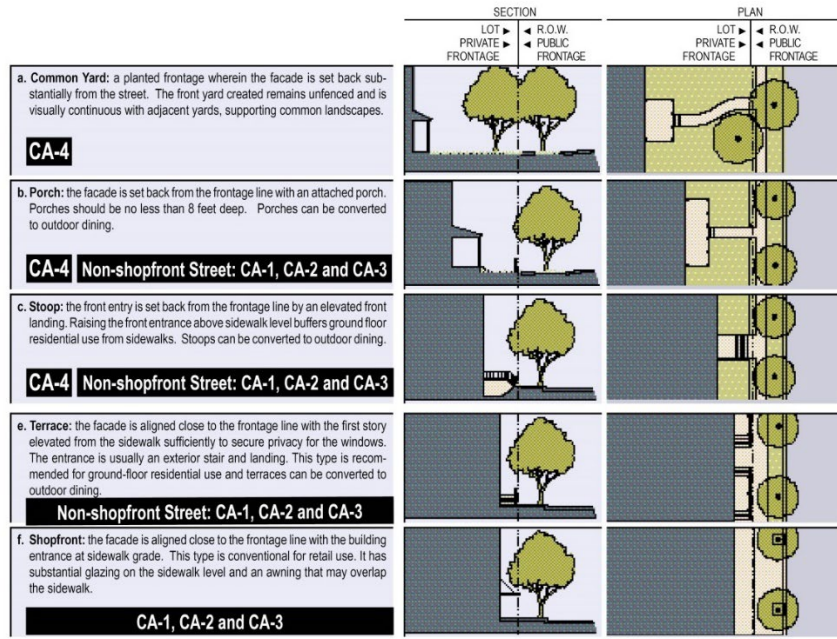

~~((Figure 17C.123.060 E: Frontage Types))~~

[NOTE: Delete graphic above]

This section of the Hamilton Form-Based Code (FBC) identifies features and specifications for area streets and alley. The standards work to establish the type of active, economically vibrant public realm sought by the area community, balancing vehicular access with the safety and convenience of transit, walking, biking, and rolling.

A. Streetscape Requirements.

Required streetscape features and dimensions of those elements are identified in Table 17C.123.050-1.

Table 17C.123.060-1			
Streetscape Requirements [1]			
	CA1	Shopfront	Alley
Sidewalks			
Overall Width (each side)	12 ft.		N/A

Type	4' x 2' scored concrete		N/A
Clear Pedestrian Zone	7 ft. [2]		N/A
Buffer Zone (each side) [3]	5 ft.		N/A
Street Furnishings			
Lighting, types [4]	P	P	V
Planting, types [5]	S	S/M	N/A
Benches [6] [7]	R	R	N/A
Trash receptacles [6] [7]	R	R	N/A
Bicycle parking [6] [7]	N/R	R	N/A
[1] See City of Spokane Department of Engineering Design Standards for additional specifications.			
[2] Along Columbus Street, a 10-foot wide Clear Pedestrian Zone is required.			
[3] A reduced width may be permitted with an approved alternative planting system, such as modular suspended pavement systems, with the approval of Urban Forestry.			
[4] "P" = Pedestrian scale; "V" = Vehicle scale			
[5] "S" = Street trees; "M" = Median planting			
[6] "R" = Required; "N/R" = Not required			
[7] Buildings less than 10,000 sf. are encouraged to include such amenities but are not required.			

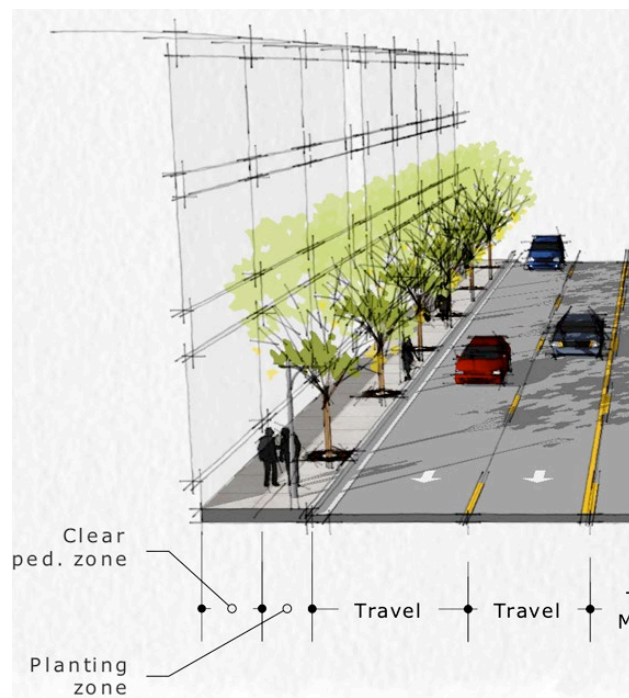

Figure 17C.123.050-A –
Desired Frontage Characteristics.

B. Sidewalks.

The composition and color of sidewalks shall be as described in Table 17C.123.050-1 and shall be continued as they cross-vehicular driveways (See Figure 17C.123.050-B).

1. When the existing sidewalk width is less than 12 feet, structures shall be allowed no closer than 12 feet from the back of the curb.
2. When the existing sidewalk width is greater than the bare minimum of 12 feet, the existing sidewalk width shall not be reduced or encroached upon by new development.

C. Street Furnishings.

Street furnishings including light poles, benches, and trash receptacles shall be placed between tree locations within the Planting Zone. Street furnishings shall not impede the clear view triangle. Street furnishings required in Table 17C.123.050-1 are to be provided as follows:

1. Planting.

Street trees must be installed and maintained by the adjacent property in all streets bordering development. Generally, street trees should be spaced on average 25 feet apart. At a minimum, street trees shall provide a continuous row of City-approved trees spaced according to mature canopy size, plus one or more types of City-approved ground cover. Additional requirements for landscaping are stated in chapter 17C.200 SMC, Landscaping and Screening.

2. Lighting.

City-approved Traditional Series pedestrian scale lighting as shown in Figure 17C.123.050-C (flower basket optional) shall be provided and spaced at an average 50 to 60 feet apart, generally midway between required street trees and centered thirty-six (36") from the curb to ensure a uniform distance from the street edge along the entire street.

Hamilton FBC Pedestrian Light Standards

C.1. The City of Spokane Traditional Series pedestrian acorn light (flower basket optional) shall be installed at an average 25' spacing generally spaced midway between street trees and centered thirty-six inches (36") from the curb to ensure a uniform distance from street edge along the entire street.

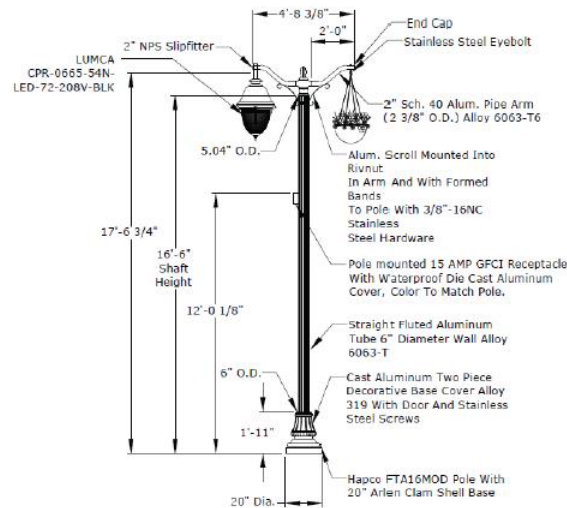

Traditional Series Light Fixture
Not to Scale

Figure 17C.123.050-C

D. Bicycle Parking.

Bicycle parking is encouraged where the requirement for the Planting Zone and Clear Pedestrian Zone can be met. Bicycle parking provided in the streetscape can contribute to requirements in SMC 17C.230.200.

E. Temporary Encroachments.

Temporary and intermittent sidewalk encroachments including café seating, planters, ramps, steps, and sandwich board signs may be located in the Planting Zone without restriction, or in the Clear Pedestrian Zone provided a pathway of at least six (6) feet wide remains free of such obstructions (See Figure 17C.123.050-D).



Figure 17C.123.050-D –
Temporary sidewalk encroachments are allowed in the Planting Zone, or
in the Clear Pedestrian Zone as per Table 17C.123.050-1.

F. City approved benches and trash receptacles shall be provided for all buildings larger than 10,000 sf. Buildings less than this size are encouraged to include such amenities.

Section 7. That SMC Section 17C.123.070 is amended to read as follows:

Section 17C.123.070 ((Additional Requirements)) Design Standards

~~((A.—Drive Through Facilities:~~

~~Drive-Through Facilities are prohibited in all Context Areas of the FBC.~~

~~B.—Nonconforming Situations:~~

~~Existing development that does not conform to the development standards of this chapter is subject to the standards of chapter 17C.210 SMC, Nonconforming Situations.~~

~~C. Nuisance-related Impacts.~~

- ~~1. Off-site impacts. All nonresidential uses including their accessory uses must comply with the standards of Chapter 17C.220, Off-Site Impacts.~~
- ~~2. Other nuisances are further regulated by state and local laws.~~

~~D. Outdoor Activities~~

- ~~1. The standards of this section are intended to assure that outdoor sales, display, storage, and work activities:~~
 - ~~a. will be consistent with the desired character of the zone;~~
 - ~~b. will not be a detriment to the overall appearance of an area;~~
 - ~~c. will not have adverse impacts on adjacent properties, especially those with residential uses; and~~
 - ~~d. will not have an adverse impact on the environment.~~
- ~~2. Outdoor activities associated with permitted uses shall be permitted subject to the standards of the zone and as described below.~~
- ~~3. Outdoor Sales and Display Areas.~~
 - ~~a. In the CA1—CA3 zones, outdoor sales, and display areas are limited to forty percent of lot area or one thousand five hundred square feet, whichever is less.~~
 - ~~b. Outdoor sales and display areas for uses in the industrial use categories are not allowed in the CA zones.~~
 - ~~c. In the CA 4 zone, outdoor sales and display areas are prohibited.~~
- ~~4. Outdoor Storage Areas.~~
 - ~~a. Outdoor storage areas are not permitted in the CA1—CA3 zones.~~
 - ~~b. Outdoor storage areas in CA4 zones are subject to the standards of SMC 17C.110.270 Exterior Storage—Residential Zones.~~

~~5. Outdoor Activity Area Improvements.~~

- ~~a. Outdoor activities shall be screened and landscaped according to the provisions of chapter 17C.200 SMC, Landscaping and Screening.~~
- ~~b. In order to control dust and mud, all vehicle circulation areas must be paved.~~

~~E. Fences~~

- ~~1. Purpose: The fence standards promote the positive benefits of fences without adversely impacting the community or endangering public or vehicle safety. Fences near streets are kept low in order to allow visibility into and out of the site and to ensure visibility for motorists. Fences in any required side or rear setback are limited in height so as to not conflict with the purpose for the setback.~~
- ~~2. Type of Fences The standards apply to walls, fences, and screens of all types whether open, solid, wood, metal, wire, masonry, or other material.~~
- ~~3. Location, Height, and Design.~~
 - ~~a. Street Setbacks.~~
 - ~~i. No fence or other structure is allowed within twelve feet from the back of the curb, consistent with the required sidewalk width of SMC 17C.123.060.~~
 - ~~ii. Fences up to three and one-half feet high are allowed in a required street setback that is measured from a front lot line.~~
 - ~~iii. Fences up to six feet high are allowed in required setback that is measured from a side lot line.~~
 - ~~iv. Fences shall not reduce the required setback width of SMC 17C.123.060.~~
 - ~~v. Fences up to six feet high are allowed in required side or rear setbacks except when the side or rear setback abuts a pedestrian connection. When the side or rear setback abuts a pedestrian connection, fences are limited to three and one-half feet in height.~~

~~vi. The height for fences that are not in required setbacks is the same as the regular height limits of the zone.~~

~~b. Sight-obscuring Fences and Walls.~~

~~i. Any required or non-required sight-obscuring fences, walls, and other structures over three and one-half feet high, and within fifteen feet of a street lot line shall either be placed on the interior side of a L2 see-through buffer landscaping area at least five feet in depth (See chapter 17C.200 SMC, Landscaping and Screening), or meet the treatment of blank walls intent outlined in SMC 17C.122.060 Initial Design Standards and Guidelines for Center and Corridors.~~

~~4. Prohibited Fences.~~

~~a. No person may erect or maintain a fence or barrier consisting of or containing barbed, razor, concertina, or similar wire except that up to three strands of barbed wire may be placed atop a lawful fence exceeding six feet in height above grade.~~

~~b. No person may maintain a fence or barrier charged with electricity.~~

~~c. A fence, wall, or other structure shall not be placed within a public right-of-way without an approved covenant as provided in SMC 17G.010.160 and any such structure is subject to the height requirement for the adjoining setback.~~

~~d. No permanent fence may reduce the required sidewalk width.~~

~~5. Visibility at Intersections.~~

~~a. A fence, wall, hedge, or other improvement may not be erected or maintained at the corner of a lot so as to obstruct the view of travelers upon the streets~~

~~b. Subject to the authority of the traffic engineer to make adjustments and special requirements in particular cases, no fence exceeding a height of thirty-six inches above the curb may be inside the:~~

~~i. right isosceles triangle having sides of fifty feet measured along the curb line of each intersecting residential street; or~~

~~ii. right triangle having a fifteen-foot side measured along the curb line of the residential street and a seventy-five-foot side along the curb line of the intersecting arterial street, except~~

~~that when the arterial street has a speed limit of thirty-five miles per hour, the triangle has a side along such arterial of one hundred twenty-two feet; or~~

- ~~iii. right isosceles triangle having sides of seven feet measured along the right-of-way line of an alley and:
 - ~~1. the inside line of the sidewalk; or~~
 - ~~2. if there is no sidewalk, a line seven feet inside the curb line.~~~~

~~6. Enclosures for Pools, Hot Tubs, or Ponds.~~

- ~~a. A person maintaining a swimming pool, hot tub, pond, or other impoundment of water exceeding five thousand gallons and eighteen inches or more in depth and located on private property is required to construct and maintain an approved fence by which the pool or other water feature is enclosed and inaccessible by small children.~~
- ~~b. The required pool enclosure must be at least fifty-four inches high and may be a fence, wall, building, or other structure approved by the building services department.~~
- ~~c. If the enclosure is a woven wire fence, it is required to be built to discourage climbing.~~
- ~~d. No opening, except a door or gate may exceed four inches in any dimension.~~
- ~~e. Any door or gate in the pool enclosure, except when part of the occupied dwelling unit, must have self-closing and self-locking equipment by which the door or gate is kept secure when not in use. A latch or lock release on the outside of the door or gate must be at least fifty-four inches above the ground.~~
- ~~f. Outside of the door or gate must be at least fifty-four inches above the ground.~~

~~7. Reference to Other Standards.~~

- ~~1. Building permits are required by the building services department for all fences including the replacement of existing fences. A permit is not required to repair an existing fence.~~

~~F. Creation of new lots is subject to the standards of chapter 17G.080 SMC.))~~

All development within the Hamilton Form-Based Code (FBC) must address the following design standards, administered pursuant to SMC 17C.111.015 Design Standards Administration. When existing development is expanded, only those portions of the development that are new or renovated must meet the standards in this section.

This section also includes Guidelines that further define community desires for new development and redevelopment within the Hamilton FBC area. The Guidelines are optional and intended to express the desired built form for the area.

A. Building Base.

Building façades shall include a visually prominent plinth or base, helping establish pedestrian-scaled features and aesthetically tying the building to the street level. Building bases shall measure between 9 inches and 16 inches above adjacent grade, and utilize at least one of the following:

1. A horizontal projection of at least 3 inches that may be accompanied by a change of material and/or color.
2. A horizontal architectural line or feature, such as a belt course or secondary cornice, at or below the top of the first story and providing visual separation between the first two floors (See Figure 17C.123.060-A).

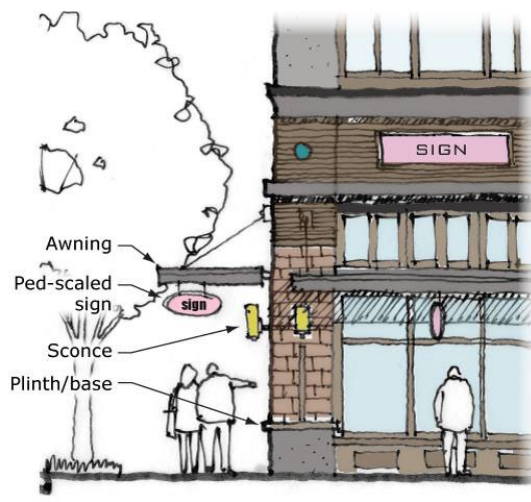

Figure 17C.123.060-A – Illustration of building base, pedestrian scale signs and other building elements described in the FBC.

B. Primary Building Entries.

1. Primary building entries shall face the street and be made visually prominent, including at least one of the following:
 - a. An entrance recessed at least 3' from the building face.
 - b. A canopy or awning that extends at least 5' from the building face, with a minimum height clearance of 8' above the sidewalk.
2. For mixed-use buildings, entrances to residential, office or other upper story uses shall be clearly distinguishable in form and location from retail entrances.

C. Street-level Detailing.

Street-level façades shall help create a more welcoming, aesthetically rich pedestrian environment by incorporating at least four of the following elements:

1. Canopies or awnings spanning at least 25% of the building façade.
2. Canopy or awning shall extend at least 5' from the building face and shall not be closer than 2' from the curb, with a minimum height clearance of 8' above the sidewalk.
3. Pedestrian-Scaled Signs, mounted to the building or permanent overhang.
4. Decorative sconce, lantern, or similar lighting, mounted to the building.
5. Projecting windowsills.
6. Decorative kick plates for entry doors.
7. Hanging planters supported by brackets mounted to the building.

D. Façade Transparency.

Building façades shall include substantial glazing, providing visual connectivity between activities inside and outside a building. Regarding glazing, the following provisions shall apply:

1. If within a Shopfront Designation, ground floor glazing facing a public right-of-way shall be at least ten feet (10') in height and no more than three feet (3') above adjacent sidewalk or grade.
2. The total glazing expressed as a minimum percentage of ground floor façades shall meet the specifications provided in Table 17C.123.060-1.

Table 17C.123.070-1		
Glazing minimums, ground floor facades [1]		
	CA1	Shopfront
<u>Non-Residential – within 10-ft. of the sidewalk</u>	<u>40%</u>	<u>60%</u>

<u>Non-Residential – more than 10-ft. from the sidewalk</u>	<u>15%</u>	<u>15%</u>
<u>Residential</u>	<u>15%</u>	<u>15%</u>
<u>[1] Glazing percentages may include windows and doors.</u>		

E. Ground Floor Residential.

In addition to other standards specific to residential development found within this chapter and in order to increase the privacy of residents and provide an effective transition between the public and private realm, ground floor residential within 10-ft. of a sidewalk shall:

1. Be elevated a minimum of 30 inches from grade, with alternatives approved by the Planning Director to accommodate units meeting residential visitability standards found in SMC 17C.111.600;
2. Incorporate a patio, porch, deck, or stoop with covered entry between the entry and sidewalk; and
3. Integrate L3 Open Area Landscaping, as defined in SMC 17C.200.030 Landscape Types, between the sidewalk and building.

F. Blank Walls.

Minimizing blank or undifferentiated façade walls helps ensure that buildings contribute to an engaging pedestrian environment. Blank façade walls longer than 30' along any public right-of-way shall be enhanced or screened by incorporating the following:

1. Public art such as murals;
2. Vegetation such as espalier trees and/or vines planted adjacent to the wall surfaces;
3. Architectural detailing, such as reveals, contrasting materials, bas-relief detailing, or decorative trellises; or
4. Roof Lines.

G. Roof Lines.

1. Pitched or sloping roofs shall have a minimum slope of 4:12 and a maximum slope of 12:12 (rise:run).
2. Buildings with flat roofs shall include an extended parapet on all building sides, creating a defined cornice or prominent top edge.
3. Non-Enclosed, Enclosed, and Architectural Roof Structure elements as defined by this code are exempt from sections 17C.123.060(G)(1) and 17C.123.060(G)(2). Height limitations for such elements are provided in Table 17C.123.030-1.

H. Equipment Screening.

Mechanical and electrical equipment including HVAC units, transformers, antennae and receiving dishes visible from public rights-of-way shall be screened from view, adhering to the following standards:

1. Rooftop mechanical and electrical equipment shall be screened their full height by a parapet wall, enclosed within roof volumes or other building elements designed as an integral part of the building's architecture.
2. Ground-level mechanical and electrical equipment shall be enclosed within secondary building elements or screened by features designed to coordinate with the architecture of the primary structure. Year-round vegetative screening the height of the equipment at planting is permitted. Picket or chain-link fencing may not be used (See Figure 17C.123.060-B).

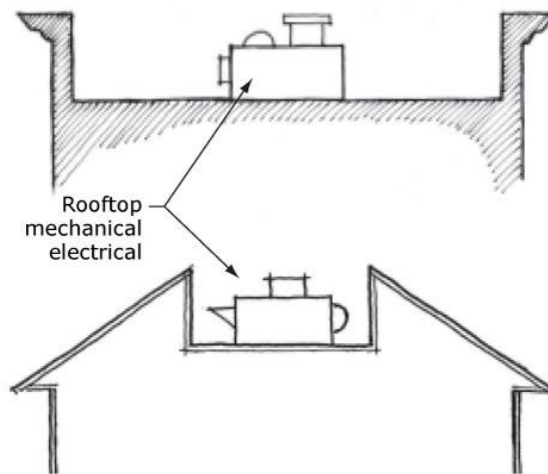

Figure 17C.123.060-B – Rooftop and ground-level equipment must be screened from view along public rights-of-way. Here mechanical systems are hidden by cornice and roof elements.

I. Service Area Screening.

Service, loading, and trash collection areas shall be hidden or screened from view along public rights-of way and shall not face any public street or residential area unless no other location is possible. Service areas shall be hidden from view using a screen wall constructed of masonry, wood, or metal, designed to coordinate with the architecture of the primary structure. Screen walls shall also include one or more of the following:

1. Vegetation such as espalier trees and/or vines planted adjacent to the wall surfaces.
2. Architectural detailing, such as reveals, contrasting materials, bas-relief detailing, or decorative trellises.
3. Public art such as murals.

J. Sign Standards.

See City of Spokane Municipal Code, Chapter 17C.240 for sign standards. Signs within the CA zone are subject to the standards and guidelines contained in the Initial Design Standards and Guidelines for Centers and Corridors.

- K. Swimming pool, hot tub, pond, or other impoundment of water exceeding five thousand gallons and eighteen inches or more in depth must be located within a fully enclosed building.

L. Guidelines.

In addition to the material standards defined in this section, the following guidelines are included to further define community expectations for projects within the Hamilton FBC area. The guidelines presented in this section are optional and intended to express desirable characteristics for the district.

1. Sustainable Design.

- a. The use of sustainably harvested, salvaged, recycled, and reused products is encouraged wherever possible.
- b. The rehabilitation of older buildings should be considered before new construction. If removal is required, the deconstruction of existing development is encouraged.
- c. Integration of Green Stormwater Infrastructure (GSI) should be considered in conjunction with property redevelopment.
- d. Property owners are encouraged to replace or reduce ground cover like grass lawns and pavement with native and/or drought tolerant plantings.
- e. The installation and maintenance of green roofs is encouraged.

2. Trail-Oriented Development.

For properties along the Centennial Trail, development is encouraged to orient towards the trail, which can be accomplished by:

- a. Having patios and decks that overlook the trail.
- b. Having an increased level of façade transparency to increase “eyes on the trail”.
- c. Having a covered entry facing the trail.

d. Avoiding tall fences and blank walls facing the trail.

3. Building Entries.

Recommended entry treatments include special paving materials such as ceramic tile; ornamental ceiling treatments; decorative light fixtures; decorative door pulls, escutcheons, hinges, and other hardware.

4. Building Materials.

a. Authentic materials and methods of construction should be used to the greatest degree possible. Materials made to simulate higher-value materials and construction types may be used for reasons of economy, but should be durable and closely match the proportions, surface finishes, and colors of the materials they simulate.

b. When veneers are used, detailing and installation should give the appearance of full-depth material, avoiding the exposure of veneer sides, including the use of wrap-around corner pieces.

c. Cladding and/or accent materials on the primary building should be carried over onto additions, accessory buildings, and site features.

d. Recommended cladding materials include:

i. Brick. Red brick is characteristic of the Spokane region, although other colors may be used as well. Full size brick veneer is preferable to thin brick tile.

ii. Stone. Granite, limestone, sandstone, and river rock are preferred stone types. Stone veneer and cast stone simulating these types is allowable.

iii. Cast concrete. Precast or exposed site-cast structural concrete is acceptable. Pigments, special aggregates, and surface textures should be exploited to achieve architectural effects.

iv. Concrete block. Where used, creativity in selecting block sizes, surface textures, course patterns and colors is encouraged.

v. Wood. Horizontal sidings such as clapboard, tongue-in-groove, shingles or shakes, or vertical sidings such as board and batten are acceptable. Trim elements should be used for all wood siding types. Heavy timber detailing and exposed bracing may be used where appropriate to the building style.

vi. Fiber-cement or cementitious siding. Fiber-cement planks, panels and shingles and are an acceptable substitute for

wood siding when used in the formats described above under "Wood."

- vii. Stucco. Stucco, cement plaster or stucco-like finishes such as EIFS may be used along ground floor portions of rear or side service and parking exposures, provided the building base treatment used along the street façade is continued. Stucco of any type should not be used along ground floor portions of street exposures.
- e. Accent materials are typically used at building entrances, window and door frames, wall bases, cornices, wainscot materials and for copings, trim, and other special elements. Recommended accent materials include:
 - i. Brick. Red brick is characteristic of the Spokane region, although other colors may be used as well. Full size brick veneer is preferable to thin brick tile.
 - ii. Stone. Granite, limestone, sandstone, and river rock are preferred stone types. Stone veneer and cast stone simulating these types is allowable.
 - iii. Cast concrete. Precast or exposed site-cast structural concrete is acceptable. Pigments, special aggregates and surface textures should be exploited to achieve architectural effects.
 - iv. Concrete block. Where used, creativity in selecting block sizes, surface textures, course patterns and colors is encouraged.
 - v. Tile. Ceramic, terra cotta and cementitious tile, whether glazed or unglazed is acceptable.
 - vi. Metal. Profile, corrugated and other sheet, rolled or extruded metal is acceptable. Metal accents should have trim elements to protect edges, and be of adequate thickness to resist dents and impacts. Surfaces should be treated with a high quality, fade-resistant coating system or paint such as Kynar and Tnemec. Copper, zinc and weathering steel may be left exposed.
- f. The location and spacing of panel or expansion joints should be incorporated into the façade composition. Castings should be shaped to form architectural profiles that create bases, cornices, pilasters and other elements contributing to the façade composition.

5. Rooflines.

Varied roof planes, cornice elements, overhanging eave and roof decks are encouraged, as they increase visual interest and help implement desired character objectives.

a. Recommended materials for roofs exposed and visible from public rights of way include:

i. Metal seam roofing. Finishes should be anodized, fluoro-coated or painted. Copper, zinc and weathering steel may be left exposed.

ii. Slate or slate-like materials.

iii. Sheet metal shingles.

iv. Asphalt shingles. Projects using asphalt shingles should use the highest quality commercial grade materials and be provided with adequate trim elements.

6. Special Paving.

Cobblestones or a stamped concrete cobblestone or brick pattern are recommended for special paving and pedestrian buffer strips.

Section 8. That SMC Section 17C.123.080 is amended to read as follows:

Section 17C.123.080 (~~(Building Type Catalogs)~~ Additional Requirements)

A. Outdoor Activities

The standards of this section are intended to assure that outdoor sales, display, storage, and work activities will not have adverse impacts on adjacent properties or the environment, while providing the envisioned built form within the area.

1. Outdoor Sales and Display Areas.

a. Outdoor sales and display areas are limited to forty percent of lot area or one thousand five hundred square feet, whichever is less, in the CA1 zone.

b. Outdoor sales and display areas for uses in the industrial use categories are not allowed in the CA1 zone.

c. In the Shopfront designations, accessory outdoor sales are permitted so long as the Clear Pedestrian Zone and Buffer Zone is maintained.

d. In the Shopfront designations, outdoor display areas are prohibited.

2. Outdoor Storage Areas.

a. Outdoor storage areas are not permitted.

3. Outdoor Activity Area Improvements.

- a. Outdoor activities shall be screened and landscaped according to the provisions of chapter 17C.200 SMC, Landscaping and Screening.
- b. In order to control dust and mud, all vehicle circulation areas must be paved.

B. Fences.

The fence standards avoid adverse impacts on the area while protecting public or vehicle safety. Fences near streets are kept low in order to allow visibility into and out of the site and to ensure visibility for motorists. Fences in any required side or rear setback are limited in height so as to not conflict with the purpose for the setback.

1. Type of Fences.

The standards apply to walls, fences, and screens of all types whether open, solid, wood, metal, wire, masonry, or other material.

2. Location, Height, and Design

a. Street Setbacks.

- i. No fence or other structure is allowed within twelve feet from the back of the curb, consistent with the required sidewalk width of SMC 17C.123.050.
- ii. Fences up to three and one-half feet high are allowed in a required street setback.
- iii. Fences up to six feet high are allowed in required side or rear setbacks except when the side or rear setback abuts a pedestrian connection. When the side or rear setback abuts a pedestrian connection, fences are limited to three and one-half feet in height.
- iv. Fences shall not reduce the required setback width of SMC 17C.123.030.

b. Sight-obscuring Fences and Walls.

- i. Any required or non-required sight-obscuring fences, walls, and other structures over three and one-half feet high, and within fifteen feet of a street lot line shall either be placed on the interior side of a L2 see-through buffer landscaping area at least five feet in depth (See chapter 17C.200 SMC, Landscaping and Screening), or meet the treatment of blank

walls intent outlined in SMC 17C.122.060 – Initial Design Standards and Guidelines for Center and Corridors.

c. Fencing Material.

- i. Fence materials within the public right-of-way or within eight feet of a street lot line should be wrought iron or similar in appearance, aluminum, metal, or similar material.
- ii. Walls visible from streets shall be masonry, stone, brick, or similar construction.
- iii. Chain link fencing is not allowed that is visible from and/or adjacent to a public street.

3. Prohibited Fences.

- a. No person may erect or maintain a fence or barrier consisting of or containing barbed, razor, concertina, or similar wire.
- b. No person may maintain a fence or barrier charged with electricity.
- c. A fence, wall, or other structure shall not be placed within a public right-of-way without an approved covenant as provided in SMC 17G.010.160 and any such structure is subject to the height requirement for the adjoining setback.
- d. No permanent fence may reduce the required sidewalk width.

4. Visibility at Intersections.

A fence, wall, hedge, or other improvement may not be erected or maintained at the corner of a lot so as to obstruct the view of travelers upon the streets.

- 6. Subject to the authority of the traffic engineer to make adjustments and special requirements in particular cases, no fence exceeding a height of thirty-six inches above the curb may be located within the Clear View Triangle, as defined in Section 17A.020.030 “C” Definitions.

Context Area 1 (CA-1)

Hamilton FBC Building Character Visual Catalog

This visual catalog showcases the type, form, and general character of desired development within Context Area 1. Images are representational only.



CA-1 Non-Shopfront

See also CA-2, CA-3 and CA-4 Non-Shopfront.



CA-1 Corner

See also CA-2 and CA-3 Corner.



CA-1 Shopfront

See also CA-2 and CA-3 Shopfront.



CA-1 - 1 to 5 Story Buildings

[NOTE: Delete graphic above]

Context Area 2 (CA-2)

Hamilton FBC Building Character Visual Catalog

This visual catalog showcases the type, form, and general character of desired development within Context Area 2. Images are representational only.



CA-2 Non-Shopfront

See also CA-3 and CA-4 Non-Shopfront.



CA-2 Corner

See also CA-3 Corner.

CA-2 Shopfront

See also CA-3 Shopfront.



CA-2 - 1 to 4 Story Buildings

[NOTE: Delete graphic above]

Context Area 3 (CA-3)

Hamilton FBC Building Character Visual Catalog

This visual catalog showcases the type, form, and general character of desired development within Context Area 3. Images are representational only.



CA-3 Non-Shopfront

See also CA-4.



CA-3 Corner



CA-3 Shopfront



CA-3 - 1 to 2 Story Buildings

[NOTE: Delete graphic above]

Context Area 4 (CA-4)

Hamilton FBC Building Character Visual Catalog

This visual catalog showcases the type, form, and general character of desired development within Context Area 4. Images are representational only.

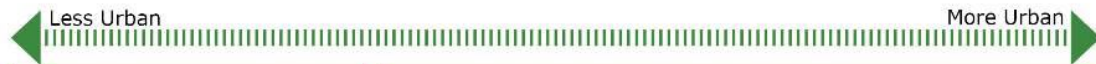

CA-4 Small Footprint



CA-4 Medium Footprint



[NOTE: Delete graphic above]

Context Area 4 (CA-4)

Hamilton FBC Building Character Visual Catalog

This visual catalog showcases the type, form, and general character of desired development within Context Area 4. Images are representational only.



CA-4 Large Footprint



Image borrowed from daybreakutah.com



Image borrowed from daybreakutah.com

[NOTE: Delete graphic above]

17C.111.230/17C.120.220 HEIGHT

The proposed Spokane Municipal Code Text Amendments related to building height are citywide and not limited to the South Logan Project Area. The citywide changes implement recommendations from the [South Logan TOD Plan](#), with citywide implementation ensuring consistency of height and height transitions throughout Spokane. The proposal includes replacing the allowed height of 70-feet with 75-feet to better permit podium-style development, as well as reducing the distance of and modifying the slope of required height transitions adjacent to R1 and R2 zones in order to increase the feasibility of development building to the allowed maximum height allowances.

Text with (~~strikethrough~~) is proposed to be repealed/modified with underlined text representing proposed text. Text without a strikethrough or underline is existing and not proposed to be modified.

Section 1. That SMC Section 17C.111.230 is amended to read as follows:

17C.111.230 Height

A. Purpose.

The height standards promote a reasonable building scale and relationship of one residence to another and they promote privacy for neighboring properties. The standards contained in this section reflect the general building scale and placement of houses in the City's neighborhoods.

B. Height Standards.

The maximum height standards for all structures are stated in Table 17C.111.205-2. The building height shall be measured using the following method (see Figure 17C.111.230-A):

1. Building height is the vertical distance from the average grade to the highest point of the roof or structure that is not listed as an exception to the maximum building height limits as listed in Section 17C.111.230(C).
2. Underground portions of the structure are not included in height calculations. The height of the structure shall be calculated from the point at which the sides meet the surface of the ground.
3. "Average grade" means the average of the ground level adjoining the building at all exterior walls. Where the ground level slopes away from the exterior walls, the reference point shall be established by the lowest points within the area between the building and the lot line or where the lot line is

more than 6 feet from the building, use the reference point between the structure and a point 6 feet from the building.

4. Measurements shall be taken at the existing grade or finished grade, whichever is lower.
5. Depressions such as window wells, stairwells for exits required by other codes, “barrier free” ramps on grade, and vehicle access driveways into garages shall be disregarded in determining structure height when in combination they comprise less than fifty percent of the facade on which they are located. In such cases, the grade for height measurement purposes shall be a line between the grades on either side of the depression.

FIGURE 17C.110.230-A: Height Measurement

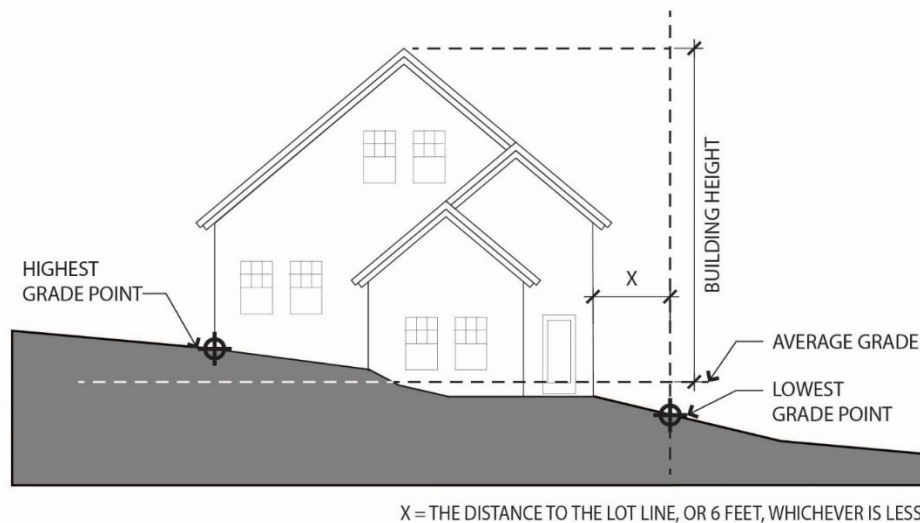

Figure 17C.111.230-A Height Measurement

6. For purposes of measuring building height in residential zones, the following terms shall be interpreted as follows:
 - a. “Grade” means the ground surface contour (see also “existing grade” and “finished grade”).
 - b. “Fill” means material deposited, placed, pushed, pulled or transported to a place other than the place from which it originated.

- c. "Finished grade" means the grade upon completion of the fill or excavation.
- d. "Excavation" means the mechanical removal of earth material.
- e. "Existing grade" means the natural surface contour of a site, including minor adjustments to the surface of the site in preparation for construction.

C. Exceptions to the maximum height standard are stated below:

- 1. Exceptions to the maximum structure height in the RMF and RHD zones are designated on the official zoning map by a dash and a height listed after the zone map symbol (i.e., RHD-150). Changes to the height limits in the RMF and RHD zones require a rezone. Height limits are forty feet, fifty-five feet, (~~seventy feet~~) seventy-five feet, or one hundred fifty feet depending on location.

~~((2. In RMF and RHD zones where the maximum structure height is forty feet, pitched roof structures are allowed an additional fifteen feet above the maximum height standard stated in Table 17C.111.205-2, provided that the roof incorporates all of the following:~~

- ~~a. pitched roof forms having slopes between 4:12 and 12:12; and~~
- ~~b. a minimum of one roof plane that intersects the maximum height plane (see Figure 17C.111.230-B for eligible examples); and~~
- ~~c. establishes sense of "top" per SMC 17C.111.455.))~~

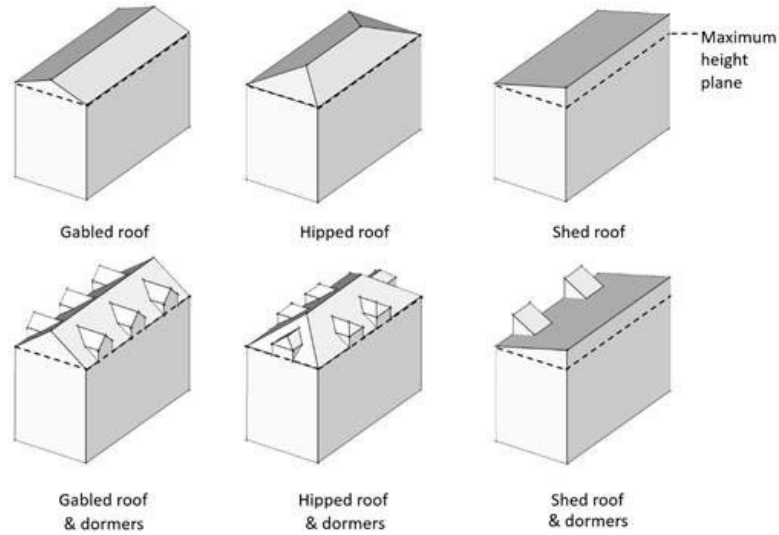

~~((Figure 17C.111.230-B: Roof Type Examples for Height Exception))~~

[NOTE: Delete graphic above]

~~((3))~~ 2. In the RMF and RHD zones, height does not include up to three feet of the above-grade portions of basement parking, where the elevation of the first residential finished floor is three feet or less above the lowest elevation of the existing grade or finished grade, whichever is lower. See Figure ~~((17C.111.230-C))~~ 17C.111.230-B.

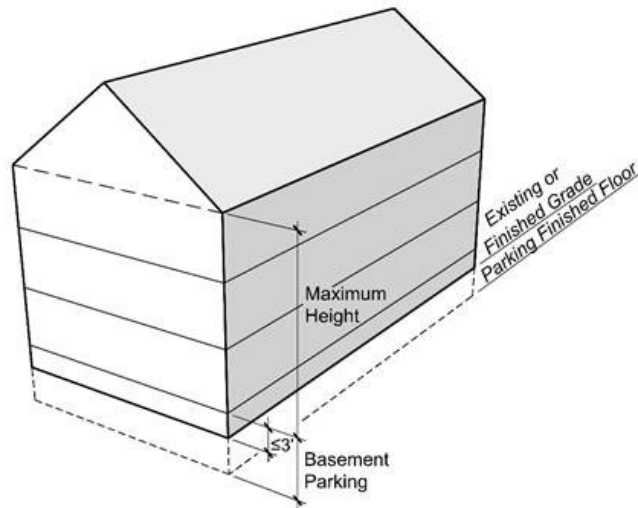

Figure ~~((17C.111.230-C))~~ 17C.111.230-B: Basement Parking Excluded from Height

~~((4))~~3. Buildings and structures over fifty feet in height must follow the design, setback and dimensional standards found in [chapter 17C.250 SMC](#), Tall Building Standards

~~((5))~~4. Adjacent to R1 and R2 Zones.

To provide a gradual transition and enhance the compatibility between the more intensive commercial zones and adjacent R1 and R2 residential zones:

a. For all development within ~~((one hundred fifty))~~ forty feet of any R1 or R2 residential zone the maximum building height is as follows:

i. Starting at a height of ~~((thirty))~~ forty feet ~~((the residential zone boundary))~~ at R1 and R2 property boundaries, additional building height may be added at a ratio of ~~((one))~~ 2 to ~~((two))~~ 1 ~~((one-foot))~~ two feet of additional building height for every ~~((two feet))~~ one foot of additional horizontal distance from the closest ~~((single-family))~~ R1 or ~~((two-family))~~ R2 ~~((residential-zone))~~ zoned property. ~~((The building height transition requirement ends one hundred fifty feet from the R1 or R2 residential zone and then full building height allowed in the zone applies.))~~

ii. The building height transition requirement ends forty feet from the R1 or R2 zoned property line and then full building height allowed in the zone applies.

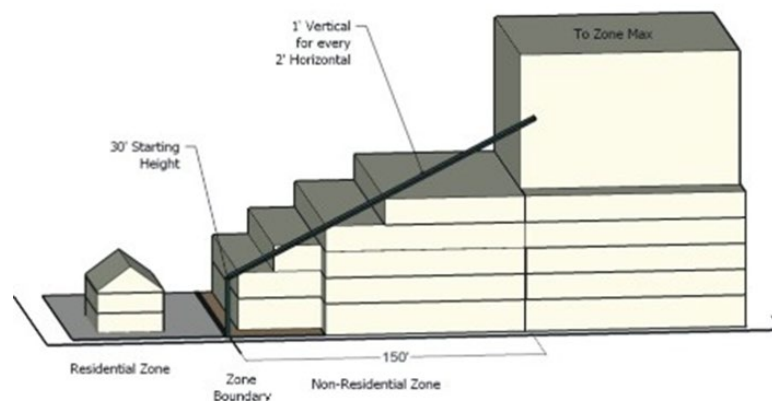

[NOTE: Delete graphic above]

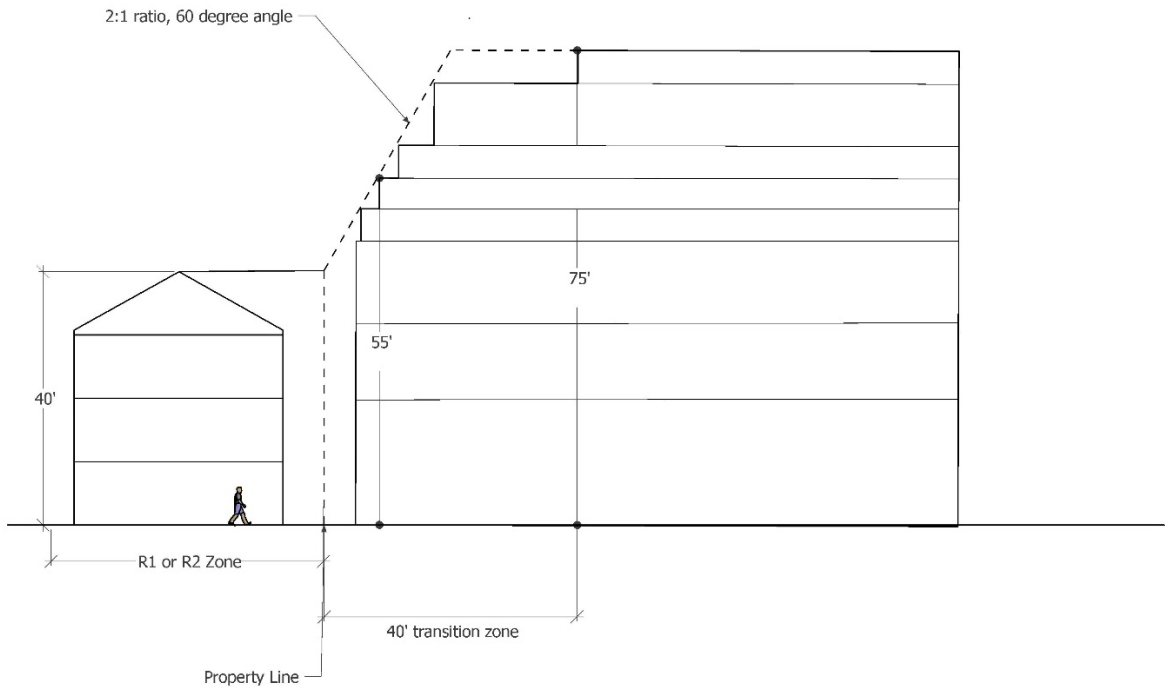

Figure 17C.111.230-C: Height Transition

~~((6. In the RMF zone within forty feet of a common boundary with a R1 zone, the maximum height is forty feet.))~~

~~((7))~~ 5. Projections Allowed.

Chimneys, flagpoles, satellite receiving dishes and other similar items with a width, depth or diameter of three feet or less may extend above the height limit, as long as they do not exceed three feet above the top of the highest point of the roof. If they are greater than three feet in width, depth or diameter, they are subject to the height limit.

~~((8))~~ 6. In addition to the projections allowed under subsection (7) above, in the RMF and RHD zones, the following projections above the roof height are allowed:

- a. Parapets and rooftop railings may extend four feet above the height limit.
- b. Walls or fences located between individual rooftop decks may extend six feet above the height limit if the wall or fence is set back at least four feet from the edges of the roof.

- c. Stairway enclosures that provide rooftop access and cumulatively cover no more than ten percent of the roof area may extend up to ten feet above the height limit, provided that the enclosures are setback at least fifteen feet from all roof edges on street facing facades.

~~((9))~~7. Farm Buildings.

Farm buildings such as silos, elevators and barns are exempt from the height limit as long as they are set back from all lot lines at least one foot for every foot in height.

- ~~((10))~~8. Utility power poles and public safety facilities are exempt from the height limit.

- ~~((11))~~9. Radio and television antennas are subject to the height limit of the applicable zoning category.

- ~~((12))~~10. Wireless communication support towers are subject to the height requirements of [chapter 17C.355A SMC](#), Wireless Communication Facilities.

- ~~((13))~~11. Uses approved as a conditional use may have building features such as a steeple or tower which extends above the height limit of the underlying zone. Such building features must set back from the side property line adjoining a lot in a residential zone a distance equal to the height of the building feature or one hundred fifty percent of the height limit of the underlying zone, whichever is lower.

D. Special Height Districts.

Special height districts are established to control structure heights under particular circumstances such as preservation of public view or airport approaches. See [chapter 17C.170 SMC](#), Special Height Overlay Districts.

E. Accessory Structures.

The height of any accessory structure located in the rear yard, including those attached to the primary residence, is limited to twenty feet in height, except a detached ADU above a detached accessory structure may be built to twenty-five (25) feet in height.

Section 2. That SMC Section 17C.120.220 be amended to read as follows:

17C.120.220 Height

A. Purpose

The height limits are intended to control the overall scale of buildings. The height limits in the O, NR and NMU zones discourage buildings that visually dominate adjacent residential areas. The height limits in the OR, CB and GC zones allow for a greater building height at a scale that generally reflects Spokane's commercial areas. Light, air and the potential for privacy are intended to be preserved in single-family residential zones that are close to commercial zones.

B. Height Standards

The height standards for all structures are stated in [Table 17C.120-2](#). Exceptions to the maximum height standard are stated below.

1. Maximum Height.

Exceptions to the maximum structure height are designated on the official zoning map by a dash and a height listed after the zone map symbol (i.e., CB-150). Changes to the height limits require a rezone. Height limits are ~~((thirty-five feet,))~~ forty feet, fifty-five feet, ~~((seventy feet))~~ seventy-five feet, or one hundred fifty feet depending on location.

2. Buildings and structures over fifty feet in height must follow the design, setback and dimensional standards found in [chapter 17C.250 SMC](#), Tall Building Standards.

3. Adjacent to ~~((Single-family))~~ R1 and ~~((Two-family Residential))~~ R2 Zones.

To provide a gradual transition and enhance the compatibility between the more intensive commercial zones and adjacent ~~((single-family))~~ R1 and ~~((two-family))~~ R2 residential zones:

a. For all development within one hundred fifty feet of ~~((any single-family or two-family residential zone))~~ R1 or R2 zoned properties the maximum building height is as follows:

i. Starting at a height of ~~((thirty))~~ forty feet at ~~((the residential zone boundary))~~ R1 and R2 property boundaries, additional building height may be added at a ratio of ~~((4))~~ 2 to ~~((2))~~ 1 ~~((one-foot))~~ two feet of additional building height for every ~~((two-feet))~~ one foot of additional horizontal distance from the closest ~~((single-family))~~ R1 or ~~((two-family))~~ R2 ~~((residential zone))~~ zoned property line. ~~((The building height transition~~

requirement ends one hundred fifty feet from the single-family or two-family residential zone and then full building height allowed in the zone applies.))

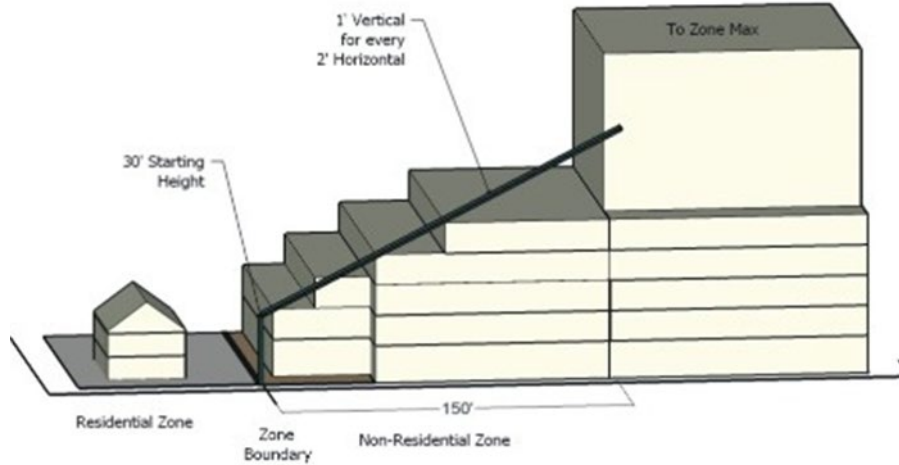

[NOTE: Delete graphic above]

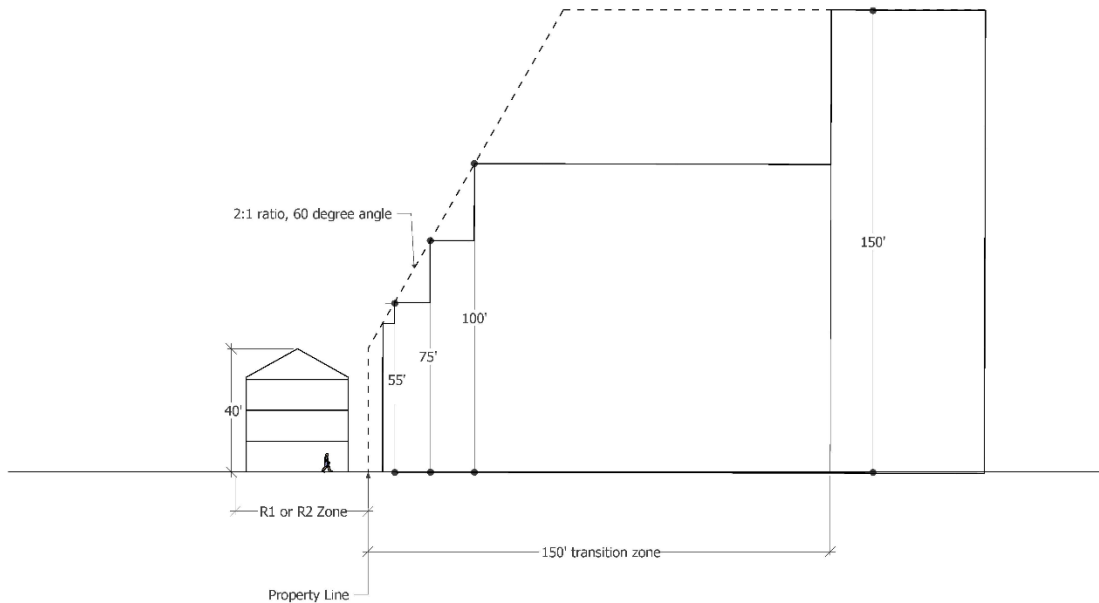

Figure 17C.120.220: Height Transition

4. Projections Allowed.

Chimneys, flag poles, satellite receiving dishes, and other similar items with a width, depth or diameter of five feet or less may rise ten feet above the height limit, or five feet above the highest point of the roof, whichever is greater. If they are greater than five feet in width, depth or diameter, they are subject to the height limit.

5. Rooftop Mechanical Equipment.

All rooftop mechanical equipment must be set back at least fifteen feet from all roof edges that are parallel to street lot lines. Elevator mechanical equipment may extend up to sixteen feet above the height limit. Other rooftop mechanical equipment which cumulatively covers no more than ten percent of the roof area may extend ten feet above the height limit.

6. Radio and television antennas, utility power poles, and public safety facilities are exempt from the height limit except as provided in chapter 17C.355A SMC, Wireless Communication Facilities.

C. Special Height Districts

Special height districts are established to control structure heights under particular circumstances such as preservation of public view or airport approaches. See [chapter 17C.170 SMC](#), Special Height Overlay Districts.

17C.122 CENTER & CORRIDOR TEXT AMENDMENTS

The proposed Spokane Municipal Code Text Amendments related to Center and Corridor zoning are citywide and not limited to the South Logan Project Area. The citywide changes implement recommendations from the [South Logan TOD Plan](#), with citywide implementation ensuring consistency. The South Logan TOD Plan anticipated [Section 17C.400.040 Pilot Center and Corridors Development Standards](#) would be made permanent. As an interim ordinance, the purpose is to identify which regulations should be kept and which should be adjusted or removed. The proposed regulations make permanent, with adjustments informed by the pilot period and through analysis from the [Centers and Corridors Study](#), the interim citywide regulations. The proposal includes adjusting height standards, not permitting drive-thrus in the CC1 zone or along Pedestrian Street designations, implementing height bonuses instead of FAR bonuses, modifying parking requirements, as well as consolidation and reorganization for improved useability.

Text with (~~strikethrough~~) is proposed to be repealed/modified with underlined text representing proposed text. Text without a strikethrough or underline is existing and not proposed to be modified.

The proposed Center & Corridor text amendments also include a number of new sections, largely due to reorganization. These sections do not include strikethrough or underlined text. These new sections and proposed changes are noted in the text amendment tracking sheet.

Section 1. That SMC Section 17C.122.070 Center and Corridor Zone Allowed Uses is amended to read as follows:

Section 17C.122.070 Center and Corridor Zone Allowed Uses

~~((The uses allowed in the center and corridor zones are shown in Chapter 17C.122T Center and Corridor Zone Development Tables: Table 17C.122.070-1 Center and Corridor Zone Allowed Uses.))~~

The uses allowed in the Center and Corridor zones are shown in Table 17C.122.070-1.

TABLE 17C.122.070-1 CENTER AND CORRIDOR ZONE ALLOWED USES			
<u>Use is:</u> <u>P</u> – Permitted <u>N</u> – Not Permitted <u>L</u> – Allowed, but special limitations <u>CU</u> – Conditional use review required	<u>CC Zone Type</u>		
	<u>Core Zones</u>	<u>Transition Zone</u>	
	<u>CC1</u>	<u>CC2</u>	<u>CC4</u>
<u>Residential</u>	<u>P</u>	<u>P</u>	<u>P</u>
<u>Hotels, including Bed and Breakfast Inns</u>	<u>P</u>	<u>P</u>	<u>N</u>
<u>Commercial, Financial, Retail, Personal Services</u>	<u>P[1]</u>	<u>P[1]</u>	<u>L[4]</u>
<u>Eating and Drinking Establishments</u>	<u>P[2]</u>	<u>P[2]</u>	<u>N</u>

<u>Restaurants without Cocktail Lounges</u>	<u>P</u>	<u>P</u>	<u>L[4]</u>
<u>Professional and Medical Offices</u>	<u>P</u>	<u>P</u>	<u>L[4]</u>
<u>Entertainment, Museum and Cultural</u>	<u>P</u>	<u>P</u>	<u>N</u>
<u>Government, Public Service or Utility Structures, Social Services and Education</u>	<u>P</u>	<u>P</u>	<u>P</u>
<u>Religious Institutions</u>	<u>P</u>	<u>P</u>	<u>P</u>
<u>Parks and Open Space</u>	<u>P</u>	<u>P</u>	<u>P</u>
<u>Surface Lot Commercial Parking</u>	<u>N</u>	<u>N</u>	<u>N</u>
<u>Structured Commercial Parking*</u>	<u>P</u>	<u>P</u>	<u>P</u>
<u>Public Parking Lot</u>	<u>P</u>	<u>P</u>	<u>N</u>
<u>Limited Industrial (if entirely within a building)</u>	<u>P[3]</u>	<u>P[3]</u>	<u>N</u>
<u>Heavy Industrial</u>	<u>N</u>	<u>N</u>	<u>N</u>
<u>Drive-through Businesses</u>	<u>N</u>	<u>P[5]</u>	<u>P[5]</u>
<u>Motor Vehicles Sales, Rental, Repair or Washing</u>	<u>N</u>	<u>P</u>	<u>N</u>
<u>Automotive Parts and Tires (with exterior storage or display)</u>	<u>N</u>	<u>P</u>	<u>N</u>
<u>Gasoline Sales (serving more than six vehicles)</u>	<u>N</u>	<u>P</u>	<u>N</u>
<u>Gasoline Sale (serving six vehicles or less)</u>	<u>P</u>	<u>P</u>	<u>P</u>
<u>Self-storage or Warehouse</u>	<u>N</u>	<u>P</u>	<u>N</u>
<u>Adult Business (subject to chapter 17C.305 SMC special provisions)</u>	<u>N</u>	<u>N</u>	<u>N</u>
<u>Winery and Microbreweries</u>	<u>P</u>	<u>P</u>	<u>N</u>
<u>Mobile Food Vending</u>	<u>P[6]</u>	<u>P[6]</u>	<u>P[6]</u>
<u>Notes:</u> <u>[1] Retail uses having more than forty thousand gross floor area are not permitted in neighborhood centers designated by the comprehensive plan.</u> <u>[2] Eating and drinking establishments larger than five thousand gross floor area are not permitted in neighborhood centers designated by the comprehensive plan.</u> <u>[3] Limited industrial uses having more than twenty thousand gross floor area are not permitted in neighborhood centers designated by the comprehensive plan.</u> <u>[4] Residential uses are required to be mixed on the same parcel as proposed office and retail uses. Nonresidential uses are limited to three thousand square feet per parcel. In neighborhood centers, nonresidential uses are only allowed on parcels with frontage on an arterial street. Nonresidential uses in the CC4 zone are not allowed within sixty feet of a single-family and two-family residential zone or further than three hundred feet (neighborhood center only) from a CC core comprehensive plan designation.</u> <u>[5] Drive-through businesses are not permitted along designated Pedestrian Streets</u> <u>[6] All mobile food vendors shall have a valid mobile food vending license issued pursuant to SMC 10.51.010.</u>			

Section 2. That SMC Section 17C.122.080 Floor Area Ratio (FAR) is repealed.

Section 3. That SMC Section 17C.122.090 is amended to read as follows:

Section 17C.122.090 Public Amenities Allowing Bonus ((FAR)) Height

~~((A. Minor Amenities.~~

~~Each public amenity from the following list may allow an increase of two-tenths FAR from the basic allowable FAR to the maximum FAR.~~

~~1. Additional Streetscape Features.~~

~~Seating, trees, pedestrian-scaled lighting and special paving in addition to any that are required by the design standards and guidelines.~~

~~2. Canopy Over the Public Sidewalk.~~

~~A virtually continuous canopy structure. A canopy is a permanent architectural element projecting out from a building facade over a sidewalk or walkway. A canopy shall be at least five feet in horizontal width and be no less than eight feet and no more than twelve feet above grade.~~

~~3. Alley Enhancements.~~

~~Decorative paving, pedestrian-scaled lighting, special paving and rear entrances intended to encourage pedestrian use of the alley.~~

~~4. Preferred Materials on Building.~~

~~Use of brick and stone on the building facades that face streets.~~

~~5. An amenity specifically identified and described in an adopted neighborhood plan.~~

~~6. Building to the Street.~~

~~Buildings complying with the “Buildings Along the Street” design guidelines (page 4 of the center and corridor design guidelines) so that at least fifteen percent of the frontage of the site consists of building facades.~~

~~B. Major Amenities.~~

~~Each public amenity from the following list may allow an increase of five-tenths FAR from the basic allowable FAR to the maximum FAR.~~

~~1. Exterior Public Space(s).~~

~~A plaza or courtyard, with a minimum area of four hundred square feet or two percent of the total interior floor space of the development, whichever is greater. A plaza or a courtyard is a level space accessible to the public, at least ten feet in width, with a building façade on at least one side. The elevation of the courtyard or plaza shall be within thirty inches of the grade of the sidewalk providing access to it. For courtyards, at least sixty percent of the green shall be planted with trees, ground cover and other vegetation. For plazas, at least fifteen percent, but no more than sixty~~

~~percent of the space shall be planted with trees, ground cover and other vegetation. Courtyards and plazas shall also include seating, pedestrian-scale lighting, decorative paving and other pedestrian furnishings. The use of artists to create fixtures and furnishings is strongly encouraged.~~

~~2. Public Art.~~

~~Public art includes sculptures, murals, inlays, mosaics and other two-dimensional or three-dimensional works, as well as elements integrated into the design of a project (e.g, fountain) that are designed and crafted by one or more artists. Such artists must be listed on a registry of either the Washington state arts commission or the Spokane arts commission. To receive the FAR bonus, public art must be documented at a value that is at least one percent of the value of construction.~~

~~3. Through block pedestrian connection providing a continuous walkway accessible to the public, at least ten feet in width, paved with decorative paving and lighted for nighttime use. It may be covered or open to the sky.~~

~~4. Residential Units.~~

~~Comprising at least twenty five percent of the total floor area.~~

~~5. Structured parking.~~

~~6. If all of the standards and guidelines for Type 1 centers and pedestrian streets are incorporated into a project that is within a Type 2 center.~~

~~C. "Super Bonuses."~~

~~Any development that receives super bonuses shall also provide at least two of the major or minor amenities listed above. In return for providing either of the following, the maximum FAR's may be increased by fifty percent.~~

~~1. Underground Parking.~~

~~All of the parking is provided within a structure that is entirely below grade.~~

~~2. Affordable Housing.~~

~~At least twenty percent of the units are set aside for households making less than eighty percent of the median income for the City as defined by HUD.))~~

A. Development that meets the following conditions may be allowed an additional fifteen feet of height to the maximum height standards in Section 17C.122.200 Development Standards Table.

1. Underground Parking.

a. All off-street parking provided on the site meets one of the following conditions:

- i. Parking areas are entirely below the grade of any adjacent streets; or
- ii. Surface parking or structured parking at ground level is located entirely behind buildings relative to all adjacent streets; or
- iii. Structured parking visible from the street is above ground level with non-parking uses lining the street.

2. Affordable Housing.

- a. At least twenty percent of the residential units are set aside for households making less than eighty percent of the Spokane County Area Median Income as defined by the United States Department of Housing and Urban Development.

3. Public Art.

- a. May include sculptures, murals, inlays, mosaics, and other two-dimensional or three-dimensional works, as well as elements integrated into the design of a project (e.g., fountain) that are designed and crafted for the aesthetic improvement of the pedestrian realm.

- i. To receive the height bonus, public art must be documented at a value that is at least one percent of the value of construction.

Section 4. That SMC Section 17C.122.100 Maximum Building Height is repealed.

Section 5. That SMC Section 17C.122.110 Setbacks and Required Sidewalk Width is repealed.

Section 6. That there is adopted a new Section 17C.122.200 to Chapter 17C.122 SMC to read as follows:

Section 17C.122.200 Development Standards Table

Development standards that apply within Center and Corridor Zones are provided in Table 17C.122.200-2 Center and Corridor Development Standards

Table 17C.122.200-2 Center and Corridor Development Standards			
HEIGHT STANDARDS			
	CC1	CC2	CC4
Neighborhood Center	55 ft [1][2]	55ft [1][2]	55ft [1][2]

District Center or Corridor		75 ft [1][2]	75 ft [1][2]	55 ft [1][2]
Employment Center		150 ft [2]	150 ft [2]	75 ft [2]
FLOOR AREA RATIO (FAR) STANDARDS				
		CC1	CC2	CC4
Neighborhood Center	Minimum FAR	No Minimum	No Minimum	No Minimum
	Maximum FAR	No Maximum	No Maximum	No Maximum
District Center	Minimum FAR	0.5	0.5	0.5
	Maximum FAR	No Maximum	No Maximum	No Maximum
Employment Center	Minimum FAR	1	1	1
	Maximum FAR	No Maximum	No Maximum	No Maximum
SETBACK STANDARDS				
		CC1	CC2	CC4
Minimum setback from street lot line		0 ft.	0 ft.	0 ft. (([3]))
Minimum setback from R1 and R2 zoned lots		10 ft. (((-4)) [3])	10 ft. (((-4)) [3])	10 ft. (((-4)) [3])
Minimum setback from all zones except R1 and R2		0 ft. (((-4)) [3])	0 ft. (((-4)) [3])	0 ft. (((-4)) [3])
LOT DIMENSIONS				
		CC1	CC2	CC4
Minimum front lot line width		10 ft.	10 ft.	10 ft.
<p>[1] An additional fifteen ft of height is permitted provided that at least one condition under Section 17C.122.090 Public Amenities Allowing Additional Height is met.</p> <p>[2] Structures over seventy feet in height must follow the standards in Chapter 17C.250 Tall Building Standards.</p> <p>[3] (When abutting R1 and R2 zoned lots, the minimum structure setback from street lot line is the same as the abutting residential zoning district for the first 60 ft. from the boundary of the abutting residential zoning district. See SMC 17C.120.230 for additional standards and exceptions. This does not apply when a zone boundary is within the public right-of-way.)</p> <p>(((4))) Structure setbacks are measured from the lot line.</p>				

Section 7. That there is adopted a new Section 17C.122.210 to Chapter 17C.122 SMC to read as follows:

Section 17C.122.210 Height

A. Height.

The maximum height standards for all structures are stated in Table 17C.122.200-2. The building height shall be measured using the following method (see Figure 17C.122.210-A):

1. Building height is the vertical distance from the average grade to the highest point of the roof or structure.
2. Underground portions of the structure are not included in height calculations. The height of the structure shall be calculated from the point at which the sides meet the surface of the ground.
3. "Average grade" means the average of the ground level adjoining the building at all exterior walls. Where the ground level slopes away from the exterior walls, the reference point shall be established by the lowest points within the area between the building and the lot line or where the lot line is more than 6 feet from the building, use the reference point between the structure and a point 6 feet from the building.
4. Measurements shall be taken at the existing grade or finished grade, whichever is lower.
5. Depressions such as window wells, stairwells for exits required by other codes, "barrier-free" ramps on grade, and vehicle access driveways into garages shall be disregarded in determining structure height when in combination they comprise less than fifty percent of the facade on which they are located. In such cases, the grade for height measurement purposes shall be a line between the grades on either side of the depression.
6. Public amenities allowing additional height can be found in Section 17C.122.090 Public Amenities Allowing Bonus Height.
7. For buildings over 70 feet tall, Chapter 17C.250 Tall Building Standards apply.

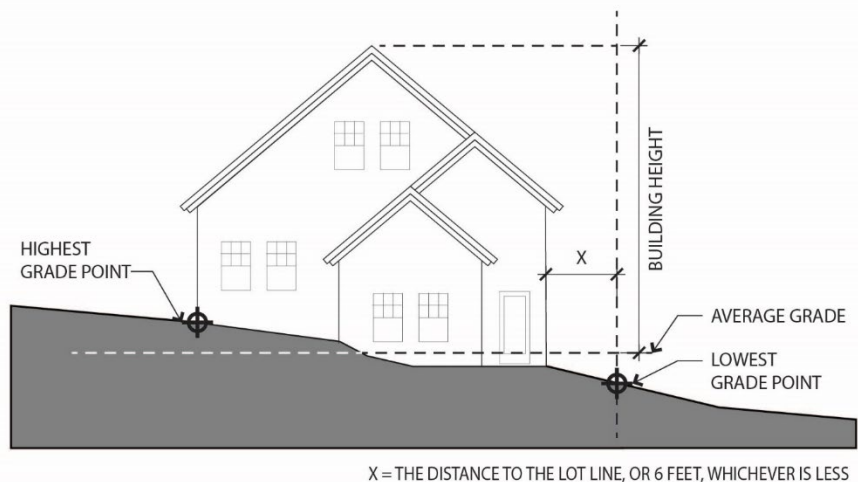

Figure 17C.122.210-A

Section 8. That there is adopted a new Section 17C.122.220 to Chapter 17C.122 SMC to read as follows:

Section 17C.122.220 Height Transition

A. Purpose.

The following exception to the maximum building height standards is to provide a gradual transition and enhance the compatibility between the more intensive center zones and adjacent low and moderate residential zones.

B. Applicability.

For all development adjacent to R1 or R2 zoned properties the maximum building height is as follows:

1. Starting at a height of 40 ft. at R1 and R2 property boundaries, additional building height may be added at a ratio of 2 to 1 (two feet of additional building height for every one foot of additional horizontal distance from the closest R1 or R2 zoned property line).
2. The building height transition requirement ends 150 ft. from the R1 or R2 zoned property line. Beyond the transition, the maximum building height of the zone applies.

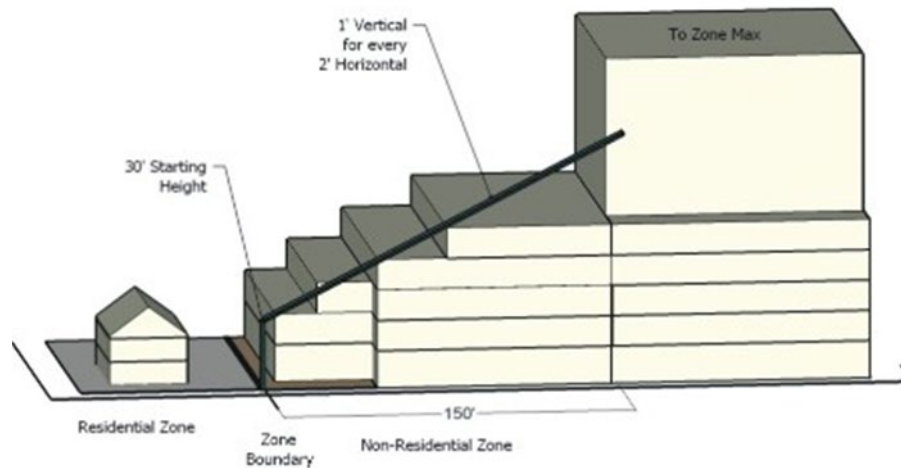

[NOTE: Delete graphic above]

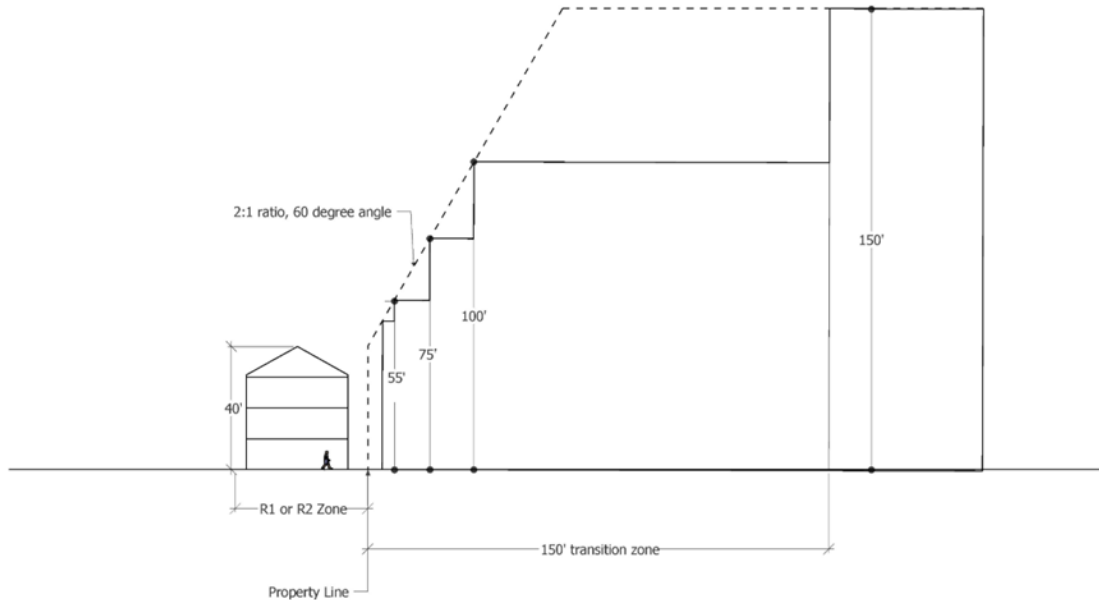

Figure 17C.122.220-A: Height Transition

Section 9. That there is adopted a new Section 17C.122.230 to Chapter 17C.122 SMC to read as follows:

Section 17C.122.230 Floor Area Ratio

A. Floor Area Ratio (FAR).

FAR standards are stated in Table 17C.122.200-2. FAR is the measurement of the building's gross floor area in relation to the size of the lot. A structure that has the same gross floor area as the area of the lot is considered to have a FAR of 1, if the structure has half the gross floor area as the area of the lot the FAR is 0.5. In addition to other dimensional standards FAR is used to ensure the intensity of the structure is appropriate to the zoning.

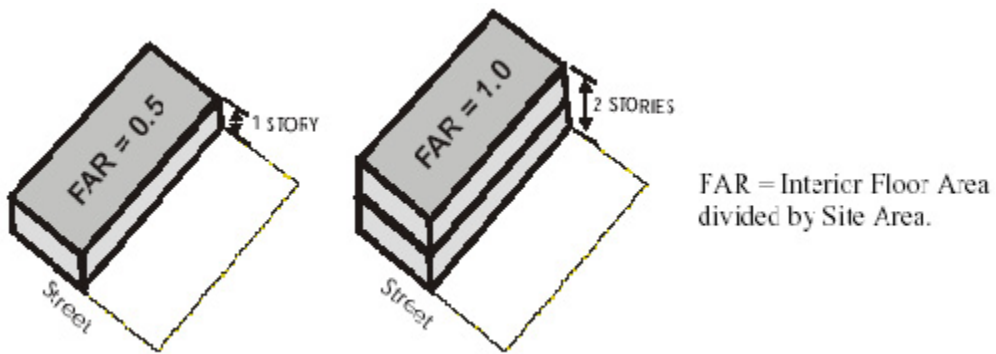

Section 10. That there is adopted a new Section 17C.122.240 to Chapter 17C.122 of the Spokane Municipal Code that SMC to read as follows:

Section 17C.122.240 Setbacks

A. Setbacks.

Setback Standards are stated in Table 17C.122.200-2. Setbacks in Centers and Corridors ensure that there is adequate space between the structure's facade and the street allowing for ample space for the pedestrian realm.

1. The minimum setback from street lot lines is zero feet and buildings shall be no closer than twelve feet from the back of the curb except as provided in 17C.122.240(A)(2).
2. This width may be reduced, by approval of the Planning Director, if the existing sidewalk is less than twelve feet wide between the back of the curb and the existing building setback line of the adjacent building(s). In no case shall the setback be reduced below nine feet from the back of the curb.

Section 11. That there is adopted a new Section 17C.122.250 to Chapter 17C.122 SMC to that read as follows:

Section 17C.122.250 Sidewalks

A. Sidewalks.

1. Sidewalks shall be at least twelve feet wide and consist of a clear walking path at least seven feet wide (in addition to a planting zone for street trees per SMC 17C.200.050) except as provided in 17C.122.240(A)(2).

Section 12. That Chapter 17C.122T entitled "Center and Corridor Zone Development Tables" is repealed.

Section 13. That SMC Section 17C.230.120 is amended to read as follows:

Section 17C.230.120 Maximum Required Parking Spaces

A. Purpose.

Limiting the number of spaces allowed promotes efficient use of land, enhances urban form, encourages use of alternative modes of transportation, provides for better pedestrian movement, and protects air and water quality. The maximum ratios in this section vary with the use the parking it is accessory to. These

maximums will accommodate most auto trips to a site based on typical peak parking demand for each use.

B. Maximum Number of Parking Spaces Allowed.

Standards in a plan district or overlay zone may supersede the standards in this subsection.

1. Surface Parking.

The maximum number of parking spaces allowed is stated in Table 17C.230.120-1 and Table 17C.230.130-1, except as specified in subsection (B)(2) of this section.

2. Structure Parking.

Parking provided within a building or parking structure is not counted when calculating the maximum parking allowed.

TABLE 17C.230.120-1 PARKING SPACES BY ZONE [1] (Refer to Table 17C.230.130-1 for Parking Spaces Standards by Use)		
ZONE	SPECIFIC USES	REQUIREMENT
RA, R1, R2, RMF, RHD	All Land Uses	Minimum and maximum standards are shown in Table 17C.230.130-1 .
O, OR, NR, NMU, CB, GC, Industrial		
CG1, CG2, CG3 [2]	Nonresidential	Minimum ratio is 1 stall per 1,000 gross square feet of floor area. Maximum ratio is 4 stalls per 1,000 gross square feet of floor area.
	Residential	Minimum ratio is 1 stall per 1,000 gross square feet of floor area or a minimum of 1 stall per dwelling unit plus one per bedroom after 3 bedrooms. Maximum ratio is the same as for nonresidential uses.
CG4 [2]	Nonresidential	Minimum ratio is 2 stalls per 1,000 gross square feet of floor area.

		Maximum ratio is 4 stalls per 1,000 gross square feet of floor area.
	<u>Residential</u>	Minimum ratio is 1 stall per 1,000 gross square feet of floor area or a minimum of 1 stall per dwelling unit, whichever is less. Maximum ratio is the same as for nonresidential uses.))
<u>CC1, CC2, CC3, CC4 [2]</u>	<u>Nonresidential</u>	<u>There is no minimum parking requirement. Maximum ratio is 4 stalls per 1,000 gross square feet of floor area.</u>
	<u>Residential</u>	<u>There is no minimum parking requirement. Maximum ratio is 4 stalls per 1,000 gross square feet of floor area.</u>
Downtown [2]	((All Land Uses)) <u>Nonresidential</u>	((See the Downtown Parking Requirement Map 17C.230-M1 to determine if parking is required. - Minimum ratio for areas shown on the map that require parking is 1 stall per 1,000 gross square feet of floor area or a minimum of 1 stall per dwelling unit, whichever is less.)) <u>There is no minimum parking requirement.</u> Maximum ratio is 3 stalls per 1,000 gross square feet of floor area.
	<u>Residential</u>	<u>There is no minimum parking requirement. Maximum ratio is 3 stalls per 1,000 gross square feet of floor area.</u>
FBC [2]	All Land Uses	See SMC 17C.123.040 , Hamilton Form Based Code for off-street parking requirements.
Overlay	All Land Uses	No off-street parking is required. See the No Off-Street Parking Required Overlay Zone Map 17C.230-M2 and No Off-Street Parking Required Overlay Zone Map 17C.230-M3 .

[1] Standards in a plan district or overlay zone may supersede the standards of this table.

[2] See exceptions in [SMC 17C.230.130](#), CC and Downtown Zone Parking Exceptions.

Section 14. That SMC Section 17C.230.130 is amended to read as follows:

Section 17C.230.130 Parking Exceptions

- A. In (~~center and corridor downtown, and FBC CA1, CA2, and CA3 zones any new building or building addition with a floor area less than three thousand square feet shall have no parking requirement~~), all Center and Corridor zones, all Downtown zones, and all Form-Based Code no parking is required.
- B. In the (~~neighborhood retail~~) Neighborhood Retail zone, any existing building, new building, or building addition, having a floor area less than three thousand square feet shall have no parking requirement. In addition, if a building has a floor area of five thousand square feet or less, the parking requirement will be determined after deducting the three thousand square foot exemption from the building's floor area. For example, the parking requirement for a four thousand square foot building would be based on one thousand square feet of floor area – i.e., a four thousand square foot building size minus the three thousand square foot exemption.
- C. The Planning Director may approve ratios that are higher than the maximum or lower than the minimum if sufficient factual data is provided to indicate that a different amount is appropriate. The applicant assumes the burden of proof. Approval of parking above the maximum shall be conditioned upon increasing the amount of required landscaping by thirty percent. Approval of parking below the minimum shall be conditioned upon the project contributing towards a pedestrian and transit supportive environment both next to the immediate site and in the surrounding area. When determining if a different amount of parking is appropriate, the Director shall consider the proximity of the site to frequent transit service, the intensity of the zoning designation of the site and surrounding sites, and the form of the proposed use.
- D. If property owners and businesses establish a parking management area program with shared parking agreements, the Planning Director may reduce or waive parking requirements.
- E. Existing legal nonconforming buildings that do not have adequate parking to meet the standards of this section are not required to provide off-street parking when remodeling which increases the amount of required parking occurs within the existing structure.
- F. Attached Housing.

The following exceptions apply only to attached housing (defined in SMC 17A.020.010) in the RMF and RHD zones. Distances are measured in a straight line between the zone/overlay boundary to the lot line of the site containing the development.

1. On a lot at least partially within one thousand three hundred twenty feet of CC, CA, or DT zone or CC3 zoning overlay, the minimum number of off-street vehicle parking spaces required is fifty percent less than the minimum required for Residential Household Living in Table 17C.230.130-1.
 2. On a lot farther than one thousand three hundred twenty feet of a CC, CA, or DT zone or CC3 zoning overlay, the minimum number of off-street vehicle parking spaces required is thirty percent less than the minimum required for Residential Household Living in Table 17C.230.130-1.
- G. Parking is not required for residential development on sites located within one-half mile of a transit stop.

TABLE 17C.230.130-1 PARKING SPACES BY USE [1] (Refer to Table 17C.230.120-1 for Parking Space Standards by Zone) CU = Conditional Use			
RESIDENTIAL CATEGORIES			
USE CATEGORIES	SPECIFIC USES	MINIMUM PARKING	MAXIMUM PARKING
Group Living		1 per 4 residents	None
<u>Residential Household Living within one-half mile of a transit stop</u>		<u>None</u>	<u>None</u>
Residential Household Living <u>outside of one-half mile of a transit stop</u> [2] [3]		((1 per unit plus 1 per bedroom after 3 bedrooms [3]; Accessory Dwelling Unit (ADU)—see Note [4]; Single Resident Occupancy (SRO) are exempt)) <u>On lots smaller than 6,000 square feet, only</u>	None

		<p><u>one parking space per unit is required regardless of bedroom count.</u></p> <p><u>On lots 6,000 square feet or larger, each unit with 3 or fewer bedrooms shall provide one parking space per unit and each unit with 4 or more bedrooms shall provide a minimum of two parking spaces per unit.</u></p>	
--	--	--	--

COMMERCIAL CATEGORIES

USE CATEGORIES	SPECIFIC USES	MINIMUM PARKING	MAXIMUM PARKING
Adult Business		1 per 500 sq. ft. of floor area	1 per 200 sq. ft. of floor area
Commercial Outdoor Recreation		20 per acre of site	30 per acre of site
Commercial Parking		Not applicable	None
Drive-through Facility		Not applicable	None
Major Event Entertainment		1 per 8 seats or per CU review	1 per 5 seats or per CU review
Office	General Office	1 per 500 sq. ft. of floor area	1 per 200 sq. ft. of floor area
	Medical/Dental Office	1 per 500 sq. ft. of floor area	1 per 200 sq. ft. of floor area
Quick Vehicle Servicing		1 per 500 sq. ft. of floor area	1 per 200 sq. ft. of floor area
Retail Sales and Service	Retail, Personal	1 per 330 sq. ft. of floor area	1 per 200 sq. ft. of floor area

	Service, Repair-oriented		
	Restaurants and Bars	1 per 250 sq. ft. of floor area	1 per 60 sq. ft. of floor area
	Health Clubs, Gyms, Lodges, Meeting Rooms and similar continuous entertainment, such as Arcades and Bowling Alleys	1 per 330 sq. ft. of floor area	1 per 180 sq. ft. of floor area
	Temporary Lodging	1 per rentable room; for associated uses such as Restaurants, see above	1.5 per rentable room; for associated uses such as Restaurants, see above
	Theaters	1 per 4 seats or 1 per 6 feet of bench area	1 per 2.7 seats or 1 per 4 feet of bench area
	Retail sales and services of large items, such as appliances, furniture and equipment	1 per 1,000 sq. ft. of floor area	1 per 200 sq. ft. of floor area
Mini-storage Facilities		Same as Warehouse and Freight Movement	Same as Warehouse and Freight Movement
Vehicle Repair		1 per 750 sq. ft. of floor area	1 per 200 sq. ft. of floor area
INDUSTRIAL CATEGORIES			
USE CATEGORIES	SPECIFIC USES	MINIMUM PARKING	MAXIMUM PARKING

Industrial Services, Railroad Yards, Wholesale Sales		1 per 1,000 sq. ft. of floor area	1 per 200 sq. ft. of floor area
Manufacturing and Production		1 per 1,000 sq. ft. of floor area	1 per 200 sq. ft. of floor area
Warehouse and Freight Movement		1 per 1,000 sq. ft. of floor area for the first 3,000 sq. ft of floor area and then 1 per 3,500 sq. ft. of floor area thereafter	1 per 200 sq. ft. of floor area
Waste-related		Per CU review	Per CU review

INSTITUTIONAL CATEGORIES

USE CATEGORIES	SPECIFIC USES	MINIMUM PARKING	MAXIMUM PARKING
Basic Utilities		None	None
Colleges		1 per 600 sq. ft. of floor area exclusive of dormitories, plus 1 per 4 dorm rooms	1 per 200 sq. ft. of floor area exclusive of dormitories, plus 1 per 2.6 dorm room
Community Service		1 per 500 sq. ft. of floor area	1 per 200 sq. ft. of floor area
Daycare		1 per 500 sq. ft. of floor area	1 per 200 sq. ft. of floor area
Medical Centers		1 per 500 sq. ft. of floor area	1 per 200 sq. ft. of floor area
Parks and Open Areas		Per CU review for active areas	Per CU review for active areas
Religious Institutions		1 per 100 sq. ft. of main assembly area or per CU review	1 per 60 sq. ft. of main assembly area
Schools	Grade, Elementary, Junior High	1 per classroom	2.5 per classroom

	High School	7 per classroom	10.5 per classroom
OTHER CATEGORIES			
USE CATEGORIES	SPECIFIC USES	MINIMUM PARKING	MAXIMUM PARKING
Agriculture		None or per CU review	None or per CU review
Aviation and Surface Passenger Terminals		Per CU review	Per CU review
Detention Facilities		Per CU review	Per CU review
Essential Public Facilities		Per CU review	Per CU review
Wireless Communication Facilities		None or per CU review	None or per CU review
Rail Lines and Utility Corridors		None	None
<p>[1] The Planning Director may approve different amounts of parking spaces under the exceptions listed in SMC 17C.230.130.</p> <p>(([2] Parking is not required for residential development on sites located within one-half mile of a transit stop.))</p> <p><u>[2] For purposes of calculating parking, an Accessory Dwelling Unit shall count as a full dwelling unit. Studio and one-bedroom ADUs require no additional parking.</u></p> <p>(([3] For middle housing developed in the R1 and R2 zones, the following standards apply:</p> <ul style="list-style-type: none"> • On lots smaller than 6,000 square feet, only one parking space per unit is required regardless of bedroom count. • On lots 6,000 square feet or larger, each unit with 4 or more bedrooms must provide a minimum of two parking spaces.)) <p><u>[3] Single Room Occupancy housing is exempted from parking requirements.</u></p> <p>(([4] Parking requirements for ADUs are provided in SMC 17C.300.130(A)(4).))</p>			

Section 15. That SMC Section 17C.300.130 is amended to read as follows:

Section 17C.300.130 Development Standards

A. Development Standards – Requirements for All Accessory Dwelling Units.

All accessory dwelling units must meet the following:

1. Creation.

An accessory dwelling unit may only be created through the following methods:

- a. Converting existing living area, attic, basement or garage.
- b. Adding floor area.
- c. Constructing a detached accessory dwelling unit on a site with an existing residential use.
- d. Constructing a residential use with an internal or detached accessory dwelling unit.
- e. In the R1, R2, RMF, or RHD zone, constructing an attached or detached accessory dwelling unit on a site with any existing or new principal structure (including non-residential uses or structures). Any structure shall comply with all applicable building, fire, and engineering standards.

2. Number of Residents.

The total number of individuals that reside in all units on the site may not exceed any lawful limits on occupant load per square foot or generally applicable health and safety provisions as established by applicable building or fire code, as provided in RCW 35.21.682.

3. Location of Entrances for Internal ADUs.

Only one entrance may be located on the facade of the structure facing the street, unless the principal structure contained additional entrances before the accessory dwelling unit was created. An exception to this regulation is entrances that do not have access from the ground such as entrances from balconies or decks.

4. Parking.

- a. Studio and one-bedroom ADUs require no additional parking. ~~((One additional off-street parking space is required for the accessory dwelling unit with more than one bedroom, plus one per bedroom after two bedrooms. Existing required parking for the principal structure must be maintained.))~~

~~((b. As an exception to subsection (a), no additional off-street parking space is required for the ADU within one-quarter mile of stops for a bus or other transit mode providing actual fixed route service at intervals of no less frequently than fifteen minutes for at least five~~

~~hours during the peak hours of operation on weekdays, defined as a major transit stop under RCW 36.70A.696.))~~

b. Parking for Accessory Dwelling Units is provided in Table 17C.230.130-1 under Residential Household Living. For purposes of determining required parking, an Accessory Dwelling Unit is a full dwelling unit.

B. Additional Development Standards for Detached ADUs.

1. Setbacks.

Except for conversion of existing accessory structures, the accessory dwelling unit must be:

a. as specified for setbacks in Table 17C.111.205-2 for accessory structures and

2. Height.

The maximum height allowed for a detached accessory dwelling unit is provided in Table 17C.111.205-2.

3. Bulk Limitation.

The building coverage for the detached accessory dwelling unit may not be larger than the building coverage of the principal structure.

a. On lots five thousand five hundred square feet or larger, the combined building coverage of all detached accessory structures may not exceed fifteen percent of the total area of the site.

b. On lots smaller than five thousand five hundred square feet, the combined building coverage of all detached accessory structures may not exceed twenty percent of the total area of the site.

4. Conversion of Existing Detached Accessory Structures.

a. Conversion of an existing detached accessory structure that is in a front building setback required by Table 17C.111.205-2 is not allowed. Conversion of an existing detached accessory structure that is in a rear or side building setback is allowed as provided by SMC 17C.111.235, Setbacks, and SMC 17C.111.240, Accessory Structures.

b. If the accessory dwelling unit is proposed for an existing detached accessory structure that meets any of the standards of subsections (B)(2) and (3) of this section, alterations that will move the structure out of conformance with the standards that are met are not allowed.

c. If the accessory dwelling unit is proposed as a conversion of an existing detached accessory structure or a portion of the building,

and any floor area is added to the existing detached accessory structure to accommodate an ADU, then the entire structure must meet the underlying zoning development standards.

C. Utilities and Addressing.

The ADU must utilize those municipal utilities and address established for the principal dwelling unit.

D. Code Compliance.

The ADU must meet all technical code standards of this title including building, electrical, fire, and plumbing code requirements and permits.

17C.111.205/17C.111.420 RMF & RHD TEXT AMENDMENTS

The proposed Spokane Municipal Code Text Amendments related to building height are citywide and not limited to the South Logan Project Area. The citywide changes implement recommendations from the [South Logan TOD Plan](#), with citywide implementation ensuring consistency of height and multifamily open space requirements throughout Spokane. The proposal includes increased default maximum heights to the RMF (Residential Multifamily) and RHD (Residential High Density) zones as well as adjustments to open space requirements to increase feasibility of higher intensity infill development. Proposed open space requirements include allowing proximity to a public park to count towards open space requirements, which is proposed to apply to all residential zones, including R1 and R2, and having different minimum open space requirements depending on unit size and infill site status in RMF and RHD.

Text with (~~strikethrough~~) is proposed to be repealed/modified with underlined text representing proposed text. Text without a strikethrough or underline is existing and not proposed to be modified.

Section 1. That SMC Section 17C.111.205 be amended to read as follows:

Section 17C.111.205 Development Standards Tables

Development standards that apply within the residential zones are provided in Tables 17C.111.205-1 through 17C.111.205-3.

TABLE 17C.111.205-1					
LOT DEVELOPMENT STANDARDS [1]					
	RA	R1	R2	RMF	RHD
DENSITY STANDARDS					
Maximum density on sites 2 acres or less [2][3]	No maximum	No maximum	No maximum	No maximum	No maximum
Maximum density on sites larger than 2 acres [2]	10 units/acre	10 units/acre	20 units/acre	No maximum	No maximum
Minimum density [2]	4 units/acre	4 units/acre	10 units/acre	15 units/acre	15 units/acre
LOT DIMENSIONS FOR SUBDIVISIONS AND SHORT SUBDIVISIONS					
Minimum lot area	7,200 sq. ft.	1,200 sq. ft.	1,200 sq. ft.	1,200 sq. ft.	1,200 sq. ft.
Minimum lot width with no driveway approach [4]	40 ft.	15 ft.	15 ft.	15 ft.	15 ft.
Minimum lot width with driveway approach [4]	40 ft.	36 ft.	36 ft.	25 ft.	25 ft.

Minimum lot width within Airfield Overlay Zone	40 ft.	40 ft.	36 ft.	25 ft.	25 ft.
Minimum lot depth	80 ft.	80 ft.	40 ft.	N/A	N/A
Minimum lot frontage	40 ft.	Same as minimum lot width	Same as minimum lot width	Same as minimum lot width	Same as minimum lot width
MINIMUM LOT DIMENSIONS FOR UNIT LOT SUBDIVISIONS					
Minimum parent lot area	No minimum	No minimum	No minimum	No minimum	No minimum
Maximum parent lot area	2 acres	2 acres	2 acres	2 acres	2 acres
Minimum child lot area	No minimum	No minimum	No minimum	No minimum	No minimum
Minimum child lot depth	No minimum	No minimum	No minimum	No minimum	No minimum
LOT COVERAGE					
Maximum total building coverage [5][6][7]	50%	65%	80%	100%	100%
Maximum lot impervious coverage without engineer's stormwater drainage plan - not in ADC [5][8]	50%	60%	60%	N/A	N/A
Maximum lot impervious coverage without engineer's stormwater drainage plan - inside ADC [5][8]	40%	40%	40%	N/A	N/A
Notes:					
[1] Plan district, overlay zone, or other development standards contained in Title 17C SMC may supersede these standards.					
[2] See SMC 17C.111.210 for applicability of minimum and maximum density standards in the residential zones.					
[3] Development within Airfield Overlay Zones is further regulated as described in SMC 17C.180.090, Limited Use Standards.					
[4] Lots with vehicle access only from an alley are not considered to have a "driveway approach" for the purposes of this standard.					
[5] Lot and building coverage calculation includes all primary and accessory structures.					
[6] Building coverage for attached housing is calculated based on the overall development site, rather than individual lots.					

[7] Developments meeting certain criteria relating to transit, Centers & Corridors, or housing affordability are given a bonus for building coverage. See SMC 17C.111.225 for detailed eligibility criteria.

[8] Projects may exceed impervious coverage requirements by including an engineer's drainage plan in submittals, subject to review by the City Engineer as described in SMC 17D.060.135. "ADC" means Area of Drainage Concern.

TABLE 17C.111.205-2					
BUILDING AND SITING STANDARDS [1]					
	RA	R1	R2	RMF	RHD
PRIMARY BUILDINGS					
Floor area ratio	N/A	N/A	N/A	N/A	N/A
Maximum building footprint per primary building - lot area 7,000 sq. ft. or less	N/A	2,450 sq. ft.	2,450 sq. ft.	N/A	N/A
Maximum building footprint per primary building - lot area more than 7,000 sq. ft.	N/A	35%	35%	N/A	N/A
Maximum building height [2]	35 ft.	40 ft.	40 ft.	((40)) <u>55</u> ft.	((40)) <u>75</u> ft.
Minimum Setbacks					
Front	15 ft.	10 ft.	10 ft.	10 ft.	10 ft.
Interior side lot line - lot width 40 ft or less [3]	3 ft.	3 ft.	3 ft.	3 ft.	3 ft.
Interior side lot line - lot width more than 40 ft [4] [5]	5 ft.	5 ft.	5 ft.	5 ft.	5 ft.
Street side lot line – all lot widths	5 ft.	5 ft.	5 ft.	5 ft.	5 ft.
Attached garage or carport entrance from street	20 ft.	20 ft.	20 ft.	20 ft.	20 ft.
Rear	25 ft.	15 ft.	15 ft.	10 ft.	10 ft.
ACCESSORY DWELLING UNITS					
Maximum building footprint for accessory dwelling unit - lot area 5,500 sq. ft. or less	1,100 sq. ft.	1,100 sq. ft.	1,100 sq. ft.	1,100 sq. ft.	1,100 sq. ft.
Maximum building footprint for accessory dwelling unit - lots larger than 5,500 sq. ft.	15%	15%	15%	15%	15%
Maximum building height	25 ft.	25 ft.	25 ft.	25 ft.	25 ft.

Minimum side lot line setbacks [5] [6]	Same as Primary Structure				
Minimum rear setback with alley [4] [5] [6]	0 ft.	0 ft.	0 ft.	0 ft.	0 ft.
Minimum rear setback no alley	5 ft.	5 ft.	5 ft.	5 ft.	5 ft.
OTHER ACCESSORY STRUCTURES					
Maximum lot coverage for accessory structures – lots 5,500 sq. ft. or less	20%	20%	20%	See Primary Structure	See Primary Structure
Maximum lot coverage for accessory structures – lots larger than 5,500 sq. ft.	20%	15%	15%	See Primary Structure	See Primary Structure
Maximum building height	30 ft.	20 ft.	20 ft.	35 ft.	35 ft.
Minimum side lot line setbacks [4] [5] [6]	Same as Primary Structure				
Minimum rear setback with alley	0 ft.	0 ft.	0 ft.	0 ft.	0 ft.
Minimum rear setback no alley	5 ft.	5 ft.	5 ft.	5 ft.	5 ft.
OPEN SPACE [7]					
Minimum (outdoor area) <u>open space</u> per unit ([7]) [8]	250 sq. ft.	250 sq. ft.	250 sq. ft.	((200 sq. ft.)) <u>Studio: 48 sq. ft. per unit</u> <u>1- bedroom: 75 sq. ft. per unit</u> <u>2+ bedrooms: 150 sq. ft. per unit</u>	<u>Studio: 48 sq. ft. per unit</u> <u>1-bedroom: 75 sq. ft. per unit</u> <u>2+ bedrooms: 100 sq. ft. per unit</u> <u>Sites 20,000 sq. ft. or less: 36 sq. ft. per unit</u>

Minimum common ((outdoor area)) <u>open space</u> per unit as a substitute for private area - first six units	200 sq. ft.	200 sq. ft.	200 sq. ft.	((150-sq. ft.)) <u>Studio: 48 sq. ft. per unit</u> <u>1- bedroom: 75 sq. ft. per unit</u> <u>2+ bedrooms: 150 sq. ft. per unit</u>	<u>Studio: 48 sq. ft. per unit</u> <u>1-bedroom: 75 sq. ft. per unit</u> <u>2+ bedrooms: 100 sq. ft. per unit</u> <u>Sites 20,000 sq. ft. or less: 36 sq. ft. per unit</u>
Minimum common ((outdoor area)) <u>open space</u> per unit as a substitute for private area - all units after six	150 sq. ft.	150 sq. ft.	150 sq. ft.	((100-sq. ft.)) <u>Studio: 36 sq. ft. per unit</u> <u>1- bedroom: 48 sq. ft. per unit</u> <u>2+ bedrooms: 48 sq. ft. per unit</u>	<u>Studio: ((48)) 36 sq. ft. per unit</u> <u>1-bedroom: 48 sq. ft. per unit</u> <u>2+ bedrooms: 48 sq. ft. per unit</u> <u>Sites 20,000 sq. ft. or less: 25 sq. ft. per unit</u>

Notes:

[1] Plan district, overlay zone, or other development standards contained in Title 17C SMC may supersede these standards.

[2] Base zone height may be modified according to SMC 17C.111.230, Height.

[3] Certain elements such as covered porches may extend into the front setback. See SMC 17C.111.235, Setbacks.

[4] There is an additional angled setback from the interior side lot line. Refer to SMC 17C.111.230(C) and 17C.111.235(E) for more detail.

[5] Setbacks for a detached accessory structure and a covered accessory structure may be reduced to zero feet with a signed waiver from the neighboring property owner as specified in SMC 17C.111.240(C).

[6] Accessory structures may be subject to an additional side setback adjacent to streets as specified in 17C.111.240(C)(5).

[7] Residential units with a continuous pedestrian route as defined in SMC Section 17C.111.420(B) from the property boundary to a public park within 800 feet shall have a minimum of not more than 36 square feet of open space per unit.

~~[[7]]~~ [8] Common ~~((outdoor area))~~ open space may be substituted for private ~~((outdoor area))~~ open space according to SMC 17C.111.310.

TABLE 17C.111.205-3 DEVELOPMENT STANDARDS FOR PROPERTIES QUALIFYING FOR DEVELOPMENT BONUS [1] [2]					
	RA	R1	R2	RMF	RHD
LOT COVERAGE					
Maximum total building coverage	N/A	80%	90%	100%	100%
PRIMARY BUILDINGS					
Floor area ratio	N/A	N/A	N/A	N/A	N/A
Maximum building footprint per primary building - lot area 7,000 sq. ft. or less	N/A	2,450 sq. ft.	2,450 sq. ft.	N/A	N/A
Maximum building footprint per primary building - lot area more than 7,000 sq. ft.	N/A	35%	35%	N/A	N/A
Notes:					
[1] Standards not addressed in this table are consistent with the general standards in Tables 17C.111.205-1 and 17C.111.205-2.					
[2] Criteria to qualify for Development Bonuses is outlined in SMC 17C.111.225.					

Section 2. That SMC Section 17C.111.420 be amended to read as follows:

Section 17C.111.420 ((Outdoor)) Open Spaces

A. Purpose.

To create pedestrian friendly, usable areas through the use of plazas, courtyards, rooftop decks, and other ((outdoors)) open spaces for the enjoyment and health of the residents.

B. ((Outdoor)) Open Spaces Implementation.

1. Minimum Required Space.

((4))a. Each multifamily development shall ((set)) provide ((a minimum of forty-eight square feet of)) the minimum ((outdoor)) open space area for each living unit in the complex, including those units occupied by the owner or building management personnel, as identified in Table 17C.111.205-2. Open spaces may be provided individually, such as by balconies, or combined into a larger common open space. ((Private outdoor spaces can count towards this outdoor common space provision.)) Developments in RMF and RHD may provide both private and common open space to meet the minimum requirement; however, each unit must provide either the full private or common open space to count towards the minimum required space. (R)

b. Residential units with a continuous pedestrian route from the building entrance to a public park within 800 ft are not required to provide more than 36 square feet of open space per unit. For purposes of this requirement, an unsignalized crossing of a minor arterial road or greater shall not be considered a continuous pedestrian route.



Trellis and special landscape defines private courtyard area

[NOTE: Delete graphic above]

2. ~~((Ground Level Units))~~ Private Open Space.

~~((The outdoor area for ground level units is a type of private outdoor space and must be directly accessible from the unit. The area must be surfaced with lawn, pavers, decking or sport court paving which allows the area to be used for recreational purposes. User amenities, such as tables, benches, trees, planter boxes, garden plots, drinking fountains, spas or pools, may be placed in the outdoor area. It may be covered, such as a covered patio, but it may not be fully enclosed. (R)))~~

Private open space area is typically developed for passive recreational use. Examples include balconies, patios, and private rooftop decks.



[NOTE: Delete graphic above]

- a. Private open space must be directly accessible from the unit. (R)
- b. Private open space must be surfaced with landscaping, pavers, decking, or sport court paving which allows the area to be used for recreational purposes. (R)
- c. Private open space may be covered, such as a covered balcony, but may not be fully enclosed. (R)
- d. Berms, low walls, fences, hedges and/or landscaping shall be used to define private open spaces such as yards, decks, terraces, and patios from each other and from the street right-of-way. The material or plantings between private open spaces shall be a maximum of four feet in height and visually permeable, such as open rails, ironwork, or trellis treatment to encourage interaction between neighbors. Material or plantings between units and right-of-way shall meet applicable fencing restrictions. (P)

3. ~~((Upper Level Units))~~ Common Open Space.

~~((Upper level units are a type of private outdoor space. For upper level units, the required outdoor area may be provided individually, such as by~~

~~balconies, or combined into a larger area. If combined into a larger area, it must comply with the following requirements. (R))~~

~~Common open space area may be developed for active or passive recreational use. Examples include play areas, plazas, rooftop patios, picnic areas, fitness centers, pools, tennis courts, and open recreational facilities.~~

- a. ~~The total amount of required ((~~outdoor area for upper level units~~)) common open space is the cumulative amount of the required area per dwelling unit for ((~~individual~~)) common areas, minus any ((~~upper level~~)) units that provide individual ((~~outdoor areas~~)) open space (if provided). However, a combined required ((~~outdoor area~~)) open space must comply with the minimum area ((~~and dimension requirements for combined outdoor areas~~)) and meet ADA Standards for Accessible Design.~~
- b. ~~((The combined outdoor area may be developed for active or passive recreational use. Examples include play areas, plazas, rooftop patios, picnic areas, fitness centers, pools, tennis courts, and open recreational facilities. The area)) Common open space must be surfaced with ((~~lawn~~)) landscaping, pavers, decking, or sport court paving, which allows the area to be used for recreational purposes. ((User amenities, such as tables, benches, trees, planter boxes, garden plots, drinking fountains, spas or pools may be placed in the outdoor area. It may be covered, such as a covered patio, but it may not be fully enclosed.)) (R).~~
- c. ~~Common open space may be covered, such as a covered patio, but may not be fully enclosed unless the open space is an equipped interior fitness area or furnished meeting space not reservable by individual residents. (R)~~
- d. ~~Common open spaces with active uses used to meet these guidelines shall not be located within required buffer areas, if prohibited by critical area or shoreline regulations. (R)~~
- e. ~~Common open spaces shall provide at least three of the following amenities to accommodate a variety of ages and activities. Amenities include: (P)~~
 - i. ~~Site furnishings (benches, tables, bike racks)~~
 - ii. ~~Picnic or outdoor grilling areas~~
 - iii. ~~Patios, plazas, or courtyards~~
 - iv. ~~Tot lots or other children's play areas~~
 - v. ~~Enclosed pet areas that make up no more than fifty percent of the required common open space~~

vi. Community gardens accessible for use by residents

vii. Open lawn

viii. Play fields

ix. Sports courts, such as tennis or basketball courts, and pools that make up no more than fifty percent of the required common open space

x. Interior equipped fitness areas that make up no more than fifty percent of the required common open space

f. If common open spaces are located adjacent to a street right-of-way, landscaping should be used to provide a buffer between outdoor spaces and the street right-of-way. (P)

~~((4. Common outdoor spaces shall provide at least three of the following amenities to accommodate a variety of ages and activities. Amenities include: (P)~~

~~a. Site furnishings (benches, tables, bike racks).~~

~~b. Picnic areas.~~

~~c. Patios, plazas or courtyards.~~

~~d. Tot lots.~~

~~e. Gardens.~~

~~f. Open lawn.~~

~~g. Play fields.~~

~~h. Sports courts, such as tennis or basketball courts (no more than fifty percent of required outdoor common space), equipped interior fitness areas, or pools.))~~



[NOTE: Delete graphic above]



Basketball court provided in common outdoor area

[NOTE: Delete graphic above]

- ~~((5. Common outdoor spaces shall be easily visible and accessible to multifamily residents. (P))~~
- ~~6. Berms, low walls, fences, hedges and/or landscaping shall be used to define private ((outdoor)) open spaces such as yards, decks, terraces, and patios from each other and from the street right-of-way. (P)~~
- ~~7. Walls, hedges, and fences shall be used to define and ensure a sense of privacy in outdoor private spaces. The material or plantings should be a maximum of four feet (high and visually permeable, such as open rails, ironwork, or trellis treatment to encourage interaction between neighbors.) (P))~~
- ~~((8))4. Lighting shall be provided within ((outdoor)) open spaces to provide visual interest, as well as an additional security function. Lighting should not cause off-site glare. (R)~~
- ~~((9. If outdoor spaces are located adjacent to a street right-of-way, landscaping should be used to provide a buffer between outdoor spaces and the street right-of-way. (C))~~



Screening by wall and planting

[NOTE: Delete graphic above]

~~((10.—Common outdoor spaces with active uses used to meet these guidelines shall not be located within required buffer areas, if prohibited by critical area or shoreline regulations. (R))~~

~~((14))~~5. ~~((Outdoor))~~ Open spaces should not be located adjacent to dumpster enclosures, loading/service areas or other ~~((incompatible uses))~~ facility and/or utility enclosures. (C)

EXHIBIT C



NONPROJECT DETERMINATION OF NONSIGNIFICANCE

FILE NO(s): South Logan TOD Implementation

PROPONENT: City of Spokane

DESCRIPTION OF PROPOSAL: This proposal implements the South Logan TOD Plan by amending SMC Sections 17A.020.160 "P" Definitions, 17C.111.205 Development Standards Tables, 17C.111.230 Height, 17C.111.420 Open Spaces, 17C.120.220 Height, 17C.122.070 Center and Corridor Zone Allowed Uses, 17C.122.090 Public Amenities Allowing Bonus FAR, 17C.123.010 Purpose, 17C.123.020 Code Organization, 17C.123.030 Regulating & Street Section Plans, 17C.123.040 Land Use, Height, Placement and Parking, 17C.123.050 Streetscape Requirements, 17C.123.060 Architectural Requirements, 17C.123.070 Additional Requirements, 17C.123.080 Building Type Catalogs, 17C.230.120 Maximum Required Parking Spaces, 17C.230.130 Parking Exceptions, and 17C.300.130 Development Standards. This proposal implements the South Logan TOD Plan by repealing SMC Sections 17C.122.080 Floor Area Ratios (FAR), 17C.122.100 Maximum Building Height, 17C.122.110 Setbacks and Required Sidewalk Width, and Chapter 17C.122T Center and Corridor Zone Development Tables. This proposal implements the South Logan TOD Plan by creating SMC Sections 17C.122.200 Development Standards Table, 17C.122.210 Height, 17C.122.220 Height Transition, 17C.122.230 Floor Area Ratio, 17C.122.240 Setbacks, 17C.122.250 Sidewalks. This proposal implements the South Logan TOD Plan by creating SMC Chapter 17C.420 South Logan Planned Action Ordinance.

The project webpage will be updated with the latest information and proposals
<https://my.spokanecity.org/projects/south-logan-transit-oriented-development-project/>

LOCATION OF PROPOSAL, INCLUDING STREET ADDRESS, IF ANY: Citywide

LEAD AGENCY: City of Spokane

The lead agency for this proposal has determined that it does not have a probable significant adverse impact on the environment. An Environmental Impact Statement (EIS) is not required under RCW [43.21C.030\(2\)\(c\)](#). This decision was made after review of a completed environmental checklist and other information on file with the lead agency. This information is available to the public upon request.

- There is no comment period for this DNS.
- This DNS is issued after using the optional DNS process in section 197-11-355 WAC. There is no further comment period on the DNS.
- This DNS is issued under 197-11-340(2); the lead agency will not act on this proposal for at least 14 days from the date of issuance (below). **Comments regarding this DNS must be submitted no later than 5:00 p.m. on June 26, 2024 if they are intended to alter the DNS.**

Responsible Official: Spencer Gardner **Position/Title:** Director, Planning Services

Address: 808 W. Spokane Falls Blvd., Spokane, WA 99201 **Phone:** 509-625-6097

Date Issued: June 12, 2024 **Signature:** 



APPEAL OF THIS DETERMINATION

After a determination has become final, appeal may be made to:

Responsible Official: City of Spokane Hearing Examiner

Address: 808 W. Spokane Falls Blvd., Spokane, WA 99201

Email: hearingexaminer@spokanecity.org

Phone: 509-625-6010

Deadline: 21 days from the date of the signed DNS
12:00 p.m. on July 3, 2024

The appeal must be on forms provided by the Responsible Official, and make specific factual objections. Appeals must be accompanied by the appeal fee. Contact the Responsible Official for assistance with the specifics of a SEPA appeal.

DETERMINATION OF NONSIGNIFICANCE

Final Audit Report

2024-06-10

Created:	2024-06-10
By:	Tyler Kimbrell (tkimbrell@spokanecity.org)
Status:	Signed
Transaction ID:	CBJCHBCAABAAFyu0ljd9rihLaFwtADboiUDYrv90aj4k

"DETERMINATION OF NONSIGNIFICANCE" History





-  Document created by Tyler Kimbrell (tkimbrell@spokanecity.org)
2024-06-10 - 4:24:17 PM GMT
-  Document emailed to Spencer Gardner (sgardner@spokanecity.org) for signature
2024-06-10 - 4:24:23 PM GMT
-  Email viewed by Spencer Gardner (sgardner@spokanecity.org)
2024-06-10 - 4:39:42 PM GMT
-  Document e-signed by Spencer Gardner (sgardner@spokanecity.org)
Signature Date: 2024-06-10 - 4:39:58 PM GMT - Time Source: server
-  Agreement completed.
2024-06-10 - 4:39:58 PM GMT

EXHIBIT D

PUBLIC COMMENTS

No public comments were received prior to 3 PM on June 19, 2024. Any comments received before the scheduled public hearing on June 26, 2024 will be provided to the Spokane Plan Commission for review.

Public comments received during the South Logan TOD Plan and Final Environmental Impact Statement (FEIS) can be found in the final FEIS report, starting on page 97:

<https://static.spokanecity.org/documents/projects/south-logan-tod/south-logan-tod-feis-2023-11-29.pdf>

EXHIBIT E

AGENCY COMMENTS

No Agency comments were received prior to 3 PM on June 19, 2024. Any comments received before the scheduled public hearing on June 26, 2024 will be provided to the Spokane Plan Commission for review.

Agency comments received during the South Logan TOD Plan and Final Environmental Impact Statement (FEIS) can be found in the final FEIS report, starting on page 97:

<https://static.spokanecity.org/documents/projects/south-logan-tod/south-logan-tod-feis-2023-11-29.pdf>

EXHIBIT F



IMPLEMENTATION OF COMPREHENSIVE PLAN POLICIES

Department of Planning and Economic Development

The following policies of the Comprehensive Plan relate to the proposed updates to the residential development and related sections of the Spokane Municipal Code. The full text of the Comprehensive Plan can be found at www.shapingspokane.org.

Chapter 3 – Land Use

Goal 1 – Citywide Land Use, Policy LU 1.4 Higher Intensity Residential Areas

Direct new higher intensity residential uses to areas in and around Centers and Corridors designated on the Land Use Plan Map and to areas where existing development intensity is already consistent with development of this type.

Discussion: Higher intensity housing of various types is the critical component of a Center. Without substantially increasing population in a center’s immediate vicinity, there is insufficient market demand for goods and services at a level to sustain more intense commercial development. Residential uses in and around Centers generally consist of multi-story condominiums and apartments. In some cases, smaller-scale residential development may be interspersed among those higher intensity uses, but generally uses of higher scale and height should predominate in these areas, especially as proximity to designated Centers or Corridors increases. Likewise, residential development should increase in height, mass, and lot coverage as properties are located closer to commercial areas or where employment is higher.

To ensure that the market for higher intensity residential use is directed to Centers, future housing of higher scale and form is generally limited in other areas. Whenever more intense residential uses are proposed outside the general vicinity of Centers and Corridors, topics such as the proximity of those areas to uses like commercial or downtown uses should be considered. Design and site requirements should be considered that minimize conflict between these areas and other uses.

Goal 3 – Efficient Land Use, Policy LU 3.1 Coordinated and Efficient Land Use

Encourage coordinated and efficient growth and development through infrastructure financing and construction programs, tax and regulatory City of Spokane Comprehensive Plan Amended September 7, 2023 3-19 incentives, and by focusing growth in areas where adequate services and facilities exist or can be economically extended.

Discussion: Future growth should be directed to locations where adequate services and facilities are available. Otherwise, services and facilities should be extended or upgraded only when it is economically feasible to do so.

The Centers and Corridors designated on the Land Use Plan Map are the areas of the city where incentives and other tools should be used to encourage infill development, redevelopment and new development. Examples of incentives the city could use include assuring public participation,

using public facilities and lower development fees to attract investment, assisting with project financing, zoning for mixed-use and higher density development, encouraging rehabilitation, providing in-kind assistance, streamlining the permit process, providing public services, and addressing toxic contamination, among other things.

Goal 3 – Efficient Land Use, Policy LU 3.2 Centers and Corridors

Designate Centers and Corridors (neighborhood scale, community or district scale, and regional scale) on the Land Use Plan Map that encourage a mix of uses and activities around which growth is focused.

Discussion: Suggested Centers are designated where the potential for Center development exists. Final determination is subject to a sub-area planning process.

...

Goal 3 – Efficient Land Use, Policy 3.5 Mix of Uses in Centers

Achieve a proportion of uses in Centers that will stimulate pedestrian activity and create mutually reinforcing land uses.

Discussion: Neighborhood, District, and Employment Centers are designated on the Land Use Plan Map in areas that are substantially developed. New uses in Centers should complement existing on-site and surrounding uses, yet seek to achieve a proportion of uses that will stimulate pedestrian activity and create mutually reinforcing land use patterns. Uses that will accomplish this include public, core commercial/office and residential uses.

All Centers are mixed-use areas. Some existing uses in designated Centers may fit with the Center concept; others may not. Planning for Centers should first identify the uses that do not fit and identify sites for new uses that are missing from the existing land use pattern.

...

Goal 4 – Transportation, Policy LU 4.1 Land Use and Transportation

Coordinate land use and transportation planning to result in an efficient pattern of development that supports alternative transportation modes consistent with the Transportation Chapter and makes significant progress toward reducing sprawl, traffic congestion, and air pollution.

Discussion: The GMA recognizes the relationship between land use and transportation. It requires a transportation element that implements, and is consistent with, the land use element. The transportation element must forecast future traffic and provide information on the location, timing, and capacity needs of future growth. It must also identify funding to meet the identified needs. If probable City of Spokane Comprehensive Plan Amended September 7, 2023 3-27 funding falls short of needs, the GMA requires the land use element to be reassessed to ensure that needs are met.

Goal 4 – Transportation Policy LU 4.6 Transit-Supported Development

Encourage transit-supported development, including a mix of employment, residential, and commercial uses, adjacent to high-performance transit stops.

Discussion: People are more likely to take transit to meet their everyday travel needs when transit service is frequent, at least every 15 minutes. Mixed-use development in these areas will enable less reliance on automobiles for travel, reduce parking needs, and support robust transit ridership. Land use regulations and incentives will encourage this type of development along high-performance transit corridors.

Transit-supported development should be encouraged through the application of development incentives, enhanced design measures, streetscape standards, parking standards, and potential changes in density and use. Each of these measures should be developed through a sub-area planning (or similar) process as each high-performance transit line is planned and developed. These sub-area planning processes should include neighborhood and stakeholder involvement and public participation processes to ensure that site-specific and neighborhood-context issues are addressed and benefits are maximized.

Goal 5 – Development Character, Policy LU 5.1 Built and Natural Environment

Ensure that developments are sensitive to the built and natural environment (for example, air and water quality, noise, traffic congestion, and public utilities and services), by providing adequate impact mitigation to maintain and enhance quality of life.

Goal 5 – Development Character, Policy LU 5.5 Complementary Development

Ensure that infill and redevelopment projects are designed to be compatible with and complement surrounding uses and building types.

Discussion: New infill development and redevelopment should be designed and planned to seek compatibility with its location. Consideration should be given to multiple scales of compatibility, from the site on which the use will be constructed to the wider area in which it will reside. New development or redevelopment should also seek to complement and enhance the existing neighborhood where possible by expanding the choices available in the area and improving the use and form of the area in which it is located. For example, middle housing types provide for increased diversity in scale and form while also maintaining a high level of compatibility with existing residential neighborhoods, especially in those areas where only one housing type was previously available.

Chapter 6 – Housing

Goal H1 – Housing Choice and Diversity, Policy H 1.4 Use of Existing Infrastructure

Direct new residential development into areas where community and human public services and facilities are available.

Discussion: Using existing services and infrastructure often reduces the cost of creating new housing. New construction that takes advantage of existing services and infrastructure conserves

public resources that can then be redirected to other needs such as adding amenities to these projects.

Goal H1 – Housing Choice and Diversity, Policy H 1.7 Socioeconomic Integration

Promote socioeconomic integration throughout the city.

Discussion: Socioeconomic integration includes people of all races, color, religion, sex, national origin, handicap, disability, economic status, familial status, age, sexual orientation, or other arbitrary factors. Often, housing affordability acts as a barrier to integration of all socioeconomic groups throughout the community.

Goal H1 – Housing Choice and Diversity, Policy H 1.11 Access to Transportation

Encourage housing that provides easy access to public transit and other efficient modes of transportation.

Discussion: Transportation is the second largest expenditure after housing and can range from 10 to 25 percent of household expenditures. Examining where housing is City of Spokane Comprehensive Plan 6-8 located and the associated transportation costs may provide a more realistic evaluation of housing affordability in the future.

Chapter 8 – Urban Design and Historic Preservation

Goal DP 1 – Pride and Identity, Policy DP 1.2 New Development in Established Neighborhoods

Encourage new development that is of a type, scale, orientation, and design that maintains or improves the character, aesthetic quality, and livability of the neighborhood.

Discussion: New development should be compatible with the context of the area and result in an improvement to the surrounding neighborhood.

Goal DP 2 – Urban Design, Policy DP 2.2. Design Guidelines and Regulations

Adopt regulations and design guidelines consistent with current definitions of good urban design.

Discussion: The city should use development standards that encourage creativity while ensuring compatibility with the surrounding area and enhancing local character. Maintaining or enhancing the neighborhood's character, livability, and property value is a benefit to the residents of an area and provides business owners with some assurance of community stability. Adopted standards that are adhered to, even when some flexibility is included, offer protection and instill confidence in established and prospective residents and business owners.

Design guidelines should be understandable, enforceable, predictable, and consistent in order to measure and evaluate proposed development. Effective design guidelines include graphic depiction and written text that are clear, understandable, and unambiguous. They function specifically to guide the physical development of projects that require design review. The desire is to create and maintain an attractive and efficient city.

Options such as form-based codes and a design review process should be utilized to ensure that new development is compatible with its neighbors and will meet the city's urban design goals.

Goal DP 2 – Urban Design, Policy DP 2.6 Building and Site Design

Ensure that a particular development is thoughtful in design, improves the quality and characteristics of the immediate neighborhood, responds to the site's unique features - including topography, hydrology, and microclimate - and considers intensity of use.

Discussion: New and remodeled projects can have a major impact on a specific area. Site placement, setbacks, landscaping, intensity of use, and other design considerations should be compatible with the visual character of the surrounding environment. This applies to all new commercial, public, multifamily structures, high density single-family projects, and exterior remodels of existing commercial structures. An accessory structure should be of a lesser square footage and volume and should utilize materials and colors less dominant than the principal structure.

Goal DP 2 – Urban Design, Policy DP 2.7 Historic District and Sub-Area Design Guidelines

Utilize design guidelines and criteria for sub-areas and historic districts that are based on local community participation and the particular character and development issues of each sub-area or historic district.

Discussion: Designated historic districts are unique areas that play a special role in preserving Spokane's character. Each tells a particular story which is illustrated by a set of identified, contributing historic resources. These areas are often catalysts for redevelopment and revitalization. The character of historic districts is fragile and can be lost through large scale change or the cumulative effects of smaller changes. The relationship between historic buildings, streetscapes, and landscape features within historic districts helps define the historic character and should be considered when planning or permitting development or infill. Those areas that have been designated as local historical districts and sub-areas or special areas, such as centers and corridors and downtown Spokane, may need specific guidelines that supplement and augment the citywide general guidelines if it is determined that this is feasible or desired. Local input and the existing characteristics of an historic district or sub-area are the basis for design guidelines used for the evaluation of specific projects in that particular area.

Goal DP 2 – Urban Design, Policy DP 2.12, Infill Development

Encourage infill construction and area redevelopment that complement and reinforce positive commercial and residential character.

Discussion: Infill construction can benefit the community when done in a manner that improves and does not detract from the livability of the neighborhood and the desirable design character of the area.

Goal DP 2 – Urban Design, Policy 2.13 Parking Facilities Design

Minimize the impacts of surface parking on the neighborhood fabric by encouraging the use of structured parking with active commercial storefronts containing retail, service, or office uses, and improve the pedestrian experience in less intensive areas through the use of street trees, screen walls, and landscaping.

Discussion: Walkability is a key element for neighborhood and especially downtown vitality. Active and dynamic building fronts and attractive streetscapes contribute to that environment. Thus, the development of alternatives, such as parking within buildings with active storefronts and/or increased landscaping and screening of surface lots, creates a more pleasant atmosphere for both visitors to and neighbors of commercial centers. Landscape standards for parking lots could include incentives such as reduced parking requirements.

**CITY OF SPOKANE PLAN COMMISSION
FINDINGS OF FACT, CONCLUSIONS, AND RECOMMENDATIONS
REGARDING RESIDENTIAL OPEN SPACE, HEIGHT, AND RELATED AMENDMENTS**

A recommendation of the City of Spokane Plan Commission to the City Council to approve amendments to the Spokane Municipal Code proposed higher intensity residential update text amendments. The proposal amends the Unified Development Code (UDC) Sections 17C.111.205 and 17C.111.420 to implement the adopted South Logan Transit-Oriented Development Plan.

FINDINGS OF FACT:

- A. The City of Spokane adopted a Comprehensive Plan in May of 2001 that complies with the requirements of the Growth Management Act (GMA) as set forth in RCW 36.70A.
- B. In 2021, the Washington State Legislature appropriated \$2.5 million for cities to facilitate transit-oriented development planning in areas with light rail or fixed rail systems, bus rapid transit, high frequency bus service or park and ride lots.
- C. The City of Spokane prepared the Transit-Oriented Development (TOD) Framework Action Plan, adopted by resolution in May 2022 under RES 2022-0039, that identifies strategies best suited to Spokane for supporting TOD along new High-Performance Transit lines, including a focus on South Logan.
- D. The City provided opportunities for meaningful public involvement and review in the South Logan TOD Plan and EIS process, including a community meeting consistent with RCW 43.21C.440; has considered all comments received; and, as appropriate, has modified the proposal or mitigation measures in response to comments, resulting in the Preferred Alternative analyzed in the Final Environmental Impact Statement (FEIS).
- E. The *Final South Logan TOD Plan* and *Final Environmental Impact Statement (FEIS)* were published on November 30, 2023 for final consideration.
- F. On January 29, 2024 Spokane City Council adopted by resolution (RES 2024-0015) the Final South Logan TOD Plan and FEIS as a declaration of the subarea's desired future condition.
- G. In order to facilitate the higher intensity residential development envisioned in the Plan, the adopted Final South Logan TOD Plan called for a review of higher intensity residential design standards, as well as permitted heights. For regulatory consistency throughout Spokane and to ensure the benefits of increased feasibility, the amendments are proposed to affect citywide development regulations.
- H. The draft amendments relied on the 20-month planning process and extensive public engagement that occurred as part of the development of the South Logan TOD Plan. Outreach and public communication specifically about South Logan TOD Implementation began in February 2024 and included the following among others:
 - 1. Logan Neighborhood Council meeting presentation on February 13, 2024;

Findings of Fact, Conclusion, and Recommendation

2. Plan Commission Workshops on March 13, April 10, April 24, May 8, May 22, and June 12, 2024;
 3. Various community tabling events on March 19, April 9, and May 18, 2024;
 4. A virtual information session on April 30, 2024;
 5. Coffee Chat pop-up events on May 4, May 23, and June 1, 2024;
 6. Regular South Logan TOD newsletter and webpage updates, as well as City of Spokane newsletter and social media posts.
- I. Public comment, as well as agency and department comments, received prior to the June 26, 2024, Plan Commission public hearing were included in the staff report.
 - J. On March 13, April 10, April 24, May 8, May 22, and June 12, 2024, the Spokane Plan Commission held workshops to discuss draft language, receive updates on public feedback as well as city department and agency comments, and review and evaluate with city staff alternatives to proposed text changes.
 - K. On April 29, 2024, the Washington State Department of Commerce and appropriate state agencies were given the required 60-day notice of the City's intent to adopt updated development regulations pursuant to RCW 36.70A.106.
 - L. On April 29, 2024, a Notice of Intent to Adopt and Request for SEPA agency comments was issued for the draft code pertaining to the proposed South Logan TOD Implementation text amendments. The comment period ended on May 13, 2024. No comments were received.
 - M. The SEPA Determination of Nonsignificance and Checklist were issued by Planning Services on June 12, 2024. The comment period ended on June 26, 2024. No comments were received.
 - N. Prior to the Plan Commission public hearing, a legal notice was published in the *Spokesman-Review* on June 12 and June 19, 2024; and
 - O. The proposed text amendments were drafted and reviewed pursuant to the process established under RCW 36.70A.370 to ensure that the proposed changes will not result in unconstitutional takings of private property.
 - P. Amendments to Title 17 are subject to review and recommendation by the Plan Commission.

Findings of Fact, Conclusion, and Recommendation

- Q. On June 26, 2024, the Spokane Plan Commission held a public hearing on the proposed text amendments, including the taking of verbal testimony, and closed the public record on that date.
- R. Public comment, as well as agency and department comments, received prior to the June 26, 2024 Plan Commission public hearing were included in the staff report.
- S. During deliberations held on June 26, 2024, the Plan Commission discussed the concerns expressed in public comments and testimony about public safety within the South Logan Subarea.
- T. Except as otherwise indicated in the above findings, the Spokane Plan Commission adopts the findings and analysis set forth in the staff report prepared for the proposal.
- U. The Spokane Plan Commission finds that the proposed text amendments meet the decision criteria established in SMC 17G.025.010(G).

CONCLUSIONS:

Based upon the draft text amendments, staff report and analysis (which is hereby incorporated into these findings, conclusions, and recommendations), SEPA review, agency and public comments received, and public testimony presented, the Spokane Plan Commission makes the following conclusions with respect to the text amendments to the Hamilton Form-Based Code:

1. The Plan Commission finds that the proposed amendments bear a substantial relation to the public health, safety, welfare, and protection of the environment pursuant to the requirements outlined in SMC 17G.025.010(G).
2. The proposed text amendments will implement the goals and policies of the Comprehensive Plan.
3. The proposed text amendments will implement the adopted South Logan Transit-Oriented Development Plan.
4. Interested agencies and the public have had extensive opportunities to participate throughout the process and persons desiring to comment were given an opportunity to comment.
5. SEPA review was completed for the proposal, and pursuant to SEPA, any adverse environmental impacts associated with the proposed regulations will be mitigated by enforcement of the City's development regulations.
6. Plan Commission concludes that the intent of the including neighborhood councils to the list of entities that receive notice of applications was to give neighborhood councils standing and the ability to advocate for their neighborhood residents. As entities of standing, neighborhood councils should assume the responsibility of proactively communicated with their residents about pertinent all-city or neighborhood-specific development applications.

7. The Plan Commission finds that the proposed amendments are consistent with the applicable provisions of the Comprehensive Plan, particularly the following adopted goals and policies:
 - a. Chapter 3: Land Use – Goal 1 – Citywide Land Use, Policy LU 1.4 Higher Intensity Residential Areas
 - b. Chapter 3: Land Use – Goal 3 – Efficient Land Use, Policy LU 3.1 Coordinated and Efficient Land Use
 - c. Chapter 3: Land Use – Goal 3 – Efficient Land Use, Policy LU 3.2 Centers and Corridors
 - d. Chapter 3: Land Use – Goal 3 – Efficient Land Use, Policy 3.5 Mix of Uses in Centers
 - e. Chapter 3: Land Use – Goal 4 – Transportation, Policy LU 4.1 Land Use and Transportation
 - f. Chapter 3: Land Use – Goal 4 – Transportation, Policy LU 4.6 Transit-Supported Development
 - g. Chapter 3: Land Use – Goal 5 – Development Character, Policy LU 5.1 Built and Natural Environment
 - h. Chapter 3: Land Use – Goal 5 – Development Character, Policy LU 5.5 Complementary Development
 - i. Chapter 6: Housing – Goal H1 – Housing Choice and Diversity, Policy H 1.4 Use of Existing Infrastructure
 - j. Chapter 6: Housing – Goal H1 – Housing Choice and Diversity, Policy H 1.7 Socioeconomic Integration
 - k. Chapter 6: Housing – Goal H1 – Housing Choice and Diversity, Policy H 1.11 Access to Transportation
 - l. Chapter 8: Urban Design and Historic Presentation – Goal DP 1 – Price and Identity, Policy DP 1.2 New Development in Established Neighborhoods
 - m. Chapter 8: Urban Design and Historic Preservation – Goal DP 2 – Urban Design, Policy DP 2.2 Design Guidelines and Regulations
 - n. Chapter 8: Urban Design and Historic Preservation – Goal DP 2 – Urban Design, Policy DP 2.6 Building and Site Design
 - o. Chapter 8: Urban Design and Historic Preservation – Goal DP 2 – Urban Design, Policy DP 2.7 Historic District and Sub-Area Design Guidelines
 - p. Chapter 8: Urban Design and Historic Preservation – Goal DP 2 – Urban Design, Policy DP 2.12 Infill Development
 - q. Chapter 8: Urban Design and Historic Preservation – Goal DP 2 – Urban Design, Policy 2.13 Parking Facilities Design

- r. Chapter 11: Neighborhoods – Goal N 4 – Traffic Circulation, Policy N 4.7 Pedestrian Design
8. The Plan Commission recognizes the concerns expressed by community members about public safety within the South Logan Subarea. While the Plan Commission urges continued community collaboration with public safety and code enforcement officials, the body recognizes the positive impact that transit-oriented and pedestrian-oriented development can have on public safety within the built environment. Increased density and mix of uses made possible with amendments to the Center and Corridor zones, higher intensity residential zones, and height allowances, as well as street activation as called for in the Hamilton Form-Based Code, encourage more eyes on the street and have been found to have a positive effect on safety and walkability.

RECOMMENDATION:

In the matter of the ordinance pertaining to the Hamilton Form-Based Code, amending the Unified Development Code of the City of Spokane:

1. By a vote of seven to zero, the City of Spokane Plan Commission recommends to the Spokane City Council the **APPROVAL** of the proposed amendments to Sections 17C.111.205 and 17C.111.420.
2. The City of Spokane Plan Commission authorizes the Plan Commission President to prepare and sign on the Commission’s behalf a written decision setting forth the Plan Commission’s findings, conclusions, and recommendations on the proposed amendments.

Greg Francis

[Greg Francis \(Jun 27, 2024 17:44 PDT\)](#)

Greg Francis, President

Spokane Plan Commission

Jun 27, 2024 a date.

PC Findings and Conclusions_ RMF RHD Code

Final Audit Report

2024-06-28

Created:	2024-06-27
By:	AMANDA KIEHN (AKIEHN@SPOKANECITY.ORG)
Status:	Signed
Transaction ID:	CBJCHBCAABAAALcmmmgj0vTBy6fLoKrtUA953N2CH1X4d

"PC Findings and Conclusions_ RMF RHD Code" History

 Document created by AMANDA KIEHN (AKIEHN@SPOKANECITY.ORG)

2024-06-27 - 10:06:41 PM GMT

 Document emailed to gfrancis@spokanecity.org for signature

2024-06-27 - 10:07:09 PM GMT

 Email viewed by gfrancis@spokanecity.org

2024-06-28 - 0:44:44 AM GMT

 Signer gfrancis@spokanecity.org entered name at signing as Greg Francis

2024-06-28 - 0:44:55 AM GMT

 Document e-signed by Greg Francis (gfrancis@spokanecity.org)

Signature Date: 2024-06-28 - 0:44:57 AM GMT - Time Source: server

 Agreement completed.

2024-06-28 - 0:44:57 AM GMT

**(Note: These 19 pages of comments apply to Final Reading Ordinances C36552 through C36556)
(Comment pages 10-19 received on 8-9-2024)**



June 26, 2024

City of Spokane
Attn: City of Spokane Plan Commission
808 West Spokane Falls Boulevard
Spokane, WA 99201-3333

Dear City of Spokane Plan Commission,

I am writing to confirm Spokane Transit Authority's (STA) continued support for the South Logan Transit Oriented Development (TOD) project. Land use and transit are inherently linked. By updating these development regulations to further support TOD, STA and our regional partners have laid a solid foundation for transit in the Logan neighborhood for years to come. The City Line, our region's first Bus Rapid Transit (BRT) line, is approaching its one-year anniversary of its service launch in July 2023, and to date has carried over 600,000 passengers. City Line is now running at seven-and-a-half-minute frequency at peak hours of operation—a frequency unmatched by any other route in the system, allowing for greater flexibility for riders. The service has been celebrated as a major step forward in delivering high quality transit to the Spokane region.

The City Line serves the South Logan subarea with four major stop pairs, and much of the subarea is within a quarter mile radius of a stop. The South Logan TOD project would help the City leverage the success of the City Line and allow for much needed growth in the area. With the City Line as its backbone and these new development regulations, the South Logan subarea has a solid foundation to support TOD, helping to create a more pedestrian friendly neighborhood with a mix of uses, which can be a model for future developments across the City on BRT and other High Performance Transit (HPT) corridors.

Sincerely,

A handwritten signature in blue ink, appearing to read 'K. Otterstrom'.

Karl Otterstrom, AICP
Chief Planning and Development Officer



Futurewise
1201 3rd Ave #2200, Seattle, WA 98101
(206) 343-0681
futurewise.org



June 26, 2024

Greg Francis, President
Spokane Plan Commission
Department of Planning Services
808 W. Spokane Falls Blvd.
Spokane, WA 99201

Dear Chair Francis and Commission Members:

Subject: Comments on the South Logan TOD Implementation draft text amendments for the June 26, 2024, Public Hearing.
Send via email to: SouthLoganTOD@spokanecity.org.

Thank you for the opportunity to comment on the South Logan TOD Implementation draft text amendments for the June 26, 2024 Plan Commission public hearing. We do have some suggestions to make the text amendments more effective set out below.

Futurewise works throughout Washington State to support land-use policies that encourage healthy, equitable and opportunity-rich communities, and that protect our most valuable farmlands, forests, and water resources. Futurewise has members and supporters throughout Washington State including the City of Spokane and Spokane County.

Futurewise supports this zone because it will provide opportunities for a variety of uses and more affordable housing, to reduce greenhouse gas pollution, and to provide more housing choices. We do have some suggestions below.

Comments on the Area Specific Code Proposals

Futurewise expresses their support for the City's efforts to simplify the Hamilton Form-Based Code. The consolidation of four Context Areas into one will significantly improve clarity and ease of use, making development regulations more transparent and easier to implement.

Futurewise also applauds the removal of parking minimums and the prohibition of drive-thrus, both of which align with contemporary urban planning principles and promote walkability and sustainability.



While the proposed changes are largely positive, I have concerns about the 0-15 foot minimum setbacks. Allowing structures as close as 12 feet from the back of the curb in certain circumstances may compromise pedestrian safety and comfort, especially if sidewalks are narrow.

Additionally, the lack of guidelines related to sustainable design and trail-oriented development is a missed opportunity. We suggest considering these elements as either bonuses or mandatory requirements to encourage environmentally responsible and community-integrated development.

Further, Futurewise supports the streamlining of desired development by reviewing potential impacts at a larger scale during the planning stage and establishing thresholds to determine if site-specific development requires additional environmental impact evaluation.

The clarification that areas within the Planned Action area subject to the Shoreline Master Program must comply with Chapter 17E.060 SMC Shoreline Regulations is essential for protecting our valuable shoreline resources.

The ordinance's mandate for the City to monitor development progress and review the ordinance within five years is a commendable approach to ensuring the plan's effectiveness and adaptability.

Comments on City Wide Code Proposals

Futurewise supports the removal of minimum parking requirements. Research has shown that households in transit-oriented developments own fewer cars and are less reliant on automobiles. ¹Eliminating parking minimums allows developers to respond to actual market demand rather than arbitrary requirements.²

Futurewise supports the prohibition of drive-thrus in CC1 zones. Futurewise suggests extending this prohibition to all CC zones, as drive-thrus are inherently incompatible with walkable, pedestrian-friendly environments.

While the reduction of open space requirements in RMF and RHD zones may be well-intentioned, FW is concerned that it conflicts with the findings of the FEIS,

¹ National Academies of Sciences, Engineering, and Medicine, Effects of TOD on Housing, Parking, and Travel p. 6 (Washington, DC: The National Academies Press: 2008) last accessed on June 25, 2024, at <https://doi.org/10.17226/14179>.

² Futurewise | GGLO | Transportation Choices Coalition, Transit-oriented communities: A Blueprint for Washington State pp. 27 – 29 (Oct. 2009) last accessed on Feb. 27, 2024, at: <http://www.reconnectingamerica.org/assets/Uploads/tccblueprintfortoc2009.pdf>



Comments on the South Logan TOD Implementation draft text amendments for the June 26, 2024, Public Hearing.

Page 3

which notes a deficit in park and recreational space and features. We urge the City to further consider programs for insuring adequate access, development, and maintenance plans for open space to enhance the quality of life for residents.

Thank you for considering our comments. If you require additional information, please contact me at telephone 206-343-0681 or email: brooke@futurewise.org

Very Truly Yours,

Brooke Frickleton
Deputy Legal Director



From: johnbryant777@gmail.com
To: [Downey, KayCee](#)
Cc: [MacDonald, Steven](#); [Scott, Alexander](#); ["Cindy Bryant"](#)
Subject: RE: South Logan TOD Update – Public Hearing Scheduled for Wednesday, June 26
Date: Friday, June 21, 2024 9:04:48 AM

[CAUTION - EXTERNAL EMAIL - Verify Sender]

KayCee,

Thank you.

Cindy and I look forward to attending next Wednesday's South Logan TOD Implementation presentation at City Hall next Wednesday at 4 p.m.

An immediate issue that I do not read or see within the S. Logan Plan information packet is investment into public safety with crime, prostitution in automobiles and active drug usage in public view.

It appears that when the transient populations at the 7-11 on Division (by Dick's Dive-In) are pushed away, these groups move into the S. Logan Neighborhood and business areas. This is confirmed by Metro Security that works the 7-11 on Division and the S. Logan Neighborhood.

S. Logan residents, churches and businesses are deeply concerned for their own safety and the safety of students, youth and the general public in the S. Logan area.

Riverwalk Property has two different churches with youth within the property. Within a few hundred feet of Riverwalk Property is a youth gymnastic facility, JOYA and the Centennial path. This area has become a hub for prostitution, drugs and crime. The Centennial Trail is not safe for Gonzaga Univ. faculty, staff, students and parents to enjoy. A woman was beaten nearly unconscious in this same area by the Centennial Trail, JOYA and the Iron Bridge within the past two months. This S. Logan area is not safe during the day and after dark.

JOYA staff are informed not to walk the Centennial Path alone in this area. It is proven not safe in the S. Logan Neighborhood.

Last week, we had a staff member hospitalized after asking a transient woman smoking some type of drug to leave the Riverwalk Property bathroom. Our employee immediately became clammy, experienced numbness, a massive migraine and started throwing up. The drugs, crime and prostitution are now moving into the Riverwalk Property, the two churches within Riverwalk Property and surround the youth gymnastic facility and JOYA.

Request:

I request adding the above public safety concerns to the S. Logan Neighborhood Planning. I would be open to speaking on this topic.

Thank you,

John Bryant
Owner

From: johnbryant777@gmail.com
To: [Downey, KayCee](#)
Cc: "[Cindy Bryant](#)"
Subject: S. Logan Neighborhood Meeting at City Hall tomorrow @ 4 p.m.: Request for room location
Date: Tuesday, June 25, 2024 10:39:43 AM

[CAUTION - EXTERNAL EMAIL - Verify Sender]

Downey,

Good morning.

Would you be able to direct me to the City Hall location for tomorrow's 4 p.m. S. Logan Neighborhood Plan meeting?

Cindy & I will both attend.

Additional S. Logan Neighborhood Information:

We recently had a criminal on-site that was pushed off the Gonzaga University Campus. The person was kicked out of the Union Gospel Mission, went to Gonzaga University Campus and then to Riverwalk Property to commit their crime. The criminal then utilized the Spokane city bus system to move onto another area of the city.

Public Safety:

The amount of transient traffic into our S. Logan Neighborhood area is unprecedented with drugs, crime, prostitution, most likely sex trafficking and vandalism. We need public safety as a priority with planning.

The night before the new Trent Ave. Bridge ribbon cutting with government and other dignitaries, the bridge was vandalized and spray painted. Criminals stripped out the copper from the new bridge lights and threw custom made metal face plates into the river. They also spray painted the bridge.

The morning of the new Trent Bridge ribbon cutting, officials scrambled to hide the spray paint and vandalism (financial & safety damage) and put on a good face on the new bridge.

Trent Bridge is now a home to transients under the bridge, continuous spray painting, vandalism and a crime corridor with ease of access (foot path) from Union Gospel Mission to the neighborhoods of Riverwalk Property, Churches, Youth Gymnastic facility, JOYA and Gonzaga University Campus. Criminals then utilize public busses to swiftly move to another area of town.

The janitor at Riverwalk Property was recently robbed of the building keys (all doors) and his cell phone. We were able to track the criminal around greater Spokane utilizing the public transportation system. The criminal was on the Gonzaga Univ. Campus and was asked to leave by campus security.

This speaks to what we are experiencing in our S. Logan Neighborhood. We are hurting. Many are scared. We have a consistent & growing level of crime & drugs. Drug dealers, other criminals and prostitution is now more embolden without fear of repercussion or

accountability. We have transients (drug dealers, criminals that actively stake out our businesses and prostitution) openly entering our private businesses and organizations. Children our not safe outdoors in the S. Logan Neighborhood in many areas. Criminals & drug dealers are causing more than intimidation, more than structural damage and financial losses, they are now causing harm to the people that we employ and the people that we serve. They are now entering our buildings.

Thank you,

John Bryant
Owner
No-Li Brewhouse
C/ (970) 980-4540

From: [Justin Haller](#)
To: [Planning & Development Services South Logan TOD Project](#)
Subject: Re: South Logan TOD Update – Public Hearing Scheduled for Wednesday, June 26
Date: Tuesday, June 18, 2024 11:52:55 AM

[CAUTION - EXTERNAL EMAIL - Verify Sender]

So you're going to tear out the bus stop at Indiana and division because the homeless people are camping out there and now the homeless people are still camping out there how is that okay? Why do you penalize sta riders?

On Tuesday, June 18, 2024 at 09:00:53 AM PDT, City of Spokane Planning <southlogantod@spokanecity.org> wrote:

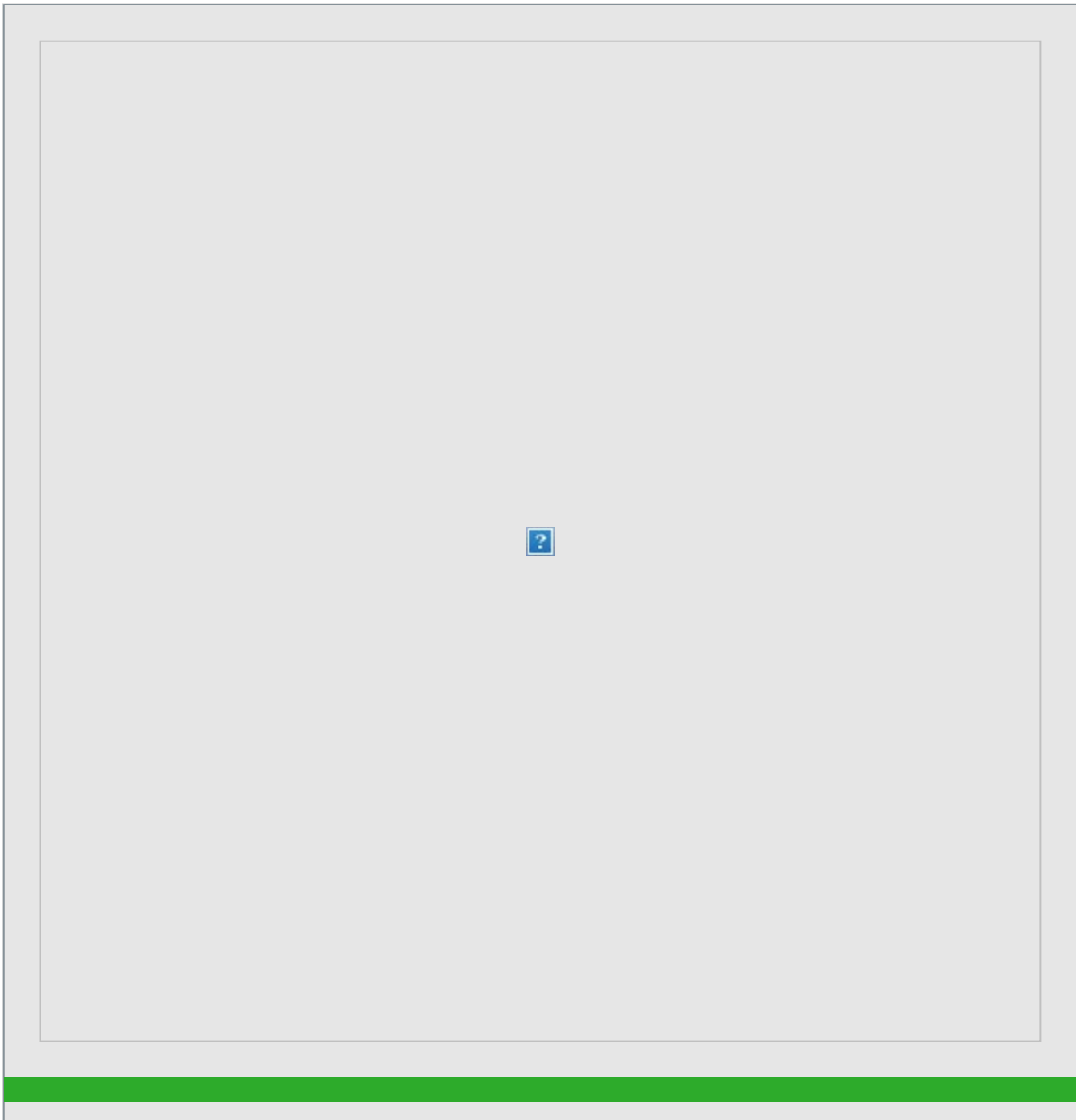



From: [James Bond](#)
To: [Planning & Development Services South Logan TOD Project](#)
Subject: Re: South Logan TOD Update – City Council to Consider Code Amendments Aug. 12
Date: Friday, July 19, 2024 1:57:35 PM

[CAUTION - EXTERNAL EMAIL - Verify Sender]

Why can we just drive a car? Why are you trying to force people to do what you want?

On Friday, July 19, 2024 at 09:03:41 AM PDT, City of Spokane Planning
<southlogantod@spokanecity.org> wrote:

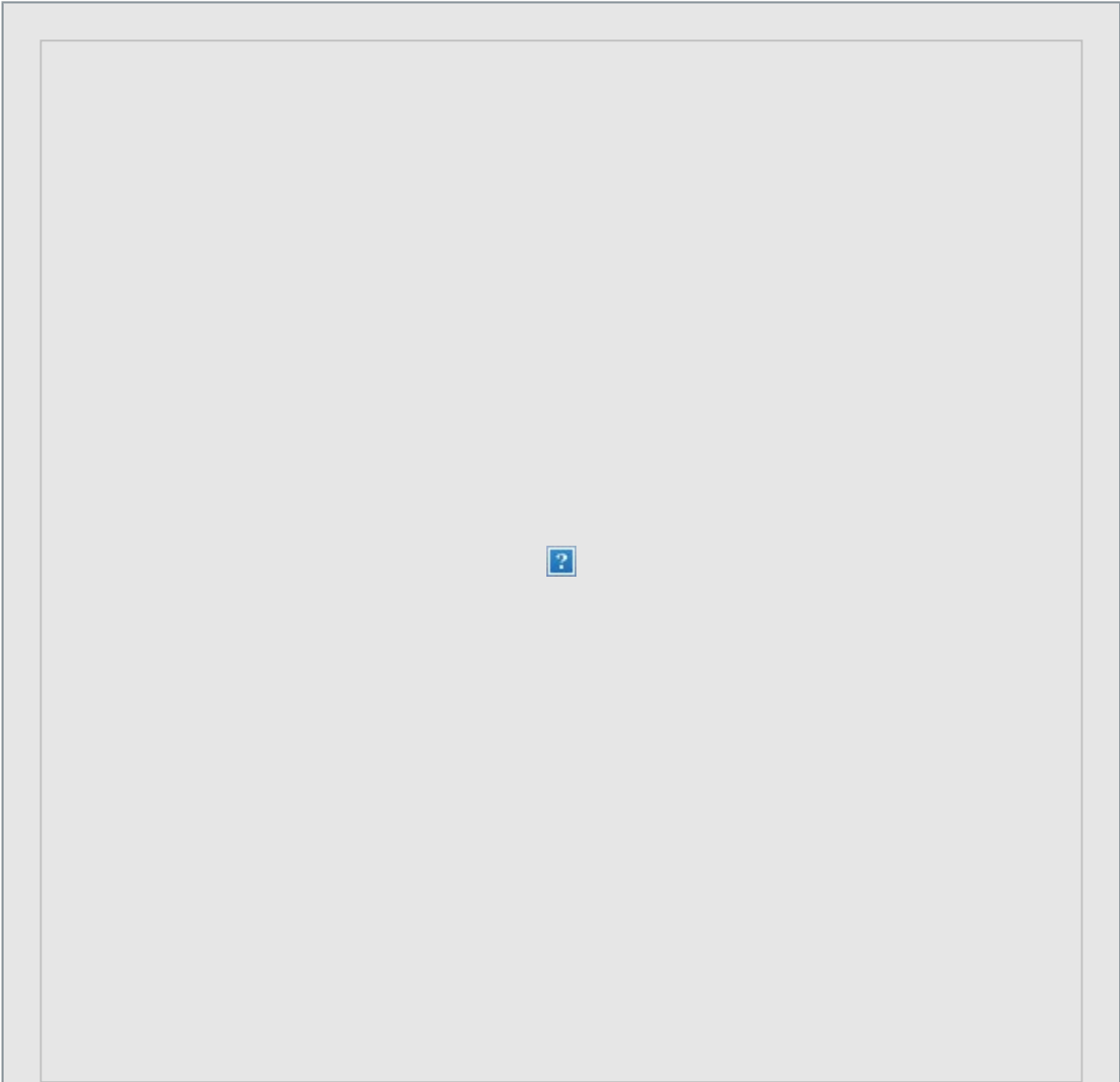

Dear Community Member,

Thank you for your continued participation and involvement in the South Logan Transit-Oriented Development project. After a 20-month planning effort to create the [South Logan TOD Plan](#) and further community feedback on implementation efforts, City Council will consider the South Logan TOD Implementation code amendments for adoption on **Monday, Aug. 12, 2024 at 6 p.m.**

The proposals make area-specific and citywide changes to support transit- and pedestrian-oriented development. [Read more about the envisioned transit-oriented future for South Logan and beyond.](#)

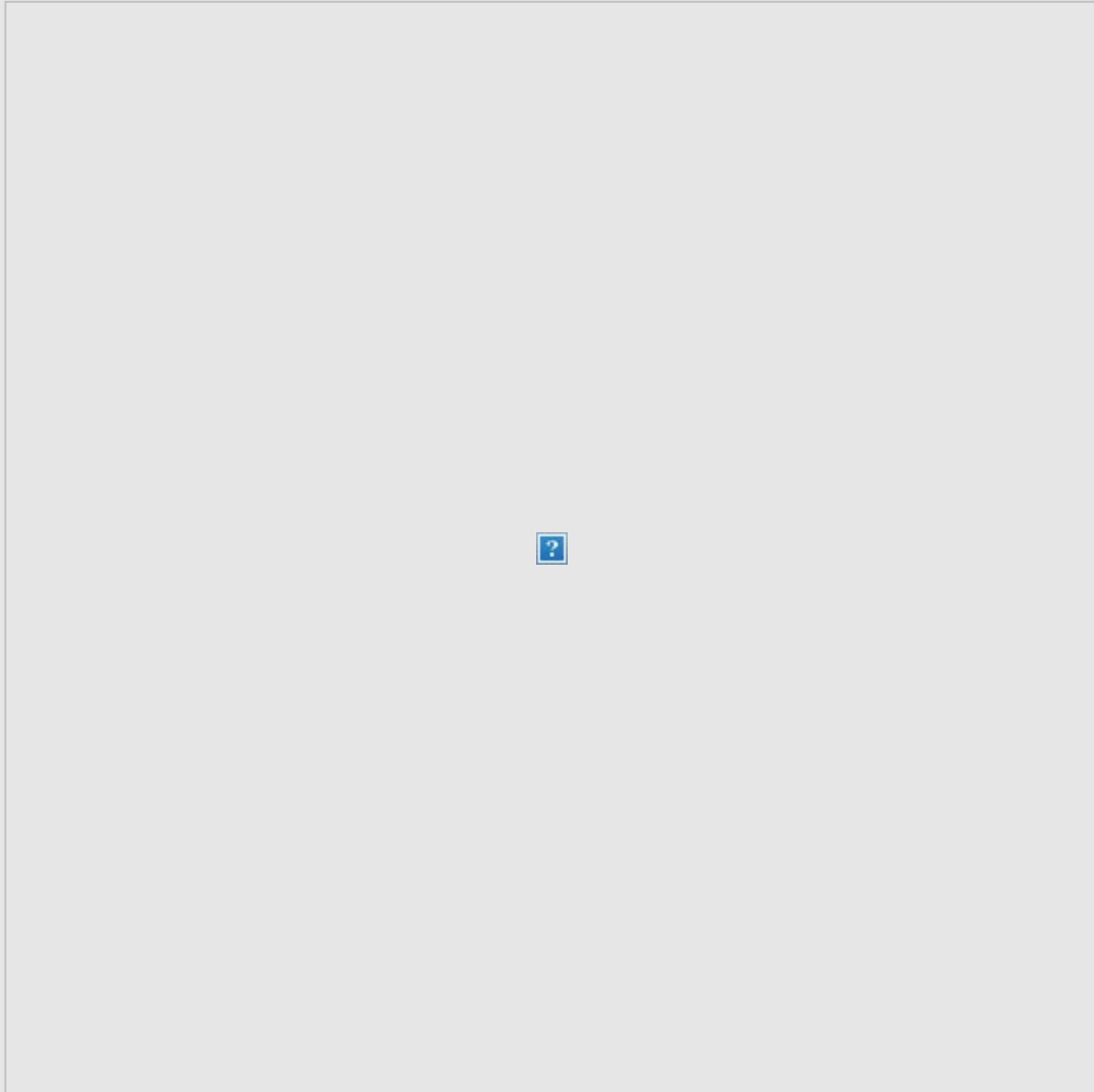

Next Steps

Written testimony can be sent via email in advance of the City Council meeting to southlogantod@spokanecity.org. Verbal testimony will be heard at the City Council meeting on Monday, Aug. 12.

You are receiving this email because you signed up via the [South Logan TOD webpage](#) or have been identified as an individual or stakeholder in the discussion, or expressed interest in receiving planning project updates from the City of Spokane. Please feel free to share this email with others who are interested in receiving [email updates](#) like this one about this project. To unsubscribe, please email southloganTOD@spokanecity.org.

City of Spokane, Washington | 808 W Spokane Falls Blvd | Spokane, WA 99201 US

[Unsubscribe](#) | [Update Profile](#) | [Constant Contact Data Notice](#)

Constant Contact



From: johnbryant777@gmail.com
To: [Downey, KayCee](#); "[Cindy Bryant](#)"
Cc: "[Colleen Fuchs](#)"; "[mark baier](#)"; "[gavinjs](#)"; "[David Birge](#)"
Subject: RE: South Logan TOD Update – City Council to Consider Code Amendments Aug. 12
Date: Friday, July 19, 2024 10:10:13 AM

[CAUTION - EXTERNAL EMAIL - Verify Sender]

Kaycee,

Thank you for the update.

Cindy and I will attend the Monday, August 12th South Logan TOD code amendments meeting at Spokane City Hall.

Update:

I have placed a request into the Mayor's office to fence off (close) the pedestrian pathway underneath the relatively new Trent Ave Bridge (east side).

The asphalt pathway under the Trent Ave. Bridge is a public safety hazard.

The pathway is blocked by transients with numerous tents, tarps, shopping carts, fire making materials and urinate and defecate onto the pathway and into the Spokane River. Garbage is also on the pathway and thrown into the Spokane River.

We continue to report the South Logan Neighborhood Public Safety Hazard to 311, Crime Check, City Council, Mayor's Office and State Representatives.

-
Request:

Please forward the following 311 correspondence into the written record and share with the South Logan TOD leaders.

Appreciate your time and support. John Bryant, Owner, No-Li Brewhouse

From: johnbryant777@gmail.com <johnbryant777@gmail.com>

Sent: Tuesday, July 16, 2024 6:53 PM

To: 'Ruffing, Jason' <jruffing@spokanecity.org>

Subject: RE: Camp and other issues under Trent bridge

Jason,

Thank you for the note. We appreciate the response.

Clarification:

We have a real public safety issue that threatens our staff, our customers, the most vulnerable in our community and our business. We are not dealing with only nuisances. We are dealing with people committing crimes that affect the safety and lives of our citizens.

We experience drug activity, second-hand exposure to drugs smoked in our building by transient peoples, indecent exposure including public urination and defecating in front of

children and families, threats of physical violence, prostitution and sex trafficking under the Trent Ave. Bridge. Additionally, vandalism atop Trent Ave. Bridge; copper fixtures were stripped away that had provided path lighting. These issues extend repeatedly to the Iron Bridge, Centennial Trail and along Superior and Columbus Avenues. We are in a high-density crime and public safety threat area.

We are in close proximity (hundreds of feet) of two churches, a youth gymnastics facility and JOYA. We also have the Union Gospel Mission.

We are communicating daily with Dan and Phil at UGM. The UGM Team is checking underneath the Trent Ave. bridge daily to assure that the individuals and groups of transient people are not being serviced by UGM. UGM is familiar with various violent individuals that are living on the banks of the Spokane River by Superior Ave., Columbus Ave and Trent Ave bridge. These individuals simply move around within a ¼ mile area.

Today, we witnessed a man stand at the Spokane Riverfront bank and urinate while facing visitors. He then proceeded to flip the middle finger. Additionally, another male dropped his pants and defecated. They were also blocking the pedestrian pathway.

Request:

Would you close the path underneath the Trent Ave. Bridge? It is unsafe for residents to utilize. Whose decision making will decide if the pathway can be closed for public safety.

We appreciate that you visited the Trent Ave. Bridge today. We currently have two transient men, mentioned above, under the bridge. This is how the large encampment started two weeks ago. We called 311 and then Crime Check numerous times per day for over 7 days. In this time, countless local residents and tourists (families & children) were subjected to witnessing nudity, bathing in the river, using the river as a bathroom, foul language, fires under the bridge, garbage thrown around the area and garbage thrown into the Spokane River. There was a confirmed violent felon staying under the bridge and staying along the bank of the Spokane River within a ¼ mile of all properties stated above.

The encampment on the banks of the Spokane River by the Iron Bridge, JOYA and the youth gymnastics facility was moved and broken up temporarily. This encampment appears to have then moved underneath the Trent Ave. Bridge. Sunday, the encampment under the bridge was broken up. Today, two men returned. We do not know where the other transients were pushed temporarily. The result is the same, we have two churches, JOYA, youth gymnastics facility and Gonzaga University students experiencing the danger in various areas within the same ¼ mile.

The damage to our building and No-Li business is extensive with stolen business vehicles, three heavily damaged business vehicles, 31 propane tanks stolen, damages & vandalized property, merchandise stolen from within the business, a staff member hospitalized with second hand smoked drugs in our bathroom and more. It is more frequent and more dangerous each week.

We realize that you are in a reactionary and defense mode to respond to the greatest immediate levels of code enforcement. We do have an increasing public safety crisis in Spokane.

We appreciate you enforcing city codes and cleaning up the recent garbage.

Sincerely,

John Bryant
Owner
No-Li Brewhouse

From: Downey, KayCee <kdowney@spokanecity.org>
Sent: Friday, July 19, 2024 9:30 AM
To: John Bryant <johnbryant777@gmail.com>; Cindy Bryant <cindyb@nolibrewhouse.com>
Subject: FW: South Logan TOD Update – City Council to Consider Code Amendments Aug. 12

Good morning,

I wanted to send you a direct update on the South Logan TOD code amendments. Originally we were planning on July 29 for the hearing. However, with summer breaks we had to move the schedule around a bit. The final date for the City Council public hearing is **August 12**.

Please let me know if you have any questions.

Thanks!
KayCee



KayCee Downey, AICP (*she/her*) | City of Spokane | Planner II | Planning & Economic Development
509.625.6194 | dept. 509.625.6500 | kdowney@spokanecity.org | spokanecity.org

Questions about a Middle Housing project? Schedule an appointment with the [Middle Housing Support Team](#) for assistance navigating the development process.

This email is subject to Washington State Public Records Act, Chapter 42.56 RCW, and may therefore be subject to public disclosure.

From: City of Spokane Planning <southlogantod@spokanecity.org>
Sent: Friday, July 19, 2024 9:04 AM
To: Downey, KayCee <kdowney@spokanecity.org>
Subject: South Logan TOD Update – City Council to Consider Code Amendments Aug. 12

[CAUTION - EXTERNAL EMAIL - Verify Sender]

•

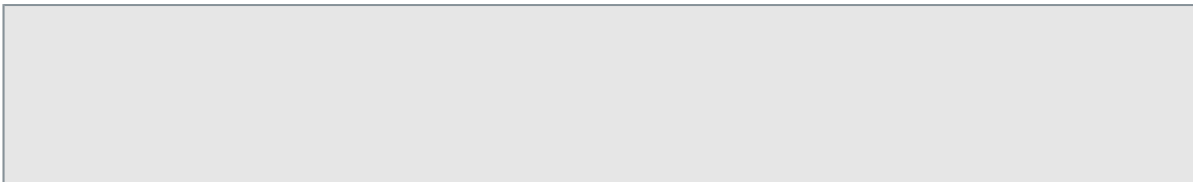

From: [John Bryant](#)
To: [Downey, KayCee](#)
Subject: Transient with switchblade in No-Li Brewhouse tonight
Date: Saturday, July 20, 2024 10:25:50 PM
Attachments: [IMG_7603.PNG](#)

[CAUTION - EXTERNAL EMAIL - Verify Sender]

>> 311, Crime Chexk,

>>

>> This person entered No-Li tonight with a switchblade.

>>

>> A young adult female staff member was confronted with him. Please, public safety is at a crisis level by Trent Ave Bridge, Superior & Columbus Ave. by Riverwalk Property, Summit Church and JOYA.

>>

>> We have clearly posted signs of no weapons (firearms or knives) allowed in the business.

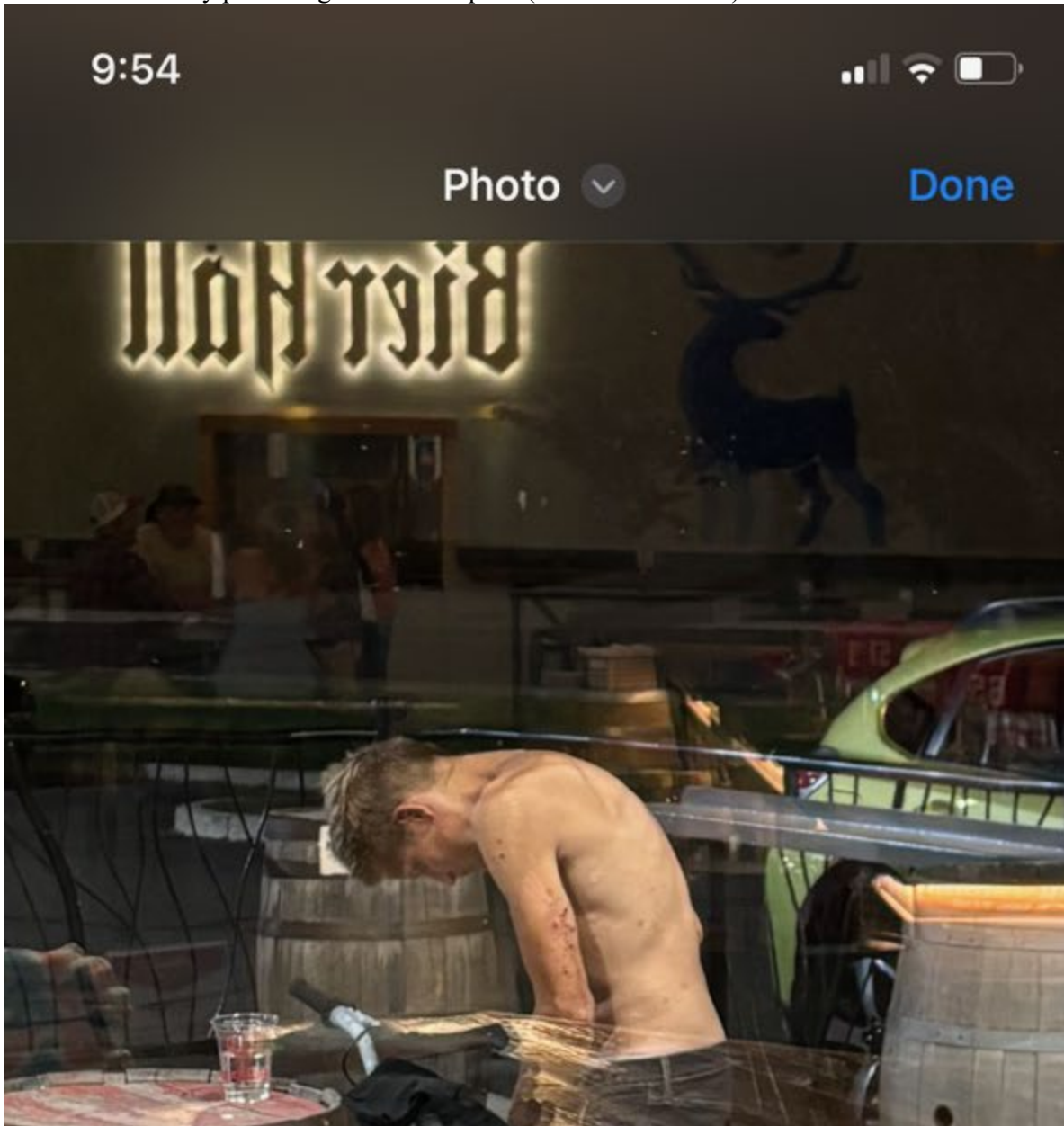

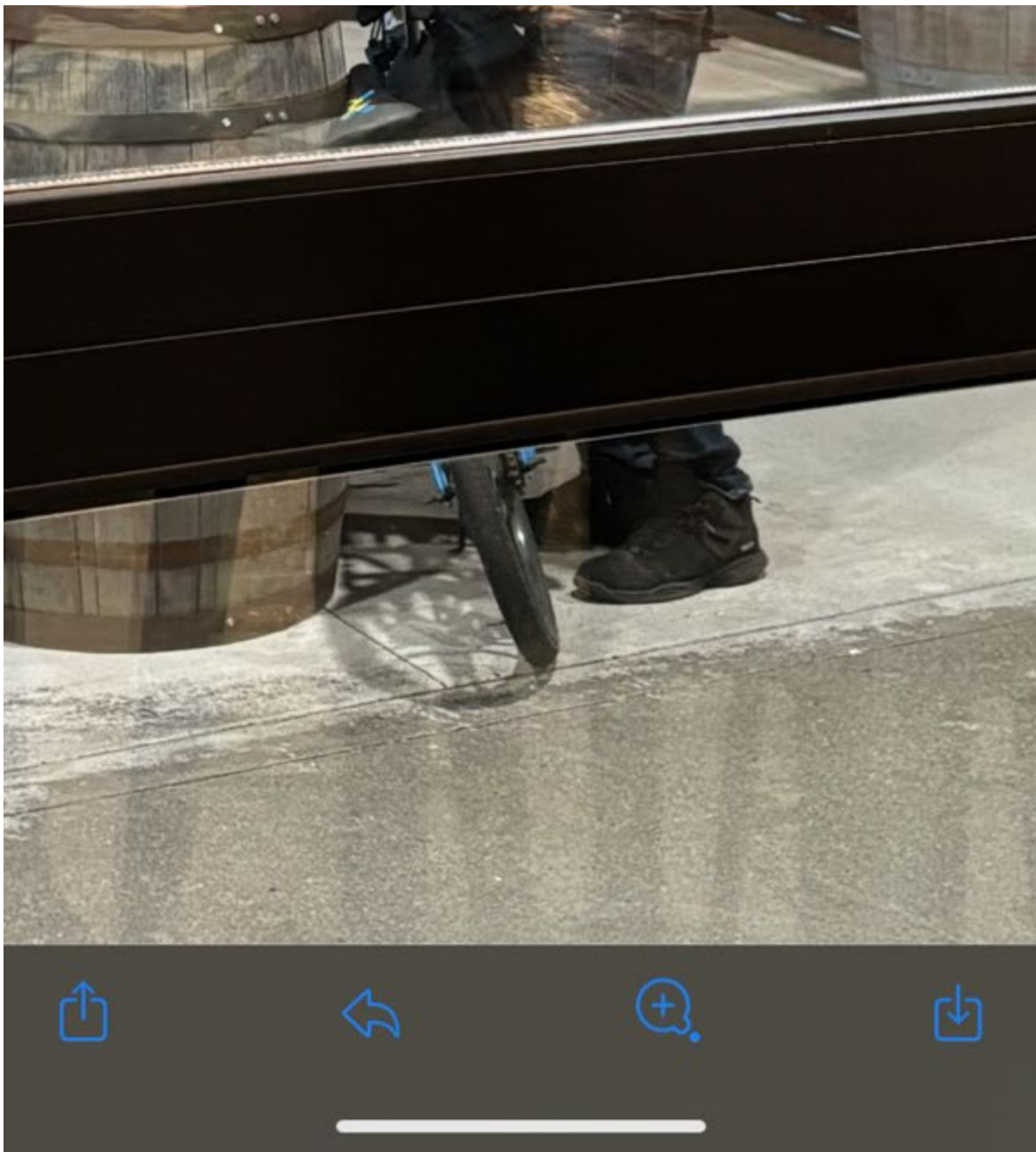

>>

>>

>> We appreciate any public safety that you can provide to take criminals off the street.

>>

>> Sincerely,

>>

>> John Bryant

>> Owner

>> No-Li Brewhouse

>> Sent from my iPhone

From: [Chuck Murphy](#)
To: [Downey, KayCee](#)
Subject: RE: South Logan TOD Update – City Council to Consider Code Amendments Aug. 12
Date: Friday, July 19, 2024 2:40:00 PM

[CAUTION - EXTERNAL EMAIL - Verify Sender]

Thank you Kaycee. I appreciate your outreach on this. Based upon a quick review, the final report from Gonzaga's perspective seems consistent with earlier draft versions.

Chuck

From: Downey, KayCee <kdowney@spokanecity.org>
Sent: Friday, July 19, 2024 9:33 AM
To: Chuck Murphy <murphyc@gonzaga.edu>; Ken Sammons <sammons@gonzaga.edu>
Subject: FW: South Logan TOD Update – City Council to Consider Code Amendments Aug. 12

You don't often get email from kdowney@spokanecity.org. [Learn why this is important](#)

Good morning,

I wanted to make sure both of you were aware of the latest update for the South Logan TOD Project. The South Logan TOD Implementation [code amendments](#) will be before City Council for a public hearing on **August 12**.

The [land use and zone changes](#) are going through the 2023/2024 Comprehensive Plan Amendment process, which is anticipated to be before Plan Commission for a public hearing sometime in September. There will be more updates as we get closer and can verify dates.

Please let me know if you have any questions.

Thank you,
KayCee



KayCee Downey, AICP (she/her) | City of Spokane | Planner II | Planning & Economic Development
509.625.6194 | dept. 509.625.6500 | kdowney@spokanecity.org | spokanecity.org

Questions about a Middle Housing project? Schedule an appointment with the [Middle Housing Support Team](#) for assistance navigating the development process.

This email is subject to Washington State Public Records Act, Chapter 42.56 RCW, and may therefore be subject to public disclosure.

From: City of Spokane Planning <southlogantod@spokanecity.org>

Kimbrell, Tyler

From: Pablo Frias <pablo.a.frias21@gmail.com>
Sent: Friday, August 2, 2024 5:44 PM
To: Planning & Development Services South Logan TOD Project; City Council Members and Staff
Subject: Spokane Urban Reform Package

[CAUTION - EXTERNAL EMAIL - Verify Sender]

To whom it may concern,

I strongly support the direction that downtown Spokane, and Spokane in general, is taking to address the lack of pedestrian and cycling options as well as removing many barriers that have plagued the city. Having lived in Europe for several years, I am a passionate advocate for making cities and towns more pedestrian and cyclist-friendly. The benefits are clear: reduced noise pollution, fewer accidents, and improved quality of life through healthier lifestyles and a stronger sense of community.

Spokane could greatly benefit from designating one or two downtown streets exclusively for pedestrians. Many European towns have extensive areas devoted solely to pedestrians, which is a major reason why people enjoy visiting Disney theme parks—no vehicle traffic means freedom to walk and enjoy the park without the fear of accidents or pollution.

Another effective European strategy is the use of speed cameras, which significantly deter speeding and enhance safety. Additionally, the revenue generated from speed cameras can fund more pedestrian-friendly projects.

While I appreciate the growing popularity of roundabouts, the current number is insufficient. The advantages are well-documented, and we could use many more.

Most bike paths in Spokane are currently dangerous, requiring cyclists to navigate vehicular traffic, which discourages cycling and decreases safety.

The presence of buses in the city is beneficial, but when buses are stuck behind personal vehicle traffic, the advantages of public transportation diminish. Dedicated bus lanes would allow buses to traverse the city more efficiently, encouraging higher ridership. Additionally, creating park-and-ride facilities outside the city would provide more options for commuters.

These examples are commonplace in numerous European cities. Having lived in the UK, Germany, and Spain, and having visited many other countries, I can attest to the exceptional quality of their transportation systems compared to ours. Our car-dependent culture fosters obesity, reduces social interaction, increases pedestrian fatalities, and heightens anxiety. While many places in the U.S. suffer from these issues, Spokane has the opportunity to continue progressing in a better direction with more aggressive policies.

Sincerely,

Pablo



South Logan TOD Implementation Proposed Text Amendment Tracker

The text amendment tracking sheet provides a summary of proposed changes in each section of the Spokane Municipal Code. The text amendment tracking sheet does not replace reviewing the draft code text amendments as there may be additional details and/or minor changes that were not captured in this document.

Existing SMC Section	New SMC Section	Description of Change
SMC 17A.20.160 “P” Definitions		
Section 17A.20.160 “P” Definitions		<ul style="list-style-type: none"> ○ Added “PAO Responsible Official” to the definitions ○ Added “Planned Action” to the definitions
SMC 17C.111.205 Development Standards Tables		
Section 17C.111.205 Development Standards Tables Table 17C.111.205-2 Building and Siting Standards		<ul style="list-style-type: none"> ○ Increased standard height in RMF to 55-feet from 40-feet ○ Increased standard height in RHD to 75-feet from 40-feet ○ Reduced open space requirements in RMF and RHD depending on unit size, with the minimum being 48 sq. ft. per unit. Prior to housing code changes passed in January 2024, the minimum open space required was 48 sq. ft. ○ Reduced open space requirements in RHD for sites 20,000 sq. ft. or less, allowing a minimum of 36 sq. ft. ○ Added residential units with a continuous pedestrian route to a public park within 800 feet to have a maximum open space requirement per unit of 36 sq. ft.

SMC 17C.111.230 Height

Section 17C.111.230 Height		<ul style="list-style-type: none">○ Replaced the permitted height of 70-feet to 75-feet, allowing for the increased height envisioned for podium development○ Properties currently zoned -70 will not increase to 75-feet with this amendment; a rezone of the property would be required○ Changed the transition adjacent to R1 and R2 from 1:2 to 2:1, reducing the slope to make the permitted height feasible in the more intense zones○ Increased starting height from 30-feet to 40-feet○ Removed height exception of an extra 15-feet for RMF/RHD zones with a maximum height of 40-feet; unnecessary with base height increase proposed in SMC 17C.111.205
----------------------------	--	--

SMC 17C.111.420 Open Spaces

(section name changed from Outdoor Spaces)

Section 17C.111.410 Outdoor Spaces	Section 17C.111.410 Open Spaces	<ul style="list-style-type: none">○ Rename outdoor spaces to open spaces to more accurately reflect spaces already permitted to meet minimums○ Reorganized open space standards by private and common space, rather than ground floor and upper floor space○ Emphasized that open space must be useable and accessible to residents of the development○ Add enclosed pet areas, children’s play areas, and community gardens as permitted common open space amenities○ Removed unnecessary and non-descriptive photographs found in the code
---------------------------------------	------------------------------------	--

SMC 17C.120.220 Height

Section 17C.120.220 Height		<ul style="list-style-type: none"> ○ Replaced the permitted height of 70-feet to 75-feet, allowing for the increased height envisioned for podium development ○ Properties currently zoned -70 will not increase to 75-feet with this amendment; a rezone of the property would be required ○ Changed the transition adjacent to R1 and R2 from 1:2 to 2:1, reducing the slope to make the permitted height feasible in the more intense zones ○ Increased starting height from 30 ft to 40ft
SMC 17C.122 Center and Corridor Zones		
Section 17C.122.070 Center and Corridor Zone Allowed Uses		<ul style="list-style-type: none"> ○ Amended to not allow drive-through businesses in CC1 ○ Drive-through businesses still allowed in CC2 and CC3 except for along designated pedestrian streets ○ Removed unnecessary footnote language
Section 17C.122.080 Floor Area Ratios (FAR)		<ul style="list-style-type: none"> ○ REPEALED ○ Floor Area Ratio (FAR) standards relocated to 17C.122.230
Section 17C.122.090 Public Amenities Allowing Bonus FAR	Section 17C.120.090 Public Amenities Allowing Bonus Height	<ul style="list-style-type: none"> ○ Modified to allow bonus height instead of FAR ○ Allows for 15 feet of additional height if all parking is within an entirely below-grade structure, behind the building, or in an above-ground parking garage; or if at least 20% of the residential units are Affordable; or if public art of 1% of development costs is provided ○ Removed other bonus incentives for public spaces and public art
Section 17C.122.100 Maximum Building Height		<ul style="list-style-type: none"> ○ REPEALED ○ Height standards relocated to 17C.122.210
Section 17C.122.110 Setbacks and Required Sidewalk Width		<ul style="list-style-type: none"> ○ REPEALED ○ Setbacks and sidewalk widths relocated to 17C.122.240 and 17C.122.250

	Section 17C.122.200 Development Standards Table	<ul style="list-style-type: none"> ○ NEW SECTION ○ Consolidates development standards tables ○ Increases heights in NC, DC, and EC from 40ft/55ft/150ft to 55ft/75ft/150ft ○ Removes maximum FAR standards ○ Includes minimum FAR standards in District Centers and Employment Centers
	Section 17C.122.210 Height	<ul style="list-style-type: none"> ○ NEW SECTION ○ Height standards relocated from 17C.122.210 ○ Clarifies how height is measured for code consistency
	Section 17C.122.220 Height Transition	<ul style="list-style-type: none"> ○ NEW SECTION ○ Height Transition standards relocated from 17C.122.100 ○ Changed the transition adjacent to R1 and R2 from 1:2 to 2:1, reducing the slope to make the permitted height feasible in the more intense zones ○ Increased starting height from 30 ft to 40ft
	Section 17C.122.230 Floor Area Ratio	<ul style="list-style-type: none"> ○ NEW SECTION ○ Floor Area Ratio (FAR) standards relocated from 17C.122.070 ○ Explains how FAR is measured.
	Section 17C.122.240 Setbacks	<ul style="list-style-type: none"> ○ NEW SECTION ○ Setback standards relocated from 17C.122.110
	Section 17C.122.250 Sidewalks	<ul style="list-style-type: none"> ○ NEW SECTION ○ Sidewalk standards relocated from 17C.122.110

SMC 17C.122T Center and Corridor Zone Development Tables

Chapter 17C.122T Center and Corridor Zone Development Tables		<ul style="list-style-type: none"> ○ REPEALED ○ Development tables consolidated and relocated to 17C.122.200
--	--	--

SMC 17C.123 Form Based Code Zones

Section 17C.123.010 Purpose		<ul style="list-style-type: none"> ○ Minor language updates to reflect the Transit-Oriented Development (TOD) emphasis of the South Logan area
-----------------------------	--	---

Section 17C.123.020 Code Organization	17C.123.020 Context Area and Shopfront Designations	<ul style="list-style-type: none"> ○ Reorganization of regulations found in 17C.123.030 ○ Consolidation of the four Context Areas in the Hamilton Form-Based Code to one Context Area ○ Removal of Street Types for less variable development patterns; replaced with Shopfront designations for high interest street corners
Section 17C.123.030 Regulating & Street Section Plans	17C.123.030 Building Form	<ul style="list-style-type: none"> ○ Reorganization of regulations found in 17C.123.040 ○ Created Table 17C.123.030-1 to better illustrate development regulations outside of graphics ○ Implemented maximum setback in place of build-to lines for code consistency ○ Established exception to maximum setback for public plazas
Section 17C.123.040 Land Use, Height, Placement and Parking	Section 17C.123.040 Permitted Uses	<ul style="list-style-type: none"> ○ NEW SECTION ○ Changed from a list of prohibited uses to a table of permitted uses to reflect standard organization of code and assist in the implementation and transparency of the Hamilton Form-Based Code
Section 17C.123.050 Streetscape Requirements	Section 17C.123.050 Parking and Pedestrian Connectivity	<ul style="list-style-type: none"> ○ Reorganization of regulations found in 17C.123.040
Section 17C.123.060 Architectural Requirements	Section 17C.123.060 Streetscape Requirements	<ul style="list-style-type: none"> ○ Reorganization of regulations found in 17C.123.050 ○ Consolidated regulations to one Context Area and the Shopfront Designation
Section 17C.123.070 Additional Requirements	Section 17C.123.070 Design Standards	<ul style="list-style-type: none"> ○ Reorganization of regulations found in 17C.123.050 ○ Made some regulations more objective by providing specific guidance meeting the intent of the design standard ○ Incorporated guidelines consistent with the South Logan TOD Subarea Plan
Section 17C.123.080 Building Type Catalogs	17C.123.080 Additional Requirements	<ul style="list-style-type: none"> ○ Removed the visual character catalogs as they did not fully encapsulate the permitted designs

		<p>within the Hamilton Form-Based Code and did not include enforceable regulations</p> <ul style="list-style-type: none"> ○ Reorganization of regulations found in 17C.123.070 ○ Removed allowance of barbed wire within the Hamilton Form-Based Code ○ Permitted accessory outdoor sales so long as the Clear Pedestrian Zone and Buffer Zones are maintained
SMC 17C.230 Parking and Loading		
Section 17C.230.120 Maximum Required Parking Spaces		<ul style="list-style-type: none"> ○ Modified CC parking standards, removing minimum parking requirements but keeping maximum parking standards
Section 17C.230.130 Parking Exceptions		<ul style="list-style-type: none"> ○ Text changes aligning with the modified parking table in 17C.230.120 ○ Remove minimum parking in Center and Corridor, Downtown, and Form Based Code zones ○ Changes to make clear when and where parking requirements apply to residential units and Accessory Dwelling Units for improved code useability
SMC 17C.300 Accessory Dwelling Units		
Section 17C.300.130 Development Standards		<ul style="list-style-type: none"> ○ Text changes to align with 17C.230.130 Parking Exceptions ○ Proposed change made for code consistency
SMC 17C.420 South Logan Planned Action Ordinance		
<i>(please note, the chapter number may change before adoption)</i>		
	Section 17C.420.010 Purpose	<ul style="list-style-type: none"> ○ NEW SECTION ○ Identifies the purpose of the South Logan TOD Planned Action Ordinance
	Section 17C.420.015 Procedures and Criteria for Evaluating and Determining Projects as Planned Action	<ul style="list-style-type: none"> ○ NEW SECTION ○ Identifies the Planned Action Area ○ Identifies the South Logan TOD Final EIS as the regulating environmental analysis for the Planned Action Ordinance

		<ul style="list-style-type: none"> ○ Identifies thresholds and criteria to qualify for the Planned Action Ordinance ○ Reinforces the requirement of an Inadvertent Discovery Plan and the process for Historic properties ○ Exempts projects subject to the Shoreline Master Program from qualifying ○ Exempts drive thru facilities from qualifying
	Section 17C.420.020 Planned Action Permit Process and Application	<ul style="list-style-type: none"> ○ NEW SECTION ○ Identifies the permit and application process for the Planned Action Ordinance
	Section 17C.420.025 Monitoring and Review	<ul style="list-style-type: none"> ○ NEW SECTION ○ Establishes a mandate for the City to monitor the progress of development in the Planned Action area and to review the state of the Planned Action Ordinance no later than 5 years from the effective date



Agenda Sheet for City Council:

Committee: Urban Experience **Date:** 07/08/2024

Committee Agenda type: Discussion

Date Rec'd

7/8/2024

Clerk's File #

ORD C36553

Cross Ref #

Project #

Council Meeting Date: 07/22/2024

Submitting Dept

PLANNING & ECONOMIC

Bid #

Contact Name/Phone

KAYCEE X6194

Requisition #

Contact E-Mail

KDOWNEY@SPOKANECITY.ORG

Agenda Item Type

First Reading Ordinance

Council Sponsor(s)

ZZAPPONE KKLITZKE JBINGLE

Agenda Item Name

0650 HAMILTON FORM-BASED CODE UPDATE ASSOC. WITH S LOGAN TOD

Agenda Wording

Hamilton Form-Based Code update to SMC Chapter 17C.123 for South Logan TOD Implementation to support transit-oriented development.

Summary (Background)

The South Logan Transit-Oriented Development (TOD) Plan, adopted by resolution on January 29, 2024, provides recommendations to support more connectivity and livability for the community, businesses, and organization in South Logan. The proposed Hamilton Form-Based Code update to amend SMC Chapter 17C.123 align with the goals and recommendations of the South Logan TOD Plan and the City of Spokane Comprehensive Plan. The proposed amendments include consolidating the context areas and street

Lease? NO

Grant related? NO

Public Works? NO

Fiscal Impact

Approved in Current Year Budget? N/A

Total Cost

\$

Current Year Cost

\$

Subsequent Year(s) Cost

\$

Narrative

The S. Logan TOD Plan and FEIS, adopted by resolution on January 29, 2024, was funded through the TOD Implementation grant program via the WA Department of Commerce. Implementation of the S. Logan TOD Plan relied on on-going and regular staff resources.

Amount

Budget Account

Neutral

\$

#

Select

\$

#

Select

\$

#

Select

\$

#

Select

\$

#

Select

\$

#



Continuation of Wording, Summary, Approvals, and Distribution

Agenda Wording

Summary (Background)

types of the Form-Based Code, identifying Shopfront designations, removing parking minimums, and general reorganization. For the full code amendments please visit: <https://my.spokanecity.org/projects/south-logan-transit-oriented-development-project/>

Approvals

<u>Dept Head</u>	MACDONALD, STEVEN
<u>Division Director</u>	GARDNER, SPENCER
<u>Accounting Manager</u>	ORLOB, KIMBERLY
<u>Legal</u>	SCHOEDEL, ELIZABETH
<u>For the Mayor</u>	PICCOLO, MIKE

Additional Approvals

Distribution List

smacdonald@spokanecity.org	kdowney@spokanecity.org
sgardner@spokanecity.org	tblack@spokanecity.org
tkimbrell@spokanecity.org	amccall@spokanecity.org

Committee Agenda Sheet

Urban Experience Committee

Committee Date	July 8, 2024
Submitting Department	Planning & Economic Development
Contact Name	KayCee Downey
Contact Email & Phone	kdowney@spokanecity.org , x6194
Council Sponsor(s)	<u>CM Zappone, CM Klitzke and CM Bingle</u>
Select Agenda Item Type	<input type="checkbox"/> Consent <input checked="" type="checkbox"/> Discussion Time Requested: 5 minutes
Agenda Item Name	Hamilton Form-Based Code Update Associated with South Logan TOD Implementation
Proposed Council Action	<input checked="" type="checkbox"/> Approval to proceed to Legislative Agenda <input type="checkbox"/> Information Only
Summary (Background) *use the Fiscal Impact box below for relevant financial information	<p>The South Logan Transit-Oriented Development (TOD) Plan, adopted by resolution on January 29, 2024, provides recommendations to support more connectivity and livability for the community, businesses, and organization in South Logan.</p> <p>The proposed Hamilton Form-Based Code update to amend SMC Chapter 17C.123 align with the goals and recommendations of the South Logan TOD Plan and the City of Spokane Comprehensive Plan.</p> <p>The proposed amendments include consolidating the context areas and street types of the Form-Based Code, identifying Shopfront designations, removing parking minimums, and general reorganization.</p> <p>For the full code amendments please visit: https://my.spokanecity.org/projects/south-logan-transit-oriented-development-project/</p>
Fiscal Impact	
Approved in current year budget? <input type="checkbox"/> Yes <input type="checkbox"/> No <input checked="" type="checkbox"/> N/A Total Cost: <i>Click or tap here to enter text.</i>	
Narrative: The South Logan TOD Plan and FEIS, adopted by resolution on January 29, 2024, was funded through the Transit-Oriented Development Implementation (TODI) grant program through the WA Department of Commerce. Implementation of the South Logan TOD Plan relied on on-going and regular staff resources.	
Funding Source <input type="checkbox"/> One-time <input type="checkbox"/> Recurring <input checked="" type="checkbox"/> N/A Specify funding source: <i>Select Funding Source*</i> Is this funding source sustainable for future years, months, etc? <i>Click or tap here to enter text.</i>	
Expense Occurrence <input type="checkbox"/> One-time <input type="checkbox"/> Recurring <input checked="" type="checkbox"/> N/A Other budget impacts: (revenue generating, match requirements, etc.)	
Operations Impacts (If N/A, please give a brief description as to why)	
<i>What impacts would the proposal have on historically excluded communities?</i> The proposed text amendments are intended to support high quality transit, increase housing capacity and diversity, and promote affordability along the City Line bus rapid transit in the South Logan area and throughout	

Center and Corridor and higher intensity residential areas throughout Spokane. By focusing on development along transit lines and removing identified barriers to successful projects, the proposals are intended to support a diversity of uses and housing options near existing multimodal transportation options.

How will data be collected, analyzed, and reported concerning the effect of the program/policy by racial, ethnic, gender identity, national origin, income level, disability, sexual orientation, or other existing disparities?

The South Logan TOD Plan reviewed and analyzed environmental and social impacts of planned development and development alternatives as part of the process, following the guidance of the HEAL Act. An analysis of existing conditions established a baseline to inform the project with data on demographics, socioeconomics, housing and market conditions, land use and zoning, and infrastructure needs. The proposals are implementing the adopted Plan with no additional data collection.

How will data be collected regarding the effectiveness of this program, policy, or product to ensure it is the right solution?

The South Logan TOD Plan was developed after a 20-month community engagement process that sought input from residents, businesses, institutions, agency partners, and other subject matter experts. The proposals are implementing the recommendations of the adopted Plan. Additional community outreach and engagement occurred after draft ordinances were available to verify effectiveness of the implementation.

Describe how this proposal aligns with current City Policies, including the Comprehensive Plan, Sustainability Action Plan, Capital Improvement Program, Neighborhood Master Plans, Council Resolutions, and others?

The South Logan TOD Project is aligned with many City policies to better connect land use and transportation, expand and increase the housing supply including middle housing and affordable housing, and promote anti-displacement and equitable outcomes. This includes the Comprehensive Plan (Housing Chapter), Housing Action Plan, Sustainability Action Plan, and Transit-Oriented Development Framework Study, and Logan Neighborhood Identity Plan. The proposals are implementing the South Logan TOD Plan, which was adopted by resolution on January 29, 2024 after being determined to meet all relevant policies and plans.

ORDINANCE NO. C36553

AN ORDINANCE relating to the Hamilton Form-Based Code amending Spokane Municipal Code (SMC) Chapter 17C.123 Form Based Code Zones.

WHEREAS, in 2021, the Washington State Legislature appropriated \$2.5 million for cities to facilitate transit-oriented development in areas with light rail or fixed rail systems, bus rapid transit, high-frequency bus service or park and ride lots; and

WHEREAS, the City of Spokane was one of 11 communities that received the Transit-Oriented Development Implementation (TODI) grant for \$250,000 from the Washington Department of Commerce in 2021 to facilitate transit-oriented development and increase residential capacity in areas of high-capacity transit; and

WHEREAS, the City of Spokane prepared the Transit-Oriented Development (TOD) Framework Action Plan, adopted by resolution in May 2022 under RES 2022-0039, that identifies strategies best suited to Spokane for supporting TOD along new High-Performance Transit lines, including a focus on South Logan; and

WHEREAS, the City provided opportunities for meaningful public involvement and review in the South Logan TOD Plan and EIS process, including a community meeting consistent with RCW 43.21C.440; has considered all comments received; and, as appropriate, has modified the proposal or mitigation measures in response to comments, resulting in the Preferred Alternative analyzed in the FEIS; and

WHEREAS, the *Final South Logan TOD Plan and Final Environmental Impact Statement (FEIS)* was published on November 30, 2023 for final consideration; and

WHEREAS, on January 29, 2024 Spokane City Council adopted by resolution (RES 2024-0015) the Final South Logan TOD Plan and FEIS as a declaration of the subarea's desired future condition; and

WHEREAS, in order to facilitate the higher intensity residential development envisioned in the Plan, the adopted Final South Logan TOD Plan called for strategic adjustments to the Hamilton Form-Based Code to enhance transit-oriented development opportunities, while retaining design measures to ensure that development is pedestrian-oriented and contributes to the neighborhood; and

WHEREAS, on April 29, 2024, the Washington State Department of Commerce and appropriate state agencies were given the required 60-day notice of the City's intent to adopt updated development regulations; and

WHEREAS, the Spokane Plan Commission held public workshops on the provisions in this ordinance on March 13, April 10, April 24, May 22, and June 12 of this year; and

WHEREAS, a SEPA Determination of Nonsignificance and Checklist were issued by Planning Services on June 12, 2024; and

WHEREAS, prior to the Plan Commission public hearing, a legal notice was published in the *Spokesman-Review* on June 12 and June 19, 2024; and

WHEREAS, on June 19, 2024, the Planning Department staff finalized their Staff Report to the Spokane Plan Commission recommending approval of the provisions of this ordinance; and

WHEREAS, on June 26, 2024, the Spokane Plan Commission held a public hearing on the provisions of this ordinance and unanimously voted to recommend approval with conditions, as outlined in the Findings of Fact, Conclusions, and Recommendation signed June 28, 2024; and

WHEREAS, the City Council adopts the recitals set forth herein as its findings and conclusions in support of its adoption of this ordinance.

NOW, THEREFORE, the City of Spokane does ordain:

Section 1. That SMC Section 17C.123.010 is amended to read as follows:

Section 17C.123.010 Purpose

~~((The form-based zoning categories implement the centers and corridors goals and policies and land use map designations of the comprehensive plan. This form-based code))~~ The Hamilton Form-Based Code (FBC) is designed to foster an economically vibrant, walkable, mixed-use environment along the Hamilton Street corridor within the boundaries of the code. This code regulates land development by setting careful and coherent controls on building form, coupled with performance-based parameters relative to building use and ~~((density))~~ intensity. ~~((This greater emphasis on physical form is intended to produce safe, attractive and enjoyable public spaces, including a healthy mix of uses.))~~ Through emphasis on physical form, the Hamilton FBC promotes connectivity and livability with safe, accessible public spaces, a healthy mix of uses, and access to transit.

~~((The FBC is a pilot program and is configured as a plug-in set of regulations, replacing existing zoning and design guidelines within the FBC Limits. This pilot program is consistent with the Logan Identify Plan. All code provisions expressed herein present development requirements unless otherwise indicated, including information preceded by the word "Guidelines." Additional, specific City of Spokane standards may be required as referenced.))~~

Where not otherwise regulated within this Chapter, development within the Hamilton FBC area shall meet all applicable regulations of the Spokane Municipal Code.

Section 2. That SMC Section 17C.123.020 is amended to read as follows:

17C.123.020 ((Code Organization)) Context Area and Store Front Designations

~~((Using this code: Criteria for development within the code boundaries is expressed in six sections. Use of the FBC, relating to each of these sections, is described below:~~

~~A. Regulating & Street Section Plans.~~

~~Find the property of interest, noting its location relative to the “Context Areas” established by the Regulating Plan, as well as the location of any “Shopfront Streets” abutting the property. These elements direct many of the allowances provided in the FBC.~~

~~B. Height, Placement & Coverage.~~

~~Using criteria from the Regulating Plan, note the allowed maximum building heights; build-to lines; minimum building frontages, and impervious surface coverage allowances detailed in this section.~~

~~C. Parking Criteria & Site Access.~~

~~Using criteria from the Regulating Plan and the Street Section Plan, note the various allowances regarding off-street surface parking, lot placement, lot and site lighting.~~

~~D. Streetscape Requirements.~~

~~Using type criteria from the Street Section Plan, note the basic configuration and feature specifications for sidewalks and pedestrian buffer zones within the FBC Limits.~~

~~E. Architectural Requirements.~~

~~Using criteria from the Regulating Plan, note the various façade treatments, screening, detailing and other requirements specific to the appearance and public-realm function of buildings.~~

~~F. Additional Requirements.~~

~~This section identifies additional requirement not covered by the HFBC.~~

~~G. Building Type Catalogs.~~

~~This section provides a visual catalog of desired building characteristics.))~~

The Hamilton Form-Based Code (FBC) area is regulated by a Context Area. Identified intersections are assigned Shopfront designations, which include additional requirements and allowances.

A. Context Area.

Context Area 1 (CA1) is the implementing zone of the Hamilton FBC. Figure 17C.123.010-A illustrates the location of the C1 zoning.



Figure 17C.123.010-A
Context Area Map

B. Shopfront Designations.

Shopfront designations are assigned to key intersections within the Hamilton FBC to allow for increased height and pedestrian-oriented design. Figure 17C.123.010-B illustrates the location of the Shopfront designations.



**Figure 17C.123.010-B
Shopfront Designations**

Section 3. That SMC Section 17C.123.030 is amended to read as follows:

17C.123.030 ((Regulating & Street Section Plans)) Building Form

~~((This section provides and describes the FBC Regulating Plan and Street Section Plan – two map illustrations showing the location and limits of various features and physical characteristics required under this code. The Regulating Plan also indicates placement and extents of “Shopfront Street” areas, triggering specific use, building placement and other requirements.~~

A. Regulating Plan.

~~The Regulating Plan for the FBC is included here as Figure 17C.123.030-1, and provides the organizing framework for many of the requirements described herein. The Regulating Plan divides land within the code boundaries into four distinctive context areas and identifies shopfront streets, listed and described as follows:~~

- ~~1. CA-1: Context Area 1 provides for and supports the most intense development patterns, generally allowing greater height and building intensities than other context areas. CA-1 is intended to grow as a mixed-use center and focal point for the neighborhood and corridor, supporting significant commercial offerings, service activities, and high-density housing.~~

2. CA-2: Context Area 2 provides for and supports mid-range development intensities, allowing somewhat lesser height and building intensities than CA-1. CA-2 is intended to grow as a second-tier mixed-use center for the neighborhood and corridor, supporting commercial offerings, service activities, and high-density housing.
3. CA-3: Context Area 3 provides for and supports low to mid-range development intensities, allowing lesser height and building intensities than CA-1 or CA-2. CA-3 is intended to grow as a second-tier mixed-use area for the neighborhood and corridor, providing continuity along Hamilton by linking CA-1 and CA-2, while at the same time acting as a transition zone between the corridor environment and CA-4 and neighborhood areas immediately outside the HFBC Limits.
4. CA-4: Context Area 4 provides for and supports low to mid-range development intensities, allowing lesser height and building intensities than other context areas. CA-4 is intended to grow as a third-tier mixed-use area for the neighborhood and corridor, acting as a transition zone between the corridor environment and lower-density residential development immediately outside the FBC Limits. Though a mix of uses are allowed in CA-4, the area is envisioned as generally residential in scale and character.
5. Shopfront Street: provides for areas where specific uses, building placement, and other requirements apply. The shopfront street is generally applied to areas where business or retail use level with and directly along the public right-of-way is seen as critical.

B. Street Section Plan.

The Context Area Zones are complemented by the Street Section Plan which is included here as Figure 17C.123.030-2 and guides public and private development within the FBC Limits. The Street Section Plan defines four section types and describes amenities based upon the intended use, desired qualities, and community objectives. Right-of-ways shall not be vacated as the space is needed to incorporate the elements described in street designations below. Curb to property line and the sidewalk width shall not be reduced in order to allow for future Street Section elements. The four section types are listed and generally described in order of intensity, as follows:

1. Street Type 1 (Hamilton Street): Type 1 provides for and supports a mixed-use corridor environment (CA-1, CA-2, CA-3). Type 1 streets have wide, well-maintained sidewalks and pedestrian amenities to encourage strolling, walking, and shopping. They maintain a Planting Zone and Clear Pedestrian Zone on each side of the street.

2. ~~Street Type 2 (Mission Avenue): Type 2 provides for and supports a blend of mixed-use and residential environments (CA-1, CA-4). Type 2 serves existing east/west arterial needs, and includes a median with turn lanes (at Hamilton), a Planting Zone and Clear Pedestrian Zone on each side of the street.~~

3. ~~Street Type 3 (Includes Sinto, Sharp, Boone): Type 3 provides for and supports a mixed-use district environment (CA-2, CA-3, CA-4). Type 3 includes a Planting Zone and Clear Pedestrian Zone on each side of the street.~~

4. ~~Street Type 4 (Includes Augusta and Dakota): Type 4 provides for and supports an environment bridging between mixed-use and residential areas (CA-4). Type 4 includes a Planting Zone and Clear Pedestrian Zone on each side of the street.)~~

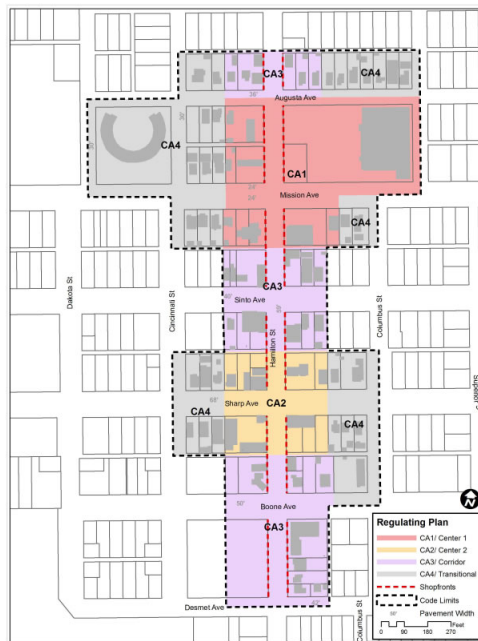

((Figure 17C.123.030-1 Regulating Plan for the Form Based Code))

[NOTE: Delete graphic above]

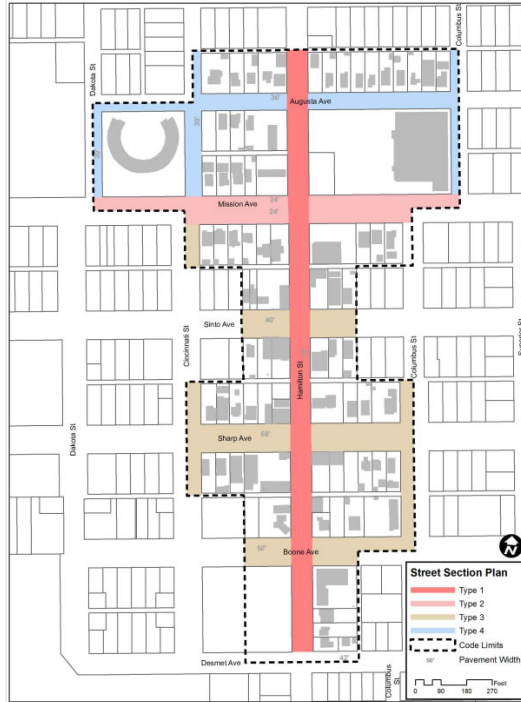

((Figure 17C.123.030-2 Street Section Plan for the Form Based Code))

[NOTE: Delete graphic above]

Within the Hamilton Form-Based Code (FBC), an emphasis is placed on building form and location in order to ensure a vibrant mixed-use environment that supports a range of transportation options, including transit, walking, and rolling.

A. Building Form Standards.

Table 17C.123.030-1 Hamilton FBC Building Form		
	<u>CA1</u>	<u>Shopfront</u>
<u>Maximum Height [1]</u>	<u>75 ft.</u>	<u>150 ft.</u>
<u>Impervious Surface Maximum</u>	<u>100%</u>	<u>100%</u>
Setbacks		
<u>Minimum Front Setback [2]</u>	<u>0 ft.</u>	<u>0 ft.</u>
<u>Maximum Front Setback [2] [3]</u>	<u>15 ft.</u>	<u>0 ft.</u> <u>10 ft. along Hamilton</u>
<u>Minimum Interior Side Lot Line</u>		<u>0 ft.</u>
<u>Minimum Interior Side Lot Line – adjacent to RMF or RHD</u>		<u>5 ft.</u>
<u>Minimum Rear</u>		<u>0 ft.</u>
<u>[1] Development of 70 feet or more shall meet all applicable requirements of SMC 17C.250 Tall Building Standards.</u>		

[2] When the existing sidewalk width is less than 12 feet, structures shall be allowed no closer than 12 feet from the back of the curb.

[3] A public plaza meeting all requirements of SMC 17C.123.030C(1)(2)(i) may extend the maximum setback an additional 10 feet

B. Height.

1. Building height is the vertical distance from the average grade to the highest point of the roof or structure.

2. Height Exceptions.

a. Pitched roofs may extend above the height limit, but if the space within the pitched roof is habitable, it shall only be used for residential purposes.

b. For flat roofs, open roof structures (pergolas, arbors) and architectural roof structures (turrets, etc.) may extend beyond the height limit by no more than 12'.

c. For flat roofs, enclosed roof structures (penthouses) may extend above the height limit by no more than 18' from the roof line if set back at least 20' from all street lot lines.

C. Building Placement.

1. Shopfront Designations.

a. Building placement along Shopfront Streets shall prioritize street corner locations, precluding the development of parking, open spaces, or other lot features at street corners.

b. Exceptions.

i. Public Plaza.

A plaza or courtyard, with a minimum area of four hundred square feet or two percent of the total interior floor space of the development, whichever is greater, may be located between a building and the street corner so long as the plaza:

a. is a level space accessible to the public;

b. is at least ten feet in width;

c. is within thirty inches of the grade of the sidewalk providing access to it;

d. has no more than sixty percent of the area covered in vegetation; and

- e. includes seating, pedestrian-scale lighting, decorative paving, and other pedestrian furnishings.

Section 4. That SMC Section 17C.123.040 is amended to read as follows:

17C.123.040 ((~~Land Use, Height, Placement and Parking~~)) Permitted Uses

~~((This section provides a broad range of allowable use categories within the Regulating Plan limits, specifying permitted and prohibited uses according to building story reflecting the development patterns expressed in the Regulating Plan. This section also regulates building height, placement, frontage and impervious surface coverage, specifying each within the Context Areas provided in the Regulating Plan and managing the transition between high-intensity mixed-use areas and low-intensity residential areas outside the limits of this form-based code. This section also regulates parking, parking lot location and treatment, and site lighting, consistent with the Regulating Plan. Conformance with these standards is critical to establishing the type of pedestrian and vehicular access patterns needed for the area to thrive as a vibrant, walkable district.~~

~~A. Use Provisions.~~

~~Use regulations are provided in figures 17.123.040-D through 17.123.040-G for all areas within the Regulating Plan. Uses deemed unsuitable for areas within the Regulating Plan area are specifically identified.~~

~~B. Building Height.~~

~~The height of buildings shall be measured from mean grade to top of cornice or roof eave and shall meet the specifications provided in figures 17.123.040-D through 17.123.040G. Building height measurements express regulatory standards.~~

- ~~1. Maximum height limits in CA-1, CA-2, and CA-3 are allowed only within 100' to 114' of the Hamilton right of way line to match the platting pattern along Hamilton. Beyond 100' from Hamilton, proposals shall be designed with respect for the height, scale and character of adjacent zone as described in Figure 17C.123.040-A:.)~~

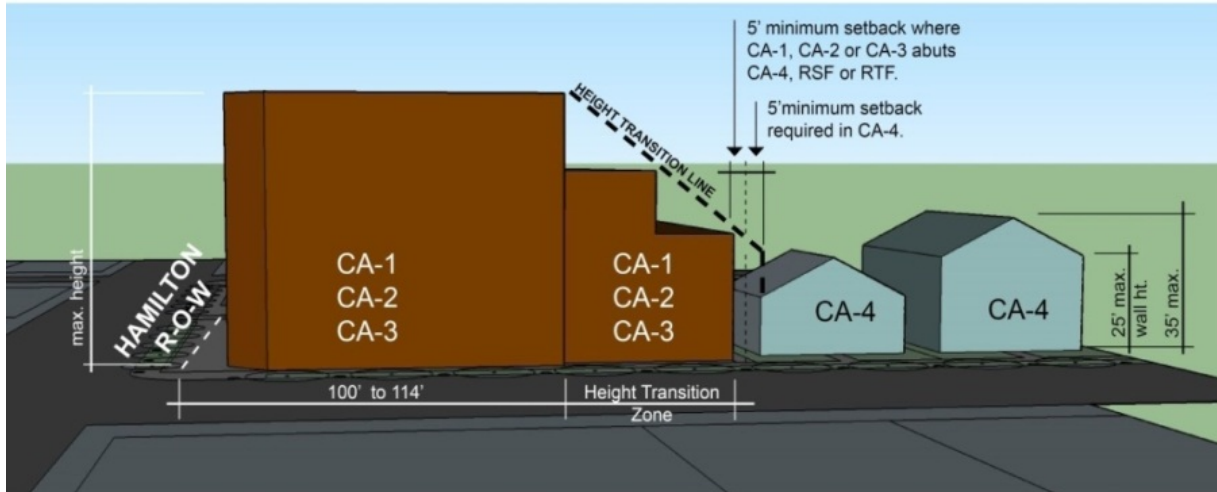

((Figure 17C.123.040A: The maximum height designation for CA-1, CA-2, CA-3 is allowed within 100' to 114' of the Hamilton right of way line to match the platting pattern along Hamilton. Beyond this point, the maximum height may not exceed a transition line to the maximum wall height allowed in the adjacent zone.))

[NOTE: Delete graphic above]

~~((C. Story listings are provided for reference purposes only, expressing typical outcomes for listed heights. Allowable height exceptions apply to the overall distance extending beyond the measured building height, as follows:~~

- ~~1. Pitched roofs may extend above the height limit, but if the space within the pitched roof is habitable, it shall only be used for residential purposes.~~
- ~~2. For flat roofs, Open Roof Structures (pergolas, arbors) and Architectural Roof Structures (turrets, etc.) may extend beyond the height limit by no more than 12'.~~
- ~~3. For flat roofs, enclosed roof structures (penthouses) may extend above the height limit by no more than 18' from the roof line if set back no less than 20'.~~

~~D. Shopfront Street Provisions.~~

~~Building placement along Shopfront Streets shall prioritize street corner locations, precluding the development of parking, open spaces or other lot features at street corners.~~

~~E. Impervious Surface Coverage.~~

~~Impervious surfaces shall not exceed the maximum impervious surface percentages (calculated on the basis of the lot) specified in Table 17C.123.040-4.))~~

((Table 17C.123.040-1 Impervious Surface Coverage				
	CA-1	CA-2	CA-3	CA-4
Maximum Impervious Surface	90%	80%	70%	50%))

~~(F.— Parking~~

- ~~1.— Off-Street Surface Parking: Off-street surface parking shall not be placed between the street right-of-way and the building fronting the street.~~
- ~~2.— Parking Space and Aisle Dimensions: Standards for parking space and aisle dimension can be found in SMC 17C.230.140.~~
- ~~3.— Bicycle Parking: Requirements for bicycle parking are found in SMC 17C.230.200. Bicycle parking provided in the streetscape can contribute to requirements in SMC 17C.230.200.~~
- ~~4.— Other Provisions: Additional parking requirements are stated in 17C.230 SMC, Parking and Loading. The FBC supersedes the location and amount requirements for parking; these standards are identified for each context area in figures 17.123.040-D through 17.123.040-G.~~

~~G.— Surface parking and site lighting.~~

~~Surface parking lot and site lighting shall contribute to the character and safety of the site and adjacent rights of way, while not disturbing adjacent properties. Surface lot and site lighting shall adhere to the following standards:—~~

- ~~1.— Lighting types – Pedestrian-scale fixtures shall be used for all lighting illuminating required Pedestrian Paths. Vehicle-scale fixtures may be used for general surface lot and site lighting. (See Figure 17C.123.040-B)~~
- ~~2.— Performance – Parking lot and site lighting shall provide adequate night visibility and security by distributing a minimum of two foot-candles to a maximum of six foot-candles of illumination at ground level. All lighting shall be shielded from producing off-site glare, directing light downward and away from adjacent properties.~~
- ~~3.— Driveways/Site Access – Driveway widths shall not exceed 24 feet, and curb cuts shall not exceed 30 feet for combined entry/exits.—~~
- ~~4.— Pedestrian Walkways – Within surface lots containing more than 30 parking stalls, pedestrian-friendly walkways shall be provided between the surface lots and building entrances. Pedestrian Paths shall be not less than five feet wide and be clearly defined, using at least two of the following:—~~
 - ~~a.— Six-inch vertical curbing~~
 - ~~b.— Textured paving, including across vehicle lanes~~

c. — Continuous landscaped area at a minimum of 3 feet wide on at least one side of the walkway

H. — Shopfront Street Provisions — If fronting on a Shopfront Street, above-ground parking structures shall provide continuous ground level commercial or office spaces and uses along the street, except at ingress and egress points into the structure. (See Figure 17C.123.040-C.)

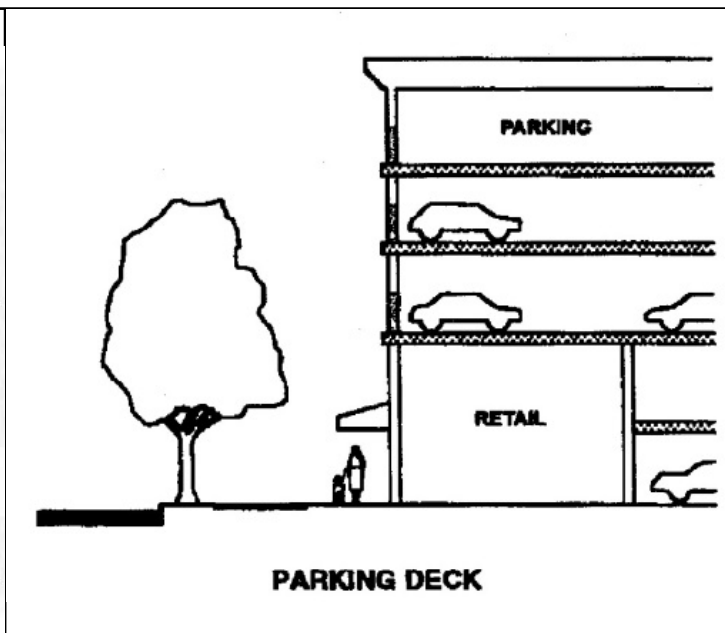
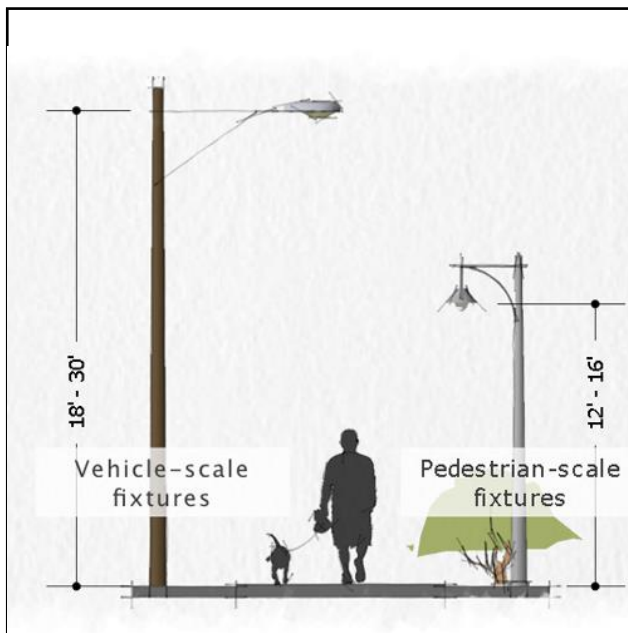

((Figure 17C.123.040-B: Unless otherwise specified, Vehicle Scale and Pedestrian Scale lighting fixtures must meet height criteria illustrated here.))

((Figure 17C.123.040-C: Parking garages (decks) along shopfront streets must provide ground-level retail, commercial or office space fronting the street.))

[NOTE: Delete graphic above]

[NOTE: Delete graphic above]

((I. — Regulatory Cutsheets — The information presented in the tables in figures 17.123.040-D through 17.123.040-G represent the regulations for height, parking, land uses, build-to-lines, and building frontage for all Context Areas.

J. — Figure 17C.123.040-H supplements the regulatory cutsheets by providing visual representation for build-to-lines, interior lot lines and other standards.))

Figure 17C.123.040-D
Context Area 1 (CA-1)

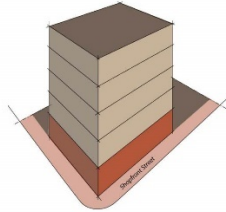

Images above are representational only and are not to be considered regulatory. The Rendering Plan, this chapter's general provisions and the information contained in this table to the right constitute the regulatory framework related to land use, height, parking, back to line, coverage and setbacks.

¹Build-to-line shall establish a 12-foot minimum and up to 22' maximum space from the back of the curb to the building along Street Type 1. If existing width is less than 12' structures shall be allowed no closer than 12' from the back of the curb.

Shoptown within 100' 114' of rear boundary line	66' (five stories)	Height max.
Beyond 100' 114' Hamilton property line	Transition Standards as identified in 17C.123.060-A	
Maximum surface parking	2 spaces/500' of floor area	Parking
Landscaping	See Section SMC 17C.230	
Location	To side or rear of building	Land uses
Additional Parking Requirements	See Sections: SMC 17C.230.100 SMC 17C.230.120 SMC 17C.230.130 SMC 17C.230.140 SMC 17C.230.200	
Residential, except where prohibited		Build-to-line
Prohibited uses	Non-residential all floors Single-family detached and townhouses Homesite, storage or warehouse Adult businesses Residential uses on adjacent street (ground floor) Structural parking on shoptown street (ground floor) Accessory uses Drive-through facilities	
Street Type 1	3'-6" - 17'-0"	Setback from
Street Type 2 and 4	0'	
When within 50' of CA-1	0'	Building coverage from
Street Type 3	Not applicable	
Alley	0'	Building coverage from
Interior lot line	0'	
Interior lot line if abutting CA-4	0'	
Street Type 1	80%	Building coverage from
Street Type 2	60%	
Street Type 3	N/A	
Street Type 4	0%	

[NOTE: Delete graphic above]

Figure 17C.123.040-E
Context Area 2 (CA-2)

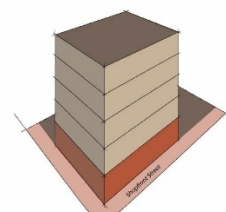

Images above are representational only and are not to be considered regulatory. The Rendering Plan, this chapter's general provisions and the information contained in this table to the right constitute the regulatory framework related to land use, height, parking, setbacks and setbacks.

¹Build-to-line shall establish a 12-foot minimum and up to 22' maximum space from the back of the curb to the building along Street Type 1. If existing width is less than 12' structures shall be allowed no closer than 12' from the back of the curb.

Shoptown within 100' 114' of rear boundary line	66' (five stories)	Height max.
Beyond 100' 114' Hamilton property line	Transition Standards as identified in 17C.123.060-A	
Maximum surface parking	2 spaces/500' of floor area	Parking
Landscaping	See Section SMC 17C.230	
Location	To side or rear of building	Land uses
Additional Parking Requirements	See Sections: SMC 17C.230.100 SMC 17C.230.120 SMC 17C.230.130 SMC 17C.230.140 SMC 17C.230.200	
Residential, except where prohibited		Build-to-line
Prohibited uses	Non-residential all floors Single-family detached and townhouses Homesite, storage or warehouse Adult businesses Residential uses on adjacent street (ground floor) Structural parking on shoptown street (ground floor) Accessory uses Drive-through facilities	
Street Type 1	3'-6" - 17'-0"	Setback from
Street Type 2	0'	
Street Type 3	0'	Building coverage from
When within 50' of CA-1	Not applicable	
Street Type 4	0'	
Alley	0'	Building coverage from
Interior lot line	0'	
Interior lot line if abutting CA-4	0'	
Street Type 1	80%	Building coverage from
Street Type 2	60%	
Street Type 3	N/A	
Street Type 4	N/A	

[NOTE: Delete graphic above]

Figure 17C.123.010-F
Context Area 3 (CA-3)

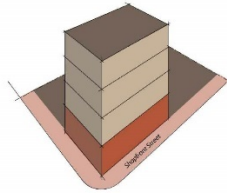

Images above are representational only and are not to be considered regulatory. The Regulatory Plan, this chapter's general provisions and the information contained in the table to the right control over the regulatory framework related to land use, height, parking, setbacks, building form, coverage and formage.

¹ If additional space shall be a 12' foot minimum and up to 22' maximum space from the back of the curb to the building along Street Type 1. If existing width is less than 17' meters shall be allowed no closer than 12' from the back of the curb.

Height of 2nd Floor property line	54' (3rd stories)	Height max.
Height of 100'-114' Floorline	Transitions Standards as identified in 17C.123.010-A	
Minimum surface parking	2 spaces/1000 of floor area	Parking
Landscaping	Section SMC 17C.200	
Location	To side or rear of building	Land Uses
Additional Parking Requirements	See Sections SMC 17C.205.100 SMC 17C.205.120 SMC 17C.205.130 SMC 17C.205.140 SMC 17C.205.200	
Residential, except where good-billed	Non Residential all floors	Build-to-line
Prohibited uses:	Single family detached (see Home Based); Accessory uses, storage or warehouse; Adult businesses; Incompatible area or program (see ground floor); Signs (see Signage, see sign form and format Book); Auto Repair/Shop; Drive Through facilities	
Street Type 1	None, 10' or 12'	5-setback line
Street Type 2	None	
Street Type 3, 4	0'	Building Formage min.
Where within SF of F.A.A. RSL or RTT	5'	
Alley	0'	
Interior lot line	0'	
Interior lot line, if abutting CA, RSL or RTT	5'	
Street Type 1	75%	
Street Type 2	60%	
Street Type 3	N/A	
Street Type 4	N/A	

[NOTE: Delete graphic above]

Figure 17C.123.040-F
Context Area 4 (CA-4)

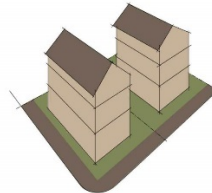

Images above are representational only and are not to be considered regulatory. The Regulatory Plan, this chapter's general provisions and the information contained in the table to the right control over the regulatory framework related to land use, height, parking, setbacks, building form, coverage and formage.

¹ Attached garage or carport entrance is required to be setback twenty feet from the property line.

² See SMC 17C.115.200E(1) setbacks regarding the use of front yard averaging.

Roof Height	35 feet	Height max.
Wall Height	25 feet	
Minimum off-street parking	1 space/ dwelling unit	Parking
Landscaping	See Section SMC 17C.200	
Location	See Section SMC 17C.200	Land Uses
Additional Parking Requirements	See Sections SMC 17C.205.100 SMC 17C.205.120 SMC 17C.205.130 SMC 17C.205.140	
Residential	Non-Residential (on ground floor)	Build-to-line
Non-Residential Development shall have a Residential Component from Residential and be no more than 1,000 of floor area		
Prohibited uses:	All residential categories; Parking garage (see attached garage or carport entrance); Accessory uses, storage or warehouse; Adult businesses; Incompatible area or program (see ground floor); Signage; Auto Repair/Shop; Drive Through facilities	5-setback line
Street Type 1	10'	
Street Type 2	10'	
Street Type 3	14'	
Street Type 4	15'	
Alley	0'	Building Formage min.
Interior lot line	5'	
Street Type 1	60%	
Street Type 2	60%	
Street Type 3	50%	
Street Type 4	None	

[NOTE: Delete graphic above]

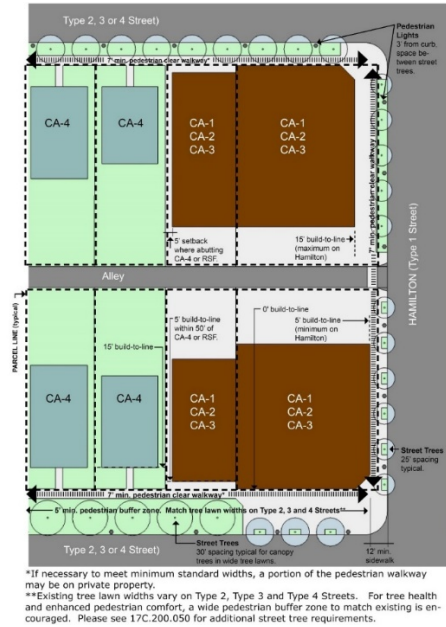

((Figure 17C.123.040-H Visual Diagram))

[NOTE: Delete graphic above]

A. Permitted Uses.

Uses permitted in the residential zones are listed in Table 17C.123.040-1 with a "P." These uses are allowed if they comply with the development standards and other standards of this chapter.

B. Limited Uses.

Uses permitted that are subject to limitations are listed in Table 17C.123.040-1 with an "L." These uses are allowed if they comply with the limitations as listed in the footnotes following the table and the development standards and other standards of this chapter. The paragraphs listed below contain the limitations and correspond with the bracketed [] footnote numbers from Table 17C.123.040-1.

C. Conditional Uses.

Uses that are allowed if approved through the conditional use review process are listed in Table 17C.123.040-1 with a "CU." These uses are allowed provided they comply with the conditional use approval criteria for that use, the development standards, and other standards of this chapter. The conditional use review process and approval criteria are stated in SMC 17C.320, Conditional Uses.

D. Uses Not Permitted.

Uses listed in Table 17C.123.040-1 with an "N" are not permitted. Existing uses in categories listed as not permitted are subject to the standards chapter 17C.210 SMC, Nonconforming Situations.

**Table 17C.123.040-1
Hamilton Form-Based Code Primary Uses**

Use is:	<u>CA1</u>	<u>Shopfront</u>
<u>P – Permitted</u>		
<u>N – Not Permitted</u>		
<u>L – Allowed, but special limitations</u>		
<u>CU – Conditional Use review required</u>		
<u>Residential Categories</u>		
<u>Group Living [1]</u>	<u>L/CU</u>	<u>L/CU</u>
<u>Single-Unit Residential Household Living</u>	<u>N</u>	<u>N</u>
<u>Other Residential Household Living</u>	<u>P</u>	<u>L [2]</u>
<u>Commercial Categories</u>		
<u>Adult Business</u>	<u>N</u>	<u>N</u>
<u>Commercial Outdoor Recreation</u>	<u>N</u>	<u>N</u>
<u>Commercial Parking</u>	<u>N</u>	<u>N</u>
<u>Structured Parking</u>	<u>P</u>	<u>L [3]</u>
<u>Drive-through Facility</u>	<u>N</u>	<u>N</u>
<u>Major Event Entertainment</u>	<u>P</u>	<u>N</u>
<u>Office</u>	<u>P</u>	<u>P</u>
<u>Quick Vehicle Servicing</u>	<u>N</u>	<u>N</u>
<u>Retail Sales and Service</u>	<u>P</u>	<u>P</u>
<u>Mini-storage Facilities</u>	<u>N</u>	<u>N</u>
<u>Vehicle Repair</u>	<u>N</u>	<u>N</u>
<u>Industrial Categories</u>		
<u>High Impact Uses</u>	<u>N</u>	<u>N</u>
<u>Industrial Service</u>	<u>N</u>	<u>N</u>
<u>Manufacturing and Production</u>	<u>N</u>	<u>N</u>
<u>Railroad Yards</u>	<u>N</u>	<u>N</u>
<u>Warehouse and Freight Movement</u>	<u>N</u>	<u>N</u>
<u>Waste-related</u>	<u>N</u>	<u>N</u>
<u>Wholesale Sales</u>	<u>N</u>	<u>N</u>
<u>Institutional Categories</u>		
<u>Basic Utilities</u>	<u>P</u>	<u>N</u>
<u>Colleges [4]</u>	<u>L</u>	<u>L</u>
<u>Community Service</u>	<u>P</u>	<u>P</u>
<u>Daycare</u>	<u>P</u>	<u>P</u>
<u>Medical Center</u>	<u>N</u>	<u>N</u>
<u>Parks and Open Areas</u>	<u>N</u>	<u>N</u>
<u>Religious Institutions</u>	<u>P</u>	<u>P</u>
<u>Schools</u>	<u>P</u>	<u>P</u>
<u>Other Categories</u>		
<u>Agriculture</u>	<u>N</u>	<u>N</u>
<u>Aviation and Surface Passenger Terminals</u>	<u>N</u>	<u>N</u>
<u>Detention Facilities</u>	<u>N</u>	<u>N</u>
<u>Essential Public Facilities</u>	<u>CU</u>	<u>CU</u>

Mining	<u>N</u>	<u>N</u>
Rail Lines and Utility Corridors	<u>N</u>	<u>N</u>
[1] Must comply with the regulations found in SMC 17C.190.100.		
[2] Residential uses are not permitted on the ground floor in Shopfront designated areas.		
[3] Structured parking is not permitted on the ground floor in Shopfront designated areas.		
[4] The accessory uses of housing, retail, and offices are permitted. Lecture halls, food halls, health and sports facilities, laboratories, and other accessory uses not specifically allowed are not permitted within the Hamilton Form-Based Code. Dormitory style housing must comply with the regulations found in SMC 17C.190.100 for group living.		

Section 5. That SMC Section 17C.123.050 is amended to read as follows:

Section 17C.123.050 ((Streetscape Requirements)) Parking and Pedestrian Connectivity

((This section identifies features and specifications for commercial and residential streets and alleys within FBC Limits, keyed to the street types identified in the Street Section Plan and to Shopfront Street areas noted on the Regulating Plan. These criteria work to establish the type of active, economically vibrant public realm sought by the community, balancing vehicular access with the safety and convenience of pedestrians and other non-motorized modes of travel.

A. Streetscape Requirements.

Required streetscape features and dimensions of those elements are identified in Table 17C.123.050-1.))

((Table 17C.123.050-1 Streetscape Requirements [1]					
	Type 1	Type 2	Type 3	Type 4	Alley
Sidewalks					
Overall Width (each side)	12' to 22'	12'	12'	12'	N/A
Type	A	A	A	A	N/A
Clear Pedestrian Zone	7'	7'	7'	7'	N/A
Planting Zone (each side) [2]	5'	5'	5'	5'	N/A
Street Furnishings					
Lighting, types	P [3]	P[3]	P[3]	P[3]	∅
Planting, types	S	S/M	S/M	S	N/A
Benches	R	R	R	N/R	N/A
Trash receptacles	R	R	R	N/R	N/A
Bicycle parking	N/R	N/R	N/R	N/R	N/A

[1] See City of Spokane Department of Engineering Design Standards for additional specifications.

[2] Minimum size; Existing tree lawn widths vary on Type 2, 3 and 4 Streets. Additional setbacks, if any, should match existing tree lawn widths in the CA-4 zone. Please see 17C.200 for additional street tree requirements.

[3] See Figure 17C.123.050-B (below) for Pedestrian Scale Lighting Standards
Parking Stall types: "A" = 8.5' W x 18' L parallel stalls; "B" = 9' W x 16' L angled stalls, back-in (60°?)

Sidewalk types: "A" = 4' x 2' scored concrete

Lighting types: "P" = Pedestrian scale; "V" = Vehicle scale

Planting types: "S" = Street trees; "M" = Median planting

Benches, Trash receptacles, Bicycle parking: "R" = Required; "N/R" = Not required))

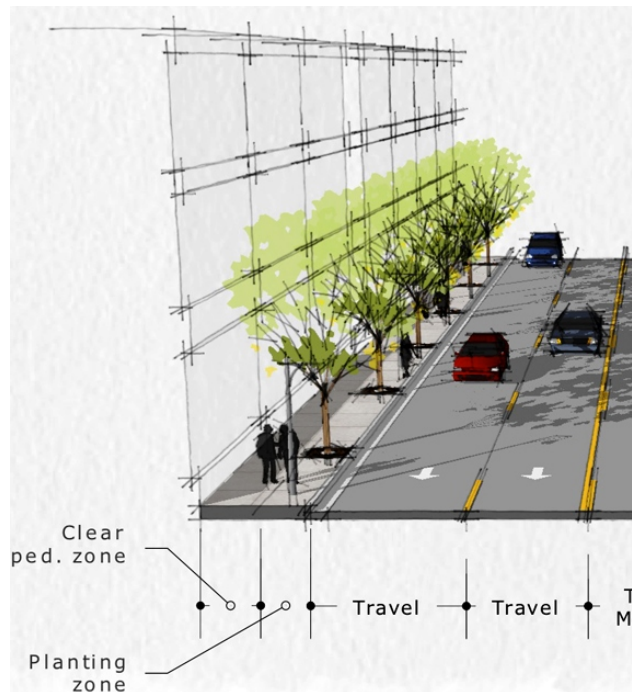

((Figure 17C.123.050-A—Desired Frontage Characteristics.))

[NOTE: Delete graphic above]

((A.—Sidewalks.

The composition and color of sidewalks shall be as described in Table 17C.123.050-1, and shall be continued as they cross vehicular driveways (See Figure 17C.123.050-E).

1. ~~When the existing sidewalk width is less than 12 feet structures shall be allowed no closer than 12 feet from the back of the curb.~~
2. ~~When the existing sidewalk width is greater than the bare minimum of 12 feet the sidewalk environment shall be designed to meet the intent of the Street Type designation of the street. Existing sidewalk width shall not be reduced or encroached upon by new development.~~

B. ~~Street Furnishings, Placement.~~

~~Street furnishings including light poles, benches, and trash receptacles shall be placed between tree locations within the Planting Zone. Street furnishings shall not impede the clear view triangle. Temporary and intermittent sidewalk encroachments including café seating, planters, ramps, steps, and sandwich board signs may be located in the Planting Zone without restriction, or in the Clear Pedestrian Zone provided a pathway of at least six (6) feet wide remains free of such obstructions (See Figure 17C.123.050-F). Bicycle parking is encouraged where the requirement for the Planting Zone and Clear Pedestrian Zone can be met. Bicycle parking provided in the streetscape can contribute to requirements in SMC 17C.230.200(1)(b). Street furnishings required in Table 17C.123.050-1 are to be provided in all Context Areas as follows:~~

1. ~~Planting— Street trees must be installed and maintained by the adjacent property in all streets bordering development. Generally, street trees should be spaced on average 25 feet apart. At a minimum, street trees shall provide a continuous row of City-approved trees spaced according to mature canopy size, plus one or more types of City-approved ground cover. Additional requirements for landscaping are stated in chapter 17C.200, Landscaping and Screening.~~
2. ~~Lighting – City-approved Traditional Series pedestrian scale lighting as shown in Figure 17C.123.050-B (flower basket optional) shall be provided and spaced at an average 50 to 60 feet apart, generally midway between required street trees and centered thirty-six (36”) from the curb to ensure a uniform distance from the street edge along the entire street.~~
3. ~~City approved benches and trash receptacles shall be provided for all buildings larger than 10,000 sf. Buildings less than this size are encouraged to include such amenities.))~~

Hamilton FBC Pedestrian Light Standards

C.1. The City of Spokane Traditional Series pedestrian acorn light (flower basket optional) shall be installed at an average 25' spacing generally spaced midway between street trees and centered thirty-six inches (36") from the curb to ensure a uniform distance from street edge along the entire street.

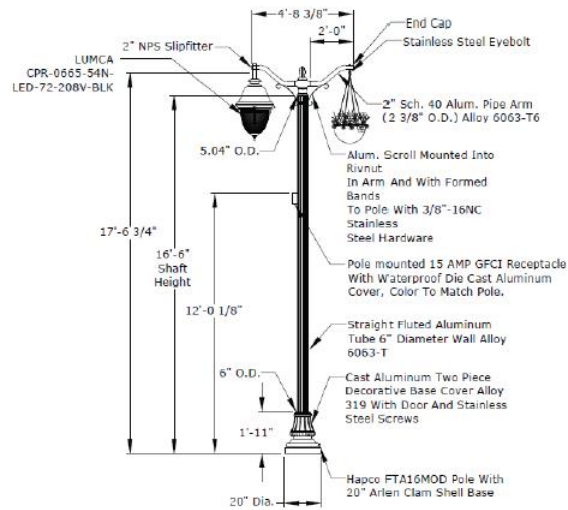

Traditional Series Light Fixture
Not to Scale

((Figure 17C.123.050-B))

[NOTE: Delete graphic above]



((Figure 17C.123.050-E: Curb cuts and driveways may not interrupt sidewalk material and pattern requirements. Ramps may not encroach on Clear Pedestrian Zones.))

[NOTE: Delete graphic above]



((Figure 17C.123.050-F: Temporary sidewalk encroachments are allowed in the Planting Zone, or in the Clear Pedestrian Zone as per Table 17C.123.050-4.))

[NOTE: Delete graphic above]

The Hamilton Form-Based Code (FBC) establishes parking standards that support pedestrian and vehicular movement within and through the area to provide a safe and convenient environment for transit, walking, biking, and rolling.

A. Dimensional standards and other off-street parking requirements are found in SMC 17C.230.200 unless otherwise modified in this chapter.

B. Minimum Parking.

For all uses within the Hamilton FBC area, there are no minimum vehicular off-street parking spaces.

C. Maximum Parking.

A maximum of 2 spaces for every 500 square feet of floor area is permitted.

D. Parking Location.

1. Off-Street Surface Parking.

a. Off-street surface parking shall not be placed between the street right-of-way and the building fronting the street.

2. Shopfront Designated Areas.

If fronting on a Shopfront designation, above-ground parking structures shall provide continuous ground level commercial or office spaces and uses along the street, except at ingress and egress points into the structure. (See Figure 17C.123.040-A).

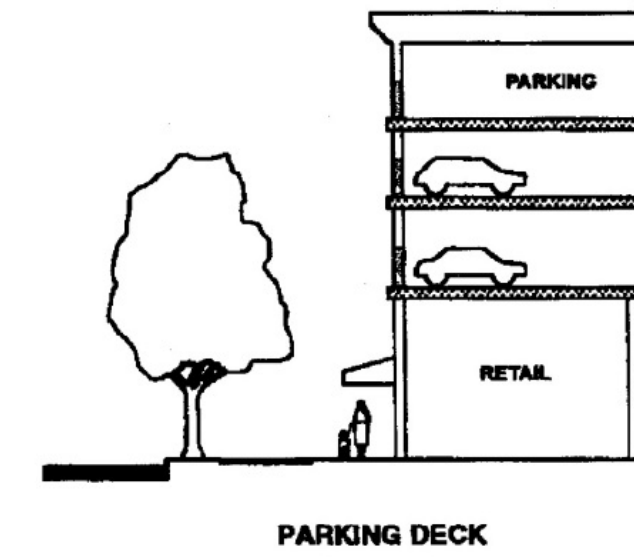

Figure 17C.123.40-A

3. Bicycle Parking.

Requirements for bicycle parking are found in SMC 17C.230.200. Bicycle parking provided in the streetscape can contribute to requirements in SMC 17C.230.200.

4. Site Lighting.

Surface parking lot and site lighting shall contribute to the visibility and safety of the site and adjacent rights-of-way, while not disturbing adjacent properties. Surface lot and site lighting shall adhere to the following standards:

a. Lighting types.

Pedestrian-scale fixtures shall be used for all lighting illuminating required Pedestrian Paths. Vehicle-scale fixtures may be used for general surface lot and site lighting. Lighting shall meet the dimensions of Figure 17C.123.40-B.

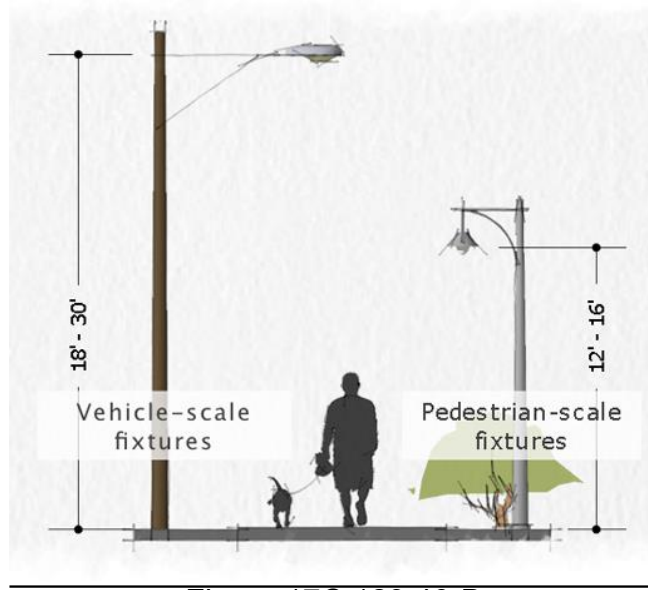

Figure 17C.123.40-B

b. Performance.

Parking lot and site lighting shall provide adequate night visibility and security by distributing a minimum of two foot-candles to a maximum of six foot-candles of illumination at ground level. All lighting shall be shielded from producing off-site glare, directing light downward and away from adjacent properties.

5. Driveways/Site Access.

Driveway widths shall not exceed 24 feet, and curb cuts shall not exceed 30 feet for combined entry/exits.

6. Pedestrian Walkways.

a. Within surface lots containing more than 30 parking stalls, pedestrian-friendly walkways shall be provided between the surface lots and building entrances.

b. Pedestrian Paths shall be not less than five feet wide and be clearly defined, using at least two of the following:

i. Six-inch vertical curbing

ii. Textured paving, including across vehicle lanes

iii. Continuous landscaped area at a minimum of 3 feet wide on at least one side of the walkway.

Section 6. That SMC Section 17C.123.060 is amended to read as follows:

Section 17C.123.060 ((Architectural Requirements)) Streetscape Requirements

~~((This section identifies general architectural requirements and guidelines, articulating basic façade requirements, roofline objectives, mechanical screening and other considerations. These requirements and guidelines establish important functional and aesthetic characteristics sought by the community and expressed by the Regulating Plan, ensuring the proper “fit” within the surrounding neighborhood.~~

A. Building Base.

~~For CA-1, CA2, CA3 and all Shopfront Street areas, building façades shall include a visually prominent plinth or base, helping establish pedestrian-scaled features and aesthetically tying the building to the street level. Building bases shall measure between 9” and 16” above adjacent grade, and utilize at least one of the following:~~

- ~~1. “Heavier” material composition, such as a stronger, more permanent material than used on upper portions of the façade.~~
- ~~2. A horizontal projection showing visible thickening of the wall surface that may be accompanied by a change of material and/or color.~~
- ~~3. A horizontal architectural line or feature, such as a belt course or secondary cornice, at or below the top of the first story and providing visual separation between the first two floors (See Figure 17C.123.060-A).~~

B. Primary Building Entries.

~~For CA-1, CA2, CA3 and all Shopfront Street areas, Primary Building Entries shall face the street and be made visually prominent, including the use of a recommended accent material and at least one of the following:~~

- ~~1. Recessed entrance. Recessed entrance shall be recessed at least 3’ from the building face.~~
- ~~2. Canopy or awning. Canopy or awning shall extend at least 5’ from the building face, with a minimum height clearance of 8’ above the sidewalk.~~
- ~~3. Inclusion of a volume that protrudes from the rest of building surface or an Architectural Roof Structure element physically or visually integrated with the Primary Building Entry (See Figure 17C.123.060-B).~~
- ~~4. For mixed-use buildings, entrances to residential, office or other upper story uses shall be clearly distinguishable in form and location from retail entrances.))~~



((Figure 17C.123.060-A: Illustration of building base, pedestrian scale-signs and other building elements described in the FBC.))

[NOTE: Delete graphic above]



((Figure 17C.123.060-B: Primary Building Entrances must face the street and be made visually prominent using one or more architectural approaches listed in 17C.123.070-B.))

[NOTE: Delete graphic above]

~~C. Street-level Detailing.~~

~~For CA-1, CA2, CA3 and all Shopfront Street areas, street-level façades shall help create a more welcoming, aesthetically rich pedestrian environment by incorporating at least four of the following elements:~~

- ~~1. Canopies or awnings spanning at least 25% of the building façade. Canopy or awning shall extend at least 5' from the building face and shall not be closer than 2' from the curb, with a minimum height clearance of 8' above the sidewalk.~~
- ~~2. Pedestrian-Scaled Signs, mounted to the building or permanent overhang.~~
- ~~3. Decorative sconce, lantern or similar lighting, mounted to the building.~~
- ~~4. Projecting windowsills.~~
- ~~5. Decorative kick plates for entry doors.~~
- ~~6. Hanging planters supported by brackets mounted to the building.~~

~~D. Façade Transparency.~~

Building façades shall include substantial glazing, providing visual connectivity between activities inside and outside a building. Regarding glazing, the following provisions shall apply:

1. If fronting along a Shopfront Street, ground floor glazing shall be at least ten feet (10') in height and no more than three feet (3') above adjacent sidewalk or grade.
2. If facing a public street, upper floor façades shall include a minimum of 30% clear glass windows.
3. The total glazing expressed as a minimum percentage of ground floor façades shall meet the specifications provided in Table 17C.123.060-1.

	CA-1	CA-2	CA-3	CA4
Along Shopfront Street	60%	60%	50%	N/A
Along Non-Shopfront Street	40%	30%	30%	30%

*Glazing percentages may include windows and doors.

E. Blank Walls.

Minimizing blank or undifferentiated façade walls helps ensure that buildings contribute to an engaging pedestrian environment. In all CA areas, blank façade walls longer than 30' along any public right-of-way shall be enhanced or screened by incorporating the following:

1. Vegetation such as espalier trees and/or vines planted adjacent to the wall surfaces.
2. Architectural detailing, such as reveals, contrasting materials, bas-relief detailing, artwork, murals, or decorative trellises.
3. Roof Lines.

F. In all CA areas, roofline elements shall adhere to the following standards:

1. Pitched or sloping roofs shall have a minimum slope of 4:12 and a maximum slope of 12:12 (rise:run).
2. Buildings with flat roofs shall include an extended parapet on all building sides, creating a defined cornice or prominent top edge.
3. Non-Enclosed, Enclosed and Architectural Roof Structure elements as defined by this code in are exempt from sections 17C.123.060 F.1 and

~~17C.123.060 F.2. Height limitations for such elements are provided in 17C.123.040.~~

~~G. Equipment Screening.~~

~~In all CA zones visible from public rights-of-way, mechanical and electrical equipment including HVAC units, transformers, antennae and receiving dishes shall be screened from view, adhering to the following standards:~~

- ~~1. Rooftop mechanical and electrical equipment shall be screened by a parapet wall, enclosed within roof volumes or other building elements designed as an integral part of the building's architecture.~~
- ~~2. Ground-level mechanical and electrical equipment shall be enclosed within secondary building elements, or screened by features designed to coordinate with the architectural character of the primary structure. Picket or chain-link fencing may not be used (See Figure 17C.123.060 C).~~

~~H. Service Area Screening.~~

~~In all CA zones, service, loading and trash collection areas shall be hidden or screened from view along public rights-of-way, and shall not face any public street or residential area unless no other location is possible. Service areas shall be hidden from view using a screen wall constructed of masonry, wood or metal, designed to coordinate with the architectural character of the primary structure. Screen walls shall also include one or more of the following:~~

- ~~1. Vegetation such as espalier trees and/or vines planted adjacent to the wall surfaces.~~
- ~~2. Architectural detailing, such as reveals, contrasting materials, bas-relief detailing, artwork, murals, or decorative trellises.~~

~~I. Sign Standards.~~

~~For sign standards applying to all CA zones, see City of Spokane Municipal Code, Chapter 17C.240. For the purposes of signs standards CA1 and CA2 shall be evaluated as CC1 zone; CA3 shall be evaluated as CC2; and CA4 shall be evaluated as a residential zone.~~

~~J. Materials.~~

~~Use of quality building materials ensures that projects contribute to the overall value and character of properties within and adjacent to HFBC Limits. Buildings shall employ durable and high quality materials, such as steel, glass, brick, stone, and/or wood. (See Figure 17C.123.060 D).)~~

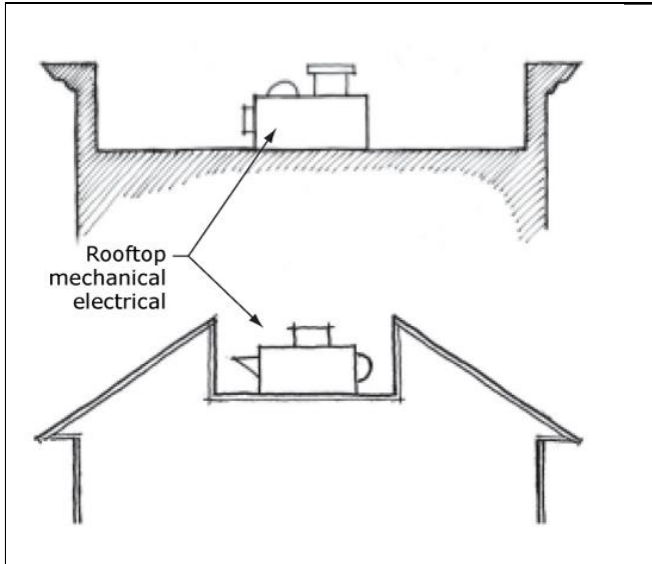

((Figure 17C.123.060-C: Rooftop and ground-level equipment must be screened from view along public rights-of-way. Here mechanical systems are hidden by cornice and roof elements.))

[NOTE: Delete graphic above]



((Figure 17C.123.060-D: The HFBC provides standards and guidelines regarding building materials, helping realize community expectations for the corridor and neighborhood.))

[NOTE: Delete graphic above]

((K.—Guidelines.

In addition to the material standards defined in this section, the following guidelines are included to further define community expectations for projects within all CA zones within Regulating Plan limits. The guidelines presented in this section are optional and intended to express desirable characteristics for the district.

1. The use of sustainably harvested, salvaged, recycled reused products is encouraged wherever possible.
2. Optional – Recommended entry treatments include special paving materials such as ceramic tile; ornamental ceiling treatments; decorative light fixtures; decorative door pulls, escutcheons, hinges, and other hardware.
3. Authentic materials and methods of construction should be used to the greatest degree possible. Materials made to simulate higher-value materials and construction types may be used for reasons of economy, but should be durable and closely match the proportions, surface finishes, and colors of the materials they simulate.

4. When veneers are used, detailing and installation should give the appearance of full-depth material, avoiding the exposure of veneer sides, including use of wrap-around corner pieces.—
5. The location and spacing of panel or expansion joints should be incorporated into the façade composition. Castings should be shaped to form architectural profiles that create bases, cornices, pilasters and other elements contributing to the façade composition.—
6. Cladding and/or accent materials on the primary building should be carried over onto additions, accessory buildings and site features.—
7. Recommended cladding materials include:
 - a. Brick. Red brick is characteristic of the Spokane region, although other colors may be used as well. Full size brick veneer is preferable to thin brick tile.
 - b. Stone. Granite, limestone, sandstone, and river rock are preferred stone types. Stone veneer and cast stone simulating these types is allowable.
 - c. Cast concrete. Precast or exposed site-cast structural concrete is acceptable. Pigments, special aggregates and surface textures should be exploited to achieve architectural effects.
 - d. Concrete block. Where used, creativity in selecting block sizes, surface textures, course patterns and colors is encouraged.
 - e. Wood. Horizontal sidings such as clapboard, tongue-in-groove, shingles or shakes, or vertical sidings such as board and batten are acceptable. Trim elements should be used for all wood siding types. Heavy timber detailing and exposed bracing may be used where appropriate to the building style.
 - f. Fiber cement or cementitious siding. Fiber cement planks, panels and shingles and are an acceptable substitute for wood siding when used in the formats described above under “Wood.”
 - g. Stucco. Stucco, cement plaster or stucco-like finishes such as EIFS may be used along ground floor portions of rear or side service and parking exposures, provided the building base treatment used along the street façade is continued. Stucco of any type should not be used along ground floor portions of street exposures.

8. Accent materials are typically used at building entrances, window and door frames, wall bases, cornices, wainscot materials and for copings, trim, and other special elements. Recommended accent materials include:
- a. Brick. Red brick is characteristic of the Spokane region, although other colors may be used as well. Full size brick veneer is preferable to thin brick tile.
 - b. Stone. Granite, limestone, sandstone, and river rock are preferred stone types. Stone veneer and cast stone simulating these types is allowable.
 - c. Cast concrete. Precast or exposed site-cast structural concrete is acceptable. Pigments, special aggregates and surface textures should be exploited to achieve architectural effects.
 - d. Concrete block. Where used, creativity in selecting block sizes, surface textures, course patterns and colors is encouraged.
 - e. Tile. Ceramic, terra cotta and cementitious tile, whether glazed or unglazed is acceptable.
 - f. Metal. Profile, corrugated and other sheet, rolled or extruded metal is acceptable. Metal accents should have trim elements to protect edges, and be of adequate thickness to resist dents and impacts. Surfaces should be treated with a high quality, fade-resistant coating system or paint such as Kynar and Tnemec. Copper, zinc and weathering steel may be left exposed.
9. Rooflines. Varied roof planes, cornice elements, overhanging eave and roof decks are encouraged, as they increase visual interest and help implement desired character objectives.
10. Recommended materials for roofs exposed and visible from public rights of way include:
- a. Metal seam roofing. Finishes should be anodized, fluoro-coated or painted. Copper, zinc and weathering steel may be left exposed.
 - b. Slate or slate-like materials.
 - c. Sheet metal shingles.
 - d. Asphalt shingles. Projects using asphalt shingles should use the highest quality commercial grade materials, and be provided with adequate trim elements.

- 11. ~~Special Paving. Cobblestones or a stamped concrete cobblestone or brick pattern are recommended for special paving and pedestrian buffer strips~~
- 12. ~~Frontage Types. Figure 17C.123.060E clarifies expectations for how buildings will meet the street.))~~

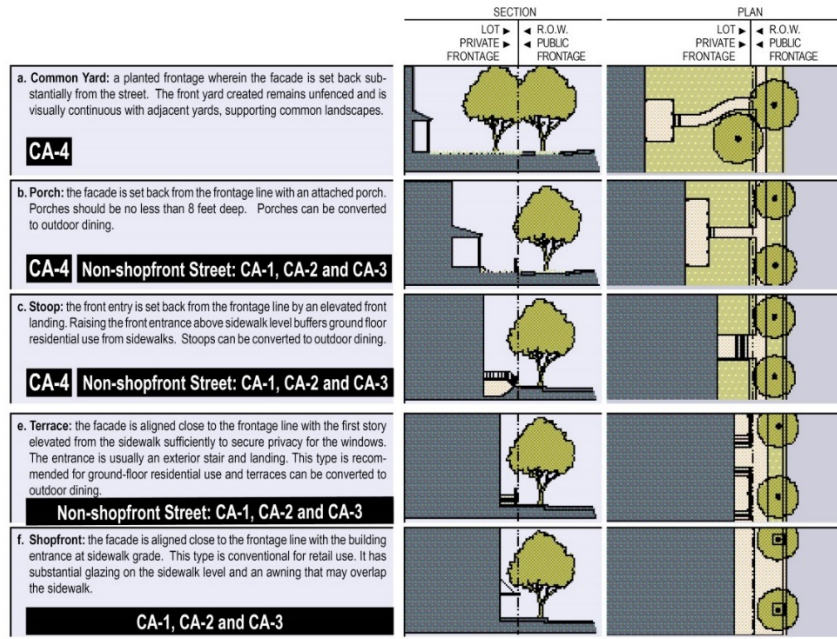

((Figure 17C.123.060 E: Frontage Types))

[NOTE: Delete graphic above]

This section of the Hamilton Form-Based Code (FBC) identifies features and specifications for area streets and alley. The standards work to establish the type of active, economically vibrant public realm sought by the area community, balancing vehicular access with the safety and convenience of transit, walking, biking, and rolling.

A. Streetscape Requirements.

Required streetscape features and dimensions of those elements are identified in Table 17C.123.050-1.

Table 17C.123.060-1 Streetscape Requirements [1]			
	CA1	Shopfront	Alley
Sidewalks			
Overall Width (each side)	12 ft.		N/A

Type	4' x 2' scored concrete		N/A
Clear Pedestrian Zone	7 ft. [2]		N/A
Buffer Zone (each side) [3]	5 ft.		N/A
Street Furnishings			
Lighting, types [4]	P	P	V
Planting, types [5]	S	S/M	N/A
Benches [6] [7]	R	R	N/A
Trash receptacles [6] [7]	R	R	N/A
Bicycle parking [6] [7]	N/R	R	N/A
[1] See City of Spokane Department of Engineering Design Standards for additional specifications.			
[2] Along Columbus Street, a 10-foot wide Clear Pedestrian Zone is required.			
[3] A reduced width may be permitted with an approved alternative planting system, such as modular suspended pavement systems, with the approval of Urban Forestry.			
[4] "P" = Pedestrian scale; "V" = Vehicle scale			
[5] "S" = Street trees; "M" = Median planting			
[6] "R" = Required; "N/R" = Not required			
[7] Buildings less than 10,000 sf. are encouraged to include such amenities but are not required.			

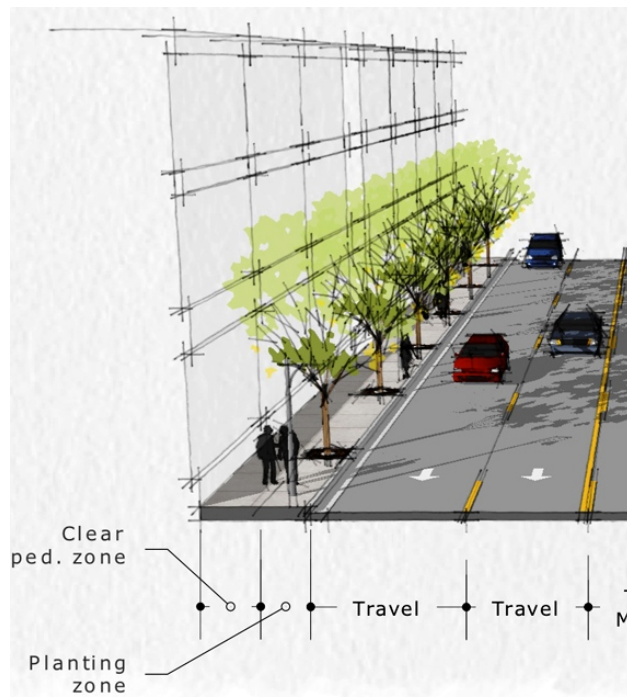

Figure 17C.123.050-A –
Desired Frontage Characteristics.

B. Sidewalks.

The composition and color of sidewalks shall be as described in Table 17C.123.050-1 and shall be continued as they cross-vehicular driveways (See Figure 17C.123.050-B).

1. When the existing sidewalk width is less than 12 feet, structures shall be allowed no closer than 12 feet from the back of the curb.
2. When the existing sidewalk width is greater than the bare minimum of 12 feet, the existing sidewalk width shall not be reduced or encroached upon by new development.

C. Street Furnishings.

Street furnishings including light poles, benches, and trash receptacles shall be placed between tree locations within the Planting Zone. Street furnishings shall not impede the clear view triangle. Street furnishings required in Table 17C.123.050-1 are to be provided as follows:

1. Planting.

Street trees must be installed and maintained by the adjacent property in all streets bordering development. Generally, street trees should be spaced on average 25 feet apart. At a minimum, street trees shall provide a continuous row of City-approved trees spaced according to mature canopy size, plus one or more types of City-approved ground cover. Additional requirements for landscaping are stated in chapter 17C.200 SMC, Landscaping and Screening.

2. Lighting.

City-approved Traditional Series pedestrian scale lighting as shown in Figure 17C.123.050-C (flower basket optional) shall be provided and spaced at an average 50 to 60 feet apart, generally midway between required street trees and centered thirty-six (36") from the curb to ensure a uniform distance from the street edge along the entire street.

Hamilton FBC Pedestrian Light Standards

C.1. The City of Spokane Traditional Series pedestrian acorn light (flower basket optional) shall be installed at an average 25' spacing generally spaced midway between street trees and centered thirty-six inches (36") from the curb to ensure a uniform distance from street edge along the entire street.

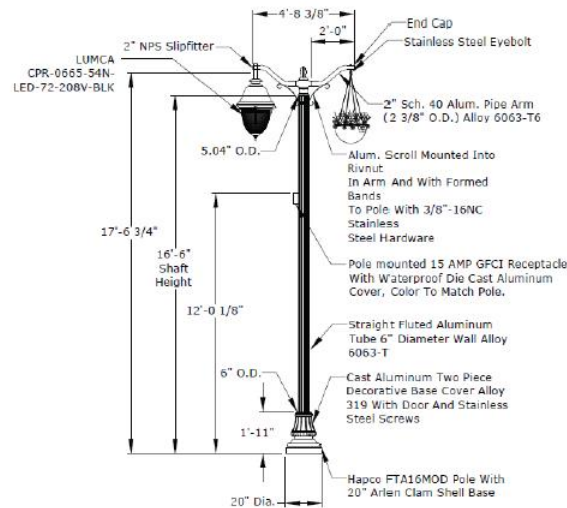

Traditional Series Light Fixture
Not to Scale

Figure 17C.123.050-C

D. Bicycle Parking.

Bicycle parking is encouraged where the requirement for the Planting Zone and Clear Pedestrian Zone can be met. Bicycle parking provided in the streetscape can contribute to requirements in SMC 17C.230.200.

E. Temporary Encroachments.

Temporary and intermittent sidewalk encroachments including café seating, planters, ramps, steps, and sandwich board signs may be located in the Planting Zone without restriction, or in the Clear Pedestrian Zone provided a pathway of at least six (6) feet wide remains free of such obstructions (See Figure 17C.123.050-D).



Figure 17C.123.050-D – Temporary sidewalk encroachments are allowed in the Planting Zone, or in the Clear Pedestrian Zone as per Table 17C.123.050-1.

F. City approved benches and trash receptacles shall be provided for all buildings larger than 10,000 sf. Buildings less than this size are encouraged to include such amenities.

Section 7. That SMC Section 17C.123.070 is amended to read as follows:

Section 17C.123.070 ((Additional Requirements)) Design Standards

~~((A.— Drive Through Facilities.~~

~~Drive-Through Facilities are prohibited in all Context Areas of the FBC.~~

~~B.— Nonconforming Situations.~~

~~Existing development that does not conform to the development standards of this chapter is subject to the standards of chapter 17C.210 SMC, Nonconforming Situations.~~

C. ~~Nuisance-related Impacts.~~

1. ~~Off-site impacts. All nonresidential uses including their accessory uses must comply with the standards of Chapter 17C.220, Off Site Impacts.~~
2. ~~Other nuisances are further regulated by state and local laws.~~

D. ~~Outdoor Activities~~

1. ~~The standards of this section are intended to assure that outdoor sales, display, storage, and work activities:~~
 - a. ~~will be consistent with the desired character of the zone;~~
 - b. ~~will not be a detriment to the overall appearance of an area;~~
 - c. ~~will not have adverse impacts on adjacent properties, especially those with residential uses; and~~
 - d. ~~will not have an adverse impact on the environment.~~
2. ~~Outdoor activities associated with permitted uses shall be permitted subject to the standards of the zone and as described below.~~
3. ~~Outdoor Sales and Display Areas.~~
 - a. ~~In the CA1—CA3 zones, outdoor sales, and display areas are limited to forty percent of lot area or one thousand five hundred square feet, whichever is less.~~
 - b. ~~Outdoor sales and display areas for uses in the industrial use categories are not allowed in the CA zones.~~
 - c. ~~In the CA 4 zone, outdoor sales and display areas are prohibited.~~
4. ~~Outdoor Storage Areas.~~
 - a. ~~Outdoor storage areas are not permitted in the CA1—CA3 zones.~~
 - b. ~~Outdoor storage areas in CA4 zones are subject to the standards of SMC 17C.110.270 Exterior Storage—Residential Zones.~~
5. ~~Outdoor Activity Area Improvements.~~

- a. ~~Outdoor activities shall be screened and landscaped according to the provisions of chapter 17C.200 SMC, Landscaping and Screening.~~
- b. ~~In order to control dust and mud, all vehicle circulation areas must be paved.~~

E. ~~Fences~~

- 1. ~~Purpose: The fence standards promote the positive benefits of fences without adversely impacting the community or endangering public or vehicle safety. Fences near streets are kept low in order to allow visibility into and out of the site and to ensure visibility for motorists. Fences in any required side or rear setback are limited in height so as to not conflict with the purpose for the setback.~~
- 2. ~~Type of Fences The standards apply to walls, fences, and screens of all types whether open, solid, wood, metal, wire, masonry, or other material.~~
- 3. ~~Location, Height, and Design.~~
 - a. ~~Street Setbacks.~~
 - i. ~~No fence or other structure is allowed within twelve feet from the back of the curb, consistent with the required sidewalk width of SMC 17C.123.060.~~
 - ii. ~~Fences up to three and one-half feet high are allowed in a required street setback that is measured from a front lot line.~~
 - iii. ~~Fences up to six feet high are allowed in required setback that is measured from a side lot line.~~
 - iv. ~~Fences shall not reduce the required setback width of SMC 17C.123.060.~~
 - v. ~~Fences up to six feet high are allowed in required side or rear setbacks except when the side or rear setback abuts a pedestrian connection. When the side or rear setback abuts a pedestrian connection, fences are limited to three and one-half feet in height.~~
 - vi. ~~The height for fences that are not in required setbacks is the same as the regular height limits of the zone.~~

b. ~~Sight-obscuring Fences and Walls.~~

- i. ~~Any required or non-required sight-obscuring fences, walls, and other structures over three and one-half feet high, and within fifteen feet of a street lot line shall either be placed on the interior side of a L2 see-through buffer landscaping area at least five feet in depth (See chapter 17C.200 SMC, Landscaping and Screening), or meet the treatment of blank walls intent outlined in SMC 17C.122.060 – Initial Design Standards and Guidelines for Center and Corridors.~~

4. ~~Prohibited Fences.~~

- a. ~~No person may erect or maintain a fence or barrier consisting of or containing barbed, razor, concertina, or similar wire except that up to three strands of barbed wire may be placed atop a lawful fence exceeding six feet in height above grade.~~
- b. ~~No person may maintain a fence or barrier charged with electricity.~~
- c. ~~A fence, wall, or other structure shall not be placed within a public right-of-way without an approved covenant as provided in SMC 17G.010.160 and any such structure is subject to the height requirement for the adjoining setback.~~
- d. ~~No permanent fence may reduce the required sidewalk width.~~

5. ~~Visibility at Intersections.~~

- a. ~~A fence, wall, hedge, or other improvement may not be erected or maintained at the corner of a lot so as to obstruct the view of travelers upon the streets~~
- b. ~~Subject to the authority of the traffic engineer to make adjustments and special requirements in particular cases, no fence exceeding a height of thirty-six inches above the curb may be inside the:~~
- i. ~~right isosceles triangle having sides of fifty feet measured along the curb line of each intersecting residential street; or~~
- ii. ~~right triangle having a fifteen-foot side measured along the curb line of the residential street and a seventy-five-foot side along the curb line of the intersecting arterial street, except that when the arterial street has a speed limit of thirty-five~~

~~miles per hour, the triangle has a side along such arterial of one hundred twenty-two feet; or~~

- ~~iii. right isosceles triangle having sides of seven feet measured along the right-of-way line of an alley and:
 - ~~1. the inside line of the sidewalk; or~~
 - ~~2. if there is no sidewalk, a line seven feet inside the curb line.~~~~

~~6. Enclosures for Pools, Hot Tubs, or Ponds.~~

- ~~a. A person maintaining a swimming pool, hot tub, pond, or other impoundment of water exceeding five thousand gallons and eighteen inches or more in depth and located on private property is required to construct and maintain an approved fence by which the pool or other water feature is enclosed and inaccessible by small children.~~
- ~~b. The required pool enclosure must be at least fifty-four inches high and may be a fence, wall, building, or other structure approved by the building services department.~~
- ~~c. If the enclosure is a woven wire fence, it is required to be built to discourage climbing.~~
- ~~d. No opening, except a door or gate may exceed four inches in any dimension.~~
- ~~e. Any door or gate in the pool enclosure, except when part of the occupied dwelling unit, must have self-closing and self-locking equipment by which the door or gate is kept secure when not in use. A latch or lock release on the outside of the door or gate must be at least fifty-four inches above the ground.~~
- ~~f. Outside of the door or gate must be at least fifty-four inches above the ground.~~

~~7. Reference to Other Standards.~~

- ~~1. Building permits are required by the building services department for all fences including the replacement of existing fences. A permit is not required to repair an existing fence.~~

~~F. Creation of new lots is subject to the standards of chapter 17G.080 SMC.)~~

All development within the Hamilton Form-Based Code (FBC) must address the following design standards, administered pursuant to SMC 17C.111.015 Design Standards Administration. When existing development is expanded, only those portions of the development that are new or renovated must meet the standards in this section.

This section also includes Guidelines that further define community desires for new development and redevelopment within the Hamilton FBC area. The Guidelines are optional and intended to express the desired built form for the area.

A. Building Base.

Building façades shall include a visually prominent plinth or base, helping establish pedestrian-scaled features and aesthetically tying the building to the street level. Building bases shall measure between 9 inches and 16 inches above adjacent grade, and utilize at least one of the following:

1. A horizontal projection of at least 3 inches that may be accompanied by a change of material and/or color.
2. A horizontal architectural line or feature, such as a belt course or secondary cornice, at or below the top of the first story and providing visual separation between the first two floors (See Figure 17C.123.060-A).

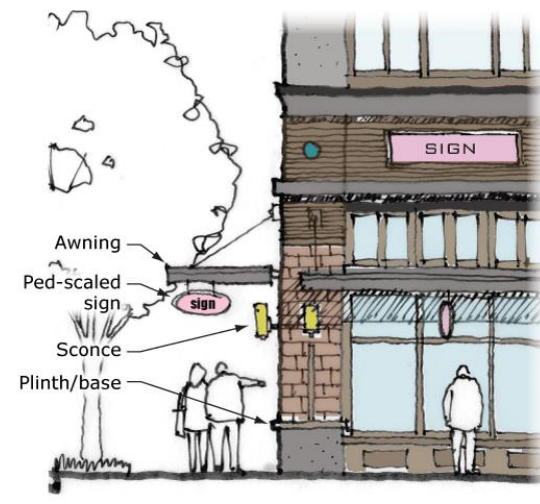

Figure 17C.123.060-A –
Illustration of building base, pedestrian scale signs and other building elements
described in the FBC.

B. Primary Building Entries.

1. Primary building entries shall face the street and be made visually prominent, including at least one of the following:
 - a. An entrance recessed at least 3' from the building face.
 - b. A canopy or awning that extends at least 5' from the building face, with a minimum height clearance of 8' above the sidewalk.
2. For mixed-use buildings, entrances to residential, office or other upper story uses shall be clearly distinguishable in form and location from retail entrances.

C. Street-level Detailing.

Street-level façades shall help create a more welcoming, aesthetically rich pedestrian environment by incorporating at least four of the following elements:

1. Canopies or awnings spanning at least 25% of the building façade.
2. Canopy or awning shall extend at least 5' from the building face and shall not be closer than 2' from the curb, with a minimum height clearance of 8' above the sidewalk.
3. Pedestrian-Scaled Signs, mounted to the building or permanent overhang.
4. Decorative sconce, lantern, or similar lighting, mounted to the building.
5. Projecting windowsills.
6. Decorative kick plates for entry doors.
7. Hanging planters supported by brackets mounted to the building.

D. Façade Transparency.

Building façades shall include substantial glazing, providing visual connectivity between activities inside and outside a building. Regarding glazing, the following provisions shall apply:

1. If within a Shopfront Designation, ground floor glazing facing a public right-of-way shall be at least ten feet (10') in height and no more than three feet (3') above adjacent sidewalk or grade.
2. The total glazing expressed as a minimum percentage of ground floor façades shall meet the specifications provided in Table 17C.123.060-1.

<u>Table 17C.123.070-1</u>		
<u>Glazing minimums, ground floor facades [1]</u>		
	<u>CA1</u>	<u>Shopfront</u>
<u>Non-Residential – within 10-ft. of the sidewalk</u>	<u>40%</u>	<u>60%</u>
<u>Non-Residential – more than 10-ft. from the sidewalk</u>	<u>15%</u>	<u>15%</u>
<u>Residential</u>	<u>15%</u>	<u>15%</u>

[1] Glazing percentages may include windows and doors.

E. Ground Floor Residential.

In addition to other standards specific to residential development found within this chapter and in order to increase the privacy of residents and provide an effective transition between the public and private realm, ground floor residential within 10-ft. of a sidewalk shall:

1. Be elevated a minimum of 30 inches from grade, with alternatives approved by the Planning Director to accommodate units meeting residential visitability standards found in SMC 17C.111.600;
2. Incorporate a patio, porch, deck, or stoop with covered entry between the entry and sidewalk; and
3. Integrate L3 Open Area Landscaping, as defined in SMC 17C.200.030 Landscape Types, between the sidewalk and building.

F. Blank Walls.

Minimizing blank or undifferentiated façade walls helps ensure that buildings contribute to an engaging pedestrian environment. Blank façade walls longer than 30' along any public right-of-way shall be enhanced or screened by incorporating the following:

1. Public art such as murals;
2. Vegetation such as espalier trees and/or vines planted adjacent to the wall surfaces;
3. Architectural detailing, such as reveals, contrasting materials, bas-relief detailing, or decorative trellises; or
4. Roof Lines.

G. Roof Lines.

1. Pitched or sloping roofs shall have a minimum slope of 4:12 and a maximum slope of 12:12 (rise:run).
2. Buildings with flat roofs shall include an extended parapet on all building sides, creating a defined cornice or prominent top edge.
3. Non-Enclosed, Enclosed, and Architectural Roof Structure elements as defined by this code are exempt from sections 17C.123.060(G)(1) and 17C.123.060(G)(2). Height limitations for such elements are provided in Table 17C.123.030-1.

H. Equipment Screening.

Mechanical and electrical equipment including HVAC units, transformers, antennae and receiving dishes visible from public rights-of-way shall be screened from view, adhering to the following standards:

1. Rooftop mechanical and electrical equipment shall be screened their full height by a parapet wall, enclosed within roof volumes or other building elements designed as an integral part of the building's architecture.
2. Ground-level mechanical and electrical equipment shall be enclosed within secondary building elements or screened by features designed to coordinate with the architecture of the primary structure. Year-round vegetative screening the height of the equipment at planting is permitted. Picket or chain-link fencing may not be used (See Figure 17C.123.060-B).

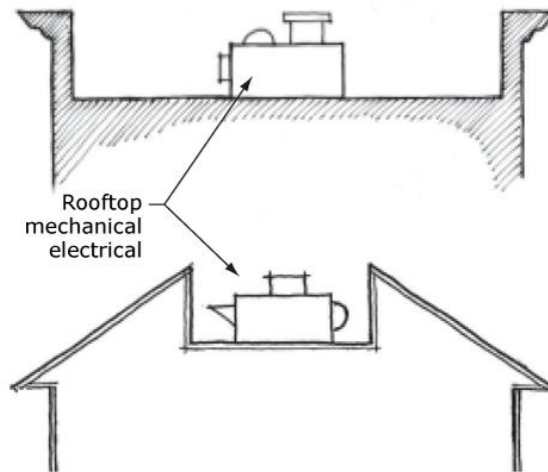

Figure 17C.123.060-B –

Rooftop and ground-level equipment must be screened from view along public rights-of-way. Here mechanical systems are hidden by cornice and roof elements.

I. Service Area Screening.

Service, loading, and trash collection areas shall be hidden or screened from view along public rights-of way and shall not face any public street or residential area unless no other location is possible. Service areas shall be hidden from view using a screen wall constructed of masonry, wood, or metal, designed to coordinate with the architecture of the primary structure. Screen walls shall also include one or more of the following:

1. Vegetation such as espalier trees and/or vines planted adjacent to the wall surfaces.
2. Architectural detailing, such as reveals, contrasting materials, bas-relief detailing, or decorative trellises.
3. Public art such as murals.

J. Sign Standards.

See City of Spokane Municipal Code, Chapter 17C.240 for sign standards. Signs within the CA zone are subject to the standards and guidelines contained in the Initial Design Standards and Guidelines for Centers and Corridors.

- K. Swimming pool, hot tub, pond, or other impoundment of water exceeding five thousand gallons and eighteen inches or more in depth must be located within a fully enclosed building.

L. Guidelines.

In addition to the material standards defined in this section, the following guidelines are included to further define community expectations for projects within the Hamilton FBC area. The guidelines presented in this section are optional and intended to express desirable characteristics for the district.

1. Sustainable Design.

- a. The use of sustainably harvested, salvaged, recycled, and reused products is encouraged wherever possible.
- b. The rehabilitation of older buildings should be considered before new construction. If removal is required, the deconstruction of existing development is encouraged.
- c. Integration of Green Stormwater Infrastructure (GSI) should be considered in conjunction with property redevelopment.
- d. Property owners are encouraged to replace or reduce ground cover like grass lawns and pavement with native and/or drought tolerant plantings.
- e. The installation and maintenance of green roofs is encouraged.

2. Trail-Oriented Development.

For properties along the Centennial Trail, development is encouraged to orient towards the trail, which can be accomplished by:

- a. Having patios and decks that overlook the trail.
- b. Having an increased level of façade transparency to increase “eyes on the trail”.
- c. Having a covered entry facing the trail.

d. Avoiding tall fences and blank walls facing the trail.

3. Building Entries.

Recommended entry treatments include special paving materials such as ceramic tile; ornamental ceiling treatments; decorative light fixtures; decorative door pulls, escutcheons, hinges, and other hardware.

4. Building Materials.

a. Authentic materials and methods of construction should be used to the greatest degree possible. Materials made to simulate higher-value materials and construction types may be used for reasons of economy, but should be durable and closely match the proportions, surface finishes, and colors of the materials they simulate.

b. When veneers are used, detailing and installation should give the appearance of full-depth material, avoiding the exposure of veneer sides, including the use of wrap-around corner pieces.

c. Cladding and/or accent materials on the primary building should be carried over onto additions, accessory buildings, and site features.

d. Recommended cladding materials include:

i. Brick. Red brick is characteristic of the Spokane region, although other colors may be used as well. Full size brick veneer is preferable to thin brick tile.

ii. Stone. Granite, limestone, sandstone, and river rock are preferred stone types. Stone veneer and cast stone simulating these types is allowable.

iii. Cast concrete. Precast or exposed site-cast structural concrete is acceptable. Pigments, special aggregates, and surface textures should be exploited to achieve architectural effects.

iv. Concrete block. Where used, creativity in selecting block sizes, surface textures, course patterns and colors is encouraged.

v. Wood. Horizontal sidings such as clapboard, tongue-in-groove, shingles or shakes, or vertical sidings such as board and batten are acceptable. Trim elements should be used for all wood siding types. Heavy timber detailing and exposed bracing may be used where appropriate to the building style.

vi. Fiber-cement or cementitious siding. Fiber-cement planks, panels and shingles and are an acceptable substitute for

wood siding when used in the formats described above under "Wood."

- vii. Stucco. Stucco, cement plaster or stucco-like finishes such as EIFS may be used along ground floor portions of rear or side service and parking exposures, provided the building base treatment used along the street façade is continued. Stucco of any type should not be used along ground floor portions of street exposures.
- e. Accent materials are typically used at building entrances, window and door frames, wall bases, cornices, wainscot materials and for copings, trim, and other special elements. Recommended accent materials include:
 - i. Brick. Red brick is characteristic of the Spokane region, although other colors may be used as well. Full size brick veneer is preferable to thin brick tile.
 - ii. Stone. Granite, limestone, sandstone, and river rock are preferred stone types. Stone veneer and cast stone simulating these types is allowable.
 - iii. Cast concrete. Precast or exposed site-cast structural concrete is acceptable. Pigments, special aggregates and surface textures should be exploited to achieve architectural effects.
 - iv. Concrete block. Where used, creativity in selecting block sizes, surface textures, course patterns and colors is encouraged.
 - v. Tile. Ceramic, terra cotta and cementitious tile, whether glazed or unglazed is acceptable.
 - vi. Metal. Profile, corrugated and other sheet, rolled or extruded metal is acceptable. Metal accents should have trim elements to protect edges, and be of adequate thickness to resist dents and impacts. Surfaces should be treated with a high quality, fade-resistant coating system or paint such as Kynar and Tnemec. Copper, zinc and weathering steel may be left exposed.
- f. The location and spacing of panel or expansion joints should be incorporated into the façade composition. Castings should be shaped to form architectural profiles that create bases, cornices, pilasters and other elements contributing to the façade composition.

5. Rooflines.

Varied roof planes, cornice elements, overhanging eave and roof decks are encouraged, as they increase visual interest and help implement desired character objectives.

a. Recommended materials for roofs exposed and visible from public rights of way include:

i. Metal seam roofing. Finishes should be anodized, fluoro-coated or painted. Copper, zinc and weathering steel may be left exposed.

ii. Slate or slate-like materials.

iii. Sheet metal shingles.

iv. Asphalt shingles. Projects using asphalt shingles should use the highest quality commercial grade materials and be provided with adequate trim elements.

6. Special Paving.

Cobblestones or a stamped concrete cobblestone or brick pattern are recommended for special paving and pedestrian buffer strips.

Section 8. That SMC Section 17C.123.080 is amended to read as follows:

Section 17C.123.080 ((Building Type Catalogs)) Additional Requirements

A. Outdoor Activities

The standards of this section are intended to assure that outdoor sales, display, storage, and work activities will not have adverse impacts on adjacent properties or the environment, while providing the envisioned built form within the area.

1. Outdoor Sales and Display Areas.

a. Outdoor sales and display areas are limited to forty percent of lot area or one thousand five hundred square feet, whichever is less, in the CA1 zone.

b. Outdoor sales and display areas for uses in the industrial use categories are not allowed in the CA1 zone.

c. In the Shopfront designations, accessory outdoor sales are permitted so long as the Clear Pedestrian Zone and Buffer Zone is maintained.

d. In the Shopfront designations, outdoor display areas are prohibited.

2. Outdoor Storage Areas.

a. Outdoor storage areas are not permitted.

3. Outdoor Activity Area Improvements.

- a. Outdoor activities shall be screened and landscaped according to the provisions of chapter 17C.200 SMC, Landscaping and Screening.
- b. In order to control dust and mud, all vehicle circulation areas must be paved.

B. Fences.

The fence standards avoid adverse impacts on the area while protecting public or vehicle safety. Fences near streets are kept low in order to allow visibility into and out of the site and to ensure visibility for motorists. Fences in any required side or rear setback are limited in height so as to not conflict with the purpose for the setback.

1. Type of Fences.

The standards apply to walls, fences, and screens of all types whether open, solid, wood, metal, wire, masonry, or other material.

2. Location, Height, and Design

a. Street Setbacks.

- i. No fence or other structure is allowed within twelve feet from the back of the curb, consistent with the required sidewalk width of SMC 17C.123.050.
- ii. Fences up to three and one-half feet high are allowed in a required street setback.
- iii. Fences up to six feet high are allowed in required side or rear setbacks except when the side or rear setback abuts a pedestrian connection. When the side or rear setback abuts a pedestrian connection, fences are limited to three and one-half feet in height.
- iv. Fences shall not reduce the required setback width of SMC 17C.123.030.

b. Sight-obscuring Fences and Walls.

- i. Any required or non-required sight-obscuring fences, walls, and other structures over three and one-half feet high, and within fifteen feet of a street lot line shall either be placed on the interior side of a L2 see-through buffer landscaping area at least five feet in depth (See chapter 17C.200 SMC, Landscaping and Screening), or meet the treatment of blank

walls intent outlined in SMC 17C.122.060 – Initial Design Standards and Guidelines for Center and Corridors.

c. Fencing Material.

- i. Fence materials within the public right-of-way or within eight feet of a street lot line should be wrought iron or similar in appearance, aluminum, metal, or similar material.
- ii. Walls visible from streets shall be masonry, stone, brick, or similar construction.
- iii. Chain link fencing is not allowed that is visible from and/or adjacent to a public street.

3. Prohibited Fences.

- a. No person may erect or maintain a fence or barrier consisting of or containing barbed, razor, concertina, or similar wire.
- b. No person may maintain a fence or barrier charged with electricity.
- c. A fence, wall, or other structure shall not be placed within a public right-of-way without an approved covenant as provided in SMC 17G.010.160 and any such structure is subject to the height requirement for the adjoining setback.
- d. No permanent fence may reduce the required sidewalk width.

4. Visibility at Intersections.

A fence, wall, hedge, or other improvement may not be erected or maintained at the corner of a lot so as to obstruct the view of travelers upon the streets.

- 6. Subject to the authority of the traffic engineer to make adjustments and special requirements in particular cases, no fence exceeding a height of thirty-six inches above the curb may be located within the Clear View Triangle, as defined in Section 17A.020.030 “C” Definitions.

Context Area 1 (CA-1)

Hamilton FBC Building Character Visual Catalog

This visual catalog showcases the type, form, and general character of desired development within Context Area 1. Images are representational only.



CA-1 Non-Shopfront

See also CA-2, CA-3 and CA-4 Non-Shopfront.



CA-1 Corner

See also CA-2 and CA-3 Corner.



CA-1 Shopfront

See also CA-2 and CA-3 Shopfront.



CA-1 - 1 to 5 Story Buildings

[NOTE: Delete graphic above]

Context Area 2 (CA-2)

Hamilton FBC Building Character Visual Catalog

This visual catalog showcases the type, form, and general character of desired development within Context Area 2. Images are representational only.



CA-2 Non-Shopfront

See also CA-3 and CA-4 Non-Shopfront.



CA-2 Corner

See also CA-3 Corner.

CA-2 Shopfront

See also CA-3 Shopfront.



CA-2 - 1 to 4 Story Buildings

[NOTE: Delete graphic above]

Context Area 3 (CA-3)

Hamilton FBC Building Character Visual Catalog

This visual catalog showcases the type, form, and general character of desired development within Context Area 3. Images are representational only.



CA-3 Non-Shopfront

See also CA-4.



CA-3 Corner



CA-3 Shopfront



CA-3 - 1 to 2 Story Buildings

[NOTE: Delete graphic above]

Context Area 4 (CA-4)

Hamilton FBC Building Character Visual Catalog

This visual catalog showcases the type, form, and general character of desired development within Context Area 4. Images are representational only.



CA-4 Small Footprint



CA-4 Medium Footprint



[NOTE: Delete graphic above]

Context Area 4 (CA-4)

Hamilton FBC Building Character Visual Catalog

This visual catalog showcases the type, form, and general character of desired development within Context Area 4. Images are representational only.



CA-4 Large Footprint



Image borrowed from daybreakutah.com



Image borrowed from daybreakutah.com

[NOTE: Delete graphic above]

PASSED by the City Council on _____.

Council President

Attest:

Approved as to form:

City Clerk

Assistant City Attorney

Mayor

Date

Effective Date

**CITY OF SPOKANE PLAN COMMISSION
FINDINGS OF FACT, CONCLUSIONS, AND RECOMMENDATIONS
REGARDING HAMILTON FORM-BASED CODE AMENDMENTS**

A recommendation of the City of Spokane Plan Commission to the City Council to approve amendments to the Spokane Municipal Code proposed Hamilton Form-Based Code update text amendments. The proposal amends the Unified Development Code (UDC) Chapter 17C.123 to implement the adopted South Logan Transit-Oriented Development Plan.

FINDINGS OF FACT:

- A. The City of Spokane adopted a Comprehensive Plan in May of 2001 that complies with the requirements of the Growth Management Act (GMA) as set forth in RCW 36.70A.
- B. In 2021, the Washington State Legislature appropriated \$2.5 million for cities to facilitate transit-oriented development planning in areas with light rail or fixed rail systems, bus rapid transit, high frequency bus service or park and ride lots.
- C. The City of Spokane prepared the Transit-Oriented Development (TOD) Framework Action Plan, adopted by resolution in May 2022 under RES 2022-0039, that identifies strategies best suited to Spokane for supporting TOD along new High-Performance Transit lines, including a focus on South Logan.
- D. The City provided opportunities for meaningful public involvement and review in the South Logan TOD Plan and EIS process, including a community meeting consistent with RCW 43.21C.440; has considered all comments received; and, as appropriate, has modified the proposal or mitigation measures in response to comments, resulting in the Preferred Alternative analyzed in the Final Environmental Impact Statement (FEIS).
- E. The *Final South Logan TOD Plan* and *Final Environmental Impact Statement (FEIS)* were published on November 30, 2023 for final consideration.
- F. On January 29, 2024 Spokane City Council adopted by resolution (RES 2024-0015) the Final South Logan TOD Plan and FEIS as a declaration of the subarea's desired future condition.
- G. In order to facilitate the higher intensity residential development envisioned in the Plan, the adopted Final South Logan TOD Plan called for strategic adjustments to the Hamilton Form-Based Code to enhance transit-oriented development opportunities, while retaining design measures to ensure that development is pedestrian-oriented and contributes to the neighborhood.
- H. The draft amendments relied on the 20-month planning process and extensive public engagement that occurred as part of the development of the South Logan TOD Plan. Outreach and public communication specifically about South Logan TOD Implementation began in February 2024 and included the following among others:
 - 1. Logan Neighborhood Council meeting presentation on February 13, 2024;

Findings of Fact, Conclusion, and Recommendation

2. Plan Commission Workshops on March 13, April 10, April 24, May 8, May 22, and June 12, 2024;
 3. Various community tabling events on March 19, April 9, and May 18, 2024;
 4. A virtual information session on April 30, 2024;
 5. Coffee Chat pop-up events on May 4, May 23, and June 1, 2024;
 6. Regular South Logan TOD newsletter and webpage updates, as well as City of Spokane newsletter and social media posts.
- I. Public comment, as well as agency and department comments, received prior to the June 26, 2024, Plan Commission public hearing were included in the staff report.
 - J. On March 13, April 10, April 24, May 8, May 22, and June 12, 2024, the Spokane Plan Commission held workshops to discuss draft language, receive updates on public feedback as well as city department and agency comments, and review and evaluate with city staff alternatives to proposed text changes.
 - K. On April 29, 2024, the Washington State Department of Commerce and appropriate state agencies were given the required 60-day notice of the City's intent to adopt updated development regulations pursuant to RCW 36.70A.106.
 - L. On April 29, 2024, a Notice of Intent to Adopt and Request for SEPA agency comments was issued for the draft code pertaining to the proposed South Logan TOD Implementation text amendments. The comment period ended on May 13, 2024. No comments were received.
 - M. The SEPA Determination of Nonsignificance and Checklist were issued by Planning Services on June 12, 2024. The comment period ended on June 26, 2024. No comments were received.
 - N. Prior to the Plan Commission public hearing, a legal notice was published in the *Spokesman-Review* on June 12 and June 19, 2024; and
 - O. The proposed text amendments were drafted and reviewed pursuant to the process established under RCW 36.70A.370 to ensure that the proposed changes will not result in unconstitutional takings of private property.
 - P. Amendments to Title 17 are subject to review and recommendation by the Plan Commission.

Findings of Fact, Conclusion, and Recommendation

- Q. On June 26, 2024, the Spokane Plan Commission held a public hearing on the proposed text amendments, including the taking of verbal testimony, and closed the public record on that date.
- R. Public comment, as well as agency and department comments, received prior to the June 26, 2024 Plan Commission public hearing were included in the staff report.
- S. During deliberations held on June 26, 2024, the Plan Commission discussed the concerns expressed in public comments and testimony about public safety within the South Logan Subarea.
- T. Except as otherwise indicated in the above findings, the Spokane Plan Commission adopts the findings and analysis set forth in the staff report prepared for the proposal.
- U. The Spokane Plan Commission finds that the proposed text amendments meet the decision criteria established in SMC 17G.025.010(G).

CONCLUSIONS:

Based upon the draft text amendments, staff report and analysis (which is hereby incorporated into these findings, conclusions, and recommendations), SEPA review, agency and public comments received, and public testimony presented, the Spokane Plan Commission makes the following conclusions with respect to the text amendments to the Hamilton Form-Based Code:

1. The Plan Commission finds that the proposed amendments bear a substantial relation to the public health, safety, welfare, and protection of the environment pursuant to the requirements outlined in SMC 17G.025.010(G).
2. The proposed text amendments will implement the goals and policies of the Comprehensive Plan.
3. The proposed text amendments will implement the adopted South Logan Transit-Oriented Development Plan.
4. Interested agencies and the public have had extensive opportunities to participate throughout the process and persons desiring to comment were given an opportunity to comment.
5. SEPA review was completed for the proposal, and pursuant to SEPA, any adverse environmental impacts associated with the proposed regulations will be mitigated by enforcement of the City's development regulations.
6. Plan Commission concludes that the intent of the including neighborhood councils to the list of entities that receive notice of applications was to give neighborhood councils standing and the ability to advocate for their neighborhood residents. As entities of standing, neighborhood councils should assume the responsibility of proactively communicated with their residents about pertinent all-city or neighborhood-specific development applications.

7. The Plan Commission finds that the proposed amendments are consistent with the applicable provisions of the Comprehensive Plan, particularly the following adopted goals and policies:
 - a. Chapter 3: Land Use – Goal 1 – Citywide Land Use, Policy LU 1.4 Higher Intensity Residential Areas
 - b. Chapter 3: Land Use – Goal 3 – Efficient Land Use, Policy LU 3.1 Coordinated and Efficient Land Use
 - c. Chapter 3: Land Use – Goal 3 – Efficient Land Use, Policy LU 3.2 Centers and Corridors
 - d. Chapter 3: Land Use – Goal 3 – Efficient Land Use, Policy 3.5 Mix of Uses in Centers
 - e. Chapter 3: Land Use – Goal 4 – Transportation, Policy LU 4.1 Land Use and Transportation
 - f. Chapter 3: Land Use – Goal 4 – Transportation, Policy LU 4.6 Transit-Supported Development
 - g. Chapter 3: Land Use – Goal 5 – Development Character, Policy LU 5.1 Built and Natural Environment
 - h. Chapter 3: Land Use – Goal 5 – Development Character, Policy LU 5.5 Complementary Development
 - i. Chapter 6: Housing – Goal H1 – Housing Choice and Diversity, Policy H 1.4 Use of Existing Infrastructure
 - j. Chapter 6: Housing – Goal H1 – Housing Choice and Diversity, Policy H 1.7 Socioeconomic Integration
 - k. Chapter 6: Housing – Goal H1 – Housing Choice and Diversity, Policy H 1.11 Access to Transportation
 - l. Chapter 8: Urban Design and Historic Presentation – Goal DP 1 – Price and Identity, Policy DP 1.2 New Development in Established Neighborhoods
 - m. Chapter 8: Urban Design and Historic Preservation – Goal DP 2 – Urban Design, Policy DP 2.2 Design Guidelines and Regulations
 - n. Chapter 8: Urban Design and Historic Preservation – Goal DP 2 – Urban Design, Policy DP 2.6 Building and Site Design
 - o. Chapter 8: Urban Design and Historic Preservation – Goal DP 2 – Urban Design, Policy DP 2.7 Historic District and Sub-Area Design Guidelines
 - p. Chapter 8: Urban Design and Historic Preservation – Goal DP 2 – Urban Design, Policy DP 2.12 Infill Development
 - q. Chapter 8: Urban Design and Historic Preservation – Goal DP 2 – Urban Design, Policy 2.13 Parking Facilities Design

- r. Chapter 11: Neighborhoods – Goal N 4 – Traffic Circulation, Policy N 4.7 Pedestrian Design
- 8. The Plan Commission recognizes the concerns expressed by community members about public safety within the South Logan Subarea. While the Plan Commission urges continued community collaboration with public safety and code enforcement officials, the body recognizes the positive impact that transit-oriented and pedestrian-oriented development can have on public safety within the built environment. Increased density and mix of uses made possible with amendments to the Center and Corridor zones, higher intensity residential zones, and height allowances, as well as street activation as called for in the Hamilton Form-Based Code, encourage more eyes on the street and have been found to have a positive effect on safety and walkability.

RECOMMENDATION:

In the matter of the ordinance pertaining to the Hamilton Form-Based Code, amending the Unified Development Code of the City of Spokane:

- 1. By a vote of seven to zero, the City of Spokane Plan Commission recommends to the Spokane City Council the **APPROVAL** of the proposed amendments to Chapter 17C.123.
- 2. The City of Spokane Plan Commission authorizes the Plan Commission President to prepare and sign on the Commission’s behalf a written decision setting forth the Plan Commission’s findings, conclusions, and recommendations on the proposed amendments.

Greg Francis
Greg Francis (Jun 27, 2024 17:43 PDT)

Greg Francis, President
Spokane Plan Commission
Jun 27, 2024 enter a date.

PC Findings and Conclusions_ Hamilton Form-Based Code

Final Audit Report

2024-06-28

Created:	2024-06-27
By:	AMANDA KIEHN (AKIEHN@SPOKANECITY.ORG)
Status:	Signed
Transaction ID:	CBJCHBCAABAAmo6jIkSQyIP0LGhBy3RjSh7xjjwyzyn6

"PC Findings and Conclusions_ Hamilton Form-Based Code" History

 Document created by AMANDA KIEHN (AKIEHN@SPOKANECITY.ORG)

2024-06-27 - 10:04:21 PM GMT

 Document emailed to gfrancis@spokanecity.org for signature

2024-06-27 - 10:04:48 PM GMT

 Email viewed by gfrancis@spokanecity.org

2024-06-28 - 0:43:09 AM GMT

 Signer gfrancis@spokanecity.org entered name at signing as Greg Francis

2024-06-28 - 0:43:33 AM GMT

 Document e-signed by Greg Francis (gfrancis@spokanecity.org)

Signature Date: 2024-06-28 - 0:43:35 AM GMT - Time Source: server

 Agreement completed.

2024-06-28 - 0:43:35 AM GMT



Agenda Sheet for City Council:

Committee: Urban Experience **Date:** 07/08/2024

Committee Agenda type: Discussion

Date Rec'd

7/8/2024

Clerk's File #

ORD C36554

Cross Ref #

Project #

Council Meeting Date: 07/22/2024

Submitting Dept

PLANNING & ECONOMIC

Bid #

Contact Name/Phone

KAYCEE X6194

Requisition #

Contact E-Mail

KDOWNEY@SPOKANECITY.ORG

Agenda Item Type

First Reading Ordinance

Council Sponsor(s)

ZZAPPONE KKLITZKE JBINGLE

Agenda Item Name

0650 - PLANNED ACTION ORDINANCE ASSOCIATED WITH S. LOGAN TOD

Agenda Wording

Adoption of the South Logan TOD Planned Action Ordinance as Chapter 17C.420 to streamline development within the South Logan Subarea.

Summary (Background)

The South Logan Transit-Oriented Development (TOD) Plan, adopted by resolution on January 29, 2024, provides recommendations to support more connectivity and livability for the community, businesses, and organization in South Logan. The proposed South Logan TOD Planned Action will adopt Chapter 17C.420 to the SMC, which aligns with the goals and recommendations of the South Logan TOD Plan and the City of Spokane Comprehensive Plan. Projects that meet the threshold criteria found within the

Lease? NO Grant related? NO Public Works? NO

Fiscal Impact

Approved in Current Year Budget? N/A

Total Cost \$

Current Year Cost \$

Subsequent Year(s) Cost \$

Narrative

The S. Logan TOD Plan and FEIS, adopted by resolution on January 29, 2024, was funded through the TOD Implementation grant program via the WA Department of Commerce. Implementation of the South Logan TOD Plan relied on on-going and regular staff resources

Amount

Budget Account

Neutral	\$	#
Select	\$	#
Select	\$	#
Select	\$	#
Select	\$	#
Select	\$	#



Continuation of Wording, Summary, Approvals, and Distribution

Agenda Wording

Summary (Background)

Planned Action Ordinance and comply with any required mitigation as identified in the South Logan Final Environmental Impact Statement are exempt from additional State Environmental Policy Act (SEPA) application and review. For the full code amendments please visit:

<https://my.spokanecity.org/projects/south-logan-transit-oriented-development-project/>

Approvals

<u>Dept Head</u>	GARDNER, SPENCER
<u>Division Director</u>	MACDONALD, STEVEN
<u>Accounting Manager</u>	ALBIN-MOORE, ANGELA
<u>Legal</u>	RICHMAN, JAMES
<u>For the Mayor</u>	JONES, GARRETT

Additional Approvals

Distribution List

smacdonald@spokanecity.org	kdowney@spokanecity.org
sgardner@spokanecity.org	tblack@spokanecity.org
tkimbrell@spokanecity.org	amccall@spokanecity.org

Committee Agenda Sheet

Urban Experience Committee

Committee Date	July 8, 2024
Submitting Department	Planning & Economic Development
Contact Name	KayCee Downey
Contact Email & Phone	kdowney@spokanecity.org , x6194
Council Sponsor(s)	<u>CM Zappone, CM Klitzke and CM Bingle</u>
Select Agenda Item Type	<input type="checkbox"/> Consent <input checked="" type="checkbox"/> Discussion Time Requested: 5 minutes
Agenda Item Name	Planned Action Ordinance Associated with South Logan TOD Implementation
Proposed Council Action	<input checked="" type="checkbox"/> Approval to proceed to Legislative Agenda <input type="checkbox"/> Information Only
Summary (Background) *use the Fiscal Impact box below for relevant financial information	<p>The South Logan Transit-Oriented Development (TOD) Plan, adopted by resolution on January 29, 2024, provides recommendations to support more connectivity and livability for the community, businesses, and organization in South Logan.</p> <p>The proposed South Logan TOD Planned Action will adopt Chapter 17C.420 to the SMC, which aligns with the goals and recommendations of the South Logan TOD Plan and the City of Spokane Comprehensive Plan.</p> <p>Projects that meet the threshold criteria found within the Planned Action Ordinance and comply with any required mitigation as identified in the South Logan Final Environmental Impact Statement are exempt from additional State Environmental Policy Act (SEPA) application and review.</p> <p>For the full code amendments please visit: https://my.spokanecity.org/projects/south-logan-transit-oriented-development-project/</p>
Fiscal Impact	
Approved in current year budget? <input type="checkbox"/> Yes <input type="checkbox"/> No <input checked="" type="checkbox"/> N/A	
Total Cost: Click or tap here to enter text.	
Narrative: The South Logan TOD Plan and FEIS, adopted by resolution on January 29, 2024, was funded through the Transit-Oriented Development Implementation (TODI) grant program through the WA Department of Commerce. Implementation of the South Logan TOD Plan relied on on-going and regular staff resources.	
Funding Source <input type="checkbox"/> One-time <input type="checkbox"/> Recurring <input checked="" type="checkbox"/> N/A	
Specify funding source: Select Funding Source*	
Is this funding source sustainable for future years, months, etc? Click or tap here to enter text.	
Expense Occurrence <input type="checkbox"/> One-time <input type="checkbox"/> Recurring <input checked="" type="checkbox"/> N/A	
Other budget impacts: (revenue generating, match requirements, etc.)	
Operations Impacts (If N/A, please give a brief description as to why)	
<i>What impacts would the proposal have on historically excluded communities?</i>	
The proposed text amendments are intended to support high quality transit, increase housing capacity and diversity, and promote affordability along the City Line bus rapid transit in the South Logan area and throughout	

Center and Corridor and higher intensity residential areas throughout Spokane. By focusing on development along transit lines and removing identified barriers to successful projects, the proposals are intended to support a diversity of uses and housing options near existing multimodal transportation options.

How will data be collected, analyzed, and reported concerning the effect of the program/policy by racial, ethnic, gender identity, national origin, income level, disability, sexual orientation, or other existing disparities?

The South Logan TOD Plan reviewed and analyzed environmental and social impacts of planned development and development alternatives as part of the process, following the guidance of the HEAL Act. An analysis of existing conditions established a baseline to inform the project with data on demographics, socioeconomics, housing and market conditions, land use and zoning, and infrastructure needs. The proposals are implementing the adopted Plan with no additional data collection.

How will data be collected regarding the effectiveness of this program, policy, or product to ensure it is the right solution?

The South Logan TOD Plan was developed after a 20-month community engagement process that sought input from residents, businesses, institutions, agency partners, and other subject matter experts. The proposals are implementing the recommendations of the adopted Plan. Additional community outreach and engagement occurred after draft ordinances were available to verify effectiveness of the implementation.

Describe how this proposal aligns with current City Policies, including the Comprehensive Plan, Sustainability Action Plan, Capital Improvement Program, Neighborhood Master Plans, Council Resolutions, and others?

The South Logan TOD Project is aligned with many City policies to better connect land use and transportation, expand and increase the housing supply including middle housing and affordable housing, and promote anti-displacement and equitable outcomes. This includes the Comprehensive Plan (Housing Chapter), Housing Action Plan, Sustainability Action Plan, and Transit-Oriented Development Framework Study, and Logan Neighborhood Identity Plan. The proposals are implementing the South Logan TOD Plan, which was adopted by resolution on January 29, 2024 after being determined to meet all relevant policies and plans.

ORDINANCE NO. C36554

AN ORDINANCE relating to streamlining and expediting the land use review and approval process by relying on the Final Environmental Impact Statement (FEIS) for the South Logan Transit-Oriented Development (TOD) Plan by adopting a Planned Action; implementing the intent of the recently adopted by resolution South Logan TOD Plan; adopting Spokane Municipal Code (SMC) Chapter 17C.420; and amending Spokane Municipal Code (SMC) Chapter 17A.020.

WHEREAS, in 2021, the Washington State Legislature appropriated \$2.5 million for cities to facilitate transit-oriented development in areas with light rail or fixed rail systems, bus rapid transit, high-frequency bus service or park and ride lots; and

WHEREAS, the City of Spokane was one of 11 communities that received the Transit-Oriented Development Implementation (TODI) grant for \$250,000 from the Washington Department of Commerce in 2021 to facilitate transit-oriented development and increase residential capacity in areas of high-capacity transit; and

WHEREAS, the City of Spokane prepared the Transit-Oriented Development (TOD) Framework Action Plan, adopted by resolution in May 2022 under RES 2022-0039, that identifies strategies best suited to Spokane for supporting TOD along new High-Performance Transit lines, including a focus on South Logan; and

WHEREAS, the City provided opportunities for meaningful public involvement and review in the South Logan TOD Plan and EIS process, including a community meeting consistent with RCW 43.21C.440; has considered all comments received; and, as appropriate, has modified the proposal or mitigation measures in response to comments, resulting in the Preferred Alternative analyzed in the FEIS; and

WHEREAS, the *Final South Logan TOD Plan and Final Environmental Impact Statement (FEIS)* was published on November 30, 2023 for final consideration; and

WHEREAS, on January 29, 2024 Spokane City Council adopted by resolution (RES 2024-0015) the Final South Logan TOD Plan and FEIS as a declaration of the subarea's desired future condition, including the anticipated adoption of the Planned Action Ordinance at a future date; and

WHEREAS, the State Environmental Policy Act (SEPA) and its implementing regulations provide for the integration of environmental review with land use planning and project review through the designation of Planned Actions by jurisdictions planning under the Growth Management Act (GMA), including the City of Spokane (City); and

WHEREAS, Section 43.21C.440 of the Revised Code of Washington (RCW) and Sections 197-11-164 through 172 of the Washington Administrative Code (WAC) allow for and govern the adoption and application of a Planned Action designation under SEPA; and

WHEREAS, a subarea of the city consisting of the approximately 361-acre South Logan TOD project area, which is generally bounded by E Augusta Avenue and E Indiana Avenue on the north, N Perry Street and the Spokane River on the east, N Lidgerwood Street on the west, and the Spokane River on the south, as is specifically illustrated in Figure 17C.420.015-A of this Ordinance, has been identified as a Planned Action area for future redevelopment; and

WHEREAS, the designation of a Planned Action expedites the permitting process for projects of which the impacts have been previously addressed in a Final Environmental Impact Statement (FEIS); and

WHEREAS, the mitigation measures identified in the South Logan TOD FEIS, and incorporated herein by reference, together with adopted City development regulations are adequate to mitigate significant adverse impacts from development within the Planned Action Area; and

WHEREAS, the South Logan TOD Plan and FEIS identify the location, type, and amount of development that is contemplated by the Planned Action; and

WHEREAS, future projects that are implemented consistent with the Planned Action will protect the environment, benefit the public, and enhance economic development.; and

WHEREAS, on April 29, 2024, the Washington State Department of Commerce and appropriate state agencies were given the required 60-day notice of the City's intent to adopt updated development regulations; and

WHEREAS, the Spokane Plan Commission held public workshops on the provisions in this ordinance March 13, April 10, April 24, May 22, and June 12 of this year; and

WHEREAS, a SEPA Determination of Nonsignificance and Checklist were issued by Planning Services on June 12, 2024; and

WHEREAS, prior to the Plan Commission public hearing, a legal notice was published in the *Spokesman-Review* on June 12 and June 19, 2024; and

WHEREAS, on June 19, 2024, the Planning Department staff finalized their Staff Report to the Spokane Plan Commission recommending approval of the provisions of this ordinance; and

WHEREAS, on June 26, 2024, the Spokane Plan Commission held a public hearing on the provisions of this ordinance and unanimously voted to recommend approval with conditions, as outlined in the Findings of Fact, Conclusions, and Recommendation signed June 28, 2024; and

WHEREAS, the City Council of the City of Spokane finds that adopting the recitals set forth herein is in the public interest and will advance the public health, safety, and welfare.

NOW, THEREFORE, the City of Spokane does ordain as follows:

Section 1. Findings. The findings of the City of Spokane do ordain as follows:

- A. The procedural and substantive requirements of SEPA RCW 43.21C, have been complied with.
- B. The procedural requirements of GMA RCW 36.70A, have been complied with.
- C. The proposed action is consistent with the City's Comprehensive Plan as amended.
- D. All necessary public meetings and opportunities for public testimony and comment have been conducted in compliance with State law and the City's municipal code.
- E. The Spokane City Council finds and determines that regulation of land use and development is subject to the authority and general police power of the City, and the City reserves its powers and authority to appropriately amend, modify, and revise such land use controls in accordance with applicable law.
- F. The Planned Action FEIS adequately identifies and addresses the probable significant environmental impacts associated with the type and amount of development planned to occur in the designated Planned Action Area.
- G. The mitigation measures identified in the Planned Action FEIS, attached to this Ordinance as Exhibit A, and incorporated herein by reference, together with adopted City development regulations are adequate to mitigate significant adverse impacts from development within the Planned Action Area.
- H. The South Logan TOD Plan and Planned Action FEIS identify the location, type, and amount of development that is contemplated by the Planned Action.
- I. Future projects that are implemented consistent with the Planned Action will protect the environment, benefit the public, and enhance economic development.
- J. The City provided multiple opportunities for meaningful public involvement and review in the South Logan Subarea Plan and Planned Action FEIS processes, including a community meeting consistent with RCW 43.21C.440; has considered all comments received; and, as appropriate, has modified the proposal or mitigation measures in response to comments.

- K. Essential public facilities, as defined in RCW 36.70A.200 are excluded from the Planned Action as designated herein and are not eligible for review or permitting as planned action projects unless they are accessory to or part of a project that otherwise qualifies as a planned action project.
- L. The designated Planned Action Area is located entirely within an Urban Growth Area and is smaller than the overall City boundaries.
- M. Implementation of the mitigation measures identified in the Planned Action FEIS will provide for adequate public services and facilities to serve the proposed Planned Action Area.

Section 2. That there is adopted Chapter 17C.420 SMC to read as follows:

Chapter 17C.420 South Logan TOD Planned Action
17C.420.010 Purpose

The purposes of this chapter are to:

- A. Designate the South Logan TOD Subarea shown in Figure 17C.420.015-A of this Chapter as a Planned Action Area for purposes of environmental review and permitting of designated Planned Action projects pursuant to RCW.43.21C.440;
- B. Combine environmental analysis, land use plans, development regulations, and City codes and ordinances together with the mitigation measures in the South Logan TOD Final Environmental Impact Statement (FEIS) to mitigate environmental impacts and process Planned Action development applications in the Planned Action Area;
- C. Confirm that the South Logan TOD FEIS meets the requirements of a Planned Action FEIS pursuant to SEPA;
- D. Establish criteria and procedures for the designation of certain projects within the Planned Action Area as Planned Action projects consistent with RCW 43.21C.440;
- E. Provide clear definition as to what constitutes a Planned Action project within the Planned Action Area, identify the criteria for Planned Action project approval, and determine how development project applications that qualify as Planned Action projects will be processed by the City;
- F. Streamline and expediate the land use permit review process by relying on the South Logan TOD FEIS; and
- G. Apply the mitigation framework contained in this Ordinance for the processing of Planned Action project applications and incorporate the applicable mitigation

measures into the underlying project permit conditions in order to address the impacts of future development contemplated by this Ordinance.

17C.420.015 Procedures and Criteria for Evaluating and Determining Projects as Planned Actions

To qualify for a Planned Action designation, a project application shall comply with the following procedures and criteria for evaluation.

A. Planned Action Area.

The Planned Action designation shall apply to the approximately 342-acre South Logan TOD area, which is generally bounded by E Augusta Avenue and E Indiana Avenue on the north, N Perry Street and the Spokane River on the east, N Lidgerwood Street on the west, and the Spokane River on the south, and that is specifically shown in Figure 17C.420.015-A, "Planned Action Area."

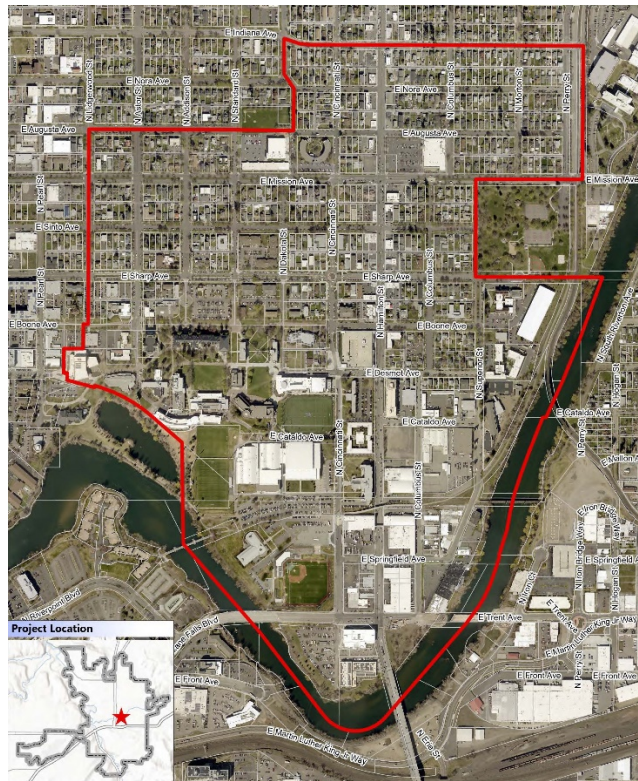

Figure 17C.420.015-A: Map of Planned Action Area

B. Environmental Document.

A Planned Action determination for a site-specific implementing project application shall be based on the environmental analysis contained in the South

Logan TOD Final EIS adopted by the City on January 29, 2024 (RES 2024-0015), which adequately identified and addressed environmental impacts of the Planned Action. The mitigation measures contained in the FEIS, [Exhibit A](#), are based upon the findings of the South Logan TOD EIS and shall, along with adopted City regulations, provide the framework that the City will use to review and to impose appropriate conditions on qualifying Planned Action projects.

C. Planned Action Projects Designation.

Land uses and activities described in the South Logan TOD FEIS, subject to the thresholds described in subsection D of this section and the mitigation measures contained in [Exhibit A](#), are designated Planned Actions or Planned Action projects pursuant to [RCW 43.21C.440](#) and [WAC 197-11-172](#) (“Planned Action Project”). A development application for a site-specific Planned Action project located within the South Logan TOD Planned Action area that meets the criteria set forth in subsection D of this section and applicable laws, codes, development regulations and standards, may be designated a Planned Action Project pursuant to the process in SMC Section 17C.420.020.

D. Planned Action Qualifications.

The following thresholds shall be used to determine if a site-specific development proposed within the South Logan TOD Planned Action area qualifies as a Planned Action Project and has had its environmental impacts evaluated in the South Logan TOD FEIS:

1. Qualifying Uses.

a. Planned Action Categories.

The primary land uses and levels of development as envisioned in the South Logan TOD Preferred Alternative and as reviewed in the South Logan TOD FEIS, along with conditional and accessory uses permitted in the associated zones, are considered Planned Actions. The primary uses include residential, commercial, and mixed-use development.

2. Planned Action Project Primary Uses.

A Planned Action Project may be a single Planned Action use, or a combination of Planned Action uses within a mixed-use development. A land use can qualify as a Planned Action Project when:

- a. It is within the Planned Action Area; and
 - b. It complies with the land use plan map designation of the property identified in the South Logan TOD Preferred Alternative or has a lower intensity designation; and
 - c. Is within one or more of the primary uses described in Subsection D.1 above; or
 - d. It is a permitted accessory use or appurtenant to a permitted use.
3. Public Services.

The following public services, infrastructure, and utilities may also qualify as Planned Action Projects: streets and non-motorized improvements, utilities, parks, trails, civic, cultural, governmental, and similar facilities developed consistent with the South Logan TOD FEIS mitigation measures, City design standards, critical area regulations, and the Spokane Municipal Code.

4. Development Thresholds.

- a. The following amount of increase in housing is contemplated by the Planned Action:

Increase in New Housing Units ¹	2,954
Associated Population Increase	6,735

¹ Includes equivalent housing added in college dormitories.

- b. If future development proposals in the South Logan TOD Planned Action area exceed the development thresholds specified in this chapter, further environmental review may be required pursuant to [WAC 197-11-172](#). Further, if the proposed development would alter the assumptions and analysis in the South Logan TOD FEIS, further environmental review may be required.

5. Building Heights.

Building heights shall not exceed the maximums identified and reviewed in the South Logan TOD Final FEIS and South Logan TOD Plan.

6. Transportation.

a. The Preferred Alternative is anticipated to generate approximately 928 new PM peak-hour vehicle trips. This equates to approximately 9 percent higher traffic volumes in the area compared to the 2045 No Action alternative.

b. Trip Threshold.

Uses or activities that would exceed the forecasted trips shown above would not qualify as Planned Actions and would require additional transportation review.

c. City Engineer Discretion.

The City Engineer or their designee shall have discretion to determine incremental and total trip generation, consistent with the Institute of Traffic Engineers (ITE) Trip Generation Manual (latest edition) or an alternative manual accepted by the City Engineer, for each project permit application proposed under this planned action.

d. Transportation Improvements and Mitigation.

i. On-Site and Off-Site Improvements.

The Planned Action may require on-site and off-site transportation improvements to mitigate significant adverse impacts as development occurs. These transportation improvements are identified in the South Logan TOD FEIS and South Logan TOD Plan. The City shall have the discretion to adjust the allocation of responsibility for required improvements between individual Planned Action projects based on their identified impacts.

ii. Hamilton and Trent.

The intersection of N Hamilton Street/E Trent Avenue is forecasted to operate at LOS E during the 2045 No Action and LOS F with full development of Planned Action projects. Any development must implement measures to restore the LOS and delay to its pre-development level of LOS E.

7. Elements of the Environment and Degree of Impacts.

A proposed project that would result in a significant change in the type or degree of impacts to any of the elements of the environment analyzed in the South Logan TOD FEIS, EIS addendum, and/or supplemental EIS, would not qualify as a Planned Action.

8. Changed Conditions.

Should environmental conditions change significantly from those analyzed in the FEIS, the City's PAO Responsible Official may determine that the Planned Action designation is no longer applicable until a supplemental environmental review is conducted.

9. Additional Mitigation Fees.

The City may adopt and apply such other fees as may be deemed necessary and appropriate to mitigate impacts to other capital facilities in the Planned Action area and to accommodate planned growth. Such fees, if adopted, shall be in addition to any fees required in subsection (D)(6)(d) of this section, and shall apply only to required improvements that are not addressed in this subsection.

10. Inadvertent Discovery Plan.

An Inadvertent Discovery Plan (IDP) should be implemented into the scope of work for all projects within the Planned Action area. The IDP should outline procedures to perform in the event of a discovery of archaeological materials or human remains. The IDP should always be kept at the project site during all project activities. If any artifacts or human remains are found upon excavation, the Tribal Historic Preservation Office (THPO), Washington State Department of Archaeology and Historic Preservation (DAHP), and Spokane Historic Preservation Office shall be immediately notified and the work in the immediate area cease.

11. Historic Preservation Design Review.

Properties individually placed on the Spokane Register of Historic Places or located within one of Spokane's designated historic districts must meet all requirements of the Spokane Historic Preservation Office, including obtaining a Certificate of Appropriateness from the Spokane Historic Landmarks Commission or the Historic Preservation Officer for proposed changes or additions to historic structures when necessary.

12. Demolitions.

Buildings fifty years of age or greater at time of demolition permit submittal shall provide a Level 2 Site Inventory Form unless determined by the Historic Preservation Officer and Planning Director to not be of historic significance.

13. Shoreline Master Program.

Areas within the Planned Action area subject to the Shoreline Master Program are not exempt from permitting or SEPA review through the FEIS and must comply with Chapter 17E.060 SMC Shoreline Regulations.

14. Uses.

Drive-thru facilities, including accessory drive-thru features, are not exempt from SEPA review and do not qualify as Planned Action Projects.

E. Planned Action Review Criteria.

1. The City's PAO Responsible Official may designate as "Planned Actions," pursuant to RCW 43.21C.030, applications that meet all of the following conditions:
 - a. The proposal is located within the Planned Action Area identified in SMC 17C.420.015, or is an off-site improvement directly related to the proposed development within the Planned Action Area; and
 - b. The proposed uses and activities are consistent with those described in the FEIS and subsection D of this section; and
 - c. The proposal is within the Planned Action thresholds and other criteria of subsection D of this section; and
 - d. The proposal is consistent with the City of Spokane Comprehensive Plan and the South Logan TOD Plan; and
 - e. The proposal's significant adverse environmental impacts have been identified in the South Logan TOD FEIS; and
 - f. The proposal's significant impacts have been mitigated by the application of measures identified in Exhibit A, and other applicable City regulations, together with any modifications or variances or special permits that may be required; and

- g. The proposal complies with all applicable local, state, and/or federal laws and regulations, and the PAO Responsible Official determines that these constitute adequate mitigation; and
 - h. Adequate infrastructure improvements are in place, or will be in place at completion of the project, to support the development of the project; and
 - i. The proposal is not an essential public facility as defined by RCW 36.70A.200, unless the essential public facility is part of or accessory to a residential, office, school, commercial, recreational, or service that is designated as a Planned Action.
 2. The City shall base its decision on designation as a Planned Action project on review of a Planned Action checklist, or an alternative form developed consistent with applicable provisions of Chapter 43.21C RCW, and review of the application and supporting documentation.
 3. A proposal that meets the criteria of this section shall be considered to qualify and be designated as a Planned Action, consistent with the requirements of RCW 43.21C.440, WAC 197-11-164 et seq., and this chapter.

F. Effect of Planned Action.

1. Designation as a Planned Action project means that a qualifying proposal has been reviewed in accordance with this chapter and found to be consistent with its development parameters and thresholds, and with the environmental analysis contained in the South Logan TOD FEIS.
2. Upon determination by the City's PAO Responsible Official that the proposal meets the criteria of section (D) of this section and qualifies as a Planned Action, the proposal shall not require a SEPA threshold determination, preparation of an EIS, or be subject to further review pursuant to SEPA.

17C.420.020 Planned Action Permit Process and Application

Applications for Planned Actions shall be reviewed pursuant to the following process:

- A. Applications shall be made on forms provided by the City, including an approved Planned Action Checklist, and shall meet the applicable requirements of the Spokane Municipal Code.

- B. After the City receives a complete application, the PAO Responsible Official shall determine whether the project qualifies as a Planned Action Project under this chapter.
- C. Once a project is determined to qualify as a Planned Action Project under this chapter, the City shall:
 - 1. Notify the applicant and the project shall proceed in accordance with the applicable permit review procedures; and
 - 2. Notify Spokane Tribe of Indians, Spokane Historic Preservation Office, internal City Departments, utility providers, and other partner agencies as deemed appropriate by the assigned project manager of the pending development under South Logan TOD FEIS. The notice required by this section may be combined with the public notice required or provided with the underlying permit and may take the form of the environmental checklist or other project review form. Notice provided shall not be less than 14 days.
- D. If a project does not qualify as a Planned Action under this chapter, the City shall notify the applicant. The notice shall describe the elements of the application that result in failure to qualify as a Planned Action.
 - 1. Projects that fail to qualify as Planned Actions may incorporate or otherwise use relevant elements of the South Logan TOD Plan and FEIS to meet SEPA requirements. The City may limit the scope of the SEPA review for the non-qualifying project to those issues and environmental impacts not previously addressed in the Planned Action.

17C.420.025 Monitoring and Review

- A. The City shall monitor the progress of development in the designated Planned Action area to ensure that it is consistent with the assumptions of this chapter and the South Logan TOD FEIS regarding the type and amount of development and associated impacts, and with the mitigation measures and improvements planned for the Planned Action Area.
- B. This Planned Action Ordinance shall be reviewed no later than five (5) years from its effective date to determine the continuing relevance of its assumptions and findings with respect to environmental conditions in the Planned Action area, the impacts of development, and required mitigation measures. Based upon this review, the City may propose amendments to this ordinance and/or may supplement or revise the South Logan TOD FEIS.

Section 3. That SMC Section 17A.20.160 is amended to read as follows:

17A.20.160 “P” Definitions

A. Painted Wall Highlights.

[See SMC 17C.240.015.](#)

B. Painted Wall Sign.

[See SMC 17C.240.015.](#)

C. PAO Responsible Official.

The Planning Director, serving in the capacity of administrative official of the lead agency.

D. Parcel.

See “Lot” ([SMC 17A.020.120](#)).

E. Parkway.

A thoroughfare designated as a collector or arterial, with a median reflecting the park-like character implied in the name - [SMC 17D.050A.040.U](#).

F. Party of Record.

Any person who has appeared at a hearing of the hearing examiner by presenting testimony or making written comment.

G. Paved Area.

1. An uncovered, hard-surfaced area or an area covered with a perforated hard surface (such as “Grasscrete”) that is able to withstand vehicular traffic or other heavy-impact uses.

2. Graveled areas are not paved areas.

H. Pedestrian Buffer Strips (PBS).

A hard-surfaced or planted area(s) between travel or parking lanes and sidewalks, also called planting strips. PBS improves safety by separating vehicles and pedestrians and provide space for drainage, street trees and snow storage.

I. Pedestrian Path.

A continuous, unobstructed, reasonably direct route between an on-site parking lot and a Primary Building Entry designed and suitable for pedestrian use. Minimum requirements for Pedestrian Paths are listed in [Section 17C.123.040](#) of the FBC.

J. Pedestrian-Scaled Fixtures (lighting).

Pole-mounted light fixtures placed and designed to illuminate foot-traffic areas including exterior lots, pathways or sidewalks. For purposes of the HFBC, Pedestrian-Scaled Fixtures are defined by height as measured from ground to bottom of shade or bulb.

K. Pedestrian-Scaled Signs.

[See SMC 17C.240.015.](#)

L. Pedestrian Street.

1. A street designated on the official zoning map as a pedestrian street where development standards are required to promote a pedestrian friendly street. Pedestrian streets offer a pleasant and safe walking environment. Design features include minimal interruptions of the sidewalk by driveways, publicly usable site furnishing such as benches, tables, and bike racks, and visually interesting buildings close to the sidewalk.

M. Performance Guarantee.

A “financial guarantee” providing for and securing to the City the actual construction and installation of the required improvements.

N. Performance/Warranty Retainer.

A “financial guarantee” both providing for and securing to the City the actual construction and installation of such improvements, and securing to the City the successful operation of the improvements for two years after the City’s final inspection and acceptance of the improvements.

O. Permanent Erosion and Sediment Control Measures.

A combination of plants, mulch, sod, matting, erosion control blankets, and permanent structures that will provide long-term soil stabilization.

P. Permanent Sign.

[See SMC 17C.240.015.](#)

Q. Permanent Stabilization.

See Permanent Erosion and Sediment Control Measures.

R. Permeable Sediment.

Sediment permitting the flow of water.

S. Person.

Any natural person, whether acting individually or in a representative capacity, partnership, joint venture, corporation, or other legal entity.

T. Pier.

Any platform structure, fill, or anchored device in or floating upon water bodies to provide moorage for watercraft engaged in commerce, including, but not limited to, wharves, mono-buoys, quays, ferry terminals, and fish weighing station.

U. Planned Action.

A Planned Action means one or more types of project action that:

1. Are designated Planned Actions by an ordinance or resolution; and
2. In conjunction with, or to implement, an adopted comprehensive plan or subarea plan that have had the significant impacts adequately addressed in an Environmental Impact Statement under the requirements of WAC 197-11-64; and
3. Is exempt from additional SEPA review for all elements covered under the Environmental Impact Statement of the adopted comprehensive plan or subarea plan.
4. Is defined in WAC 197-11-164.

V. Planned Capacity.

For all capital facilities, except transportation, capacity for a concurrency facility that does not exist, but for which the necessary facility construction, expansion, or modification project is contained in the current adopted City of Spokane comprehensive plan, capital improvement program and scheduled to be completed within six years. (RCW 36.70A.020).

W. Planned Capacity for Transportation Facilities.

Capacity for transportation facilities, including roads and transit, that does not exist, but where transportation improvements or strategies to accommodate the impacts of development are made concurrent with the development.

1. These strategies may include:
 - a. increased public transportation service,
 - b. ride sharing programs,
 - c. demand management, and
 - d. other transportation systems management strategies.
2. For transportation facilities, “concurrent with the development” shall mean that improvements or strategies are in place at the time of development, or that a financial commitment is in place to complete the improvements or strategies within six years (RCW 36.70A.070(6)(b)).

X. Planned Unit Development (PUD).

1. A planned unit development is a project permit for an overlay zone, approved by the hearing examiner, which does not fully comply with all of the development standards of the base zone in which it is located, but is approved based on superior or innovative design
2. The City may permit a variety of types, design, and arrangement of structures and enable the coordination of project characteristics with features of a particular site in a manner consistent with the public health, safety, and welfare.

Y. Plans.

Planning documents, which are developed by the various departments of the City, pertaining to the orderly development of public facilities.

Z. Planting Zone.

Area for street trees, ground cover or other plantings; typically included herein as a portion of overall sidewalk width reserved for locating permanent trees and tree grates.

AA. Plat – Final.

A map or representation of a subdivision, showing thereon the division of a tract or parcel of land into lots, blocks, streets, alleys, or other divisions and dedications

and containing all elements and requirements set forth in this chapter and chapter 58.17 RCW.

BB. Plat – Preliminary.

1. A neat and approximate drawing of a proposed subdivision showing the general layout of streets, alleys, lots, blocks, and other elements of a subdivision required by this chapter and chapter 58.17 RCW.
2. The preliminary plat shall be the basis for the approval or disapproval of the general layout of a subdivision.

CC. Plaza.

Areas generally open to the public on a controlled basis and used for passive recreational activities and relaxation.

Plazas are paved areas typically provided with amenities, such as seating, drinking, and ornamental fountains, art, trees, and landscaping, for use by pedestrians.

DD. Plinth.

The base or platform upon which a building wall or column appears to rest, helping establish pedestrian-scaled elements and aesthetically tying the building to the ground.

EE. Pollutant.

Any substance which is prohibited or limited by applicable laws or regulations, which is released or discharged in conjunction with development. Any substance that causes or contributes to violation of air, land, or water quality standards, released or discharged.

FF. Pollution.

Contamination, or other alteration of the physical, chemical, or biological properties of air, land, water or wetlands, or such discharge of any liquid, gaseous, solid, radioactive, or other substance into air, land, water, or wetlands as will or is likely to cause a nuisance or render such air, land, water, or wetlands harmful, detrimental, or injurious to the public health, safety, or welfare, or to domestic, commercial, industrial, agricultural, recreational, or other legitimate beneficial uses, or to livestock, wildlife, fish, native vegetation, or other aquatic life.

GG. Potential Geologically Hazardous Areas.

Areas designated on maps maintained in the City's planning and economic development services department. They are classified "potential" because they have not been confirmed by field investigation nor do they necessarily include the full extent of all geologically hazardous areas within the City. The maps are intended to alert property owners, purchasers, developers, etc., to the possible existence of significant geological hazards, which may warrant further geotechnical study.

HH. Practicable Alternative.

An alternative that is available and capable of being carried out after taking into consideration cost, existing technology, and logistics in light of overall project purposes and having less impact to critical areas. It may involve using an alternative site in the general region that is available to the applicant and may feasibly be used to accomplish the project.

II. Predevelopment Meetings.

Meetings between City or agency staff and an applicant or their representatives prior to formal submission of a detailed application. They are intended to provide an overview of the regulatory requirements, application process, and procedural submission requirements.

JJ. Principal Buildings.

Where multiple buildings occupy a single lot, those buildings that are associated with the prevailing use of that site.

KK. Primary Building Entry.

Access or entrance of first rank, importance or value, visually associated with the prevailing ground-floor use of a building.

LL. Primary Building Walls.

Any exterior building wall that faces a street and contains a public entrance to the occupant's premises or tenant space. If an individual tenant space does not have a street facing wall, or does not have a street facing wall containing a public entrance, then the primary building wall for that individual tenant space is any wall containing a public entrance that faces a parking area on the site. (See Figure 1, [SMC 17C.240.130](#), Primary Building Walls)

MM. Primary Container.

The container that is in direct contact with the material of concern during the course of normal transport, use, or storage.

NN. Primary Drainage Basin.

The basin of the stream or tributary within which a project is proposed, not including basins of major tributaries. For the purpose of this regulation the primary drainage basin of:

1. Latah Creek is not a part of the primary drainage basin of the Spokane River,
2. Marshall Creek is not a part of the primary drainage basin of Latah Creek.

OO. Primary Structure.

1. A structure or combination of structures of chief importance or function on a site. In general, the primary use of the site is carried out in a primary structure.
2. The difference between a primary and accessory structure is determined by comparing the size, placement, similarity of design, use of common building materials, and the orientation of the structures on a site.

PP. Primary Use.

1. An activity or combination of activities of chief importance on the site. One of the main purposes for which the land or structures are intended, designed or ordinarily used.
2. A site may have more than one primary use.

QQ. Principal Arterials.

A street serving major activity centers, providing a high degree of mobility and serving the longest trip demands within the urban area.

RR. Priority Habitats.

Habitat areas determined by WDFW to have unique or significant value to many species and that meet one or more of the following criteria:

1. High wildlife density.
2. High species diversity.
3. Important wildlife breeding habitat.

4. Important wildlife seasonal ranges.
5. Important movement corridors.
6. Limited availability.
7. High vulnerability to habitat alteration.

SS. Priority Species.

A wildlife species requiring protective measures for their perpetuation due to their population status, their sensitivity to habitat alteration, and/or their recreational importance.

TT. Private Street.

Roadway which is not controlled or maintained by a public authority, and which serve two or more properties.

UU. Project Permit or Project Permit Application.

Any land use or environmental permit or license required for a project action, including, but not limited to, building permits, short plats, subdivisions, binding site plans, planned unit developments, conditional uses, shoreline substantial development permits, site plan review, permits, or approvals required by the critical area ordinance, and site specific rezones authorized by a comprehensive plan or subarea plan, but excluding the adoption or amendment of a comprehensive plan, subarea plan, or development regulations, except as otherwise specifically identified under RCW 36.70B.140.

VV. Projecting Sign.

[See SMC 17C.240.015.](#)

WW. Protected Species.

A general classification of animals by WDFW that includes all those species not classified as listed, game, fur-bearing, or non-protected. This also includes all birds not classified as game or non-protected.

XX. Proximity.

That two or more properties are either adjacent or separated by a street or alley.

YY. Public Access.

The public's right to get to and use the City's public waters, the water/land interface and associated shoreline area. It includes physical access that is either lateral (areas paralleling the shore) or perpendicular (an easement or public corridor to the shore), and/or visual access facilitated by means such as scenic streets and overlooks, viewing towers, and other public sites or facilities.

ZZ. Public Facilities.

Any City-owned, operated, or contracted public facility or service in whole, or in part, whether existing or planned, including, but not limited to:

1. parks,
2. recreation facilities,
3. playgrounds,
4. streets,
5. transportation facilities,
6. open spaces,
7. fire facilities,
8. storm water drainage ponds, and
9. all such appurtenances and improvements.

AAA. Public Property.

Any City-owned real property, air space, or other interest in real estate, including streets, alleys, or other public rights-of-way, owned by or controlled by this municipality or any other governmental unit.

BBB. Public Way.

1. A dedicated "public way" is a tract of land:
 - a. conveyed or reserved by deed,
 - b. dedicated by plat, or
 - c. acquired by decree of court,

- d. which has been accepted and dedicated by action of the city council to the public right-of-way and for secondary use as an easement for public utilities.
2. An "alley" is a public way, usually not exceeding sixteen feet in width, designed or intended to provide secondary access to abutting properties.

PASSED by the City Council on _____.

Council President

Attest:

Approved as to form:

City Clerk

Assistant City Attorney

Mayor

Date

Effective Date

**CITY OF SPOKANE PLAN COMMISSION
FINDINGS OF FACT, CONCLUSIONS, AND RECOMMENDATIONS
REGARDING THE SOUTH LOGAN TOD PLANNED ACTION ORDINANCE**

A recommendation of the City of Spokane Plan Commission to the City Council to approve a new Chapter to the Spokane Municipal Code titled South Logan TOD Planned Action. The proposal adopts the Unified Development Code (UDC) Chapter 17C.420 and amends Chapter 17A.020 to implement the adopted South Logan Transit-Oriented Development Plan.

FINDINGS OF FACT:

- A. The City of Spokane adopted a Comprehensive Plan in May of 2001 that complies with the requirements of the Growth Management Act (GMA) as set forth in RCW 36.70A.
- B. In 2021, the Washington State Legislature appropriated \$2.5 million for cities to facilitate transit-oriented development planning in areas with light rail or fixed rail systems, bus rapid transit, high frequency bus service or park and ride lots.
- C. The City of Spokane prepared the Transit-Oriented Development (TOD) Framework Action Plan, adopted by resolution in May 2022 under RES 2022-0039, that identifies strategies best suited to Spokane for supporting TOD along new High-Performance Transit lines, including a focus on South Logan.
- D. The City provided opportunities for meaningful public involvement and review in the South Logan TOD Plan and EIS process, including a community meeting consistent with RCW 43.21C.440; has considered all comments received; and, as appropriate, has modified the proposal or mitigation measures in response to comments, resulting in the Preferred Alternative analyzed in the Final Environmental Impact Statement (FEIS).
- E. The *Final South Logan TOD Plan* and *Final Environmental Impact Statement (FEIS)* were published on November 30, 2023 for final consideration.
- F. On January 29, 2024 Spokane City Council adopted by resolution (RES 2024-0015) the Final South Logan TOD Plan and FEIS as a declaration of the subarea's desired future condition, including the anticipated adoption of the Planned Action Ordinance at a future date.
- G. The State Environmental Policy Act (SEPA) and its implementing regulations provide for the integration of environmental review with land use planning and project review through the designation of Planned Actions by jurisdictions planning under the Growth Management Act (GMA), including the City of Spokane (City).
- H. Section 43.21C.440 of the Revised Code of Washington (RCW) and Sections 197-11-164 through 172 of the Washington Administrative Code (WAC) allow for and govern the adoption and application of a Planned Action designation under SEPA.
- I. A subarea of the city consisting of the approximately 361-acre South Logan TOD project area, which is generally bounded by E Augusta Avenue and E Indiana Avenue on the

north, N Perry Street and the Spokane River on the east, N Lidgerwood Street on the west, and the Spokane River on the south, has been identified as a Planned Action area for future redevelopment.

- J. The designation of a Planned Action expedites the permitting process for projects identified and which of the impacts have been previously addressed in a FEIS, with the mitigation measures identified in the South Logan TOD FEIS, together with adopted City development regulations, are adequate to mitigate significant adverse impacts from development within the Planned Action Area.
- K. The draft amendments relied on the 20-month planning process and extensive public engagement that occurred as part of the development of the South Logan TOD Plan. Outreach and public communication specifically about South Logan TOD Implementation began in February 2024 and included the following among others:
 - 1. Logan Neighborhood Council meeting presentation on February 13, 2024;
 - 2. Plan Commission Workshops on March 13, April 10, April 24, May 8, May 22, and June 12, 2024;
 - 3. Various community tabling events on March 19, April 9, and May 18, 2024;
 - 4. A virtual information session on April 30, 2024;
 - 5. Coffee Chat pop-up events on May 4, May 23, and June 1, 2024;
 - 6. Regular South Logan TOD newsletter and webpage updates, as well as City of Spokane newsletter and social media posts.
- L. Public comment, as well as agency and department comments, received prior to the June 26, 2024, Plan Commission public hearing were included in the staff report.
- M. On March 13, April 10, April 24, May 8, May 22, and June 12, 2024, the Spokane Plan Commission held workshops to discuss draft language, receive updates on public feedback as well as city department and agency comments, and review and evaluate with city staff alternatives to proposed text changes.
- N. On April 29, 2024, the Washington State Department of Commerce and appropriate state agencies were given the required 60-day notice of the City's intent to adopt updated development regulations pursuant to RCW 36.70A.106.
- O. On April 29, 2024, a Notice of Intent to Adopt and Request for SEPA agency comments was issued for the draft code pertaining to the proposed South Logan TOD Implementation text amendments. The comment period ended on May 13, 2024. No comments were received.

Findings of Fact, Conclusion, and Recommendation

- P. The SEPA Determination of Nonsignificance and Checklist were issued by Planning Services on June 12, 2024. The comment period ended on June 26, 2024. No comments were received.
- Q. Prior to the Plan Commission public hearing, a legal notice was published in the *Spokesman-Review* on June 12 and June 19, 2024; and
- R. The proposed text amendments were drafted and reviewed pursuant to the process established under RCW 36.70A.370 to ensure that the proposed changes will not result in unconstitutional takings of private property.
- S. Amendments to Title 17 are subject to review and recommendation by the Plan Commission.
- T. On June 26, 2024, the Spokane Plan Commission held a public hearing on the proposed text amendments, including the taking of verbal testimony, and closed the public record on that date.
- U. Public comment, as well as agency and department comments, received prior to the June 26, 2024 Plan Commission public hearing were included in the staff report.
- V. During deliberations held on June 26, 2024, the Plan Commission discussed the concerns expressed in public comments and testimony about public safety within the South Logan Subarea.
- W. Except as otherwise indicated in the above findings, the Spokane Plan Commission adopts the findings and analysis set forth in the staff report prepared for the proposal.
- X. The Spokane Plan Commission finds that the proposed text amendments meet the decision criteria established in SMC 17G.025.010(G).

CONCLUSIONS:

Based upon the draft text amendments, staff report and analysis (which is hereby incorporated into these findings, conclusions, and recommendations), SEPA review, agency and public comments received, and public testimony presented, the Spokane Plan Commission makes the following conclusions with respect to the text amendments to the Hamilton Form-Based Code:

1. The Plan Commission finds that the proposed amendments bear a substantial relation to the public health, safety, welfare, and protection of the environment pursuant to the requirements outlined in SMC 17G.025.010(G).
2. The proposed text amendments will implement the goals and policies of the Comprehensive Plan.
3. The proposed text amendments will implement the adopted South Logan Transit-Oriented Development Plan.

Findings of Fact, Conclusion, and Recommendation

4. Interested agencies and the public have had extensive opportunities to participate throughout the process and persons desiring to comment were given an opportunity to comment.
5. SEPA review was completed for the proposal, and pursuant to SEPA, any adverse environmental impacts associated with the planned action has mitigation measures for each element of the environment. The Planned Action (RCW 43.21C.440), is used to facilitate future growth by streamlining the environmental review for projects that are consistent with the Subarea Plan.
6. Plan Commission concludes that the intent of the including neighborhood councils to the list of entities that receive notice of applications was to give neighborhood councils standing and the ability to advocate for their neighborhood residents. As entities of standing, neighborhood councils should assume the responsibility of proactively communicated with their residents about pertinent all-city or neighborhood-specific development applications.
7. The Plan Commission finds that the proposed amendments are consistent with the applicable provisions of the Comprehensive Plan, particularly the following adopted goals and policies:
 - a. Chapter 3: Land Use – Goal 1 – Citywide Land Use, Policy LU 1.4 Higher Intensity Residential Areas
 - b. Chapter 3: Land Use – Goal 3 – Efficient Land Use, Policy LU 3.1 Coordinated and Efficient Land Use
 - c. Chapter 3: Land Use – Goal 3 – Efficient Land Use, Policy LU 3.2 Centers and Corridors
 - d. Chapter 3: Land Use – Goal 3 – Efficient Land Use, Policy 3.5 Mix of Uses in Centers
 - e. Chapter 3: Land Use – Goal 4 – Transportation, Policy LU 4.1 Land Use and Transportation
 - f. Chapter 3: Land Use – Goal 4 – Transportation, Policy LU 4.6 Transit-Supported Development
 - g. Chapter 3: Land Use – Goal 5 – Development Character, Policy LU 5.1 Built and Natural Environment
 - h. Chapter 3: Land Use – Goal 5 – Development Character, Policy LU 5.5 Complementary Development
 - i. Chapter 6: Housing – Goal H1 – Housing Choice and Diversity, Policy H 1.4 Use of Existing Infrastructure
 - j. Chapter 6: Housing – Goal H1 – Housing Choice and Diversity, Policy H 1.7 Socioeconomic Integration

Findings of Fact, Conclusion, and Recommendation

- k. Chapter 6: Housing – Goal H1 – Housing Choice and Diversity, Policy H 1.11 Access to Transportation
 - l. Chapter 8: Urban Design and Historic Presentation – Goal DP 1 – Price and Identity, Policy DP 1.2 New Development in Established Neighborhoods
 - m. Chapter 8: Urban Design and Historic Preservation – Goal DP 2 – Urban Design, Policy DP 2.2 Design Guidelines and Regulations
 - n. Chapter 8: Urban Design and Historic Preservation – Goal DP 2 – Urban Design, Policy DP 2.6 Building and Site Design
 - o. Chapter 8: Urban Design and Historic Preservation – Goal DP 2 – Urban Design, Policy DP 2.7 Historic District and Sub-Area Design Guidelines
 - p. Chapter 8: Urban Design and Historic Preservation – Goal DP 2 – Urban Design, Policy DP 2.12 Infill Development
 - q. Chapter 8: Urban Design and Historic Preservation – Goal DP 2 – Urban Design, Policy 2.13 Parking Facilities Design
 - r. Chapter 11: Neighborhoods – Goal N 4 – Traffic Circulation, Policy N 4.7 Pedestrian Design
8. The Plan Commission recognizes the concerns expressed by community members about public safety within the South Logan Subarea. While the Plan Commission urges continued community collaboration with public safety and code enforcement officials, the body recognizes the positive impact that transit-oriented and pedestrian-oriented development can have on public safety within the built environment. Increased density and mix of uses made possible with amendments to the Center and Corridor zones, higher intensity residential zones, and height allowances, as well as street activation as called for in the Hamilton Form-Based Code, encourage more eyes on the street and have been found to have a positive effect on safety and walkability.

RECOMMENDATION:

In the matter of the ordinance pertaining to the Hamilton Form-Based Code, amending the Unified Development Code of the City of Spokane:

1. By a vote of seven to zero, the City of Spokane Plan Commission recommends to the Spokane City Council the **APPROVAL** of the proposed adoption of Chapter 17C.420 and amendments to Chapter 17A.020 amendments.
2. The City of Spokane Plan Commission authorizes the Plan Commission President to prepare and sign on the Commission's behalf a written decision setting forth the Plan Commission's findings, conclusions, and recommendations on the proposed amendments.

Greg Francis
Greg Francis (Jun 27, 2024 17:44 PDT)

Greg Francis, President
Spokane Plan Commission

Jun 27, 2024
click or tap to enter a date.

PC Findings and Conclusions_ Planned Action Ordinance

Final Audit Report

2024-06-28

Created:	2024-06-27
By:	AMANDA KIEHN (AKIEHN@SPOKANECITY.ORG)
Status:	Signed
Transaction ID:	CBJCHBCAABAxAxkO4gC06qyIVwSaOdp6TTRuPxHjA-_QV

"PC Findings and Conclusions_ Planned Action Ordinance" History

 Document created by AMANDA KIEHN (AKIEHN@SPOKANECITY.ORG)

2024-06-27 - 10:05:44 PM GMT

 Document emailed to gfrancis@spokanecity.org for signature

2024-06-27 - 10:06:22 PM GMT

 Email viewed by gfrancis@spokanecity.org

2024-06-28 - 0:44:16 AM GMT

 Signer gfrancis@spokanecity.org entered name at signing as Greg Francis

2024-06-28 - 0:44:34 AM GMT

 Document e-signed by Greg Francis (gfrancis@spokanecity.org)

Signature Date: 2024-06-28 - 0:44:36 AM GMT - Time Source: server

 Agreement completed.

2024-06-28 - 0:44:36 AM GMT

**Agenda Sheet for City Council:****Committee:** Urban Experience **Date:** 07/08/2024**Committee Agenda type:** Discussion**Date Rec'd**

7/8/2024

Clerk's File #

ORD C36555

Cross Ref #**Project #****Council Meeting Date:** 07/22/2024**Submitting Dept**

PLANNING & ECONOMIC

Bid #**Contact Name/Phone**

KAYCEE X6194

Requisition #**Contact E-Mail**

KDOWNNEY@SPOKANECITY.ORG

Agenda Item Type

First Reading Ordinance

Council Sponsor(s)

ZZAPPONE JBINGLE KKLITZKE

Agenda Item Name

0650 - HEIGHT CODE UPDATE ASSOCIATED WITH SOUTH LOGAN TOD

Agenda Wording

Height code update to amend SMC Sections 17C.111.230 and 17C.120.220 for South Logan TOD Implementation.

Summary (Background)

The South Logan Transit-Oriented Development (TOD) Plan, adopted by resolution on January 29, 2024, provides recommendations to support more connectivity and livability for the community, businesses, and organization in South Logan. As part of South Logan TOD Implementation, several recommendations are proposed for citywide impact. The proposed Center and Corridor code update to amend SMC Sections 17C.111.230 and 17C.120.220 to align with the goals and recommendations of the South Logan TOD

Lease? NO

Grant related? NO

Public Works? NO

Fiscal Impact

Approved in Current Year Budget? N/A

Total Cost

\$

Current Year Cost

\$

Subsequent Year(s) Cost

\$

Narrative

The S. Logan TOD Plan and FEIS, adopted by resolution on January 29, 2024, was funded through the TOD Implementation grant program via the WA Department of Commerce. Implementation of the S. Logan TOD Plan relied on on-going and regular staff resources.

Amount**Budget Account**

Neutral

\$

#

Select

\$

#

Select

\$

#

Select

\$

#

Select

\$

#

Select

\$

#



Continuation of Wording, Summary, Approvals, and Distribution

Agenda Wording

Summary (Background)

Plan and the City of Spokane Comprehensive Plan. The proposed amendments include replacing the allowed height of 70-feet with 75-feet and reducing the distance of and modifying the slope of required height transitions adjacent to R1 and R2 zones to increase the feasibility of development building to the allowed maximum height allowances. For the full code amendments please visit:

<https://my.spokanecity.org/projects/south-logan-transit-oriented-development-project/>

Approvals

<u>Dept Head</u>	GARDNER, SPENCER
<u>Division Director</u>	MACDONALD, STEVEN
<u>Accounting Manager</u>	ALBIN-MOORE, ANGELA
<u>Legal</u>	RICHMAN, JAMES
<u>For the Mayor</u>	JONES, GARRETT

Additional Approvals

Distribution List

smacdonald@spokanecity.org	kdowney@spokanecity.org
sgardner@spokanecity.org	tblack@spokanecity.org
tkimbrell@spokanecity.org	amccall@spokanecity.org

Committee Agenda Sheet

Urban Experience Committee

Committee Date	July 8, 2024
Submitting Department	Planning & Economic Development
Contact Name	KayCee Downey
Contact Email & Phone	kdowney@spokanecity.org , x6194
Council Sponsor(s)	<u>CM Zappone, CM Klitzke and CM Bingle</u>
Select Agenda Item Type	<input type="checkbox"/> Consent <input checked="" type="checkbox"/> Discussion Time Requested: 5 minutes
Agenda Item Name	Height Code Update Associated with South Logan TOD Implementation
Proposed Council Action	<input checked="" type="checkbox"/> Approval to proceed to Legislative Agenda <input type="checkbox"/> Information Only
Summary (Background)	<p>The South Logan Transit-Oriented Development (TOD) Plan, adopted by resolution on January 29, 2024, provides recommendations to support more connectivity and livability for the community, businesses, and organization in South Logan. As part of South Logan TOD Implementation, several recommendations are proposed for citywide impact.</p> <p>The proposed Center and Corridor code update to amend SMC Sections 17C.111.230 and 17C.120.220 to align with the goals and recommendations of the South Logan TOD Plan and the City of Spokane Comprehensive Plan.</p> <p>The proposed amendments include replacing the allowed height of 70-feet with 75-feet and reducing the distance of and modifying the slope of required height transitions adjacent to R1 and R2 zones to increase the feasibility of development building to the allowed maximum height allowances.</p> <p>For the full code amendments please visit: https://my.spokanecity.org/projects/south-logan-transit-oriented-development-project/</p>
Fiscal Impact	<p>Approved in current year budget? <input type="checkbox"/> Yes <input type="checkbox"/> No <input checked="" type="checkbox"/> N/A</p> <p>Total Cost: Click or tap here to enter text.</p> <p>Narrative: The South Logan TOD Plan and FEIS, adopted by resolution on January 29, 2024, was funded through the Transit-Oriented Development Implementation (TODI) grant program through the WA Department of Commerce. Implementation of the South Logan TOD Plan relied on on-going and regular staff resources.</p> <p>Funding Source <input type="checkbox"/> One-time <input type="checkbox"/> Recurring <input checked="" type="checkbox"/> N/A</p> <p>Specify funding source: Select Funding Source*</p> <p>Is this funding source sustainable for future years, months, etc? Click or tap here to enter text.</p> <p>Expense Occurrence <input type="checkbox"/> One-time <input type="checkbox"/> Recurring <input checked="" type="checkbox"/> N/A</p> <p>Other budget impacts: (revenue generating, match requirements, etc.)</p>
Operations Impacts (If N/A, please give a brief description as to why)	
<i>What impacts would the proposal have on historically excluded communities?</i>	

The proposed text amendments are intended to support high quality transit, increase housing capacity and diversity, and promote affordability along the City Line bus rapid transit in the South Logan area and throughout Center and Corridor and higher intensity residential areas throughout Spokane. By focusing on development along transit lines and removing identified barriers to successful projects, the proposals are intended to support a diversity of uses and housing options near existing multimodal transportation options.

How will data be collected, analyzed, and reported concerning the effect of the program/policy by racial, ethnic, gender identity, national origin, income level, disability, sexual orientation, or other existing disparities?

The South Logan TOD Plan reviewed and analyzed environmental and social impacts of planned development and development alternatives as part of the process, following the guidance of the HEAL Act. An analysis of existing conditions established a baseline to inform the project with data on demographics, socioeconomics, housing and market conditions, land use and zoning, and infrastructure needs. The proposals are implementing the adopted Plan with no additional data collection.

How will data be collected regarding the effectiveness of this program, policy, or product to ensure it is the right solution?

The South Logan TOD Plan was developed after a 20-month community engagement process that sought input from residents, businesses, institutions, agency partners, and other subject matter experts. The proposals are implementing the recommendations of the adopted Plan. Additional community outreach and engagement occurred after draft ordinances were available to verify effectiveness of the implementation.

Describe how this proposal aligns with current City Policies, including the Comprehensive Plan, Sustainability Action Plan, Capital Improvement Program, Neighborhood Master Plans, Council Resolutions, and others?

The South Logan TOD Project is aligned with many City policies to better connect land use and transportation, expand and increase the housing supply including middle housing and affordable housing, and promote anti-displacement and equitable outcomes. This includes the Comprehensive Plan (Housing Chapter), Housing Action Plan, Sustainability Action Plan, and Transit-Oriented Development Framework Study, and Logan Neighborhood Identity Plan. The proposals are implementing the South Logan TOD Plan, which was adopted by resolution on January 29, 2024 after being determined to meet all relevant policies and plans.

ORDINANCE NO. C36555

AN ORDINANCE relating to height and height transition standards amending Spokane Municipal Code (SMC) Sections 17C.111.230 and 17C.120.220.

WHEREAS, in 2021, the Washington State Legislature appropriated \$2.5 million for cities to facilitate transit-oriented development in areas with light rail or fixed rail systems, bus rapid transit, high-frequency bus service or park and ride lots; and

WHEREAS, the City of Spokane was one of 11 communities that received the Transit-Oriented Development Implementation (TODI) grant for \$250,000 from the Washington Department of Commerce in 2021 to facilitate transit-oriented development and increase residential capacity in areas of high-capacity transit; and

WHEREAS, the City of Spokane prepared the Transit-Oriented Development (TOD) Framework Action Plan, adopted by resolution in May 2022 under RES 2022-0039, that identifies strategies best suited to Spokane for supporting TOD along new High-Performance Transit lines, including a focus on South Logan; and

WHEREAS, the City provided opportunities for meaningful public involvement and review in the South Logan TOD Plan and EIS process, including a community meeting consistent with RCW 43.21C.440; has considered all comments received; and, as appropriate, has modified the proposal or mitigation measures in response to comments, resulting in the Preferred Alternative analyzed in the FEIS; and

WHEREAS, the *Final South Logan TOD Plan and Final Environmental Impact Statement (FEIS)* was published on November 30, 2023 for final consideration; and

WHEREAS, on January 29, 2024 Spokane City Council adopted by resolution (RES 2024-0015) the Final South Logan TOD Plan and FEIS as a declaration of the subarea's desired future condition; and

WHEREAS, in order to facilitate the higher intensity residential development envisioned in the Plan, the adopted Final South Logan TOD Plan called for a review of permitted heights and height transition requirements; and

WHEREAS, based on feedback from developers and the community, it was determined that increased maximum heights may support the feasibility of higher intensity residential development within the South Logan TOD project area; and

WHEREAS, for regulatory consistency throughout Spokane and to ensure the benefits of increased feasibility, the amendments affect citywide development regulations; and

WHEREAS, on April 29, 2024, the Washington State Department of Commerce and appropriate state agencies were given the required 60-day notice of the City's intent to adopt updated development regulations; and

WHEREAS, the Spokane Plan Commission held public workshops on the provisions in this ordinance on March 13, April 10, April 24, May 22, and June 12 of this year; and

WHEREAS, a SEPA Determination of Nonsignificance and Checklist were issued by Planning Services on June 12, 2024; and

WHEREAS, prior to the Plan Commission public hearing, a legal notice was published in the *Spokesman-Review* on June 12 and June 19, 2024; and

WHEREAS, on June 19, 2024, the Planning Department staff finalized their Staff Report to the Spokane Plan Commission recommending approval of the provisions of this ordinance; and

WHEREAS, on June 26, 2024, the Spokane Plan Commission held a public hearing on the provisions of this ordinance and unanimously voted to recommend approval with conditions, as outlined in the Findings of Fact, Conclusions, and Recommendation signed June 28, 2024; and

WHEREAS, the City Council adopts the recitals set forth herein as its findings and conclusions in support of its adoption of this ordinance.

NOW, THEREFORE, the City of Spokane does ordain:

Section 1. That SMC Section 17C.111.230 is amended to read as follows:

17C.111.230 Height

A. Purpose.

The height standards promote a reasonable building scale and relationship of one residence to another and they promote privacy for neighboring properties. The standards contained in this section reflect the general building scale and placement of houses in the City's neighborhoods.

B. Height Standards.

The maximum height standards for all structures are stated in Table 17C.111.205-2. The building height shall be measured using the following method (see Figure 17C.111.230-A):

1. Building height is the vertical distance from the average grade to the highest point of the roof or structure that is not listed as an exception to the maximum building height limits as listed in Section 17C.111.230(C).
2. Underground portions of the structure are not included in height calculations. The height of the structure shall be calculated from the point at which the sides meet the surface of the ground.
3. “Average grade” means the average of the ground level adjoining the building at all exterior walls. Where the ground level slopes away from the exterior walls, the reference point shall be established by the lowest points within the area between the building and the lot line or where the lot line is more than 6 feet from the building, use the reference point between the structure and a point 6 feet from the building.
4. Measurements shall be taken at the existing grade or finished grade, whichever is lower.
5. Depressions such as window wells, stairwells for exits required by other codes, “barrier free” ramps on grade, and vehicle access driveways into garages shall be disregarded in determining structure height when in combination they comprise less than fifty percent of the facade on which they are located. In such cases, the grade for height measurement purposes shall be a line between the grades on either side of the depression.

FIGURE 17C.110.230-A: Height Measurement

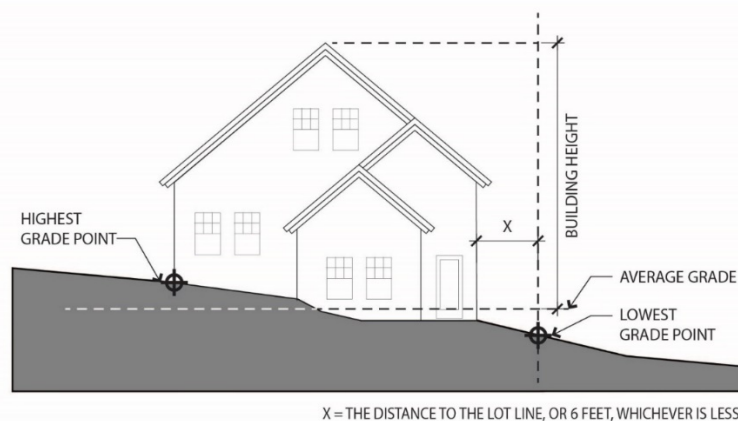

Figure 17C.111.230-A Height Measurement

6. For purposes of measuring building height in residential zones, the following terms shall be interpreted as follows:

- a. "Grade" means the ground surface contour (see also "existing grade" and "finished grade").
- b. "Fill" means material deposited, placed, pushed, pulled or transported to a place other than the place from which it originated.
- c. "Finished grade" means the grade upon completion of the fill or excavation.
- d. "Excavation" means the mechanical removal of earth material.
- e. "Existing grade" means the natural surface contour of a site, including minor adjustments to the surface of the site in preparation for construction.

C. Exceptions to the maximum height standard are stated below:

1. Exceptions to the maximum structure height in the RMF and RHD zones are designated on the official zoning map by a dash and a height listed after the zone map symbol (i.e., RHD-150). Changes to the height limits in the RMF and RHD zones require a rezone. Height limits are forty feet, fifty-five feet, ~~((seventy feet))~~ seventy-five feet, or one hundred fifty feet depending on location.

~~((2. In RMF and RHD zones where the maximum structure height is forty feet, pitched roof structures are allowed an additional fifteen feet above the maximum height standard stated in Table 17C.111.205-2, provided that the roof incorporates all of the following:~~

- ~~a. pitched roof forms having slopes between 4:12 and 12:12; and~~
- ~~b. a minimum of one roof plane that intersects the maximum height plane (see Figure 17C.111.230-B for eligible examples); and~~
- ~~c. establishes sense of "top" per SMC 17C.111.455.))~~

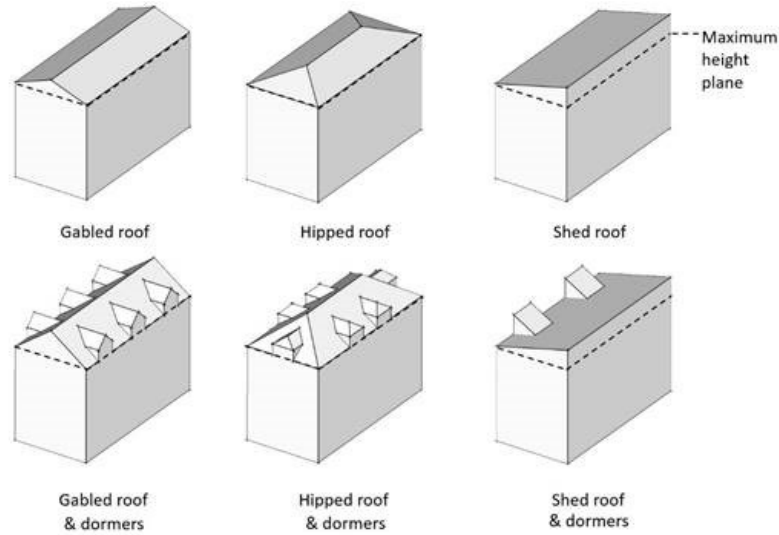

~~((Figure 17C.111.230-B: Roof Type Examples for Height Exception))~~

[NOTE: Delete graphic above]

~~((3))~~2. In the RMF and RHD zones, height does not include up to three feet of the above-grade portions of basement parking, where the elevation of the first residential finished floor is three feet or less above the lowest elevation of the existing grade or finished grade, whichever is lower. See Figure ~~((17C.111.230-C))~~ 17C.111.230-B.

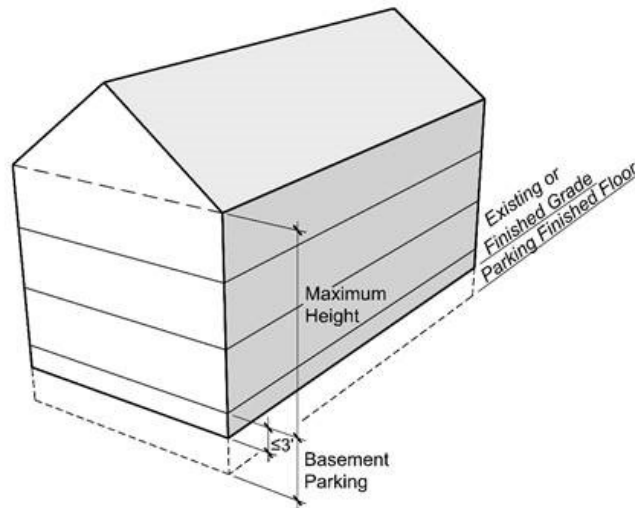

Figure ~~((17C.111.230-C))~~ 17C.111.230-B: Basement Parking Excluded from Height

((4))3. Buildings and structures over fifty feet in height must follow the design, setback and dimensional standards found in [chapter 17C.250 SMC](#), Tall Building Standards

((5))4. Adjacent to R1 and R2 Zones.

To provide a gradual transition and enhance the compatibility between the more intensive commercial zones and adjacent R1 and R2 residential zones:

a. For all development within ~~((one hundred fifty))~~ forty feet of any R1 or R2 residential zone the maximum building height is as follows:

i. Starting at a height of ~~((thirty))~~ forty feet ~~((the residential zone boundary))~~ at R1 and R2 property boundaries, additional building height may be added at a ratio of ~~((one))~~ 2 to ~~((two))~~ 1 ~~((one foot))~~ two feet of additional building height for every ~~((two feet))~~ one foot of additional horizontal distance from the closest ~~((single-family))~~ R1 or ~~((two-family))~~ R2 ~~((residential zone))~~ zoned property. ~~((The building height transition requirement ends one hundred fifty feet from the R1 or R2 residential zone and then full building height allowed in the zone applies.))~~

ii. The building height transition requirement ends forty feet from the R1 or R2 zoned property line and then full building height allowed in the zone applies.

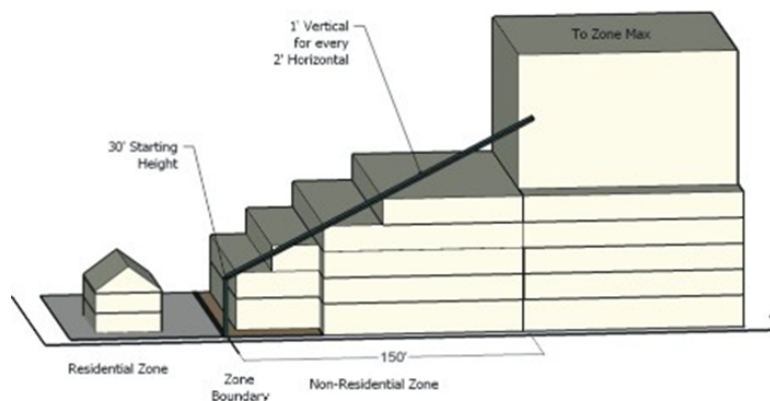

[NOTE: Delete graphic above]

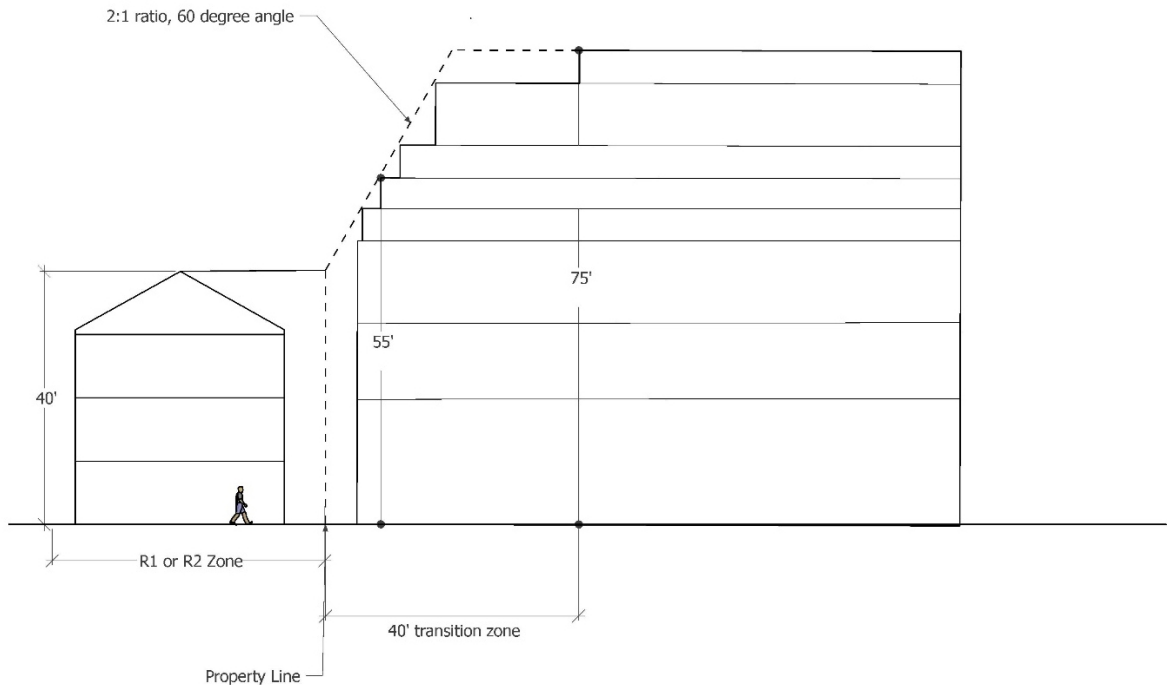

Figure 17C.111.230-C: Height Transition

~~((6. In the RMF zone within forty feet of a common boundary with a R1 zone, the maximum height is forty feet.))~~

~~((7))~~5. Projections Allowed.

Chimneys, flagpoles, satellite receiving dishes and other similar items with a width, depth or diameter of three feet or less may extend above the height limit, as long as they do not exceed three feet above the top of the highest point of the roof. If they are greater than three feet in width, depth or diameter, they are subject to the height limit.

~~((8))~~6. In addition to the projections allowed under subsection (7) above, in the RMF and RHD zones, the following projections above the roof height are allowed:

- a. Parapets and rooftop railings may extend four feet above the height limit.
- b. Walls or fences located between individual rooftop decks may extend six feet above the height limit if the wall or fence is set back at least four feet from the edges of the roof.

- c. Stairway enclosures that provide rooftop access and cumulatively cover no more than ten percent of the roof area may extend up to ten feet above the height limit, provided that the enclosures are setback at least fifteen feet from all roof edges on street facing facades.

~~((9))~~7. Farm Buildings.

Farm buildings such as silos, elevators and barns are exempt from the height limit as long as they are set back from all lot lines at least one foot for every foot in height.

- ~~((10))~~8. Utility power poles and public safety facilities are exempt from the height limit.

- ~~((14))~~9. Radio and television antennas are subject to the height limit of the applicable zoning category.

- ~~((12))~~10. Wireless communication support towers are subject to the height requirements of [chapter 17C.355A SMC](#), Wireless Communication Facilities.

- ~~((13))~~11. Uses approved as a conditional use may have building features such as a steeple or tower which extends above the height limit of the underlying zone. Such building features must set back from the side property line adjoining a lot in a residential zone a distance equal to the height of the building feature or one hundred fifty percent of the height limit of the underlying zone, whichever is lower.

D. Special Height Districts.

Special height districts are established to control structure heights under particular circumstances such as preservation of public view or airport approaches. See [chapter 17C.170 SMC](#), Special Height Overlay Districts.

E. Accessory Structures.

The height of any accessory structure located in the rear yard, including those attached to the primary residence, is limited to twenty feet in height, except a detached ADU above a detached accessory structure may be built to twenty-five (25) feet in height.

Section 2. That SMC Section 17C.120.220 be amended to read as follows:

17C.120.220 Height

A. Purpose

The height limits are intended to control the overall scale of buildings. The height limits in the O, NR and NMU zones discourage buildings that visually dominate adjacent residential areas. The height limits in the OR, CB and GC zones allow for a greater building height at a scale that generally reflects Spokane's commercial areas. Light, air and the potential for privacy are intended to be preserved in single-family residential zones that are close to commercial zones.

B. Height Standards

The height standards for all structures are stated in [Table 17C.120-2](#). Exceptions to the maximum height standard are stated below.

1. Maximum Height.

Exceptions to the maximum structure height are designated on the official zoning map by a dash and a height listed after the zone map symbol (i.e., CB-150). Changes to the height limits require a rezone. Height limits are ~~((thirty-five feet,))~~ forty feet, fifty-five feet, ~~((seventy feet))~~ seventy-five feet, or one hundred fifty feet depending on location.

2. Buildings and structures over fifty feet in height must follow the design, setback and dimensional standards found in [chapter 17C.250 SMC](#), Tall Building Standards.

3. Adjacent to ~~((Single-family))~~ R1 and ~~((Two-family Residential))~~ R2 Zones.

To provide a gradual transition and enhance the compatibility between the more intensive commercial zones and adjacent ~~((single-family))~~ R1 and ~~((two-family))~~ R2 residential zones:

a. For all development within one hundred fifty feet of ~~((any single-family or two-family residential zone))~~ R1 or R2 zoned properties the maximum building height is as follows:

i. Starting at a height of ~~((thirty))~~ forty feet at ~~((the residential zone boundary))~~ R1 and R2 property boundaries, additional building height may be added at a ratio of ~~((4))~~ 2 to ~~((2))~~ 1 ~~((one-foot))~~ two feet of additional building height for every ~~((two feet))~~ one foot of additional horizontal distance from the closest ~~((single-family))~~ R1 or ~~((two-family))~~ R2 ~~((residential zone))~~ zoned property line. ~~((The building height transition~~

requirement ends one hundred fifty feet from the single-family or two-family residential zone and then full building height allowed in the zone applies.))

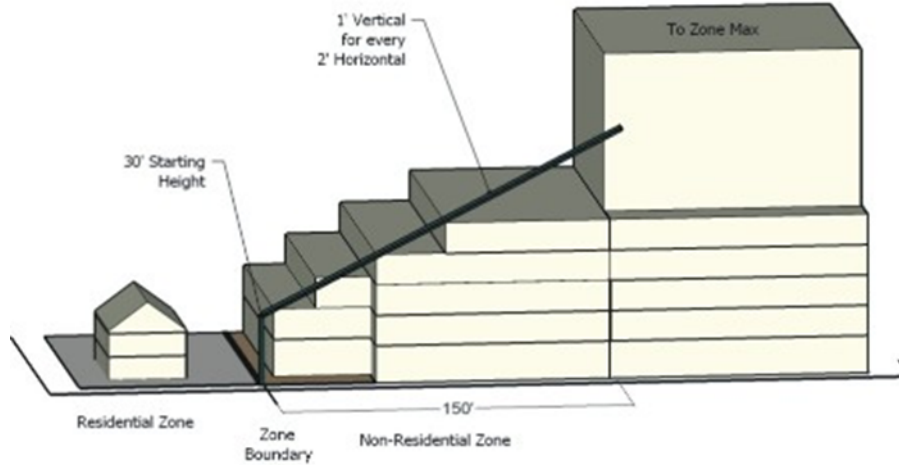

[NOTE: Delete graphic above]

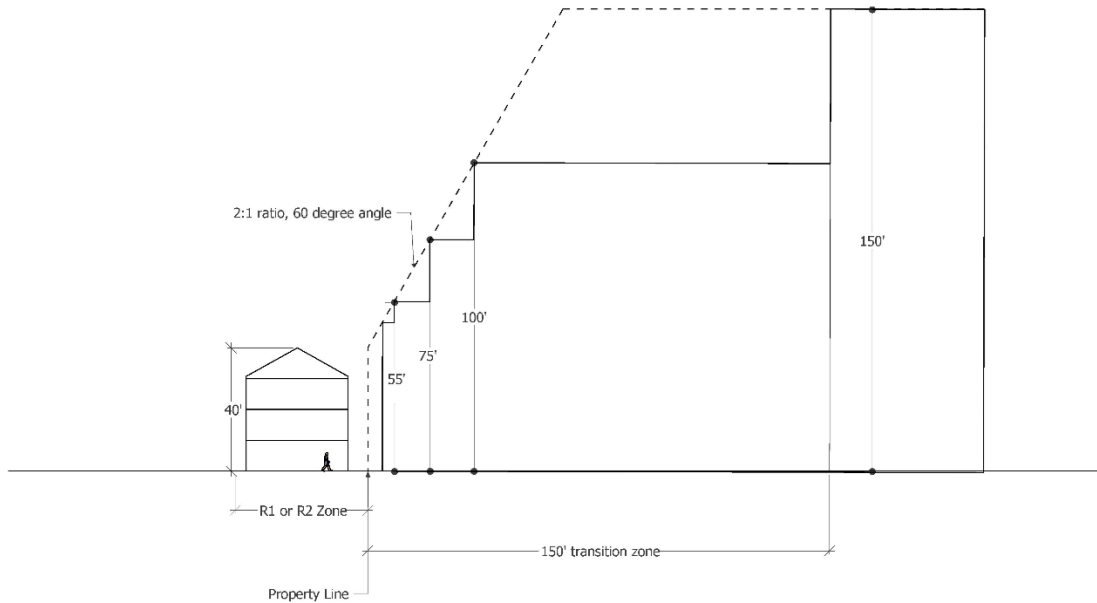

Figure 17C.120.220: Height Transition

4. Projections Allowed.

Chimneys, flag poles, satellite receiving dishes, and other similar items with a width, depth or diameter of five feet or less may rise ten feet above the height limit, or five feet above the highest point of the roof, whichever is greater. If they are greater than five feet in width, depth or diameter, they are subject to the height limit.

5. Rooftop Mechanical Equipment.

All rooftop mechanical equipment must be set back at least fifteen feet from all roof edges that are parallel to street lot lines. Elevator mechanical equipment may extend up to sixteen feet above the height limit. Other rooftop mechanical equipment which cumulatively covers no more than ten percent of the roof area may extend ten feet above the height limit.

6. Radio and television antennas, utility power poles, and public safety facilities are exempt from the height limit except as provided in chapter 17C.355A SMC, Wireless Communication Facilities.

C. Special Height Districts

Special height districts are established to control structure heights under particular circumstances such as preservation of public view or airport approaches. See [chapter 17C.170 SMC](#), Special Height Overlay Districts.

PASSED by the City Council on _____.

Council President

Attest:

Approved as to form:

City Clerk

Assistant City Attorney

Mayor

Date

Effective Date

**CITY OF SPOKANE PLAN COMMISSION
FINDINGS OF FACT, CONCLUSIONS, AND RECOMMENDATIONS
REGARDING HEIGHT AND HEIGHT TRANSITION CODE AMENDMENTS**

A recommendation of the City of Spokane Plan Commission to the City Council to approve amendments to the Spokane Municipal Code proposed height and height transition text amendments. The proposal amends the Unified Development Code (UDC) Sections 17C.111.230 and 17C.120.220 to implement the adopted South Logan Transit-Oriented Development Plan.

FINDINGS OF FACT:

- A. The City of Spokane adopted a Comprehensive Plan in May of 2001 that complies with the requirements of the Growth Management Act (GMA) as set forth in RCW 36.70A.
- B. In 2021, the Washington State Legislature appropriated \$2.5 million for cities to facilitate transit-oriented development planning in areas with light rail or fixed rail systems, bus rapid transit, high frequency bus service or park and ride lots.
- C. The City of Spokane prepared the Transit-Oriented Development (TOD) Framework Action Plan, adopted by resolution in May 2022 under RES 2022-0039, that identifies strategies best suited to Spokane for supporting TOD along new High-Performance Transit lines, including a focus on South Logan.
- D. The City provided opportunities for meaningful public involvement and review in the South Logan TOD Plan and EIS process, including a community meeting consistent with RCW 43.21C.440; has considered all comments received; and, as appropriate, has modified the proposal or mitigation measures in response to comments, resulting in the Preferred Alternative analyzed in the Final Environmental Impact Statement (FEIS).
- E. The *Final South Logan TOD Plan* and *Final Environmental Impact Statement (FEIS)* were published on November 30, 2023 for final consideration.
- F. On January 29, 2024 Spokane City Council adopted by resolution (RES 2024-0015) the Final South Logan TOD Plan and FEIS as a declaration of the subarea's desired future condition.
- G. In order to facilitate the higher intensity residential development envisioned in the Plan, the adopted Final South Logan TOD Plan called for a review of permitted heights and height transition requirements. For regulatory consistency throughout Spokane and to ensure the benefits of increased feasibility, the amendments are proposed to affect citywide development regulations.
- H. The draft amendments relied on the 20-month planning process and extensive public engagement that occurred as part of the development of the South Logan TOD Plan. Outreach and public communication specifically about South Logan TOD Implementation began in February 2024 and included the following among others:
 - 1. Logan Neighborhood Council meeting presentation on February 13, 2024;

Findings of Fact, Conclusion, and Recommendation

2. Plan Commission Workshops on March 13, April 10, April 24, May 8, May 22, and June 12, 2024;
 3. Various community tabling events on March 19, April 9, and May 18, 2024;
 4. A virtual information session on April 30, 2024;
 5. Coffee Chat pop-up events on May 4, May 23, and June 1, 2024;
 6. Regular South Logan TOD newsletter and webpage updates, as well as City of Spokane newsletter and social media posts.
- I. Public comment, as well as agency and department comments, received prior to the June 26, 2024, Plan Commission public hearing were included in the staff report.
 - J. On March 13, April 10, April 24, May 8, May 22, and June 12, 2024, the Spokane Plan Commission held workshops to discuss draft language, receive updates on public feedback as well as city department and agency comments, and review and evaluate with city staff alternatives to proposed text changes.
 - K. On April 29, 2024, the Washington State Department of Commerce and appropriate state agencies were given the required 60-day notice of the City's intent to adopt updated development regulations pursuant to RCW 36.70A.106.
 - L. On April 29, 2024, a Notice of Intent to Adopt and Request for SEPA agency comments was issued for the draft code pertaining to the proposed South Logan TOD Implementation text amendments. The comment period ended on May 13, 2024. No comments were received.
 - M. The SEPA Determination of Nonsignificance and Checklist were issued by Planning Services on June 12, 2024. The comment period ended on June 26, 2024. No comments were received.
 - N. Prior to the Plan Commission public hearing, a legal notice was published in the *Spokesman-Review* on June 12 and June 19, 2024; and
 - O. The proposed text amendments were drafted and reviewed pursuant to the process established under RCW 36.70A.370 to ensure that the proposed changes will not result in unconstitutional takings of private property.
 - P. Amendments to Title 17 are subject to review and recommendation by the Plan Commission.

Findings of Fact, Conclusion, and Recommendation

- Q. On June 26, 2024, the Spokane Plan Commission held a public hearing on the proposed text amendments, including the taking of verbal testimony, and closed the public record on that date.
- R. Public comment, as well as agency and department comments, received prior to the June 26, 2024 Plan Commission public hearing were included in the staff report.
- S. During deliberations held on June 26, 2024, the Plan Commission discussed the concerns expressed in public comments and testimony about public safety within the South Logan Subarea.
- T. Except as otherwise indicated in the above findings, the Spokane Plan Commission adopts the findings and analysis set forth in the staff report prepared for the proposal.
- U. The Spokane Plan Commission finds that the proposed text amendments meet the decision criteria established in SMC 17G.025.010(G).

CONCLUSIONS:

Based upon the draft text amendments, staff report and analysis (which is hereby incorporated into these findings, conclusions, and recommendations), SEPA review, agency and public comments received, and public testimony presented, the Spokane Plan Commission makes the following conclusions with respect to the text amendments to the Hamilton Form-Based Code:

1. The Plan Commission finds that the proposed amendments bear a substantial relation to the public health, safety, welfare, and protection of the environment pursuant to the requirements outlined in SMC 17G.025.010(G).
2. The proposed text amendments will implement the goals and policies of the Comprehensive Plan.
3. The proposed text amendments will implement the adopted South Logan Transit-Oriented Development Plan.
4. Interested agencies and the public have had extensive opportunities to participate throughout the process and persons desiring to comment were given an opportunity to comment.
5. SEPA review was completed for the proposal, and pursuant to SEPA, any adverse environmental impacts associated with the proposed regulations will be mitigated by enforcement of the City's development regulations.
6. Plan Commission concludes that the intent of the including neighborhood councils to the list of entities that receive notice of applications was to give neighborhood councils standing and the ability to advocate for their neighborhood residents. As entities of standing, neighborhood councils should assume the responsibility of proactively communicated with their residents about pertinent all-city or neighborhood-specific development applications.

7. The Plan Commission finds that the proposed amendments are consistent with the applicable provisions of the Comprehensive Plan, particularly the following adopted goals and policies:
 - a. Chapter 3: Land Use – Goal 1 – Citywide Land Use, Policy LU 1.4 Higher Intensity Residential Areas
 - b. Chapter 3: Land Use – Goal 3 – Efficient Land Use, Policy LU 3.1 Coordinated and Efficient Land Use
 - c. Chapter 3: Land Use – Goal 3 – Efficient Land Use, Policy LU 3.2 Centers and Corridors
 - d. Chapter 3: Land Use – Goal 3 – Efficient Land Use, Policy 3.5 Mix of Uses in Centers
 - e. Chapter 3: Land Use – Goal 4 – Transportation, Policy LU 4.1 Land Use and Transportation
 - f. Chapter 3: Land Use – Goal 4 – Transportation, Policy LU 4.6 Transit-Supported Development
 - g. Chapter 3: Land Use – Goal 5 – Development Character, Policy LU 5.1 Built and Natural Environment
 - h. Chapter 3: Land Use – Goal 5 – Development Character, Policy LU 5.5 Complementary Development
 - i. Chapter 6: Housing – Goal H1 – Housing Choice and Diversity, Policy H 1.4 Use of Existing Infrastructure
 - j. Chapter 6: Housing – Goal H1 – Housing Choice and Diversity, Policy H 1.7 Socioeconomic Integration
 - k. Chapter 6: Housing – Goal H1 – Housing Choice and Diversity, Policy H 1.11 Access to Transportation
 - l. Chapter 8: Urban Design and Historic Presentation – Goal DP 1 – Price and Identity, Policy DP 1.2 New Development in Established Neighborhoods
 - m. Chapter 8: Urban Design and Historic Preservation – Goal DP 2 – Urban Design, Policy DP 2.2 Design Guidelines and Regulations
 - n. Chapter 8: Urban Design and Historic Preservation – Goal DP 2 – Urban Design, Policy DP 2.6 Building and Site Design
 - o. Chapter 8: Urban Design and Historic Preservation – Goal DP 2 – Urban Design, Policy DP 2.7 Historic District and Sub-Area Design Guidelines
 - p. Chapter 8: Urban Design and Historic Preservation – Goal DP 2 – Urban Design, Policy DP 2.12 Infill Development
 - q. Chapter 8: Urban Design and Historic Preservation – Goal DP 2 – Urban Design, Policy 2.13 Parking Facilities Design

- r. Chapter 11: Neighborhoods – Goal N 4 – Traffic Circulation, Policy N 4.7 Pedestrian Design
8. The Plan Commission recognizes the concerns expressed by community members about public safety within the South Logan Subarea. While the Plan Commission urges continued community collaboration with public safety and code enforcement officials, the body recognizes the positive impact that transit-oriented and pedestrian-oriented development can have on public safety within the built environment. Increased density and mix of uses made possible with amendments to the Center and Corridor zones, higher intensity residential zones, and height allowances, as well as street activation as called for in the Hamilton Form-Based Code, encourage more eyes on the street and have been found to have a positive effect on safety and walkability.

RECOMMENDATION:

In the matter of the ordinance pertaining to the Hamilton Form-Based Code, amending the Unified Development Code of the City of Spokane:

1. By a vote of seven to zero, the City of Spokane Plan Commission recommends to the Spokane City Council the **APPROVAL** of the proposed amendments to Sections 17C.111.230 and 17C.120.220.
2. The City of Spokane Plan Commission authorizes the Plan Commission President to prepare and sign on the Commission's behalf a written decision setting forth the Plan Commission's findings, conclusions, and recommendations on the proposed amendments.

Greg Francis

[Greg Francis \(Jun 27, 2024 17:44 PDT\)](#)

Greg Francis, President

Spokane Plan Commission

Jun 27, 2024

Click or tap to enter a date.

PC Findings and Conclusions_ Height and Height Transition

Final Audit Report

2024-06-28

Created:	2024-06-27
By:	AMANDA KIEHN (AKIEHN@SPOKANECITY.ORG)
Status:	Signed
Transaction ID:	CBJCHBCAABAADdKvG6ENsZmVnLETjYe-u1avsEUhEYsw

"PC Findings and Conclusions_ Height and Height Transition" History

 Document created by AMANDA KIEHN (AKIEHN@SPOKANECITY.ORG)

2024-06-27 - 10:05:03 PM GMT

 Document emailed to gfrancis@spokanecity.org for signature

2024-06-27 - 10:05:32 PM GMT

 Email viewed by gfrancis@spokanecity.org

2024-06-28 - 0:43:47 AM GMT

 Signer gfrancis@spokanecity.org entered name at signing as Greg Francis

2024-06-28 - 0:44:02 AM GMT

 Document e-signed by Greg Francis (gfrancis@spokanecity.org)

Signature Date: 2024-06-28 - 0:44:04 AM GMT - Time Source: server

 Agreement completed.

2024-06-28 - 0:44:04 AM GMT

**Agenda Sheet for City Council:****Committee:** Urban Experience **Date:** 07/08/2024**Committee Agenda type:** Discussion**Date Rec'd**

7/8/2024

Clerk's File #

ORD C36556

Cross Ref #**Project #****Council Meeting Date:** 07/22/2024**Submitting Dept**

PLANNING & ECONOMIC

Bid #**Contact Name/Phone**

KAYCEE X6194

Requisition #**Contact E-Mail**

KDOWNNEY@SPOKANECITY.ORG

Agenda Item Type

First Reading Ordinance

Council Sponsor(s)

ZZAPPONE JBINGLE KKLITZKE

Agenda Item Name

0650 - CENTER AND CORRIDOR CODE UPDATE ASSOCIATED WITH SOUTH

Agenda Wording

Center and Corridor code update to SMC Sections 17C.122.070, 17C.122.090, 17C.230.120, 17C.230.130, 17C.300.130, 17C.122.080, 17C.122.100, 17C.122.110, 17C.122T, 17C.122.200, 17C.122.210, 17C.122.220, 17C.122.230, 17C.122.240, and 17C.122.250

Summary (Background)

The South Logan Transit-Oriented Development (TOD) Plan, adopted by resolution on January 29, 2024, provides recommendations to support more connectivity and livability for the community, businesses, and organization in South Logan. As part of South Logan TOD Implementation, several recommendations are proposed for citywide impact. The proposed Center and Corridor code update to amend SMC Sections 17C.122.070, 17C.122.090, 17C.230.120, 17C.230.130, and 17C.300.130, repeal Sections 17C.122.080

Lease? NO

Grant related? NO

Public Works? NO

Fiscal Impact

Approved in Current Year Budget? N/A

Total Cost

\$

Current Year Cost

\$

Subsequent Year(s) Cost

\$

Narrative

The S. Logan TOD Plan and FEIS, adopted by resolution on January 29, 2024, was funded through the TOD Implementation grant program via the WA Department of Commerce. Implementation of the S. Logan TOD Plan relied on on-going and regular staff resources.

Amount**Budget Account**

Neutral

\$

#

Select

\$

#

Select

\$

#

Select

\$

#

Select

\$

#

Select

\$

#



Continuation of Wording, Summary, Approvals, and Distribution

Agenda Wording

for South Logan TOD Implementation.

Summary (Background)

17C.122.100, 17C.122.110, and 17C.122T, and adopt Sections 17C.122.200, 17C.122.210, 17C.122.220, 17C.122.230, 17C.122.240, and 17C.122.250 includes removing parking minimums for Center and Corridor and Downtown zones and revising development regulations to support transit-oriented development.

Approvals

<u>Dept Head</u>	GARDNER, SPENCER
<u>Division Director</u>	MACDONALD, STEVEN
<u>Accounting Manager</u>	ORLOB, KIMBERLY
<u>Legal</u>	SCHOEDEL, ELIZABETH
<u>For the Mayor</u>	JONES, GARRETT

Additional Approvals

Distribution List

kdowney@spokanecity.org	sgardner@spokanecity.org
tblack@spokanecity.org	tkimbrell@spokanecity.org
smacdonald@spokanecity.org	amccall@spokanecity.org

Committee Agenda Sheet

Urban Experience Committee

Committee Date	July 8, 2024
Submitting Department	Planning & Economic Development
Contact Name	KayCee Downey
Contact Email & Phone	kdowney@spokanecity.org , x6194
Council Sponsor(s)	<u>CM Zappone, CM Bingle, CM Klitzke</u>
Select Agenda Item Type	<input type="checkbox"/> Consent <input checked="" type="checkbox"/> Discussion Time Requested: 5 minutes
Agenda Item Name	Center and Corridor Code Update Associated with South Logan TOD Implementation
Proposed Council Action	<input checked="" type="checkbox"/> Approval to proceed to Legislative Agenda <input type="checkbox"/> Information Only
Summary (Background) *use the Fiscal Impact box below for relevant financial information	<p>The South Logan Transit-Oriented Development (TOD) Plan, adopted by resolution on January 29, 2024, provides recommendations to support more connectivity and livability for the community, businesses, and organization in South Logan. As part of South Logan TOD Implementation, several recommendations are proposed for citywide impact.</p> <p>The proposed Center and Corridor code update to amend SMC Sections 17C.122.070, 17C.122.090, 17C.230.120, 17C.230.130, and 17C.300.130, repeal Sections 17C.122.080, 17C.122.100, 17C.122.110, and 17C.122T, and adopt new Sections 17C.122.200, 17C.122.210, 17C.122.220, 17C.122.230, 17C.122.240, and 17C.122.250 align with the goals and recommendations of the South Logan TOD Plan and the City of Spokane Comprehensive Plan.</p> <p>The proposed amendments include modifying height standards and drive-thru allowances, removing parking minimums for Center and Corridor and Downtown zones, and revising other development regulations to support transit-oriented development.</p> <p>For the full code amendments please visit: https://my.spokanecity.org/projects/south-logan-transit-oriented-development-project/</p>
Fiscal Impact	<p>Approved in current year budget? <input type="checkbox"/> Yes <input type="checkbox"/> No <input checked="" type="checkbox"/> N/A</p> <p>Total Cost: Click or tap here to enter text.</p> <p>Narrative: The South Logan TOD Plan and FEIS, adopted by resolution on January 29, 2024, was funded through the Transit-Oriented Development Implementation (TODI) grant program through the WA Department of Commerce. Implementation of the South Logan TOD Plan relied on on-going and regular staff resources.</p> <p>Funding Source <input type="checkbox"/> One-time <input type="checkbox"/> Recurring <input checked="" type="checkbox"/> N/A</p> <p>Specify funding source: Select Funding Source*</p> <p>Is this funding source sustainable for future years, months, etc? Click or tap here to enter text.</p> <p>Expense Occurrence <input type="checkbox"/> One-time <input type="checkbox"/> Recurring <input checked="" type="checkbox"/> N/A</p> <p>Other budget impacts: (revenue generating, match requirements, etc.)</p>

Operations Impacts (If N/A, please give a brief description as to why)

What impacts would the proposal have on historically excluded communities?

The proposed text amendments are intended to support high quality transit, increase housing capacity and diversity, and promote affordability along the City Line bus rapid transit in the South Logan area and throughout Center and Corridor and higher intensity residential areas throughout Spokane. By focusing on development along transit lines and removing identified barriers to successful projects, the proposals are intended to support a diversity of uses and housing options near existing multimodal transportation options.

How will data be collected, analyzed, and reported concerning the effect of the program/policy by racial, ethnic, gender identity, national origin, income level, disability, sexual orientation, or other existing disparities?

The South Logan TOD Plan reviewed and analyzed environmental and social impacts of planned development and development alternatives as part of the process, following the guidance of the HEAL Act. An analysis of existing conditions established a baseline to inform the project with data on demographics, socioeconomics, housing and market conditions, land use and zoning, and infrastructure needs. The proposals are implementing the adopted Plan with no additional data collection.

How will data be collected regarding the effectiveness of this program, policy, or product to ensure it is the right solution?

The South Logan TOD Plan was developed after a 20-month community engagement process that sought input from residents, businesses, institutions, agency partners, and other subject matter experts. The proposals are implementing the recommendations of the adopted Plan. Additional community outreach and engagement occurred after draft ordinances were available to verify effectiveness of the implementation.

Describe how this proposal aligns with current City Policies, including the Comprehensive Plan, Sustainability Action Plan, Capital Improvement Program, Neighborhood Master Plans, Council Resolutions, and others?

The South Logan TOD Project is aligned with many City policies to better connect land use and transportation, expand and increase the housing supply including middle housing and affordable housing, and promote anti-displacement and equitable outcomes. This includes the Comprehensive Plan (Housing Chapter), Housing Action Plan, Sustainability Action Plan, and Transit-Oriented Development Framework Study, and Logan Neighborhood Identity Plan. The proposals are implementing the South Logan TOD Plan, which was adopted by resolution on January 29, 2024 after being determined to meet all relevant policies and plans.

ORDINANCE NO. C36556

AN ORDINANCE relating to the Center and Corridor and parking development regulations amending Spokane Municipal Code (SMC) Sections 17C.122.070, 17C.122.090, 17C.230.120, 17C.230.130, and 17C.300.130, repealing Sections 17C.122.080, 17C.122.100, 17C.122.110, and 17C.122T, and adopting new Sections 17C.122.200, 17C.122.210, 17C.122.220, 17C.122.230, 17C.122.240, and 17C.122.250.

WHEREAS, in 2021, the Washington State Legislature appropriated \$2.5 million for cities to facilitate transit-oriented development in areas with light rail or fixed rail systems, bus rapid transit, high-frequency bus service or park and ride lots; and

WHEREAS, the City of Spokane was one of 11 communities that received the Transit-Oriented Development Implementation (TODI) grant for \$250,000 from the Washington Department of Commerce in 2021 to facilitate transit-oriented development and increase residential capacity in areas of high-capacity transit; and

WHEREAS, the City of Spokane prepared the Transit-Oriented Development (TOD) Framework Action Plan, adopted by resolution in May 2022 under RES 2022-0039, that identifies strategies best suited to Spokane for supporting TOD along new High-Performance Transit lines, including a focus on South Logan; and

WHEREAS, the City provided opportunities for meaningful public involvement and review in the South Logan TOD Plan and EIS process, including a community meeting consistent with RCW 43.21C.440; has considered all comments received; and, as appropriate, has modified the proposal or mitigation measures in response to comments, resulting in the Preferred Alternative analyzed in the FEIS; and

WHEREAS, the *Final South Logan TOD Plan and Final Environmental Impact Statement (FEIS)* was published on November 30, 2023 for final consideration; and

WHEREAS, on January 29, 2024 Spokane City Council adopted by resolution (RES 2024-0015) the Final South Logan TOD Plan and FEIS as a declaration of the subarea's desired future condition; and

WHEREAS, in order to facilitate the envisioned future development in the Plan, the adopted Final South Logan TOD Plan assumed interim Center and Corridor development regulations would be made permanent; and

WHEREAS, City Council adopted interim development regulations under ORDINANCE NO. C36232 on July 18, 2022, including Section 17C.400.040 Pilot Center and Corridors Development Standards; and

WHEREAS, City Council extended the interim Center and Corridor development regulations under Section 17C.400.040 on November 20, 2023; and

WHEREAS, the interim Center and Corridor development regulations under Section 17C.400.040 expired on June 28, 2024; and

WHEREAS, an ongoing Center and Corridor Study further informed proposed adjustments to the Center and Corridor development regulations to support increase feasibility of transit-supportive and pedestrian-oriented development; and

WHEREAS, for regulatory consistency throughout Spokane and to ensure the benefits of increased feasibility, the amendments affect citywide development regulations; and

WHEREAS, on April 29, 2024, the Washington State Department of Commerce and appropriate state agencies were given the required 60-day notice of the City's intent to adopt updated development regulations; and

WHEREAS, the Spokane Plan Commission held public workshops on the provisions in this ordinance on March 13, April 10, April 24, May 22, and June 12 of this year; and

WHEREAS, a SEPA Determination of Nonsignificance and Checklist were issued by Planning Services on June 12, 2024; and

WHEREAS, prior to the Plan Commission public hearing, a legal notice was published in the *Spokesman-Review* on June 12 and June 19, 2024; and

WHEREAS, on June 19, 2024, the Planning Department staff finalized their Staff Report to the Spokane Plan Commission recommending approval of the provisions of this ordinance; and

WHEREAS, on June 26, 2024, the Spokane Plan Commission held a public hearing on the provisions of this ordinance and unanimously voted to recommend approval with conditions, as outlined in the Findings of Fact, Conclusions, and Recommendation signed June 28, 2024; and

WHEREAS, prior to adopting its Findings of Fact, Conclusions, and Recommendation on June 28, 2024, the Spokane Plan Commission considered, but did not adopt, a recommendation to abolish minimum parking requirements within commercial areas; and

WHEREAS, with due regard for the recommendation of the Spokane Plan Commission, the City Council finds that it is appropriate to abolish minimum parking requirements within commercial areas; and to make permanent the intended effect of Ordinance C36405, adopted July 17, 2023, by fully exempting all residential development from minimum parking requirements; and

WHEREAS, the City Council adopts the recitals set forth herein as its findings and conclusions in support of its adoption of this ordinance.

Section 1. That SMC Section 17C.122.070 Center and Corridor Zone Allowed Uses is amended to read as follows:

Section 17C.122.070 Center and Corridor Zone Allowed Uses

((The uses allowed in the center and corridor zones are shown in Chapter 17C.122T Center and Corridor Zone Development Tables: Table 17C.122.070-1 Center and Corridor Zone Allowed Uses.))

The uses allowed in the Center and Corridor zones are shown in Table 17C.122.070-1.

TABLE 17C.122.070-1 CENTER AND CORRIDOR ZONE ALLOWED USES			
Use is: P – Permitted N – Not Permitted L – Allowed, but special limitations CU – Conditional use review required	CC Zone Type		
	Core Zones	Transition Zone	
	CC1	CC2	CC4
<u>Residential</u>	<u>P</u>	<u>P</u>	<u>P</u>
<u>Hotels, including Bed and Breakfast Inns</u>	<u>P</u>	<u>P</u>	<u>N</u>
<u>Commercial, Financial, Retail, Personal Services</u>	<u>P[1]</u>	<u>P[1]</u>	<u>L[4]</u>
<u>Eating and Drinking Establishments</u>	<u>P[2]</u>	<u>P[2]</u>	<u>N</u>
<u>Restaurants without Cocktail Lounges</u>	<u>P</u>	<u>P</u>	<u>L[4]</u>
<u>Professional and Medical Offices</u>	<u>P</u>	<u>P</u>	<u>L[4]</u>
<u>Entertainment, Museum and Cultural</u>	<u>P</u>	<u>P</u>	<u>N</u>
<u>Government, Public Service or Utility Structures, Social Services and Education</u>	<u>P</u>	<u>P</u>	<u>P</u>
<u>Religious Institutions</u>	<u>P</u>	<u>P</u>	<u>P</u>
<u>Parks and Open Space</u>	<u>P</u>	<u>P</u>	<u>P</u>
<u>Surface Lot Commercial Parking</u>	<u>N</u>	<u>N</u>	<u>N</u>
<u>Structured Commercial Parking*</u>	<u>P</u>	<u>P</u>	<u>P</u>
<u>Public Parking Lot</u>	<u>P</u>	<u>P</u>	<u>N</u>
<u>Limited Industrial (if entirely within a building)</u>	<u>P[3]</u>	<u>P[3]</u>	<u>N</u>
<u>Heavy Industrial</u>	<u>N</u>	<u>N</u>	<u>N</u>
<u>Drive-through Businesses</u>	<u>N</u>	<u>P[5]</u>	<u>P[5]</u>
<u>Motor Vehicles Sales, Rental, Repair or Washing</u>	<u>N</u>	<u>P</u>	<u>N</u>
<u>Automotive Parts and Tires (with exterior storage or display)</u>	<u>N</u>	<u>P</u>	<u>N</u>
<u>Gasoline Sales (serving more than six vehicles)</u>	<u>N</u>	<u>P</u>	<u>N</u>
<u>Gasoline Sale (serving six vehicles or less)</u>	<u>P</u>	<u>P</u>	<u>P</u>
<u>Self-storage or Warehouse</u>	<u>N</u>	<u>P</u>	<u>N</u>
<u>Adult Business (subject to chapter 17C.305 SMC special provisions)</u>	<u>N</u>	<u>N</u>	<u>N</u>
<u>Winery and Microbreweries</u>	<u>P</u>	<u>P</u>	<u>N</u>

Mobile Food Vending	P[6]	P[6]	P[6]
<p><u>Notes:</u></p> <p>[1] <u>Retail uses having more than forty thousand gross floor area are not permitted in neighborhood centers designated by the comprehensive plan.</u></p> <p>[2] <u>Eating and drinking establishments larger than five thousand gross floor area are not permitted in neighborhood centers designated by the comprehensive plan.</u></p> <p>[3] <u>Limited industrial uses having more than twenty thousand gross floor area are not permitted in neighborhood centers designated by the comprehensive plan.</u></p> <p>[4] <u>Residential uses are required to be mixed on the same parcel as proposed office and retail uses. Nonresidential uses are limited to three thousand square feet per parcel. In neighborhood centers, nonresidential uses are only allowed on parcels with frontage on an arterial street. Nonresidential uses in the CC4 zone are not allowed within sixty feet of a single-family and two-family residential zone or further than three hundred feet (neighborhood center only) from a CC core comprehensive plan designation.</u></p> <p>[5] <u>Drive-through businesses are not permitted along designated Pedestrian Streets</u></p> <p>[6] <u>All mobile food vendors shall have a valid mobile food vending license issued pursuant to SMC 10.51.010.</u></p>			

Section 2. That SMC Section 17C.122.080 Floor Area Ratio (FAR) is repealed.

Section 3. That SMC Section 17C.122.090 is amended to read as follows:

Section 17C.122.090 Public Amenities Allowing Bonus ((FAR)) Height

~~((A.—Minor Amenities.~~

~~Each public amenity from the following list may allow an increase of two-tenths FAR from the basic allowable FAR to the maximum FAR.~~

~~1.—Additional Streetscape Features.~~

~~Seating, trees, pedestrian-scaled lighting and special paving in addition to any that are required by the design standards and guidelines.~~

~~2.—Canopy Over the Public Sidewalk.~~

~~A virtually continuous canopy structure. A canopy is a permanent architectural element projecting out from a building facade over a sidewalk or walkway. A canopy shall be at least five feet in horizontal width and be no less than eight feet and no more than twelve feet above grade.~~

~~3.—Alley Enhancements.~~

~~Decorative paving, pedestrian-scaled lighting, special paving and rear entrances intended to encourage pedestrian use of the alley.~~

~~4.—Preferred Materials on Building.~~

~~Use of brick and stone on the building facades that face streets.~~

~~5. An amenity specifically identified and described in an adopted neighborhood plan.~~

~~6. Building to the Street.~~

~~Buildings complying with the “Buildings Along the Street” design guidelines (page 4 of the center and corridor design guidelines) so that at least fifteen percent of the frontage of the site consists of building facades.~~

~~B. Major Amenities.~~

~~Each public amenity from the following list may allow an increase of five-tenths FAR from the basic allowable FAR to the maximum FAR.~~

~~1. Exterior Public Space(s).~~

~~A plaza or courtyard, with a minimum area of four hundred square feet or two percent of the total interior floor space of the development, whichever is greater. A plaza or a courtyard is a level space accessible to the public, at least ten feet in width, with a building façade on at least one side. The elevation of the courtyard or plaza shall be within thirty inches of the grade of the sidewalk providing access to it. For courtyards, at least sixty percent of the green shall be planted with trees, ground cover and other vegetation. For plazas, at least fifteen percent, but no more than sixty percent of the space shall be planted with trees, ground cover and other vegetation. Courtyards and plazas shall also include seating, pedestrian-scale lighting, decorative paving and other pedestrian furnishings. The use of artists to create fixtures and furnishings is strongly encouraged.~~

~~2. Public Art.~~

~~Public art includes sculptures, murals, inlays, mosaics and other two-dimensional or three-dimensional works, as well as elements integrated into the design of a project (e.g, fountain) that are designed and crafted by one or more artists. Such artists must be listed on a registry of either the Washington state arts commission or the Spokane arts commission. To receive the FAR bonus, public art must be documented at a value that is at least one percent of the value of construction.~~

~~3. Through block pedestrian connection providing a continuous walkway accessible to the public, at least ten feet in width, paved with decorative paving and lighted for nighttime use. It may be covered or open to the sky.~~

~~4. Residential Units.~~

~~Comprising at least twenty-five percent of the total floor area.~~

~~5. Structured parking.~~

~~6. If all of the standards and guidelines for Type 1 centers and pedestrian streets are incorporated into a project that is within a Type 2 center.~~

C. ~~“Super Bonuses.”~~

~~Any development that receives super bonuses shall also provide at least two of the major or minor amenities listed above. In return for providing either of the following, the maximum FAR’s may be increased by fifty percent.~~

~~1. Underground Parking.~~

~~All of the parking is provided within a structure that is entirely below grade.~~

~~2. Affordable Housing.~~

~~At least twenty percent of the units are set aside for households making less than eighty percent of the median income for the City as defined by HUD.)~~

A. Development that meets the following conditions may be allowed an additional fifteen feet of height to the maximum height standards in Section 17C.122.200 Development Standards Table.

1. Underground Parking.

a. All off-street parking provided on the site meets one of the following conditions:

i. Parking areas are entirely below the grade of any adjacent streets; or

ii. Surface parking or structured parking at ground level is located entirely behind buildings relative to all adjacent streets; or

iii. Structured parking visible from the street is above ground level with non-parking uses lining the street.

2. Affordable Housing.

a. At least twenty percent of the residential units are set aside for households making less than eighty percent of the Spokane County Area Median Income as defined by the United States Department of Housing and Urban Development.

3. Public Art.

a. May include sculptures, murals, inlays, mosaics, and other two-dimensional or three-dimensional works, as well as elements integrated into the design of a project (e.g., fountain) that are designed and crafted for the aesthetic improvement of the pedestrian realm.

i. To receive the height bonus, public art must be documented at a value that is at least one percent of the value of construction.

Section 4. That SMC Section 17C.122.100 Maximum Building Height is repealed.

Section 5. That SMC Section 17C.122.110 Setbacks and Required Sidewalk Width is repealed.

Section 6. That there is adopted a new Section 17C.122.200 to Chapter 17C.122 SMC to read as follows:

Section 17C.122.200 Development Standards Table

Development standards that apply within Center and Corridor Zones are provided in Table 17C.122.200-2 Center and Corridor Development Standards

Table 17C.122.200-2 Center and Corridor Development Standards				
HEIGHT STANDARDS				
		CC1	CC2	CC4
Neighborhood Center		55 ft [1][2]	55ft [1][2]	55ft [1][2]
District Center or Corridor		75 ft [1][2]	75 ft [1][2]	55 ft [1][2]
Employment Center		150 ft [2]	150 ft [2]	75 ft [2]
FLOOR AREA RATIO (FAR) STANDARDS				
		CC1	CC2	CC4
Neighborhood Center	Minimum FAR	No Minimum	No Minimum	No Minimum
	Maximum FAR	No Maximum	No Maximum	No Maximum
District Center	Minimum FAR	0.5	0.5	0.5
	Maximum FAR	No Maximum	No Maximum	No Maximum
Employment Center	Minimum FAR	1	1	1
	Maximum FAR	No Maximum	No Maximum	No Maximum
SETBACK STANDARDS				
		CC1	CC2	CC4
Minimum setback from street lot line		0 ft.	0 ft.	0 ft.
Minimum setback from R1 and R2 zoned lots		10 ft. [3]	10 ft. [3]	10 ft. [3]
Minimum setback from all zones except R1 and R2		0 ft. [3]	0 ft. [3]	0 ft. [3]
LOT DIMENSIONS				
		CC1	CC2	CC4

Minimum front lot line width	10 ft.	10 ft.	10 ft.
<p>[1] An additional fifteen ft of height is permitted provided that at least one condition under Section 17C.122.090 Public Amenities Allowing Additional Height is met.</p> <p>[2] Structures over seventy feet in height must follow the standards in Chapter 17C.250 Tall Building Standards.</p> <p>[3] Structure setbacks are measured from the lot line.</p>			

Section 7. That there is adopted a new Section 17C.122.210 to Chapter 17C.122 SMC to read as follows:

Section 17C.122.210 Height

A. Height.

The maximum height standards for all structures are stated in Table 17C.122.200-2. The building height shall be measured using the following method (see Figure 17C.122.210-A):

1. Building height is the vertical distance from the average grade to the highest point of the roof or structure.
2. Underground portions of the structure are not included in height calculations. The height of the structure shall be calculated from the point at which the sides meet the surface of the ground.
3. “Average grade” means the average of the ground level adjoining the building at all exterior walls. Where the ground level slopes away from the exterior walls, the reference point shall be established by the lowest points within the area between the building and the lot line or where the lot line is more than 6 feet from the building, use the reference point between the structure and a point 6 feet from the building.
4. Measurements shall be taken at the existing grade or finished grade, whichever is lower.
5. Depressions such as window wells, stairwells for exits required by other codes, “barrier-free” ramps on grade, and vehicle access driveways into garages shall be disregarded in determining structure height when in combination they comprise less than fifty percent of the facade on which they are located. In such cases, the grade for height measurement purposes shall be a line between the grades on either side of the depression.
6. Public amenities allowing additional height can be found in Section 17C.122.090 Public Amenities Allowing Bonus Height.
7. For buildings over 70 feet tall, Chapter 17C.250 Tall Building Standards apply.

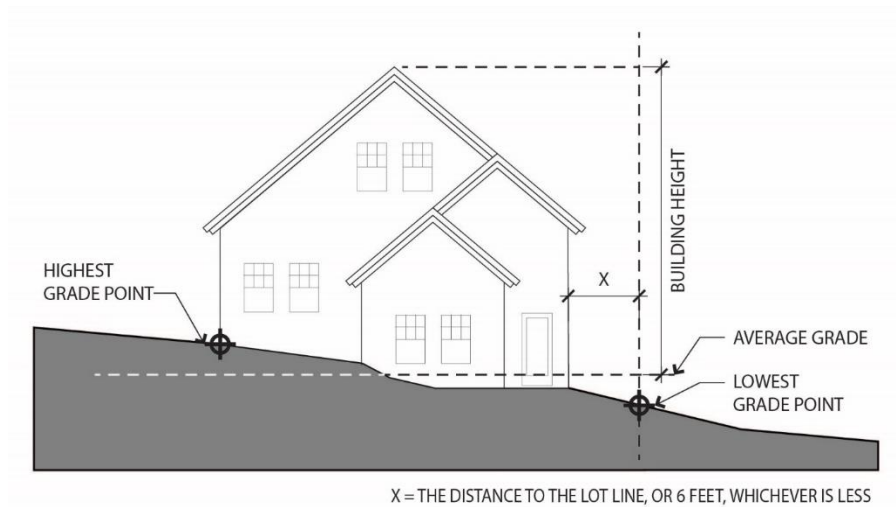

Figure 17C.122.210-A

Section 8. That there is adopted a new Section 17C.122.220 to Chapter 17C.122 SMC to read as follows:

Section 17C.122.220 Height Transition

A. Purpose.

The following exception to the maximum building height standards is to provide a gradual transition and enhance the compatibility between the more intensive center zones and adjacent low and moderate residential zones.

B. Applicability.

For all development adjacent to R1 or R2 zoned properties the maximum building height is as follows:

1. Starting at a height of 40 ft. at R1 and R2 property boundaries, additional building height may be added at a ratio of 2 to 1 (two feet of additional building height for every one foot of additional horizontal distance from the closest R1 or R2 zoned property line).
2. The building height transition requirement ends 150 ft. from the R1 or R2 zoned property line. Beyond the transition, the maximum building height of the zone applies.

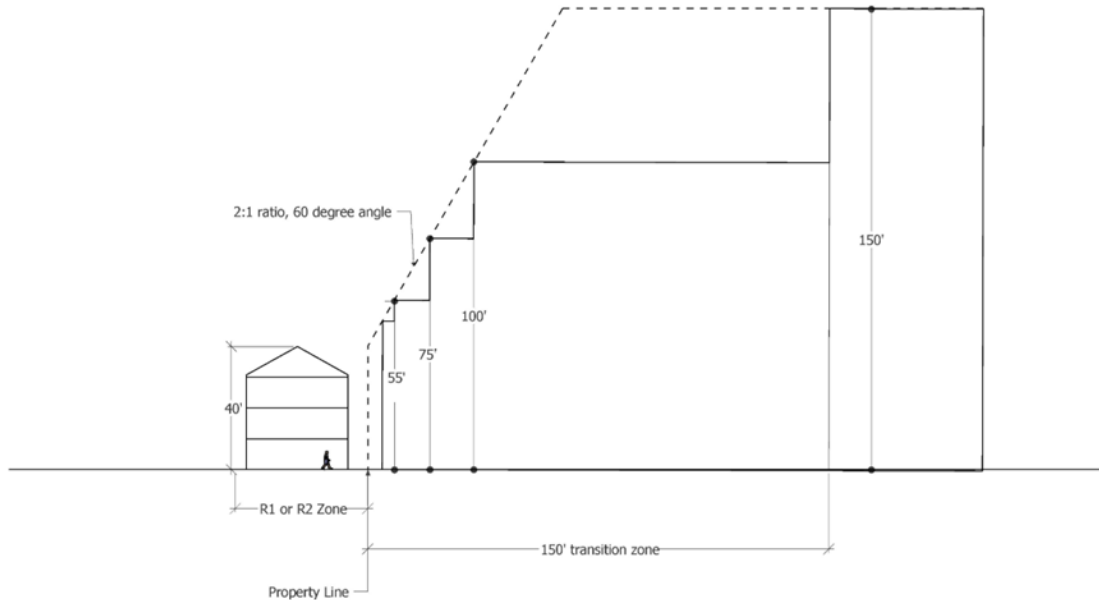

Figure 17C.122.220-A: Height Transition

Section 9. That there is adopted a new Section 17C.122.230 to Chapter 17C.122 SMC to read as follows:

Section 17C.122.230 Floor Area Ratio

A. Floor Area Ratio (FAR).

FAR standards are stated in Table 17C.122.200-2. FAR is the measurement of the building's gross floor area in relation to the size of the lot. A structure that has the same gross floor area as the area of the lot is considered to have a FAR of 1, if the structure has half the gross floor area as the area of the lot the FAR is 0.5. In addition to other dimensional standards FAR is used to ensure the intensity of the structure is appropriate to the zoning.

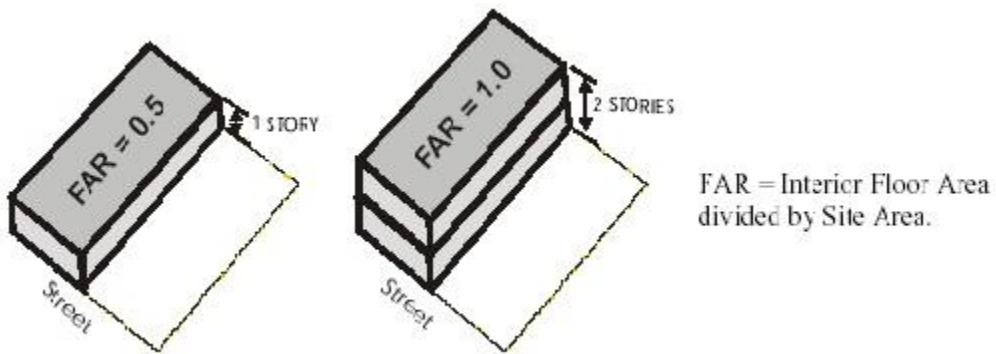

Section 10. That there is adopted a new Section 17C.122.240 to Chapter 17C.122 of the Spokane Municipal Code that SMC to read as follows:

Section 17C.122.240 Setbacks

A. Setbacks.

Setback Standards are stated in Table 17C.122.200-2. Setbacks in Centers and Corridors ensure that there is adequate space between the structure’s facade and the street allowing for ample space for the pedestrian realm.

1. The minimum setback from street lot lines is zero feet and buildings shall be no closer than twelve feet from the back of the curb except as provided in 17C.122.240(A)(2).
2. This width may be reduced, by approval of the Planning Director, if the existing sidewalk is less than twelve feet wide between the back of the curb and the existing building setback line of the adjacent building(s). In no case shall the setback be reduced below nine feet from the back of the curb.

Section 11. That there is adopted a new Section 17C.122.250 to Chapter 17C.122 SMC to that read as follows:

Section 17C.122.250 Sidewalks

A. Sidewalks.

1. Sidewalks shall be at least twelve feet wide and consist of a clear walking path at least seven feet wide (in addition to a planting zone for street trees per SMC 17C.200.050) except as provided in 17C.122.240(A)(2).

Section 12. That Chapter 17C.122T entitled “Center and Corridor Zone Development Tables” is repealed.

Section 13. That SMC Section 17C.230.120 is amended to read as follows:

Section 17C.230.120 Maximum Required Parking Spaces

A. Purpose.

Limiting the number of spaces allowed promotes efficient use of land, enhances urban form, encourages use of alternative modes of transportation, provides for better pedestrian movement, and protects air and water quality. The maximum

ratios in this section vary with the use the parking it is accessory to. These maximums will accommodate most auto trips to a site based on typical peak parking demand for each use.

B. Maximum Number of Parking Spaces Allowed.

Standards in a plan district or overlay zone may supersede the standards in this subsection.

1. Surface Parking.

The maximum number of parking spaces allowed is stated in Table 17C.230.120-1 and Table 17C.230.130-1, except as specified in subsection (B)(2) of this section.

2. Structure Parking.

Parking provided within a building or parking structure is not counted when calculating the maximum parking allowed.

TABLE 17C.230.120-1 PARKING SPACES BY ZONE [1] (Refer to Table 17C.230.130-1 for Parking Spaces Standards by Use)		
ZONE	SPECIFIC USES	REQUIREMENT
RA, R1, R2, RMF, RHD	All Land Uses	Minimum and maximum standards are shown in Table 17C.230.130-1 .
O, OR, NR, NMU, CB, GC, Industrial		
((CC1, CC2, CC3 [2])	Nonresidential	Minimum ratio is 1 stall per 1,000 gross square feet of floor area. Maximum ratio is 4 stalls per 1,000 gross square feet of floor area.
	Residential	Minimum ratio is 1 stall per 1,000 gross square feet of floor area or a minimum of 1 stall per dwelling unit plus one per bedroom after 3 bedrooms. Maximum ratio is the same as for nonresidential uses.

CC4 [2]	Nonresidential	Minimum ratio is 2 stalls per 1,000 gross square feet of floor area. Maximum ratio is 4 stalls per 1,000 gross square feet of floor area.
	Residential	Minimum ratio is 1 stall per 1,000 gross square feet of floor area or a minimum of 1 stall per dwelling unit, whichever is less. Maximum ratio is the same as for nonresidential uses.)
<u>CC1, CC2, CC3, CC4 [2]</u>	<u>Nonresidential</u>	<u>There is no minimum parking requirement.</u> <u>Maximum ratio is 4 stalls per 1,000 gross square feet of floor area.</u>
	<u>Residential</u>	<u>There is no minimum parking requirement.</u> <u>Maximum ratio is 4 stalls per 1,000 gross square feet of floor area.</u>
Downtown [2]	((All Land Uses)) <u>Nonresidential</u>	((See the Downtown Parking Requirement Map 17C.230-M1 to determine if parking is required. - Minimum ratio for areas shown on the map that require parking is 1 stall per 1,000 gross square feet of floor area or a minimum of 1 stall per dwelling unit, whichever is less.)) <u>There is no minimum parking requirement.</u> Maximum ratio is 3 stalls per 1,000 gross square feet of floor area.
	<u>Residential</u>	<u>There is no minimum parking requirement.</u> <u>Maximum ratio is 3 stalls per 1,000 gross square feet of floor area.</u>
FBC [2]	All Land Uses	See SMC 17C.123.040 , Hamilton Form Based Code for off-street parking requirements.
Overlay	All Land Uses	No off-street parking is required. See the No Off-Street Parking Required

		Overlay Zone Map 17C.230-M2 and No Off-Street Parking Required Overlay Zone Map 17C.230-M3.
<p>[1] Standards in a plan district or overlay zone may supersede the standards of this table.</p> <p>[2] See exceptions in SMC 17C.230.130, CC and Downtown Zone Parking Exceptions.</p>		

Section 14. That SMC Section 17C.230.130 is amended to read as follows:

Section 17C.230.130 Parking Exceptions

- A. ~~((In center and corridor downtown, and FBC CA1, CA2, and CA3 zones any new building or building addition with a floor area less than three thousand square feet shall have no parking requirement))~~ Parking is not required for commercial or institutional uses.
- ~~((B. In the neighborhood retail zone, any existing building, new building, or building addition, having a floor area less than three thousand square feet shall have no parking requirement. In addition, if a building has a floor area of five thousand square feet or less, the parking requirement will be determined after deducting the three thousand square foot exemption from the building's floor area. For example, the parking requirement for a four thousand square foot building would be based on one thousand square feet of floor area — i.e., a four thousand square foot building size minus the three thousand square foot exemption.))~~
- ~~((G))~~ B. The Planning Director may approve ratios that are higher than the maximum or lower than the minimum if sufficient factual data is provided to indicate that a different amount is appropriate. The applicant assumes the burden of proof. Approval of parking above the maximum shall be conditioned upon increasing the amount of required landscaping by thirty percent. Approval of parking below the minimum shall be conditioned upon the project contributing towards a pedestrian and transit supportive environment both next to the immediate site and in the surrounding area. When determining if a different amount of parking is appropriate, the Director shall consider the proximity of the site to frequent transit service, the intensity of the zoning designation of the site and surrounding sites, and the form of the proposed use.
- ~~((D))~~ C. If property owners and businesses establish a parking management area program with shared parking agreements, the Planning Director may reduce or waive parking requirements.
- ~~((E))~~ D. Existing legal nonconforming buildings that do not have adequate parking to meet the standards of this section are not required to provide off-street parking when

remodeling which increases the amount of required parking occurs within the existing structure.

~~(F)~~E. Attached Housing.

The following exceptions apply only to attached housing (defined in SMC 17A.020.010) in the RMF and RHD zones. Distances are measured in a straight line between the zone/overlay boundary to the lot line of the site containing the development.

1. On a lot at least partially within one thousand three hundred twenty feet of CC, CA, or DT zone or CC3 zoning overlay, the minimum number of off-street vehicle parking spaces required is fifty percent less than the minimum required for Residential Household Living in Table 17C.230.130-1.
2. On a lot farther than one thousand three hundred twenty feet of a CC, CA, or DT zone or CC3 zoning overlay, the minimum number of off-street vehicle parking spaces required is thirty percent less than the minimum required for Residential Household Living in Table 17C.230.130-1.

~~(G)~~E. Parking is not required for residential development on sites located within one-half mile of a transit stop.

TABLE 17C.230.130-1 PARKING SPACES BY USE [1] (Refer to Table 17C.230.120-1 for Parking Space Standards by Zone) CU = Conditional Use			
RESIDENTIAL CATEGORIES			
USE CATEGORIES	SPECIFIC USES	MINIMUM PARKING	MAXIMUM PARKING
Group Living		((1 per 4 residents)) <u>None</u>	None
Residential Household Living (([2]))		((1 per unit plus 1 per bedroom after 3 bedrooms [3]; Accessory Dwelling Unit (ADU) — see Note [4]; Single Resident Occupancy (SRO) are exempt)) <u>None</u>	None

COMMERCIAL CATEGORIES			
USE CATEGORIES	SPECIFIC USES	MINIMUM PARKING	MAXIMUM PARKING
Adult Business		((1 per 500 sq. ft. of floor area)) <u>None</u>	1 per 200 sq. ft. of floor area
Commercial Outdoor Recreation		((20 per acre of site)) <u>None</u>	30 per acre of site
Commercial Parking		Not applicable	None
Drive-through Facility		Not applicable	None
Major Event Entertainment		((1 per 8 seats or per CU review)) <u>None</u>	1 per 5 seats or per CU review
Office	General Office	((1 per 500 sq. ft. of floor area)) <u>None</u>	1 per 200 sq. ft. of floor area
	Medical/Dental Office	((1 per 500 sq. ft. of floor area)) <u>None</u>	1 per 200 sq. ft. of floor area
Quick Vehicle Servicing		((1 per 500 sq. ft. of floor area)) <u>None</u>	1 per 200 sq. ft. of floor area
Retail Sales and Service	Retail, Personal Service, Repair-oriented	((1 per 330 sq. ft. of floor area)) <u>None</u>	1 per 200 sq. ft. of floor area
	Restaurants and Bars	((1 per 250 sq. ft. of floor area)) <u>None</u>	1 per 60 sq. ft. of floor area
	Health Clubs, Gyms, Lodges, Meeting	((1 per 330 sq. ft. of floor area))	1 per 180 sq. ft. of floor area

	Rooms and similar continuous entertainment, such as Arcades and Bowling Alleys	<u>None</u>	
	Temporary Lodging	((1 per rentable room; for associated uses such as Restaurants, see above)) <u>None</u>	1.5 per rentable room; for associated uses such as Restaurants, see above
	Theaters	((1 per 4 seats or 1 per 6 feet of bench area)) <u>None</u>	1 per 2.7 seats or 1 per 4 feet of bench area
	Retail sales and services of large items, such as appliances, furniture and equipment	((1 per 1,000 sq. ft. of floor area)) <u>None</u>	1 per 200 sq. ft. of floor area
Mini-storage Facilities		((Same as Warehouse and Freight Movement)) <u>None</u>	Same as Warehouse and Freight Movement
Vehicle Repair		((1 per 750 sq. ft. of floor area)) <u>None</u>	1 per 200 sq. ft. of floor area
INDUSTRIAL CATEGORIES			
USE CATEGORIES	SPECIFIC USES	MINIMUM PARKING	MAXIMUM PARKING
Industrial Services, Railroad Yards, Wholesale Sales		((1 per 1,000 sq. ft. of floor area)) <u>None</u>	1 per 200 sq. ft. of floor area

Manufacturing and Production		((1 per 1,000 sq. ft. of floor area)) <u>None</u>	1 per 200 sq. ft. of floor area
Warehouse and Freight Movement		((1 per 1,000 sq. ft. of floor area for the first 3,000 sq. ft. of floor area and then 1 per 3,500 sq. ft. of floor area thereafter)) <u>None</u>	1 per 200 sq. ft. of floor area
Waste-related		Per CU review	Per CU review
INSTITUTIONAL CATEGORIES			
USE CATEGORIES	SPECIFIC USES	MINIMUM PARKING	MAXIMUM PARKING
Basic Utilities		None	None
Colleges		((1 per 600 sq. ft. of floor area exclusive of dormitories, plus 1 per 4 dorm rooms)) <u>None</u>	1 per 200 sq. ft. of floor area exclusive of dormitories, plus 1 per 2.6 dorm room
Community Service		((1 per 500 sq. ft. of floor area)) <u>None</u>	1 per 200 sq. ft. of floor area
Daycare		((1 per 500 sq. ft. of floor area)) <u>None</u>	1 per 200 sq. ft. of floor area
Medical Centers		((1 per 500 sq. ft. of floor area)) <u>None</u>	1 per 200 sq. ft. of floor area
Parks and Open Areas		((Per CU review for active areas))	Per CU review for active areas

		<u>None</u>	
Religious Institutions		((1 per 100 sq. ft. of main assembly area or per CU review)) <u>None</u>	1 per 60 sq. ft. of main assembly area
Schools	Grade, Elementary, Junior High	((1 per classroom)) <u>None</u>	2.5 per classroom
	High School	((7 per classroom)) <u>None</u>	10.5 per classroom

OTHER CATEGORIES

USE CATEGORIES	SPECIFIC USES	MINIMUM PARKING	MAXIMUM PARKING
Agriculture		None or per CU review	None or per CU review
Aviation and Surface Passenger Terminals		Per CU review	Per CU review
Detention Facilities		Per CU review	Per CU review
Essential Public Facilities		Per CU review	Per CU review
Wireless Communication Facilities		None or per CU review	None or per CU review
Rail Lines and Utility Corridors		None	None

[1] The Planning Director may approve different amounts of parking spaces under the exceptions listed in SMC 17C.230.130.

~~(([2] Parking is not required for residential development on sites located within one-half mile of a transit stop.))~~

~~(([3] For middle housing developed in the R1 and R2 zones, the following standards apply:~~

- ~~• On lots smaller than 6,000 square feet, only one parking space per unit is required regardless of bedroom count.~~

- ~~• On lots 6,000 square feet or larger, each unit with 4 or more bedrooms must provide a minimum of two parking spaces.))~~

~~(([3] Single Room Occupancy housing is exempted from parking requirements.))~~

~~(([4] Parking requirements for ADUs are provided in SMC 17C.300.130(A)(4).))~~

Section 15. That SMC Section 17C.300.130 is amended to read as follows:

Section 17C.300.130 Development Standards

A. Development Standards – Requirements for All Accessory Dwelling Units.

All accessory dwelling units must meet the following:

1. Creation.

An accessory dwelling unit may only be created through the following methods:

- Converting existing living area, attic, basement or garage.
- Adding floor area.
- Constructing a detached accessory dwelling unit on a site with an existing residential use.
- Constructing a residential use with an internal or detached accessory dwelling unit.
- In the R1, R2, RMF, or RHD zone, constructing an attached or detached accessory dwelling unit on a site with any existing or new principal structure (including non-residential uses or structures). Any structure shall comply with all applicable building, fire, and engineering standards.

2. Number of Residents.

The total number of individuals that reside in all units on the site may not exceed any lawful limits on occupant load per square foot or generally applicable health and safety provisions as established by applicable building or fire code, as provided in RCW 35.21.682.

3. Location of Entrances for Internal ADUs.

Only one entrance may be located on the facade of the structure facing the street, unless the principal structure contained additional entrances before the accessory dwelling unit was created. An exception to this regulation is entrances that do not have access from the ground such as entrances from balconies or decks.

4. Parking.

- a. Studio and one-bedroom ADUs require no additional parking. ~~((One additional off-street parking space is required for the accessory dwelling unit with more than one bedroom, plus one per bedroom after two bedrooms. Existing required parking for the principal structure must be maintained.))~~
- ~~((b. As an exception to subsection (a), no additional off-street parking space is required for the ADU within one-quarter mile of stops for a bus or other transit mode providing actual fixed route service at intervals of no less frequently than fifteen minutes for at least five hours during the peak hours of operation on weekdays, defined as a major transit stop under RCW 36.70A.696.))~~
- b. Parking for Accessory Dwelling Units is provided in Table 17C.230.130-1 under Residential Household Living. For purposes of determining required parking, an Accessory Dwelling Unit is a full dwelling unit.

B. Additional Development Standards for Detached ADUs.

1. Setbacks.

Except for conversion of existing accessory structures, the accessory dwelling unit must be:

- a. as specified for setbacks in [Table 17C.111.205-2](#) for accessory structures and

2. Height.

The maximum height allowed for a detached accessory dwelling unit is provided in [Table 17C.111.205-2](#).

3. Bulk Limitation.

The building coverage for the detached accessory dwelling unit may not be larger than the building coverage of the principal structure.

- a. On lots five thousand five hundred square feet or larger, the combined building coverage of all detached accessory structures may not exceed fifteen percent of the total area of the site.

- b. On lots smaller than five thousand five hundred square feet, the combined building coverage of all detached accessory structures may not exceed twenty percent of the total area of the site.

4. Conversion of Existing Detached Accessory Structures.

- a. Conversion of an existing detached accessory structure that is in a front building setback required by [Table 17C.111.205-2](#) is not allowed. Conversion of an existing detached accessory structure

that is in a rear or side building setback is allowed as provided by [SMC 17C.111.235](#), Setbacks, and [SMC 17C.111.240](#), Accessory Structures.

- b. If the accessory dwelling unit is proposed for an existing detached accessory structure that meets any of the standards of subsections (B)(2) and (3) of this section, alterations that will move the structure out of conformance with the standards that are met are not allowed.
- c. If the accessory dwelling unit is proposed as a conversion of an existing detached accessory structure or a portion of the building, and any floor area is added to the existing detached accessory structure to accommodate an ADU, then the entire structure must meet the underlying zoning development standards.

C. Utilities and Addressing.

The ADU must utilize those municipal utilities and address established for the principal dwelling unit.

D. Code Compliance.

The ADU must meet all technical code standards of this title including building, electrical, fire, and plumbing code requirements and permits.

PASSED by the City Council on _____.

Council President

Attest:

Approved as to form:

City Clerk

Assistant City Attorney

Mayor

Date

Effective Date

**CITY OF SPOKANE PLAN COMMISSION
FINDINGS OF FACT, CONCLUSIONS, AND RECOMMENDATIONS
REGARDING CENTER AND CORRIDOR AND RELATED CODE AMENDMENTS**

A recommendation of the City of Spokane Plan Commission to the City Council to approve amendments to the Spokane Municipal Code proposed Center and Corridor update text amendments. The proposal amends the Unified Development Code (UDC) Sections 17C.122.070, 17C.122.090, 17C.230.120, 17C.230.130, and 17C.300.130, repeals Sections 17C.122.080, 17C.122.100, 17C.122.110, and 17C.122T, and adopts new Sections 17C.122.200, 17C.122.210, 17C.122.220, 17C.122.230, 17C.122.240, and 17C.122.250 to implement the adopted South Logan Transit-Oriented Development Plan.

FINDINGS OF FACT:

- A. The City of Spokane adopted a Comprehensive Plan in May of 2001 that complies with the requirements of the Growth Management Act (GMA) as set forth in RCW 36.70A.
- B. In 2021, the Washington State Legislature appropriated \$2.5 million for cities to facilitate transit-oriented development planning in areas with light rail or fixed rail systems, bus rapid transit, high frequency bus service or park and ride lots.
- C. The City of Spokane prepared the Transit-Oriented Development (TOD) Framework Action Plan, adopted by resolution in May 2022 under RES 2022-0039, that identifies strategies best suited to Spokane for supporting TOD along new High-Performance Transit lines, including a focus on South Logan.
- D. The City provided opportunities for meaningful public involvement and review in the South Logan TOD Plan and EIS process, including a community meeting consistent with RCW 43.21C.440; has considered all comments received; and, as appropriate, has modified the proposal or mitigation measures in response to comments, resulting in the Preferred Alternative analyzed in the Final Environmental Impact Statement (FEIS).
- E. The *Final South Logan TOD Plan* and *Final Environmental Impact Statement (FEIS)* were published on November 30, 2023 for final consideration.
- F. On January 29, 2024 Spokane City Council adopted by resolution (RES 2024-0015) the Final South Logan TOD Plan and FEIS as a declaration of the subarea's desired future condition.
- G. City Council adopted interim development regulations under ORDINANCE NO. C36232 on July 18, 2022, including Section 17C.400.040 Pilot Center and Corridors Development Standards, that expired June 28, 2024. In order to facilitate the envisioned future development in the Plan, the adopted Final South Logan TOD Plan assumed interim Center and Corridor development regulations would be made permanent.

Findings of Fact, Conclusion, and Recommendation

- H. An ongoing Center and Corridor Study further informed proposed adjustments to the Center and Corridor development regulations to support increase feasibility of transit-supportive and pedestrian-oriented development.
- I. For regulatory consistency throughout Spokane and to ensure the benefits of increased feasibility, the amendments are proposed to affect citywide development regulations.
- J. The draft amendments relied on the 20-month planning process and extensive public engagement that occurred as part of the development of the South Logan TOD Plan. Outreach and public communication specifically about South Logan TOD Implementation began in February 2024 and included the following among others:
 - 1. Logan Neighborhood Council meeting presentation on February 13, 2024;
 - 2. Plan Commission Workshops on March 13, April 10, April 24, May 8, May 22, and June 12, 2024;
 - 3. Various community tabling events on March 19, April 9, and May 18, 2024;
 - 4. A virtual information session on April 30, 2024;
 - 5. Coffee Chat pop-up events on May 4, May 23, and June 1, 2024;
 - 6. Regular South Logan TOD newsletter and webpage updates, as well as City of Spokane newsletter and social media posts.
- K. Public comment, as well as agency and department comments, received prior to the June 26, 2024, Plan Commission public hearing were included in the staff report.
- L. On March 13, April 10, April 24, May 8, May 22, and June 12, 2024, the Spokane Plan Commission held workshops to discuss draft language, receive updates on public feedback as well as city department and agency comments, and review and evaluate with city staff alternatives to proposed text changes.
- M. On April 29, 2024, the Washington State Department of Commerce and appropriate state agencies were given the required 60-day notice of the City's intent to adopt updated development regulations pursuant to RCW 36.70A.106.
- N. On April 29, 2024, a Notice of Intent to Adopt and Request for SEPA agency comments was issued for the draft code pertaining to the proposed South Logan TOD Implementation text amendments. The comment period ended on May 13, 2024. No comments were received.
- O. The SEPA Determination of Nonsignificance and Checklist were issued by Planning Services on June 12, 2024. The comment period ended on June 26, 2024. No comments were received.

Findings of Fact, Conclusion, and Recommendation

- P. Prior to the Plan Commission public hearing, a legal notice was published in the *Spokesman-Review* on June 12 and June 19, 2024; and
- Q. The proposed text amendments were drafted and reviewed pursuant to the process established under RCW 36.70A.370 to ensure that the proposed changes will not result in unconstitutional takings of private property.
- R. Amendments to Title 17 are subject to review and recommendation by the Plan Commission.
- S. On June 26, 2024, the Spokane Plan Commission held a public hearing on the proposed text amendments, including the taking of verbal testimony, and closed the public record on that date.
- T. Public comment, as well as agency and department comments, received prior to the June 26, 2024 Plan Commission public hearing were included in the staff report.
- U. During deliberations held on June 26, 2024, the Plan Commission discussed the concerns expressed in public comments and testimony about public safety within the South Logan Subarea.
- V. Except as otherwise indicated in the above findings, the Spokane Plan Commission adopts the findings and analysis set forth in the staff report prepared for the proposal.
- W. The Spokane Plan Commission finds that the proposed text amendments meet the decision criteria established in SMC 17G.025.010(G).

CONCLUSIONS:

Based upon the draft text amendments, staff report and analysis (which is hereby incorporated into these findings, conclusions, and recommendations), SEPA review, agency and public comments received, and public testimony presented, the Spokane Plan Commission makes the following conclusions with respect to the text amendments to the Hamilton Form-Based Code:

1. The Plan Commission finds that the proposed amendments bear a substantial relation to the public health, safety, welfare, and protection of the environment pursuant to the requirements outlined in SMC 17G.025.010(G).
2. The proposed text amendments will implement the goals and policies of the Comprehensive Plan.
3. The proposed text amendments will implement the adopted South Logan Transit-Oriented Development Plan.

Findings of Fact, Conclusion, and Recommendation

4. Interested agencies and the public have had extensive opportunities to participate throughout the process and persons desiring to comment were given an opportunity to comment.
5. SEPA review was completed for the proposal, and pursuant to SEPA, any adverse environmental impacts associated with the proposed regulations will be mitigated by enforcement of the City's development regulations.
6. Plan Commission concludes that the intent of the including neighborhood councils to the list of entities that receive notice of applications was to give neighborhood councils standing and the ability to advocate for their neighborhood residents. As entities of standing, neighborhood councils should assume the responsibility of proactively communicated with their residents about pertinent all-city or neighborhood-specific development applications.
7. The Plan Commission finds that the proposed amendments are consistent with the applicable provisions of the Comprehensive Plan, particularly the following adopted goals and policies:
 - a. Chapter 3: Land Use – Goal 1 – Citywide Land Use, Policy LU 1.4 Higher Intensity Residential Areas
 - b. Chapter 3: Land Use – Goal 3 – Efficient Land Use, Policy LU 3.1 Coordinated and Efficient Land Use
 - c. Chapter 3: Land Use – Goal 3 – Efficient Land Use, Policy LU 3.2 Centers and Corridors
 - d. Chapter 3: Land Use – Goal 3 – Efficient Land Use, Policy 3.5 Mix of Uses in Centers
 - e. Chapter 3: Land Use – Goal 4 – Transportation, Policy LU 4.1 Land Use and Transportation
 - f. Chapter 3: Land Use – Goal 4 – Transportation, Policy LU 4.6 Transit-Supported Development
 - g. Chapter 3: Land Use – Goal 5 – Development Character, Policy LU 5.1 Built and Natural Environment
 - h. Chapter 3: Land Use – Goal 5 – Development Character, Policy LU 5.5 Complementary Development
 - i. Chapter 6: Housing – Goal H1 – Housing Choice and Diversity, Policy H 1.4 Use of Existing Infrastructure
 - j. Chapter 6: Housing – Goal H1 – Housing Choice and Diversity, Policy H 1.7 Socioeconomic Integration
 - k. Chapter 6: Housing – Goal H1 – Housing Choice and Diversity, Policy H 1.11 Access to Transportation

Findings of Fact, Conclusion, and Recommendation

- I. Chapter 8: Urban Design and Historic Presentation – Goal DP 1 – Price and Identity, Policy DP 1.2 New Development in Established Neighborhoods
 - m. Chapter 8: Urban Design and Historic Preservation – Goal DP 2 – Urban Design, Policy DP 2.2 Design Guidelines and Regulations
 - n. Chapter 8: Urban Design and Historic Preservation – Goal DP 2 – Urban Design, Policy DP 2.6 Building and Site Design
 - o. Chapter 8: Urban Design and Historic Preservation – Goal DP 2 – Urban Design, Policy DP 2.7 Historic District and Sub-Area Design Guidelines
 - p. Chapter 8: Urban Design and Historic Preservation – Goal DP 2 – Urban Design, Policy DP 2.12 Infill Development
 - q. Chapter 8: Urban Design and Historic Preservation – Goal DP 2 – Urban Design, Policy 2.13 Parking Facilities Design
 - r. Chapter 11: Neighborhoods – Goal N 4 – Traffic Circulation, Policy N 4.7 Pedestrian Design
8. The Plan Commission recognizes the concerns expressed by community members about public safety within the South Logan Subarea. While the Plan Commission urges continued community collaboration with public safety and code enforcement officials, the body recognizes the positive impact that transit-oriented and pedestrian-oriented development can have on public safety within the built environment. Increased density and mix of uses made possible with amendments to the Center and Corridor zones, higher intensity residential zones, and height allowances, as well as street activation as called for in the Hamilton Form-Based Code, encourage more eyes on the street and have been found to have a positive effect on safety and walkability.

RECOMMENDATION:

In the matter of the ordinance pertaining to the Hamilton Form-Based Code, amending the Unified Development Code of the City of Spokane:

1. By a vote of seven to zero, the City of Spokane Plan Commission recommends to the Spokane City Council the **APPROVAL** of the proposed amendments to Sections 17C.122.070, 17C.122.090, 17C.230.120, 17C.230.130, and 17C.300.130, repeal of Sections 17C.122.080, 17C.122.100, 17C.122.110, and 17C.122T, and adoption of new Sections 17C.122.200, 17C.122.210, 17C.122.220, 17C.122.230, 17C.122.240, and 17C.122.250.
2. The City of Spokane Plan Commission authorizes the Plan Commission President to prepare and sign on the Commission's behalf a written decision setting forth the Plan Commission's findings, conclusions, and recommendations on the proposed amendments.

Findings of Fact, Conclusion, and Recommendation

Greg Francis
Greg Francis (Jun 27, 2024 17:43 PDT)

Greg Francis, President
Spokane Plan Commission

Jun 27, 2024 enter a date.

PC Findings and Conclusions_ Center and Corridor

Final Audit Report

2024-06-28

Created:	2024-06-27
By:	AMANDA KIEHN (AKIEHN@SPOKANECITY.ORG)
Status:	Signed
Transaction ID:	CBJCHBCAABAA-An5inyFbGwiOIskSsaYqQjQaqvFJBQq

"PC Findings and Conclusions_ Center and Corridor" History

 Document created by AMANDA KIEHN (AKIEHN@SPOKANECITY.ORG)

2024-06-27 - 10:03:06 PM GMT

 Document emailed to gfrancis@spokanecity.org for signature

2024-06-27 - 10:04:08 PM GMT

 Email viewed by gfrancis@spokanecity.org

2024-06-28 - 0:42:01 AM GMT

 Signer gfrancis@spokanecity.org entered name at signing as Greg Francis

2024-06-28 - 0:42:59 AM GMT

 Document e-signed by Greg Francis (gfrancis@spokanecity.org)

Signature Date: 2024-06-28 - 0:43:01 AM GMT - Time Source: server

 Agreement completed.

2024-06-28 - 0:43:01 AM GMT