

## CITY OF SPOKANE



### REGARDING CITY COUNCIL MEETINGS

City Council's standing committee meetings, Briefing Sessions, Legislative Sessions and study sessions are normally held in City Council Chambers – Lower Level of City Hall, 808 W. Spokane Falls Blvd.

**City Council's June 10, 2024, 6:00 p.m. Legislative Session will take place at the Dr. Martin Luther King Jr. Community Center – Multi-Purpose Room, 500 S. Stone St. (The 3:30 p.m. Briefing Session on June 10 will be held in the Council Chambers.)**

**Please note that the 6:00 p.m. meeting will not be live on City Cable 5 but will be recorded for future viewing on the City Council's Vimeo page: <https://vimeo.com/spokanecitycouncil>.**

City Council Members, City staff, presenters and members of the public have the option to participate virtually via WebEx during all meetings, with the exception of Executive Sessions which are closed to the public. Call in information for the June 10, 2024, meetings is below.

#### **WebEx call in information for the week of June 10, 2024:**

3:30 p.m. Briefing Session: 1-408-418-9388; access code: 249 250 76017; password: 0320

6:00 p.m. Legislative Session: 1-408-418-9388; access code: 248 526 21883; password: 0320

Thursday Study Session: 1-408-418-9388; access code: 249 143 67432; password: 0320

#### **To participate in public comment (including Open Forum):**

Testimony sign-up is open by 5:00 p.m. on Friday, June 7, 2024, and ending at 6:00 p.m. on Monday, June 10, 2024, via the online testimony sign-up form link which can be accessed by clicking <https://forms.gle/Vd7n381x3seaL1NW6> or in person outside council chambers beginning at 8:00 a.m. on June 10, 2024. **Because the 6:00 p.m. Legislative Session is being held at the Dr. Martin Luther King Jr. Community Center, in person sign up outside council chambers will end at 5:00 p.m. You will still have the ability to sign up until 6:00 p.m. utilizing the sign-up form link. There also will be the ability to sign up in person at the Dr. Martin Luther King Jr. Community Center from 5:00 p.m. to 6:00 p.m.** You must sign up by 6:00 p.m. to be called on to testify. (If you are unable to access the form by clicking the hyperlink, please copy and paste the link address into your browser window.) Instructions for participation are provided on the form when you sign up.

Pursuant to the City Council's rules, the Open Forum is now held at the end of the city council's legislative session. **Because the June 10 meeting is a "Town Hall" council meeting away from the council's regular meeting place, the city council expects to conclude all business, including**

**Open Forum, by 8:30 p.m.** The open forum is a limited public forum; all matters discussed in the open forum shall relate to the affairs of the City and not relating to the current or advance agendas, pending hearing items, or initiatives or referenda in a pending election. "Affairs of the city" shall include (i) matters within the legislative, fiscal or regulatory purview of the city, (ii) any ordinance, resolution or other official act adopted by the city council, (iii) any rule adopted by the city, (iv) the delivery of city services and operation of city departments, (v) any act of members of the city council, the mayor or members of the administration, or (vi) any other matter deemed by the council president to fall within the affairs of the city, which determination may be overridden by majority vote of the council members present. Individuals speaking during the open forum shall address their comments to the council president and shall maintain decorum as laid out in Rule 2.15 (Participation by Members of the Public in Council Meetings).



**CITY COUNCIL MEETINGS  
RULES – PUBLIC DECORUM**

**Strict adherence to the following rules of decorum by the public will be observed and adhered to during City Council meetings, including open forum, public comment period on legislative items, and Council deliberations:**

- 1. No Clapping!**
- 2. No Cheering!**
- 3. No Booing!**
- 4. No public outbursts!**
- 5. Two-minute time limit for comments made during open forum, and three-minute time limit on public testimony regarding legislative items!**

**In addition, please silence your cell phones when entering the Council Chambers!**

Further, keep the following City Council Rules in mind:

**Rule 2.2 OPEN FORUM**

- A. After the conclusion of all legislative business, the council shall recess briefly and then convene for an open forum, unless a majority of council members vote otherwise. The open forum shall have twenty (20) spaces available. The individuals assigned to the twenty (20) spaces available will be chosen at random, with preference given to individuals who have not spoken at open forum during that calendar month. The council shall conclude open forum after twenty (20) speakers unless a majority of council members vote to allow additional speakers. The city clerk and other staff shall not be required to remain in attendance during the open forum. Nothing in this Rule 2.2 shall be deemed to require open forum or the legislative session to continue after 10:00 p.m., or to require open forum during a council “Town Hall” meeting contrary to Rule 2.14.F.
- B. Members of the public can sign up for open forum beginning no later than 5:00 p.m. on the Friday immediately preceding the legislative session and ending at 6:00 p.m. on the date of the meeting via the virtual testimony form linked in the meeting packet or in person outside council chambers beginning at 8:00 a.m. on the day of the legislative session. Speakers must sign themselves in using a name. Members of the public who are unable to sign up during the sign-up period or who attempt to sign up late will be added to the list of speakers at the discretion of the chair, or their designee. The order of the speakers will be determined at the discretion of the chair, taking into account any special accommodations for persons of limited English proficiency as provided in Rule 2.2.F below. Each speaker shall be limited to no more than two (2) minutes unless a majority of the council members in attendance vote on an alternate time limit.
- C. No action, other than a statement of council members’ intent to address the matter in the future, points of order, or points of information will be taken by council members during an open forum.
- D. The open forum is a limited public forum and all matters discussed in the open forum shall relate to the affairs of the city. “Affairs of the city” shall include (i) matters within the legislative, fiscal or regulatory purview of the city, (ii) any ordinance, resolution or other official act adopted by the city council, (iii) any rule adopted by the city, (iv) the delivery of city services and operation of city departments, (v) any act of members of the city council, the mayor or members of the administration, or (vi) any other matter deemed by the council president to fall within the affairs of the city, which determination may be overridden by majority vote of the council members present. Absent permission of the chair, no person shall be permitted to speak in open forum regarding items on that week’s current agenda or the next week’s advanced agenda, pending hearing items, or initiatives or referenda in a pending election. Legal or personal matters between private parties that do not impact the governance of the City of Spokane are not a permissible topic of open forum testimony.
- E. No person shall be permitted to display visual information during open forum, including but not limited to presentations, videos, or other media; however, members of the public may share this information with the council by emailing them at [citycouncil2@spokanecity.org](mailto:citycouncil2@spokanecity.org). Individuals speaking during open forum shall address their comments to the council president, and speakers as well as members of the audience shall comply with Rule 2.15 (Participation by Members of the Public in Council Meetings).
- F. Participation of individuals with limited English language proficiency in open forum shall be accommodated to the extent set forth in Rule 2.15.J.

**Rule 2.7 SERVICE ANIMALS AT CITY COUNCIL MEETINGS**

- A. For purposes of these Rules, only dogs that are individually trained to do work or perform tasks for a person with a disability are recognized as service animals. Dogs or other animals whose sole function is to provide comfort or emotional support do not qualify as service animals under these Rules. Service animals are permitted to accompany people with disabilities in City Council meetings, as well as all areas where members of the public are allowed to go.

- B. Service animals must, at all times while present in a City Council meeting, be harnessed, leashed, or tethered, unless these devices interfere with the service animal's work or the individual's disability prevents using these devices, in which case, the individual must maintain control of the animal through voice, signal, or other effective controls.

## **Rule 2.15 PARTICIPATION OF MEMBERS OF THE PUBLIC IN COUNCIL MEETINGS**

The council encourages public participation in the legislative process. Council meetings shall be conducted in a manner that provides the opportunity for all attendees to hear, see and participate in the proceedings to the extent provided in these Rules and applicable city, state, and federal law. Speech or conduct that disrupts, disturbs, or otherwise impedes the orderly conduct of any council meeting is prohibited. In addition to these general principles governing public participation, the following specific rules apply:

- A. Members of the public may address the council regarding the following items during the council's legislative session: the consent agenda as a whole, all first reading ordinances together (with the exception of first reading ordinances associated with hearings, which shall be taken separately), final readings of regular and special budget ordinances, emergency ordinances, hearing items, special considerations, and other items before the city council requiring council action, except those that are adjudicatory or solely administrative in nature. This rule shall not limit the public's right to speak on issues that are not part of the current or advanced agendas during open forum.
- B. No member of the public may speak without first being recognized for that purpose by the chair. Except for named parties to an adjudicative hearing, a person may be required to sign a sign-up sheet and provide their city of residence as a condition of recognition. Council members must be recognized by the chair for the purpose of obtaining the floor.
- C. Each person speaking in a public council meeting shall verbally identify themselves by name, city of residence, and, if appropriate, representative capacity.
- D. Each speaker shall follow all written and verbal instructions so that verbal remarks are electronically recorded, and documents submitted for the record are identified and marked by the clerk.
- E. Those who wish to provide commentary but do not wish to give verbal comments at the podium may provide written comments to the council via letter or electronic mail.
- F. No person shall be permitted to conduct demonstrations, display banners, hold signs, applaud or boo speakers, use profanity, vulgar language or obscene speech, yell or make comments that attack or verbally insult any individual, or engage in other such disorderly conduct that disrupts, disturbs, or otherwise impedes the orderly conduct of the proceedings.
- G. Standing is permitted so long as doing so maintains compliance with applicable fire codes and the Americans with Disability Act (ADA), does not interfere with reserved seating areas, and does not impede access to entrances and exits to the Council Chambers, aisles, or pathways inside the Council Chambers. Attendees shall be mindful not to obstruct the views of others in Council Chambers when standing.
- H. A speaker asserting a statement of fact may be asked by a council member to document and identify the sources of the factual datum being asserted.
- I. When addressing the council, members of the public shall direct all remarks to the council president, shall refrain from remarks directed personally to any council member or any other individual, and shall confine remarks to the matters that are specifically before the council at that time.
- J. City employees or city officials (including members of city boards and commissions) may participate in public comment, including open forum, providing they are in compliance with the City of Spokane Code of Ethics and they do the following:
  - 1. Announce at the beginning of their testimony that they are there in their personal capacity or their capacity as a member of a relevant board, commission, committee or community group;
  - 2. Protect confidential information, including, but not limited to, confidential financial information and attorney-client communications;
  - 3. Do not use, or be perceived to use, city funds, including giving testimony during paid work time or while in uniform; or city property, including using a city-issued computer or cell phone, in giving testimony.
- K. When any person, including members of the public, city staff, and others, are addressing the council, council members shall observe the same decorum and process as the rules require among the members *inter se*. That is, a council member shall not engage the person addressing the council in colloquy but shall speak only when granted the floor by the council president. All persons and/or council members shall not interrupt one another. The duty of mutual respect and avoiding unlawful harassment set forth in Rule 1.2 and the rules governing debate set forth in *Robert's Rules of Order, Newly Revised*, shall extend to all speakers before the city council. The city council's policy advisor and/or a city attorney shall, with the assistance of council staff, assist the council president to ensure that all individuals desiring to speak shall be identified,

appropriately recognized, and provided the opportunity to speak. All persons attending city council meetings or city council sponsored meetings shall refrain from harassing other attendees or risk being removed and/or prohibited from attending future meetings.

- L. The city council intends to fully comply with chapter 18.11 SMC, Language Access in Municipal Proceedings. Rules regarding participation of individuals in council proceedings, including legislative sessions and open forum, shall be deemed amended to conform to any Language Access Plan adopted by the council pursuant to SMC 18.11.030. Except as otherwise provided in an adopted Language Access Plan, individuals with limited English language proficiency are encouraged to contact the council office director at least five (5) days prior to a scheduled legislative session for assistance with the signing up to testify or to arrange translation or interpretation assistance.
- M. City council legislative sessions are regularly video and audio recorded and available online (<https://vimeo.com/spokanecitycouncil>). Members of the public may also photograph or film council proceedings so long as doing so maintains compliance with applicable fire codes and the Americans with Disability Act (ADA), does not interfere with reserved seating areas, and does not impede access to entrances and exits to the Council Chambers, aisles, or pathways inside the Council Chambers. Attendees shall be mindful not to obstruct the views of others in Council Chambers when photographing or recording. No flash photography or other lighting is permitted.
- N. RCW 42.17A.555 generally prohibits the use of city facilities for electioneering. Therefore, no person may use the council meeting or facilities for the purpose of assisting a campaign for election of any person to any office, or for the promotion of or opposition to any ballot proposition. In this context, the term “facilities” includes council chambers, the council gallery and the speaking opportunities available through the public comment and open forum procedures set forth in these rules.

#### **Rule 2.16 PUBLIC TESTIMONY REGARDING LEGISLATIVE AGENDA ITEMS – TIME LIMITS**

- A. Members of the public can sign up to give testimony beginning no later than 5:00 p.m. on the Friday immediately preceding the legislative session and ending at 6:00 p.m. on the date of the meeting via the online testimony sign-up form linked in the meeting packet or in person outside council chambers beginning at 8:00 a.m. on the day of the legislative session. Speakers must sign in using a name. Members of the public who are unable to sign up during the sign-up period or who attempt to sign up late will not be added to the list of speakers. The order of the speakers shall be determined at the discretion of the chair.
- B. The city council shall take public testimony on all matters included on its legislative agenda as described at Rule 2.15(A), with those exceptions stated in Rule 2.16(B). Public testimony shall be limited to the final council action, except that public testimony shall be allowed at the first reading of ordinances. Public testimony shall be limited to three (3) minutes per speaker. The chair, absent a majority vote of the council, has the authority to lower the three (3) minutes per speaker time limit by announcing the new, lower time limit at the legislative session. The chair may allow additional time if the speaker is asked to respond to questions from the council. Public testimony and consideration of an item may be extended to a subsequent meeting by a majority vote of the council. Testimony on a legislative item deferred to a future date shall be taken on the future date, unless testimony on the date of deferral is allowed by the Council President.
- C. No public testimony shall be taken on oral amendments to consent or legislative agenda items, votes to override a mayoral veto, or solely procedural, parliamentary, or administrative matters of the council.
- D. Public testimony will be taken on consent and legislative items that are moved to council’s regular briefing session or study session unless a majority of council votes otherwise during the meeting in which the items are moved.
- E. For legislative or hearing items that may affect an identifiable individual, association, or group, the following procedure may be implemented at the discretion of the council president:
  - 1. Following an assessment by the chair of factors such as complexity of the issue(s), the apparent number of people indicating a desire to testify, representation by designated spokespersons, etc., the chair shall, in the absence of objection by the majority of the council present, impose the following procedural time limitations for taking public testimony regarding legislative matters:
    - a. There shall be up to fifteen (15) minutes for staff, board, or commission presentation of background information, if any.
    - b. The designated representative of the proponents of the issue shall speak first and may include within their presentation the testimony of expert witnesses, visual displays, and any other reasonable methods of presenting the case. Up to thirty (30) minutes may be granted for the proponent’s presentation. If there be more than one designated representative, they shall allocate the allotted time between or among themselves.
    - c. Following the presentation of the proponents of the issue, three (3) minutes shall be granted for any other person not associated with the designated representative of the proponents who wishes to

Speak on behalf of the proponent's position.

- d. The designated representative, if any, of the opponents of the issue shall speak following the presentation of the testimony of expert witnesses, visual displays, and any other reasonable methods of presenting the case. The designated representative(s) of the opponents shall have the same amount of time which was allotted to the proponents.
  - e. Following the presentation by the opponents of the issue, three (3) minutes shall be granted for any other person not associated with the designated representative of the opponents who wishes to speak on behalf of the opponents' position.
  - f. Up to ten (10) minutes of rebuttal time may be granted to the designated representative for each side, the proponents speaking first, the opponents speaking second.
2. In the event the party or parties representing one side of an issue has a designated representative and the other side does not, the chair shall publicly ask the unrepresented side if they wish to designate one or more persons to utilize the time allotted for the designated representative. If no such designation is made, each person wishing to speak on behalf of the unrepresented side shall be granted three (3) minutes to present their position, and no additional compensating time shall be allowed due to the fact that the side has no designated representative.
  3. In the event there appears to be more than two groups wishing to advocate their distinct positions on a specific issue, the chair may grant the same procedural and time allowances to each group or groups, as stated previously.
  4. In the event that the side for which individuals wish to speak is not identified, those wishing to give testimony shall be granted three (3) minutes to present their position after all sides have made their initial presentations and before each side's rebuttal period.
- F. The time taken for staff or council member questions and responses thereto shall be in addition to the time allotted for any individual or designated representative's testimony.
  - G. No person shall be permitted to display visual information during their testimony, including but not limited to presentations, videos, or other media; however, members of the public may share this information with the council by emailing them at [citycouncil2spokanecity.org](mailto:citycouncil2spokanecity.org).
  - H. In addition to in-person or remote verbal testimony, testimony may also be submitted by mail to City Council Office, Spokane City Hall, 808 W. Spokane Falls Blvd., Spokane, WA, 99201, by email to all council members, or via the contact form on the council's website.<sup>1</sup>

---

<sup>1</sup> <https://my.spokanecity.org/citycouncil/members/>

# THE CITY OF SPOKANE



## ADVANCE COUNCIL AGENDA

MEETING OF MONDAY, JUNE 10, 2024

### **MISSION STATEMENT**

**TO DELIVER EFFICIENT AND EFFECTIVE SERVICES  
THAT FACILITATE ECONOMIC OPPORTUNITY  
AND ENHANCE QUALITY OF LIFE.**

**MAYOR LISA BROWN**

**COUNCIL PRESIDENT BETSY WILKERSON**

**COUNCIL MEMBER JONATHAN BINGLE**

**COUNCIL MEMBER PAUL DILLON**

**COUNCIL MEMBER LILI NAVARRETE**

**COUNCIL MEMBER MICHAEL CATHCART**

**COUNCIL MEMBER KITTY KLITZKE**

**COUNCIL MEMBER ZACK ZAPPONE**

**COUNCIL BRIEFING SESSION – 3:30 P.M.  
COUNCIL CHAMBERS  
CITY HALL, 808 W. SPOKANE FALLS BLVD.  
SPOKANE, WA 99201**

**TOWN HALL/LEGISLATIVE SESSION – 6:00 P.M.  
MLK JR. COMMUNITY CENTER  
500 S. STONE ST. – MULTI-PURPOSE ROOM  
SPOKANE, WA 99202**

## **LAND ACKNOWLEDGEMENT**

We acknowledge that we are on the unceded land of the Spokane people. And that these lands were once the major trading center for the Spokanes as they shared this place and welcomed other area tribes through their relations, history, trade, and ceremony. We also want to acknowledge that the land holds the spirit of the place, through its knowledge, culture, and all the original peoples Since Time Immemorial.

As we take a moment to consider the impacts of colonization may we also acknowledge the strengths and resiliency of the Spokanes and their relatives. As we work together making decisions that benefit all, may we do so as one heart, one mind, and one spirit.

We are grateful to be on the shared lands of the Spokane people and ask for the support of their ancestors and all relations. We ask that you recognize these injustices that forever changed the lives of the Spokane people and all their relatives.

We agree to work together to stop all acts of continued injustices towards Native Americans and all our relatives. It is time for reconciliation. We must act upon the truths and take actions that will create restorative justice for all people.

Adopted by Spokane City Council on the 22nd day of March, 2021  
*via Resolution 2021-0019*

## BRIEFING AND LEGISLATIVE SESSIONS

The Briefing Session is open to the public, but will be a workshop meeting. Discussion will be limited to Council Members and appropriate Staff and Counsel. The Legislative Session is also open to the public and public comment will be taken on Legislative Session items, except those that are adjudicatory or solely administrative in nature. Following the conclusion of the Legislative Agenda, an Open Forum will be held unless a majority of Council Members vote otherwise. Please see additional Open Forum information that appears at the end of the City Council agenda.

SPOKANE CITY COUNCIL BRIEFING SESSIONS (BEGINNING AT 3:30 P.M. EACH MONDAY) AND LEGISLATIVE SESSIONS (BEGINNING AT 6:00 P.M. EACH MONDAY) ARE BROADCAST LIVE ON CITY CABLE CHANNEL FIVE AND STREAMED LIVE ON THE CHANNEL FIVE WEBSITE. THE SESSIONS ARE REPLAYED ON CHANNEL FIVE ON THURSDAYS AT 6:00 P.M. AND FRIDAYS AT 10:00 A.M.

### ADDRESSING THE COUNCIL

- No member of the public may speak without first being recognized for that purpose by the Chair. Except for named parties to an adjudicative hearing, a person may be required to sign a sign-up sheet and provide their city of residence as a condition of recognition. Council Members must be recognized by the chair for the purpose of obtaining the floor.
- Each person speaking at the public microphone shall verbally identify themselves by name, city of residency and, if appropriate, representative capacity.
- Each speaker shall follow all written and verbal instructions so that verbal remarks are electronically recorded, and documents submitted for the record are identified and marked by the Clerk. (If you are submitting letters or documents to the Council Members, please provide a minimum of ten copies via the City Clerk. The City Clerk is responsible for officially filing and distributing your submittal.)
- In order that evidence and expressions of opinion be included in the record and that decorum befitting a deliberative process be maintained, no modes of expression including but not limited to demonstrations, banners, signs, applause, profanity, vulgar language, or personal insults will be permitted. To prevent disruption of council meetings and visual obstruction of proceedings, members of the audience shall remain seated during council meetings.
- A speaker asserting a statement of fact may be asked to document and identify the source of the factual datum being asserted.
- When addressing the Council, members of the public shall direct all remarks to the Council President, and shall confine their remarks to the matters that are specifically before the Council at that time or, if speaking during Open Forum, shall confine their remarks to affairs of the city.
- City staff may participate in public comment, including open forum, providing they are in compliance with the City of Spokane Code of Ethics and they follow the steps outlined in the City Council Rules of Procedure.

**SPEAKING TIME LIMITS:** Unless the time limit is adjusted by a majority vote of the Council, each person addressing the Council shall be limited to a two-minute speaking time during Open Forum and a three-minute speaking time for other matters. The chair may allow additional time if the speaker is asked to respond to questions from the Council. Public testimony and consideration of an item may be extended to a subsequent meeting by a majority vote of the Council. Note: No public testimony shall be taken on amendments to consent or legislative agenda items, or solely procedural, parliamentary, or administrative matters of the Council, including veto overrides.

**CITY COUNCIL AGENDA:** The City Council Advance and Current Agendas may be obtained prior to Council Meetings by accessing the City website at <https://my.spokanecity.org/citycouncil/documents/>.

# **BRIEFING SESSION**

**(3:30 p.m.)**

**(Council Chambers Lower Level of City Hall)  
(No Public Testimony Taken)**

**ROLL CALL OF COUNCIL**

**INTERVIEWS OF NOMINEES TO BOARDS AND COMMISSIONS**

**COUNCIL OR STAFF REPORTS OF MATTERS OF INTEREST**

**ADVANCE AGENDA REVIEW (Staff or Council Member briefings and discussion)**

**APPROVAL BY MOTION OF THE ADVANCE AGENDA**

**CURRENT AGENDA REVIEW (Presentation of any new background information and discussion of any adjustments)**

---

# **EXECUTIVE SESSION**

**(Closed Session of Council)**

**(Executive Session may be held or reconvened during the 6:00 p.m. Legislative Session)**

---

# **TOWN HALL / LEGISLATIVE SESSION**

**(6:00 P.M.)**

**(Council Reconvenes at MLK Jr. Community Center – 500 S. Stone St.  
Multi-Purpose Room)**

**PLEDGE OF ALLEGIANCE**

**WORDS OF INSPIRATION AND SPECIAL INTRODUCTIONS**

**ROLL CALL OF COUNCIL**

**PROCLAMATIONS AND SALUTATIONS**

**REPORTS FROM COMMUNITY ORGANIZATIONS**

**ANNOUNCEMENTS**

**(Announcements regarding Changes to the City Council Agenda)**



# BOARDS AND COMMISSIONS APPOINTMENTS

(Includes Announcements of Boards and Commissions Vacancies)

## APPOINTMENTS

## RECOMMENDATION

Ethics Commission: Three Appointments

Confirm

CPR 2006-0042

# NEIGHBORHOOD REPORTS

## CONSENT AGENDA

The consent agenda consists of purchases and contracts for supplies and services provided to the city, as well as other agreements that arise (such as settlement or union agreements), and weekly claims and payments of previously approved obligations and biweekly payroll claims against the city. Any agreement over \$50,000 must be approved by the city council. Typically, the funding to pay for these agreements has already been approved by the city council through the annual budget ordinance, or through a separate special budget ordinance. If the contract requires a new allocation of funds, that fact usually will be indicated in the summary of the contract in the consent agenda.

Unless a council member requests that an item be considered separately, the council approves the consent agenda as a whole in a single vote. Note: The consent agenda is no longer read in full by the city clerk. The public is welcome to testify on matters listed in the consent agenda, but individual testimony is limited to three minutes for the entire consent agenda.

## REPORTS, CONTRACTS AND CLAIMS

## RECOMMENDATION

- |  |                |               |
|--|----------------|---------------|
| 1. Value Blankets for the purchase of laboratory equipment and supplies for the Wastewater Management Department from June 1, 2024, through February 28, 2029, with: | Approve<br>All |               |
| a. Fisher Scientific Company, LLC—\$100,000.   |                | OPR 2024-0445 |
| b. Thomas Scientific—\$20,000.   |                | OPR 2024-0446 |
| c. VWR International, LLC—\$20,000.  |                | OPR 2024-0447 |

(Council Sponsors: Council President Wilkerson and Council Members Bingle and Klitzke)

**Kyle Arrington**

- |    |  |                |                              |
|----|--|----------------|------------------------------|
| 2. | Purchase from Western States Power Systems of a stationary generator to update the Upriver Hydroelectric back-up generator—\$107,149.18. (Council Sponsors: Council President Wilkerson and Council Members Bingle and Klitzke)<br><b>Seth McIntosh</b>  | Approve        | OPR 2024-0448                |
| 3. | Purchase from Ennis-Flint, Inc. (Greensboro, NC) of preformed thermoplastic for the Streets Department for five years beginning July 15, 2024—\$375,000. (\$75,000 annually.) (Council Sponsors: Council President Wilkerson and Council Members Bingle and Klitzke)<br><b>Clint Harris</b>                  | Approve        | OPR 2024-0449<br>ITB 6117-24 |
| 4. | Purchase from Zumar Industries, Inc. (Tacoma, WA) of perforated square steel tubing for the Streets Department for five years beginning August 1, 2024—\$500,000. (\$100,000 annually.) (Council Sponsors: Council President Wilkerson and Council Members Bingle and Klitzke)<br><b>Clint Harris</b>        | Approve        | OPR 2024-0450<br>ITB 6085-24 |
| 5. | Purchase from Western Systems, Inc. (Everett, WA) of rectangular rapid flashing beacons for the Streets Department for five years beginning on acceptance date—\$460,000. (\$92,000 annually.) (Council Sponsors: Council President Wilkerson and Council Members Bingle and Klitzke)<br><b>Clint Harris</b> | Approve        | OPR 2024-0451<br>ITB 6090-24 |
| 6. | Purchases of traffic paint the Streets Department for five years beginning July 15, 2024, from:  | Approve<br>All | ITB 6096-24                  |
|    | a. Ennis-Flint, Inc. (Greensboro, NC)  |                | OPR 2024-0452                |
|    | b. Aramsco, Inc. (Paulsboro, NJ)   |                | OPR 2024-0453                |
|    | Total cost across all vendors—\$750,000. (\$150,000 annually.) (Council Sponsors: Council President Wilkerson and Council Members Bingle and Klitzke)<br><b>Clint Harris</b>   |                |                              |
| 7. | Purchases of asphaltic mixes for multiple departments from June 2, 2024, through June 1, 2029, from:   | Approve<br>All | ITB 6098-24                  |
|    | a. Shamrock Paving, Inc. (Spokane)   |                | OPR 2024-0454                |
|    | b. Inland Asphalt Company (Spokane)  |                | OPR 2024-0455                |
|    | c. Poe Asphalt Paving, Inc. (Spokane)  |                | OPR 2024-0456                |

Total cost across all vendors—\$9,625,000. (\$1,925,000 annually.) (Council Sponsors: Council President Wilkerson and Council Members Bingle and Klitzke)

**Clint Harris**

- |  |                        |   |
|--|------------------------|---|
| <p>8. Value Blanket Renewal 2 of 3 with Hitachi Zosen Inova U.S.A. LLC (Norcross, GA) for the purchase of feeder and grate parts at the Waste to Energy Facility from July 1, 2024, through June 30, 2024—total cost not to exceed \$1,300,000 (plus tax). (Council Sponsors: Council President Wilkerson and Council Members Bingle and Klitzke)</p>  | <p>Approve</p>         | <p>OPR 2021-0301<br/>ITB 5383-21</p>    |
| <p><b>David Paine</b></p>  |                        |   |
| <p>9. Five-year Value Blanket with Fluid Controls and Components, Inc. (Richland, WA) for the as-needed purchase of valves and repair kits for the Waste to Energy Facility from June 10, 2024, through June 9, 2029—\$1,500,000 (plus tax). (\$300,000 annually). (Council Sponsors: Council President Wilkerson and Council Members Bingle and Klitzke)</p>                                      | <p>Approve</p>         | <p>OPR 2024-0457<br/>ITB 6079-24</p>    |
| <p><b>David Paine</b></p>  |                        |   |
| <p>10. Contract Amendment with cost with Bender CCP, Inc. (Portland, OR) for as-needed boiler feedwater pump services at the Waste to Energy Facility from September 1, 2023, through August 31, 2024—additional \$200,000 (due to unanticipated repairs). Total Contract Amount: \$300,000 (plus tax). (Council Sponsors: Council President Wilkerson and Council Members Bingle and Klitzke)</p> | <p>Approve</p>         | <p>OPR 2023-0896<br/>PW ITB 5918-23</p> |
| <p><b>David Paine</b></p>  |                        |   |
| <p>11. Five-year Value Blankets for the purchases of imported and domestic butterfly valves on an as-needed basis for the Water and Hydroelectric Services Department with:</p>  | <p>Approve<br/>All</p> | <p>ITB 6095-24</p>                      |
| <p>a. Consolidated Supply (Spokane)—estimated annual amount \$300,000 (incl. tax.)</p>   |                        | <p>OPR 2024-0458</p>                    |
| <p>b. American AVK (Minden, NV)—estimated annual amount \$300,000 (incl. tax.)</p>   |                        | <p>OPR 2024-0459</p>                    |
| <p>(Council Sponsors: Council Members Zappone, Bingle, and Klitzke)</p>  |                        |   |
| <p><b>Loren Searl</b></p>  |                        |   |
| <p>12. Contract Renewal with Shamrock Paving, Inc. (Spokane) for on-call paving services from July 1, 2024, through June 30, 2025—not to exceed \$250,000 annually (excluding tax). (Council Sponsors: Council Members Zappone, Bingle, and Klitzke)</p>   | <p>Approve</p>         | <p>OPR 2021-0447<br/>ITB 5439-21</p>    |

- |  |   |  |
|--|---|--|
| <p>13. Services Agreement with the University of Washington (Seattle, WA) towards expansion of the Spokane Fire Department Behavioral Response Unit program—\$100,000. (Relates to Special Budget Ordinance C36527) (Council Sponsors: Council Members Dillon, Cathcart, and Navarrete)<br/><b>Anne Raven</b></p>  | <p>Approve</p>                                  | <p>OPR 2024-0460</p>   |
| <p>14. Contract with Thomson Reuters (Toronto, Ontario, Canada) for Westlaw Legal Research for multiple departments from July 1, 2024, through June 30, 2029—\$353,622.25 (incl. tax). Funds will be encumbered annually. (Council Sponsors: Council President Wilkerson and Council Members Cathcart and Zappone)<br/><b>Michael Piccolo</b></p>                                | <p>Approve</p>                                  | <p>OPR 2024-0461</p>   |
| <p>15. Low Bid of (<u>to be determined at bid opening</u>) (<u>City, ST</u>) for Traffic Calming Cycle 11 project—\$_____. An administrative reserve of \$_____, which is 10% of the contract price, will be set aside. (Various Neighborhoods) (Council Sponsors: Council President Wilkerson and Council Members Bingle and Klitzke)<br/><b>Dan Buller</b></p>                 | <p>Approve</p>                                  | <p>OPR 2024-0462<br/>ENG 2021046<br/>ENG 2021047<br/>ENG 2021048</p> |
| <p>16. Consultant Agreement with Bureau Veritas Technical Assessments LLC (Elliott City, MD) for a detailed facility inventory and facility condition assessment of City Hall from June 17, 2024, through May 31, 2027—not to exceed \$60,385 (plus tax). (Council Sponsors: Council President Wilkerson and Council Members Bingle and Klitzke)<br/><b>Dave Steele</b></p>      | <p>Approve</p>                                  | <p>OPR 2024-0463<br/>RFQ 24-002</p>                                  |
| <p>17. Preventative Maintenance Agreement with Arrow Concrete &amp; Asphalt Specialties (Spokane Valley, WA) for 2024 off-street parking lot repair and maintenance from June 1, 2024, through May 31, 2025—not to exceed \$300,000 (plus tax, if applicable). (Council Sponsors: Council President Wilkerson and Council Members Bingle and Klitzke)<br/><b>Dave Steele</b></p> | <p>Approve</p>                                  | <p>OPR 2024-0464<br/>IPWQ 6104-24</p>                                |
| <p>18. Report of the Mayor of pending:</p> <p style="padding-left: 40px;">a. Claims and payments of previously approved obligations, including those of Parks and Library, through _____, 2024, total \$_____, with Parks and Library claims approved by their respective boards. Warrants excluding Parks and Library total \$_____.</p>  | <p>Approve &amp;<br/>Authorize<br/>Payments</p> | <p>CPR 2024-0002</p>   |

- b. Payroll claims of previously approved obligations through \_\_\_\_\_, 2024: \$\_\_\_\_\_. CPR 2024-0003
  
- 19. a. City Council Meeting Minutes: \_\_\_\_\_, 2024. Approve All CPR 2024-0013
  
- b. City Council Standing Committee Meeting Minutes \_\_\_\_\_, 2024.

## LEGISLATIVE AGENDA

### SPECIAL BUDGET ORDINANCES

(Require Five Affirmative, Recorded Roll Call Votes)

Ordinance C36527 amending Ordinance No. C36467 passed by the City Council November 27, 2023, and entitled, "An Ordinance adopting the Annual Budget of the City of Spokane for 2024, making appropriations to the various funds of the City of Spokane government for the fiscal year ending December 31, 2024, and providing it shall take effect immediately upon passage," and declaring an emergency and appropriating funds in:

**Fire/EMS fund**

- 1) Increase revenue by \$100,000.
  - A) Of the increased revenue, \$100,000 is provided by University of Washington solely for EMS services.
- 2) Increase appropriation by \$100,000.
  - A) Of the increased appropriation, \$100,000 is to be provided solely for vehicles.

(This action arises from agreement for the expansion of the Spokane Fire Department Behavioral Response Unit.) (Relates to Consent Agenda Item No. 13) (Council Sponsors: Council Members Dillon, Cathcart, and Navarrete)

**Anne Raven**

### NO EMERGENCY ORDINANCES

### NO RESOLUTIONS

### NO FINAL READING ORDINANCES

## **FIRST READING ORDINANCES**

**ORD C36528** Streamlining licensing requirements for entertainment facilities and all ages venues; repealing Sections 10.23A.040 and 10.23A.60 of the Spokane Municipal Code; amending Sections 04.04.020, 10.23A.020, 10.23A.030 and 10.70.100 of the Spokane Municipal Code. (Council Sponsors: Council President Wilkerson and Council Member Zappone)  
**Adam McDaniel**

**FURTHER ACTION DEFERRED**

---

## **NO SPECIAL CONSIDERATIONS**

---

## **NO HEARINGS**

---

## **OPEN FORUM**

At the conclusion of legislative business, the Council shall recess briefly and then hold an open public comment period for up to 20 (twenty) speakers, unless a majority of council members vote otherwise. Each speaker is limited to no more than two minutes. In order to participate in Open Forum, you must sign up beginning at 5:00 p.m. on the Friday immediately preceding the legislative session and ending at 6:00 p.m. on the date of the meeting via the virtual testimony form linked in the meeting packet (<https://my.spokanecity.org/citycouncil/documents/>) or in person outside council chambers beginning at 8:00 a.m. on the day of the legislative session. The virtual sign-up form can also be found here: <https://forms.gle/Vd7n381x3seaL1NW6>. (If you are unable to access the form by clicking the hyperlink, please copy and paste the link address into your browser window.) Speakers must sign themselves in using a name. The individuals assigned to the twenty (20) spaces available will be chosen at random, with preference given to individuals who have not spoken at open forum during that calendar month. Instructions for virtual participation are provided on the form when you sign up. The Open Forum is a limited public forum; all matters discussed in the open forum shall relate to the affairs of the City other than items appearing on the Current or Advance Agendas, pending hearing items, and initiatives or referenda in a pending election. Individuals speaking during the open forum shall address their comments to the Council President and shall not use profanity, engage in obscene speech, or make personal comment or verbal insults about any individual.

---

**Motion to Approve Advance Agenda for June 10, 2024  
(per Council Rule 2.1.B)**

---

## **ADJOURNMENT**

The June 10, 2024, Regular Legislative Session of the City Council will be held and is adjourned to June 24, 2024.

**NOTE:** There is no meeting scheduled for June 17, 2024, as the meeting has been canceled in recognition of Juneteenth Week.

---

**AMERICANS WITH DISABILITIES ACT (ADA) INFORMATION:** The City of Spokane is committed to providing equal access to its facilities, programs and services for persons with disabilities. The Spokane City Council Chamber in the lower level of Spokane City Hall, 808 W. Spokane Falls Blvd., is wheelchair accessible and also is equipped with an infrared assistive listening system for persons with hearing loss. Headsets may be checked out (upon presentation of picture I.D.) at the City Cable 5 Production Booth located on the First Floor of the Municipal Building, directly above the Chase Gallery or through the meeting organizer. Individuals requesting reasonable accommodations or further information may call, write, or email Risk Management at 509.625.6221, 808 W. Spokane Falls Blvd, Spokane, WA, 99201; or [mlowmaster@spokanecity.org](mailto:mlowmaster@spokanecity.org). Persons who are deaf or hard of hearing may contact Risk Management through the Washington Relay Service at 7-1-1. Please contact us forty-eight (48) hours before the meeting date.

---

## **NOTES**



**Agenda Sheet for City Council:**

**Committee:** **Date:** N/A

**Committee Agenda type:**

**Council Meeting Date:** 06/10/2024

**Date Rec'd**

5/29/2024

**Clerk's File #**

CPR 2006-0042

**Cross Ref #**

**Project #**

**Submitting Dept**

MAYOR

**Bid #**

**Contact Name/Phone**

ADAM 6779

**Requisition #**

**Contact E-Mail**

AMCDANIEL@SPOKANECITY.ORG

**Agenda Item Type**

Boards and Commissions

**Council Sponsor(s)**

**Agenda Item Name**

APPOINTMENT OF MELANIE MEAGHER TO THE ETHICS COMMISSION

**Agenda Wording**

Mayor Brown has appointed Melanie Meagher to the Ethics Commission for a term of June 17, 2024 - June 17, 2027.

**Summary (Background)**

The Spokane City Council adopted the City's Code of Ethics in January of 2006 (Ordinance No. C-33785) and updated the Code of Ethics with the recognition of the Ethics Commission through the adoption of Ordinance No. C-35148 in January of 2015. The City's Code of Ethics is set forth in Chapter 1.04A of the Spokane Municipal Code and is applicable to elected and appointed officials, exempt-confidential employees and represented employees pursuant to applicable collective bargaining agreements.

Lease? NO

Grant related? NO

Public Works? NO

**Fiscal Impact**

Approved in Current Year Budget? N/A

Total Cost

\$

Current Year Cost

\$

Subsequent Year(s) Cost

\$

**Narrative**

**Amount**

**Budget Account**

Select

\$

#

Select

\$

#

Select

\$

#

Select

\$

#

\$

#

\$

#





**Continuation of Wording, Summary, Approvals, and Distribution**

**Agenda Wording**

**Summary (Background)**

**Approvals**

**Dept Head**

JONES, GARRETT

**Division Director**

**Accounting Manager**

**Legal**

**For the Mayor**

JONES, GARRETT

**Additional Approvals**

**Distribution List**

amcdaniel@spokanecity.org

## Committee Agenda Sheet

### \*Select Committee Name\*

<b>Committee Date</b>	June 17, 2024
<b>Submitting Department</b>	Mayor's Office
<b>Contact Name</b>	Adam McDaniel
<b>Contact Email &amp; Phone</b>	<a href="mailto:amcdaniel@spokanecity.org">amcdaniel@spokanecity.org</a>   625-6779
<b>Council Sponsor(s)</b>	Please enter the name of the Council Sponsor(s)
<b>Select Agenda Item Type</b>	<input type="checkbox"/> Consent <input type="checkbox"/> Discussion    Time Requested:
<b>Agenda Item Name</b>	Appointment of Melanie Meagher to the Ethics Commission
<b>Proposed Council Action</b>	<input checked="" type="checkbox"/> Approval to proceed to Legislative Agenda <input type="checkbox"/> Information Only
<b>Summary (Background)</b>  *use the Fiscal Impact box below for relevant financial information	<p>Mayor Brown has appointed Melanie Meagher to the Ethics Commission for a term of June 17, 2024 – June 17, 2027.</p> <p>The Spokane City Council adopted the City's Code of Ethics in January of 2006 (Ordinance No. C-33785) and updated the Code of Ethics with the recognition of the Ethics Commission through the adoption of Ordinance No. C-35148 in January of 2015. The City's Code of Ethics is set forth in Chapter 1.04A of the Spokane Municipal Code and is applicable to elected and appointed officials, exempt-confidential employees and represented employees pursuant to applicable collective bargaining agreements.</p> <p>Per SMC 01.04A.080, the Ethics Commission is comprised of seven members appointed by the mayor and confirmed by the city council. The Ethics Commission appointees should include representatives from the following segments of the community:</p> <ol style="list-style-type: none"> <li>1. A person with a professional or academic background in the legal profession including attorneys, law professors or members of the judiciary.</li> <li>2. A person from local business with experience in human resources/personnel.</li> <li>3. A person who possesses familiarity with government and the political process.</li> <li>4. A person with experience in ethics.</li> </ol>
<b>Fiscal Impact</b> <b>Approved in current year budget?</b> <input type="checkbox"/> Yes <input type="checkbox"/> No <input checked="" type="checkbox"/> N/A Total Cost: <small>Click or tap here to enter text.</small> Current year cost: Subsequent year(s) cost:	
<b>Narrative:</b> Please provide financial due diligence review, as applicable, such as number and type of positions, grant match requirements, summary type details (personnel, maintenance and supplies, capital, revenue), impact on rates, fees, or future shared revenue	
<b>Funding Source</b> <input type="checkbox"/> One-time <input type="checkbox"/> Recurring <input checked="" type="checkbox"/> N/A Specify funding source: Select Funding Source*	

Is this funding source sustainable for future years, months, etc? [Click or tap here to enter text.](#)

**Expense Occurrence**    One-time    Recurring    N/A

Other budget impacts: (revenue generating, match requirements, etc.)

**Operations Impacts** (If N/A, please give a brief description as to why)

What impacts would the proposal have on historically excluded communities?

N/A

How will data be collected, analyzed, and reported concerning the effect of the program/policy by racial, ethnic, gender identity, national origin, income level, disability, sexual orientation, or other existing disparities?

N/A

How will data be collected regarding the effectiveness of this program, policy or product to ensure it is the right solution?

N/A

Describe how this proposal aligns with current City Policies, including the Comprehensive Plan, Sustainability Action Plan, Capital Improvement Program, Neighborhood Master Plans, Council Resolutions, and others?

This appointment aligns with the requirements of SMC 01.04A.080



# Agenda Sheet for City Council:

Committee: Date: N/A

Committee Agenda type:

**Date Rec'd**

5/29/2024

**Clerk's File #**

CPR 2006-0042

**Cross Ref #**

**Project #**

**Council Meeting Date:** 06/10/2024

**Submitting Dept**

MAYOR

**Bid #**

**Contact Name/Phone**

ADAM 6779

**Requisition #**

**Contact E-Mail**

AMCDANIEL@SPOKANECITY.ORG

**Agenda Item Type**

Boards and Commissions

**Council Sponsor(s)**

**Agenda Item Name**

APPOINTMENT OF LISA DRAKE TO THE ETHICS COMMISSION

## **Agenda Wording**

Mayor Brown has appointed Lisa Drake to the Ethics Commission for a term of June 17, 2024 - June 17, 2027.

## **Summary (Background)**

The Spokane City Council adopted the City's Code of Ethics in January of 2006 (Ordinance No. C-33785) and updated the Code of Ethics with the recognition of the Ethics Commission through the adoption of Ordinance No. C-35148 in January of 2015. The City's Code of Ethics is set forth in Chapter 1.04A of the Spokane Municipal Code and is applicable to elected and appointed officials, exempt-confidential employees and represented employees pursuant to applicable collective bargaining agreements.

Lease? NO

Grant related? NO

Public Works? NO

## **Fiscal Impact**

Approved in Current Year Budget? N/A

Total Cost

\$

Current Year Cost

\$

Subsequent Year(s) Cost

\$

## **Narrative**

### **Amount**

### **Budget Account**

Select

\$

#

Select

\$

#

Select

\$

#

Select

\$

#

\$

#

\$

#



**Continuation of Wording, Summary, Approvals, and Distribution**

**Agenda Wording**

**Summary (Background)**

**Approvals**

**Dept Head**

JONES, GARRETT

**Additional Approvals**

**Division Director**

**Accounting Manager**

**Legal**

**For the Mayor**

JONES, GARRETT

**Distribution List**

amcdaniel@spokanecity.org

## Committee Agenda Sheet

### \*Select Committee Name\*

<b>Committee Date</b>	June 17, 2024
<b>Submitting Department</b>	Mayor's Office
<b>Contact Name</b>	Adam McDaniel
<b>Contact Email &amp; Phone</b>	<a href="mailto:amcdaniel@spokanecity.org">amcdaniel@spokanecity.org</a>   625-6779
<b>Council Sponsor(s)</b>	Please enter the name of the Council Sponsor(s)
<b>Select Agenda Item Type</b>	<input type="checkbox"/> Consent <input type="checkbox"/> Discussion    Time Requested:
<b>Agenda Item Name</b>	Appointment of Lisa Drake to the Ethics Commission
<b>Proposed Council Action</b>	<input checked="" type="checkbox"/> Approval to proceed to Legislative Agenda <input type="checkbox"/> Information Only
<b>Summary (Background)</b>  *use the Fiscal Impact box below for relevant financial information	<p>Mayor Brown has appointed Lisa Drake to the Ethics Commission for a term of June 17, 2024 – June 17, 2027.</p> <p>The Spokane City Council adopted the City's Code of Ethics in January of 2006 (Ordinance No. C-33785) and updated the Code of Ethics with the recognition of the Ethics Commission through the adoption of Ordinance No. C-35148 in January of 2015. The City's Code of Ethics is set forth in Chapter 1.04A of the Spokane Municipal Code and is applicable to elected and appointed officials, exempt-confidential employees and represented employees pursuant to applicable collective bargaining agreements.</p> <p>Per SMC 01.04A.080, the Ethics Commission is comprised of seven members appointed by the mayor and confirmed by the city council. The Ethics Commission appointees should include representatives from the following segments of the community:</p> <ol style="list-style-type: none"> <li>1. A person with a professional or academic background in the legal profession including attorneys, law professors or members of the judiciary.</li> <li>2. A person from local business with experience in human resources/personnel.</li> <li>3. A person who possesses familiarity with government and the political process.</li> <li>4. A person with experience in ethics.</li> </ol>
<b>Fiscal Impact</b>	
<b>Approved in current year budget?</b> <input type="checkbox"/> Yes <input type="checkbox"/> No <input checked="" type="checkbox"/> N/A	
Total Cost: <small>Click or tap here to enter text.</small>	
Current year cost:	
Subsequent year(s) cost:	
<b>Narrative:</b> Please provide financial due diligence review, as applicable, such as number and type of positions, grant match requirements, summary type details (personnel, maintenance and supplies, capital, revenue), impact on rates, fees, or future shared revenue	
<b>Funding Source</b> <input type="checkbox"/> One-time <input type="checkbox"/> Recurring <input checked="" type="checkbox"/> N/A	
Specify funding source: Select Funding Source*	

Is this funding source sustainable for future years, months, etc? [Click or tap here to enter text.](#)

**Expense Occurrence**    One-time    Recurring    N/A

Other budget impacts: (revenue generating, match requirements, etc.)

**Operations Impacts** (If N/A, please give a brief description as to why)

What impacts would the proposal have on historically excluded communities?

N/A

How will data be collected, analyzed, and reported concerning the effect of the program/policy by racial, ethnic, gender identity, national origin, income level, disability, sexual orientation, or other existing disparities?

N/A

How will data be collected regarding the effectiveness of this program, policy or product to ensure it is the right solution?

N/A

Describe how this proposal aligns with current City Policies, including the Comprehensive Plan, Sustainability Action Plan, Capital Improvement Program, Neighborhood Master Plans, Council Resolutions, and others?

This appointment aligns with the requirements of SMC 01.04A.080



**Agenda Sheet for City Council:**

**Committee:** **Date:** N/A

**Committee Agenda type:**

**Date Rec'd**

5/29/2024

**Clerk's File #**

CPR 2006-0042

**Cross Ref #**

**Project #**

**Council Meeting Date:** 06/10/2024

**Submitting Dept**

MAYOR

**Bid #**

**Contact Name/Phone**

ADAM 6779

**Requisition #**

**Contact E-Mail**

AMCDANIEL@SPOKANECITY.ORG

**Agenda Item Type**

Boards and Commissions

**Council Sponsor(s)**

**Agenda Item Name**

APPOINTMENT OF MAGGIE APROBERTS-WARREN TO THE ETHICS

**Agenda Wording**

Mayor Brown has appointed Maggie apRoberts-Warren to the Ethics Commission for a term of June 17, 2024 - June 17, 2027.

**Summary (Background)**

The Spokane City Council adopted the City's Code of Ethics in January of 2006 (Ordinance No. C-33785) and updated the Code of Ethics with the recognition of the Ethics Commission through the adoption of Ordinance No. C-35148 in January of 2015. The City's Code of Ethics is set forth in Chapter 1.04A of the Spokane Municipal Code and is applicable to elected and appointed officials, exempt-confidential employees and represented employees pursuant to applicable collective bargaining agreements.

Lease? NO

Grant related? NO

Public Works? NO

**Fiscal Impact**

Approved in Current Year Budget? N/A

Total Cost

\$

Current Year Cost

\$

Subsequent Year(s) Cost

\$

**Narrative**

**Amount**

**Budget Account**

Select

\$

#

Select

\$

#

Select

\$

#

Select

\$

#

\$

#

\$

#





**Continuation of Wording, Summary, Approvals, and Distribution**

**Agenda Wording**

**Summary (Background)**

**Approvals**

**Dept Head**

JONES, GARRETT

**Additional Approvals**

**Division Director**

**Accounting Manager**

**Legal**

**For the Mayor**

JONES, GARRETT

**Distribution List**

amcdaniel@spokanecity.org

## Committee Agenda Sheet

### \*Select Committee Name\*

<b>Committee Date</b>	June 17, 2024
<b>Submitting Department</b>	Mayor's Office
<b>Contact Name</b>	Adam McDaniel
<b>Contact Email &amp; Phone</b>	<a href="mailto:amcdaniel@spokanecity.org">amcdaniel@spokanecity.org</a>   625-6779
<b>Council Sponsor(s)</b>	Please enter the name of the Council Sponsor(s)
<b>Select Agenda Item Type</b>	<input type="checkbox"/> Consent <input type="checkbox"/> Discussion    Time Requested:
<b>Agenda Item Name</b>	Appointment of Maggie apRoberts-Warren to the Ethics Commission
<b>Proposed Council Action</b>	<input checked="" type="checkbox"/> Approval to proceed to Legislative Agenda <input type="checkbox"/> Information Only
<b>Summary (Background)</b>  *use the Fiscal Impact box below for relevant financial information	<p>Mayor Brown has appointed Maggie apRoberts-Warren to the Ethics Commission for a term of June 17, 2024 – June 17, 2027.</p> <p>The Spokane City Council adopted the City's Code of Ethics in January of 2006 (Ordinance No. C-33785) and updated the Code of Ethics with the recognition of the Ethics Commission through the adoption of Ordinance No. C-35148 in January of 2015. The City's Code of Ethics is set forth in Chapter 1.04A of the Spokane Municipal Code and is applicable to elected and appointed officials, exempt-confidential employees and represented employees pursuant to applicable collective bargaining agreements.</p> <p>Per SMC 01.04A.080, the Ethics Commission is comprised of seven members appointed by the mayor and confirmed by the city council. The Ethics Commission appointees should include representatives from the following segments of the community:</p> <ol style="list-style-type: none"> <li>1. A person with a professional or academic background in the legal profession including attorneys, law professors or members of the judiciary.</li> <li>2. A person from local business with experience in human resources/personnel.</li> <li>3. A person who possesses familiarity with government and the political process.</li> <li>4. A person with experience in ethics.</li> </ol>
<b>Fiscal Impact</b>	
<b>Approved in current year budget?</b> <input type="checkbox"/> Yes <input type="checkbox"/> No <input checked="" type="checkbox"/> N/A	
Total Cost: <small>Click or tap here to enter text.</small>	
Current year cost:	
Subsequent year(s) cost:	
<b>Narrative:</b> Please provide financial due diligence review, as applicable, such as number and type of positions, grant match requirements, summary type details (personnel, maintenance and supplies, capital, revenue), impact on rates, fees, or future shared revenue	
<b>Funding Source</b> <input type="checkbox"/> One-time <input type="checkbox"/> Recurring <input checked="" type="checkbox"/> N/A	
Specify funding source: Select Funding Source*	

Is this funding source sustainable for future years, months, etc? [Click or tap here to enter text.](#)

**Expense Occurrence**    One-time    Recurring    N/A

Other budget impacts: (revenue generating, match requirements, etc.)

**Operations Impacts** (If N/A, please give a brief description as to why)

What impacts would the proposal have on historically excluded communities?

N/A

How will data be collected, analyzed, and reported concerning the effect of the program/policy by racial, ethnic, gender identity, national origin, income level, disability, sexual orientation, or other existing disparities?

N/A

How will data be collected regarding the effectiveness of this program, policy or product to ensure it is the right solution?

N/A

Describe how this proposal aligns with current City Policies, including the Comprehensive Plan, Sustainability Action Plan, Capital Improvement Program, Neighborhood Master Plans, Council Resolutions, and others?

This appointment aligns with the requirements of SMC 01.04A.080

**Agenda Sheet for City Council:****Committee:** PIES **Date:** 05/20/2024**Committee Agenda type:** Consent**Date Rec'd**

5/20/2024

**Clerk's File #**

OPR 2024-0445

**Cross Ref #**

OPR 2024-0446

**Cross Ref #**

OPR 2024-0447

**Council Meeting Date:** 06/10/2024**Submitting Dept**

WASTEWATER MANAGEMENT

**Bid #****Contact Name/Phone**

KYLE 625-4647

**Requisition #**

VALUE BLANKET

**Contact E-Mail**

KARRINGTON@SPOKANECITY.ORG

**Agenda Item Type**

Purchase w/o Contract

**Council Sponsor(s)**

BWILKERSON JBINGLE KKLITZKE

**Agenda Item Name**

4320 LAB SUPPLIES VALUE BLANKETS - MULTIPLE VENDORS

**Agenda Wording**

Value Blankets with multiple vendors for like Lab Supplies for the period of 06/01/2024 to 02/28/2029, total cost annually for all vendors is \$140,000.00 including tax.

OPR 2024-0445 - Fisher Scientific Company LLC

**Summary (Background)**

We are awarding to multiple vendors for like items. Together these vendors' equipment and supplies exceed the agenda threshold. This has been competed with DES and they are all accessing the same state contract. Contract number 20722 (Laboratory Equipment and Supplies) We are awarding value blankets to the following due to their state contracts. A. Fisher Scientific Company, LLC \$100,000.00 B. Thomas Scientific \$20,000.00 C. VWR International, LLC \$20,000.00 The time period is 06/01/2024 to 02/28/2029

Lease? NO

Grant related? NO

Public Works? NO

**Fiscal Impact**

Approved in Current Year Budget? YES

Total Cost \$ 140,000.00

Current Year Cost \$ 140,000.00

Subsequent Year(s) Cost \$ 140,000.00

**Narrative**

Value blankets set up to purchase required lab supplies.

**Amount****Budget Account**

Expense \$ 140,000.00

# 4320.43260.35148.53201

Select \$

#

Select \$

#

Select \$

#

\$

#

\$

#



## Continuation of Wording, Summary, Approvals, and Distribution

### Agenda Wording

### Summary (Background)

#### **Approvals**

##### Dept Head

GENNETT, RAYLENE

##### Division Director

FEIST, MARLENE

##### Accounting Manager

ALBIN-MOORE, ANGELA

##### Legal

HARRINGTON,

##### For the Mayor

JONES, GARRETT

#### **Additional Approvals**

#### **Distribution List**

	hbarnhart@spokanecity.org
kkeck@spokanecity.org	mmurray@spokanecity.org
Tax & Licenses	rpwrfaccounting@spokanecity.org
tlester@spokancity.org	

## Committee Agenda Sheet

### Public Infrastructure, Environment & Sustainability Committee

<b>Committee Date</b>	May 20 <sup>th</sup> , 2024
<b>Submitting Department</b>	Wastewater Management/RPWRF
<b>Contact Name</b>	Kyle Arrington
<b>Contact Email &amp; Phone</b>	<a href="mailto:karrington@spokanecity.org">karrington@spokanecity.org</a>
<b>Council Sponsor(s)</b>	CP Wilkerson, CM Bingle, CM Klitzke
<b>Select Agenda Item Type</b>	<input checked="" type="checkbox"/> Consent <input type="checkbox"/> Discussion    Time Requested:
<b>Agenda Item Name</b>	Lab Supplies – Value Blankets – multiple Vendors
<b>Proposed Council Action</b>	<input checked="" type="checkbox"/> Approval to proceed to Legislative Agenda <input type="checkbox"/> Information Only
<b>Summary (Background)</b>  *use the Fiscal Impact box below for relevant financial information	<p>We are awarding to multiple vendors for like items. Together these vendors' equipment and supplies exceed the agenda threshold. This has been competed with DES and they are all accessing the same state contract. Contract number 20722 (Laboratory Equipment and Supplies) We are awarding value blankets to the following due to their state contracts.</p> <ul style="list-style-type: none"> <li>A. Fisher Scientific Company, LLC \$100,000.00</li> <li>B. Thomas Scientific \$20,000.00</li> <li>C. VWR International, LLC \$20,000.00</li> </ul> <p>The time period is 06/01/2024 to 02/28/2029</p>

**Fiscal Impact**

**Approved in current year budget?**     Yes     No     N/A

Total Cost: \$140,000.00

Current year cost: \$140,000.00

Subsequent year(s) cost: \$140,000.00

**Narrative:** A. \$100,000.00 per year – Fisher B. \$20,000.00 per year – Thomas Scientific C. \$20,000.00 per year – VWR

**Funding Source**     One-time     Recurring     N/A

Specify funding source: Program revenue

Is this funding source sustainable for future years, months, etc? Yes, Operating Budget

**Expense Occurrence**     One-time     Recurring     N/A

Other budget impacts: (revenue generating, match requirements, etc.)

**Operations Impacts (If N/A, please give a brief description as to why)**

- What impacts would the proposal have on historically excluded communities?  
Public works services and projects are designed to serve all citizens and businesses. We strive to offer a consistent level of service to all, to distribute public investment throughout the community and to respond to gaps in services identified in various City plans.
- How will data be collected, analyzed, and reported concerning the effect of the program/policy by racial, ethnic, gender identity, national origin, income level, disability, sexual orientation, or other existing disparities?  
N/A
- How will data be collected regarding the effectiveness of this program, policy, or product to ensure it is the right solution?  
Public Works follows the City's established procurement and public works bidding regulations and policies to bring items forward, and then uses contract management best practices to ensure desired outcomes and regulatory compliance.
- Describe how this proposal aligns with current City Policies, including the Comprehensive Plan, Sustainability Action Plan, Capital Improvement Program, Neighborhood Master Plans, Council Resolutions, and others?  
This work is consistent with annual budget strategies to limit costs and approved projects in the 6-year CIP.

**Council Subcommittee Review**

- Please provide a summary of council subcommittee review. If not reviewed by a council subcommittee, please explain why not.

# Contract Summary

## Laboratory Equipment and Supplies



[See vendors on this contract and their certifications](#)

Contract #: 20722

Replaces: [07215](#)

Contract Type: COOPERATIVE

### Contract Scope

The Department of Enterprise Services (DES), through partnership with NASPO ValuePoint, offers this contract as solicited by the state of Idaho for the purchase of laboratory equipment and supplies. State agencies, higher education, and political subdivisions are eligible to utilize this contract.

### Products Included

- Fisher Scientific Company - Full-line Catalog of Laboratory Equipment and Supplies
- Nikon Instruments Inc. - Microscopes and Accessories
- Thomas Scientific - Full-line Catalog of Laboratory Equipment and Supplies
- VWR International, LLC - Full-line Catalog of Laboratory Equipment and Supplies, Microscopes and Accessories

### How to Use this Contract

1. Select the 'Product Pricing' link below for the contractor of your choice to find downloadable product and pricing documents (right lower corner, under 'Documents/Details').
2. Contact the applicable sales representative directly to consult about their products and/or to place an order.
3. Reference State Contract No. 20722 on your purchase order.
4. Contact the Contract Administrator(s) listed below with any further questions.

### Awarded Contractors

#### Fisher Scientific Company, LLC

*Brian Gill*

[brian.gill@thermofisher.com](mailto:brian.gill@thermofisher.com)

(412) 657-1383

[Product Pricing](#)

#### Nikon Instruments Inc.

*Jacquelyn Perry*

[niiorderscontacts@nikon.net](mailto:niiorderscontacts@nikon.net)

(631) 547-8526

[Product Pricing](#)

#### Thomas Scientific

*Lewis McMillan*

[lewis.mcmillan@thomasci.com](mailto:lewis.mcmillan@thomasci.com)

(484) 280-8133

[Product Pricing](#)

#### VWR International, LLC

*Rebecca Richey*



[rebecca.richey@avantorsciences.com](mailto:rebecca.richey@avantorsciences.com)

(949) 510-4566

[Product Pricing](#)

DES has ensured this procurement meets [RCW 39.26](#), follows State of Washington [Current Procurement Policies](#), [follows DES procurement process](#), and DES has determined that entering into this contract will be in the best interest of the State of Washington.

**Found a Broken Link? [E-mail DES](#) so we can fix it ASAP.**

Effective Date: 03-01-2024

Est. Annual Worth: \$6,000,000

Current Term Ends On: 02-28-2029

Final Term Ends On:

Commodity Code(s): 260-02, 220-02, 680-02, 928-04, 495-05, 220-04, 271-08, 495-07, 493-04, 493-05, 470-06, 710-09, 928-10, 260-04, 470-10, 740-05, 495-08, 465-01, 690-14, 470-13, 465-02, 875-05, 271-10, 260-01, 465-03, 875-09, 495-09, 495-10

Diversity: 0% WBE 0% MBE

# of Bids Received:

Contact Info: Samantha Johnson ☎ (360) 790-9507

✉ [samantha.johnson@des.wa.gov](mailto:samantha.johnson@des.wa.gov)

Secondary Contact Nick Ioanna ☎ (360) 790-4257

Info:  
✉ [nicholas.ioanna@des.wa.gov](mailto:nicholas.ioanna@des.wa.gov)

Who Can Use This Contract?

- [Organizations with Statewide Contract Usage Agreements](#)
- [Customer Communication Profile](#)

>>>> [Vendor and Contract Performance Feedback Form](#)

>>>> Please send an email request to the Contract Manager for copies of any submitted feedback

- Amendment 1 - Fisher Scientific
- NASPO Contract - Fisher Scientific
- NASPO Contract - Nikon
- NASPO Contract - Thomas Scientific
- NASPO Contract - VWR
- Participating Addendum - Fisher Scientific
- Participating Addendum - Nikon
- Participating Addendum - Thomas Scientific
- Participating Addendum - VWR
  
- Original Solicitation
- Bid Tabulation

*This Contract has no Resource Documents*

### Showing 1 to 4 of 4 Vendors









All ▾ Vendors Per Page.

Search Vendors:

Vendor <span>↑↓</span>	Vendor # <span>↑↓</span>	OMWBE <span>↑↓</span>	Small Business <span>↑↓</span>	Veteran <span>↑↓</span>	Considerations / Preferences <span>↑↓</span>	Award Type <span>↑↓</span>
FISHER SCIENTIFIC, LLC	W2405					Main
NIKON INSTRUMENTS INC	W14809					Main
THOMAS SCIENTIFIC, LLC	W68935					Main
VWR INTERNATIONAL, LLC	W1692					Main



M = OMWBE Certified Minority Owned | W = OMWBE Certified Women Owned | MW = OMWBE Certified Minority Women Owned

[Award Types = Main, Reserved, and Main/Reserved](#)

-  = Veteran Owned
-  = Small Business
-  = [Preference Contract w/ Green Recycled Content](#)
-  = [\\*Preference Executive Order 18-03](#)
-  = [\\*Preference Electronic Products Purchasing](#)
-  = [\\*Preference Hydrofluorocarbons Products Purchasing](#)
-  = [\\*Preference Nonmercury-Added Products Purchasing](#)
-  = [\\*Preference Polychlorinated Biphenyls \(PCBs\) Purchasing](#)
- \* = Newly Added Icon.
-  = [All Other Green Considerations](#)

### Didn't find what you were looking for?

The Contracts Resource Center is here to help.

-  (360) 407-2210
-  [contractingandpurchasing@des.wa.gov](mailto:contractingandpurchasing@des.wa.gov)
-  [Find a Contracts Specialist](#)

**Agenda Sheet for City Council:****Committee:** PIES **Date:** 05/20/2024**Committee Agenda type:** Consent**Date Rec'd**

5/20/2024

**Clerk's File #**

OPR 2024-0446

**Cross Ref #**

OPR 2024-0445

**Cross Ref #**

OPR 2024-0447

**Council Meeting Date:** 06/10/2024**Submitting Dept**

WASTEWATER MANAGEMENT

**Bid #****Contact Name/Phone**

KYLE 625-4647

**Requisition #**

VALUE BLANKET

**Contact E-Mail**

KARRINGTON@SPOKANECITY.ORG

**Agenda Item Type**

Purchase w/o Contract

**Council Sponsor(s)**

BWILKERSON JBINGLE KKLITZKE

**Agenda Item Name**

4320 LAB SUPPLIES VALUE BLANKETS - MULTIPLE VENDORS

**Agenda Wording**

Value Blankets with multiple vendors for like Lab Supplies for the period of 06/01/2024 to 02/28/2029, total cost annually for all vendors is \$140,000.00 including tax.

OPR 2024-0446 - Thomas Scientific

**Summary (Background)**

We are awarding to multiple vendors for like items. Together these vendors' equipment and supplies exceed the agenda threshold. This has been competed with DES and they are all accessing the same state contract. Contract number 20722 (Laboratory Equipment and Supplies) We are awarding value blankets to the following due to their state contracts. A. Fisher Scientific Company, LLC \$100,000.00 B. Thomas Scientific \$20,000.00 C. VWR International, LLC \$20,000.00 The time period is 06/01/2024 to 02/28/2029

Lease? NO

Grant related? NO

Public Works? NO

**Fiscal Impact**

Approved in Current Year Budget? YES

Total Cost \$ 140,000.00

Current Year Cost \$ 140,000.00

Subsequent Year(s) Cost \$ 140,000.00

**Narrative**

Value blankets set up to purchase required lab supplies.

**Amount****Budget Account**

Expense \$ 140,000.00

# 4320.43260.35148.53201

Select \$

#

Select \$

#

Select \$

#

\$

#

\$

#



**Continuation of Wording, Summary, Approvals, and Distribution**

**Agenda Wording**

**Summary (Background)**

**Approvals**

**Dept Head**

GENNETT, RAYLENE

**Division Director**

FEIST, MARLENE

**Accounting Manager**

ALBIN-MOORE, ANGELA

**Legal**

HARRINGTON,

**For the Mayor**

JONES, GARRETT

**Additional Approvals**

**Distribution List**

hbarnhart@spokanecity.org

kkeck@spokanecity.org

mmurray@spokanecity.org

Tax & Licenses

rpwrfaccounting@spokanecity.org

tlester@spokancity.org

## Committee Agenda Sheet

### Public Infrastructure, Environment & Sustainability Committee

<b>Committee Date</b>	May 20 <sup>th</sup> , 2024
<b>Submitting Department</b>	Wastewater Management/RPWRF
<b>Contact Name</b>	Kyle Arrington
<b>Contact Email &amp; Phone</b>	<a href="mailto:karrington@spokanecity.org">karrington@spokanecity.org</a>
<b>Council Sponsor(s)</b>	CP Wilkerson, CM Bingle, CM Klitzke
<b>Select Agenda Item Type</b>	<input checked="" type="checkbox"/> Consent <input type="checkbox"/> Discussion    Time Requested:
<b>Agenda Item Name</b>	Lab Supplies – Value Blankets – multiple Vendors
<b>Proposed Council Action</b>	<input checked="" type="checkbox"/> Approval to proceed to Legislative Agenda <input type="checkbox"/> Information Only
<b>Summary (Background)</b>  *use the Fiscal Impact box below for relevant financial information	<p>We are awarding to multiple vendors for like items. Together these vendors' equipment and supplies exceed the agenda threshold. This has been competed with DES and they are all accessing the same state contract. Contract number 20722 (Laboratory Equipment and Supplies) We are awarding value blankets to the following due to their state contracts.</p> <ul style="list-style-type: none"> <li>A. Fisher Scientific Company, LLC \$100,000.00</li> <li>B. Thomas Scientific \$20,000.00</li> <li>C. VWR International, LLC \$20,000.00</li> </ul> <p>The time period is 06/01/2024 to 02/28/2029</p>
<b>Fiscal Impact</b>	
<b>Approved in current year budget?</b> <input checked="" type="checkbox"/> Yes <input type="checkbox"/> No <input type="checkbox"/> N/A Total Cost: <u>\$140,000.00</u> Current year cost: \$140,000.00 Subsequent year(s) cost: \$140,000.00	
<b>Narrative:</b> <u>A.</u> \$100,000.00 per year – Fisher <u>B.</u> \$20,000.00 per year – Thomas Scientific <u>C.</u> \$20,000.00 per year – VWR	
<b>Funding Source</b> <input type="checkbox"/> One-time <input checked="" type="checkbox"/> Recurring <input type="checkbox"/> N/A Specify funding source: Program revenue Is this funding source sustainable for future years, months, etc? Yes, Operating Budget	
<b>Expense Occurrence</b> <input type="checkbox"/> One-time <input checked="" type="checkbox"/> Recurring <input type="checkbox"/> N/A	
Other budget impacts: (revenue generating, match requirements, etc.)	

**Operations Impacts** (If N/A, please give a brief description as to why)

- What impacts would the proposal have on historically excluded communities?  
Public works services and projects are designed to serve all citizens and businesses. We strive to offer a consistent level of service to all, to distribute public investment throughout the community and to respond to gaps in services identified in various City plans.
- How will data be collected, analyzed, and reported concerning the effect of the program/policy by racial, ethnic, gender identity, national origin, income level, disability, sexual orientation, or other existing disparities?  
N/A
- How will data be collected regarding the effectiveness of this program, policy, or product to ensure it is the right solution?  
Public Works follows the City's established procurement and public works bidding regulations and policies to bring items forward, and then uses contract management best practices to ensure desired outcomes and regulatory compliance.
- Describe how this proposal aligns with current City Policies, including the Comprehensive Plan, Sustainability Action Plan, Capital Improvement Program, Neighborhood Master Plans, Council Resolutions, and others?  
This work is consistent with annual budget strategies to limit costs and approved projects in the 6-year CIP.

**Council Subcommittee Review**

- Please provide a summary of council subcommittee review. If not reviewed by a council subcommittee, please explain why not.

# Contract Summary

## Laboratory Equipment and Supplies



[See vendors on this contract and their certifications](#)

Contract #: 20722

Replaces: [07215](#)

Contract Type: COOPERATIVE

### Contract Scope

The Department of Enterprise Services (DES), through partnership with NASPO ValuePoint, offers this contract as solicited by the state of Idaho for the purchase of laboratory equipment and supplies. State agencies, higher education, and political subdivisions are eligible to utilize this contract.

### Products Included

- Fisher Scientific Company - Full-line Catalog of Laboratory Equipment and Supplies
- Nikon Instruments Inc. - Microscopes and Accessories
- Thomas Scientific - Full-line Catalog of Laboratory Equipment and Supplies
- VWR International, LLC - Full-line Catalog of Laboratory Equipment and Supplies, Microscopes and Accessories

### How to Use this Contract

1. Select the 'Product Pricing' link below for the contractor of your choice to find downloadable product and pricing documents (right lower corner, under 'Documents/Details').
2. Contact the applicable sales representative directly to consult about their products and/or to place an order.
3. Reference State Contract No. 20722 on your purchase order.
4. Contact the Contract Administrator(s) listed below with any further questions.

### Awarded Contractors

#### Fisher Scientific Company, LLC

*Brian Gill*

[brian.gill@thermofisher.com](mailto:brian.gill@thermofisher.com)

(412) 657-1383

[Product Pricing](#)

#### Nikon Instruments Inc.

*Jacquelyn Perry*

[niiorderscontacts@nikon.net](mailto:niiorderscontacts@nikon.net)

(631) 547-8526

[Product Pricing](#)

#### Thomas Scientific

*Lewis McMillan*

[lewis.mcmillan@thomasci.com](mailto:lewis.mcmillan@thomasci.com)

(484) 280-8133

[Product Pricing](#)

#### VWR International, LLC

*Rebecca Richey*

[rebecca.richey@avantorsciences.com](mailto:rebecca.richey@avantorsciences.com)

(949) 510-4566

[Product Pricing](#)

DES has ensured this procurement meets [RCW 39.26](#), follows State of Washington [Current Procurement Policies](#), [follows DES procurement process](#), and DES has determined that entering into this contract will be in the best interest of the State of Washington.

**Found a Broken Link? [E-mail DES](#) so we can fix it ASAP.**

Effective Date: 03-01-2024

Est. Annual Worth: \$6,000,000

Current Term Ends On: 02-28-2029

Final Term Ends On:

Commodity Code(s): 260-02, 220-02, 680-02, 928-04, 495-05, 220-04, 271-08, 495-07, 493-04, 493-05, 470-06, 710-09, 928-10, 260-04, 470-10, 740-05, 495-08, 465-01, 690-14, 470-13, 465-02, 875-05, 271-10, 260-01, 465-03, 875-09, 495-09, 495-10

Diversity: 0% WBE 0% MBE

# of Bids Received:

Contact Info: Samantha Johnson ☎ (360) 790-9507

✉ [samantha.johnson@des.wa.gov](mailto:samantha.johnson@des.wa.gov)

Secondary Contact Nick Ioanna ☎ (360) 790-4257

Info:  
✉ [nicholas.ioanna@des.wa.gov](mailto:nicholas.ioanna@des.wa.gov)

Who Can Use This Contract?

- [Organizations with Statewide Contract Usage Agreements](#)
- [Customer Communication Profile](#)

>>>> [Vendor and Contract Performance Feedback Form](#)

>>>> Please send an email request to the Contract Manager for copies of any submitted feedback

- Amendment 1 - Fisher Scientific
- NASPO Contract - Fisher Scientific
- NASPO Contract - Nikon
- NASPO Contract - Thomas Scientific
- NASPO Contract - VWR
- Participating Addendum - Fisher Scientific
- Participating Addendum - Nikon
- Participating Addendum - Thomas Scientific
- Participating Addendum - VWR
  
- Original Solicitation
- Bid Tabulation

*This Contract has no Resource Documents*

### Showing 1 to 4 of 4 Vendors

All ▾ Vendors Per Page.









Search Vendors:



Vendor <span>↑↓</span>	Vendor # <span>↑↓</span>	OMWBE <span>↑↓</span>	Small Business <span>↑↓</span>	Veteran <span>↑↓</span>	Considerations / Preferences <span>↑↓</span>	Award Type <span>↑↓</span>
FISHER SCIENTIFIC, LLC	W2405					Main
NIKON INSTRUMENTS INC	W14809					Main
THOMAS SCIENTIFIC, LLC	W68935					Main
VWR INTERNATIONAL, LLC	W1692					Main



M = OMWBE Certified Minority Owned | W = OMWBE Certified Women Owned | MW = OMWBE Certified Minority Women Owned

[Award Types = Main, Reserved, and Main/Reserved](#)

-  = Veteran Owned
-  = Small Business
-  = [Preference Contract w/ Green Recycled Content](#)
-  = [\\*Preference Executive Order 18-03](#)
-  = [\\*Preference Electronic Products Purchasing](#)
-  = [\\*Preference Hydrofluorocarbons Products Purchasing](#)
-  = [\\*Preference Nonmercury-Added Products Purchasing](#)
-  = [\\*Preference Polychlorinated Biphenyls \(PCBs\) Purchasing](#)
- \* = Newly Added Icon.
-  = [All Other Green Considerations](#)

### Didn't find what you were looking for?

The Contracts Resource Center is here to help.

-  (360) 407-2210
-  [contractingandpurchasing@des.wa.gov](mailto:contractingandpurchasing@des.wa.gov)
-  [Find a Contracts Specialist](#)

**Agenda Sheet for City Council:****Committee:** PIES **Date:** 05/20/2024**Committee Agenda type:** Consent**Date Rec'd**

5/20/2024

**Clerk's File #**

OPR 2024-0447

**Cross Ref #**

OPR 2024-0445

**Cross Ref #**

OPR 2024-0446

**Council Meeting Date:** 06/10/2024**Submitting Dept**

WASTEWATER MANAGEMENT

**Bid #****Contact Name/Phone**

KYLE 625-4647

**Requisition #**

VALUE BLANKET

**Contact E-Mail**

KARRINGTON@SPOKANECITY.ORG

**Agenda Item Type**

Purchase w/o Contract

**Council Sponsor(s)**

BWILKERSON JBINGLE KKLITZKE

**Agenda Item Name**

4320 LAB SUPPLIES VALUE BLANKETS - MULTIPLE VENDORS

**Agenda Wording**

Value Blankets with multiple vendors for like Lab Supplies for the period of 06/01/2024 to 02/28/2029, total cost annually for all vendors is \$140,000.00 including tax.

OPR 2024-0447 - VWR International LLC

**Summary (Background)**

We are awarding to multiple vendors for like items. Together these vendors' equipment and supplies exceed the agenda threshold. This has been competed with DES and they are all accessing the same state contract. Contract number 20722 (Laboratory Equipment and Supplies) We are awarding value blankets to the following due to their state contracts. A. Fisher Scientific Company, LLC \$100,000.00 B. Thomas Scientific \$20,000.00 C. VWR International, LLC \$20,000.00 The time period is 06/01/2024 to 02/28/2029

Lease? NO

Grant related? NO

Public Works? NO

**Fiscal Impact**

Approved in Current Year Budget? YES

Total Cost \$ 140,000.00

Current Year Cost \$ 140,000.00

Subsequent Year(s) Cost \$ 140,000.00

**Narrative**

Value blankets set up to purchase required lab supplies.

**Amount****Budget Account**

Expense \$ 140,000.00

# 4320.43260.35148.53201

Select \$

#

Select \$

#

Select \$

#

\$

#

\$

#



## Continuation of Wording, Summary, Approvals, and Distribution

### Agenda Wording

### Summary (Background)

#### **Approvals**

##### Dept Head

GENNETT, RAYLENE

##### Division Director

FEIST, MARLENE

##### Accounting Manager

ALBIN-MOORE, ANGELA

##### Legal

HARRINGTON,

##### For the Mayor

JONES, GARRETT

#### **Additional Approvals**

#### **Distribution List**

	hbarnhart@spokanecity.org
kkeck@spokanecity.org	mmurray@spokanecity.org
Tax & Licenses	rpwrfaccounting@spokanecity.org
tlester@spokancity.org	

## Committee Agenda Sheet

### Public Infrastructure, Environment & Sustainability Committee

<b>Committee Date</b>	May 20 <sup>th</sup> , 2024
<b>Submitting Department</b>	Wastewater Management/RPWRP
<b>Contact Name</b>	Kyle Arrington
<b>Contact Email &amp; Phone</b>	<a href="mailto:karrington@spokanecity.org">karrington@spokanecity.org</a>
<b>Council Sponsor(s)</b>	CP Wilkerson, CM Bingle, CM Klitzke
<b>Select Agenda Item Type</b>	<input checked="" type="checkbox"/> Consent <input type="checkbox"/> Discussion    Time Requested:
<b>Agenda Item Name</b>	Lab Supplies – Value Blankets – multiple Vendors
<b>Proposed Council Action</b>	<input checked="" type="checkbox"/> Approval to proceed to Legislative Agenda <input type="checkbox"/> Information Only
<b>Summary (Background)</b>  *use the Fiscal Impact box below for relevant financial information	<p>We are awarding to multiple vendors for like items. Together these vendors' equipment and supplies exceed the agenda threshold. This has been competed with DES and they are all accessing the same state contract. Contract number 20722 (Laboratory Equipment and Supplies) We are awarding value blankets to the following due to their state contracts.</p> <ul style="list-style-type: none"> <li>A. Fisher Scientific Company, LLC \$100,000.00</li> <li>B. Thomas Scientific \$20,000.00</li> <li>C. VWR International, LLC \$20,000.00</li> </ul> <p>The time period is 06/01/2024 to 02/28/2029</p>
<b>Fiscal Impact</b>	
<b>Approved in current year budget?</b> <input checked="" type="checkbox"/> Yes <input type="checkbox"/> No <input type="checkbox"/> N/A Total Cost: <u>\$140,000.00</u> Current year cost: \$140,000.00 Subsequent year(s) cost: \$140,000.00	
<b>Narrative:</b> <u>A.</u> \$100,000.00 per year – Fisher <u>B.</u> \$20,000.00 per year – Thomas Scientific <u>C.</u> \$20,000.00 per year – VWR	
<b>Funding Source</b> <input type="checkbox"/> One-time <input checked="" type="checkbox"/> Recurring <input type="checkbox"/> N/A Specify funding source: Program revenue Is this funding source sustainable for future years, months, etc? Yes, Operating Budget	
<b>Expense Occurrence</b> <input type="checkbox"/> One-time <input checked="" type="checkbox"/> Recurring <input type="checkbox"/> N/A	
Other budget impacts: (revenue generating, match requirements, etc.)	

**Operations Impacts** (If N/A, please give a brief description as to why)

- What impacts would the proposal have on historically excluded communities?  
Public works services and projects are designed to serve all citizens and businesses. We strive to offer a consistent level of service to all, to distribute public investment throughout the community and to respond to gaps in services identified in various City plans.
- How will data be collected, analyzed, and reported concerning the effect of the program/policy by racial, ethnic, gender identity, national origin, income level, disability, sexual orientation, or other existing disparities?  
N/A
- How will data be collected regarding the effectiveness of this program, policy, or product to ensure it is the right solution?  
Public Works follows the City's established procurement and public works bidding regulations and policies to bring items forward, and then uses contract management best practices to ensure desired outcomes and regulatory compliance.
- Describe how this proposal aligns with current City Policies, including the Comprehensive Plan, Sustainability Action Plan, Capital Improvement Program, Neighborhood Master Plans, Council Resolutions, and others?  
This work is consistent with annual budget strategies to limit costs and approved projects in the 6-year CIP.

**Council Subcommittee Review**

- Please provide a summary of council subcommittee review. If not reviewed by a council subcommittee, please explain why not.

# Contract Summary

## Laboratory Equipment and Supplies



[See vendors on this contract and their certifications](#)

Contract #: 20722

Replaces: [07215](#)

Contract Type: COOPERATIVE

### Contract Scope

The Department of Enterprise Services (DES), through partnership with NASPO ValuePoint, offers this contract as solicited by the state of Idaho for the purchase of laboratory equipment and supplies. State agencies, higher education, and political subdivisions are eligible to utilize this contract.

### Products Included

- Fisher Scientific Company - Full-line Catalog of Laboratory Equipment and Supplies
- Nikon Instruments Inc. - Microscopes and Accessories
- Thomas Scientific - Full-line Catalog of Laboratory Equipment and Supplies
- VWR International, LLC - Full-line Catalog of Laboratory Equipment and Supplies, Microscopes and Accessories

### How to Use this Contract

1. Select the 'Product Pricing' link below for the contractor of your choice to find downloadable product and pricing documents (right lower corner, under 'Documents/Details').
2. Contact the applicable sales representative directly to consult about their products and/or to place an order.
3. Reference State Contract No. 20722 on your purchase order.
4. Contact the Contract Administrator(s) listed below with any further questions.

### Awarded Contractors

#### Fisher Scientific Company, LLC

*Brian Gill*

[brian.gill@thermofisher.com](mailto:brian.gill@thermofisher.com)

(412) 657-1383

[Product Pricing](#)

#### Nikon Instruments Inc.

*Jacquelyn Perry*

[niiorderscontacts@nikon.net](mailto:niiorderscontacts@nikon.net)

(631) 547-8526

[Product Pricing](#)

#### Thomas Scientific

*Lewis McMillan*

[lewis.mcmillan@thomasci.com](mailto:lewis.mcmillan@thomasci.com)

(484) 280-8133

[Product Pricing](#)

#### VWR International, LLC

*Rebecca Richey*

[rebecca.richey@avantorsciences.com](mailto:rebecca.richey@avantorsciences.com)

(949) 510-4566

[Product Pricing](#)

DES has ensured this procurement meets [RCW 39.26](#), follows State of Washington [Current Procurement Policies](#), [follows DES procurement process](#), and DES has determined that entering into this contract will be in the best interest of the State of Washington.

**Found a Broken Link? [E-mail DES](#) so we can fix it ASAP.**

Effective Date: 03-01-2024

Est. Annual Worth: \$6,000,000

Current Term Ends On: 02-28-2029

Final Term Ends On:

Commodity Code(s): 260-02, 220-02, 680-02, 928-04, 495-05, 220-04, 271-08, 495-07, 493-04, 493-05, 470-06, 710-09, 928-10, 260-04, 470-10, 740-05, 495-08, 465-01, 690-14, 470-13, 465-02, 875-05, 271-10, 260-01, 465-03, 875-09, 495-09, 495-10

Diversity: 0% WBE 0% MBE

# of Bids Received:

Contact Info: Samantha Johnson ☎ (360) 790-9507

✉ [samantha.johnson@des.wa.gov](mailto:samantha.johnson@des.wa.gov)

Secondary Contact Nick Ioanna ☎ (360) 790-4257

Info:  
✉ [nicholas.ioanna@des.wa.gov](mailto:nicholas.ioanna@des.wa.gov)

Who Can Use This Contract?

- [Organizations with Statewide Contract Usage Agreements](#)
- [Customer Communication Profile](#)

>>>> [Vendor and Contract Performance Feedback Form](#)

>>>> Please send an email request to the Contract Manager for copies of any submitted feedback

- Amendment 1 - Fisher Scientific
- NASPO Contract - Fisher Scientific
- NASPO Contract - Nikon
- NASPO Contract - Thomas Scientific
- NASPO Contract - VWR
- Participating Addendum - Fisher Scientific
- Participating Addendum - Nikon
- Participating Addendum - Thomas Scientific
- Participating Addendum - VWR
  
- Original Solicitation
- Bid Tabulation

*This Contract has no Resource Documents*

### Showing 1 to 4 of 4 Vendors









All ▾ Vendors Per Page.

Search Vendors:

Vendor <span>↑↓</span>	Vendor # <span>↑↓</span>	OMWBE <span>↑↓</span>	Small Business <span>↑↓</span>	Veteran <span>↑↓</span>	Considerations / Preferences <span>↑↓</span>	Award Type <span>↑↓</span>
FISHER SCIENTIFIC, LLC	W2405					Main
NIKON INSTRUMENTS INC	W14809					Main
THOMAS SCIENTIFIC, LLC	W68935					Main
VWR INTERNATIONAL, LLC	W1692					Main



M = OMWBE Certified Minority Owned | W = OMWBE Certified Women Owned | MW = OMWBE Certified Minority Women Owned

[Award Types = Main, Reserved, and Main/Reserved](#)

-  = Veteran Owned
-  = Small Business
-  = [Preference Contract w/ Green Recycled Content](#)
-  = [\\*Preference Executive Order 18-03](#)
-  = [\\*Preference Electronic Products Purchasing](#)
-  = [\\*Preference Hydrofluorocarbons Products Purchasing](#)
-  = [\\*Preference Nonmercury-Added Products Purchasing](#)
-  = [\\*Preference Polychlorinated Biphenyls \(PCBs\) Purchasing](#)
- \* = Newly Added Icon.
-  = [All Other Green Considerations](#)

### Didn't find what you were looking for?

The Contracts Resource Center is here to help.

-  (360) 407-2210
-  [contractingandpurchasing@des.wa.gov](mailto:contractingandpurchasing@des.wa.gov)
-  [Find a Contracts Specialist](#)



**Agenda Sheet for City Council:****Committee:** PIES **Date:** 05/20/2024**Committee Agenda type:** Consent**Date Rec'd**

5/20/2024

**Clerk's File #**

OPR 2024-0448

**Cross Ref #****Project #****Council Meeting Date:** 06/10/2024**Submitting Dept**

WATER &amp; HYDROELECTRIC SERVICES

**Bid #**

#092222-CMM

**Contact Name/Phone**

SETH 509-742-8152

**Requisition #**

RE 20503

**Contact E-Mail**

SMCINTOSH@SPOKANECITY.ORG

**Agenda Item Type**

Purchase w/o Contract

**Council Sponsor(s)**

BWILKERSON JBINGLE KKLITZKE

**Agenda Item Name**

4100 UPRIVER HYDROELECTRIC BACKUP POWER GENERATOR

**Agenda Wording**

Purchase stationary generator to update Upriver Hydroelectric backup power generator.

**Summary (Background)**

This will replace the pre-emissions unit that is currently located in the occupied building, exposing City staff to diesel smoke, fumes and excessive noise whenever it runs. Western States Power Systems proposal is under SourceWell Contract # 092222-CAT.

Lease? NO

Grant related? NO

Public Works? NO

**Fiscal Impact**

Approved in Current Year Budget? YES

Total Cost \$ 107,149.18

Current Year Cost \$ 107,149.18

Subsequent Year(s) Cost \$ 0

**Narrative**

This purchase from Western States Power Systems is under Sourcewell contract # 092222-CAT.

**Amount****Budget Account**

Expense \$ 107,149.18

# 4100 42490 94340 56501 11024

Select \$

#

Select \$

#

Select \$

#

\$

#

\$

#



**Continuation of Wording, Summary, Approvals, and Distribution**

**Agenda Wording**

**Summary (Background)**

**Approvals**

<b><u>Dept Head</u></b>	SEARL, LOREN
<b><u>Division Director</u></b>	MCINTOSH, SETH
<b><u>Accounting Manager</u></b>	ALBIN-MOORE, ANGELA
<b><u>Legal</u></b>	HARRINGTON,
<b><u>For the Mayor</u></b>	PICCOLO, MIKE

**Additional Approvals**

<b><u>PURCHASING</u></b>	PRINCE, THEA

**Distribution List**

Brant Briody Brant.briody@wseco.com	rrpenaluna@spokanecity.org
nrussell@spokanecity.org	smcintosh@spokanecity.org
tlester@spokanecity.org	

## Committee Agenda Sheet

### Public Infrastructure, Environment & Sustainability Committee

<b>Committee Date</b>	
<b>Submitting Department</b>	Water Department
<b>Contact Name</b>	Seth McIntosh
<b>Contact Email &amp; Phone</b>	509-742-8154
<b>Council Sponsor(s)</b>	Wilkerson, Bingle, Klitzke
<b>Select Agenda Item Type</b>	<input type="checkbox"/> Consent <input type="checkbox"/> Discussion    Time Requested:
<b>Agenda Item Name</b>	<b>Upriver Hydroelectric Backup Power Generator</b>
<b>Proposed Council Action</b>	<input type="checkbox"/> Approval to proceed to Legislative Agenda <input type="checkbox"/> Information Only
<b>Summary (Background)</b>  *use the Fiscal Impact box below for relevant financial information	<b>The purchase of this stationary generator is to update Upriver Hydroelectric Project’s backup power generator to a modern, fuel efficient unit located outdoors. This will replace the pre-emissions unit that is currently located in the occupied building, exposing City staff to diesel smoke, fumes and excessive noise whenever it runs. Western States Power Systems proposal is under SourceWell Contract # 092222-CAT.</b>
<b>Fiscal Impact</b> <b>Approved in current year budget?</b> <input checked="" type="checkbox"/> Yes <input type="checkbox"/> No <input type="checkbox"/> N/A Total Cost: <u>\$107,149.18</u> Current year cost: \$107,149.18 Subsequent year(s) cost: N/A  <b>Narrative:</b> <u>This purchase from Western States Power Systems is under Sourcewell contract # 092222-CAT. The budget line is 4100 42490 94340 56501 11024</u>  <b>Funding Source</b> <input checked="" type="checkbox"/> One-time <input type="checkbox"/> Recurring <input type="checkbox"/> N/A Specify funding source: Select Funding Source* Is this funding source sustainable for future years, months, etc? N/A  <b>Expense Occurrence</b> <input checked="" type="checkbox"/> One-time <input type="checkbox"/> Recurring <input type="checkbox"/> N/A  Other budget impacts: (revenue generating, match requirements, etc.)	
<b>Operations Impacts (If N/A, please give a brief description as to why)</b> <ul style="list-style-type: none"> <li>• What impacts would the proposal have on historically excluded communities?              Public works services and projects are designed to serve all citizens and businesses. We strive to offer a consistent level of service to all, to distribute public investment throughout the community and to respond to gaps in services identified in various City plans. We recognize the need to maintain affordability and predictability for utility customers and we are committed to delivering work that is both financially and environmentally responsible. This project is specifically designed to assist low-income residents get caught up on their City utility bills.</li> </ul>	

- How will data be collected, analyzed, and reported concerning the effect of the program/policy by racial, ethnic, gender identity, national origin, income level, disability, sexual orientation, or other existing disparities?

N/A

- How will data be collected regarding the effectiveness of this program, policy, or product to ensure it is the right solution?

Public Works follows the City's established procurement and public works bidding regulations and policies to bring items forward, and then uses contract management best practices to ensure desired outcomes and regulatory compliance.

- Describe how this proposal aligns with current City Policies, including the Comprehensive Plan, Sustainability Action Plan, Capital Improvement Program, Neighborhood Master Plans, Council Resolutions, and others?

This work is consistent with annual budget strategies to limit costs and approved projects in the 6-year CIP.

### **Council Subcommittee Review**

- Please provide a summary of council subcommittee review. If not reviewed by a council subcommittee, please explain why not.



# Proposal

**Project: City of Spokane Water Dept 400kW Genset**

**Date: 12/27/2023**

**Quote: 31295321**

**Attn: Cary Rickman**

**Valid: 30 days**

**From: Brant Briody**

Hello Cary,

We are pleased to offer the below quotation for a Caterpillar diesel fueled 400kW generator set.

The proposed 400kW unit will be equipped as follows:

- Diesel fueled, 277/480V, standby
- US EPA emissions certified for standby use
- UL2200 listed and labeled
- UL142 double wall base tank, 24 hours at 100% load
  - 5 gallon fill spill containment box, lockable
- Exterior weather protective and sound attenuating enclosure (71 dBA @ 23' full load)
  - Cat white powder coat finish
- 100% rated LS/I 600A main circuit breaker
- Ground fault indication relay per code
- Heavy duty PMG (permanent magnet) generator excitation
- Anti-condensation winding heater
- Jacket water coolant heater
- 24VDC lead acid starting battery set with 10 amp charger
- 1ea remote E-stop button
- Common alarm and generator running relay outputs
- CAT PL444 modem providing remote cellular monitoring capability
- 5 year warranty
- 1 year complimentary preventative maintenance program
- Freight direct from factory to jobsite
- On-site start up, testing, owner training

**Total Price as quoted above: \$98,302**

**Included:**

Startup: PS-Specialist  
Maintenance Program: 1 year complimentary  
Spare parts kit: No  
Warranty Genset: 60 month gold  
Warranty ATS: N/A

Freight: Included to first destination  
Site Load test: 100% available building load  
Factory Test: 100% load  
Owner training: Yes

**Not included:**

Installation  
Taxes / Permits of any kind / Any engineering  
Coordination Studies  
Any fuel or fuel piping

Offloading at jobsite  
Anchors and anchor calculations  
Third party testing  
Automatic Transfer Switch

**Notes and clarifications:**

1. No official engineered bid specifications or drawings were used as a basis for this proposal.
2. Lead times: 18 weeks out of the factory, including delivery. Please note that we have (1) new 400kW in stock in Liberty Lake at the moment, offered subject to prior sale.
3. This pricing is per Caterpillar’s Sourcewell contract # 092222-CAT offered specifically for City of Spokane (Sourcewell account # 33592). This pre-satisfies any need you may have to go out to bid.

**Terms:**

100% of payment is required prior to startup and testing on the jobsite.  
Payment terms are in accordance with WSECO Standard terms upon approved account.  
No retainer is allowed unless specifically agreed to in writing prior to order placement.  
Cancellation charges minimum of 25% once released. No return on manual transfer switches.  
No Liquidated Damages of any type, unless specifically agreed to in writing prior to order.  
For complete terms and conditions please visit: <https://www.westernstatescat.com/wp-content/uploads/2022/07/Sales-Agreement-Terms-and-Conditions-Equipment.pdf>

Thank you for the opportunity to quote quality Caterpillar products and services. Please let me know how we can be of assistance.

Sincerely,

Accepted By:

Brant Briody  
Power System Sales  
Spokane: 509-535-1744  
Pasco: 509-547-9541  
Lewiston: 208-746-3301

\_\_\_\_\_  
Signature:

\_\_\_\_\_  
Company:

# Cat® D400 GC

## Diesel Generator Sets



Standby : 60 Hz



Image shown may not reflect actual configuration.

Engine Model	Cat® C13 In-line 6, 4-cycle diesel
Bore x Stroke	130 mm x 157 mm (5.1 in x 6.2 in)
Displacement	12.5 L (763 in³)
Compression Ratio	16.3:1
Aspiration	Turbocharged Air-to-Air Aftercooled
Fuel Injection System	MEUI
Governor	Electronic ADEM™ A4

Model	Standby	Emission Strategy
D400 GC	400 ekW, 500 kVA	EPA Certified for Stationary Emergency Application

### PACKAGE PERFORMANCE

Performance	Standby
Frequency	60 Hz
Genset Power Rating	500 kVA
Genset power rating with fan @ 0.8 power factor	400 ekW
Emissions	EPA TIER 3
Performance Number	EM1694
Fuel Consumption	
100% load with fan, L/hr (gal/hr)	105.8 (27.9)
75% load with fan, L/hr (gal/hr)	90.7 (24.0)
50% load with fan, L/hr (gal/hr)	66.2 (17.5)
25% load with fan, L/hr (gal/hr)	37.7 (10.0)
Cooling System <sup>1</sup>	
Radiator air flow restriction (system), kPa (in water)	0.12 (0.48)
Radiator air flow, m³/min (cfm)	398 (14055)
Engine coolant capacity, L (gal)	66.2 (17.5)
Radiator coolant capacity, L (gal)	37.7 (10)
Total coolant capacity, L (gal)	104 (27.5)
Inlet Air	
Combustion air inlet flow rate m³/min (cfm)	24.4 (862)
Max. Allowable Combustion Air Inlet Temp, °C (°F)	47 (116)
Exhaust System	
Exhaust stack gas temperature, °C (°F)	567 (1053)
Exhaust gas flow rate, m³/min (cfm)	82 (2896)
Exhaust system backpressure (maximum allowable) kPa (in. water)	10 (40)
Heat Rejection	
Heat rejection to jacket water, kW (BTU/min)	156 (8871)
Heat rejection to exhaust (total), kW (BTU/min)	398 (22634)
Heat rejection to aftercooler, kW (BTU/min)	71 (4037)
Heat rejection to atmosphere from engine, kW (BTU/min)	52 (2957)
Heat rejection from alternator, kW (BTU/min)	29 (1649)
Emissions (Nominal) <sup>2</sup>	
NOx, mg/Nm³ (g/hp-hr)	2274.7 (4.58)
CO, mg/Nm³ (g/hp-hr)	666.9 (1.35)
HC, mg/Nm³ (g/hp-hr)	6.2 (0.01)
PM, mg/Nm³ (g/hp-hr)	39.4 (0.10)

# D400 GC Diesel Generator Sets

## Electric Power



Alternator <sup>3</sup>		
Voltages	480V	600V
Motor starting capability @ 30% Voltage Dip, skVA	871	731
Current Amps	601.4	481.1
Frame Size	M3134L4	M3115L4
Excitation	S.E	AREP
Temperature Rise, °C	105	130

### WEIGHTS & DIMENSIONS – OPEN SET

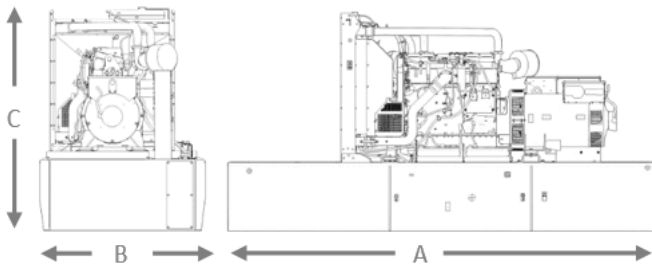

### FUEL TANK CAPACITY

Tank Design	Total Capacity L (gal)	Useable Capacity L (gal)
Integral	2820 (744.9)	2553 (674.4)

Base	Length "A" mm (in)	Width "B" mm (in)	Height "C" mm (in)	Generator Set Weight kg (lb)
Skid (Wide Base)	4625 (182.8)	1630 (64.2)	2039 (80.3)	3325 (7330.4)
Integral Tank Base	4625 (182.8)	1630 (64.2)	2456 (96.7)	4107 (9054.4)

**Note:** General configuration not to be used for installation. See general dimension drawings for detail.

#### APPLICABLE CODES AND STANDARDS:

AS1359, CSA C22.2 No100-04, UL142, UL489, UL869, UL2200, NFPA37, NFPA70, NFPA99, NFPA110, IBC, IEC60034-1, ISO3046, ISO8528, NEMA MG1-22, NEMA MG1-33, 2006/95/EC, 2006/42/EC, 2004/108/EC.

Note: Codes may not be available in all model configurations. Please consult your local Cat Dealer representative for availability.

**STANDBY:** Output available with varying load for the duration of the interruption of the normal source power. Average power output is 70% of the standby power rating. Typical operation is 200 hours per year, with maximum expected usage of 500 hours per year.

**RATINGS:** Ratings are based on SAE J1349 standard conditions. These ratings also apply at ISO3046 standard conditions.

**FUEL RATES:** Based on fuel oil of 35° API [16° C (60° F)] gravity having an LHV of 42 780 kJ/kg (18,390 Btu/lb) when used at 29° C (85° F) and weighing 838.9 g/litre (7.001 lbs/U.S. gal.). Additional ratings may be available for specific customer requirements, contact your Caterpillar representative for details. For information regarding Low Sulfur fuel and Biodiesel capability, please consult your Cat dealer.

#### DEFINITIONS AND CONDITIONS

<sup>1</sup> For ambient and altitude capabilities consult your Cat dealer. Air flow restriction (system) is added to existing restriction from factory.

<sup>2</sup> Emissions data measurement procedures are consistent with those described in EPA CFR 40 Part 89, Subpart D & E and ISO8178-1 for measuring HC, CO, PM, NOx. Data shown is based on steady state operating conditions of 77° F, 28.42 in HG and number 2 diesel fuel with 35° API and LHV of 18,390 BTU/lb. The nominal emissions data shown is subject to instrumentation, measurement, facility and engine to engine variations. Emissions data is based on 100% load and thus cannot be used to compare to EPA regulations which use values based on a weighted cycle.

<sup>3</sup> UL 2200 Listed packages may have oversized generators with a different temperature rise and motor starting characteristics. Generator temperature rise is based on a 40° C ambient per NEMA MG1-32.

# LET'S DO THE WORK.™

LEHE2009-08 (10/23)

[www.cat.com/electricpower](http://www.cat.com/electricpower)

©2023 Caterpillar  
All rights reserved.

Materials and specifications are subject to change without notice.

The International System of Units (SI) is used in this publication. CAT, CATERPILLAR, LET'S DO THE WORK, their respective logos, "Caterpillar Corporate Yellow", the "Power Edge" and Cat "Modern Hex" trade dress as well as corporate and product identity used herein, are trademarks of Caterpillar and may not be used without permission.





Image shown may not reflect actual configuration.

## D250 GC – D600 GC Sound Attenuated Enclosures

60 Hz

### Features

#### Robust/Highly Corrosion Resistant Construction

- Safeguards genset against environmental and weather conditions.
- Factory installed on skid base or tanks base.
- Environmentally friendly, polyester powder baked paint.
- Enclosure constructed with 18-gauge steel.
- Interior zinc plated fasteners.
- Internally mounted exhaust silencing system.
- Comply with ASCE /SEI 7 for Wind loads up to 100 mph.
- Designed and tested to comply with UL 2200 Listed generator set package.

#### Excellent Access

- Large cable entry area for installation ease.
- Accommodates side mounted single or multiple breakers.
- Two doors on both sides.
- Vertically hinged allow 180° opening rotation.
- Radiator fill cover.

#### Security and Safety

- Lockable access doors which give full access to control panel and breaker.
- Cooling fan and battery charging alternator fully guarded.
- Fuel fill, oil fill and battery can only be reached via lockable access.
- Externally mounted emergency stop button (Optional).
- Designed for spreader bar lifting to ensure safety.
- Stub-up area is rodent proof.

#### Sound Attenuated Level 2

- Caterpillar white paint.
- UL Listed integral fuel tank with 24 hours running time capacity (Optional).
- DC lighting package (Optional).

## Enclosure Package Operating Characteristics

Enclosure Type	Standby	Cooling Air Flow Rate		Ambient Capability*		Sound Pressure Levels (dBA) at 7m (23 ft)
	ekW	m <sup>3</sup> /s	cfm	°C	°F	100% Load
Level 2 Sound Attenuated Enclosure (Steel)	250	6.4	13561	57	135	74
	300	6.4	13561	51	125	74
	350	7.4	15680	57	134	71
	400	7.4	15680	53	127	71
	450	8.4	17692	54	130	73
	500	8.4	17692	50	122	73
	550	11.2	23731	56	133	73
	600	11.2	23731	53	127	73

\*Cooling system performance at sea level. Consult your Cat<sup>®</sup> dealer for site specific ambient and altitude capabilities.

**Note:** Sound level measurements are subject to instrumentation, installation and manufacturing variability, as well as ambient site conditions

## Weights and Dimensions

Enclosure Type	Standby Ratings	Length, L		Width, W		Height, H		Package Weights	
	ekW	mm	in	mm	in	mm	in	kg	lb
Sound Attenuated Enclosure on Skid Base	250	3958	155.8	1440	56.7	1991	78.4	2857	6298.6
	300							2945	6492.6
	350	4633	182.4	1630	64.2	2227	87.7	3983	8781.0
	400							4017	8856.0
	450	4823	189.8	1630	64.2	2227	87.7	4408	9718.0
	500							4457	9826.0
	550	4980	196.1	1865	73.4	2172	85.5	4754	10480.8
	600							4837	10663.8
Sound Attenuated Enclosure on UL listed Integral Fuel Tank Base	250	3958	155.8	1440	56.7	2487	97.9	3497	7709.6
	300							3585	7903.6
	350	4633	182.4	1630	64.2	2644	104.1	4765	10505.0
	400							4799	10580.0
	450	4823	189.8	1630	64.2	2777	109.3	5345	11783.7
	500							5394	11891.7
	550	4980	196.1	1865	73.4	2723	107.2	5973	13168.2
	600							6056	13351.2
Sound Attenuated Enclosure on UL listed Extended Integral Fuel Tank Base	250	4608	181.4	1430	56.3	2379	93.7	3590	7914.6
	300							3678	8108.6
	350	5251	203.7	1620	63.8	2561	100.8	4876	10749.7
	400							4910	10824.7
	450	5909	232.6	1620	63.8	2612	102.8	5497	12118.8
	500							5546	12226.8
	550	6759	266.1	1865	73.4	2487	97.9	6237	13750.2
	600							6320	13933.2

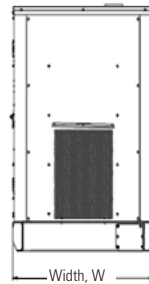
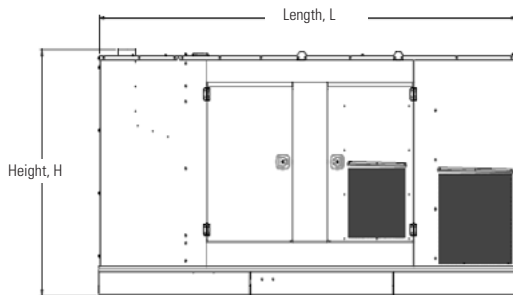

**Sound Attenuated Enclosure on Skid Base**

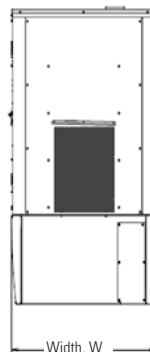
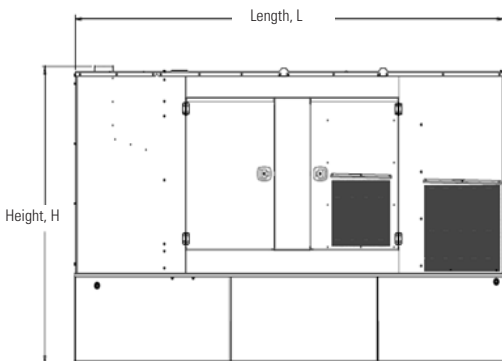

**Sound Attenuated Enclosure on a UL listed Integral Fuel Tank Base**

Image shown may not reflect actual configuration.

**LET'S DO THE WORK.™**

[www.cat.com/electricpower](http://www.cat.com/electricpower)

©2023 Caterpillar. All rights reserved.

Materials and specifications are subject to change without notice.

The International System of Units (SI) is used in this publication. CAT, CATERPILLAR, LET'S DO THE WORK, their respective logos, "Caterpillar Corporate Yellow", the "Power Edge" and Cat "Modern Hex" trade dress as well as corporate and product identity used herein, are trademarks of Caterpillar and may not be used without permission.



**Agenda Sheet for City Council:**

**Committee:** PIES **Date:** 05/20/2024

**Committee Agenda type:** Consent

**Date Rec'd**

5/20/2024

**Clerk's File #**

OPR 2024-0449

**Cross Ref #**

**Project #**

**Council Meeting Date:** 06/10/2024

**Submitting Dept**

STREETS

**Bid #**

ITB 6117-24

**Contact Name/Phone**

CLINT HARRIS 625-7744

**Requisition #**

**Contact E-Mail**

CEHARRIS@SPOKANECITY.ORG

**Agenda Item Type**

Purchase w/o Contract

**Council Sponsor(s)**

BWILKERSON JBINGLE KKLITZKE

**Agenda Item Name**

1100 - STREETS PREFORMED THERMOPLASTIC

**Agenda Wording**

Streets is seeking approval for the purchase of preformed thermoplastic at a cost not to exceed \$75,000.00 annually.

**Summary (Background)**

This contract, awarded via bid (ITB 6117-24) to Ennis-Flint, Inc. (Greensboro, NC) will be for five years beginning on July 15th, 2024. Thermoplastic is a material is used widely across the City's roadway system as a form of surface marking to facilitate safe movement along City roads

Lease? NO

Grant related? NO

Public Works? NO

**Fiscal Impact**

Approved in Current Year Budget? YES

Total Cost \$ 375,000.00

Current Year Cost \$ 75,000.00

Subsequent Year(s) Cost \$ 75,000.00/year for 2025-2029

**Narrative**

**Amount**

**Budget Account**

Expense \$ 75,000.00

# 1100-21400-42640-53210-99999

Select \$

#

Select \$

#

Select \$

#

\$

#

\$

#



**Continuation of Wording, Summary, Approvals, and Distribution**

**Agenda Wording**

**Summary (Background)**

**Approvals**

<b><u>Dept Head</u></b>	HARRIS, CLINT E.
<b><u>Division Director</u></b>	FEIST, MARLENE
<b><u>Accounting Manager</u></b>	ORLOB, KIMBERLY
<b><u>Legal</u></b>	HARRINGTON,
<b><u>For the Mayor</u></b>	JONES, GARRETT

**Additional Approvals**

<b><u>PURCHASING</u></b>	PRINCE, THEA

**Distribution List**

Crystal Gentry cgentry@ppg.com	ceharris@spokanecity.org
jwthomas@spokanecity.org	meveland@spokanecity.org
rlynch@spokanecity.org	jklapp@spokanecity.org
streetaccounting@spokanecity.org	rrinderle@spokanecity.org
tprince@spokanecity.org	

## Committee Agenda Sheet

### Public Infrastructure, Environment & Sustainability Committee

<b>Committee Date</b>	05/20/2024
<b>Submitting Department</b>	Streets
<b>Contact Name</b>	Clint Harris
<b>Contact Email &amp; Phone</b>	<a href="mailto:ceharris@spokanecity.org">ceharris@spokanecity.org</a> , 509-625-7744
<b>Council Sponsor(s)</b>	<u>Wilkerson, Bingle, Klitzke</u>
<b>Select Agenda Item Type</b>	<input checked="" type="checkbox"/> Consent <input type="checkbox"/> Discussion    Time Requested:
<b>Agenda Item Name</b>	1100 – Streets Preformed Thermoplastic
<b>Proposed Council Action</b>	<input checked="" type="checkbox"/> Approval to proceed to Legislative Agenda <input type="checkbox"/> Information Only
<b>Summary (Background)</b>	<p>Streets is seeking approval for the purchase of preformed thermoplastic at a cost not to exceed \$75,000.00 annually. This contract, awarded via bid (ITB 6117-24) to Ennis Flint will be for five years beginning on July 15<sup>th</sup>, 2024 (total cost of \$375,000.00 for the span of the contract).</p> <p>Thermoplastic is a material is used widely across the City’s roadway system as a form of surface marking to facilitate safe movement along City roads.</p>
<b>Fiscal Impact</b>	\$75,000.00
<b>Approved in current year budget?</b>	<input checked="" type="checkbox"/> Yes <input type="checkbox"/> No <input type="checkbox"/> N/A
Total Cost: <a href="#">Click or tap here to enter text.</a>	
Current year cost: \$75,000.00	
Subsequent year(s) cost: \$75,000 /year	
<b>Narrative:</b> Please provide financial due diligence review, as applicable, such as number and type of positions, grant match requirements, summary type details (personnel, maintenance and supplies, capital, revenue), impact on rates, fees, or future shared revenue	
<b>Funding Source</b>	<input type="checkbox"/> One-time <input checked="" type="checkbox"/> Recurring <input type="checkbox"/> N/A
Specify funding source: Program revenue	
Is this funding source sustainable for future years, months, etc? <a href="#">Click or tap here to enter text.</a>	
<b>Expense Occurrence</b>	<input type="checkbox"/> One-time <input checked="" type="checkbox"/> Recurring <input type="checkbox"/> N/A
Other budget impacts: (revenue generating, match requirements, etc.)	
<b>Operations Impacts</b> (If N/A, please give a brief description as to why)	
What impacts would the proposal have on historically excluded communities? N/A	
<u>Thermoplastic is used based upon existing road marking conditions and their maintenance needs</u>	
How will data be collected, analyzed, and reported concerning the effect of the program/policy by racial, ethnic, gender identity, national origin, income level, disability, sexual orientation, or other existing disparities? N/A	
<u>Thermoplastic is used based upon existing road marking conditions and their maintenance needs</u>	

How will data be collected regarding the effectiveness of this program, policy or product to ensure it is the right solution? N/A

Thermoplastic is used based upon existing road marking conditions and their maintenance needs

Describe how this proposal aligns with current City Policies, including the Comprehensive Plan, Sustainability Action Plan, Capital Improvement Program, Neighborhood Master Plans, Council Resolutions, and others? N/A

Thermoplastic is used based upon existing road marking conditions and their maintenance needs



CITY OF SPOKANE

Nelson Center

Purchasing

PHONE 509 625 6527

**ITB 6117-24 PERFORMED THERMOPLASTIC, As-Needed**

Annual Estimated quantities are for the purpose of comparing bids on a uniform basis. Payment will be made only for quantities actually ordered, delivered and accepted, whether greater or less than the stated amounts.

Pricing submitted on "Pricing Page" must be a firm throughout the first year of the Value Blanket Period. Pricing adjustments can be requested annually on the anniversary of award with justification.

Part numbers shown are Ennis-Flint, and are used for reference only.

"ALL" FREIGHT/SHIPPING IS THE RESPONSIBILITY OF THE WINNING VENDOR, as stated in bid.

VENDOR:			ENNIS-Flint, Inc.		Geveko Markings Inc		Rodda Paint	
Description	Unit	Annual Est. Qty	Unit Price	Extended	Unit Price	Extended	Unit Price	Extended
<b>ITEMS IN 125 MIL YELLOW</b>								
4" X 36" (90' LF PER PACK), #PM600101	PKG	15	\$70.11	\$1,051.65	\$91.38	\$1,370.70	\$109.40	\$1,641.00
<b>ITEMS IN 125 MIL WHITE</b>								
4" X 36" (90' LF PER PACK), #PM600100	PKG	1	\$65.45	\$65.45	\$93.07	\$93.07	\$103.40	\$103.40
6" X 36" (60' LF PER PACK), #8432061	PKG	1	\$65.45	\$65.45	\$93.07	\$93.07	\$96.20	\$96.20
8" X 24" (60' LF PER PACK), #8433062	PKG	50	\$87.26	\$4,363.00	\$113.73	\$5,686.50	\$96.20	\$4,810.00
8" X 36" (45' LF PER PACK), #PM600102	PKG	150	\$65.45	\$9,817.50	\$85.31	\$12,796.50	\$103.20	\$15,480.00
24" X 36" (15' LF PER PACK), #8430566	PKG	50	\$65.45	\$3,272.50	\$85.31	\$4,265.50	\$103.40	\$5,170.00
STRAIGHT ARROW, WA. STATE LOW SPEED TYPE 1S (2 PER PACK), #83302275	PKG	10	\$69.06	\$690.60	\$85.90	\$859.00	\$123.60	\$1,236.00
LEFT ARROW, WA. STATE LOW SPEED TYPE 2SL (2 PER PACK), #83302276L	PKG	10	\$66.57	\$665.70	\$82.82	\$828.20	\$110.00	\$1,100.00
RIGHT ARROW, WA. STATE LOW SPEED TYPE 2SR (2 PER PACK), #83302276R	PKG	10	\$66.57	\$665.70	\$82.82	\$828.20	\$110.00	\$1,100.00
COMBI LEFT ARROW, WA. STATE LOW SPEED TYPE 3SL (1 PER PACK), #83301277L	EA	10	\$63.53	\$635.30	\$91.18	\$911.80	\$129.20	\$1,292.00
COMBI RIGHT ARROW, WA. STATE LOW SPEED TYPE 3SR (1 PER PACK), #83301277R	EA	1	\$63.53	\$63.53	\$91.18	\$91.18	\$129.20	\$129.20
COMBI LEFT/ RIGHT ARROW, WA. STATE LOW SPEED TYPE 4S (1 PER PACK)	EA	1	\$54.88	\$54.88	\$78.82	\$78.82	\$128.60	\$128.60
LANE REDUCTION ARROW, LEFT, WA. STATE LOW SPEED TYPE 6SL, #83301274L	EA	1	\$68.18	\$68.18	\$97.97	\$97.97	\$277.20	\$277.20
LANE REDUCTION ARROW, RIGHT, WA. STATE LOW SPEED TYPE 6SR, #83301274R	EA	1	\$68.18	\$68.18	\$97.97	\$97.97	\$277.20	\$277.20
COMBI LEFT/ STRAIGHT/ RIGHT ARROW, WA. STATE LOW SPEED TYPE 7S (1 PER PACK)	EA	1	\$89.15	\$89.15	\$273.28	\$273.28	\$342.00	\$342.00
ROUNDBOUT ARROW, WA. STATE TYPE TC	EA	1	\$89.32	\$89.32	\$167.17	\$167.17	\$267.60	\$267.60
ROUNDBOUT ARROW, WA. STATE TYPE LTC	EA	1	\$116.48	\$116.48	\$227.96	\$227.96	\$356.40	\$356.40
ROUNDBOUT ARROW, WA. STATE TYPE TRC	EA	1	\$111.09	\$111.09	\$212.76	\$212.76	\$356.40	\$356.40
ROUNDBOUT ARROW, WA. STATE TYPE LTRC	EA	1	\$138.15	\$138.15	\$273.50	\$273.50	\$445.20	\$445.20
ROUNDBOUT ARROW, WA. STATE TYPE LC	EA	1	\$87.01	\$87.01	\$136.77	\$136.77	\$267.60	\$267.60
"ONLY", #8130102	EA	2	\$98.07	\$196.14	\$153.27	\$306.54	\$154.80	\$309.60



"BUS", #8130117	EA	2	\$80.85	\$161.70	\$126.36	\$252.72	\$127.20	\$254.40
"R X R" KIT, NARROW, FHWA	EA	4	\$187.74	\$750.96	\$248.78	\$995.12	\$296.40	\$1,185.60
<b>ITEMS IN 90 MIL WHITE</b>								
BICYCLE RIDER (5 PER PACK), #PM602006L	PKG	1	\$297.15	\$297.15	\$464.40	\$464.40	\$471.60	\$471.60
BIKE LANE STRAIGHT ARROW (5 PER PACK), #PM602005-5PK	PKG	1	\$127.09	\$127.09	\$79.42	\$79.42	\$201.60	\$201.60
SHARED LANE SYMBOL #PM600833L	EA	10	\$152.78	\$1,527.80	\$202.45	\$2,024.50	\$250.80	\$2,508.00
<b>ITEMS IN 125 MIL, BLACK</b>								
CONTRASTING RETROFIT KIT FOR WA. STATE LOW SPEED TYPE 1S (2 PER PACK)	PKG	10	\$43.93	\$439.30	\$21.36	\$213.60	\$188.40	\$1,884.00
CONTRASTING RETROFIT KIT FOR WA. STATE LOW SPEED TYPE 2SL (2 PER PACK)	PKG	10	\$42.35	\$423.50	\$24.67	\$246.70	\$172.80	\$1,728.00
CONTRASTING RETROFIT KIT FOR WA. STATE LOW SPEED TYPE 2SR (2 PER PACK)	PKG	10	\$42.35	\$423.50	\$24.67	\$246.70	\$172.80	\$1,728.00
CONTRASTING RETROFIT KIT FOR WA. STATE LOW SPEED TYPE 3SL (1 PER PACK)	EA	10	\$90.30	\$903.00	\$37.80	\$378.00	\$194.40	\$1,944.00
CONTRASTING RETROFIT KIT FOR WA. STATE LOW SPEED TYPE 3SR (1 PER PACK)	EA	10	\$90.30	\$903.00	\$37.80	\$378.00	\$194.40	\$1,944.00
CONTRASTING RETROFIT KIT FOR "ONLY"	EA	2	\$45.36	\$90.72	\$49.74	\$99.48	\$170.40	\$340.80
CONTRASTING RETROFIT KIT FOR "BUS"	EA	2	\$34.09	\$68.18	\$29.63	\$59.26	\$158.40	\$316.80
<b>ITEMS IN 90 MIL GREEN</b>								
6" X 36" (60' LF PER PACK)	PKG	2	\$77.91	\$155.82	\$121.76	\$243.52	\$109.20	\$218.40
24" X 36" (15' LF PER PACK)	PKG	2	\$77.91	\$155.82	\$121.76	\$243.52	\$109.20	\$218.40
<b>PCC Sealer</b>								
SEALER FOR APPLICATIONS ON CONCRETE	GAL	5	\$203.60	\$1,018.00	Did not complete revised pricing page so pricing for item was not bid		\$28.80	\$144.00
<b>Subtotal</b>			<b>\$29,820.50</b>		<b>\$35,621.40</b>		<b>\$50,273.20</b>	
<b>WA State Sales Tax (9%)</b>			<b>\$2,683.85</b>		<b>\$3,205.93</b>		<b>\$4,524.59</b>	
<b>Extended Total</b>			<b>\$32,504.35</b>		<b>\$38,827.33</b>		<b>\$54,797.79</b>	
<b>Bidder MUST complete and upload Technical Specification Sheet. Upload here, If not uploaded bid may be considered non-responsive.</b>			<b>Provided</b>		<b>Provided</b>		<b>Provided</b>	
<b>Catalog Submitted With Quote</b>			<b>Provided</b>		<b>Not Provided</b>		<b>Not Provided</b>	
<b>Any items not shown on the PRICING SHEET will be priced at ___% below list price in submitted catalog.</b>			<b>30% BELOW</b>		<b>39% BELOW</b>		<b>25% BELOW</b>	



**Agenda Sheet for City Council:**

**Committee:** PIES **Date:** 05/20/2024

**Committee Agenda type:** Consent

**Date Rec'd**

5/20/2024

**Clerk's File #**

OPR 2024-0450

**Cross Ref #**

**Project #**

**Council Meeting Date:** 06/10/2024

**Submitting Dept**

STREETS

**Bid #**

ITB 6085-24

**Contact Name/Phone**

CLINT HARRIS 625-7744

**Requisition #**

VB

**Contact E-Mail**

CEHARRIS@SPOKANECITY.ORG

**Agenda Item Type**

Purchase w/o Contract

**Council Sponsor(s)**

BWILKERSON JBINGLE KKLITZKE

**Agenda Item Name**

1100 - STREETS PERFORATED SQUARE STEEL TUBES

**Agenda Wording**

Streets is seeking approval for the purchase of perforated square steel tubing at a cost not to exceed \$100,000.

**Summary (Background)**

This contract, awarded via bid (ITB 6085-24) to Zumar Industries, Inc. (Tacoma, WA) will be for five years, beginning August 1st, 2024. This perforated square steel tubing is used for the mounting of City signs during new installations as well as for repairs and replacements of existing infrastructure.

Lease? NO

Grant related? NO

Public Works? NO

**Fiscal Impact**

Approved in Current Year Budget? YES

Total Cost \$ 500,000.00

Current Year Cost \$ 100,000.00

Subsequent Year(s) Cost \$ 100,000.00/year 2025-2029

**Narrative**

**Amount**

**Budget Account**

Expense \$ 100,000.00

# 1100-21400-42640-53210-99999

Select \$

#

Select \$

#

Select \$

#

\$

#

\$

#



**Continuation of Wording, Summary, Approvals, and Distribution**

**Agenda Wording**

**Summary (Background)**

**Approvals**

<b><u>Dept Head</u></b>	HARRIS, CLINT E.
<b><u>Division Director</u></b>	FEIST, MARLENE
<b><u>Accounting Manager</u></b>	ORLOB, KIMBERLY
<b><u>Legal</u></b>	HARRINGTON,
<b><u>For the Mayor</u></b>	PICCOLO, MIKE

**Additional Approvals**

<b><u>PURCHASING</u></b>	PRINCE, THEA

**Distribution List**

Derek Behnke, derek@zumar.com	ceharris@spokanecity.org
jwthomas@spokanecity.org	meveland@spokanecity.org
rlynch@spokanecity.org	jklapp@spokanecity.org
rrinderle@spokanecity.org	streetaccounting@spokanecity.org
tprince@spokanecity.org	

## Committee Agenda Sheet

### Public Infrastructure, Environment & Sustainability Committee

<b>Committee Date</b>	05/20/2024
<b>Submitting Department</b>	Streets
<b>Contact Name</b>	Clint Harris
<b>Contact Email &amp; Phone</b>	<a href="mailto:ceharris@spokanecity.org">ceharris@spokanecity.org</a> , 509-625-7744
<b>Council Sponsor(s)</b>	<u>Wilkerson, Bingle, Klitzke</u>
<b>Select Agenda Item Type</b>	<input checked="" type="checkbox"/> Consent <input type="checkbox"/> Discussion    Time Requested:
<b>Agenda Item Name</b>	1100 – Streets Perforated Square Steel tube
<b>Proposed Council Action</b>	<input checked="" type="checkbox"/> Approval to proceed to Legislative Agenda <input type="checkbox"/> Information Only
<b>Summary (Background)</b>	<p>Streets is seeking approval for the purchase of perforated square steel tubing at a cost not to exceed \$100,000 annually (total cost of \$500,000.00. This contract, awarded via bid (ITB 6085-24) to Zumar Industries will be for five years, beginning August 1<sup>st</sup>, 2024.</p> <p>This perforated square steel tubing is used for the mounting of City signs during new installations as well as for repairs and replacements of existing infrastructure.</p>
<b>Summary (Background)</b>	<p>*use the Fiscal Impact box below for relevant financial information</p>
<b>Fiscal Impact</b>	\$100,000.00
<b>Approved in current year budget?</b>	<input checked="" type="checkbox"/> Yes <input type="checkbox"/> No <input type="checkbox"/> N/A
<b>Total Cost:</b>	<u>\$100,000.00</u>
<b>Current year cost:</b>	\$100,000.00
<b>Subsequent year(s) cost:</b>	\$100,000/year for each renewal year
<b>Narrative:</b>	Please provide financial due diligence review, as applicable, such as number and type of positions, grant match requirements, summary type details (personnel, maintenance and supplies, capital, revenue), impact on rates, fees, or future shared revenue
<b>Funding Source</b>	<input type="checkbox"/> One-time <input checked="" type="checkbox"/> Recurring <input type="checkbox"/> N/A
<b>Specify funding source:</b>	Program revenue
<b>Is this funding source sustainable for future years, months, etc?</b>	Yes
<b>Expense Occurrence</b>	<input type="checkbox"/> One-time <input checked="" type="checkbox"/> Recurring <input type="checkbox"/> N/A
<b>Other budget impacts:</b>	(revenue generating, match requirements, etc.)
<b>Operations Impacts (If N/A, please give a brief description as to why)</b>	
<b>What impacts would the proposal have on historically excluded communities?</b>	N/A
<b>These steel tubes are used to replace and repair city signs in all areas of the City</b>	
<b>How will data be collected, analyzed, and reported concerning the effect of the program/policy by racial, ethnic, gender identity, national origin, income level, disability, sexual orientation, or other existing disparities?</b>	N/A
<b>These steel tubes are used to replace and repair city signs in all areas of the City</b>	

How will data be collected regarding the effectiveness of this program, policy or product to ensure it is the right solution? N/A

These steel tubes are used to replace and repair city signs in all areas of the City

Describe how this proposal aligns with current City Policies, including the Comprehensive Plan, Sustainability Action Plan, Capital Improvement Program, Neighborhood Master Plans, Council Resolutions, and others? N/A

These steel tubes are used to replace and repair city signs in all areas of the City



CITY OF SPOKANE  
 Nelson Center  
 Purchasing  
 PHONE 509 625 6527

**ITB 6085-24 Perforated Square Steel Tube (PSST) As-Needed**

Annual Estimated quantities are for the purpose of comparing bids on a uniform basis. Payment will be made only for quantities actually ordered, delivered and accepted, whether greater or less than the stated amounts.

VENDOR		National Barricade		Traffic Safety Supply Company		Elite Textile Trader		Zumar Industries, Inc.	
Item	Qty	Unit price	Extended Price	Unit price	Extended Price	Unit price	Extended Price	Unit price	Extended Price
2" X 9' PSST 12GA Meeting Stated Specifications: Unit Pricing Should Not Include Tax. Unit Pricing "Should" Include Freight. Unit Pricing shall be firm for 12 months from bid due date. Pricing adjustment will be considered on the anniversary of the award based on vendor providing back up documentation. Enter Unit Price Each:	200	\$55.00	\$11,000.00	\$33.80	\$6,760.00	\$20.10	\$4,020.00	\$39.00	\$7,800.00
2" X 10' PSST 12GA Meeting Stated Specifications: : Unit Pricing Should Not Include Tax. Unit Pricing "Should" Include Freight. Unit Pricing shall be firm for 12 months from bid due date. Pricing adjustment will be considered on the anniversary of the award based on vendor providing back up documentation. Enter Unit Price Each:	200	\$58.00	\$11,600.00	\$37.45	\$7,490.00	\$22.33	\$4,466.00	\$42.00	\$8,400.00
2" X11' PSST 12GA Meeting Stated Specifications: : Unit Pricing Should Not Include Tax. Unit Pricing "Should" Include Freight. Unit Pricing shall be firm for 12 months from bid due date. Pricing adjustment will be considered on the anniversary of the award based on vendor providing back up documentation. Enter Unit Price Each:	200	\$61.00	\$12,200.00	\$41.10	\$8,220.00	\$24.56	\$4,912.00	\$47.00	\$9,400.00
2" X 12' PSST 12GA Meeting Stated Specifications: : Unit Pricing Should Not Include Tax. Unit Pricing "Should" Include Freight. Unit Pricing shall be firm for 12 months from bid due date. Pricing adjustment will be considered on the anniversary of the award based on vendor providing back up documentation. Enter Unit Price Each:	200	\$62.00	\$12,400.00	\$45.30	\$9,060.00	\$26.79	\$5,358.00	\$50.00	\$10,000.00
1-3/4" X 12' PSST 14GA Meeting Stated Specifications: Unit Pricing Should Not Include Tax. Unit Pricing "Should" Include Freight. Unit Pricing shall be firm for 12 months from bid due date. Pricing adjustment will be considered on the anniversary of the award based on vendor providing back up documentation. Enter Unit Price Each:	200	\$50.00	\$10,000.00	\$34.05	\$6,810.00	\$19.11	\$3,822.00	\$39.00	\$7,800.00
<b>Subtotal</b>		\$57,200.00		\$38,340.00		\$22,578.00		\$43,400.00	
Tax 9%		\$5,148.00		\$3,450.60		\$2,032.02		\$3,906.00	
<b>Extended Total</b>		\$62,348.00		\$41,790.60		\$24,610.02		\$47,306.00	
Bidder MUST complete and upload Technical Specifications Sheet from "Documents" Tab or bidder will not be considered a responsible bidder. Upload Here:		Provide Own Spec Sheet		Provide Own Spec Sheet		Completed City's Form and Provided Own Spec Sheet			
Warranty		5 YEAR WARRANTY IS GIVEN OF ANY MALFUNCTION OF PRODUCT		"yes"		1 Year Warranty		"Warranties will be provided"	
Bidder's Client list for the past twelve (12) months is to be provided. Bidder shall furnish names, addresses, telephone numbers, and email addresses of representatives for each client on said list. The City will use this list to check references. If poor performance reports are received from any client on this list, the City may deem you non-responsive. If no client list is provided, the City may deem you non-responsive.		Provided		Provided		Provided			
Lead Time		Less Than 30 Days		21 Calendar Days		55-75 days ARO		45 Days	

**Agenda Sheet for City Council:****Committee:** PIES **Date:** 05/20/2024**Committee Agenda type:** Consent**Date Rec'd**

5/20/2024

**Clerk's File #**

OPR 2024-0451

**Cross Ref #****Project #****Council Meeting Date:** 06/10/2024**Submitting Dept**

STREETS

**Bid #**

ITB 6090-24

**Contact Name/Phone**

CLINT HARRIS 625-7744

**Requisition #**

VB

**Contact E-Mail**

CEHARRIS@SPOKANECITY.ORG

**Agenda Item Type**

Purchase w/o Contract

**Council Sponsor(s)**

BWILKERSON JBINGLE KKLITZKE

**Agenda Item Name**

1100 - STREETS RECTANGULAR RAPID FLASHING BEACONS

**Agenda Wording**

The Street Department is seeking approval for the purchase of rectangular rapid flashing beacons (RRFBs) at a cost not to exceed \$92,000.00.

**Summary (Background)**

This contract, awarded via bid (ITB 6090-24) to Western Systems Inc. (Everett, WA) will be the for five years, beginning upon acceptance date. RRFBs are traffic signaling devices used to provide signaled pedestrian crossing across roadways.

Lease? NO

Grant related? NO

Public Works? NO

**Fiscal Impact**

Approved in Current Year Budget? YES

Total Cost

\$ 460,000.00

Current Year Cost

\$ 92,000.00

Subsequent Year(s) Cost

\$ 92,000.00/year for 2025-2029

**Narrative****Amount****Budget Account**

Expense

\$ 92,000.00

# 1100-21400-42640-53210-99999

Select

\$

#

Select

\$

#

Select

\$

#

\$

#

\$

#



**Continuation of Wording, Summary, Approvals, and Distribution**

**Agenda Wording**

**Summary (Background)**

**Approvals**

<b><u>Dept Head</u></b>	HARRIS, CLINT E.
<b><u>Division Director</u></b>	FEIST, MARLENE
<b><u>Accounting Manager</u></b>	ORLOB, KIMBERLY
<b><u>Legal</u></b>	HARRINGTON,
<b><u>For the Mayor</u></b>	PICCOLO, MIKE

**Additional Approvals**

<b><u>PURCHASING</u></b>	PRINCE, THEA

**Distribution List**

Holton Ferguson, hferguson@westernsystemsinc.com	ceharris@spokanecity.org
jwthomas@spokanecity.org	gokihara@spokanecity.org
bvasecka@spokanecity.org	jklapp@spokanecity.org
rrinderle@spokanecity.org	streetaccounting@spokanecity.org
tprince@spokanecity.org	



## Committee Agenda Sheet

### Public Infrastructure, Environment & Sustainability Committee

<b>Committee Date</b>	05/20/2024
<b>Submitting Department</b>	Streets
<b>Contact Name</b>	Clint Harris
<b>Contact Email &amp; Phone</b>	<a href="mailto:ceharris@spokanecity.org">ceharris@spokanecity.org</a> , 509-625-7744
<b>Council Sponsor(s)</b>	<u>Wilkerson, Bingle, Klitzke</u>
<b>Select Agenda Item Type</b>	<input checked="" type="checkbox"/> Consent <input type="checkbox"/> Discussion    Time Requested:
<b>Agenda Item Name</b>	1100 – Rectangular Rapid Flashing Beacons
<b>Proposed Council Action</b>	<input checked="" type="checkbox"/> Approval to proceed to Legislative Agenda <input type="checkbox"/> Information Only
<b>Summary (Background)</b>	<p>The Street Department is seeking approval for the purchase of rectangular rapid flashing beacons (RRFBs) at a cost not to exceed \$92,000.00. This contract, awarded via bid (ITB6090-24) to Western Systems Inc. will be the for five years, beginning upon acceptance date.</p> <p>RRFBs are traffic signaling devices used to provide signaled pedestrian crossing across roadways.</p>
<b>Summary (Background)</b>	<p>*use the Fiscal Impact box below for relevant financial information</p>
<p><b>Fiscal Impact</b> \$92,000.00</p> <p><b>Approved in current year budget?</b>    <input checked="" type="checkbox"/> Yes    <input type="checkbox"/> No    <input type="checkbox"/> N/A</p> <p>Total Cost: <u>92,000.00</u></p> <p>    Current year cost: 92,000.00</p> <p>    Subsequent year(s) cost: 92,000/year for up to 4 extension years if renewed.</p>	
<p><b>Narrative:</b> Please provide financial due diligence review, as applicable, such as number and type of positions, grant match requirements, summary type details (personnel, maintenance and supplies, capital, revenue), impact on rates, fees, or future shared revenue</p>	
<p><b>Funding Source</b>            <input type="checkbox"/> One-time    <input checked="" type="checkbox"/> Recurring    <input type="checkbox"/> N/A</p> <p>Specify funding source: Program revenue</p> <p>Is this funding source sustainable for future years, months, etc? Yes</p>	
<p><b>Expense Occurrence</b>    <input type="checkbox"/> One-time    <input checked="" type="checkbox"/> Recurring    <input type="checkbox"/> N/A</p> <p>Other budget impacts: (revenue generating, match requirements, etc.)</p>	
<b>Operations Impacts</b> (If N/A, please give a brief description as to why)	
<p>What impacts would the proposal have on historically excluded communities? N/A</p> <p>These traffic signal devices are installed based on traffic and pedestrian data and are used to address conditions of safe pedestrian crossing in the City</p>	
<p>How will data be collected, analyzed, and reported concerning the effect of the program/policy by racial, ethnic, gender identity, national origin, income level, disability, sexual orientation, or other existing disparities?</p> <p>N/A These traffic signal devices are installed based on traffic and pedestrian data and are used to address conditions of safe pedestrian crossing in the City.</p>	

How will data be collected regarding the effectiveness of this program, policy or product to ensure it is the right solution?

These traffic signal devices are installed based on traffic and pedestrian data and are used to address conditions of safe pedestrian crossing in the City

Describe how this proposal aligns with current City Policies, including the Comprehensive Plan, Sustainability Action Plan, Capital Improvement Program, Neighborhood Master Plans, Council Resolutions, and others?

N/A

These traffic signal devices are installed based on traffic and pedestrian data and are used to address conditions of safe pedestrian crossing in the City



CITY OF SPOKANE  
 Nelson Center  
 Purchasing  
 PHONE 509 625 6527

**RFQ 6094-24 Carmina Technologies Rectangular Rapid Flashing Beacons As-Needed, No Or-Equals**

Annual estimated quantities are for the purpose of comparing bids on a uniform basis. Payment will be made only for quantities actually ordered, delivered, and accepted, whether greater or less than the stated amounts.

**CONTRACT PERIOD**

Term of Value Blanket Order: Value Blanket Order resulting from this ITB will be for a five year period, beginning approximately June 1, 2024, and terminate on May 31, 2029 . The total contract period not to exceed five (5) years. The Vendor’s prices shall be firm throughout the first year of the contract period. Pricing can be requested annually on the anniversary of the award with justification.

VENDOR		Western Systems Inc	
Item	Annual Estimated Qty	Unit price	Extended Price
Spec’d Carmina Technologies Rectangular Rapid Flashing Beacon per technical specification sheet ITB 6090-24. Unit Pricing Should Not Include Tax. Unit Pricing “Should” Include Freight. Unit Pricing shall be firm for 12 months from bid due date. Pricing adjustment will be considered on the anniversary of the award based on vendor providing back up documentation. Enter Unit Price Each:	14	\$5,509.48	\$77,132.72
Subtotal		\$77,132.72	
Tax 9%		\$6,941.94	
<b>Extended Total</b>		<b>\$84,074.66</b>	
<b>Lead Time</b>		45 - 60 Calendar Days	

**Agenda Sheet for City Council:****Committee:** PIES **Date:** 05/20/2024**Committee Agenda type:** Consent**Date Rec'd**

5/20/2024

**Clerk's File #**

OPR 2024-0452

**Cross Ref #**

OPR 2024-0453

**Project #****Council Meeting Date:** 06/10/2024**Submitting Dept**

STREETS

**Bid #****Contact Name/Phone**

CLINT HARRIS 625-7744

**Requisition #**

VB

**Contact E-Mail**

CEHARRIS@SPOKANECITY.ORG

**Agenda Item Type**

Purchase w/o Contract

**Council Sponsor(s)**

BWILKERSON JBINGLE KKLITZKE

**Agenda Item Name**

1100 - STREETS TRAFFIC PAINT

**Agenda Wording**

The Street Department is seeking approval to purchase Traffic paint at a cost not to exceed \$150,000.00.

**Summary (Background)**

This contract awarded via bid (ITB 6096-24) to Ennis-Flint Inc. (Greensboro, NC)(OPR 2024-0452) and Aramsco Inc. (Paulsboro, NJ)(OPR 2024-0453) will be for five years, with the first year beginning on July 15, 2024. Traffic paint is used for lane lines, marked crossings, and other pavement markings essential to roadway safety.

Lease? NO

Grant related? NO

Public Works? NO

**Fiscal Impact**

Approved in Current Year Budget? YES

Total Cost \$ 750,000.00

Current Year Cost \$ 150,000.00

Subsequent Year(s) Cost \$ 150,000.00/year for 2025-2029

**Narrative****Amount****Budget Account**

Expense \$ 150,000.00

# 1100-21400-42640-53210-99999

Select \$

#

Select \$

#

Select \$

#

\$

#

\$

#



**Continuation of Wording, Summary, Approvals, and Distribution**

**Agenda Wording**

**Summary (Background)**

**Approvals**

<b><u>Dept Head</u></b>	HARRIS, CLINT E.
<b><u>Division Director</u></b>	FEIST, MARLENE
<b><u>Accounting Manager</u></b>	ORLOB, KIMBERLY
<b><u>Legal</u></b>	HARRINGTON,
<b><u>For the Mayor</u></b>	PICCOLO, MIKE

**Additional Approvals**

**Distribution List**

Crystal Gentry, dl-ts-contracts@ppg.com	Janice Cornish, trafficsafety@aramsco.com
ceharris@spokanecity.org	jwthomas@spokanecity.org
meveland@spokanecity.org	rlynch@spokanecity.org
jklapp@spokanecity.org	rrinderle@spokanecity.org
streetaccounting@spokanecity.org	tprince@spokanecity.org

## Committee Agenda Sheet

### Public Infrastructure, Environment & Sustainability Committee

<b>Committee Date</b>	05/20/2024
<b>Submitting Department</b>	Streets
<b>Contact Name</b>	Clint Harris
<b>Contact Email &amp; Phone</b>	<a href="mailto:ceharris@spokanecity.org">ceharris@spokanecity.org</a> , 509-625-7744
<b>Council Sponsor(s)</b>	<u>Wilkerson, Bingle, Klitzke</u>
<b>Select Agenda Item Type</b>	<input checked="" type="checkbox"/> Consent <input type="checkbox"/> Discussion    Time Requested:
<b>Agenda Item Name</b>	1100 – Street Department Traffic Paint
<b>Proposed Council Action</b>	<input checked="" type="checkbox"/> Approval to proceed to Legislative Agenda <input type="checkbox"/> Information Only
<b>Summary (Background)</b>	<p>*use the Fiscal Impact box below for relevant financial information</p> <p>The Street Department is seeking approval to purchase Traffic paint at a cost not to exceed \$150,000.00 annually. This contract awarded via bid (ITB 6096-24) to Ennis-Flint Inc. and Aramsco Inc. will be for five years, with the first year beginning on July 15, 2024.</p> <p>Traffic paint is used for lane lines, marked crossings, and other pavement markings essential to roadway safety.</p>
<b>Fiscal Impact</b> \$150,000.00	
<b>Approved in current year budget?</b>	<input checked="" type="checkbox"/> Yes <input type="checkbox"/> No <input type="checkbox"/> N/A
Total Cost: <u>\$150,000.00</u>	
Current year cost: \$150,00.0	
Subsequent year(s) cost: \$150,000.00/year for up to 4 extension years if renewed	
<b>Narrative:</b> Please provide financial due diligence review, as applicable, such as number and type of positions, grant match requirements, summary type details (personnel, maintenance and supplies, capital, revenue), impact on rates, fees, or future shared revenue	
<b>Funding Source</b>	<input type="checkbox"/> One-time <input checked="" type="checkbox"/> Recurring <input type="checkbox"/> N/A
Specify funding source: Program revenue	
Is this funding source sustainable for future years, months, etc? <a href="#">Click or tap here to enter text.</a>	
<b>Expense Occurrence</b>	<input type="checkbox"/> One-time <input checked="" type="checkbox"/> Recurring <input type="checkbox"/> N/A
Other budget impacts: (revenue generating, match requirements, etc.) N/A	
<b>Operations Impacts</b> (If N/A, please give a brief description as to why)	
What impacts would the proposal have on historically excluded communities? N/A	
<u>Traffic paint is used based upon existing road marking conditions and their maintenance needs</u>	
How will data be collected, analyzed, and reported concerning the effect of the program/policy by racial, ethnic, gender identity, national origin, income level, disability, sexual orientation, or other existing disparities? N/A	
<u>Traffic paint is used based upon existing road marking conditions and their maintenance needs</u>	

How will data be collected regarding the effectiveness of this program, policy or product to ensure it is the right solution? N/A

Traffic paint is used based upon existing road marking conditions and their maintenance needs

Describe how this proposal aligns with current City Policies, including the Comprehensive Plan, Sustainability Action Plan, Capital Improvement Program, Neighborhood Master Plans, Council Resolutions, and others? N/A

Traffic paint is used based upon existing road marking conditions and their maintenance needs



CITY OF SPOKANE

Nelson Center

Purchasing

PHONE 509 625 6527

**ITB 6117-24 PERFORMED THERMOPLASTIC, As-Needed**

Annual Estimated quantities are for the purpose of comparing bids on a uniform basis. Payment will be made only for quantities actually ordered, delivered and accepted, whether greater or less than the stated amounts.

Pricing submitted on "Pricing Page" must be a firm throughout the first year of the Value Blanket Period. Pricing adjustments can be requested annually on the anniversary of award with justification.

Part numbers shown are Ennis-Flint, and are used for reference only.

"ALL" FREIGHT/SHIPPING IS THE RESPONSIBILITY OF THE WINNING VENDOR, as stated in bid.

VENDOR:			ENNIS-Flint, Inc.		Geveko Markings Inc		Rodda Paint	
Description	Unit	Annual Est. Qty	Unit Price	Extended	Unit Price	Extended	Unit Price	Extended
<b>ITEMS IN 125 MIL YELLOW</b>								
4" X 36" (90' LF PER PACK), #PM600101	PKG	15	\$70.11	\$1,051.65	\$91.38	\$1,370.70	\$109.40	\$1,641.00
<b>ITEMS IN 125 MIL WHITE</b>								
4" X 36" (90' LF PER PACK), #PM600100	PKG	1	\$65.45	\$65.45	\$93.07	\$93.07	\$103.40	\$103.40
6" X 36" (60' LF PER PACK), #8432061	PKG	1	\$65.45	\$65.45	\$93.07	\$93.07	\$96.20	\$96.20
8" X 24" (60' LF PER PACK), #8433062	PKG	50	\$87.26	\$4,363.00	\$113.73	\$5,686.50	\$96.20	\$4,810.00
8" X 36" (45' LF PER PACK), #PM600102	PKG	150	\$65.45	\$9,817.50	\$85.31	\$12,796.50	\$103.20	\$15,480.00
24" X 36" (15' LF PER PACK), #8430566	PKG	50	\$65.45	\$3,272.50	\$85.31	\$4,265.50	\$103.40	\$5,170.00
STRAIGHT ARROW, WA. STATE LOW SPEED TYPE 1S (2 PER PACK), #83302275	PKG	10	\$69.06	\$690.60	\$85.90	\$859.00	\$123.60	\$1,236.00
LEFT ARROW, WA. STATE LOW SPEED TYPE 2SL (2 PER PACK), #83302276L	PKG	10	\$66.57	\$665.70	\$82.82	\$828.20	\$110.00	\$1,100.00
RIGHT ARROW, WA. STATE LOW SPEED TYPE 2SR (2 PER PACK), #83302276R	PKG	10	\$66.57	\$665.70	\$82.82	\$828.20	\$110.00	\$1,100.00
COMBI LEFT ARROW, WA. STATE LOW SPEED TYPE 3SL (1 PER PACK), #83301277L	EA	10	\$63.53	\$635.30	\$91.18	\$911.80	\$129.20	\$1,292.00
COMBI RIGHT ARROW, WA. STATE LOW SPEED TYPE 3SR (1 PER PACK), #83301277R	EA	1	\$63.53	\$63.53	\$91.18	\$91.18	\$129.20	\$129.20
COMBI LEFT/ RIGHT ARROW, WA. STATE LOW SPEED TYPE 4S (1 PER PACK)	EA	1	\$54.88	\$54.88	\$78.82	\$78.82	\$128.60	\$128.60
LANE REDUCTION ARROW, LEFT, WA. STATE LOW SPEED TYPE 6SL, #83301274L	EA	1	\$68.18	\$68.18	\$97.97	\$97.97	\$277.20	\$277.20
LANE REDUCTION ARROW, RIGHT, WA. STATE LOW SPEED TYPE 6SR, #83301274R	EA	1	\$68.18	\$68.18	\$97.97	\$97.97	\$277.20	\$277.20
COMBI LEFT/ STRAIGHT/ RIGHT ARROW, WA. STATE LOW SPEED TYPE 7S (1 PER PACK)	EA	1	\$89.15	\$89.15	\$273.28	\$273.28	\$342.00	\$342.00
ROUNDAABOUT ARROW, WA. STATE TYPE TC	EA	1	\$89.32	\$89.32	\$167.17	\$167.17	\$267.60	\$267.60
ROUNDAABOUT ARROW, WA. STATE TYPE LTC	EA	1	\$116.48	\$116.48	\$227.96	\$227.96	\$356.40	\$356.40
ROUNDAABOUT ARROW, WA. STATE TYPE TRC	EA	1	\$111.09	\$111.09	\$212.76	\$212.76	\$356.40	\$356.40
ROUNDAABOUT ARROW, WA. STATE TYPE LTRC	EA	1	\$138.15	\$138.15	\$273.50	\$273.50	\$445.20	\$445.20
ROUNDAABOUT ARROW, WA. STATE TYPE LC	EA	1	\$87.01	\$87.01	\$136.77	\$136.77	\$267.60	\$267.60
"ONLY", #8130102	EA	2	\$98.07	\$196.14	\$153.27	\$306.54	\$154.80	\$309.60



"BUS", #8130117	EA	2	\$80.85	\$161.70	\$126.36	\$252.72	\$127.20	\$254.40
"R X R" KIT, NARROW, FHWA	EA	4	\$187.74	\$750.96	\$248.78	\$995.12	\$296.40	\$1,185.60
<b>ITEMS IN 90 MIL WHITE</b>								
BICYCLE RIDER (5 PER PACK), #PM602006L	PKG	1	\$297.15	\$297.15	\$464.40	\$464.40	\$471.60	\$471.60
BIKE LANE STRAIGHT ARROW (5 PER PACK), #PM602005-5PK	PKG	1	\$127.09	\$127.09	\$79.42	\$79.42	\$201.60	\$201.60
SHARED LANE SYMBOL #PM600833L	EA	10	\$152.78	\$1,527.80	\$202.45	\$2,024.50	\$250.80	\$2,508.00
<b>ITEMS IN 125 MIL, BLACK</b>								
CONTRASTING RETROFIT KIT FOR WA. STATE LOW SPEED TYPE 1S (2 PER PACK)	PKG	10	\$43.93	\$439.30	\$21.36	\$213.60	\$188.40	\$1,884.00
CONTRASTING RETROFIT KIT FOR WA. STATE LOW SPEED TYPE 2SL (2 PER PACK)	PKG	10	\$42.35	\$423.50	\$24.67	\$246.70	\$172.80	\$1,728.00
CONTRASTING RETROFIT KIT FOR WA. STATE LOW SPEED TYPE 2SR (2 PER PACK)	PKG	10	\$42.35	\$423.50	\$24.67	\$246.70	\$172.80	\$1,728.00
CONTRASTING RETROFIT KIT FOR WA. STATE LOW SPEED TYPE 3SL (1 PER PACK)	EA	10	\$90.30	\$903.00	\$37.80	\$378.00	\$194.40	\$1,944.00
CONTRASTING RETROFIT KIT FOR WA. STATE LOW SPEED TYPE 3SR (1 PER PACK)	EA	10	\$90.30	\$903.00	\$37.80	\$378.00	\$194.40	\$1,944.00
CONTRASTING RETROFIT KIT FOR "ONLY"	EA	2	\$45.36	\$90.72	\$49.74	\$99.48	\$170.40	\$340.80
CONTRASTING RETROFIT KIT FOR "BUS"	EA	2	\$34.09	\$68.18	\$29.63	\$59.26	\$158.40	\$316.80
<b>ITEMS IN 90 MIL GREEN</b>								
6" X 36" (60' LF PER PACK)	PKG	2	\$77.91	\$155.82	\$121.76	\$243.52	\$109.20	\$218.40
24" X 36" (15' LF PER PACK)	PKG	2	\$77.91	\$155.82	\$121.76	\$243.52	\$109.20	\$218.40
<b>PCC Sealer</b>								
SEALER FOR APPLICATIONS ON CONCRETE	GAL	5	\$203.60	\$1,018.00	Did not complete revised pricing page so pricing for item was not bid		\$28.80	\$144.00
<b>Subtotal</b>			<b>\$29,820.50</b>		<b>\$35,621.40</b>		<b>\$50,273.20</b>	
<b>WA State Sales Tax (9%)</b>			<b>\$2,683.85</b>		<b>\$3,205.93</b>		<b>\$4,524.59</b>	
<b>Extended Total</b>			<b>\$32,504.35</b>		<b>\$38,827.33</b>		<b>\$54,797.79</b>	
<b>Bidder MUST complete and upload Technical Specification Sheet. Upload here, if not uploaded bid may be considered non-responsive.</b>			<b>Provided</b>		<b>Provided</b>		<b>Provided</b>	
<b>Catalog Submitted With Quote</b>			<b>Provided</b>		<b>Not Provided</b>		<b>Not Provided</b>	
<b>Any items not shown on the PRICING SHEET will be priced at ___% below list price in submitted catalog.</b>			<b>30% BELOW</b>		<b>39% BELOW</b>		<b>25% BELOW</b>	



**Agenda Sheet for City Council:**

**Committee:** PIES **Date:** 05/20/2024

**Committee Agenda type:** Consent

**Date Rec'd** 5/20/2024

**Clerk's File #** OPR 2024-0453

**Cross Ref #** OPR 2024-0452

**Project #**

**Council Meeting Date:** 06/10/2024

<b>Submitting Dept</b>	STREETS	<b>Bid #</b>	
------------------------	---------	--------------	--

<b>Contact Name/Phone</b>	CLINT HARRIS 625-7744	<b>Requisition #</b>	VB
---------------------------	-----------------------	----------------------	----

<b>Contact E-Mail</b>	CEHARRIS@SPOKANECITY.ORG		
-----------------------	--------------------------	--	--

<b>Agenda Item Type</b>	Purchase w/o Contract		
-------------------------	-----------------------	--	--

<b>Council Sponsor(s)</b>	BWILKERSON JBINGLE KKLITZKE		
---------------------------	-----------------------------	--	--

<b>Agenda Item Name</b>	1100 - STREETS TRAFFIC PAINT		
-------------------------	------------------------------	--	--

**Agenda Wording**

The Street Department is seeking approval to purchase Traffic paint at a cost not to exceed \$150,000.00.

**Summary (Background)**

This contract awarded via bid (ITB 6096-24) to Ennis-Flint Inc. (Greensboro, NC)(OPR 2024-0452) and Aramsco Inc. (Paulsboro, NJ)(OPR 2024-0453) will be for five years, with the first year beginning on July 15, 2024. Traffic paint is used for lane lines, marked crossings, and other pavement markings essential to roadway safety.

Lease? NO Grant related? NO Public Works? NO

**Fiscal Impact**

Approved in Current Year Budget? YES

Total Cost \$ 750,000.00

Current Year Cost \$ 150,000.00

Subsequent Year(s) Cost \$ 150,000.00/year for 2025-2029

**Narrative**

**Amount**

**Budget Account**

Expense	\$ 150,000.00	# 1100-21400-42640-53210-99999
Select	\$	#
Select	\$	#
Select	\$	#
	\$	#
	\$	#



**Continuation of Wording, Summary, Approvals, and Distribution**

**Agenda Wording**

**Summary (Background)**

**Approvals**

<b><u>Dept Head</u></b>	HARRIS, CLINT E.
<b><u>Division Director</u></b>	FEIST, MARLENE
<b><u>Accounting Manager</u></b>	ORLOB, KIMBERLY
<b><u>Legal</u></b>	HARRINGTON,
<b><u>For the Mayor</u></b>	PICCOLO, MIKE

**Additional Approvals**

**Distribution List**

Crystal Gentry, dl-ts-contracts@ppg.com	Janice Cornish, trafficsafety@aramsco.com
ceharris@spokanecity.org	jwthomas@spokanecity.org
meveland@spokanecity.org	rlynch@spokanecity.org
jklapp@spokanecity.org	rrinderle@spokanecity.org
streetaccounting@spokanecity.org	tprince@spokanecity.org

## Committee Agenda Sheet

### Public Infrastructure, Environment & Sustainability Committee

<b>Committee Date</b>	05/20/2024
<b>Submitting Department</b>	Streets
<b>Contact Name</b>	Clint Harris
<b>Contact Email &amp; Phone</b>	<a href="mailto:ceharris@spokanecity.org">ceharris@spokanecity.org</a> , 509-625-7744
<b>Council Sponsor(s)</b>	<u>Wilkerson, Bingle, Klitzke</u>
<b>Select Agenda Item Type</b>	<input checked="" type="checkbox"/> Consent <input type="checkbox"/> Discussion    Time Requested:
<b>Agenda Item Name</b>	1100 – Street Department Traffic Paint
<b>Proposed Council Action</b>	<input checked="" type="checkbox"/> Approval to proceed to Legislative Agenda <input type="checkbox"/> Information Only
<b>Summary (Background)</b>	<p>*use the Fiscal Impact box below for relevant financial information</p> <p>The Street Department is seeking approval to purchase Traffic paint at a cost not to exceed \$150,000.00 annually. This contract awarded via bid (ITB 6096-24) to Ennis-Flint Inc. and Aramsco Inc. will be for five years, with the first year beginning on July 15, 2024.</p> <p>Traffic paint is used for lane lines, marked crossings, and other pavement markings essential to roadway safety.</p>
<b>Fiscal Impact</b> \$150,000.00	
<b>Approved in current year budget?</b>	<input checked="" type="checkbox"/> Yes <input type="checkbox"/> No <input type="checkbox"/> N/A
Total Cost: <u>\$150,000.00</u>	
Current year cost: \$150,00.0	
Subsequent year(s) cost: \$150,000.00/year for up to 4 extension years if renewed	
<b>Narrative:</b> Please provide financial due diligence review, as applicable, such as number and type of positions, grant match requirements, summary type details (personnel, maintenance and supplies, capital, revenue), impact on rates, fees, or future shared revenue	
<b>Funding Source</b>	<input type="checkbox"/> One-time <input checked="" type="checkbox"/> Recurring <input type="checkbox"/> N/A
Specify funding source: Program revenue	
Is this funding source sustainable for future years, months, etc? <a href="#">Click or tap here to enter text.</a>	
<b>Expense Occurrence</b>	<input type="checkbox"/> One-time <input checked="" type="checkbox"/> Recurring <input type="checkbox"/> N/A
Other budget impacts: (revenue generating, match requirements, etc.) N/A	
<b>Operations Impacts</b> (If N/A, please give a brief description as to why)	
What impacts would the proposal have on historically excluded communities? N/A	
<u>Traffic paint is used based upon existing road marking conditions and their maintenance needs</u>	
How will data be collected, analyzed, and reported concerning the effect of the program/policy by racial, ethnic, gender identity, national origin, income level, disability, sexual orientation, or other existing disparities? N/A	
<u>Traffic paint is used based upon existing road marking conditions and their maintenance needs</u>	

How will data be collected regarding the effectiveness of this program, policy or product to ensure it is the right solution? N/A

Traffic paint is used based upon existing road marking conditions and their maintenance needs

Describe how this proposal aligns with current City Policies, including the Comprehensive Plan, Sustainability Action Plan, Capital Improvement Program, Neighborhood Master Plans, Council Resolutions, and others? N/A

Traffic paint is used based upon existing road marking conditions and their maintenance needs



CITY OF SPOKANE

Nelson Center

Purchasing

PHONE 509 625 6527

**ITB 6117-24 PERFORMED THERMOPLASTIC, As-Needed**

Annual Estimated quantities are for the purpose of comparing bids on a uniform basis. Payment will be made only for quantities actually ordered, delivered and accepted, whether greater or less than the stated amounts.

Pricing submitted on "Pricing Page" must be a firm throughout the first year of the Value Blanket Period. Pricing adjustments can be requested annually on the anniversary of award with justification.

Part numbers shown are Ennis-Flint, and are used for reference only.

"ALL" FREIGHT/SHIPPING IS THE RESPONSIBILITY OF THE WINNING VENDOR, as stated in bid.

VENDOR:			ENNIS-Flint, Inc.		Geveko Markings Inc		Rodda Paint	
Description	Unit	Annual Est. Qty	Unit Price	Extended	Unit Price	Extended	Unit Price	Extended
<b>ITEMS IN 125 MIL YELLOW</b>								
4" X 36" (90' LF PER PACK), #PM600101	PKG	15	\$70.11	\$1,051.65	\$91.38	\$1,370.70	\$109.40	\$1,641.00
<b>ITEMS IN 125 MIL WHITE</b>								
4" X 36" (90' LF PER PACK), #PM600100	PKG	1	\$65.45	\$65.45	\$93.07	\$93.07	\$103.40	\$103.40
6" X 36" (60' LF PER PACK), #8432061	PKG	1	\$65.45	\$65.45	\$93.07	\$93.07	\$96.20	\$96.20
8" X 24" (60' LF PER PACK), #8433062	PKG	50	\$87.26	\$4,363.00	\$113.73	\$5,686.50	\$96.20	\$4,810.00
8" X 36" (45' LF PER PACK), #PM600102	PKG	150	\$65.45	\$9,817.50	\$85.31	\$12,796.50	\$103.20	\$15,480.00
24" X 36" (15' LF PER PACK), #8430566	PKG	50	\$65.45	\$3,272.50	\$85.31	\$4,265.50	\$103.40	\$5,170.00
STRAIGHT ARROW, WA. STATE LOW SPEED TYPE 1S (2 PER PACK), #83302275	PKG	10	\$69.06	\$690.60	\$85.90	\$859.00	\$123.60	\$1,236.00
LEFT ARROW, WA. STATE LOW SPEED TYPE 2SL (2 PER PACK), #83302276L	PKG	10	\$66.57	\$665.70	\$82.82	\$828.20	\$110.00	\$1,100.00
RIGHT ARROW, WA. STATE LOW SPEED TYPE 2SR (2 PER PACK), #83302276R	PKG	10	\$66.57	\$665.70	\$82.82	\$828.20	\$110.00	\$1,100.00
COMBI LEFT ARROW, WA. STATE LOW SPEED TYPE 3SL (1 PER PACK), #83301277L	EA	10	\$63.53	\$635.30	\$91.18	\$911.80	\$129.20	\$1,292.00
COMBI RIGHT ARROW, WA. STATE LOW SPEED TYPE 3SR (1 PER PACK), #83301277R	EA	1	\$63.53	\$63.53	\$91.18	\$91.18	\$129.20	\$129.20
COMBI LEFT/ RIGHT ARROW, WA. STATE LOW SPEED TYPE 4S (1 PER PACK)	EA	1	\$54.88	\$54.88	\$78.82	\$78.82	\$128.60	\$128.60
LANE REDUCTION ARROW, LEFT, WA. STATE LOW SPEED TYPE 6SL, #83301274L	EA	1	\$68.18	\$68.18	\$97.97	\$97.97	\$277.20	\$277.20
LANE REDUCTION ARROW, RIGHT, WA. STATE LOW SPEED TYPE 6SR, #83301274R	EA	1	\$68.18	\$68.18	\$97.97	\$97.97	\$277.20	\$277.20
COMBI LEFT/ STRAIGHT/ RIGHT ARROW, WA. STATE LOW SPEED TYPE 7S (1 PER PACK)	EA	1	\$89.15	\$89.15	\$273.28	\$273.28	\$342.00	\$342.00
ROUNDAABOUT ARROW, WA. STATE TYPE TC	EA	1	\$89.32	\$89.32	\$167.17	\$167.17	\$267.60	\$267.60
ROUNDAABOUT ARROW, WA. STATE TYPE LTC	EA	1	\$116.48	\$116.48	\$227.96	\$227.96	\$356.40	\$356.40
ROUNDAABOUT ARROW, WA. STATE TYPE TRC	EA	1	\$111.09	\$111.09	\$212.76	\$212.76	\$356.40	\$356.40
ROUNDAABOUT ARROW, WA. STATE TYPE LTRC	EA	1	\$138.15	\$138.15	\$273.50	\$273.50	\$445.20	\$445.20
ROUNDAABOUT ARROW, WA. STATE TYPE LC	EA	1	\$87.01	\$87.01	\$136.77	\$136.77	\$267.60	\$267.60
"ONLY", #8130102	EA	2	\$98.07	\$196.14	\$153.27	\$306.54	\$154.80	\$309.60

"BUS", #8130117	EA	2	\$80.85	\$161.70	\$126.36	\$252.72	\$127.20	\$254.40
"R X R" KIT, NARROW, FHWA	EA	4	\$187.74	\$750.96	\$248.78	\$995.12	\$296.40	\$1,185.60
<b>ITEMS IN 90 MIL WHITE</b>								
BICYCLE RIDER (5 PER PACK), #PM602006L	PKG	1	\$297.15	\$297.15	\$464.40	\$464.40	\$471.60	\$471.60
BIKE LANE STRAIGHT ARROW (5 PER PACK), #PM602005-5PK	PKG	1	\$127.09	\$127.09	\$79.42	\$79.42	\$201.60	\$201.60
SHARED LANE SYMBOL #PM600833L	EA	10	\$152.78	\$1,527.80	\$202.45	\$2,024.50	\$250.80	\$2,508.00
<b>ITEMS IN 125 MIL, BLACK</b>								
CONTRASTING RETROFIT KIT FOR WA. STATE LOW SPEED TYPE 1S (2 PER PACK)	PKG	10	\$43.93	\$439.30	\$21.36	\$213.60	\$188.40	\$1,884.00
CONTRASTING RETROFIT KIT FOR WA. STATE LOW SPEED TYPE 2SL (2 PER PACK)	PKG	10	\$42.35	\$423.50	\$24.67	\$246.70	\$172.80	\$1,728.00
CONTRASTING RETROFIT KIT FOR WA. STATE LOW SPEED TYPE 2SR (2 PER PACK)	PKG	10	\$42.35	\$423.50	\$24.67	\$246.70	\$172.80	\$1,728.00
CONTRASTING RETROFIT KIT FOR WA. STATE LOW SPEED TYPE 3SL (1 PER PACK)	EA	10	\$90.30	\$903.00	\$37.80	\$378.00	\$194.40	\$1,944.00
CONTRASTING RETROFIT KIT FOR WA. STATE LOW SPEED TYPE 3SR (1 PER PACK)	EA	10	\$90.30	\$903.00	\$37.80	\$378.00	\$194.40	\$1,944.00
CONTRASTING RETROFIT KIT FOR "ONLY"	EA	2	\$45.36	\$90.72	\$49.74	\$99.48	\$170.40	\$340.80
CONTRASTING RETROFIT KIT FOR "BUS"	EA	2	\$34.09	\$68.18	\$29.63	\$59.26	\$158.40	\$316.80
<b>ITEMS IN 90 MIL GREEN</b>								
6" X 36" (60' LF PER PACK)	PKG	2	\$77.91	\$155.82	\$121.76	\$243.52	\$109.20	\$218.40
24" X 36" (15' LF PER PACK)	PKG	2	\$77.91	\$155.82	\$121.76	\$243.52	\$109.20	\$218.40
<b>PCC Sealer</b>								
SEALER FOR APPLICATIONS ON CONCRETE	GAL	5	\$203.60	\$1,018.00	Did not complete revised pricing page so pricing for item was not bid		\$28.80	\$144.00
<b>Subtotal</b>			<b>\$29,820.50</b>		<b>\$35,621.40</b>		<b>\$50,273.20</b>	
<b>WA State Sales Tax (9%)</b>			<b>\$2,683.85</b>		<b>\$3,205.93</b>		<b>\$4,524.59</b>	
<b>Extended Total</b>			<b>\$32,504.35</b>		<b>\$38,827.33</b>		<b>\$54,797.79</b>	
<b>Bidder MUST complete and upload Technical Specification Sheet. Upload here, If not uploaded bid may be considered non-responsive.</b>			<b>Provided</b>		<b>Provided</b>		<b>Provided</b>	
<b>Catalog Submitted With Quote</b>			<b>Provided</b>		<b>Not Provided</b>		<b>Not Provided</b>	
<b>Any items not shown on the PRICING SHEET will be priced at ___% below list price in submitted catalog.</b>			<b>30% BELOW</b>		<b>39% BELOW</b>		<b>25% BELOW</b>	



**Agenda Sheet for City Council:**

**Committee:** PIES **Date:** 05/20/2024

**Committee Agenda type:** Consent

**Date Rec'd** 5/20/2024

**Clerk's File #** OPR 2024-0454

**Cross Ref #** OPR 2024-0455

**Cross Ref #** OPR 2024-0456

**Council Meeting Date:** 06/10/2024

<b>Submitting Dept</b>	STREETS	<b>Bid #</b>	ITB 6098-24
------------------------	---------	--------------	-------------

<b>Contact Name/Phone</b>	CLINT HARRIS 625-7744	<b>Requisition #</b>	VB
---------------------------	-----------------------	----------------------	----

<b>Contact E-Mail</b>	CEHARRIS@SPOKANECITY.ORG		
-----------------------	--------------------------	--	--

<b>Agenda Item Type</b>	Purchase w/o Contract		
-------------------------	-----------------------	--	--

<b>Council Sponsor(s)</b>	BWILKERSON JBINGLE KKLITZKE		
---------------------------	-----------------------------	--	--

<b>Agenda Item Name</b>	1100 - ASPHALTIC MIXES		
-------------------------	------------------------	--	--

**Agenda Wording**

The Street Department is seeking approval for the purchase of asphaltic mixes at a cost not to exceed \$1,925,000.00 annually.

**Summary (Background)**

This contract, awarded via bid (ITB 6098-24) to Shamrock Paving, Inc. (Spokane)(OPR 2024-0454), Inland Asphalt Company (Spokane)(OPR 2024-0455), and Poe Asphalt Paving, Inc. (Spokane)(OPR 2024-0456) will begin June 2nd, 2024 and expire June 1st, 2029. This contract will be used by Streets, Sewer, Parks, and Water Depts.

Lease? NO Grant related? NO Public Works? NO

**Fiscal Impact**

Approved in Current Year Budget? YES

Total Cost	\$ 9,625,000.00
------------	-----------------

Current Year Cost	\$ 1,925,000.00
-------------------	-----------------

Subsequent Year(s) Cost	\$ 1,925,000.00/year for 2025-2029
-------------------------	------------------------------------

**Narrative**

**Amount**

**Budget Account**

Expense	\$ 1,925,000.00	# Various
Select	\$	#
Select	\$	#
Select	\$	#
	\$	#
	\$	#





**Continuation of Wording, Summary, Approvals, and Distribution**

**Agenda Wording**

**Summary (Background)**

**Approvals**

<b><u>Dept Head</u></b>	HARRIS, CLINT E.
<b><u>Division Director</u></b>	FEIST, MARLENE
<b><u>Accounting Manager</u></b>	ORLOB, KIMBERLY
<b><u>Legal</u></b>	HARRINGTON,
<b><u>For the Mayor</u></b>	PICCOLO, MIKE

**Additional Approvals**

<b><u>PURCHASING</u></b>	PRINCE, THEA

**Distribution List**

Jared Boucher, jared.boucher@inlandnw.com	Chuck Green, chuckg@shamrockpaving.us
Derek Helt, derek@poeasphalt.com	ceharris@spokanecity.org
jwthomas@spokanecity.org	jklapp@spokanecity.org
jdykes@spokanecity.org	rrinderle@spokanecity.org
streetaccounting@spokanecity.org	tprince@spokanecity.org

## Committee Agenda Sheet

### Public Infrastructure, Environment & Sustainability Committee

<b>Committee Date</b>	05/20/2024
<b>Submitting Department</b>	Streets
<b>Contact Name</b>	Clint Harris
<b>Contact Email &amp; Phone</b>	<a href="mailto:ceharris@spokanecity.org">ceharris@spokanecity.org</a> , 509-625-7744
<b>Council Sponsor(s)</b>	<u>Wilkerson, Bingle, Klitzke</u>
<b>Select Agenda Item Type</b>	<input checked="" type="checkbox"/> Consent <input type="checkbox"/> Discussion    Time Requested:
<b>Agenda Item Name</b>	1100 –Asphaltic Mixes
<b>Proposed Council Action</b>	<input checked="" type="checkbox"/> Approval to proceed to Legislative Agenda <input type="checkbox"/> Information Only
<b>Summary (Background)</b>  *use the Fiscal Impact box below for relevant financial information	<p>The Street Department is seeking approval for the purchase of asphaltic mixes at a cost not to exceed \$1,925,000.00 annually. This contract, awarded via bid (ITB 6098-24) to Shamrock Paving, Inland Asphalt, and Poe Asphalt Paving Inc. will begin June 2<sup>nd</sup>, 2024 and expire June 1<sup>st</sup>, 2029.</p> <p>This contract will be used by Streets, Sewer, Parks, and Water Depts.</p>
<b>Fiscal Impact</b>	\$1,925,000.00
<b>Approved in current year budget?</b>	<input checked="" type="checkbox"/> Yes <input type="checkbox"/> No <input type="checkbox"/> N/A
Total Cost:	<u>1,925,000.00</u>
Current year cost:	\$1,925,000.00
Subsequent year(s) cost:	1,925,000.00/year for each extension year
<b>Narrative:</b>	Please provide financial due diligence review, as applicable, such as number and type of positions, grant match requirements, summary type details (personnel, maintenance and supplies, capital, revenue), impact on rates, fees, or future shared revenue
<b>Funding Source</b>	<input type="checkbox"/> One-time <input checked="" type="checkbox"/> Recurring <input type="checkbox"/> N/A
Specify funding source:	Program revenue
Is this funding source sustainable for future years, months, etc?	Yes
<b>Expense Occurrence</b>	<input type="checkbox"/> One-time <input checked="" type="checkbox"/> Recurring <input type="checkbox"/> N/A
Other budget impacts:	(revenue generating, match requirements, etc.)
<b>Operations Impacts</b> (If N/A, please give a brief description as to why)	
What impacts would the proposal have on historically excluded communities? N/A	<u>Asphalt is a product used to maintain roadways across the City</u>
How will data be collected, analyzed, and reported concerning the effect of the program/policy by racial, ethnic, gender identity, national origin, income level, disability, sexual orientation, or other existing disparities? N/A	<u>Asphalt is a product used to maintain roadways across the City</u>
How will data be collected regarding the effectiveness of this program, policy or product to ensure it is the right solution? N/A	<u>Asphalt is a product used to maintain roadways across the City</u>

Describe how this proposal aligns with current City Policies, including the Comprehensive Plan, Sustainability Action Plan, Capital Improvement Program, Neighborhood Master Plans, Council Resolutions, and others? N/A  
Asphalt is a product used to maintain roadways across the City

ITEM / DESCRIPTION	INLAND ASPHALT					INLAND ASPHALT					SHAMROCK MANUFACTURING 110 N HAYFORD RD SPOKANE WA 99224					SHAMROCK MANUFACTURING 110 N HAYFORD RD SPOKANE WA 99224					POE ASPHALT PAVING INC 7090 S Grove Spokane WA 99224								
	Commercial 64-28 Oil	QPL 64-28 ER Oil	Commercial 70-28 Oil	QPL 70-28 ER OIL	Warm Mix Tech*	Commercial 64-28 Oil	QPL 64-28 ER Oil	Commercial 70-28 Oil	QPL 70-28 ER OIL	Warm Mix Tech*	Commercial 64-28 Oil	QPL 64-28 ER OIL	Commercial 70-28 Oil	QPL 70-28 ER Oil	Warm Mix Tech	Commercial 64-28 Oil	QPL 64-28 ER OIL	Commercial 70-28 Oil	QPL 70-28 ER Oil	Warm Mix Tech	Commercial 64-28 Oil	QPL 64-28 ER Oil	Commercial 70-28 Oil	QPL 70-28 ER OIL	Warm Mix Tech				
ITB 6098-25 ASPHALTIC MIXES	Perry Plant					Sullivan Plant					Shamrock Manufacturing Plant 1					Shamrock Manufacturing Plant 2					Grove Pt / Plant								
<b>Due to the volatility of this product, vendors will be allowed to provide updated pricing on the first of each</b>																													
ASPHALTIC MIXES	\$76.00	Do Not Carry	Do Not Carry	Do Not Carry	*	\$74.00	Do Not Carry	Do Not Carry	Do Not Carry	*	\$76.00	\$79.00	\$79.00	\$79.00	n/a	\$68.00	\$71.00	\$71.00	\$71.00	n/a	\$67.00	\$67.00	\$67.00	\$67.00	n/a				
HMA Class 1/2 Inch	\$79.00	Do Not Carry	Do Not Carry	Do Not Carry	*	\$77.00	Do Not Carry	Do Not Carry	Do Not Carry	*	\$79.00	\$82.00	\$82.00	\$82.00	n/a	\$71.00	\$74.00	\$74.00	\$74.00	n/a	\$70.00	\$70.00	\$70.00	\$70.00	n/a				
HMA Class 3/4 Inch	*No Additional Charge Call Ahead To Order					*No Additional Charge Call Ahead To Order					Virgin Mix (No Rap)	Virgin Mix (No Rap)	Virgin Mix (No Rap)			20% RAP	20% RAP	20% RAP	20% RAP	n/a									
Delivery Fees	\$ -					\$ -					\$ -					\$ -													
Other Fees	Sales Tax					Sales Tax					Sales Tax					Sales Tax													
<b>CALL 24 HOURS IN ADVANCE FOR ALL ORDERS</b>					<b>CALL 24 HOURS IN ADVANCE FOR ALL ORDERS</b>					<b>All Items - Virgin Mix - (no Rap)</b>					<b>All Items - 20% Rap</b>					<b>CALL 24 HOURS IN ADVANCE FOR ALL ORDERS</b>									
Facility:	Perry Plant #3 13302 N Perry, Spokane WA					Facility:	Sullivan Plant 1902 N Sullivan Rd., Spokane WA					Facility:	Shamrock Manufacturing Plant 1 110 N Hayford Rd., Spokane WA					Facility:	Shamrock Manufacturing Plant 2 12605 N Hayford Rd., Spokane WA					Facility:	Grove Pt / Plant 7909 S. Grove Rd Spokane WA				
7:00 am - 5:00 pm (Monday - Friday)					7:00 am - 5:00 pm (Monday - Friday)					7:00 am - 3:30 pm (Monday - Friday)					7:00 am - 3:30 pm (Monday - Friday)					7:00 am - 5:00 pm (Monday - Friday)									
Operating Hours Phone 509 979 7640					Operating Hours Phone 509 979 7640					Operating Hours Phone 509 244 2800					Operating Hours Phone 509 244 2800					Operating Hours Phone 509 244 8908									
After Hours Phone 509 979 7640					After Hours Phone 509 979 7640					After Hours Phone 509 244 2800					After Hours Phone 509 244 2800					After Hours Phone 509 780 2445									

**Agenda Sheet for City Council:****Committee:** PIES **Date:** 05/20/2024**Committee Agenda type:** Consent**Date Rec'd**

5/20/2024

**Clerk's File #**

OPR 2024-0455

**Cross Ref #**

OPR 2024-0454

**Cross Ref #**

OPR 2024-0456

**Council Meeting Date:** 06/10/2024**Submitting Dept**

STREETS

**Bid #**

ITB 6098-24

**Contact Name/Phone**

CLINT HARRIS 625-7744

**Requisition #**

VB

**Contact E-Mail**

CEHARRIS@SPOKANECITY.ORG

**Agenda Item Type**

Purchase w/o Contract

**Council Sponsor(s)**

BWILKERSON JBINGLE KKLITZKE

**Agenda Item Name**

1100 - ASPHALTIC MIXES

**Agenda Wording**

The Street Department is seeking approval for the purchase of asphaltic mixes at a cost not to exceed \$1,925,000.00 annually.

**Summary (Background)**

This contract, awarded via bid (ITB 6098-24) to Shamrock Paving, Inc. (Spokane)(OPR 2024-0454), **Inland Asphalt Company (Spokane)(OPR 2024-0455)**, and Poe Asphalt Paving, Inc. (Spokane)(OPR 2024-0456) will begin June 2nd, 2024 and expire June 1st, 2029. This contract will be used by Streets, Sewer, Parks, and Water Depts.

Lease? NO

Grant related? NO

Public Works? NO

**Fiscal Impact**

Approved in Current Year Budget? YES

Total Cost

\$ 9,625,000.00

Current Year Cost

\$ 1,925,000.00

Subsequent Year(s) Cost

\$ 1,925,000.00/year for 2025-2029

**Narrative****Amount****Budget Account**

Expense

\$ 1,925,000.00

# Various

Select

\$

#

Select

\$

#

Select

\$

#

\$

#

\$

#



**Continuation of Wording, Summary, Approvals, and Distribution**

**Agenda Wording**

**Summary (Background)**

**Approvals**

<b><u>Dept Head</u></b>	HARRIS, CLINT E.
<b><u>Division Director</u></b>	FEIST, MARLENE
<b><u>Accounting Manager</u></b>	ORLOB, KIMBERLY
<b><u>Legal</u></b>	HARRINGTON,
<b><u>For the Mayor</u></b>	PICCOLO, MIKE

**Additional Approvals**

<b><u>PURCHASING</u></b>	PRINCE, THEA

**Distribution List**

Jared Boucher, jared.boucher@inlandnw.com	Chuck Green, chuckg@shamrockpaving.us
Derek Helt, derek@poeasphalt.com	ceharris@spokanecity.org
jwthomas@spokanecity.org	jklapp@spokanecity.org
jdykes@spokanecity.org	rrinderle@spokanecity.org
streetaccounting@spokanecity.org	tprince@spokanecity.org

## Committee Agenda Sheet

### Public Infrastructure, Environment & Sustainability Committee

<b>Committee Date</b>	05/20/2024
<b>Submitting Department</b>	Streets
<b>Contact Name</b>	Clint Harris
<b>Contact Email &amp; Phone</b>	<a href="mailto:ceharris@spokanecity.org">ceharris@spokanecity.org</a> , 509-625-7744
<b>Council Sponsor(s)</b>	<u>Wilkerson, Bingle, Klitzke</u>
<b>Select Agenda Item Type</b>	<input checked="" type="checkbox"/> Consent <input type="checkbox"/> Discussion    Time Requested:
<b>Agenda Item Name</b>	1100 –Asphaltic Mixes
<b>Proposed Council Action</b>	<input checked="" type="checkbox"/> Approval to proceed to Legislative Agenda <input type="checkbox"/> Information Only
<b>Summary (Background)</b>  *use the Fiscal Impact box below for relevant financial information	<p>The Street Department is seeking approval for the purchase of asphaltic mixes at a cost not to exceed \$1,925,000.00 annually. This contract, awarded via bid (ITB 6098-24) to Shamrock Paving, Inland Asphalt, and Poe Asphalt Paving Inc. will begin June 2<sup>nd</sup>, 2024 and expire June 1<sup>st</sup>, 2029.</p> <p>This contract will be used by Streets, Sewer, Parks, and Water Depts.</p>
<b>Fiscal Impact</b>	\$1,925,000.00
<b>Approved in current year budget?</b>	<input checked="" type="checkbox"/> Yes <input type="checkbox"/> No <input type="checkbox"/> N/A
Total Cost:	<u>1,925,000.00</u>
Current year cost:	\$1,925,000.00
Subsequent year(s) cost:	1,925,000.00/year for each extension year
<b>Narrative:</b>	Please provide financial due diligence review, as applicable, such as number and type of positions, grant match requirements, summary type details (personnel, maintenance and supplies, capital, revenue), impact on rates, fees, or future shared revenue
<b>Funding Source</b>	<input type="checkbox"/> One-time <input checked="" type="checkbox"/> Recurring <input type="checkbox"/> N/A
Specify funding source:	Program revenue
Is this funding source sustainable for future years, months, etc?	Yes
<b>Expense Occurrence</b>	<input type="checkbox"/> One-time <input checked="" type="checkbox"/> Recurring <input type="checkbox"/> N/A
Other budget impacts:	(revenue generating, match requirements, etc.)
<b>Operations Impacts</b> (If N/A, please give a brief description as to why)	
What impacts would the proposal have on historically excluded communities? N/A	<u>Asphalt is a product used to maintain roadways across the City</u>
How will data be collected, analyzed, and reported concerning the effect of the program/policy by racial, ethnic, gender identity, national origin, income level, disability, sexual orientation, or other existing disparities? N/A	<u>Asphalt is a product used to maintain roadways across the City</u>
How will data be collected regarding the effectiveness of this program, policy or product to ensure it is the right solution? N/A	<u>Asphalt is a product used to maintain roadways across the City</u>

Describe how this proposal aligns with current City Policies, including the Comprehensive Plan, Sustainability Action Plan, Capital Improvement Program, Neighborhood Master Plans, Council Resolutions, and others? N/A  
Asphalt is a product used to maintain roadways across the City



ITEM / DESCRIPTION	INLAND ASPHALT					INLAND ASPHALT					SHAMROCK MANUFACTURING 110 N HAYFORD RD SPOKANE WA 99224					SHAMROCK MANUFACTURING 110 N HAYFORD RD SPOKANE WA 99224					POE ASPHALT PAVING INC 7090 S Grove Spokane WA 99224								
	Commercial 64-28 Oil	QPL 64-28 ER Oil	Commercial 70-28 Oil	QPL 70-28 ER OIL	Warm Mix Tech*	Commercial 64-28 Oil	QPL 64-28 ER Oil	Commercial 70-28 Oil	QPL 70-28 ER OIL	Warm Mix Tech*	Commercial 64-28 Oil	QPL 64-28 ER OIL	Commercial 70-28 Oil	QPL 70-28 ER Oil	Warm Mix Tech	Commercial 64-28 Oil	QPL 64-28 ER OIL	Commercial 70-28 Oil	QPL 70-28 ER OIL	Warm Mix Tech	Commercial 64-28 Oil	QPL 64-28 ER Oil	Commercial 70-28 Oil	QPL 70-28 ER OIL	Warm Mix Tech				
ITB 6098-25 ASPHALTIC MIXES	Perry Plant					Sullivan Plant					Shamrock Manufacturing Plant 1					Shamrock Manufacturing Plant 2					Grove Pt / Plant								
<b>Due to the volatility of this product, vendors will be allowed to provide updated pricing on the first of each</b>																													
ASPHALTIC MIXES	\$76.00	Do Not Carry	Do Not Carry	Do Not Carry	*	\$74.00	Do Not Carry	Do Not Carry	Do Not Carry	*	\$76.00	\$79.00	\$79.00	\$79.00	n/a	\$68.00	\$71.00	\$71.00	\$71.00	n/a	\$67.00	\$67.00	\$67.00	\$67.00	n/a				
HMA Class 1/2 Inch	\$79.00	Do Not Carry	Do Not Carry	Do Not Carry	*	\$77.00	Do Not Carry	Do Not Carry	Do Not Carry	*	\$79.00	\$82.00	\$82.00	\$82.00	n/a	\$71.00	\$74.00	\$74.00	\$74.00	n/a	\$70.00	\$70.00	\$70.00	\$70.00	n/a				
HMA Class 3/4 Inch	*No Additional Charge Call Ahead To Order					*No Additional Charge Call Ahead To Order					Virgin Mix (No Rap)	Virgin Mix (No Rap)	Virgin Mix (No Rap)			20% RAP	20% RAP	20% RAP	20% RAP	n/a									
Delivery Fees	\$ -					\$ -					\$ -					\$ -													
Other Fees	Sales Tax					Sales Tax					Sales Tax					Sales Tax													
<b>CALL 24 HOURS IN ADVANCE FOR ALL ORDERS</b>					<b>CALL 24 HOURS IN ADVANCE FOR ALL ORDERS</b>					<b>All Items - Virgin Mix - (no Rap)</b>					<b>All Items - 20% Rap</b>					<b>CALL 24 HOURS IN ADVANCE FOR ALL ORDERS</b>									
Facility:	Perry Plant #3 13302 N Perry, Spokane WA					Facility:	Sullivan Plant 1902 N Sullivan Rd., Spokane WA					Facility:	Shamrock Manufacturing Plant 1 110 N Hayford Rd., Spokane WA					Facility:	Shamrock Manufacturing Plant 2 12605 N Hayford Rd., Spokane WA					Facility:	Grove Pt / Plant 7909 S. Grove Rd Spokane WA				
7:00 am - 5:00 pm (Monday - Friday)					7:00 am - 5:00 pm (Monday - Friday)					7:00 am - 3:30 pm (Monday - Friday)					7:00 am - 3:30 pm (Monday - Friday)					7:00 am - 5:00 pm (Monday - Friday)									
Operating Hours Phone 509 979 7640					Operating Hours Phone 509 979 7640					Operating Hours Phone 509 244 2800					Operating Hours Phone 509 244 2800					Operating Hours Phone 509 244 8908									
After Hours Phone 509 979 7640					After Hours Phone 509 979 7640					After Hours Phone 509 244 2800					After Hours Phone 509 244 2800					After Hours Phone 509 780 2445									

**Agenda Sheet for City Council:****Committee:** PIES **Date:** 05/20/2024**Committee Agenda type:** Consent**Date Rec'd**

5/20/2024

**Clerk's File #**

OPR 2024-0456

**Cross Ref #**

OPR 2024-0454

**Cross Ref #**

OPR 2024-0455

**Council Meeting Date:** 06/10/2024**Submitting Dept**

STREETS

**Bid #**

ITB 6098-24

**Contact Name/Phone**

CLINT HARRIS 625-7744

**Requisition #**

VB

**Contact E-Mail**

CEHARRIS@SPOKANECITY.ORG

**Agenda Item Type**

Purchase w/o Contract

**Council Sponsor(s)**

BWILKERSON JBINGLE KKLITZKE

**Agenda Item Name**

1100 - ASPHALTIC MIXES

**Agenda Wording**

The Street Department is seeking approval for the purchase of asphaltic mixes at a cost not to exceed \$1,925,000.00 annually.

**Summary (Background)**

This contract, awarded via bid (ITB 6098-24) to Shamrock Paving, Inc. (Spokane)(OPR 2024-0454), Inland Asphalt Company (Spokane)(OPR 2024-0455), and Poe Asphalt Paving, Inc. (Spokane)(OPR 2024-0456) will begin June 2nd, 2024 and expire June 1st, 2029. This contract will be used by Streets, Sewer, Parks, and Water Depts.

Lease? NO

Grant related? NO

Public Works? NO

**Fiscal Impact**

Approved in Current Year Budget? YES

Total Cost

\$ 9,625,000.00

Current Year Cost

\$ 1,925,000.00

Subsequent Year(s) Cost

\$ 1,925,000.00/year for 2025-2029

**Narrative****Amount****Budget Account**

Expense

\$ 1,925,000.00

# Various

Select

\$

#

Select

\$

#

Select

\$

#

\$

#

\$

#



**Continuation of Wording, Summary, Approvals, and Distribution**

**Agenda Wording**

**Summary (Background)**

**Approvals**

<b><u>Dept Head</u></b>	HARRIS, CLINT E.
<b><u>Division Director</u></b>	FEIST, MARLENE
<b><u>Accounting Manager</u></b>	ORLOB, KIMBERLY
<b><u>Legal</u></b>	HARRINGTON,
<b><u>For the Mayor</u></b>	PICCOLO, MIKE

**Additional Approvals**

<b><u>PURCHASING</u></b>	PRINCE, THEA

**Distribution List**

Jared Boucher, jared.boucher@inlandnw.com	Chuck Green, chuckg@shamrockpaving.us
Derek Helt, derek@poeasphalt.com	ceharris@spokanecity.org
jwthomas@spokanecity.org	jklapp@spokanecity.org
jdykes@spokanecity.org	rrinderle@spokanecity.org
streetaccounting@spokanecity.org	tprince@spokanecity.org

## Committee Agenda Sheet

### Public Infrastructure, Environment & Sustainability Committee

<b>Committee Date</b>	05/20/2024
<b>Submitting Department</b>	Streets
<b>Contact Name</b>	Clint Harris
<b>Contact Email &amp; Phone</b>	<a href="mailto:ceharris@spokanecity.org">ceharris@spokanecity.org</a> , 509-625-7744
<b>Council Sponsor(s)</b>	<u>Wilkerson, Bingle, Klitzke</u>
<b>Select Agenda Item Type</b>	<input checked="" type="checkbox"/> Consent <input type="checkbox"/> Discussion    Time Requested:
<b>Agenda Item Name</b>	1100 –Asphaltic Mixes
<b>Proposed Council Action</b>	<input checked="" type="checkbox"/> Approval to proceed to Legislative Agenda <input type="checkbox"/> Information Only
<b>Summary (Background)</b>  *use the Fiscal Impact box below for relevant financial information	The Street Department is seeking approval for the purchase of asphaltic mixes at a cost not to exceed \$1,925,000.00 annually. This contract, awarded via bid (ITB 6098-24) to Shamrock Paving, Inland Asphalt, and Poe Asphalt Paving Inc. will begin June 2 <sup>nd</sup> , 2024 and expire June 1 <sup>st</sup> , 2029.  This contract will be used by Streets, Sewer, Parks, and Water Depts.
<b>Fiscal Impact</b>	\$1,925,000.00
<b>Approved in current year budget?</b>	<input checked="" type="checkbox"/> Yes <input type="checkbox"/> No <input type="checkbox"/> N/A
Total Cost:	<u>1,925,000.00</u>
Current year cost:	\$1,925,000.00
Subsequent year(s) cost:	1,925,000.00/year for each extension year
<b>Narrative:</b>	Please provide financial due diligence review, as applicable, such as number and type of positions, grant match requirements, summary type details (personnel, maintenance and supplies, capital, revenue), impact on rates, fees, or future shared revenue
<b>Funding Source</b>	<input type="checkbox"/> One-time <input checked="" type="checkbox"/> Recurring <input type="checkbox"/> N/A
Specify funding source:	Program revenue
Is this funding source sustainable for future years, months, etc?	Yes
<b>Expense Occurrence</b>	<input type="checkbox"/> One-time <input checked="" type="checkbox"/> Recurring <input type="checkbox"/> N/A
Other budget impacts:	(revenue generating, match requirements, etc.)
<b>Operations Impacts</b> (If N/A, please give a brief description as to why)	
What impacts would the proposal have on historically excluded communities? N/A	<u>Asphalt is a product used to maintain roadways across the City</u>
How will data be collected, analyzed, and reported concerning the effect of the program/policy by racial, ethnic, gender identity, national origin, income level, disability, sexual orientation, or other existing disparities? N/A	<u>Asphalt is a product used to maintain roadways across the City</u>
How will data be collected regarding the effectiveness of this program, policy or product to ensure it is the right solution? N/A	<u>Asphalt is a product used to maintain roadways across the City</u>

Describe how this proposal aligns with current City Policies, including the Comprehensive Plan, Sustainability Action Plan, Capital Improvement Program, Neighborhood Master Plans, Council Resolutions, and others? N/A  
Asphalt is a product used to maintain roadways across the City

ITEM / DESCRIPTION	INLAND ASPHALT					INLAND ASPHALT					SHAMROCK MANUFACTURING 110 N HAYFORD RD SPOKANE WA 99224					SHAMROCK MANUFACTURING 110 N HAYFORD RD SPOKANE WA 99224					POE ASPHALT PAVING INC 7090 S Grove Spokane WA 99224								
	Commercial 64-28 Oil	QPL 64-28 ER Oil	Commercial 70-28 Oil	QPL 70-28 ER OIL	Warm Mix Tech*	Commercial 64-28 Oil	QPL 64-28 ER Oil	Commercial 70-28 Oil	QPL 70-28 ER OIL	Warm Mix Tech*	Commercial 64-28 Oil	QPL 64-28 ER OIL	Commercial 70-28 Oil	QPL 70-28 ER Oil	Warm Mix Tech	Commercial 64-28 Oil	QPL 64-28 ER OIL	Commercial 70-28 Oil	QPL 70-28 ER Oil	Warm Mix Tech	Commercial 64-28 Oil	QPL 64-28 ER Oil	Commercial 70-28 Oil	QPL 70-28 ER OIL	Warm Mix Tech				
ITB 6098-25 ASPHALTIC MIXES	Perry Plant					Sullivan Plant					Shamrock Manufacturing Plant 1					Shamrock Manufacturing Plant 2					Grove Pt / Plant								
<b>Due to the volatility of this product, vendors will be allowed to provide updated pricing on the first of each</b>																													
ASPHALTIC MIXES	\$76.00	Do Not Carry	Do Not Carry	Do Not Carry	*	\$74.00	Do Not Carry	Do Not Carry	Do Not Carry	*	\$76.00	\$79.00	\$79.00	\$79.00	n/a	\$68.00	\$71.00	\$71.00	\$71.00	n/a	\$67.00	\$67.00	\$67.00	\$67.00	n/a				
HMA Class 1/2 Inch	\$79.00	Do Not Carry	Do Not Carry	Do Not Carry	*	\$77.00	Do Not Carry	Do Not Carry	Do Not Carry	*	\$79.00	\$82.00	\$82.00	\$82.00	n/a	\$71.00	\$74.00	\$74.00	\$74.00	n/a	\$70.00	\$70.00	\$70.00	\$70.00	n/a				
HMA Class 3/4 Inch	*No Additional Charge Call Ahead To Order					*No Additional Charge Call Ahead To Order					Virgin Mix (No Rap)	Virgin Mix (No Rap)	Virgin Mix (No Rap)			20% RAP	20% RAP	20% RAP	20% RAP	n/a									
Delivery Fees	\$ -					\$ -					\$ -					\$ -													
Other Fees	Sales Tax					Sales Tax					Sales Tax					Sales Tax													
<b>CALL 24 HOURS IN ADVANCE FOR ALL ORDERS</b>					<b>CALL 24 HOURS IN ADVANCE FOR ALL ORDERS</b>					<b>All Items - Virgin Mix - (no Rap)</b>					<b>All Items - 20% Rap</b>					<b>CALL 24 HOURS IN ADVANCE FOR ALL ORDERS</b>									
Facility:	Perry Plant #3 13302 N Perry, Spokane WA					Facility:	Sullivan Plant 1902 N Sullivan Rd., Spokane WA					Facility:	Shamrock Manufacturing Plant 1 110 N Hayford Rd., Spokane WA					Facility:	Shamrock Manufacturing Plant 2 12605 N Hayford Rd., Spokane WA					Facility:	Grove Pt / Plant 7909 S. Grove Rd Spokane WA				
7:00 am - 5:00 pm (Monday - Friday)					7:00 am - 5:00 pm (Monday - Friday)					7:00 am - 3:30 pm (Monday - Friday)					7:00 am - 3:30 pm (Monday - Friday)					7:00 am - 5:00 pm (Monday - Friday)									
Operating Hours Phone 509 979 7640					Operating Hours Phone 509 979 7640					Operating Hours Phone 509 244 2800					Operating Hours Phone 509 244 2800					Operating Hours Phone 509 244 8908									
After Hours Phone 509 979 7640					After Hours Phone 509 979 7640					After Hours Phone 509 244 2800					After Hours Phone 509 244 2800					After Hours Phone 509 780 2445									

**Agenda Sheet for City Council:****Committee:** PIES **Date:** 05/20/2024**Committee Agenda type:** Consent**Date Rec'd**

5/20/2024

**Clerk's File #**

OPR 2021-0301

**Cross Ref #****Project #****Council Meeting Date:** 06/10/2024**Submitting Dept**

SOLID WASTE DISPOSAL

**Bid #**

ITB 5383-21

**Contact Name/Phone**

DAVID PAINE 625-6878

**Requisition #**

VB 301248

**Contact E-Mail**

DPAINE@SPOKANECITY.ORG

**Agenda Item Type**

Purchase w/o Contract

**Council Sponsor(s)**

BWILKERSON JBINGLE KKLITZKE

**Agenda Item Name**

4490 VALUE BLANKET RENEWAL FOR FEEDER AND GRATE PARTS

**Agenda Wording**

Value blanket renewal 2 of 3 with Hitachi Zosen Inova U.S.A. LLC (Norcross, GA), for the purchase of feeder and grate parts at the Waste to Energy Facility from 7/1/2024-6/30/2024 and a total cost not to exceed \$1,300,000.00 plus tax.

**Summary (Background)**

The Waste to Energy Facility operates 24/7 incinerating municipal solid waste. The feeder and grate parts of the incinerator require frequent maintenance and replacement in order to maintain constant operation. On Apr. 5, 2021 bidding closed on ITB 5383-21 for the as-needed annual requirement of these parts and Hitachi Zosen was the only respondent. The initial value blanket award was for two (2) years with the option of three (3) additional one-year renewals. This will be the second renewal.

Lease? NO

Grant related? NO

Public Works? NO

**Fiscal Impact**

Approved in Current Year Budget? YES

Total Cost \$ 1,300,000.00

Current Year Cost \$ 1,300,000.00

Subsequent Year(s) Cost \$

**Narrative**

This is an annual repair and maintenance supply expense that was planned for in the 2024 Solid Waste Disposal budget.

**Amount****Budget Account**

Expense \$ 1,300,000.00

# 4490-44100-37148-53210-34002

Select \$

#

Select \$

#

Select \$

#

\$

#

\$

#



**Continuation of Wording, Summary, Approvals, and Distribution**

**Agenda Wording**

**Summary (Background)**

**Approvals**

<b><u>Dept Head</u></b>	PAINE, DAVID
<b><u>Division Director</u></b>	FEIST, MARLENE
<b><u>Accounting Manager</u></b>	ALBIN-MOORE, ANGELA
<b><u>Legal</u></b>	HARRINGTON,
<b><u>For the Mayor</u></b>	PICCOLO, MIKE

**Additional Approvals**

<b><u>PURCHASING</u></b>	PRINCE, THEA

**Distribution List**

	mdorgan@spokanecity.org
jsalstrom@spokanecity.org	tprince@spokanecity.org
rrinderle@spokanecity.org	



## Committee Agenda Sheet

### Public Infrastructure, Environment & Sustainability Committee

<b>Submitting Department</b>	Solid Waste Disposal
<b>Contact Name</b>	David Paine
<b>Contact Email &amp; Phone</b>	<a href="mailto:dpaine@spokanecity.org">dpaine@spokanecity.org</a> , 509-625-6878
<b>Council Sponsor(s)</b>	CM's Kinnear and Bingle
<b>Select Agenda Item Type</b>	<input checked="" type="checkbox"/> Consent <input type="checkbox"/> Discussion    Time Requested:
<b>Agenda Item Name</b>	Value blanket renewal for the purchase of feeder and grate parts for the Waste to Energy Facility
<b>Summary (Background)</b>  *use the Fiscal Impact box below for relevant financial information	<p>The Waste to Energy Facility operates 24/7 incinerating municipal solid waste. The feeder and grate parts of the incinerator require frequent maintenance and replacement to maintain constant operation. They are specialized parts and have very long lead times. To ensure that parts are available on site when needed, they need to be ordered in various quantities depending on need, and well in advance of scheduled maintenance outages.</p> <p>On April 5, 2021 bidding closed on ITB 5383-21 for the as-needed annual requirement of feeder and grate parts for the Waste to Energy Facility. Hitachi Zosen Inova U.S.A. LLC, of Norcross, Georgia was the only respondent. The initial value blanket award was for two years, spanning from July 1, 2021 through June 30, 2023 for a total cost of \$600,000.00 plus tax, with the option of three additional one-year renewals. This will be the first renewal spanning from July 1, 2023 through June 30, 2024 with a total cost not to exceed \$1,200,000.00 plus tax. The additional amount is due to excessively long lead times which requires that orders are placed a year in advance.</p>
<b>Proposed Council Action</b>	Council approval of value blanket renewal
<b>Fiscal Impact</b>	<p>Total Cost: <u>\$1,200,000.00 plus tax</u></p> <p>Approved in current year budget?    <input checked="" type="checkbox"/> Yes    <input type="checkbox"/> No    <input type="checkbox"/> N/A</p> <p>Funding Source    <input type="checkbox"/> One-time    <input checked="" type="checkbox"/> Recurring Specify funding source: <a href="#">Click or tap here to enter text.</a></p> <p>Expense Occurrence    <input type="checkbox"/> One-time    <input checked="" type="checkbox"/> Recurring</p> <p>Other budget impacts: (revenue generating, match requirements, etc.)</p>
<b>Operations Impacts (If N/A, please give a brief description as to why)</b>	<p>What impacts would the proposal have on historically excluded communities?</p> <p>This work is necessary to maintain the WTE Facility's ability to generate low-cost power supplied to the grid. Low-cost power is imperative to curbing the rise in cost of electricity.</p>

How will data be collected, analyzed, and reported concerning the effect of the program/policy by racial, ethnic, gender identity, national origin, income level, disability, sexual orientation, or other existing disparities?

The contractor is governed by WA L&I.

How will data be collected regarding the effectiveness of this program, policy or product to ensure it is the right solution?

The COS Procurement Policies regulate and safeguard this process.

Describe how this proposal aligns with current City Policies, including the Comprehensive Plan, Sustainability Action Plan, Capital Improvement Program, Neighborhood Master Plans, Council Resolutions, and others?

This work supports the continued safe operation the Facility. The expenditure is supportive of the Sustainable Action Plan and the Capital Improvement Program.



CITY OF SPOKANE  
 CITY OF SPOKANE - WTEF  
 2900 S GEIGER BLVD  
 SPOKANE, WA 99224-5400  
 PHONE 509 625 6527

2-Year Base Period	1st Option Period	2nd Option Period
--------------------	-------------------	-------------------

<b>VB-301248 Feeder Grate Parts - As Needed Annual Requirement</b>	<b>Valid Through 6/30/2023</b>	<b>Valid 7/1/2023 Through 6/30/2024</b>	<b>Valid 7/1/2024 Through 6/30/2025</b>
--	--------------------------------	---	---

Item	Unit Price Includes Freight Cost per ITB 5383-20	Unit Price Includes Freight Cost per ITB 5383-21	Unit Price Includes Freight Cost per ITB 5383-21
1278 (01150ME164) Nut, Cap, 5/8"-11 304SS	\$6.50	\$6.50	\$4.80
1316 (01150ME181) Angle Mounting, 1" 309SS	\$47.10	\$47.10	\$14.59
1317 (01150ME160) Angle Mounting, 2" 309SS	\$78.17	\$78.17	\$17.02
1318 (01150ME163) Stud, Weld, Header Protection	\$3.75	\$3.75	\$5.96
1907 (01159ME050) Kit, Mounting, Grate Thermocouple	\$150.00	\$150.00	\$182.33
1003114 (01159ME600) Roller Assembly, Vivax	\$728.98	\$728.98	\$713.50
0320051 (01159ME148) Plate, Header Protection	\$143.00	\$168.60	\$217.57
0320307 (01159ME473) Holding Device, Roof Element (w/rubs)	\$139.60	\$139.60	\$121.81
0320403 (01159ME122) Roof Element Middle	\$103.50	\$123.75	\$148.29
0320405 (01159ME114) Roof Element LH	\$80.00	\$85.68	\$102.10
0320406 (01159ME118) Roof Element RH	\$80.00	\$85.68	\$102.10
32B0013 (01156ME146) Plate, Front Ram feeder Middle Bottom	\$92.50	\$92.50	\$102.10
32B0014 (01156ME142) Plate, Front Ram feeder Bottom	\$121.00	\$121.00	\$133.71
32B1545 (01156ME100) Plate, Discharge, Ram feeder drop-off	\$295.00	\$295.00	\$325.75
32B1560 Butting Ring, Grate Carriage Roller	\$33.00	\$33.00	\$36.47
32B1561 (01159ME238) Spacer, Grate Carriage Roller	\$30.24	\$30.24	\$20.66
32B1562 (01159ME216) Wear Plate	\$71.50	\$71.50	\$79.01
32B1563 (01159ME461) Distance Plate 7.8"	\$12.50	\$12.50	\$18.59
32B1600 Roller, Grate (Wheel Only)	\$554.00	\$554.00	\$114.26
32B1658 (01159ME212) Wear Plate	\$126.50	\$126.50	\$170.17
32B1659 (01159ME214) Wear Plate	\$64.00	\$64.00	\$76.58
32B1660 (01159ME458) Distance Plate 4.3"	\$14.50	\$14.50	\$16.04
32B1661 (01159ME460) Distance Plate 4.9"	\$16.00	\$16.00	\$17.62
32B1663 (01159ME482) Axel Guard	\$14.50	\$14.50	\$18.23
32B1664 (01159ME422) Spacer	\$17.50	\$17.50	\$58.34
32B1690 (01159ME246) Nut, Swivel, Tension Ro	\$32.90	\$32.90	\$29.52
32C0002 (01156ME102) Plate, Discharge, Ramform upper drop-off	\$354.00	\$354.00	\$391.39
32C0008 (01156ME122) Plate, Corner Cover	\$291.50	\$291.50	\$322.11
32C0009 (01156ME126) Plate, Corner Cover	\$204.50	\$204.50	\$226.08
32C0010 (01156ME136) Plate, Front Ram feeder	\$202.50	\$202.50	\$223.65
32C0011 (01156ME132) Corner Piece, Ram feed Front	\$208.00	\$208.00	\$228.51
32C1670 (01156ME110) Roof Element, LH Ram Sidewall	\$186.00	\$186.00	\$205.42
32C1671 (01156ME108) Roof Element, Ram Sidewall	\$134.70	\$134.70	\$148.29
32C1674 (01156ME112) Roof Element, RH Ram Sidewall	\$186.00	\$186.00	\$205.42
32D0011 (01156ME270) Base Plate, middle Ram	\$551.00	\$612.00	\$729.30
32D0054 (01159ME585) Thermocouple Block (w/out thermocouple)	\$299.00	\$299.00	\$498.36
32D1587 (01159ME204) Carriage Machining, LH	\$4,834.50	\$4,834.50	\$6,391.10
32D1584 (01159ME206) Carriage Machining, RH	\$4,834.50	\$4,834.50	\$6,391.10
32D1637 (01159ME210) Wedge	\$365.43	\$365.43	\$369.51
32L0012 (01156ME276) Base Plate, LH Ram	\$1,084.60	\$1,631.00	\$2,332.54
32R0012 (01156ME280) Base Plate, RH Ram	\$1,084.60	\$1,631.00	\$2,332.54
BC18192 (01159ME440) Block Holding Tube - Fixed Row	\$594.00	\$658.80	\$945.66
BC18202 (01159ME450) Block Holding Tube - Movable Row	\$594.00	\$658.80	\$945.66
BD16202 (01159ME426) Beam, Transverse	\$1,210.00	\$1,342.35	\$1,599.60
LU18182 (01159ME337) Tension Rod, LH	\$90.00	\$90.00	\$170.46
M032408 (01159ME105) Grate Block, Side	\$166.00	\$205.00	\$244.32
M032409 (01159ME109) Press Plate, RH	\$233.00	\$256.00	\$305.09
M032410 (01159ME107) Press Plate, LH	\$233.00	\$256.00	\$305.09
M032420 (01159ME103) Grate Block, Small (European Design)	\$116.00	\$138.75	\$165.31
RU18182 (01159ME353) Tension Rod, RH	\$90.00	\$90.00	\$170.46
Bearing, Each, Grate Carriage Roller	\$190.00	\$190.00	\$210.28
V621753 (01159ME222) Jam Nut, Rod End M45x1.5	\$25.14	\$25.14	\$21.88
Ring Lamella, Grate Carriage Roller (3 per set)	\$33.00	\$33.00	\$47.40
Roller Bearing BMR 35/68 x 40/45	\$190.00	\$190.00	\$210.93

<small>Percentage Markup Above Vendor's Cost: Vendor to provide Percentage Markup Above Vendor's Cost, should Vendor not provide discount percentage off list, for any other additional Feeder and Grate Parts, or related items, not listed on "ITB 5383-21 Pricing Page", but may be realized are needed at a later point in time. The markup percentage would remain unchanged throughout the life of the contract and any renewals. Enter Percentage Markup Above Vendor's Cost.</small>	20%	20%	20% plus costs for transport, etc.
--	-----	-----	------------------------------------

Hitachi	2-yr Base Period Per Hitachi Response To ITB 5383-21	NAME	John Curtis McBurney, Sr
Mr. John Curtis McBurney, Sr. john.mcburney@hz-inova.com		SIGNATURE	<i>[Signature]</i>
Mob: 1 404 408 4076		DATE	April 26, 2024

**Agenda Sheet for City Council:****Committee:** PIES **Date:** 05/20/2024**Committee Agenda type:** Consent**Date Rec'd**

5/20/2024

**Clerk's File #**

OPR 2024-0457

**Cross Ref #****Project #****Council Meeting Date:** 06/10/2024**Submitting Dept**

SOLID WASTE DISPOSAL

**Bid #**

ITB 6079-24

**Contact Name/Phone**

DAVID PAINE 625-6878

**Requisition #**

RN 272

**Contact E-Mail**

DPAINE@SPOKANECITY.ORG

**Agenda Item Type**

Purchase w/o Contract

**Council Sponsor(s)**

BWILKERSON JBINGLE KKLITZKE

**Agenda Item Name**

4490 VALUE BLANKET FOR VALVES AND REPAIR KITS

**Agenda Wording**

Five year value blanket award to Fluid Controls and Components, Inc. (Richland, WA) for the as-needed purchase of valves and repair kits for the Waste to Energy Facility from 6/10/24-6/9/29 and an annual cost of \$300,000.00 plus tax (\$1.5M total).

**Summary (Background)**

The Waste to Energy Facility utilizes a variety of valve styles, configurations, types and sizes throughout. To be able to respond quickly when a repair or replacement of a valve is required, parts need to be readily available. On April 8, 2024, bidding closed on ITB 6079-24 for the as-needed purchase of these valves and repair kits. The only response received was from Fluid Controls and Components, Inc. (Richland, WA). The value blanket award would be for five (5) years.

Lease? NO

Grant related? NO

Public Works? NO

**Fiscal Impact**

Approved in Current Year Budget? YES

Total Cost \$ 1,500,000.00

Current Year Cost \$ 300,000.00

Subsequent Year(s) Cost \$ 300,000.00

**Narrative**

This is an annual repair and maintenance supply expense that was planned for in the 2024 Solid Waste Disposal budget.

**Amount****Budget Account**

Expense \$ 1,500,000.00 (2024-2029)

# 4490-44100-37148-53210-34002

Select \$

#

Select \$

#

Select \$

#

\$

#

\$

#



**Continuation of Wording, Summary, Approvals, and Distribution**

**Agenda Wording**

**Summary (Background)**

**Approvals**

<b><u>Dept Head</u></b>	PAINE, DAVID
<b><u>Division Director</u></b>	FEIST, MARLENE
<b><u>Accounting Manager</u></b>	ALBIN-MOORE, ANGELA
<b><u>Legal</u></b>	HARRINGTON,
<b><u>For the Mayor</u></b>	PICCOLO, MIKE

**Additional Approvals**

<b><u>PURCHASING</u></b>	PRINCE, THEA

**Distribution List**

	mdorgan@spokanecity.org
jsalstrom@spokanecity.org	tprince@spokanecity.org
rrinderle@spokanecity.org	

## Committee Agenda Sheet

### Public Infrastructure, Environment & Sustainability Committee

<b>Committee Date</b>	May 20, 2024
<b>Submitting Department</b>	Solid Waste Disposal
<b>Contact Name</b>	David Paine
<b>Contact Email &amp; Phone</b>	<a href="mailto:dpaine@spokanecity.org">dpaine@spokanecity.org</a> , 509-625-6878
<b>Council Sponsor(s)</b>	Wilkerson, Bingle, Klitzke
<b>Select Agenda Item Type</b>	<input checked="" type="checkbox"/> Consent <input type="checkbox"/> Discussion    Time Requested:
<b>Agenda Item Name</b>	Value blanket for the as-needed purchase of valves and repair kits at the Waste to Energy Facility.
<b>Proposed Council Action</b>	<input checked="" type="checkbox"/> Approval to proceed to Legislative Agenda <input type="checkbox"/> Information Only
<b>Summary (Background)</b>  *use the Fiscal Impact box below for relevant financial information	<p>The Waste to Energy Facility utilizes a variety of valve styles, configurations, types and sizes throughout. As they age and wear, they need to be replaced. To be able to respond quickly when a repair or replacement of a valve is required, parts need to be readily available.</p> <p>On April 8, 2024, bidding closed on ITB 6079-24 for the as-needed purchase of valves and repair kits for the Waste to Energy Facility. The only response received was from Fluid Controls and Components, Inc. (Richland, WA), who is able to supply most of the required valves for the facility. The value blanket award would be for five (5) years with an estimated annual spend of \$300,000.00 plus tax. The metals/materials required to manufacture valves are very volatile and pricing adjustments will be considered every thirty days with vendor pricing support.</p>
<p><b>Fiscal Impact</b></p> <p><b>Approved in current year budget?</b>    <input type="checkbox"/> Yes    <input type="checkbox"/> No    <input type="checkbox"/> N/A</p> <p>Total Cost: <u>\$1.5M (\$300,000.00 plus tax for five years)</u></p> <p>    Current year cost: \$300,000.00</p> <p>    Subsequent year(s) cost: \$300,000.00</p> <p><b>Narrative:</b> <u>This is an annual repair and maintenance supply expense that was planned for in the 2024 Solid Waste Disposal budget.</u></p> <p><b>Funding Source</b>    <input type="checkbox"/> One-time    <input checked="" type="checkbox"/> Recurring    <input type="checkbox"/> N/A</p> <p>Specify funding source: Program revenue</p> <p>Is this funding source sustainable for future years, months, etc? Yes</p> <p><b>Expense Occurrence</b>    <input type="checkbox"/> One-time    <input checked="" type="checkbox"/> Recurring    <input type="checkbox"/> N/A</p> <p>Other budget impacts: (revenue generating, match requirements, etc.)</p>	
<p><b>Operations Impacts (If N/A, please give a brief description as to why)</b></p> <ul style="list-style-type: none"> <li>What impacts would the proposal have on historically excluded communities? Public works services and projects are designed to serve all citizens and businesses. We strive to offer a consistent level of service to all, to distribute public investment throughout the community and to respond to gaps in services identified in various City plans.</li> </ul>	

- How will data be collected, analyzed, and reported concerning the effect of the program/policy by racial, ethnic, gender identity, national origin, income level, disability, sexual orientation, or other existing disparities?  
N/A
- How will data be collected regarding the effectiveness of this program, policy, or product to ensure it is the right solution?  
Public Works follows the City's established procurement and public works bidding regulations and policies to bring items forward, and then uses contract management best practices to ensure desired outcomes and regulatory compliance.
- Describe how this proposal aligns with current City Policies, including the Comprehensive Plan, Sustainability Action Plan, Capital Improvement Program, Neighborhood Master Plans, Council Resolutions, and others?  
This work is consistent with annual budget strategies to limit costs and approved projects in the 6-year CIP.

**Council Subcommittee Review**

- Please provide a summary of council subcommittee review. If not reviewed by a council subcommittee, please explain why not.

Not applicable

## Rinderle, Rick

---

**From:** Patty Maher <pmaher@dupillgroup.com>  
**Sent:** Tuesday, April 23, 2024 1:12 PM  
**To:** Rinderle, Rick  
**Cc:** Newberg, Foster; Pratt, Larry; Dorgan, Michelle  
**Subject:** RE: Documented Response Requested ITB 6079-24 Valves and Repair Kits As-Needed (City of Spokane)

[CAUTION - EXTERNAL EMAIL - Verify Sender]

Hi Rick,

Thank you for contacting me today. As we discussed the metals/materials that it takes to manufacture valves is very volatile, FCCI can hold pricing for 30 days and we can also support and substantiate with supplier quotes. We agree with your statements below.

Best regards,

### Patty Maher

Account Administrative Assistant

### Fluid Controls and Components, Inc.,

a division of Dupill Group Companies  
T (509) 375-0774 x 2000 | F (509) 375-0679  
[pmaher@dupillgroup.com](mailto:pmaher@dupillgroup.com)



[www.DupillGroup.com](http://www.DupillGroup.com) | [LinkedIn](#) | [YouTube](#)



CONFIDENTIALITY WARNING: This email may contain confidential or proprietary business information and is for the sole use of the intended recipient(s). Any unauthorized use or disclosure of this communication, including attachments, is strictly prohibited. If you believe that you have received this email in error, please notify the sender immediately and delete it from your system



---

**From:** Rinderle, Rick [mailto:rrinderle@spokanecity.org]  
**Sent:** Tuesday, April 23, 2024 11:56 AM  
**To:** Patty Maher <pmaher@dupillgroup.com>  
**Cc:** Rinderle, Rick <rrinderle@spokanecity.org>; Newberg, Foster <fnewberg@spokanecity.org>; Pratt, Larry <lpratt@spokanecity.org>; Dorgan, Michelle <mdorgan@spokanecity.org>  
**Subject:** Documented Response Requested ITB 6079-24 Valves and Repair Kits As-Needed (City of Spokane)  
**Importance:** High

**CAUTION:** This email originated from outside the organization. Do not click links or open attachments unless you recognize the sender and know the content is safe.

**Fluid Controls and Components, Inc.**

Hello Ms. Patty Maher,  
Phone 509 375 0744  
[pmaher@dupillgroup.com](mailto:pmaher@dupillgroup.com)

Hello Patty,

Recapping our phone call today, 4/23/2024, pertaining to Fluid Control and Components attached response to ITB 6079-24, Valves and Repair Kits As Needed...

Regarding below depicted response to Pricing #3.1, to which Fluid Control and Components advised "I don't agree, and I don't acknowledge" holding pricing for a 6-month period...

Patty, you advised during the phone call that valves are a volatile commodity, and Fluid Control and Components is encountering price changes ranging from 2 days to 2 weeks; however, you stated that Fluid Control and Components will hold its bid pricing for a 30-days, from the bid due date of 4/8/2024; and continue to review pricing on a 30-day increments. Any order that would be placed after a 30-day increment passes the City would need to obtain current pricing and lead time, to which Fluid Control and Components would provide current pricing "and" support to substantiate the current pricing, as reference in Pricing #3.3, as depicted below.

Patty, you are kindly asked to response to this email, providing a documented response that would be incorporated with Fluid Control and Components response to ITB 6079-24, that Fluid Control and Components will adhere to what has been stated above through-out a five-year value blanket.

PRICING
---------

#3.1	PRICING - FIRM FIXED PRICE. Pricing submitted on "Pricing Page" must be a firm fixed price for a 6-month period from the bid due date. Pricing adjustment request will be considered six-months from the bid due date, and then on the annual anniversary of the award, and then every six-months from anniversary of award, with vendor providing justification.	I don't agree and I don't acknowledge
#3.2	All price adjustments must be agreed on by both parties. Vendor must request pricing adjustment in writing, and cannot be applied retroactively to orders already placed with the Vendor. Price increases must apply to all or broad classes of customers and shall in no way single out the Purchaser.	I agree and I acknowledge

#3.3	Back up documentation from manufacturer and/or other sources must be included to justify request. The United States published indices such as the Producer Price Index (PPI), or other government data, may be referenced to help substantiate the Vendor's documentation.	I agree and I acknowledge
#3.4	Adjustments to pricing shall be to not produce a higher profit margin.	I agree and I acknowledge
#3.5	The City of Spokane reserves the right to cancel the contract if the escalation of price is not advantageous to the City.	I agree and I acknowledge
#4	PRICE DECREASES: During the contract period, any price decreases obtained by Contractor shall be reflected in a contract price reduction to the Purchaser retroactive to the Contractor's effective date	I agree and I acknowledge

Respectfully, document response soonest.

**RICK RINDERLE** | CITY OF SPOKANE | PURCHASING SPECIALIST  
 PHONE 509 625 6527 | [rrinderle@spokanecity.org](mailto:rrinderle@spokanecity.org) | [spokanecity.org](http://spokanecity.org)

*Emails and attachments sent to or from the City, including personal information, are presumptively public records that are subject to disclosure. – Chapter 42.56 RCW*

**Bid Response Summary**

**Bid Number** ITB 6079-24  
**Bid Title** Valves and Repair Kits As-Needed  
**Due Date** Monday, April 8, 2024 1:00:00 PM [(UTC-08:00) Pacific Time (US & Canada)]  
**Bid Status** Closed to Bidding  
**Company** Fluid Controls and Components, Inc.  
**Submitted By** Adrienne Eldridge - Monday, April 8, 2024 11:05:51 AM [(UTC-08:00) Pacific Time (US & Canada)]  
 adrienne@dupillgroup.com 509-375-0774

**Comments****Question Responses**

Group	Reference Number	Question	Response
ADDENDA			
	#1	ADDENDA Bidder acknowledges receipt of _____ addenda and agrees that their requirements have been included in this bid proposal. If none were issued enter "0".	2
BID SUBMISSION			
	#1.	Bid Responses shall be submitted electronically through the City of Spokane's bidding portal: <a href="https://spokane.procureware.com">https://spokane.procureware.com</a> on or before the Due Date and time mentioned above. Hard, e-mailed or faxed copies and/or late bids shall not be accepted.	I agree and I acknowledge
	#2.	The City of Spokane is not responsible for bids electronically submitted late. It is the responsibility of the Bidder to be sure the bids are electronically submitted sufficiently ahead of time to be received no later than 1:00 p.m. Pacific Local Time, on the bid opening date.	I agree and I acknowledge
	#3	All communication between the Bidder and the City upon receipt of this bid shall be via the "Clarification Tab" within ProcureWare. Any other communication will be considered unofficial and non-binding on the City of Spokane.	I agree and I acknowledge
PAYMENT TERMS			
	#1	Vendor acknowledges that payment shall be made Net 30 via direct deposit/ACH (except as provided by state law) after receipt of the goods/services ordered. A completed ACH application is required before a City order will be issued. If the City objects to all or any portion of an invoice, it shall notify the supplier and reserve the right to pay only that portion of the invoice not in dispute. In that event, all parties shall immediately make every effort to settle the disputed amount.	I agree and I acknowledge

CONTACT INFORMATION			
#1	Person's Name, Title, Email Address, and Phone Number submitting Bid.	Patty Maher pmaher@dupillgroup.com 509-375-0774	
CITY OF SPOKANE BUSINESS REGISTRATION REQUIREMENT			
#1	Section 8.01.070 of the Spokane Municipal Code states that no person may engage in business with the City without first having obtained a valid annual business registration. The Bidder shall be responsible for contacting the State of Washington Business License Services at www.dor.wa.gov or 1-360-705-6741 to obtain a business registration. If the Bidder does not believe it is required to obtain a business registration, it may contact the City's Taxes and Licenses Division at (509) 625-6070 to request an exemption status determination.	I agree and I acknowledge	
#2	City of Spokane Business Registration Number	N/A	
ORGANIZATION			
#3	Organization: Bidder Should Enter If Proposal Is of an Individual, Partnership, Corporation, and Existing Under The Laws of What US State. Enter Information Here	Corporation	
TERMS AND CONDITIONS			
#1	Bidder acknowledges that they have read and understand the Terms and Conditions Document in the "Documents" tab. If answer is "I don't agree and I don't acknowledge", include requested exception in proposal submittal on separate page and title as "Exception to Terms and Conditions". The City will consider and determine if exception will be accepted.	I agree and I acknowledge	
#2	EXCEPTION: If you took exception above, upload here.		
ADDITIONAL ITEMS			
#1	The City of Spokane reserves the right to purchase additional items at the quoted price. Supplier agrees to sell at the same price, terms and conditions.	I acknowledge	
PROPRIETARY INFORMATION/PUBLIC DISCLOSURE			
#1	All materials submitted to the City in response to this competitive procurement shall become the property of the City.	I agree and I acknowledge	

#2	<p>All materials received by the City are public records and are subject to being released pursuant to a valid public records request. Washington state law mandates that all documents used, received or produced by a governmental entity are presumptively public records, and there are few exemptions. RCW Ch. 41.56.</p>	I agree and I acknowledge
#3	<p>When responding to this competitive procurement, please consider that what you submit will be a public record. If you believe that some part of your response constitutes legally protected proprietary information, you MUST submit those portions of your response as a separate part of your response, and you MUST label it as "PROPRIETARY INFORMATION." If a valid public records request is then received by the City for this information, you will be given notice and a 10-day opportunity to go to court to obtain an injunction to prevent the City from releasing this part of your response. If no injunction is obtained, the City is legally required to release the records.</p>	I agree and I acknowledge
#4	<p>The City will neither look for nor honor any claims of "proprietary information" that are not within the separate part of your response.</p>	I agree and I acknowledge
<p><b>MINORITY BUSINESS ENTERPRISE</b></p>		
#1	<p>Vendor (is ____, is not ____) a Minority Business Enterprise. A Minority Business Enterprise is defined as a "business, privately or publicly owned, at least 51% of which is owned by minority group members." For purpose of this definition, minority group members are Blacks, Hispanics, Asian Americans, American Indian or Alaskan Natives, or Women.</p>	IS NOT
<p><b>SMALL BUSINESS</b></p>		
#1	<p>Vendor (is ____, is not ____) a small business concern. (A small business concern for the purpose of government procurement is a concern, including its affiliates, which is independently owned and operated, is not dominant in the field of operations in which it is bidding on government contracts, and can further qualify under the criteria concerning number of employees, average annual receipts, or other criteria as prescribed by the Small Business Administration).</p>	IS
<p><b>NON-COLLUSION</b></p>		
<p> </p>		

#1	The Bidder certifies that his/her firm has not entered into any agreement of any nature whatsoever to fix, maintain, increase or reduce the prices or competition regarding the items covered by this ITB.	I certify
INTERLOCAL PURCHASE AGREEMENTS		
#1	The City of Spokane has entered into Interlocal Purchase Agreements with other public Agencies pursuant to chapter 39.34 RCW. In submitting a response, the Proposer agrees to provide its services to other public Agencies at the same contracted price, terms and conditions it is providing to the City of Spokane, contingent upon the Firm's review and approval at the time of a requested contract. The Firm's right to refuse to enter into a contract with another public Agency at the time of request shall be absolute.	Yes
ACCEPTANCE PERIOD		
#1	Bidders must provide a minimum of seventy-five (75) calendar days for acceptance by the City from the due date for receipt of Bids.	I acknowledge
CONTRACT PERIOD		
#1	The contract shall begin upon approval by City Council and terminate 5-years from the date on the Value Blanket Order. The City may choose from more than one vendor. Orders will be placed as-needed throughout contract term with a blanket order process. Payment will be made only for orders placed, received, and accepted.	I agree and I acknowledge
DELIVERY DEFAULT		
#1	A. The acceptance of late performance by the Purchaser shall not waive the right to claim damage for such breach nor constitute a waiver of the requirements for the timely performance of any obligations remaining to be performed by Vendor. B. When items ordered are not delivered within the terms and time frame established by the contract, Purchaser may procure comparable units from another source and Vendor will be required to pay any differences in cost.	I agree and I acknowledge
PCB CERTIFICATION		

#1	In accordance with SMC 7.06.172(A), the Bidder certifies that the products bid and to be supplied (to include product packaging) do not contain polychlorinated biphenyls (PCB's). Moreover and consistent with SMC 7.06.172(B), the City of Spokane, at its sole discretion, may require (at no cost to the City) the apparent successful bidder to provide testing data (prior to contract execution or issue of purchase order) from an accredited laboratory or testing facility documenting the proposed products and or product packaging polychlorinated biphenyl levels.	No
#2	As far as you know has this type product been tested for PCBs by a WA State accredited lab using EPA Method 1668c (or equivalent as updated)?	Don't Know
#3	If so were PCBs found at a measureable level?	Don't Know
#4	As far as you know has this actual product been tested for PCBs by a WA State accredited lab using EPA Method 1668 (or equivalent as updated)?	Don't Know
#5	If so attach the results or note from whom the results can be obtained.	N/A
#6	Do you have reason to believe the product contains measureable levels of PCBs?	Don't Know
#7	Do you have reason to believe the product packaging contains measurable levels of PCBs?	Don't Know
<b>GENERAL INSTRUCTIONS</b>		
#1	The items to be furnished by the Bidder on this Quote must be of the latest possible design and production.	I agree and I acknowledge
#2	Time is of the essence in the performance of this contract.	I agree and I acknowledge
#3	Successful bidder will designate a representative who will be available during regular City business hours to serve as a primary contact for the City in the implementation of this supply agreement and if any issues arise regarding the product.	I agree and I acknowledge
#4	The City of Spokane reserves the right to accept or reject any variance from the published specifications and to award the Quote in a manner that is most advantageous to the continued efficient operation of the City.	I agree and I acknowledge
#5	The City reserves the right to accept or reject any part of or all Bids and to accept the Bid(s) deemed to be in the best interest of the City. The City may choose from more than one vendor.	I agree and I acknowledge

#6	The City of Spokane reserves the option of awarding this purchase by item grouping or by any manner most advantageous for the City.	I agree and I acknowledge
#7	Bidder should be aware that Quotes may be rejected if all questions are not completely and correctly answered.	I agree and I acknowledge
SPECIAL INSTRUCTIONS - GENERAL		
#1	If the product differs from the provisions contained herein, these differences must be explained in detail.	I agree and I acknowledge
#2	Suppliers found to have "overstated" the true ability of their product shall reimburse the City for all costs incurred with remanufacturing or replacement of units until all criteria has been satisfied. These costs shall also include legal, rentals, travel, etc.	I agree and I acknowledge
#3	The omission of any standard feature described herein shall not void the bidder's responsibility to furnish a complete unit with all standard equipment of the manufacturer's latest model and design. Equipment to be furnished shall be new and unused unless a demo unit is specified.	I agree and I acknowledge
#4	Successful bidder shall furnish standard warranty, Stated Warranty Here:	standard mfg. warranty
#5	Federal and State laws governing this product and its final certification must be satisfied.	I agree and I acknowledge
#6	It shall be the Supplier's responsibility to conform to all Federal Standards for certification.	I agree and I acknowledge
#7	Delivery time shall be a consideration of awarding this contract. Therefore the City requests a completed delivery date as soon as possible after receipt of the purchase order.	I agree and I acknowledge
TECHNICAL SPECIFICATIONS		
#1	Any technical specifications and general provisions listed are the minimum acceptable requirements and failure to comply may be used as a basis for rejection of the Bid.	I agree and I acknowledge
#2	Any references herein to a particular make or model number are intended not to be restrictive, but to set forth an acceptable level of quality and design.	I agree and I acknowledge
#3	All items delivered must adhere to stated specs, No Substitutes will be considered in regard to stated Spec'd Valves and Repair Kits due to standardization of valves currently employed within the City of Spokane Waste To Energy Facility.	I agree and I acknowledge



#4	Any delivered item that does not meet specifications will not be accepted.	I agree and I acknowledge
#5	Awarded Supplier would be responsible for providing, spec'd Valves and Repair Kits as needed, listed on "Pricing Form".	I agree and I acknowledge
#6	Bidders must submit cover letters stating qualifications for supplying specified product on contract with the City of Spokane. State name(s) and address(es) of Original Equipment Manufacturer (OEM) and distributors (if applicable) to be used in the production and delivery of valve. Upload Letter	City of Spokane cover letter 6079-24.docx
#7	References are to be included with Bid Proposal forms. Bidder shall furnish names, addresses, telephone numbers, and email addresses of representatives of at least two companies/municipalities which have been continually using the product being bid for at least two years. If no references are completely applicable, provide two references which most nearly apply. References must be located in similar climates.	Ferguson Plumbing Supply 1130 W Washington St, Pasco, WA 99301 (509) 545-2111 Applied Control Equipment LLLP 13705 Compark Boulevard Englewood, CO, 80112 (425) 489-3266
#8	As applicable, Safety Data Sheets must be included with Bid Proposal. Upload Here	
#9	If you took exception to #1 through #8 above, explain in detail.	
<b>INTERPRETATION</b>		
#1.	If the Bidder discovers any errors, discrepancies or omissions in the Bid specifications, or has any questions about the specifications, the Bidder must notify Purchasing in writing. Any addenda issued by the Purchaser will be incorporated into the contract or purchase order.	I agree and I acknowledge
<b>WITHDRAWAL OF BIDS</b>		
#1.	Bidders may withdrawal Bids prior to the scheduled bid due date and time. Unless otherwise specified, no Bids may be withdrawn for a minimum of seventy-five (75) calendar days after the due date.	I agree and I acknowledge
<b>EVALUATION OF BIDS</b>		

	<p>Shall be based upon the following criteria, where applicable: A. The price, including sales tax and the effect of discounts. Price may be determined by life cycle costing or total cost quoting, when advantageous to the Purchaser. B. The quality of the items quoted, their conformity to specifications and the purpose for which they are required. C. The Bidder's ability to provide prompt and efficient service and/or delivery. D. The character, integrity, reputation, judgment, experience and efficiency of the Bidder. E. The quality of performance of previous contracts or services. F. The previous and existing compliance by the Bidder with the laws relating to the contract or services. G. Uniformity or interchangeability. H. The energy efficiency of the product throughout its life. J. Any other information having a bearing on the decision to award the contract.</p>	<p>I agree and I acknowledge</p>
<p><b>BIDDING ERRORS</b></p>		
	<p>Unit pricing will prevail in the circumstance of unit and extension pricing discrepancies. When, after the opening and tabulation of Bids, a Bidder claims error, and requests to be relieved of award, he will be required to promptly present certified work sheets. The Purchaser will review the work sheets and if the Purchaser is convinced, by clear and convincing evidence, that an honest, mathematically excusable error or critical omission of costs has been made, the Bidder may be relieved of his Bid.</p>	<p>I agree and I acknowledge</p>
<p><b>BIDDER PREQUALIFICATION</b></p>		
	<p>The Purchaser reserves the right to reject any or all Bids; to waive minor deviations from the specifications, to waive any informality in Bids received, whenever it is in the Purchaser's best interest, and to accept or reject all or part of this Bid at prices shown.</p>	<p>I acknowledge</p>
<p><b>REJECTION OF BIDS</b></p>		
	<p>The Purchaser reserves the right to reject any or all Bids; to waive minor deviations from the specifications, to waive any informality in Bids received, whenever it is in the Purchaser's best interest, and to accept or reject all or part of this Bid at prices shown.</p>	<p>I agree and I acknowledge</p>
<p><b>AWARD OF CONTRACT(s)</b></p>		
<p></p>		

<p>#1.</p>	<p>Award of contract(s) shall begin upon approval by City Council, will be to the Bidder(s) whose Bid is the most favorable to the Purchaser, taking into consideration price and the other evaluation factors. INTERLOCAL AND STATE CONTRACTS WHERE APPLICABLE WILL BE CONSIDERED AS A BID. Unsuccessful Bidders will not automatically be notified of Quote results.</p>	<p>I agree and I acknowledge</p>
<p>#2</p>	<p>Estimated annual expenditures for the Purchase of new valves and valve kits is estimated at \$300,000. This is an estimate only and the City of Spokane does not guarantee it.</p>	<p>I agree and I acknowledge</p>
<p>#3</p>	<p>It is the intent of this bid to enter into a five (5) year contract(s) for the as-needed purchases of new Valves and Valve Kits as-needed. Orders will be placed as-needed throughout the contract term with a blanket order process. Quantities, when used, are estimates only and are given for the purpose of comparing bids on a uniform basis. Quantities shall be bid on a more or less basis. Actual usage may be more or less. Orders will be placed as needed throughout contract term with a blanket order process. Payment would only be made for actual orders placed, delivered, and accepted.</p>	<p>I agree and I acknowledge</p>
<p>#3.1</p>	<p>It is anticipated that multiple blanket orders will be issued based on Vendors' ability to provide spec'd value and repair kits, and to allow the City the flexibility to allocate requirements among awarded Vendors based upon lead times to best meet City's needs. Bidders are encouraged to bid on as many of the spec'd valve and repair kits that is able to supply. Award of contract(s), when and if made, will be to the bidder(s) whose bid is the most favorable to the City. Contract is optional (non-exclusive) use. The City Council shall make the award of contract(s). Resulting Contract are optional (non-exclusive) use.</p>	<p>I agree and I acknowledge</p>
<p>DELIVERY - F.O.B. Delivery Point</p>		
<p>#1</p>	<p>Spokane Solid Waste Disposal, WTEF, Attn: Shipping and Receiving, 2900 S. Geiger Blvd, Spokane WA, 99224-5400.</p>	<p>I agree and I acknowledge</p>
<p>#2</p>	<p>Freight Transportation: Will be prepaid and add; and listed as a separate line item on invoices. The City reserves the right to request copies of all freight invoices incurred by vendor.</p>	<p>Agree, Pre-Pay and Add</p>

#3	Risk of Loss. Regardless of F.O.B. point, Vendor agrees to bear all risks of loss, injury or destruction of items ordered herein which occur prior to delivery; such loss, injury or destruction shall not release Vendor from any obligation hereunder.	I acknowledge
#4	If you took exception to any of the above, explain in detail.	
PRICING		
#1	Sales Tax: The City of Spokane is not a tax exempt entity and is therefore obligated to pay sales tax under Washington State law. Sales tax should --not-- be included in bidder's unit pricing. All submissions shall be tabulated by the City who with the applicable sales tax rate whether that tax shall be charged through the supplier or paid by the City as use tax.	To Be Supplied
#2	Quantities shown on "Pricing Form" are estimates only and are not to be construed as firm or guaranteed. Quantities, when used, are estimates only and are given for the purpose of comparing bids on a uniform basis. Quantities shall be bid on a more or less basis. Actual usage may be more or less. Orders will be placed as needed throughout contract term with a blanket order process. Payment would only be made for actual orders placed, delivered, and accepted.	I agree and I acknowledge
#3	Bidder MUST complete and upload "Pricing Pages ITB 6079-24" from Documents Tab. Bidders are encouraged to bid on all spec'd valve and repair kits that is able to supply. If document is not uploaded, Bidder will not be considered a responsible bidder. Upload Here.	new ITB 6079-24 Pricing Pages (Addendum 2).pdf
#3.1	PRICING - FIRM FIXED PRICE. Pricing submitted on "Pricing Page" must be a firm fixed price for a 6-month period from the bid due date. Pricing adjustment request will be considered six-months from the bid due date, and then on the annual anniversary of the award, and then every six-months from anniversary of award, with vendor providing justification.	I don't agree and I don't acknowledge
#3.2	All price adjustments must be agreed on by both parties. Vendor must request pricing adjustment in writing, and cannot be applied retroactively to orders already placed with the Vendor. Price increases must apply to all or broad classes of customers and shall in no way single out the Purchaser.	I agree and I acknowledge

#3.3	Back up documentation from manufacturer and/or other sources must be included to justify request. The United States published indices such as the Producer Price Index (PPI), or other government data, may be referenced to help substantiate the Vendor's documentation.	I agree and I acknowledge
#3.4	Adjustments to pricing shall be to not produce a higher profit margin.	I agree and I acknowledge
#3.5	The City of Spokane reserves the right to cancel the contract if the escalation of price is not advantageous to the City.	I agree and I acknowledge
#4	PRICE DECREASES: During the contract period, any price decreases obtained by Contractor shall be reflected in a contract price reduction to the Purchaser retroactive to the Contractor's effective date	I agree and I acknowledge
#5	Additional Value and Repair Kits. Additional Valves and Repair Kits, not currently listed on the pricing page.	Yes
#5.1	VENDOR'S PERCENTAGE DISCOUNT: Should additional Values and Repair Kits be needed that are not currently listed on Pricing Page, but may be realized are needed at a later point in time, Vendor shall provide Vendor's Percentage Discount off Vendor's List Price, to arrive at a Unit Price Cost. Enter Vendor's Percentage Discount on pricing page.	I agree and I acknowledge
#5.1.1	Vendor's Percentage Discount offered will remain unchanged throughout the life of the contract.	I agree and I acknowledge
#5.2	VENDOR'S PERCENTAGE MARK UP: Should Vendor "not" provide percentage discount, Vendor shall provide Vendor's Percentage Mark Up above Vendor's List Price, for additional Valves and Repair Kits not currently listed on Pricing Page, but may be realized are needed at a later point in time. Enter Vendor's Percentage Mark Up on pricing page.	I agree and I acknowledge
#5.2.1	Percentage Markup will remain unchanged throughout the life of the contract.	I agree and I acknowledge
#6	Bidder is aware of if it does not offer either a Percentage Discount or a Percentage Markup, (Either-Or, Not Both), then any resulting Value Blanket will only be able to be utilized to procure items that are listed on the pricing page.	I agree and I acknowledge
ADDITIONAL DOCUMENTS BIDDER WOULD LIKE TO UPLOAD		

<p>#1</p>	<p>Should Bidder Want To Upload Any Additional Document(s) Please Do So Here. ***Please Note: Should Bidder Want To Add More Than One Document, ensure all documents are combined into a single document prior to uploading as bidder would only be able to upload one document here.</p>	<p>DataSheets all line items.pdf</p>
<p>#2</p>	<p>Should Bidder Want To Upload Any Additional Document(s) Please Do So Here. ***Please Note: Should Bidder Want To Add More Than One Document, ensure all documents are combined into a single document prior to uploading as bidder would only be able to upload one document here.</p>	
<p>#3</p>	<p>Should Bidder Want To Upload Any Additional Document(s) Please Do So Here. ***Please Note: Should Bidder Want To Add More Than One Document, ensure all documents are combined into a single document prior to uploading as bidder would only be able to upload one document here.</p>	
<p>#4</p>	<p>Should Bidder Want To Upload Any Additional Document(s) Please Do So Here. ***Please Note: Should Bidder Want To Add More Than One Document, ensure all documents are combined into a single document prior to uploading as bidder would only be able to upload one document here.</p>	
<p>#5</p>	<p>Should Bidder Want To Upload Any Additional Document(s) Please Do So Here. ***Please Note: Should Bidder Want To Add More Than One Document, ensure all documents are combined into a single document prior to uploading as bidder would only be able to upload one document here.</p>	

BIDDER MUST COMPLETE THESE PAGES AND UPLOAD INTO THE CITY OF SPOKANE'S ELECTRONIC BIDDING SYSTEM

ITB 6079-24 Valves and Repair Kits As-Needed (Addendum 2; 3-18-2023)

Annual Quantities shown on "Pricing Form" are estimates only and are not to be construed as firm or guaranteed. Quantities, when used, are estimates only and are given for the purpose of comparing bids on a uniform basis. Quantities shall be bid on a more or less basis. Actual usage may be more or less. Orders will be placed as needed throughout contract term with a blanket order process. Payment would only be made for actual orders placed, delivered, and accepted.

Freight Transportation: Will be prepaid and add; and listed as a separate line item on invoices. The City reserves the right to request copies of all freight invoices incurred by vendor.

Bidders are encouraged to bid on as many of the spec'd valve and repair kits that is able to supply.

Pricing submitted on "Pricing Page" must be a firm fixed price for a 6-month period from the bid due date. Pricing adjustment request will be considered six-months from the bid due date, and then on the annual anniversary of the award, and then every six-months from anniversary of award, with vendor providing justification.

Percentage Discount:	VENDOR'S PERCENTAGE DISCOUNT: Should additional Values and Repair Kits be needed that are not currently listed on Pricing Page, but may be realized are needed at a later point in time, Vendor shall provide Vendor's Percentage Discount off Vendor's List Price, to arrive at a Unit Price Cost. Vendor's Percentage Discount offered will remain unchanged throughout the life of the contract. Enter Vendor's Percentage Discount.	Percentage Discount:	_____ %
Percentage Markup:	VENDOR'S PERCENTAGE MARK UP: <b>Should Vendor "not" provide percentage discount</b> , Vendor shall provide Vendor's Percentage Mark Up above Vendor's List Price, for additional Valves and Repair Kits not currently listed on Pricing Page, but may be realized are needed at a later point in time. Percentage Markup will remain unchanged throughout the life of the contract. Enter Vendor's Percentage Markup.	Percentage Markup:	<u>30</u> %

Bidder is aware of if it does not offer either a Percentage Discount or a Percentage Markup, (E. ither-Or, Not Both), then any resulting Value Blanket will only be able to be utilized to procure items that are listed.

Item	Valve Specification	Manufacturer	PN	Quote Valve Size (inch)	Alternative Valve Manufacturer (if different than provided)	Alternative PN (if different than provided)	Annual Estimated Qty 1 (More or Less)	Price per valve (USD)	Estimated Lead Time After Receipt of Order	VENDOR NOTES
1	Ball, 150 lb, threaded, bronze body, SS ball, TFE seats, wrench operated.	Crane	9302S	1	APOLLO	70LF-145-01		\$148.84	10 WEEKS ARO	
2	Ball, double seal, 600 lb, socket weld, 3-piece isolated body, 316 SS body end and trim, TFE seats, wrench operated.	Worcester	466TSW	1	WORCESTER/FLOWSERVE	10446666TTSW		\$600.00	5 WEEKS ARO	
3	Ball, double seal, 300 lb, flanged RF, end or top entry, cast steel body, monel trim, reinforced TFE seats, for dry chlorine service, wrench operated	Worcester	CL5247T300	1	WORCESTER/FLOWSERVE	10F5255C7RT7-Z300W002		\$3,026.49	10 WEEKS ARO	Valve Size: NPS 1.00" / DN 25mm - Valve Type: Ball Valve (Unibody, 2-Way, End Entry) - Valve Port Size: Reduced Port - Product Series: Worcester 52 New - Valve Pressure Class (ASME): ASME Class 300 - Material: Body: Carbon Steel (Low Temperature) LCB ASTM A352 LCB Casting - Material: Body Seal: PTFE (Virgin) - Non-Pigmented Virgin Plastic - Material: Thrust Seal: PTFE (Reinforced) - 25% Glass Filled Plastic - Material: Stem Seal: Graphite (Grafoil GTK) GTK - Material: End Plug: Carbon Steel (Low Temperature) LCB ASTM A352 LCB Casting - Material: Ball: Hastelloy C-276 ASTM B574 Bar and Rod - Material: Stem: Monel 400 ASTM B164 Bar and Rod - Valve Body End Connection (primary): 300# Flange - Valve Design: Fire-Rated: Yes - Compliance: Fire-Safe (API 607): Yes.
4	Ball, double seal, 150 lb, threaded, end entry, 316 SS body and trim, TFE, wrench operated	Worcester	4866RSE	1	WORCESTER/FLOWSERVE	10446666RTSE		\$630.61	5 WEEKS ARO	
5	Ball, double seal, 600 lb, socket weld, 3-piece, C.S. body, 316 SS trim, TFE seats, wrench operated	Worcester	446TSW	1	WORCESTER/FLOWSERVE	10446666RTSE		\$600.00	5 WEEKS ARO	
6	Check, dual disc, 125 lb, wafer, FF, Buna-N seat, cast iron body, 316 SS hinge pin and spring,	Mueller	71AHB3H	4	TITAN FLOW	CV41-DI		\$233.34	2-3 WEEKS	
7	Check, piston, 600 lb, socket weld bolted welded, union or no bonnet, integral seat, forged steel body, hard faced trim,	Vogt	SW701	1	OMB	840		\$71.90	STOCK - 2 WEEKS	
8	Check, swing, 125 lb, flanged FF, bolted bonnet, renew seat, iron body bronze trim	Crane	373	4	FNW	671B		\$757.33	STOCK - 2 WEEKS	
9	Check, swing, 150 lb, flanged RF, bolted bonnet, renew seat, cast steel body, 13% CR-SS trim	Powell	1561A	4				\$920.41	2-3 WEEKS	
10	Check, dual disc, 150 lb, wafer, RF, Buna-N seat, cast steel body SS hinge pin and spring,	Mission	15SMF	4	CHAMPION	CVR15-CSBS-R		\$964.10	2 WEEKS ARO	
11	Check, swing, 150 lb, threaded, screwed in bonnet, integral seat, all bronze	Crane	137	1	FNW	1241		\$65.20	STOCK - 2 WEEKS	
12	Check, lift, 900 lb, butt weld, pressure seal bonnet, welded in seat, cast steel body, hard faced trim	Crane	7140U7	4	POWELL	1965JCSGXXX		\$5,732.66	32 WEEKS ARO	
13	Check, lift, 1500 lb, socket weld, seal welded bonnet, integral seat, Fl or F22 forged steel body, hard faced trim	Vogt	SW2611	1				\$1,824.53	22 WEEKS ARO	
14	Check, swing, 300 lb, butt weld, bolted bonnet, renew seat, cast steel body, 13% CR-SS trim	Powell	3061A - WE	4				\$1,404.09	2-3 WEEKS	
15	Check, dual disc, 150 lb, wafer RF, Buna-N seat, 316 SS body and trim,	Mission	15CMF	4	CHAMPION	CVR15-SSBS-R		\$1,627.81	2 WEEK ARO	
16	Check, Horizontal lift, 125 lb, flanged ff, two piece body, cast iron body, polypropylene lined	Dow	255	1	XOMOX	75		\$9,535.51	2-3 WEEKS	
17	Check, lift, 6000 lb, tube fitting ends, integral seat 316 SS body and trim tube	Nupro swagelok	SS-58S8	0.50	DK-LOK	VL36C-D-8T-S		\$268.87	5-6 WEEKS	

18	Check, swing, 150 lb, butt weld, bolted bonnet, renew seat, cast steel body, 13% CR-SS trim,	Powell	1561A - WE	4				\$1,102.04	2-3 WEEKS	
19	Diaphragm, weir type, 125 lb, flanged FF, cast iron body polypropylene lined, hypalon diaphragm, travel stop and indicating stem,	Grinnell	2538-2-C	4	GEMU	675		\$2,755.10	2-3 WEEKS	Diaphragm valve, manually operated, metal handwheel, metal distance piece, optical position indicator 2/2-way body Flanges ANSI Class 150 RF, Face to face MSS SP-88 PP lined, CSM, Manually operated with lockable handwheel,(without proprietary padlock
20	Butterfly, 150 lb, wafer, cast iron body, molded in Buna-N seat, DI disc, SS stem, lever operated	Crane	21F-FRB-T92	4	FNW	731B		\$226.63	STOCK - 2 WEEKS	
21	Butterfly, 150 lb, wafer, cast iron body, molded in Buna-N seat, DI disc, SS stem,	Crane	42F-FXB-G41	4	FNW	731B		\$226.63	STOCK - 2 WEEKS	
22	Butterfly, high performance 150 lb, wafer 316 SS body and trim	Turline	801-66-HT1	4	FNW	HPA1WSTL		\$1,299.10	STOCK - 2 WEEKS	
23	Gate, 150 lb, flanged, RF, OS&Y, bolt bonnet, solid or flex wedge, renew seats, cast steel body, 13% Cr-stainless trim	Crane	47XU-F	4	FNW	551		\$853.57	STOCK - 2 WEEKS	
24	Gate, 125 lb, flanged, FF, OS&Y bolted bonnet, solid wedge, renew seats, iron body, bronze trim	Crane	465 - 1/2	4	FNW	651B		\$859.39	STOCK - 2 WEEKS	
25	Gate, 600 or 800 lb, socket weld, OS&Y, bolted or welded bonnet, renew seats, Forged steel body, 13% Cr.-SS trim	Vogt	SW12111	1	OMB	810		\$74.63	STOCK - 2 WEEKS	
26	Gate, 900 lb, butt weld, OS&Y, pressure seal bonnet, flex wedge, welded in seat rings, Cast steel body, hard faced trim	Crane	783U	4	POWELL	1903JCSGXXX		\$7,524.49	2-3 WEEKS	
27	Gate, 2500 lb, socket weld, OS&Y, seal welded bonnet, solid wedge, integral seats, Forged Fil, Cr.-Moly steel body	Vogt	SW-66713	1				\$1,976.96	22 WEEKS ARO	
28	Gate, 900 lb, butt weld, OS&Y, pressure seal bonnet, flex wedge, welded in seat rings, Cast steel body, hard faced trim,	Crane	783-U7	4	POWELL	1903		\$7,524.49	2-3 WEEKS	
29	Gate, 150 lb, butt weld, OS&Y, bolted bonnet, solid or flex wedge, renew seats, cast steel body, 13% Cr-stainless trim,	Crane	47 - 1/2XU	4	POWELL	1503		\$1,416.33	2-3 WEEKS	
30	Gate, 150 lb, threaded, OS&Y, bolted bonnet, solid wedge, integral seats, all iron,	Crane	484 -1/2	1	POWELL	3462		\$224.49	2-3 WEEKS	
31	Gate, 150 lb, flanged, RF, OS&Y, bolted bonnet, split wedge, integral seats, 316 SS body and trim,	Crane	61276-AM	4	FNW	451A		\$2,559.19	STOCK - 2 WEEKS	
32	Gate, 300 lb, butt weld, OS&Y, bolted bonnet, solid or flex wedge, renew seats, cast steel body, 13% Cr-stainless trim	Crane	33- 1/2 XU	4	POWELL	3031		\$1,981.63	2-3 WEEKS	
33	Gate, 150 lb, threaded, ISRS, union bonnet solid wedge, integral seats, bronze body and trim,	Crane	431 - UB	1	APOLLO	107T1		\$173.16	2-3 WEEKS	
34	Knife gate, 125 lb, flanged with one special drilling flange at 27° for level instrument isolation. 316 SS body and all wetted	DeZurik	0300 FIG.	3	FNW	2020TIVT		\$2,734.51	STOCK - 2 WEEKS	
35	Globe, 600 lb, socket weld, OS&Y, bolted or welded bonnet, integral seat, plug type disc, forged steel body, hard faced trim,	Vogt	SW 12141	1	OMB	830		\$88.29	STOCK - 2 WEEKS	
36	Globe, 1500 lb, socket weld, OS&Y, seal welded or integral bonnet, integral seat, plug type disc, Fil or F22 Cr-Moly steel	Vogt	SW15821	1				\$807.47	22 WEEKS ARO	
37	Globe, 150 lb, flanged, RF, OS&Y, bolted bonnet, integral seat, plug type disc, 316 SS body and trim,	Crane	61376-GL	4	POWELL	2475		\$4,679.59	2-3 WEEKS	
38	Globe, 5000 lb, tube fitting ends, union bonnet, plug type disc, integral seat, 316SS body and trim,	Parker	42-V4LN-SS	0.50	DK-LOK	V15B-DZ-4T-R-S		\$75.96	2-3 WEEKS	
39	Globe 300 lb, butt weld, OS&Y, bolted bonnet, renew seat, plug type disc, cast steel body, 13% cr-ss trim	Powell	3031WE	4				\$1,981.63	2-3 WEEKS	
40	Plug, lubricated, 175 lb, threaded bolted cover, tapered plug, Cast iron body and plug,	Powell	2200	1	NORDSTROM	142 ILS		\$301.86	STOCK - 2 WEEKS	
41	Plug, lubricated, 175 lb, flanged FF, bolted cover, tapered plug, cast iron body and plug,	Powell	2201	1	NORDSTROM	143 ILS		\$301.53	3-4 WEEKS	
42	Throttling needle valve - ASME pressure class 1700, 117 bar. 1/8" Orifice Body A105, 4250 CWP.	Yarway	5817	1				\$11,034.70	16-18 WEEKS ARO	
43	Clampseal throttling valve - ASME pressure class 900 , 1/8" orifice. The body material we would like specified is SA105. The ASME pressure class is 900.	Conval	NA	1				\$7,340.81	12 WEEKS ARO	THROTTLING, SW, 1/8" ORF, IGW 1" 900# Ltd. 90° Angle Pattern Throttling valve, SA105 body, cobalt alloy disc and 440C seat and 1/8" orifice, socket weld ends, T-handle operated
44	Eccentric Plug Valve with positioner and actuator Reference RUST Specification Sheet, located in Document Tab.	Fisher Controls	V500	6				\$40,462.80	25 WEEKS ARO	NPS 6 V500 2052 Size 2 3610J TAG: 03-LCV-9150
44.1	Rebuild or repair kit for Fisher V500 valve. Reference RUST Specification Sheet, located in Document Tab.	Fisher Controls	Reference RUST Specification Sheet, located in Document Tab.	6				\$22,981.43	5 WEEKS ARO	NPS 6 V500 Repair Parts. Includes: Valve Plug, Drive Shaft, Seat Ring, Face Seals, Bearings and Packing Parts.



Adrienne Eldridge  
Fluid Controls and Components, Inc.  
3095 Kingsgate Way  
Richland, WA 99354

adrienne@dupillgroup.com

509-375-0774

APRIL 8, 2024

Dear City of Spokane,

I am writing to submit my bid for RFQ **6079-24** as listed on the City of Spokane portal. We are excited to be considered for this opportunity and believe that FCCI having over 20 years of experience making us a strong candidate to successfully complete this project.

I have attached our detailed proposal outlining the scope of work, timeline, and pricing for your review. In addition to our technical expertise, we are committed to delivering high-quality products and exceeding your expectations. Our team is well-prepared to take on this project and ensure its successful completion.

We understand the importance of this project to the City of Spokane and the potential impact it can have on your goals. Our proposal is tailored to address the specific needs and objectives outlined in your request for bid.

I am confident that our team has the knowledge, skills, and dedication to deliver a solution that not only meets but exceeds your expectations. We are eager to work closely with you to ensure the success of this project.

If you have any questions or would like to discuss any aspect of our proposal further, please feel free to contact me at 509-375-0774 or adrienne@dupillgroup.com. I am available at your convenience and am eager to collaborate with your team to bring this project to fruition.

Due to the volatile market of metals FCCI can only guarantee pricing for 30 days on all line items.

Thank you for considering our bid, we look forward to the opportunity to work with the City of Spokane on this exciting project.

Procuring product from vendors that we have been doing business with for 10 + years.

Ferguson Plumbing Supply  
1130 W Washington St,  
Pasco, WA 99301  
(509) 545-2111

Applied Control Equipment LLLP  
13705 Compark Boulevard  
Englewood, CO, 80112  
(425) 489-3266

Sincerely,

Adrienne Eldridge

# 70LF-100 Series

NPT Bronze Ball Valve

## LEAD FREE

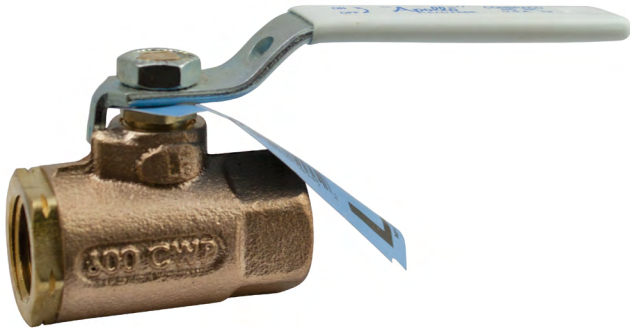

Job Name:	
Job Location:	
Engineer:	
Contractor:	
Tag:	
PO#:	
Rep.:	
Wholesale Dist.:	

### DESCRIPTION

The Apollo 70LF Series two-piece regular port ball valve has the same rugged features as the industry standard 70 Series valves with the added advantage of DZR lead free\* materials. The 70LF is ideal for plumbing and heating systems, including potable water. Trusted Apollo® performance with a wide range of popular options.

### FEATURES

- EZ-Solder™ Lead Free\* Brass & Bronze Materials
- Distinctive White "Lead Free" Handle Grip and Blue "Lead Free" Hang Tag
- RPTFE Seats and Stuffing Box Ring
- Chromium Plated Ball
- **Designed, Manufactured and 100% Factory Tested in the USA**

### PERFORMANCE RATING

- CWP: 600 psi (41.37 Bar) at 100°F
- SWP: 150 psi (10.34 Bar) at 366°F
- Maximum Temperature: 350°F
- Vacuum Service to 29 in. Hg

### MODELS

- 70LF-100 Series - Standard
- 70LF-140 Series - 316 SS Ball & Stem

### APPROVALS

- MSS SP-110 - Ball Valves Threaded, Socket-Welding, Solder Joint, Grooved and Flared Ends
- NSF/ANSI 61 - Water Quality
- NSF/ANSI 372 - Lead Free
- CRN: OC10908.5C

### OPTIONS

- (-04) 2-1/4" CS Stem Extension 1/4" - 3"
- (-07) Steel Tee Handle 1/4" - 2"
- (-10) SS Lever & Nut 1/4" - 3"
- (-11) Therma-Seal™ Insulating Tee Handle 1/4" - 2"
- (-27) SS Latch-Lock Lever & Nut 1/4" - 4"
- (-92) Balancing Stop 1/4" - 3"
- (-94) -04 Option & Balancing Stop 1/4" - 3"
- (-HC) Hose Cap & Chain 1/2" - 1"

### STANDARD MATERIALS LIST

<b>LEVER / GRIP</b>	Steel, Zinc Plated w/ Vinyl Grip
<b>STEM PACKING</b>	MPTFE
<b>STEM BEARING</b>	RPTFE
<b>BALL</b>	C27451, Lead Free Brass, Cr Plated
<b>SEAT (2)</b>	RPTFE
<b>RETAINER</b>	C27451 Lead Free Brass (1/4" to 1") C89836 Lead Free Bronze (1-1/4" - 4")
<b>GLAND NUT</b>	B16 Brass
<b>STEM</b>	C27451 Lead Free* Brass A276-316 Stainless Steel (3" only)
<b>LEVER NUT</b>	Steel, Zinc Plated
<b>BODY</b>	C89836 Lead Free* Bronze

### DIMENSIONS

PART NUMBER	SIZE (IN.)	DIMENSIONS (IN.)					WT. (LB.)
		A	B	C	D	E	
70LF-101-01	1/4"	0.37	1.03	2.06	1.75	3.87	0.60
70LF-102-01	3/8"	0.37	1.03	2.06	1.75	3.87	0.56
70LF-103-01	1/2"	0.50	1.12	2.25	1.75	3.87	0.63
70LF-104-01	3/4"	0.68	1.50	3.00	2.12	4.87	1.39
70LF-105-01	1"	0.87	1.68	3.37	2.25	4.87	1.72
70LF-106-01	1-1/4"	1.00	2.00	4.00	2.62	5.50	3.26
70LF-107-01	1-1/2"	1.25	2.18	4.37	3.06	8.00	4.61
70LF-108-01	2"	1.50	2.34	4.68	3.25	8.00	6.06
70LF-109-01	2-1/2"	2.00	3.12	6.25	3.72	8.00	13.96
70LF-100-01	3"	2.50	3.37	6.75	4.12	8.00	18.60
70LF-10A-01	4"	3.12	3.68	7.37	5.25	10.00	25.50

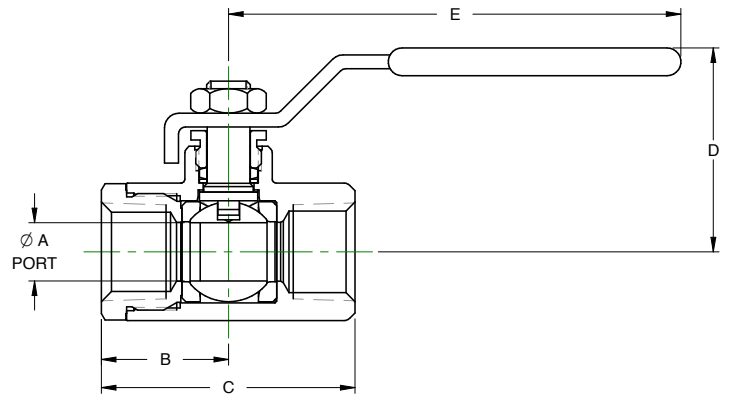

\*LEAD FREE: The wetted surfaces of this product shall contain no more than 0.25% lead by weighted average. Complies with Federal Public Law 111-380. ANSI 3rd party approved and listed.



**TITAN FLOW CONTROL, Inc.**

290 Corporate Drive  
Lumberton, NC 28358  
Tel: 910.735.0000

E-mail: titan@titanfci.com  
Web: www.titanfci.com  
Fax: 910.738.3848

**CHECK VALVE • WAFER TYPE • DUAL DISC**

**MODEL: CV 41-DI (Ductile Iron Body)**

Buna-N, Viton, or EPDM Seats  
Stainless Steel or Bronze Discs

ANSI  
Class  
150

**BILL OF MATERIALS <sup>(1)</sup>**

No.	PART	CV 41-DI <sup>(2)</sup>
1	Body	Ductile Iron ASTM A536
2	Seat	Buna-N, Viton, or EPDM
3	Disc	Aluminum Bronze or Series 300 Stainless Steel
4	Spring <sup>(2)</sup>	Series 300 Stainless Steel
5	Shaft/Stop Pin	Series 300 Stainless Steel
6	NPT Plug	Commercial Steel
7	Eye Bolt <sup>(4)</sup>	Commercial Steel

- Bill of Materials represents standard materials. Equivalent or better materials may be substituted at the manufacturer's discretion.
- Denotes recommended spare parts.
- Ductile Iron bodies are epoxy painted.
- Eye Bolt is available on larger sizes only.

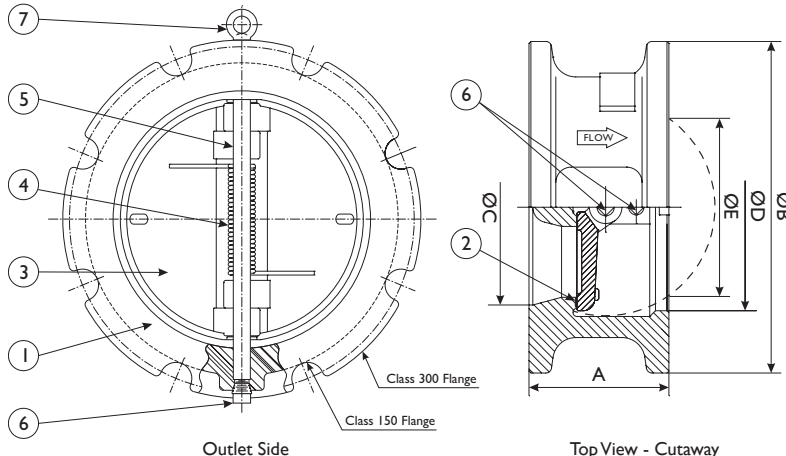

CAD illustration is representative of sizes 2" through 6". Sizes 8" through 24" are not scalloped. Sizes 2" through 6" are designed for dual pressure service (ANSI Class 150 and 300).

**Ductile Iron Application Notes:**

Ductile Iron maintains the anti-corrosive properties of Cast Iron while achieving a yield strength comparable to Carbon Steel. Ductile Iron also offers higher pressure/temperature ratings than Cast Iron. For example, Ductile Iron check valves (class 300 - sizes 2" ~ 24") are rated at 640 psi WOG. By comparison, Cast Iron check valves (class 250 - sizes 2" ~ 12") are rated at 500 psi WOG and (sizes 14" ~ 24") are only rated at 300 psi WOG. Ductile Iron ANSI Classes 150 and 300 have the same bolting pattern as Cast Iron ANSI Classes 125 and 250 respectively.

**DIMENSIONS AND PERFORMANCE DATA <sup>(1)</sup>**

SIZE	DIMENSIONS AND PERFORMANCE DATA <sup>(1)</sup>														
	in	2	2 1/2	3	4	5	6	8	10	12	14	16	18	20	24
	mm	50	65	80	100	125	150	200	250	300	350	400	450	500	600
A DIMENSION FACE TO FACE <sup>(2)</sup>	in	2.12	2.12	2.25	2.50	2.75	3.00	3.75	4.25	5.62	7.25	7.50	8.00	8.37	8.75
	mm	54	54	58	64	70	77	96	108	143	185	191	204	213	223
ØB DIMENSION OUTLET OUTSIDE DIAMETER	in	4.37	5.12	5.75	7.12	8.50	9.87	11.00	13.37	16.12	17.75	20.25	21.62	23.87	28.25
	mm	111	131	146	181	216	251	280	340	410	451	515	550	607	718
ØC DIMENSION INLET INSIDE DIAMETER	in	2.00	2.50	3.00	4.00	5.00	6.00	8.00	10.00	12.00	14.00	16.00	18.00	20.00	24.00
	mm	51	64	77	102	127	153	204	254	305	356	407	458	508	610
ØD DIMENSION OUTLET INSIDE DIAMETER	in	2.62	3.12	3.87	4.75	6.00	7.00	9.00	11.00	13.25	14.25	16.25	18.12	20.12	24.00
	mm	67	80	98	121	152	178	229	280	337	362	413	461	512	610
ØE DIMENSION MINIMUM BORE DIAMETER	in	0	1.26	2.36	3.425	4.567	5.315	7.48	9.45	11.26	11.26	13.70	15.63	17.638	21.97
	mm	0	32	60	87	116	135	190	240	286	286	348	397	448	558
ASSEMBLED WEIGHT	lb	4.0	5.0	7.0	14.0	18.0	26.5	43.0	70.0	108.0	175.0	200.0	258.0	345.0	460.0
	kg	1.8	2.3	3.2	6.3	8.2	12.0	19.5	31.7	48.9	79.4	90.7	117.0	156.5	208.7
Flow Coefficient	C <sub>v</sub>	62	110	175	350	550	850	1500	2400	3700	5400	8250	10400	14200	23000
Cracking Pressure <sup>(3)</sup>	psi	≤ .25	≤ .25	≤ .25	≤ .25	≤ .25	≤ .25	≤ .25	≤ .25	≤ .25	≤ .25	≤ .25	≤ .25	≤ .25	≤ .25

- Dimensions and weights are for reference only. When required, request certified drawings.
- Face to face values have a tolerance of ±0.06 in (±2.0 mm) for sizes 10" and lower and a tolerance of ±0.12 in (±3.0 mm) for sizes 12" and larger.
- Cracking pressure is for horizontal installations only. For vertical installations, please consult factory.

**PRESSURE - TEMPERATURE RATINGS <sup>(1)</sup>**

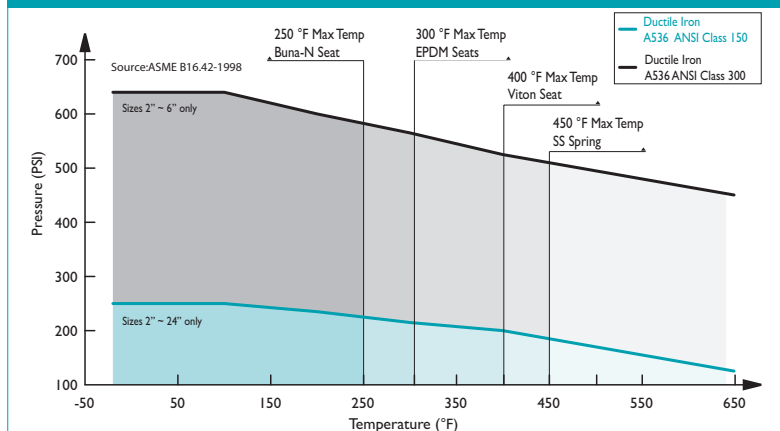

- The above chart displays the pressure-temperature ratings for the valve's body material per ASME B16.42-1998. Max temperature limits have been added for seat and spring materials. Sizes 2" through 6" are dual pressure rated for both ANSI Class 150 and 300.

Titan FCI makes every effort to ensure the information presented on our literature accurately reflects exact product specifications. However, as product changes occur, there may be short-term differences between actual product specifications and the information contained within our literature. Titan FCI reserves the right to make design and specification changes to improve our products without prior notification. When required, request certified drawings.

**REFERENCED STANDARDS & CODES**

CODE	DESCRIPTION
ANSI/API 594	Valve Design and Manufacture
ASME/ANSI 16.5	Flange Dimensions
ASME/ANSI B16.34	Valves - Flanged, Threaded, and Welding End
ASME/ANSI B16.42	Ductile Iron Pipe Flanges and Flanged Fittings
API 598	Valve Inspection and Pressure Test
FM APPROVALS CLASS 1230	Anti-Water Hammer Check Valves (2" ~ 12")

**PRESSURE / TEMPERATURE RATING - ASTM A536**

Body Material	Class 150 (2" ~ 24")	Class 300 (2" ~ 6")
WOG (Non-shock):	250 PSI @ 100 °F	640 PSI @ 100 °F

**SEAT AND SPRING TEMPERATURE RATING**

Seat Material	Range	Spring Material	Max
EPDM:	-30 ~ 300 °F	Series 300 Stainless Steel:	450 °F
BUNA-N:	-20 ~ 250 °F		
VITON:	-40 ~ 400 °F		



# CHECK VALVES SECTION



Check valves are uni-directional valves which automatically open with forward flow and close against reverse flow. They are supplied to meet a wide variety of applications with the closing element in the piston, ball or swing type. Piston check valves are normally supplied by OMB with the addition of a spring which allows both the vertical and horizontal installation.

Great care is given by OMB employees in the design and in manufacturing to prevent noisy operation and unsatisfactory wear of closure components.

The full range of OMB production is reported on pages 32 to 37.

**Figure # is identified in each table as:**

STANDARD PORT	PISTON	840	-
	BALL	850	
	SWING	860	
FULL PORT	PISTON	640	1/A
	BALL	650	
	SWING	660	

CLASS	DESIGN	CONNECTION	PORT	STANDARD	SCREW & YOKE	ENDS	PAGE	OMB FIG.
800	Piston	Bolted bonnet	Regular	ISO15761	Outside	Threaded and Socket Weld Ends	33	840
800	Piston	Bolted bonnet	Full	ISO15761	Outside	Threaded and Socket Weld Ends	33	640
800	Ball	Bolted bonnet	Regular	ISO15761	Outside	Threaded and Socket Weld Ends	33	850
800	Ball	Bolted bonnet	Full	ISO15761	Outside	Threaded and Socket Weld Ends	33	650
800	Swing	Bolted bonnet	Regular	ISO15761	Outside	Threaded and Socket Weld Ends	33	860
800	Swing	Bolted bonnet	Full	ISO15761	Outside	Threaded and Socket Weld Ends	33	660
800	Piston	Welded Bonnet	Regular	ISO15761	Outside	Threaded and Socket Weld Ends	33	L840
800	Piston	Welded Bonnet	Full	ISO15761	Outside	Threaded and Socket Weld Ends	33	L640
800	Ball	Welded Bonnet	Regular	ISO15761	Outside	Threaded and Socket Weld Ends	33	L850
800	Ball	Welded Bonnet	Full	ISO15761	Outside	Threaded and Socket Weld Ends	33	L650
1500	Piston	Bolted bonnet	Regular	ISO15761	Outside	Threaded and Socket Weld Ends	33	R940
1500	Piston	Bolted bonnet	Full	ISO15761	Outside	Threaded and Socket Weld Ends	33	940
1500	Ball	Bolted bonnet	Regular	ISO15761	Outside	Threaded and Socket Weld Ends	33	R950
1500	Ball	Bolted bonnet	Full	ISO15761	Outside	Threaded and Socket Weld Ends	33	950
1500	Swing	Bolted bonnet	Regular	ISO15761	Outside	Threaded and Socket Weld Ends	33	R960
1500	Piston	Welded Bonnet	Regular	ISO15761	Outside	Threaded and Socket Weld Ends	33	LR940
1500	Piston	Welded Bonnet	Full	ISO15761	Outside	Threaded and Socket Weld Ends	33	L940
1500	Ball	Welded Bonnet	Regular	ISO15761	Outside	Threaded and Socket Weld Ends	33	LR950
1500	Ball	Welded Bonnet	Full	ISO15761	Outside	Threaded and Socket Weld Ends	33	L950
1500	Swing	Bolted bonnet	Full	ISO15761	Outside	Threaded and Socket Weld Ends	33	960
1500	Piston	Ring Joint BB	Full	ANSI B16.34	Outside	Threaded and Socket Weld Ends	34	RJ940
1500	Ball	Ring Joint BB	Full	ANSI B16.34	Outside	Threaded and Socket Weld Ends	34	RJ950
1500	Swing	Ring Joint BB	Full	ANSI B16.34	Outside	Threaded and Socket Weld Ends	34	RJ960
2500	Piston	Ring Joint BB	Full	ANSI B16.34	Outside	Threaded and Socket Weld Ends	34	RJ2540
2500	Ball	Ring Joint BB	Full	ANSI B16.34	Outside	Threaded and Socket Weld Ends	34	RJ2550
2500	Piston	Welded Bonnet	Full	ANSI B16.34	Outside	Threaded and Socket Weld Ends	34	L2540
2500	Ball	Welded Bonnet	Full	ANSI B16.34	Outside	Threaded and Socket Weld Ends	34	L2550
4500	Piston	Ring Joint BB	Full	ANSI B16.34	Outside	Threaded and Socket Weld Ends	34	RJ4540
4500	Ball	Ring Joint BB	Full	ANSI B16.34	Outside	Threaded and Socket Weld Ends	34	RJ4550
800	Piston Y Pattern	Welded Bonnet	Full	ISO15761	Outside	Threaded and Socket Weld Ends	35	Y640
1500	Piston Y Pattern	Welded Bonnet	Full	ANSI B16.34	Outside	Threaded and Socket Weld Ends	35	Y940
2500	Piston Y Pattern	Welded Bonnet	Full	ANSI B16.34	Outside	Threaded and Socket Weld Ends	35	Y2540
4500	Piston	Welded Bonnet	Full	ANSI B16.34	Outside	Threaded and Socket Weld Ends	35	Y4540
150	Piston	Bolted bonnet	Regular	ISO15761	Outside	Flanged	36	F1-840
150	Ball	Bolted bonnet	Regular	ISO15761	Outside	Flanged	36	F1-850
300	Piston	Bolted bonnet	Regular	ISO15761	Outside	Flanged	36	F3-840
300	Ball	Bolted bonnet	Regular	ISO15761	Outside	Flanged	36	F3-850
600	Piston	Bolted bonnet	Regular	ISO15761	Outside	Flanged	36	F6-840
150	Swing	Bolted bonnet	Regular	ISO15761	Outside	Flanged	36	F1-860
300	Swing	Bolted bonnet	Regular	ISO15761	Outside	Flanged	36	F3-860
600	Swing	Bolted bonnet	Regular	ISO15761	Outside	Flanged	36	F6-860
600	Ball	Bolted bonnet	Regular	ISO15761	Outside	Flanged	36	F6-850
150	Piston	Bolted bonnet	Full	ISO15761	Outside	Flanged	36	F1-640
150	Ball	Bolted bonnet	Full	ISO15761	Outside	Flanged	36	F1-650
300	Piston	Bolted bonnet	Full	ISO15761	Outside	Flanged	36	F3-640
300	Ball	Bolted bonnet	Full	ISO15761	Outside	Flanged	36	F3-650
600	Piston	Bolted bonnet	Full	ISO15761	Outside	Flanged	36	F6-640
600	Ball	Bolted bonnet	Full	ISO15761	Outside	Flanged	36	F6-650
150	Swing	Bolted bonnet	Full	ISO15761	Outside	Flanged	36	F1-660
300	Swing	Ring Joint BB	Full	ISO15761	Outside	Flanged	36	F3-RJ-660
600	Swing	Ring Joint BB	Full	ISO15761	Outside	Flanged	36	F6-RJ-660
1500	Piston	Ring Joint BB	Full	ISO15761	Outside	Flanged	37	F9-RJ-940
1500	Ball	Ring Joint BB	Full	ISO15761	Outside	Flanged	37	F9-RJ-950
1500	Swing	Ring Joint BB	Full	ISO15761	Outside	Flanged	37	F9-RJ-960
2500	Piston	Ring Joint BB	Full	ANSI B16.34	Outside	Flanged	37	F25-RJ-2540
2500	Ball	Ring Joint BB	Full	ANSI B16.34	Outside	Flanged	37	F25-RJ-2550
2500	Swing	Ring Joint BB	Full	ANSI B16.34	Outside	Flanged	37	F25-RJ-2560
1500	Piston Y Pattern	Welded Bonnet	Full	ISO15761	Outside	Flanged	37	9-Y940
2500	Piston Y Pattern	Welded Bonnet	Full	ANSI B16.34	Outside	Flanged	37	25-Y2540



## CLASS 800

PISTON, BALL AND SWING TYPE - STANDART PORT TO API602/ISO 15761 - FULL PORT TO BS 5352  
Bolted Cover - Threaded and Socket Weld Ends

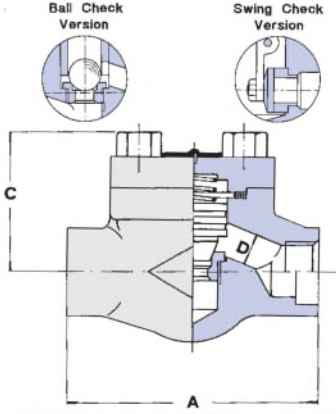

RATINGS: Carbon Steel - 1975 p.s.i. @ 100°F

STANDARD PORT		PISTON 840	-		1/2		3/4		1		1.1/4		1.1/2		2		-	
FULL PORT		PISTON 640	1/4		3/8		1/2		3/4		1		1.1/4		1.1/2		2	
		BALL 850																
		SWING 860																
End to End	PISTON - BALL	<b>A</b>	mm	in.	mm	in.	mm	in.	mm	in.	mm	in.	mm	in.	mm	in.	mm	in.
	SWING	<b>A</b>	80	3.14	80	3.14	90	3.54	110	4.33	127	5.00	155	6.10	170	6.69	210	8.26
Center to Top		<b>C</b>	53	2.08	53	2.08	60	2.36	73	2.87	80	3.14	98	3.85	118	4.64	150	5.90
Dia. of Port	PISTON - BALL	<b>D</b>	7	0.28	9	0.35	13	0.51	17.5	0.69	23	0.88	29.5	1.16	35	1.38	45.5	1.79
	SWING	<b>D</b>	8	0.31	9.6	0.38	14	0.55	18	0.70	24	0.94	30	1.18	37	1.45	48	1.89
Approx. Weight	PISTON - BALL	<b>Kg / Lb</b>	1.3	2.8	1.3	2.8	1.4	3.0	2.4	5.2	4.0	8.8	7.4	16.2	8	17.6	18	39.6
	SWING	<b>Kg / Lb</b>	1.3	2.8	1.3	2.8	1.4	3.0	2.4	5.2	4.0	8.8	5.5	12.1	6.5	14.3	17.5	38.5

## CLASS 800

PISTON AND BALL TYPE - STANDART PORT TO API602/ISO 15761 - FULL PORT TO BS 5352  
Welded Cover - Threaded and Socket Weld Ends

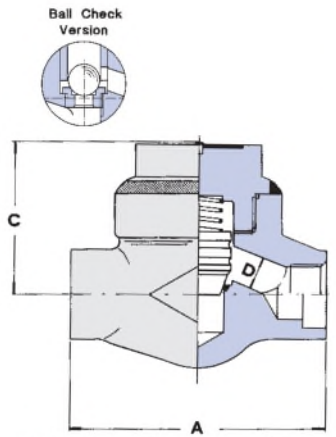

RATINGS: Carbon Steel - 1975 p.s.i. @ 100°F

STANDARD PORT		PISTON L840	-		1/2		3/4		1		1.1/4		1.1/2		2		-	
FULL PORT		BALL L850	1/4		3/8		1/2		3/4		1		1.1/4		1.1/2		2	
		PISTON L640																
		BALL L650																
End to End	<b>A</b>	mm	in.	mm	in.	mm	in.	mm	in.	mm	in.	mm	in.	mm	in.	mm	in.	
	Center to Top	<b>C</b>	53	2.08	53	2.08	60	2.36	73	2.87	80	3.14	98	3.85	110	4.33	150	5.90
Dia. of Port	<b>D</b>	7	0.28	9	0.35	13	0.51	17.5	0.69	23	0.88	29.5	1.16	35	1.37	45.5	1.79	
Approx. Weight	<b>Kg / Lb</b>	1.3	2.8	1.3	2.8	1.4	3.0	2.4	5.2	4.0	8.8	7.4	16.3	8	17.6	17	37.4	

## CLASS 1500

PISTON, BALL AND SWING TYPE - STANDART PORT TO API602/ISO 15761 - FULL PORT TO BS 5352  
Bolted Cover - Threaded and Socket Weld Ends

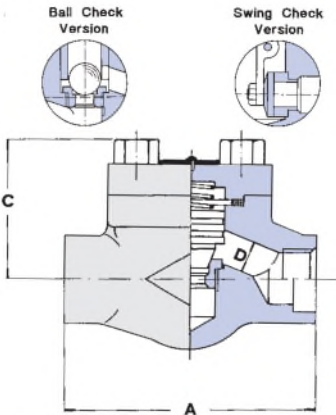

RATINGS: Carbon Steel - 3705 p.s.i. @ 100°F

STANDARD PORT		PISTON R940	-		1/2		3/4		1		1.1/4		1.1/2		2		-	
FULL PORT		BALL R950	1/4		3/8		1/2		3/4		1		1.1/4		1.1/2		2	
		SWING R960																
		PISTON 940																
		BALL 950																
		SWING 960																
End to End	PISTON - BALL	<b>A</b>	mm	in.	mm	in.	mm	in.	mm	in.	mm	in.	mm	in.	mm	in.	mm	in.
	SWING	<b>A</b>	90	3.54	90	3.54	110	4.33	127	5.00	155	6.10	170	6.69	210	8.26	210	8.26
Center to Top		<b>C</b>	60	2.36	60	2.36	73	2.87	80	3.14	98	3.85	118	4.64	150	5.90	150	5.90
Dia. of Port	PISTON - BALL	<b>D</b>	7	0.28	9	0.35	13	0.51	17.5	0.69	21	0.83	28	1.10	33	1.30	37.5	1.48
	SWING	<b>D</b>	8	0.31	9.6	0.38	14	0.55	18	0.70	24	0.94	30	1.18	37	1.45	40	1.57
Approx. Weight	PISTON - BALL	<b>Kg / Lb</b>	1.5	3.3	1.5	3.3	2.8	6.1	4.6	10.1	7.4	16.2	9	19.8	19.5	49.9	19	41.8
	SWING	<b>Kg / Lb</b>	1.6	3.5	1.5	3.3	2.4	5.2	4	8.8	6	13.2	9.5	20.9	19	41.8	18.5	40.7

## CLASS 1500

PISTON AND BALL TYPE - STANDART PORT TO API602/ISO 15761 - FULL PORT TO BS 5352  
Welded Cover - Threaded and Socket Weld Ends

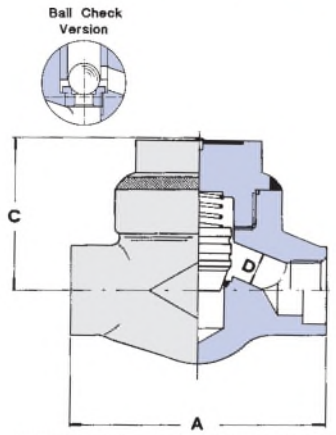

RATINGS: Carbon Steel - 3705 p.s.i. @ 100°F

STANDARD PORT		PISTON LR940	-		1/2		3/4		1		1.1/4		1.1/2		2		-	
FULL PORT		BALL LR950	1/4		3/8		1/2		3/4		1		1.1/4		1.1/2		2	
		PISTON L940																
		BALL L950																
End to End	<b>A</b>	mm	in.	mm	in.	mm	in.	mm	in.	mm	in.	mm	in.	mm	in.	mm	in.	
	Center to Top	<b>C</b>	60	2.36	60	2.36	73	2.87	80	3.14	98	3.85	110	4.33	150	5.90	150	5.90
Dia. of Port	<b>D</b>	7	0.28	9	0.35	13	0.51	17	0.67	21	0.83	28	1.10	33	1.30	37.5	1.47	
Approx. Weight	<b>Kg / Lb</b>	1.5	3.3	1.5	3.3	2.8	6.1	4.6	10.1	7.4	16.3	9	19.8	15	33.0	14.5	31.9	

# FIGURE 671B CAST IRON VALVES



## 125# FLANGED 200 WOG IBBM SWING CHECK VALVE

### FEATURES

- 200 psi WOG non-shock (-20°F to 150°F)
- 125 psi WSP (125 psi at 450°F)
- Flat faced flanges
- Horizontal swing
- Horizontal installation or vertical with upward flow

### PRODUCT SPECIFICATIONS

#### Standards

- Class 125 flanges: ANSI B16.1
- Pressure/temperature rating: MSS SP-71
- Face to face dimensions: ANSI B16.10
- Design and testing: MSS SP-71



### CV & WEIGHT

SIZE	Cv	Wt. (Lbs)
2	45	25
2-1/2	75	36
3	110	46
4	210	81
5	345	115
6	530	150
8	1010	253
10	1580	442
12	2460	638

### TEMPERATURE/PRESSURE\*

Temp (°F)	Pressure (PSI)
-20 to 150	200
200	190
225	180
250	175
275	170
300	165
325	155
350	150
375	145
400	140
425	130
450	125

\*P/T listed is for 2" to 12" 200 WOG ASTM A126 Class B gray iron valves. Temperatures shown are that of the pressure containing parts of the valve and are assumed to be equal to the contained fluid's temperature. Use of a pressure rating at a pressure containing temperature other than the contained fluid's is at the responsibility of the end-user.

### DIMENSIONS (INCHES)

SIZE	Port	H	L	C	D	T	nxh
2	2.00	4.65	8.00	4.75	6.00	0.62	4x3/4
2-1/2	2.50	5.37	8.50	5.50	7.00	0.69	4x3/4
3	3.00	5.77	9.50	6.00	7.50	0.75	4x3/4
4	4.00	6.65	11.50	7.50	9.00	0.94	8x3/4
5	5.00	7.78	13.00	8.50	10.00	0.94	8x3/4
6	6.00	8.47	14.00	9.50	11.00	1.00	8x3/4
8	8.00	10.40	19.50	11.75	13.50	1.12	8x3/4
10	10.00	11.91	24.50	14.25	16.00	1.19	12x1
12	12.00	13.52	27.50	17.00	19.00	1.25	12x1

# FIGURE 671B CAST IRON VALVES



125# FLANGED 200 WOG IBBM SWING CHECK VALVE

## PARTS BREAKDOWN

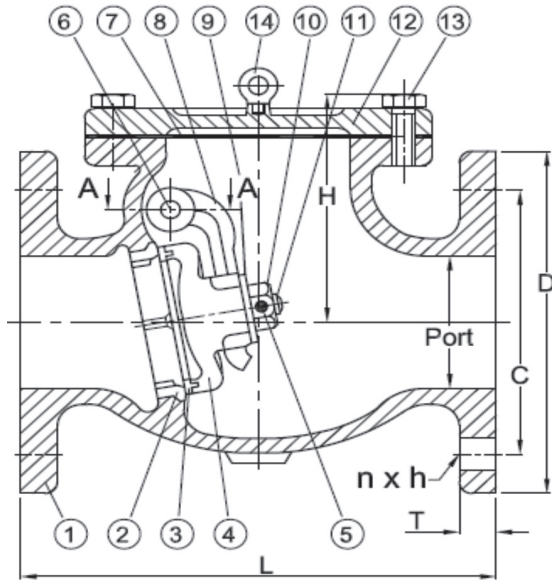
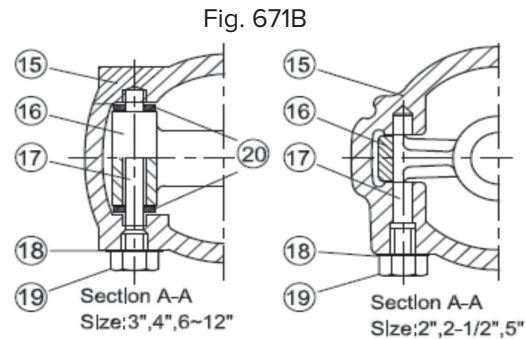

Fig. 671B



## FIGURE NUMBER MATRIX

FNW	671B	Size Code		
		2 = K	4 = P	8 = X
		2-1/2 = L	5 = S	10 = 10
		3 = M	6 = U	12 = 12

## PART MATERIALS & QUANTITY

Ref #	Description	Material	Specification	Qty	Notes
1	Body	Cast Iron	ASTM A126-B	1	
2	Body Seat Ring	Cast Bronze	ASTM B62	1	
3	Disc Seat	Cast Bronze	ASTM B62	1	
4	Disc Seat	Cast Iron	ASTM A126-B	1	2", 2-1/2", 5"
5	Split Pin	Ductile Iron	ASTM A536	1	3", 4", 6" - 12"
6	Hanger Pin	Stainless Steel	ASTM A276-304	1	
7	Gasket	Brass	ASTM B16	1	
8	Hanger	Non-Asbestors		1	
9	Hanger	Steel	ASTM A536	1	
10	Washer	Steel		1	
11	Nut	Steel	ASTM A307-A	1	
12	Full Thread Bolt	Steel	ASTM A307-A	1	2", 2-1/2", 5"
13	Cover	Cast Iron	ASTM A126-B	1	
14	Hex. Head Bolt	Steel	ASTM A307-A	1 Set	
15	Eye Bolt	Stainless Steel	ASTM A276-304	1	6" - 12"
16	Body	Cast Iron	ASTM A126-B	1	
17	Hanger	Ductile Iron	ASTM A536	1	
18	Hanger Pin	Brass	ASTM B16	1	
19	Gasket	Non-Asbestors		1	
20	Side Plug	Brass	ASTM B16	1	
20	Washer	Brass	ASTM B16	2	3", 4", 6" - 12"





**API 600 WALL SWING CHECK VALVES**  
 BOLTED BONNET, ASME CLASSES 150 TO 1500  
 CAST CARBON, STAINLESS STEEL OR ALLOY STEEL

**STANDARD MATERIALS (Other materials available)**

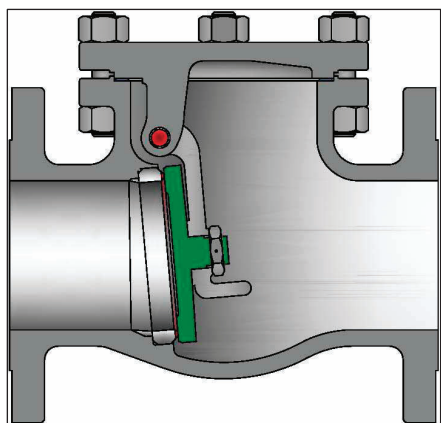

Class	Figure Number
150	1561
300	3061
600	6061
900	9061
1500	1361

PART	MATERIALS			
	A216 Gr. WCB	A217 Gr. WC6	A217 Gr. WC9	A351 Gr. CF8M (2)
Body	A216 Gr. WCB	A217 Gr. WC6	A217 Gr. WC9	A351 Gr. CF8M (2)
Cap	A216 Gr. WCB	A217 Gr. WC6	A217 Gr. WC9	A351 Gr. CF8M
Disc	A105+13% CR Faced or WCB+13% CR Faced	WC6+Stellite 6 Faced	WC9+Stellite 6 Faced	A351 Gr. CF8M
Seat Ring	Carbon Steel + Stellite 6 Faced	A182 F11 + Stellite 6 Faced	A182 F22 + Stellite 6 Faced	316 SST
Gasket	Class 150: Corrugated SST Encapsulated w/ Graphite Class 300 to 600: Spiral Wound SST with Graphite Class 900-1500: RTJ			Class 150: PTFE Class 300-600: Spiral Wound SST with Graphite
Carrier	A216 Gr. WCB	A217 Gr. WC6	A217 Gr. WC9	A351 Gr. CF8M
Carrier Pin	SST 410			316 SST
Disc Nut	Series 300 SST			A193 Gr. B8M
Disc Carrier Hanger (1)	A216 Gr. WCB	A217 Gr. WC6	A217 Gr. WC9	A351 Gr. CF8M
Disc Carrier Hanger Bolts (1)	A193 Gr. B7	A193 Gr. B16		A193 Gr. B8M
Body / Cap Stud	A193 Gr. B7	A193 Gr. B16		A193 Gr. B8
Body / Cap Nut	A194 Gr. 2H	A194 Gr. 7		A194 Gr.8
Identification Plate	Series 300 SST			

(1) 8" Valve size and up. (2) CF3M used for weld end valves.

**DESIGN FEATURES:**

- **Standard trim** is API trim 8 for carbon steel valves, API trim 5 for chrome alloy valves, and API trim 10 for CF8M (T316) valves for optimal performance under normal conditions. Other trim materials available on request.
- **Seat faces** lapped for smooth finish and superior sealing.
- **Wall thickness** per heavy wall API 600 requirements.
- **Swivel disc** for improved seat alignment and longer life.
- **Each** valve is shell and seat pressure tested per industry standard API 598.
- **Check** valves are suitable for service in horizontal line with cap vertical or in a vertical line with flow upward.
- **Carrier Pin** is confined within the body wall and is not accessible from the exterior, thus no side body penetrations, eliminating a common leak path, on classes 150 through 600.
- **End Flanges** have the following raised faces per ASME B16.5:  
 Classes 150-300: 1/16" (2mm).  
 Classes 600-1500: 1/4" (7mm).

**NOTE: See page 52 for flow, safety and maintenance information.**

**Design Specifications**

Item	Applicable Specification
Wall thickness	API 600
Pressure - temperature ratings	ASME B16.34
General valve design	B16.34
End to End dimensions	ASME B16.10
Flange design	ASME B16.5
Butt Weld design	ASME B16.25
Materials	ASTM

- **Each** valve has a unique certification number that is traceable to the valve certification sheet which includes MTR data, pressure test, inspection result and certificate of conformance.
- **Other** available options as follows:  
 -Alternate valve materials such as chrome and stainless steel alloys  
 -Alternate trim materials  
 -Drain and other auxiliary connections  
 -NACE service  
 -Special cleaning for applications such as oxygen or chlorine  
 -Other options available as specified

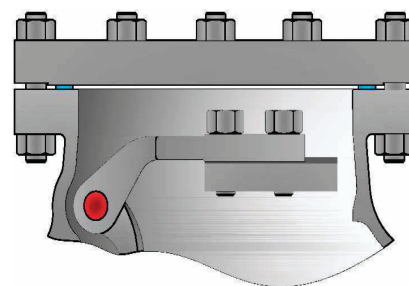

Valve design for valve sizes 8" and above all pressure classes.



**SWING CHECK VALVE DIMENSIONS (CLASS 150–1500).**

SIZE	ASME 150				ASME 300				ASME 600			
	A	B	C	D	A	B	C	D	A	B	C	D
in	WE/FE				WE/FE				WE/FE			
2	8.00	4.9	4.6	2.00	10.50	5.0	4.6	2.00	11.50	6.9	7.3	2.00
50	203	126	118	51	267	126	118	51	292	176	185	51
2 ½	8.50	5.6	6.8	2.50	11.50	5.6	6.8	2.50	13.00	7.4	7.9	2.50
65	216	142	172	64	292	142	172	64	330	189	200	64
3	9.50	5.9	7.7	3.00	12.50	5.9	7.7	3.00	14.00	8.3	8.5	3.00
80	241	149	195	76	318	149	195	76	356	212	215	76
4	11.50	6.5	9.1	4.00	14.00	6.5	9.1	4.00	17.00	10.3	10.6	4.00
100	292	166	230	101	356	166	230	102	432	262	270	102
6	14.00	8.2	10.8	6.00	17.50	8.6	11.8	6.00	22.00	14.0	13.5	6.00
150	356	208	273	152	444	219	298	152	559	356	342	152
8	19.50	11.9	15.1	8.00	21.00	13.3	15.6	8.00	26.00	18.5	17.1	7.87
200	495	302	384	203	533	338	397	203	660	469	435	200
10	24.50	14.2	17.8	10.00	24.50	15.3	18.5	10.00	31.00	21.2	20.1	9.75
250	622	360	450	254	622	389	470	254	787	539	510	248
12	27.50	15.7	21.6	12.00	28.00	17.9	22.3	12.00	33.00	23.4	22.6	11.75
300	698	399	549	305	711	455	565	305	838	594	575	298
14	31.00	22.2	20.9	13.25	33.00	23.4	21.7	13.25	35.00	25.4	23.5	12.87
350	787	565	532	337	838	595	550	337	889	645	598	327
16	34.00	23.6	25.3	15.25	34.00	24.9	27.4	15.25	39.00	28.6	27.6	14.75
400	864	599	642	387	864	632	695	387	991	727	700	375
18	38.50	27.9	29.6	17.25	38.50	28.5	30.4	17.00	43.00	32.5	29.1	16.50
450	978	709	752	438	978	723	772	432	1092	826	740	419
20	38.50	26.7	27.0	19.25	40.00	24.9	29.1	19.00	47.00	31.6	32.3	18.25
500	978	679	685	489	1016	632	738	483	1194	802	820	464
24	51.00	33.5	36.0	23.25	53.00	34.8	37.6	23.00	55.00	40.2	39.4	22.00
600	1295	852	915	591	1346	884	955	584	1397	1020	1000	559

SIZE	ASME 900				ASME 1500			
	A	B	C	D	A	B	C	D
in	WE/FE				WE/FE			
2	14.50	9.6	8.9	1.87	14.50	9.6	8.9	1.87
50	368	244	226	47	368	244	226	47
2 ½	16.50	10.2	9.2	2.25	16.50	10.3	9.2	2.25
65	419	260	235	57	419	260	235	57
3	15.00	10.6	10.2	2.87	18.50	12.6	10.4	2.75
80	381	268	258	73	470	319	265	70
4	18.00	12.9	11.6	3.87	21.50	15.8	15.4	3.62
100	457	328	295	98	546	400	390	92
6	24.00	17	15.8	5.75	27.75	18.4	17.2	5.37
150	610	433	400	146	705	468	435	136
8	29.00	23.6	17.5	7.50	32.75	23.8	20.3	7.00
200	737	600	445	191	832	604	515	178
10	33.00	24.4	22.6	9.37	39.00	25.6	22.4	8.75
250	838	620	575	238	991	650	570	222

**B** = Center to top

**WE** = Butt Weld ends

**FE** = Flanged ends

**ADDITIONAL SIZES, MATERIALS AND CLASSES AVAILABLE UPON REQUEST.**

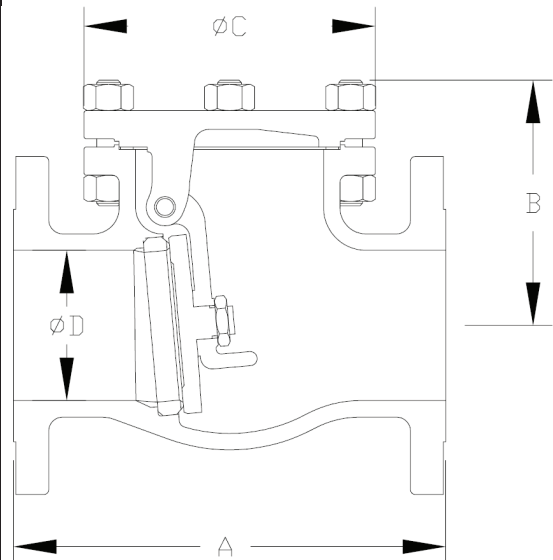

SIZE	ASME 150						ASME 300						ASME 600								
	in	in	WT	lb	WT	lb	C <sub>v</sub>	F	in	WT	lb	WT	lb	C <sub>v</sub>	F	in	WT	lb	WT	lb	C <sub>v</sub>
mm	F	mm	FE	kg	WE	kg		mm	FE	kg	WE	kg	mm		FE	kg	WE	kg			
2	6.0		27		23		75	6.0		34		29		75	8.0		62		49		75
50	155		12		10			155		15		13			205		28		22		
2 ½	7.0		40		35		120	7.0		53		45		120	8.5		79		62		120
65	175		18		16			175		24		21			220		36		28		
3	7.5		53		41		170	7.5		68		58		170	10.0		110		79		170
80	190		24		19			190		31		27			250		50		36		
4	8.5		79		57		320	8.5		110		94		320	12.5		215		168		320
100	215		36		26			220		50		42			315		98		76		
6	11.0		132		113		760	11.5		212		182		760	17.0		439		335		760
150	285		60		51			295		96		82			435		199		152		
8	16.0		337		293		1400	17.5		507		437		1400	22.5		811		633		1300
200	405		153		133			440		230		198			570		368		287		
10	19.0		567		483		2200	20.5		858		728		2200	26.0		1343		1047		2100
250	490		257		219			515		389		330			665		609		475		
12	22.0		873		758		3300	24.0		1160		1077		3300	29.5		1702		1363		3100
300	555		396		344			610		526		488			745		772		618		
14	29.0		979		834		4000	30.0		1411		1241		4000	32.0		1958		1585		3700
350	735		444		378			765		640		563			810		888		719		
16	31.0		1438		1250		5200	32.5		1764		1550		5200	36.0		2994		2364		4900
400	795		652		567			825		800		703			915		1358		1072		
18	36.5		1927		1656		7000	37.0		2578		2192		6800	35.5		3449		2932		6400
450	930		874		751			940		1169		994			900		1564		1330		
20	36.5		1771		1522		8700	34.5		2913		2505		8500	36.5		4792		4121		7800
500	925		803		690			875		1321		1136			925		2174		1869		
24	45.0		3559		3062		13000	46.5		5204		4428		12000	45.0		7608		6467		11000
600	1150		1614		1388			1175		2360		2008			1145		3451		2933		

SIZE	ASME 900						ASME 1500								
	in	F	in	WT	lb	WT	lb	C <sub>v</sub>	F	in	WT	lb	WT	lb	C <sub>v</sub>
mm	mm	FE	kg	WE	kg	mm	FE		kg	WE	kg	mm	FE	kg	
2	10.5		165		132		65		10.5		165		132		65
50	270		75		60				270		75		60		
2 ½	11.5		265		183		100		11.5		265		183		100
65	290		120		83				290		120		83		
3	12.0		209		154		160		14.0		375		271		150
80	305		95		70				355		170		123		
4	15.0		375		271		300		17.5		963		463		260
100	380		170		123				445		437		210		
6	20.0		716		518		700		21.0		1235		1036		600
150	505		325		235				535		560		470		
8	27.5		1257		877		1200		27.5		2271		1907		1100
200	700		570		398				695		1030		865		
10	29.0		1808		1437		1900		30.0		3483		2888		1700
250	740		820		652				760		1580		1310		

F = Dismantling dimension

WE = Butt Weld ends

FE = Flanged ends

WT = Weight

C<sub>v</sub> = Flow coefficient

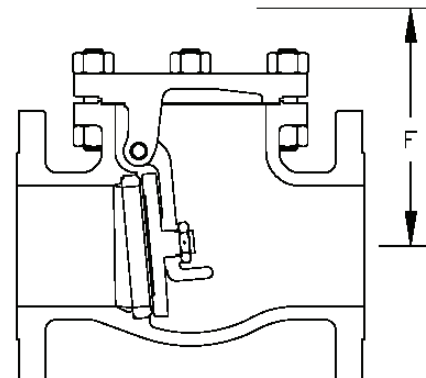



CHAMPION VALVES INC.

# DUAL DISC SPRING LOADED WAFER CHECK VALVE

QUALITY PRODUCTS, SERVICE & RELIABILITY



CHAMPION WAFER CHECK VALVES · SIZE RANGE 2" - 72" · ASME CLASS 125 - 2500

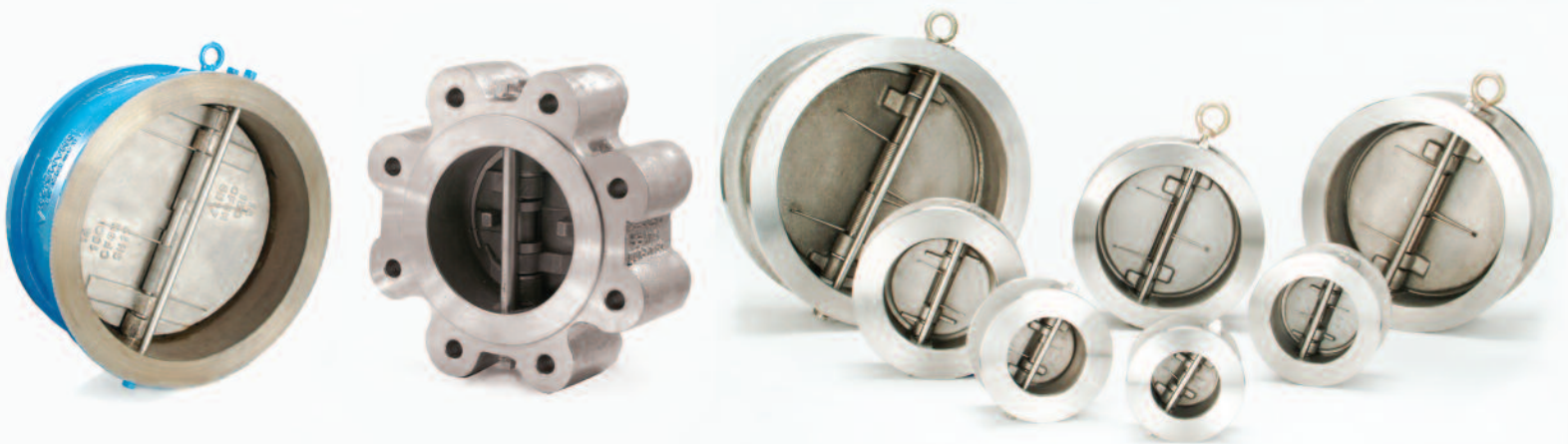

MATERIALS: IRON · CARBON STEEL · STAINLESS STEEL · ALUMINUM BRONZE · ALLOY 20 · MONEL · NICKEL



ISO 9001



# CHAMPION VALVES, INC.

## DUAL DISC SPRING LOADED WAFER CHECK VALVES

FEATURES	BENEFITS
<ul style="list-style-type: none"><li>• Light weight, versatile design — 80% to 90% less than conventional full-body swing check valves</li></ul>	<ul style="list-style-type: none"><li>• Simplifies piping</li><li>• Reduces thermal and seismic considerations</li><li>• Optimizes space utilization</li><li>• Lowers installation costs</li><li>• Reduces pipe supports</li><li>• Requires less number of man-hours</li></ul>
<ul style="list-style-type: none"><li>• Dual Discs open to 85 degrees</li></ul>	<ul style="list-style-type: none"><li>• Low cracking pressure and overall pressure drop</li><li>• Ensures positive closure</li></ul>
<ul style="list-style-type: none"><li>• Spring-loaded discs calculated to increase the responsiveness of the discs</li></ul>	<ul style="list-style-type: none"><li>• Alleviates water hammer and resultant damaging effects</li></ul>
<ul style="list-style-type: none"><li>• Extended long-leg spring</li></ul>	<ul style="list-style-type: none"><li>• Prevents seat wear caused by scrubbing</li></ul>

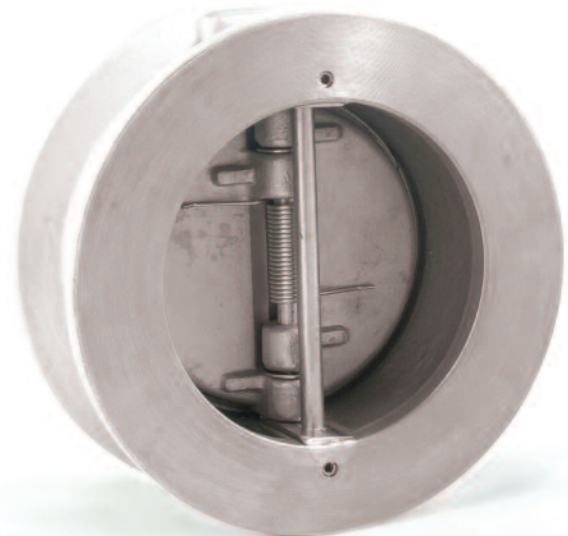
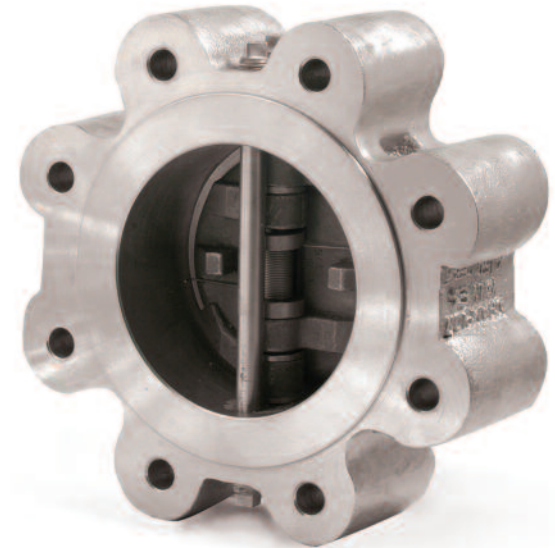

### GENERAL APPLICATION

- General service piping systems
- Water, oil, gasoline, chemicals
- Gas (compressible gases)
- Air (compressed air and blower)

### INSTALLATION

Champion wafer check valves are designed for installation in flanged piping systems, between two flanges. Valves may be installed in vertical or horizontal piping. Care must be taken to always install the valves with the shafts in a vertical position when installing in a horizontal pipeline. Vertical up flow is always a good installation. Consult factory for vertical down flow.

Champion wafer check valves are designed to provide long service life if the velocity is kept within the flow rate shown in the table on page 7 and if a minimum of 5 pipe diameters of straight pipe in front of the valve is maintained downstream from a likely cause of turbulence (i.e., pump discharge, reducers or elbows).

### INDUSTRY STANDARDS

- ASME B16.1, B16.5, B16.34, B16.47 and B31.1
- API 594 and 598 • MSS-SP-25, MSS-SP-55
- API 6A and 6D (as applicable) • MSS-SP-61 (standard for the resilient seated, metal seated when required)

## FIGURE NUMBER INFORMATION

### DUAL DISC - WAFER BODY

STYLE	
CV - Standard Wafer	
CVR - Retainerless Wafer	
ASME/API SERIES	
12	= 125 Class
15	= 150 Class
25	= 250 Class
30	= 300 Class
40	= 400 Class
60	= 600 Class
90	= 900 Class
150	= 1500 Class
250	= 2500 Class

BODY & DISCS		
ORDERING LETTER	MATERIAL	SPECIFICATION
A	Aluminum Bronze	ASTM B148, Alloy 952; BS 1400, Alloy AB2
B	Bronze	ASTM B62, C83600
C	Carbon Steel	ASTM A216, Gr. WCB
D	Duplex	ASTM A351, Gr. CD4MCu
F	Alloy 20®	ASTM A351, Gr. CN7M
G	Cast Iron	ASTM A126; Gr.B
H	Hastelloy C276®	ASTM A494, Gr. CW12MW
J	410 Stainless Steel	ASTM A217, Gr. CA15 (12% Cr)
K	317 Stainless Steel	ASTM A351, Gr. CG8M
L	Ductile Iron	ASTM A395; Gr. 60-40-18
M	Monel®	ASTM A494, Gr. M-35-1
N	Nickel	ASTM A494, Gr. CZ-100
S	316 Stainless Steel	ASTM A351, Gr. CF8M
T	304 Stainless Steel	ASTM A351, Gr. CF8

SEAT			
ORDERING LETTER	MATERIAL	OPERATING TEMPERATURE	
		°C	°F
B	Buna-N®	- 57 to 120	- 70 to 250
E	EPDM	-18 to 135	0 to 300
H	Silicone	-18 to 260	0 to 500
J	410 SS	- 267 to 537	- 450 to 1000+
L	Stellite®	-267 to 537	- 450 to 1000+
N	Neoprene®	- 40 to 120	- 40 to 250
P	Integral Metal	- 267 to 537	- 450 to 1000+
S	316 SS	- 267 to 537	- 450 to 1000+
T	Teflon®	- 40 to 149	- 40 to 300
V	Viton®	- 40 to 204	- 40 to 400

SPRING			
ORDERING LETTER	MATERIAL	OPERATING TEMPERATURE	
		°C	°F
S	316 SS	260	500
M	Monel®	232	450
W	Inconel®	371	700
X	Inconel X-750®	593	1100

END CONNECTION	
ORDERING LETTER	CONNECTIONS
P	Plain Face
R	Serrated Raised Face
RJ	Ring Joint

BODY CONFIGURATION	
ORDERING LETTER	CONFIGURATION
None(Blank)	Wafer style, inserted between mating flanges with studs spanning entire length
1	Lug design with threaded holes bolted from each end
2	Lug design with through-bolt holes to protect studs
3	Double flanged design with valve flanges bolted to individual like flanges

**EXAMPLE:** Specifications Call for 6"(150mm), Wafer Style — Retainerless; ASME 300 Champion Wafer Check; 316 Stainless Steel Body; 316 SS Discs; Metal Seat; & Inconel X-750 Spring; Raised Face End Connection; Through — Bolt Lug Body

#### 6CVR30-SSPX-R2

SIZE	STYLE	PRESSURE CLASS	BODY	DISC	SEAT	SPRING	END CONNECTION	BODY CONFIGURATION	MODIFICATION NUMBER
6"	CVR	30	S	S	P	X	R	2	Assigned by Factory

# STYLE CV & CVR INSTALLATION DIMENSIONS\*

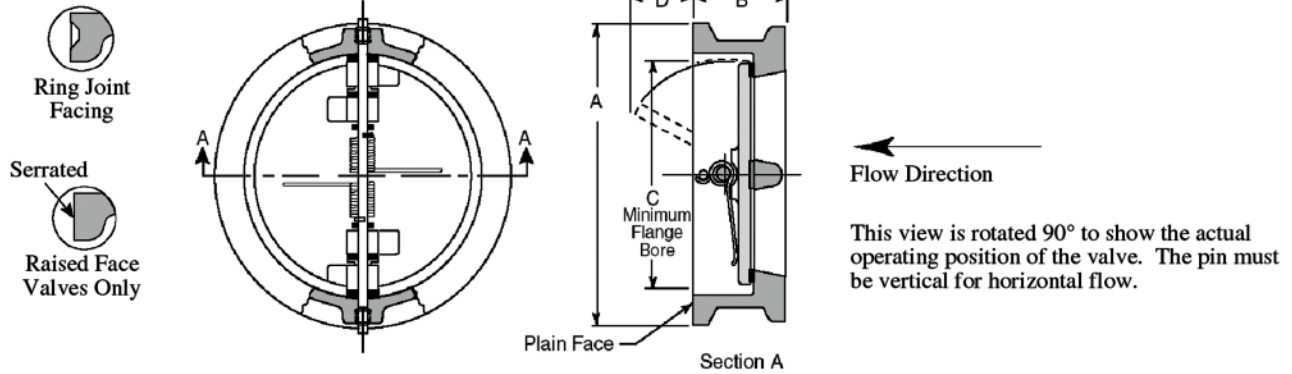

Dimensions for lug and double flange body styles and bolting requirements are available upon request.

## ASME CLASS 125 (Iron Body Valves Only)

Size		A		B		C		D		Weight	
in	mm	in	mm	in	mm	in	mm	in	mm	lbs	kg
2"	50	4 1/8	105	2 1/8	54	2 1/16	52	-	-	4	1.8
2 1/2"	65	4 7/8	124	2 1/8	54	2 15/32	63	-	-	6	2.7
3"	80	5 3/8	137	2 1/4	57	3 1/16	78	5/8	16	7	3.2
4"	100	6 7/8	175	2 1/2	64	4	102	1	25	12	5.4
5"	125	7 3/4	197	2 3/4	70	5	127	1 5/16	33	15	6.8
6"	150	8 3/4	222	3	76	6 1/16	154	1 15/16	35	20	9
8"	200	11	279	3 3/4	95	8	203	3 7/16	54	40	18
10"	250	13 3/8	340	4 1/4	108	10	254	3 3/8	70	65	29
12"	300	16 1/8	410	5 5/8	143	11 15/16	303	3 9/16	83	110	50
14"	350	17 3/4	451	7 1/4	184	12 1/2	318	3 1/16	83	183	83
16"	400	20 1/4	514	7 1/2	191	15	381	4 1/4	113	255	116
18"	450	21 5/8	549	8	203	16 7/8	429	5 3/8	137	315	143
20"	500	23 7/8	606	8 3/8	213	18 13/16	478	6 3/16	160	380	173
24"	600	28 1/4	718	8 3/4	222	22 5/8	575	8 1/4	210	575	261
30"	750	34 3/4	883	12	305	29 1/4	743	9 9/16	229	1070	486
36"	900	41 1/4	1048	14 1/2	368	35	889	12 5/16	303	1962	892
42"	1050	48	1219	17	432	41	1041	15	381	2800	1270
48"	1200	54 1/2	1384	20 5/8	524	47	1194	16 3/4	425	3920	1178

## ASME CLASS 150

Size		A		B		C		D		Weight	
in	mm	in	mm	in	mm	in	mm	in	mm	lbs	kg
2"	50	4 1/8	105	2 3/8	60	1 15/16	49	-	-	6	3
2 1/2"	65	4 7/8	124	2 5/8	67	2 11/32	60	-	-	10	5
3"	80	5 3/8	137	2 7/8	73	2 29/32	74	1/4	6	13	6
4"	100	6 7/8	175	2 7/8	73	3 27/32	97	5/8	16	17	8
5"	125	7 3/4	197	3 3/8	86	4 13/16	122	7/8	22	27	12
6"	150	8 3/4	222	3 7/8	98	5 3/4	146	1 3/8	35	35	16
8"	200	11	279	5	127	7 5/8	194	2 1/8	54	70	32
10"	250	13 3/8	340	5 3/4	146	9 9/16	243	2 3/4	70	106	48
12"	300	16 1/8	410	7 1/8	181	11 3/8	289	3 1/4	83	172	78
14"	350	17 3/4	451	7 1/4	184	12 1/2	318	3 1/4	83	200	91
16"	400	20 1/4	514	7 1/2	191	15	381	4 7/16	113	275	125
18"	450	21 5/8	549	8	203	16 7/8	429	5 3/8	137	315	143
20"	500	23 7/8	606	8 5/8	219	18 13/16	478	6 5/16	160	435	197
24"	600	28 1/4	718	8 3/4	222	22 5/8	575	8 1/4	210	620	281
26"	650	30 1/2	775	14	356	24 1/4	616	8	203	1555	705
30"	750	34 3/4	883	12	305	29 1/4	743	9	229	1230	558
36"	900	41 1/4	1048	14 1/2	368	35	889	12	303	2017	915
42"	1050	48	1219	17	432	41	1041	15	381	2800	1270
48"	1200	54 1/2	1384	20 5/8	524	47	1194	16 3/4	425	3920	1178

\*Approximate weights and dimensions—Apply for certified drawings. Dimensions available with DIN, JIS, AS and ISO. Sizes above 24" per ASME B16.47 Series A. Series B available if required.

# STYLE CV & CVR INSTALLATION DIMENSIONS\* (Continued)

## ASME CLASS 250

Size		A		B		C		D		Weight	
in	mm	in	mm	in	mm	in	mm	in	mm	lbs	kg
2"	50	4 3/8	111	2 1/8	54	1 15/16	49	3/32	2	5	2.3
2 1/2"	65	5 1/8	130	2 3/8	60	2 11/32	60	3/8	10	11	5
3"	80	5 7/8	149	2 5/8	67	2 29/32	74	9/16	14	11	5
4"	100	7 1/8	181	2 5/8	67	3 13/16	96	9/16	14	14	6.4
5"	125	8 1/2	216	3 1/4	83	4 13/16	122	1	25	29	13.2
6"	150	9 7/8	251	3 3/4	95	5 3/4	146	1 1/2	38	35	16
8"	200	12 1/8	308	5	127	7 5/8	194	2 1/8	54	75	34
10"	250	14 1/4	362	5 1/2	140	9 9/16	243	3 1/16	80	113	51
12"	300	16 5/8	422	7 1/8	181	11 3/8	289	3 1/4	83	174	79
14"	350	19 1/8	486	8 3/4	222	12 1/2	318	3 3/16	81	299	136
16"	400	21 1/4	540	9 1/8	232	14 5/16	364	4 1/8	105	380	172
18"	450	23 1/2	597	10 3/8	264	16 7/8	429	4 13/16	122	510	231
20"	500	25 3/4	654	11 1/2	292	17 15/16	456	5 3/8	136	593	269
24"	600	30 1/2	775	12 1/2	318	21 9/16	548	7 1/16	179	1010	458
30"	750	37 1/2	953	14 1/2	368	28 3/4	730	8 13/16	224	1880	853
36"	900	44	1118	19	483	35	889	11 9/16	294	3573	1608
42"	1050	50 3/4	1289	22 3/8	568	41	1041	14 3/4	375	5780	2622
48"	1200	58 3/4	1492	24 3/4	629	47	1194	16 1/2	419	6572	2981

## ASME CLASS 300

Size		A		B		C		D		Weight	
in	mm	in	mm	in	mm	in	mm	in	mm	lbs	kg
2"	50	4 3/8	111	2 3/8	60	1 15/16	49	-	-	7	3
2 1/2"	65	5 1/8	130	2 5/8	67	2 11/32	60	-	-	11	5
3"	80	5 7/8	149	2 7/8	73	2 29/32	74	1/4	6	15	7
4"	100	7 1/8	181	2 7/8	73	3 13/16	96	5/8	16	18	8
5"	125	8 1/2	216	3 3/8	86	4 13/16	122	7/8	22	35	16
6"	150	9 7/8	251	3 7/8	98	5 3/4	146	1 3/8	35	45	20
8"	200	12 1/8	308	5	127	7 5/8	194	2 1/8	54	82	37
10"	250	14 1/4	362	5 3/4	146	9 9/16	243	2 3/4	70	125	57
12"	300	16 5/8	422	7 1/8	181	11 3/8	289	3 1/4	83	200	91
14"	350	19 1/8	486	8 3/4	222	12 1/2	318	3 3/16	81	325	147
16"	400	21 1/4	540	9 1/8	232	14 5/16	364	4 1/8	105	415	188
18"	450	23 1/2	597	10 3/8	264	16 7/8	429	4 13/16	122	555	252
20"	500	25 3/4	654	11 1/2	292	17 15/16	456	5 5/8	143	725	329
24"	600	30 1/2	775	12 1/2	318	21 9/16	548	7 1/16	179	1100	499
26"	650	32 7/8	835	14	356	24 3/8	619	8	203	1605	728
30"	750	37 1/2	953	14 1/2	368	28 3/4	730	9 1/16	230	2050	930
36"	900	44	1118	19	483	35	889	11 3/16	284	3573	1621
42"	1050	50 3/4	1289	22 3/8	568	41	1041	14 3/4	375	5780	2622
48"	1200	58 3/4	1492	24 3/4	629	47	1194	16 1/2	419	6572	2981

## ASME CLASS 600

Size		A		B		C		D		Weight	
in	mm	in	mm	in	mm	in	mm	in	mm	lbs	kg
2"	50	4 3/8	111	2 3/8	60	1 15/16	49	-	-	7	3
2 1/2"	65	5 1/8	130	2 5/8	67	2 11/32	60	1/8	3	11	5
3"	80	5 7/8	149	2 7/8	73	2 29/32	74	1/4	6	15	7
4"	100	7 5/8	194	3 1/8	79	3 13/16	96	7/8	22	26	12
5"	125	9 1/2	241	4 1/8	105	4 13/16	122	1	25	50	22.7
6"	150	10 1/2	267	5 3/8	137	5 3/4	146	1 7/16	36	80	36
8"	200	12 5/8	321	6 1/2	165	7 5/8	194	2	51	135	61
10"	250	15 3/4	400	8 3/8	213	9 9/16	243	2 9/32	58	238	108
12"	300	18	457	9	229	11 3/8	289	3 15/32	88	333	151
14"	350	19 3/8	492	10 3/4	273	12 1/2	318	2 3/4	70	455	206
16"	400	22 1/4	565	12	305	14 5/16	364	4 5/16	110	640	290
18"	450	24 1/8	613	14 1/4	362	16 1/8	410	3 11/16	94	890	404
20"	500	26 7/8	683	14 1/2	368	17 15/16	456	5 5/16	135	1120	508
24"	600	31 1/8	791	17 1/4	438	21 9/16	548	6 9/16	167	2040	925

\*Approximate weights and dimensions—Apply for certified drawings. Dimensions available with DIN, JIS, AS and ISO. Sizes above 24" per ASME B16.47 Series A. Series B available if required.



# STYLE CV & CVR INSTALLATION DIMENSIONS\* (Continued)

## ASME CLASS 900

Size		A		B		C		D		Weight	
in	mm	in	mm	in	mm	in	mm	in	mm	lbs	kg
2"	50	5 5/8	143	2 3/4	70	1 11/16	43	-	-	14	6
2 1/2"	65	6 1/2	165	3 1/4	83	2 1/8	54	1/16	2	16	7
3"	80	6 5/8	168	3 1/4	83	2 5/8	67	5/16	8	24	11
4"	100	8 1/8	206	4	102	3 7/16	87	9/16	14	40	18
5"	125	9 3/4	248	-	-	4 5/16	110	-	-	-	-
6"	150	11 3/8	289	6 1/4	159	5 3/16	132	1 1/16	27	115	52
8"	200	14 1/8	359	8 1/8	206	6 13/16	173	1 13/32	36	229	104
10"	250	17 1/8	435	9 1/2	241	8 1/2	216	1 13/16	46	388	176
12"	300	19 5/8	498	11 1/2	292	10 1/8	257	2 5/16	59	540	245
14"	350	20 1/2	521	14	356	11 1/2	292	2	51	926	420
16"	400	22 5/8	575	15 1/8	384	12 13/16	325	2 5/8	67	1152	523
18"	450	25 1/8	638	17 3/4	451	14 7/16	367	2 9/16	65	1318	598
20"	500	27 1/2	699	17 3/4	451	17 15/16	456	5 5/16	135	1426	647
24"	600	33	838	19 1/2	495	21 1/2	546	5 5/8	143	2729	1238

## ASME CLASS 1500

Size		A		B		C		D		Weight	
in	mm	in	mm	in	mm	in	mm	in	mm	lbs	kg
2"	50	5 5/8	143	2 3/4	70	1 11/16	43	-	-	14	6
2 1/2"	65	6 1/2	165	3 1/4	83	2 1/8	54	1/16	2	16	7
3"	80	6 7/8	175	3 1/4	83	2 5/8	67	5/16	8	25	11
4"	100	8 1/4	210	4	102	3 7/16	87	9/16	14	43	20
5"	125	10	254	-	-	4 5/16	110	-	-	-	-
6"	150	11 1/8	283	6 1/4	159	5 3/16	132	1 1/16	27	110	50
8"	200	13 7/8	352	8 1/8	206	6 13/16	173	1 13/32	36	219	99
10"	250	17 1/8	435	9 3/4	248	8 1/2	216	1 11/16	43	397	180
12"	300	20 1/2	521	12	305	10 1/8	257	2 1/4	57	725	329
14"	350	22 3/4	578	14	356	11 1/2	292	2	51	948	430
16"	400	25 1/4	641	15 1/8	384	12 13/16	325	2 5/8	67	1380	627
18"	450	27 3/4	705	18 7/16	468	13 3/4	349	2 11/16	68	1900	863

\*Approximate weights and dimensions—Apply for certified drawings. Dimensions available with DIN, JIS, AS and ISO. Sizes above 24" per ASME B16.47 Series A. Series B available if required.

## PRESSURE DROP CALCULATIONS FOR GAS

Pressure drop for gas media across Champion Valves Wafer Check (in horizontal installation) can be determined using the following equation and Cv and Cracking Pressure shown for each valve size. Additional equations may be necessary in order to calculate the pressure drop.

### AMERICAN STANDARD (Horizontal Installation)

$$\Delta P = \frac{GT}{P} \left( \frac{Q}{1360 C_v} \right)^2 + P_c$$

Where:

- Cv = Flow Coefficient
- G = Specific Gravity of Gas
- P = Inlet Pressure, in psia (psig + 14.7)
- ΔP = Pressure Drop Across Valve, in psi
- Pc = Cracking Pressure
- Q = Gas Flow Rate, in SCFH
- T = Temperature, Absolute (°F + 460)

$$SCFH = ACFH \left( \frac{P}{14.7} \right) \left( \frac{520}{T} \right)$$

Where:

- ACFH = Actual Cubic Feet per Hour
- SCFH = Standard Cubic Feet per Hour

**NOTE:** Contact Champion Valves, Inc. for Vertical Installation



## PRESSURE DROP CHART

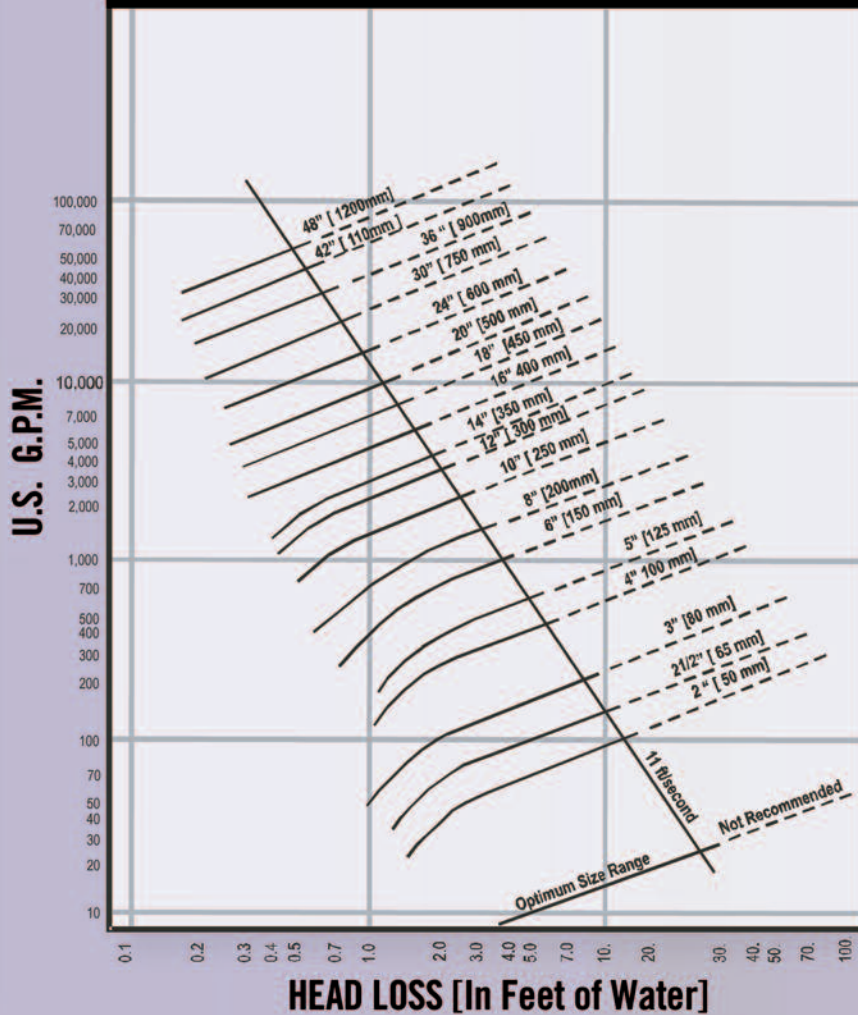

## C<sub>v</sub> & CRACKING PRESSURE

Size	C <sub>v</sub>	Pressure
2"	48	0.220
2.5"	77	0.189
3"	135	0.198
4"	270	0.184
5"	450	0.200
6"	720	0.218
8"	1400	0.162
10"	2600	0.230
12"	3850	0.241
14"	5000	0.230
16"	7250	0.210
18"	10,000	0.138
20"	12,400	0.128
24"	20,400	0.098
30"	38,000	0.099
36"	60,000	0.095
42"	89,000	0.090
48"	124,000	0.088

*Application specific spring torques are available.*

**PRESSURE DROP CHART.** This chart is based on flow of clean water at ambient temperature. Consult our engineering department for pressure drop information for steam, gases or viscous fluids. Consult factory for pressure drop of sizes larger than 48 inches.

### GOOD PIPING PRACTICE

recommends placement of check valves a distance equal to 5 pipe diameters from any turbulence producing device such as elbows, pumps, etc.

### RECOMMENDED FLOW RATE RANGES

*(Horizontal Installation)*

Media	Flow Rate
Liquid	3 to 11 feet/second 0.91 to 3.35 m/second
Gas	20 to 250 feet/second 6.1 to 76.2 m/second

EXCEPTIONAL QUALITY, SERVICE & RELIABILITY



CHAMPION VALVES INC.

P.O. Box 12901 · WILMINGTON, NC 28405 USA  
PH: 910.794.5547 · FAX: 910.794.5581 · E-MAIL: SALES@WAFERCHECK.COM

VISIT OUR WEBSITE AT: [WWW.WAFERCHECK.COM](http://WWW.WAFERCHECK.COM)

REPRESENTED BY:



## 150# Y-PATTERN SWING CHECK VALVE FEDERAL SPECIFICATION

**Features:**

- 300 WOG
- 150 PSI Saturated Steam
- Resilient Disc
- NPT Ends
  - Fig. 1241 - Sizes 1/2" to 3"
- Solder Ends
  - Fig. 1242 - Sizes 1/2" to 3"
- Conforms to MSS SP-80
- Body Markings Comply with MSS SP-25
- NPT Ends Comply with ANSI/ASME B1.20.1
- Solder Ends Comply with ANSI B16.18

Note: Before installing solder end valves, be sure the solder or brazing alloy melting point is sufficient to withstand the line pressure and temperature and is compatible with the media through the valve.



**Cv & Weights (lbs.)**

Size	Cv	1241	1242
1/2	4.8	0.60	0.56
3/4	14.3	0.91	0.80
1	24	1.35	1.30
1-1/4	43	2.18	1.95
1-1/2	60	3.06	2.70
2	102	4.57	4.45
2-1/2	150	7.70	7.68
3	238	11.00	9.15

**Figure Number Matrix**

FNW 1 2 4 1 Size		
END TYPE	SIZE CODE	
1 = NPT Ends	1/2 = D	1-1/2 = J
2 = Solder Ends	3/4 = F	2 = K
	1 = G	2-1/2 = L
	1-1/4 = H	3 = M

## 150# Y-PATTERN SWING CHECK VALVE FEDERAL SPECIFICATION

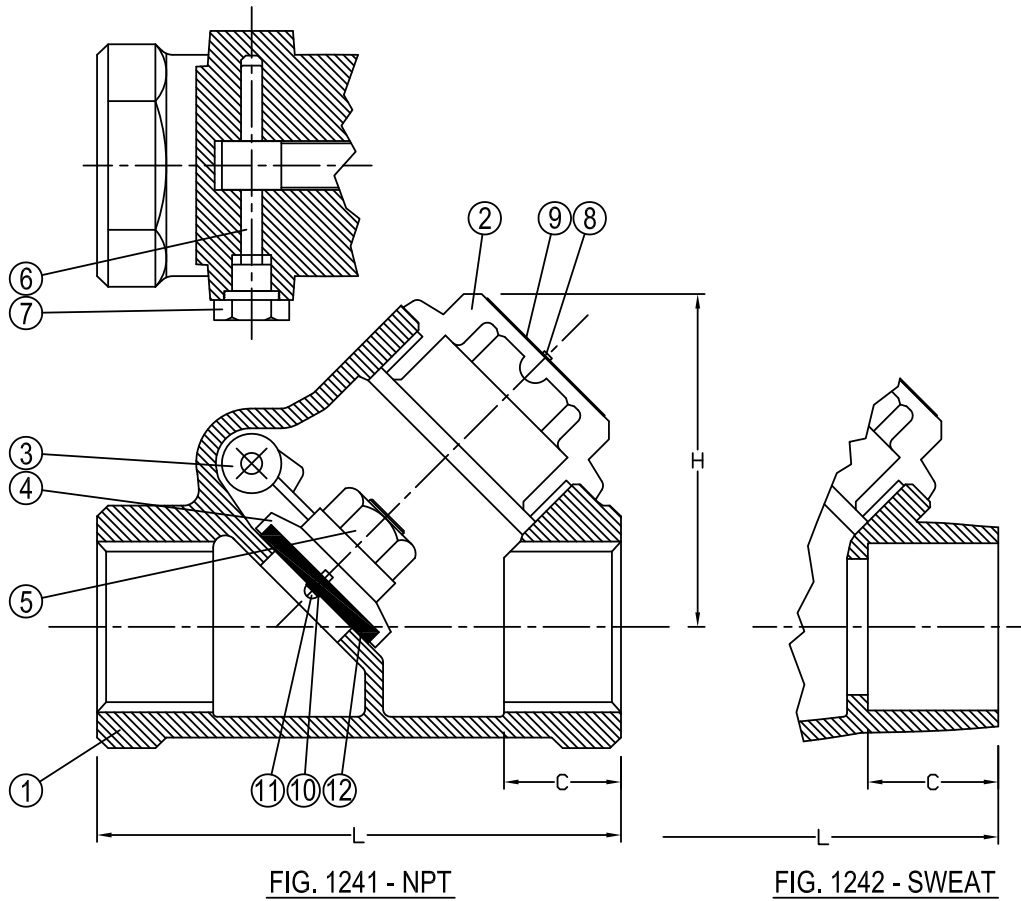

FIG. 1241 - NPT

FIG. 1242 - SWEAT

### Dimensions (inches)

SIZE	L		C		H	
	1241	1242	1241	1242	1241	1241
1/2	2.36	2.60	0.54	0.50	1.77	1.77
3/4	2.76	3.39	0.57	0.75	1.97	1.97
1	3.40	4.09	0.70	0.91	2.28	2.28
1-1/4	3.78	4.72	0.71	0.97	2.67	2.67
1-1/2	4.57	5.39	0.75	1.09	2.95	2.95
2	5.35	6.69	0.79	1.34	3.70	3.70
2-1/2	6.72	7.64	1.14	1.47	4.65	4.55
3	7.55	8.74	1.18	1.66	5.47	5.37

### Standard Materials

Ref. No.	Description	Material
1	Body	BRONZE ASTM B62 C83600
2	Cap	BRONZE ASTM B62 C83600
3	Hanger	BRONZE ASTM B62 C83600
4	Disc Holder	BRONZE ASTM B62 C83600
5	Hanger Nut	BRASS ASTM B16 C36000
6	Hanger Pin	BRASS ASTM B16 C36000
7	Side Plug	BRASS ASTM B16 C36000
8	Rivet	MILD STEEL
9	Name Plate	COMMERCIAL ALUMINUM
10	Washer	BRASS ASTM B16 C36000
11	Screw	BRASS ASTM B16 C36000
12	Disc	TEFLON (PTFE)

DOC: FNW1241-124206 Ver. 1/2012

© 2012 - FNW. All rights reserved.

The FNW logo is a trademark of Ferguson Enterprises, Inc., PL Sourcing, PO Box 2778, Newport News, VA 23609

The contents of this publication are presented for information purposes only, and while effort has been made to ensure their accuracy, they are not to be construed as warranties or guarantees, expressed or implied, regarding the products or services described herein or their use or applicability. All sales are governed by our terms and conditions, which are available on request. We reserve the right to modify or improve the designs or specifications of our products at any time without notice. Always verify that you have the most recent product specifications or other documentation prior to the installation of these products.





**API 600 WALL SWING CHECK VALVES**  
 BOLTED BONNET, ASME CLASSES 150 TO 1500  
 CAST CARBON, STAINLESS STEEL OR ALLOY STEEL

**STANDARD MATERIALS (Other materials available)**

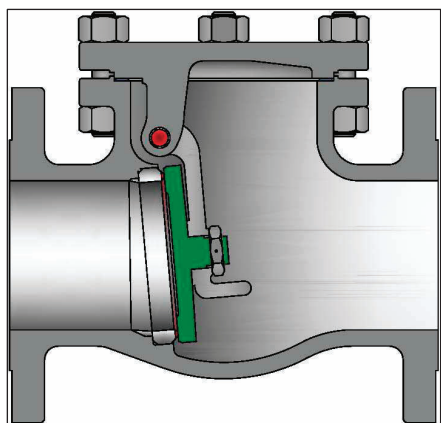

Class	Figure Number
150	1561
300	3061
600	6061
900	9061
1500	1361

PART	MATERIALS			
	A216 Gr. WCB	A217 Gr. WC6	A217 Gr. WC9	A351 Gr. CF8M (2)
Body	A216 Gr. WCB	A217 Gr. WC6	A217 Gr. WC9	A351 Gr. CF8M (2)
Cap	A216 Gr. WCB	A217 Gr. WC6	A217 Gr. WC9	A351 Gr. CF8M
Disc	A105+13% CR Faced or WCB+13% CR Faced	WC6+Stellite 6 Faced	WC9+Stellite 6 Faced	A351 Gr. CF8M
Seat Ring	Carbon Steel + Stellite 6 Faced	A182 F11 + Stellite 6 Faced	A182 F22 + Stellite 6 Faced	316 SST
Gasket	Class 150: Corrugated SST Encapsulated w/ Graphite Class 300 to 600: Spiral Wound SST with Graphite Class 900-1500: RTJ			Class 150: PTFE Class 300-600: Spiral Wound SST with Graphite
Carrier	A216 Gr. WCB	A217 Gr. WC6	A217 Gr. WC9	A351 Gr. CF8M
Carrier Pin	SST 410			316 SST
Disc Nut	Series 300 SST			A193 Gr. B8M
Disc Carrier Hanger (1)	A216 Gr. WCB	A217 Gr. WC6	A217 Gr. WC9	A351 Gr. CF8M
Disc Carrier Hanger Bolts (1)	A193 Gr. B7	A193 Gr. B16		A193 Gr. B8M
Body / Cap Stud	A193 Gr. B7	A193 Gr. B16		A193 Gr. B8
Body / Cap Nut	A194 Gr. 2H	A194 Gr. 7		A194 Gr.8
Identification Plate	Series 300 SST			

(1) 8" Valve size and up. (2) CF3M used for weld end valves.

**DESIGN FEATURES:**

- **Standard trim** is API trim 8 for carbon steel valves, API trim 5 for chrome alloy valves, and API trim 10 for CF8M (T316) valves for optimal performance under normal conditions. Other trim materials available on request.
- **Seat faces** lapped for smooth finish and superior sealing.
- **Wall thickness** per heavy wall API 600 requirements.
- **Swivel disc** for improved seat alignment and longer life.
- **Each** valve is shell and seat pressure tested per industry standard API 598.
- **Check** valves are suitable for service in horizontal line with cap vertical or in a vertical line with flow upward.
- **Carrier Pin** is confined within the body wall and is not accessible from the exterior, thus no side body penetrations, eliminating a common leak path, on classes 150 through 600.
- **End Flanges** have the following raised faces per ASME B16.5:  
 Classes 150-300: 1/16" (2mm).  
 Classes 600-1500: 1/4" (7mm).

**NOTE: See page 52 for flow, safety and maintenance information.**

**Design Specifications**

Item	Applicable Specification
Wall thickness	API 600
Pressure - temperature ratings	ASME B16.34
General valve design	B16.34
End to End dimensions	ASME B16.10
Flange design	ASME B16.5
Butt Weld design	ASME B16.25
Materials	ASTM

- **Each** valve has a unique certification number that is traceable to the valve certification sheet which includes MTR data, pressure test, inspection result and certificate of conformance.
- **Other** available options as follows:  
 -Alternate valve materials such as chrome and stainless steel alloys  
 -Alternate trim materials  
 -Drain and other auxiliary connections  
 -NACE service  
 -Special cleaning for applications such as oxygen or chlorine  
 -Other options available as specified

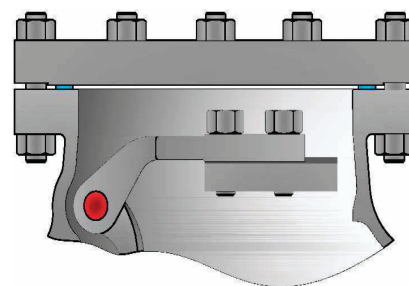

Valve design for valve sizes 8" and above all pressure classes.

**SWING CHECK VALVE DIMENSIONS (CLASS 150–1500).**

SIZE	ASME 150				ASME 300				ASME 600			
	A	B	C	D	A	B	C	D	A	B	C	D
in	WE/FE				in				WE/FE			
2	8.00	4.9	4.6	2.00	10.50	5.0	4.6	2.00	11.50	6.9	7.3	2.00
50	203	126	118	51	267	126	118	51	292	176	185	51
2 ½	8.50	5.6	6.8	2.50	11.50	5.6	6.8	2.50	13.00	7.4	7.9	2.50
65	216	142	172	64	292	142	172	64	330	189	200	64
3	9.50	5.9	7.7	3.00	12.50	5.9	7.7	3.00	14.00	8.3	8.5	3.00
80	241	149	195	76	318	149	195	76	356	212	215	76
4	11.50	6.5	9.1	4.00	14.00	6.5	9.1	4.00	17.00	10.3	10.6	4.00
100	292	166	230	101	356	166	230	102	432	262	270	102
6	14.00	8.2	10.8	6.00	17.50	8.6	11.8	6.00	22.00	14.0	13.5	6.00
150	356	208	273	152	444	219	298	152	559	356	342	152
8	19.50	11.9	15.1	8.00	21.00	13.3	15.6	8.00	26.00	18.5	17.1	7.87
200	495	302	384	203	533	338	397	203	660	469	435	200
10	24.50	14.2	17.8	10.00	24.50	15.3	18.5	10.00	31.00	21.2	20.1	9.75
250	622	360	450	254	622	389	470	254	787	539	510	248
12	27.50	15.7	21.6	12.00	28.00	17.9	22.3	12.00	33.00	23.4	22.6	11.75
300	698	399	549	305	711	455	565	305	838	594	575	298
14	31.00	22.2	20.9	13.25	33.00	23.4	21.7	13.25	35.00	25.4	23.5	12.87
350	787	565	532	337	838	595	550	337	889	645	598	327
16	34.00	23.6	25.3	15.25	34.00	24.9	27.4	15.25	39.00	28.6	27.6	14.75
400	864	599	642	387	864	632	695	387	991	727	700	375
18	38.50	27.9	29.6	17.25	38.50	28.5	30.4	17.00	43.00	32.5	29.1	16.50
450	978	709	752	438	978	723	772	432	1092	826	740	419
20	38.50	26.7	27.0	19.25	40.00	24.9	29.1	19.00	47.00	31.6	32.3	18.25
500	978	679	685	489	1016	632	738	483	1194	802	820	464
24	51.00	33.5	36.0	23.25	53.00	34.8	37.6	23.00	55.00	40.2	39.4	22.00
600	1295	852	915	591	1346	884	955	584	1397	1020	1000	559

SIZE	ASME 900				ASME 1500			
	A	B	C	D	A	B	C	D
in	WE/FE				in			
2	14.50	9.6	8.9	1.87	14.50	9.6	8.9	1.87
50	368	244	226	47	368	244	226	47
2 ½	16.50	10.2	9.2	2.25	16.50	10.3	9.2	2.25
65	419	260	235	57	419	260	235	57
3	15.00	10.6	10.2	2.87	18.50	12.6	10.4	2.75
80	381	268	258	73	470	319	265	70
4	18.00	12.9	11.6	3.87	21.50	15.8	15.4	3.62
100	457	328	295	98	546	400	390	92
6	24.00	17	15.8	5.75	27.75	18.4	17.2	5.37
150	610	433	400	146	705	468	435	136
8	29.00	23.6	17.5	7.50	32.75	23.8	20.3	7.00
200	737	600	445	191	832	604	515	178
10	33.00	24.4	22.6	9.37	39.00	25.6	22.4	8.75
250	838	620	575	238	991	650	570	222

**B** = Center to top

**WE** = Butt Weld ends

**FE** = Flanged ends

**ADDITIONAL SIZES, MATERIALS AND CLASSES AVAILABLE UPON REQUEST.**

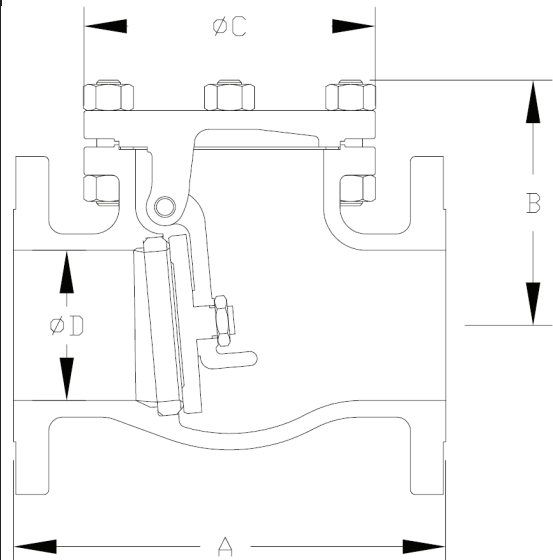

SIZE	ASME 150						ASME 300						ASME 600								
	in	in	WT	lb	WT	lb	C <sub>v</sub>	F	in	WT	lb	WT	lb	C <sub>v</sub>	F	in	WT	lb	WT	lb	C <sub>v</sub>
mm	F	mm	FE	kg	WE	kg		mm	FE	kg	WE	kg	mm		FE	kg	WE	kg			
2	6.0		27		23		75	6.0		34		29		75	8.0		62		49		75
50	155		12		10			155		15		13			205		28		22		
2 ½	7.0		40		35		120	7.0		53		45		120	8.5		79		62		120
65	175		18		16			175		24		21			220		36		28		
3	7.5		53		41		170	7.5		68		58		170	10.0		110		79		170
80	190		24		19			190		31		27			250		50		36		
4	8.5		79		57		320	8.5		110		94		320	12.5		215		168		320
100	215		36		26			220		50		42			315		98		76		
6	11.0		132		113		760	11.5		212		182		760	17.0		439		335		760
150	285		60		51			295		96		82			435		199		152		
8	16.0		337		293		1400	17.5		507		437		1400	22.5		811		633		1300
200	405		153		133			440		230		198			570		368		287		
10	19.0		567		483		2200	20.5		858		728		2200	26.0		1343		1047		2100
250	490		257		219			515		389		330			665		609		475		
12	22.0		873		758		3300	24.0		1160		1077		3300	29.5		1702		1363		3100
300	555		396		344			610		526		488			745		772		618		
14	29.0		979		834		4000	30.0		1411		1241		4000	32.0		1958		1585		3700
350	735		444		378			765		640		563			810		888		719		
16	31.0		1438		1250		5200	32.5		1764		1550		5200	36.0		2994		2364		4900
400	795		652		567			825		800		703			915		1358		1072		
18	36.5		1927		1656		7000	37.0		2578		2192		6800	35.5		3449		2932		6400
450	930		874		751			940		1169		994			900		1564		1330		
20	36.5		1771		1522		8700	34.5		2913		2505		8500	36.5		4792		4121		7800
500	925		803		690			875		1321		1136			925		2174		1869		
24	45.0		3559		3062		13000	46.5		5204		4428		12000	45.0		7608		6467		11000
600	1150		1614		1388			1175		2360		2008			1145		3451		2933		

SIZE	ASME 900						ASME 1500								
	in	F	in	WT	lb	WT	lb	C <sub>v</sub>	F	in	WT	lb	WT	lb	C <sub>v</sub>
mm	mm	FE	kg	WE	kg	mm	FE		kg	WE	kg	mm	FE	kg	
2	10.5		165		132		65		10.5		165		132		65
50	270		75		60				270		75		60		
2 ½	11.5		265		183		100		11.5		265		183		100
65	290		120		83				290		120		83		
3	12.0		209		154		160		14.0		375		271		150
80	305		95		70				355		170		123		
4	15.0		375		271		300		17.5		963		463		260
100	380		170		123				445		437		210		
6	20.0		716		518		700		21.0		1235		1036		600
150	505		325		235				535		560		470		
8	27.5		1257		877		1200		27.5		2271		1907		1100
200	700		570		398				695		1030		865		
10	29.0		1808		1437		1900		30.0		3483		2888		1700
250	740		820		652				760		1580		1310		

F = Dismantling dimension

WE = Butt Weld ends

FE = Flanged ends

WT = Weight

C<sub>v</sub> = Flow coefficient

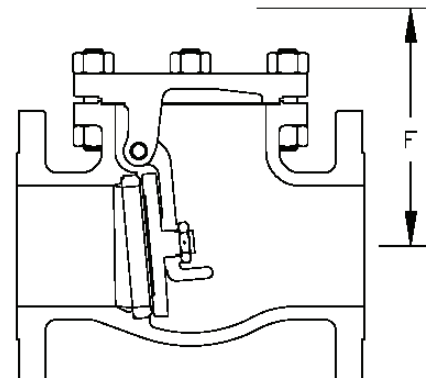

## Forged Check Valves

### Class 2500/2680 Forged Check Valve Full Port

Welded Bonnet  
 "Y" Pattern  
 Horizontal or Vertical Upward Flow  
 Spring Control Hard Faced Piston Check  
 Integral Hard Faced Seat  
 ASME B16.34 LTD Pressure Class

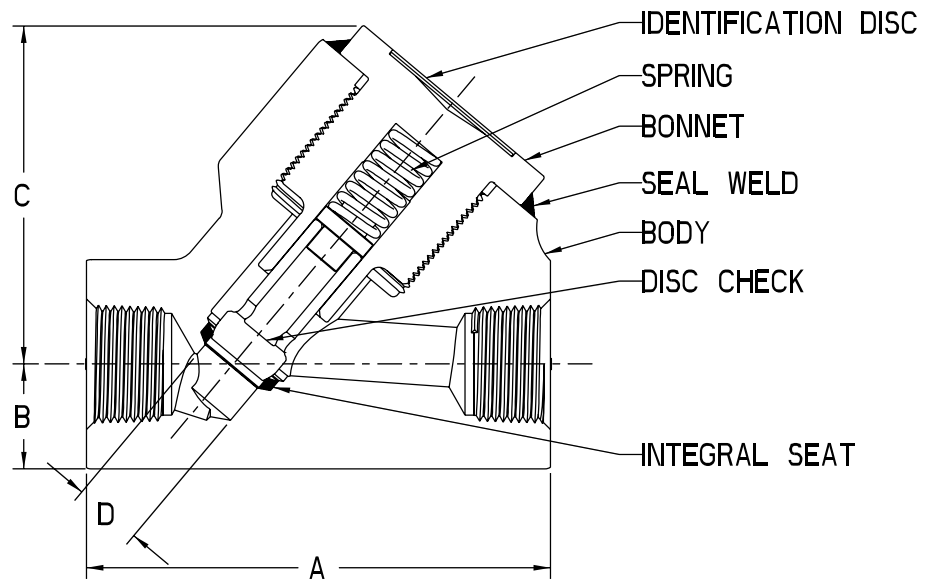

CONNECTION	SERIES	BODY/BONNET	TRIM	SEAT	SPRING	RATING		CLASS
Threaded	2610	A105	13% Cr	HF	302 SS	6250 PSI @ 100 F	430.9 @ 38 C	2500 LTD
	2611	F11 Cl.2						
	2622	F22 Cl.3						
	2691	F91						
Socket Weld	SW2610	A105	13% Cr	HF	302 SS	6700 PSI @ 100 F	461.9 @ 38 C	2680 LTD
	SW2611	F11 Cl.2						
	SW2622	F22 Cl.3						
	SW2691	F91						

### Dimensions

SIZE			A	B	C	D	WEIGHT	Cv
-04	NPS	½	4.00	0.81	2.71	0.50	4.3	-
	DN	15	102	21	69	13	2.0	
-05	NPS	¾	5.12	1.16	3.74	0.75	9.9	-
	DN	20	130	29	95	19	4.5	
-06	NPS	1	5.12	1.16	3.74	0.75	9.6	-
	DN	25	130	29	95	19	4.4	
-08	NPS	1½	8.25	2.06	5.37	1.53	38.9	-
	DN	40	210	52	136	39	17.6	
-09	NPS	2	8.25	2.06	5.37	1.53	36.9	-
	DN	50	210	52	136	39	16.7	



# Forged Check Valves

## Class 2500/2680 Forged Check Valve Full Port

Screw Bonnet  
 "Y" Pattern  
 Horizontal or Vertical Upward Flow  
 Spring Control Hard Faced Piston Check  
 Integral Hard Faced Seat  
 ASME B16.34 LTD Pressure Class

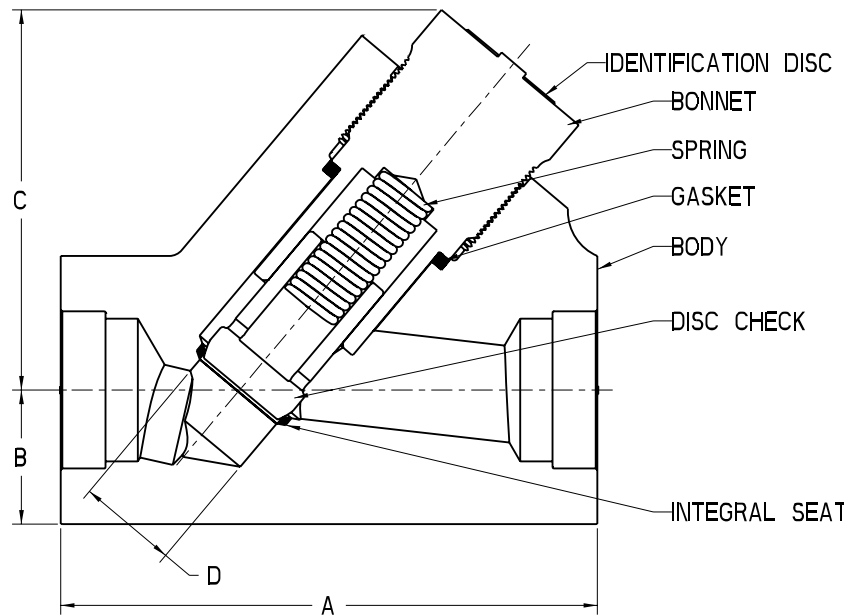

CONNECTION	SERIES	BODY/BONNET	TRIM	SEAT	SPRING	RATING		CLASS
Threaded	R2610	A105	13% Cr	HF	302 SS	6250 PSI @ 100 F	430.9 @ 38 C	2500 LTD
	R2611	F11 Cl.2						
	R2622	F22 Cl.3						
	R2691	F91						
Socket Weld	SWR2610	A105	13% Cr	HF	302 SS	6700 PSI @ 100 F	461.9 @ 38 C	2680 LTD
	SWR2611	F11 Cl.2						
	SWR2622	F22 Cl.3						
	SWR2691	F91						

### Dimensions

SIZE			A	B	C	D	WEIGHT	Cv
-04	NPS	½	4.00	0.81	3.20	0.50	4.6	-
	DN	15	102	21	81	13	2.1	
-05	NPS	¾	5.12	1.16	4.23	0.75	10.6	-
	DN	20	130	29	107	19	4.8	
-06	NPS	1	5.12	1.16	4.23	0.75	10.3	-
	DN	25	130	29	107	19	4.7	
-08	NPS	1½	8.25	2.06	5.84	1.53	40.0	-
	DN	40	210	52	148	39	18.1	
-09	NPS	2	8.25	2.06	5.48	1.53	38.0	-
	DN	50	210	52	148	39	17.2	

# 074 & 075 Poppet Check Valves

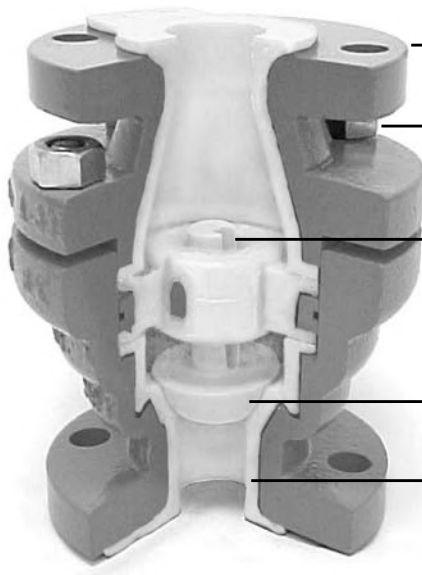

Figure 074

Ductile iron or cast steel bodies available.

B7 bolting resists chloride stress-cracking.

Keyway prevents poppet rotation.

Poppet covering matches body liner in 4" thru 8" sizes (solid PTFE poppet in 1" thru 3" sizes). Steel insert in 4" thru 8" valve poppet.

Choice of 3 liner materials (PP, PVDF, PFA) for handling a wide range of fluids.

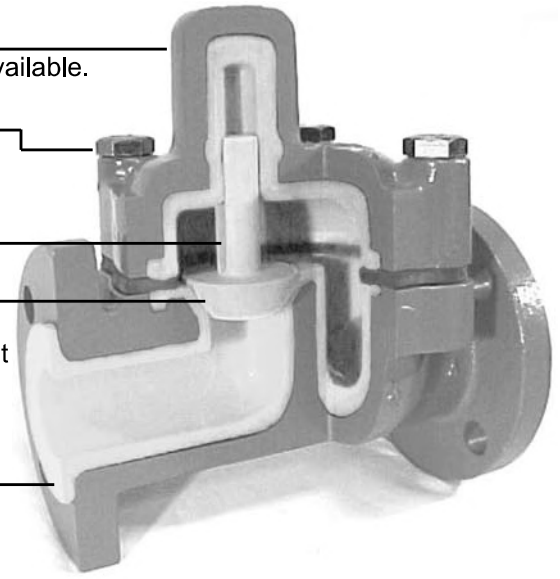

Figure 075

**Tufline Plastic-Lined Poppet Check Valves** handle various corrosive media at temperatures from -20°F to 300°F (-28°C to 149°C) by combining the best properties of two different materials of construction.

On the outside, a metal body provides strength, shock resistance, ease of installation, and a high pressure handling capability.

On the inside, a plastic lining offers corrosion resistance that stainless steel and high alloy metal valves can't match. The thick plastic lining also prevents contamination of high purity fluids.

## Poppet-type check valves.

Horizontal and vertical check valves are plastic lined for handling corrosives and high-purity fluids. They are extremely effective in preventing back-pressure or backflow, featuring a low 0.5 psi (0.03 bar) cracking pressure differential, and are capable of handling pressures to 275 psi (19 bar).

Since Tufline Check Valves have only one moving part, they are less likely to need maintenance. Because every surface in contact with the fluid is made of, or covered with, a thick layer of plastic, corrosion and contamination are virtually eliminated. They also have full pipe diameter ports and provide minimal obstruction in the flow path. The poppet-type design eliminates problems that occur in some check valves with pockets that can trap fluid.

## Pressure/temperature ratings

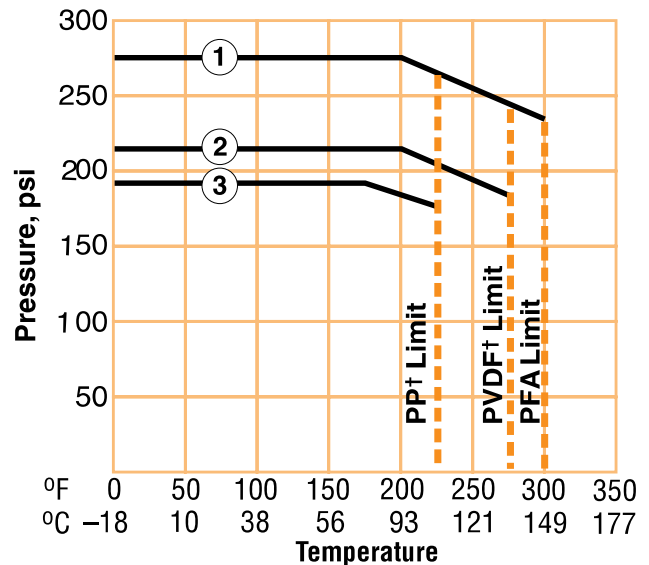

Class 150 Cast Steel 1" - 4" Valves

□ Class 150 Cast Steel 6" & 8" Valves

□ Class 150 Ductile Iron

† Maximum allowable temperature of liner/gasket may be lower based on the aggressiveness of the fluid being handled. Contact Xomox for further details.

## Available size, body material, and lining combinations for both 074 and 075 valves

Size (in.)	1		1½		2		2½		3		4		6		8	
Body Material	DI	CS	DI	CS	DI	CS	DI	CS	DI	CS	DI	CS	DI	CS	DI	CS
PP	●	●	●	●	●	●	●	●	●	●	●	●	●	●	●	●
PVDF		●		●		●				●		●		●		*
PFA		●		●		●				●		●				

\*Vertical Check Valve (074) only



### Poppets.

Valves 1” through 3” sizes feature a solid PTFE poppet. Larger sizes use a steel reinforced poppet molded of the same material as the valve liner.

### Cv Factors

Size	Horizontal	Vertical
1	5	8
1½	22	60
2	30	130
2½	N/A	N/A
3	80	320
4	150	500
6	450	1100
8	800	1500

## Body bolting torques.

To ensure optimum performance in the presence of thermal cycling, it is essential that the body nuts be torqued to the values shown in the table below.

Torquing should only be done on the system in the ambient, cooled state, never at elevated temperature. Otherwise, excessive force could be applied to the plastic faces. Xomox recommends retorquing body bolts immediately before installation of the valve.

### Body bolt torque values (ft-lbs)

Size	Horizontal		Vertical
	Elastometric gaskets	PTFE gaskets	
1	30	30	35
1½	30	30	35
2	30	40	45
2½	30	N/A	60
3	55	120	60
4	40	60	50
6	65	110	75
8	80	125	120

## Check valve dimensions & weights (All dimensions in inches)

		1	1½	2	2½	3	4	6	8
A	Horizontal Face To Face	7.00	7.63	8.63	8.88	10.75	14.50	18.50	23.13
A	Vertical Face To Face	6.38	7.13	8.13	8.50	9.75	12.00	14.50	17.13
B	Horizontal Center To Top	4.38	5.38	6.50	7.38	8.63	11.00	15.25	18.44
B	Vertical Center To Top	5.38	5.63	6.75	7.00	8.38	9.75	12.75	16.20
C	Flange Thickness	.44	.56	.63	.063	.75	.94	1.00	1.13
D	Plastic ID (PP, PVDF)	.69	1.25	1.63	2.09	2.69	3.50	5.56	7.25
D	Plastic ID (PFA)	.69	1.31	1.75	N/A	2.81	3.69	N/A	N/A
N	No. Of Bolt Holes	4	4	4	4	4	8	8	8
O	Size Of Bolt Holes	.63	.63	.75	.75	.75	.75	.88	.88
P	Bolt Circle Diameter	3.20	3.88	4.75	5.50	6.00	7.50	9.50	11.75
G	Flange Diameter	4.20	5.00	6.00	7.00	7.50	9.00	11.00	13.50
J	Face Diameter	1.88	2.69	3.44	3.94	4.63	5.94	8.00	10.06
K	Horizontal Approx. Weight, lbs.	15	19	31	37	56	92	200	330
K	Vertical Approx. Weight, lbs.	16	19	31	38	52	88	142	225

NA=Not Available

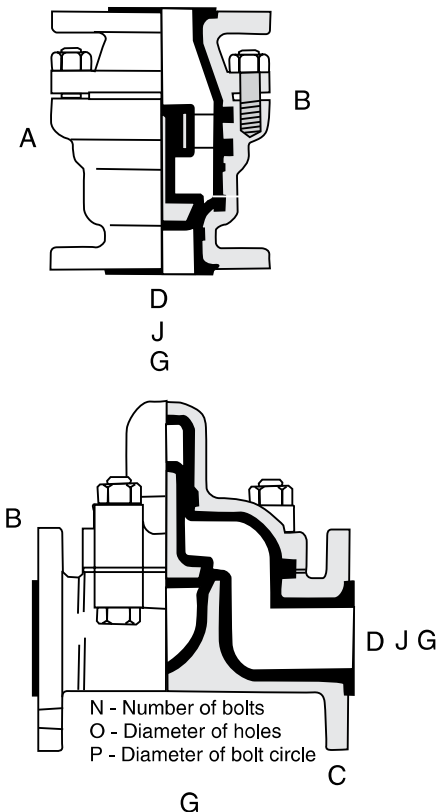

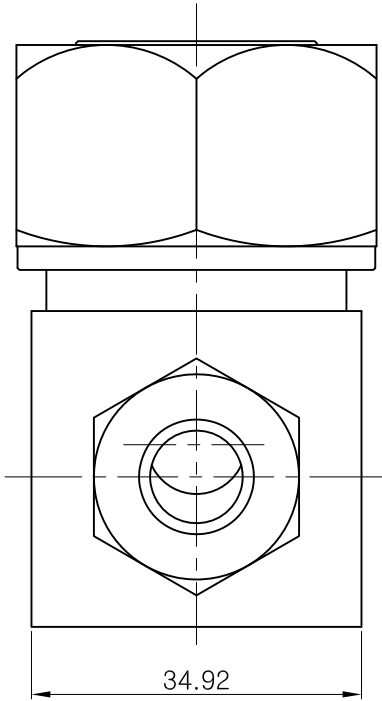
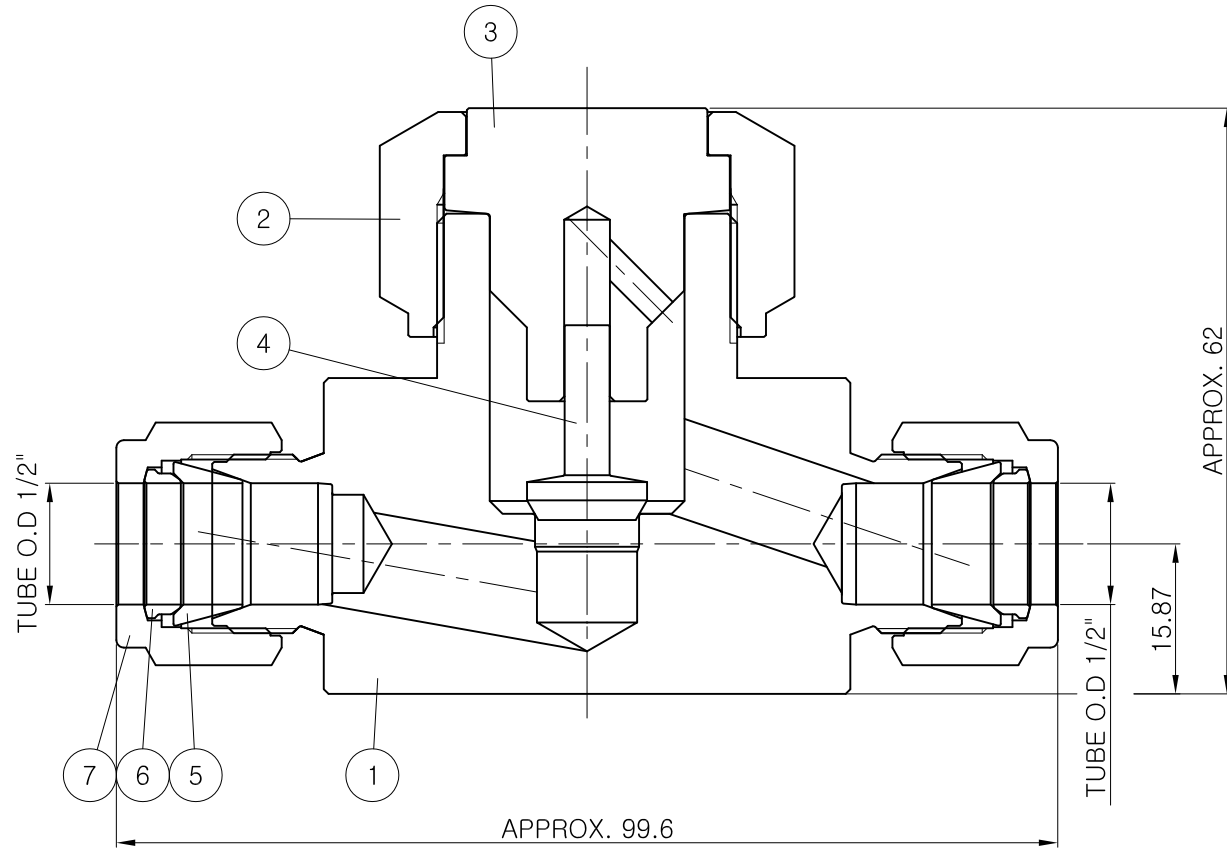

7	NUT	ASTM A276 TYPE316	2
6	BACK FERRULE	ASTM A479 TYPE316	2
* 5	FRONT FERRULE	ASTM A479 TYPE316	2
* 4	POPET	ASTM A564 TYPE630	1
* 3	BONNET	ASTM A276 TYPE316	1
2	BONNET NUT	ASTM A276 TYPE316	1
* 1	BODY	ASTM A276 TYPE316	1
NO.	DESCRIPTION	MATERIAL	Q'TY

- \* SPECIFICATION
- DESIGN PRESSURE : 6,000 psig@100°F (413 bar@38°C)
  - TEMPERATURE RANGE : UP TO 900°F (482°C)
  - ORIFICE :  $\phi 11.1\text{mm}$
  - Cv : 2.2
  - UNIT : mm
  - DIMENSIONS ARE FOR REFERENCE ONLY AND ARE SUBJECT TO CHANGE.
  - DIMENSIONS ARE SHOWN WITH DK-LOK NUTS FINGER-TIGHT.
  - "\*" ARE WETTED PARTS.

APPROVED	<i>[Signature]</i>	TITLE VL36C SERIES LIFT CHECK VALVE DK-LOK TUBE O.D 1/2"
REVIEWED	<i>J.M. Seo</i>	
DESIGNED	<i>Y.J. Hwang</i>	
SCALE	1.25 : 1	
DATE	2016.12.26	
DWG. NO.	VL36C-D-8T-S	<b>IDK-LOK</b> Fittings & Valves

# GEMÜ 675

## Manually operated diaphragm valve



### Features

- Suitable for particulate and abrasive media
- Various lining materials are available for a wide range of media
- Optische Stellungsanzeige serienmäßig integriert

### Description

The GEMÜ 675 2/2-way diaphragm valve has a metal handwheel and is manually operated. An integral optical position indicator is standard.

### Technical specifications

- **Media temperature:** 14 to 212 °F
  - **Ambient temperature:** 32 to 140 °F
  - **Operating pressure :** 0 to 150 psi
  - **Nominal sizes:** 1/2" (DN 15) to 6" (DN 150)
  - **Body configurations:** 2/2-way body
  - **Connection standards:** ANSI | BS | DIN | EN
  - **Body materials:** EN-GJL-250, cast iron material | EN-GJS-400-18-LT, SG iron material | EN-GJS-400-18-LT, SG iron material with hard rubber lining | EN-GJS-400-18-LT, SG iron material, PFA lined | EN-GJS-400-18-LT, SG iron material, PP lined | EN-GJS-500-7, ductile iron material, PFA lined | EN-GJS-500-7, ductile iron material, PP lined
  - **Body lining:** Hard rubber | PFA | PP
  - **Diaphragm materials:** CR | EPDM | FKM | NBR | PTFE/EPDM | PTFE/FKM | PTFE/PVDF/EPDM
  - **Conformities:** CRN | EAC | FDA | Reg. (EU) No. 10/2011 | Regulation (EC) No. 1935/2004 | TA Luft (German Clean Air Act)
- Technical data depends on the respective configuration



## Product description

### Construction

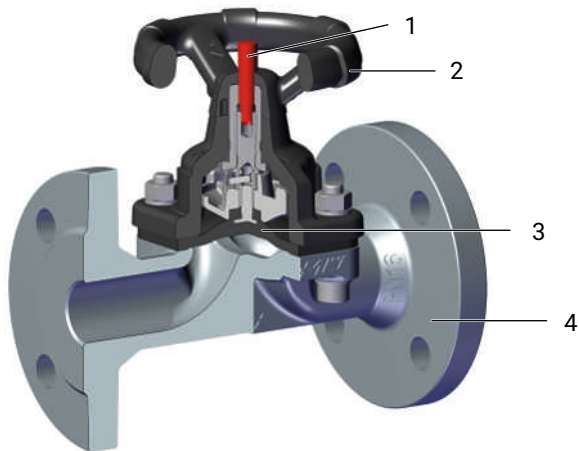

Item	Name	Materials
1	Optical position indicator	PP red
2	Actuator	Cast iron
3	Diaphragm	NBR FKM CR EPDM PTFE / EPDM (one-piece) PTFE / EPDM (two-piece) PTFE / FKM (two-piece) PTFE / PVDF / EPDM (three-piece)
4	Valve body	EN-GJL-250 (GG 25) EN-GJS-400-18-LT (GGG 40.3) EN-GJS-400-18-LT (GGG 40.3), PFA lined EN-GJS-400-18-LT (GGG 40.3), PP lined EN-GJS-400-18-LT (GGG 40.3), hard rubber lined EN-GJS-500-7 (GGG 50), PFA lined EN-GJS-500-7 (GGG 50), PP lined

## Availability

### Availability of valve bodies

#### Threaded connection, flange

MG	DN	Threaded connection	Flange																		
			Connection types code <sup>1)</sup>																		
			1, 31	8			38			39			51		53		56				
			Material code <sup>2)</sup>																		
		90	90	17	18	83	17	18 <sup>3)</sup>	83	90	17	18	83	17	81	91 <sup>3)</sup>	8	17	17	81	91 <sup>3)</sup>
25	15	X	X	X	X	X	-	-	-	X	X	X	X	-	-	-	X	-	-	-	-
	20	X	X	X	X	X	X	X	X	X	X	X	X	-	-	-	X	-	-	-	-
	25	X	X	X	X	X	X	X	X	X	X	X	X	-	X	X	X	-	-	X	X
40	32	X	X	X	X	X	-	-	-	X	X	X	X	-	-	-	-	-	-	-	-
	40	X	X	X	X	X	X	X	X	X	X	X	X	-	X	X	X	-	-	X	X
50	50	X	X	X	X	X	X	X	X	X	X	X	X	-	X	X	X	-	-	X	X
	65	-	X	-	-	-	-	-	-	X	-	-	-	-	-	-	-	-	-	-	-
65	65	-	-	X	X	X	X	X	X	-	X	X	X	-	-	-	X	-	-	-	-
80	80	-	X	X	X	X	X	X	X	X	X	X	X	-	X	X	X	-	-	X	X
100	100	-	X	X	X	X	X	X	X	X	X	X	X	-	X	X	X	-	-	X	X
	125	-	X	-	-	-	-	-	-	X	-	-	-	-	-	-	-	-	-	-	-
125	125	-	-	X	-	X	-	-	-	-	X	-	X	-	-	-	X	-	-	-	-
150	150	-	X	X	-	X	X	-	X	X	X	-	X	X	-	-	X	X	X	-	-

MG = diaphragm size

X = Standard

#### 1) Connection type

Code 1: Threaded socket DIN ISO 228

Code 8: Flange EN 1092, PN 16, form B, face-to-face dimension FTF EN 558 series 1, ISO 5752, basic series 1, length only for body configuration D

Code 31: NPT female thread

Code 38: Flange ANSI Class 150 RF, length only for body configuration D acc. to MSS SP-88

Code 39: Flange ANSI Class 125/150 RF, length only for body configuration D acc. to EN 558 series 1, ISO 5752, basic series 1

Code 51: Flange BS 10 Table E, face-to-face dimension FTF EN 558 series 7, ISO 5752, basic series 7, length only for body configuration D

Code 53: Flange EN 1092, PN 16, form A, face-to-face dimension FTF EN 558 series 7, ISO 5752, basic series 7, length only for body configuration D

Code 56: Flange ANSI Class 125/150 RF, face-to-face dimension FTF EN 558 series 7, ISO 5752, basic series 7, length only for body configuration D

#### 2) Valve body material

Code 8: EN-GJL-250 (GG 25)

Code 17: EN-GJS-400-18-LT (GGG 40.3), PFA lined

Code 18: EN-GJS-400-18-LT (GGG 40.3), PP lined

Code 81: EN-GJS-500-7 (GGG 50), PFA lined

Code 83: EN-GJS-400-18-LT (GGG 40.3), hard rubber lined

Code 90: EN-GJS-400-18-LT (GGG 40.3)

Code 91: EN-GJS-500-7 (GGG 50), PP lined

#### 3) on request

### Availability of actuator version

MG	DN	Actuator version
25	15 – 25	0
40	32 – 40	1
50	50 – 65	2

## Availability

MG	DN	Actuator version
65	65	3
80	80	4
100	100 – 125	5
125	125	6
150	150	7



## Order data

The order data provide an overview of standard configurations.

Please check the availability before ordering. Other configurations available on request.

## Order codes

1 Type	Code
Diaphragm valve, manually operated, metal handwheel, metal distance piece, optical position indicator	675

2 DN	Code
DN 15	15
DN 20	20
DN 25	25
DN 32	32
DN 40	40
DN 50	50
DN 65	65
DN 80	80
DN 100	100
DN 125	125
DN 150	150

3 Body configuration	Code
2/2-way body	D

4 Connection type	Code
Threaded socket DIN ISO 228	1
NPT female thread	31
<b>Flange</b>	
Flange EN 1092, PN 16, form B, face-to-face dimension FTF EN 558 series 1, ISO 5752, basic series 1, length only for body configuration D	8
Flange ANSI Class 150 RF, length only for body configuration D acc. to MSS SP-88	38
Flange ANSI Class 125/150 RF, length only for body configuration D acc. to EN 558 series 1, ISO 5752, basic series 1	39
Flange BS 10 Table E, face-to-face dimension FTF EN 558 series 7, ISO 5752, basic series 7, length only for body configuration D	51
Flange EN 1092, PN 16, form A, face-to-face dimension FTF EN 558 series 7, ISO 5752, basic series 7, length only for body configuration D	53
Flange ANSI Class 125/150 RF, face-to-face dimension FTF EN 558 series 7, ISO 5752, basic series 7, length only for body configuration D	56

5 Valve body material	Code
<b>Cast iron material</b>	
EN-GJL-250 (GG 25)	8

5 Valve body material	Code
<b>SG iron material</b>	
EN-GJS-400-18-LT (GGG 40.3), PFA lined	17
EN-GJS-400-18-LT (GGG 40.3), PP lined	18
EN-GJS-500-7 (GGG 50), PFA lined	81
EN-GJS-400-18-LT (GGG 40.3), hard rubber lined	83
EN-GJS-400-18-LT (GGG 40.3)	90
EN-GJS-500-7 (GGG 50), PP lined	91

6 Diaphragm material	Code
<b>Elastomer</b>	
NBR	2
FKM	4
CR	8
EPDM	29
<b>PTFE</b>	
PTFE/EPDM one-piece	54
PTFE/EPDM two-piece	5M
PTFE/FKM two-piece	5T
PTFE/PVDF/EPDM three-piece	71
<b>Note:</b> The PTFE/PVDF/EPDM diaphragm (code 71) can only be combined with PFA lined valve bodies.	

7 Control function	Code
Manually operated	0
Manually operated, with lockable handwheel	L
Manually operated with lockable handwheel, (without proprietary padlock)	B

Order data

8 Actuator version	Code
<b>Clamp</b>	
Actuator size 0	0
<b>Clamp</b>	
Actuator size 1	1
<b>Clamp</b>	
Actuator size 2	2
<b>Clamp</b>	
Actuator size 3	3

8 Actuator version	Code
<b>Clamp</b>	
Actuator size 4	4
<b>Clamp</b>	
Actuator size 5	5
<b>Clamp</b>	
Actuator size 6	6
<b>Clamp</b>	
Actuator size 7	7

**Order example**

Order option	Code	Description
1 Type	675	Diaphragm valve, manually operated, metal handwheel, metal distance piece, optical position indicator
2 DN	50	DN 50
3 Body configuration	D	2/2-way body
4 Connection type	8	Flange EN 1092, PN 16, form B, face-to-face dimension FTF EN 558 series 1, ISO 5752, basic series 1, length only for body configuration D
5 Valve body material	90	EN-GJS-400-18-LT (GGG 40.3)
6 Diaphragm material	29	EPDM
7 Control function	0	Manually operated
8 Actuator version	2	Actuator size 2

## Technical data

### Medium

**Working medium:** Corrosive, inert, gaseous and liquid media which have no negative impact on the physical and chemical properties of the body and diaphragm material.

### Temperature

**Media temperature:**

NBR (code 2)	14 – 212 °F
FKM (code 4)	14 – 194 °F
CR (code 8)	14 – 212 °F
EPDM (code 29)	14 – 212 °F
PTFE / EPDM (code 54)	14 – 212 °F
PTFE / EPDM (code 5M)	14 – 212 °F
PTFE / FKM (code 5T)	14 – 212 °F
PTFE / PVDF / EPDM (code 71)	14 – 212 °F

**Ambient temperature:** 32 – 140 °F

**Storage temperature:** 32 – 104 °F

### Pressure

**Operating pressure:**

MG	DN	EPDM	PTFE
25	15 - 25	0 - 150	0 - 90
40	32 - 40	0 - 150	0 - 90
50	50 - 65	0 - 150	0 - 90
65	65	0 - 150	0 - 90
80	80	0 - 150	0 - 90
100	100 - 125	0 - 150	0 - 90
125	125	0 - 150	0 - 90
150	150	0 - 120	0 - 75

MG = diaphragm size

All pressures are psi - gauge pressures. Operating pressure values were determined with static operating pressure applied on one side of a closed valve. Sealing at the valve seat and atmospheric sealing is ensured for the given values.

Information on operating pressures applied on both sides and for high purity media on request.

**Pressure rating:** PN 16

**Leakage rate:** Leakage rate A (acc. to EN 12266-1)

**Leakage rate:**

MG	DN	SG iron 40.3 connection type 1, 31	SG iron 40.3 connection type 8, 39	PFA / PP	Hard rubber
<b>25</b>	<b>15</b>	8.0	10.0	5.0	6.0
	<b>20</b>	11.5	14.0	9.0	11.0
	<b>25</b>	11.5	17.0	13.0	15.0
<b>40</b>	<b>32</b>	28.0	36.0	23.0	29.0
	<b>40</b>	28.0	40.0	26.0	32.0
<b>50</b>	<b>50</b>	60.0	68.0	47.0	64.0
	<b>65</b>	-	68.0	-	-
<b>65</b>	<b>65</b>	-	-	72.0	80.0
<b>80</b>	<b>80</b>	-	130.0	110.0	128.0
<b>100</b>	<b>100</b>	-	200.0	177.0	190.0
	<b>125</b>	-	200.0	-	-
<b>125</b>	<b>125</b>	-	-	214.0	230.0
<b>150</b>	<b>150</b>	-	484.0	365.0	397.0

MG = diaphragm size, Kv values in m<sup>3</sup>/h

Kv values determined in accordance with DIN EN 60534, inlet pressure 5 bar, Δp 1 bar, with connection flange EN 1092 length EN 558 series 1 (or threaded socket DIN ISO 228 for body material GGG40.3) and soft elastomer diaphragm. The Kv values for other product configurations (e.g. other diaphragm or body materials) may differ. In general, all diaphragms are subject to the influences of pressure, temperature, the process and their tightening torques. Therefore the Kv values may exceed the tolerance limits of the standard.

The Kv value curve (Kv value dependent on valve stroke) can vary depending on the diaphragm material and duration of use.

**Product compliance**

**Pressure Equipment Directive:** 2014/68/EU

**Food:** FDA\*  
Regulation (EC) No. 1935/2004  
Regulation (EC) No. 10/2011\*

**EAC:** TR CU 010/2011

**TA Luft (German Clean Air Act):** USP  
USP

\* see availability

**Mechanical data**

**Weight:**

**Body**

MG	DN	Threaded socket	Flange
		Connection types code	
		1, 31	8, 38, 39, 51, 53, 56
25	15	1.10	3.31
	20	1.32	4.85
	25	1.98	6.17
40	32	3.09	7.50
	40	4.19	9.92
50	50	5.95	13.89
	65	-	22.71
80	80	-	30.42
100	100	-	45.86
	125	-	57.98
150	150	-	82.23

**Installation position:**

Optional

**Flow direction:**

Optional

**Actuator**

Actuator version	Weight
0	2.43
1	4.63
2	5.95
3	13.01
4	20.94
5	26.46
6	33.07
7	55.12

## Dimensions

### Actuator dimensions

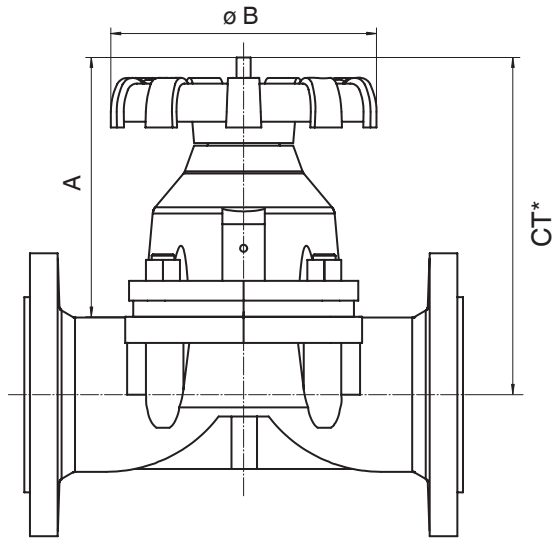

MG	DN	Actuator version	$\varnothing B$	A
25	15 - 25	0	3.78	3.50
40	32 - 40	1	5.16	4.41
50	50 - 65	2	5.16	4.96
65	65	3	7.40	6.73
80	80	4	9.09	7.95
100	100 - 125	5	9.09	8.70
125	125	6	12.44	11.81
150	150	7	12.44	12.80

MG = diaphragm size

Dimensions in inch

\*  $CT = A + H1$  (see body dimensions)

## Body dimensions

### Flange EN (code 8)

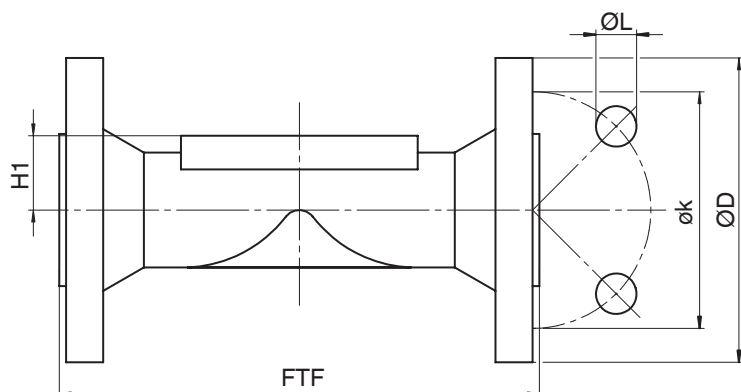

MG	DN	Connection type code 8 <sup>1)</sup>							
		Material code <sup>2)</sup>				17, 18, 83	90	17, 18, 83	90
		øD	øk	øL	n	H1	H1	FTF	FTF
25	15	3.74	2.56	5.51	4	7.09	0.55	5.12	5.12
	20	4.18	2.95	5.51	4	8.07	0.65	5.91	5.91
	25	4.53	3.35	5.51	4	9.06	0.77	6.30	6.30
40	32	5.51	3.94	7.48	4	11.3	0.91	7.09	7.09
	40	5.91	4.33	7.48	4	12.99	1.06	7.87	7.87
50	50	6.50	4.92	7.48	4	15.35	1.26	9.06	9.06
	65	7.28	5.71	19.0	4	-	1.52	-	11.42
65	65	7.28	5.71	7.48	4	20.08	-	11.42	-
80	80	7.87	6.30	7.48	8	23.43	1.24	12.20	12.20
100	100	8.66	7.09	7.48	8	28.74	1.69	13.78	13.78
	125	9.84	8.27	19.0	8	-	2.28	-	15.75
125	125	9.84	8.27	7.48	8	34.25	-	15.75	-
150	150	11.22	9.45	9.06	8	42.91	2.28	18.90	18.90

n = number of bolts

MG = diaphragm size

#### 1) Connection type

Code 8: Flange EN 1092, PN 16, form B, face-to-face dimension FTF EN 558 series 1, ISO 5752, basic series 1, length only for body configuration D

#### 2) Valve body material

Code 17: EN-GJS-400-18-LT (GGG 40.3), PFA lined

Code 18: EN-GJS-400-18-LT (GGG 40.3), PP lined

Code 83: EN-GJS-400-18-LT (GGG 40.3), hard rubber lined

Code 90: EN-GJS-400-18-LT (GGG 40.3)

**Flange EN (code 53)**

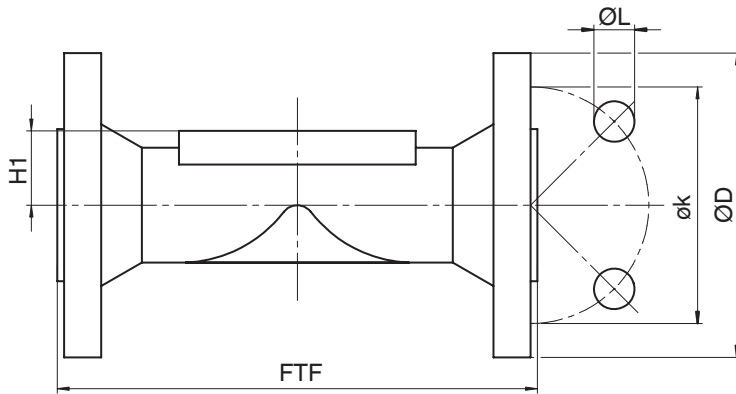

MG	DN	Connection type code 53 <sup>1)</sup>								
		Material code <sup>2)</sup>								
		8	17				8	17	8	17
		øD	øD	øk	øL	n	H1	H1	FTF	FTF
25	15	3.74	-	2.56	5.51	4	7.48	-	4.61	-
	20	4.18	-	2.95	5.51	4	7.48	-	4.61	-
	25	4.53	-	3.35	5.51	4	7.48	-	5.00	-
40	32	5.51	-	3.94	7.48	4	11.02	-	-	-
	40	5.91	-	4.33	7.48	4	11.02	-	6.26	-
50	50	6.50	-	4.92	7.48	4	13.78	-	7.52	-
65	65	7.28	-	5.71	7.48	4	10.83	-	8.50	-
80	80	7.87	-	6.30	7.48	8	12.99	-	10.00	-
100	100	8.66	-	7.09	7.48	8	16.93	-	12.01	-
125	125	9.84	-	8.27	7.48	8	25.59	-	14.02	-
150	150	11.22	110.24 <sup>3)</sup>	9.45	9.06	8	22.83	4.29	15.98	16.38

n = number of bolts

MG = diaphragm size

Dimensions in inch

1) **Connection type**

Code 53: Flange EN 1092, PN 16, form A, face-to-face dimension FTF EN 558 series 7, ISO 5752, basic series 7, length only for body configuration D

2) **Valve body material**

Code 8: EN-GJL-250 (GG 25)

Code 17: EN-GJS-400-18-LT (GGG 40.3), PFA lined

3) Diameter deviates from standard

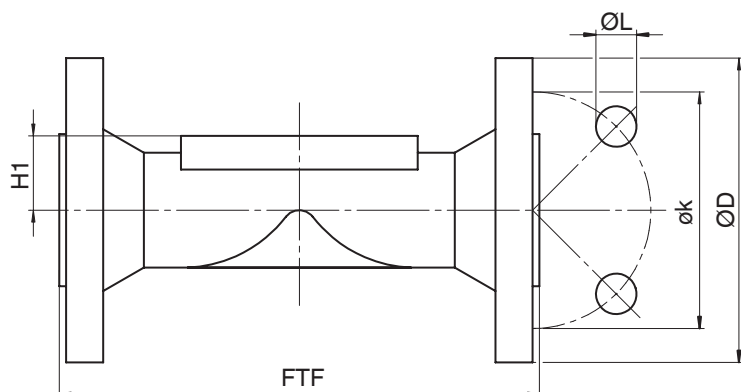

**Flange ANSI Class (code 38, 39)**

MG	DN	Connection types code <sup>1)</sup>											
								38	38	39	39		
								Material code <sup>2)</sup>					
								17, 18, 83	90	17, 18	83	17, 18, 83	90
		øD	øk	øL	n	H1	H1	FTF	FTF	FTF	FTF		
25	15	3.54	2.37	6.26	4	7.09	0.55	-	-	5.12	5.12		
	20	3.94	2.75	6.26	4	8.07	0.65	5.75	5.76	5.91	5.91		
	25	4.33	3.13	6.26	4	9.06	0.77	5.75	5.76	6.30	6.30		
40	32	4.53	3.50	6.26	4	11.3	0.91	-	-	7.09	7.09		
	40	4.92	3.87	6.26	4	12.99	1.06	6.89	6.75	7.87	7.87		
50	50	5.91	4.75	7.48	4	15.35	1.26	7.87	7.77	9.06	9.06		
	65	7.09	5.50	19.0	4	-	1.52	-	-	-	11.42		
65	65	7.09	5.50	7.48	4	20.08	-	8.90	8.76	11.42	-		
80	80	7.48	6.00	7.48	4	23.43	1.24	10.24	10.25	12.20	12.20		
100	100	9.06	7.50	7.48	8	28.74	1.69	12.87	12.77	13.78	13.78		
	125	10.04	8.50	22.2	8	-	2.28	-	-	-	15.75		
125	125	10.04	8.50	8.74	8	34.25	-	-	-	15.75	-		
150	150	11.02	9.50	8.74	8	42.91	2.28	16.38	16.38	18.90	18.90		

n = number of bolts

MG = diaphragm size

Dimensions in inch

**1) Connection type**

Code 38: Flange ANSI Class 150 RF, length only for body configuration D acc. to MSS SP-88

Code 39: Flange ANSI Class 125/150 RF, length only for body configuration D acc. to EN 558 series 1, ISO 5752, basic series 1

**2) Valve body material**

Code 17: EN-GJS-400-18-LT (GGG 40.3), PFA lined

Code 18: EN-GJS-400-18-LT (GGG 40.3), PP lined

Code 83: EN-GJS-400-18-LT (GGG 40.3), hard rubber lined

Code 90: EN-GJS-400-18-LT (GGG 40.3)

**Flange ANSI Class (code 56)**

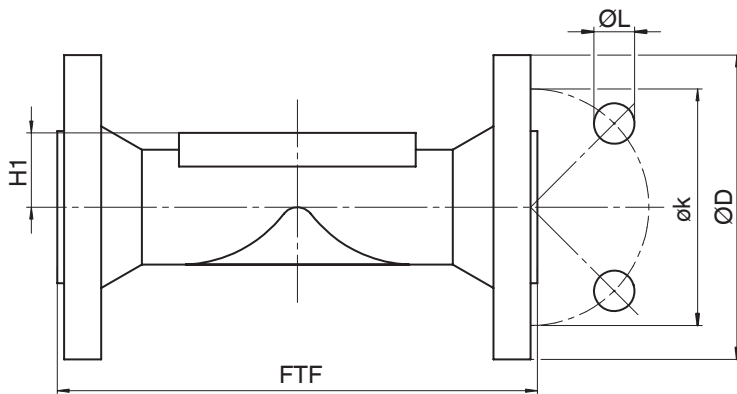

MG	DN	Connection type code 56 <sup>1)</sup>							
		Material code <sup>2)</sup>				17	81, 91	17	81, 91
		øD	øk	øL	n	H1	H1	FTF	FTF
25	25	4.33	3.13	6.26	4	-	0.91	-	5.0
40	40	4.92	3.87	6.26	4	-	1.26	-	6.50
50	50	5.91	4.75	7.48	4	-	1.57	-	7.52
80	80	7.48	6.00	7.48	4	-	2.28	-	10.0
100	100	9.06	7.50	7.48	8	-	2.76	-	12.24
150	150	11.02	9.50	8.74	8	4.29	-	16.38	-

n = number of bolts  
 MG = diaphragm size  
 Dimensions in inch

1) **Connection type**

Code 56: Flange ANSI Class 125/150 RF, face-to-face dimension FTF EN 558 series 7, ISO 5752, basic series 7, length only for body configuration D

2) **Valve body material**

Code 17: EN-GJS-400-18-LT (GGG 40.3), PFA lined  
 Code 81: EN-GJS-500-7 (GGG 50), PFA lined  
 Code 91: EN-GJS-500-7 (GGG 50), PP lined

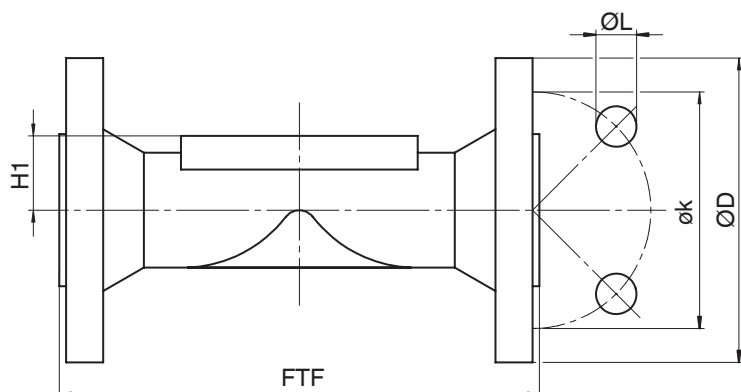
**Flange BS (code 51)**

MG	DN	Connection type code 51 <sup>1)</sup>							
		Material code <sup>2)</sup>				17	81, 91	17	81, 91
		øD	øk	øL	n	H1	H1	FTF	FTF
<b>25</b>	<b>25</b>	4.49	3.27	5.51	4	-	0.91	-	5.0
<b>40</b>	<b>40</b>	4.92	3.86	5.51	4	-	1.26	-	6.50
<b>50</b>	<b>50</b>	5.98	4.49	6.69	4	-	1.57	-	7.52
<b>80</b>	<b>80</b>	7.24	5.75	6.69	4	-	2.28	-	10.0
<b>100</b>	<b>100</b>	8.50	7.01	6.69	8	-	2.76	-	12.24
<b>150</b>	<b>150</b>	10.98	9.25	8.66	8	4.29	-	16.38	-

n = number of bolts

MG = diaphragm size

Dimensions in inch

1) **Connection type**

Code 51: Flange BS 10 Table E, face-to-face dimension FTF EN 558 series 7, ISO 5752, basic series 7, length only for body configuration D

2) **Valve body material**

Code 17: EN-GJS-400-18-LT (GGG 40.3), PFA lined

Code 81: EN-GJS-500-7 (GGG 50), PFA lined

Code 91: EN-GJS-500-7 (GGG 50), PP lined

**Threaded socket DIN (code 1)**

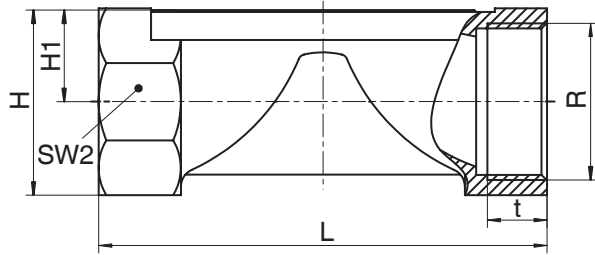

Connection type threaded socket (code 1)<sup>1)</sup>, SG iron material (code 90)<sup>2)</sup>

MG	DN	NPS	H	H1	L	n	R	SW 2	t
25	15	1/2"	1.29	0.66	3.35	6	G 1/2	32	0.59
	20	3/4"	1.65	0.85	3.35	6	G 3/4	41	0.64
	25	1"	1.84	0.93	4.33	6	G 1	46	0.75
40	32	1 1/4"	2.20	1.12	4.72	6	G 1 1/4	55	0.84
	40	1 1/2"	2.60	1.32	5.51	6	G 1 1/2	65	0.84
50	50	2"	2.99	1.52	6.50	6	G 2	75	1.01

n = number of flats  
 MG = diaphragm size  
 Dimensions in inch

- 1) **Connection type**  
Code 1: Threaded socket DIN ISO 228
- 2) **Valve body material**  
Code 90: EN-GJS-400-18-LT (GGG 40.3)

**Threaded socket NPT (code 31)**

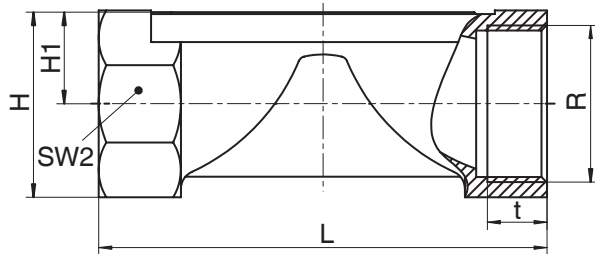

Connection type threaded socket NPT (code 31)<sup>1)</sup>, SG iron material (code 90)<sup>2)</sup>

MG	DN	NPS	H	H1	L	n	R	SW 2	t
25	15	1/2"	1.29	0.66	3.35	6	NPT 1/2	32	0.54
	20	3/4"	1.65	0.85	3.35	6	NPT 3/4	41	0.56
	25	1"	1.84	0.93	4.33	6	NPT 1	46	0.66
40	32	1 1/4"	2.20	1.12	4.72	6	NPT 1 1/4	55	0.68
	40	1 1/2"	2.60	1.32	5.51	6	NPT 1 1/2	65	0.68
50	50	2"	2.99	1.52	6.50	6	NPT 2	75	0.70

n = number of flats  
 Dimensions in inch  
 MG = diaphragm size

- 1) **Connection type**  
Code 31: NPT female thread
- 2) **Valve body material**  
Code 90: EN-GJS-400-18-LT (GGG 40.3)



GEMÜ Gebr. Müller Apparatebau GmbH & Co. KG  
Fritz-Müller-Straße 6-8, 74653 Ingelfingen-Criesbach, Germany  
Tel. +49 (0)7940 123-0 · info@gemue.de  
www.gemu-group.com

## SPECIFICATIONS

# FIGURE 731 AND 732 BUTTERFLY VALVE



## RESILIENT-SEATED BUTTERFLY VALVE

FNW cartridge-style resilient-seated butterfly valves are designed to meet the rigorous requirements of industrial applications, such as pulp and paper, water purification, power and utilities, chemical/petrochemical, food and beverage, OEM and HVAC. Each valve is manufactured in accordance with independent standards specifications and is 100% tested in both directions of operation to assure bubble-tight service for many years.

### FEATURES

- Designed for 125/150 lbs flanges
- Standard stainless steel disc and stem offer superior strength and chemical resistance
- Mounting pad with square shaft permits direct mount actuation that reduces hysteresis and cost (2"–12")
- Secured stem retainer plate for blowout-proof protection allows operator removal with valve in line
- High-strength two-piece stem eliminates taper pins and disc screws from flow path
- Rated to 255 psi (2"–12"), 188 psi (14"–24")
- Cartridge-style seat permits easy change without special tools
- Molded O-ring eliminates the need for flange gasket\*
- Lockable handles
- Shell tested to 150% and seat tested to 110% of maximum working pressure
- Wafer bodies cast iron to 10", ductile iron 12" to 24", and ductile iron lug bodies to 24"
- Dual PTFE shaft bearings for reduced torque and improved stem alignment
- Vacuum rated to 29.9" Hg (0.01 Torr)<sup>†</sup>
- Epoxy-coated body
- Low-maintenance design
- Sizes 2"–24"

### PRODUCT SPECIFICATIONS

#### Standards

- NSF 61 and NSF 372 (UL) Certified  
Applies only to EPDM seated valves
- Design: API 609A and MSS SP-67
- Seat tested: MSS SP-61
- Top Flange: ISO 5211

#### Options

FNW offers many options and modifications for valves. These include, but are not limited to: Actuation including chain wheels, square drive nuts, worm-gear operators, and pneumatic and electric operators, control accessories, stem extensions, and custom mounting hardware. Contact FNW with your specific application needs.



Fig. 731

Fig. 732

\*Pressed collar-style angle face rings (typically sizes 2" to 6") are not recommended due to the large radius of the inner diameter. Cast type angle face rings or stub ends should be used with light wall stainless steel piping. Prior to installation, always verify that the connecting piping flange face fully engages the valve seat face.

<sup>†</sup>Vacuum measurements are often made in inches of mercury below atmospheric pressure. The values calculated here assume standard atmospheric pressure of 29.92 inches of mercury.

SPECIFICATIONS

**FIGURE 731 AND 732**  
BUTTERFLY VALVE



RESILIENT-SEATED BUTTERFLY VALVE

731 WAFER AND 732 LUGGED – SIZES 2" TO 12" (ALSO AVAILABLE WITH GEAR)\*

\*Gear operator recommended above 8"

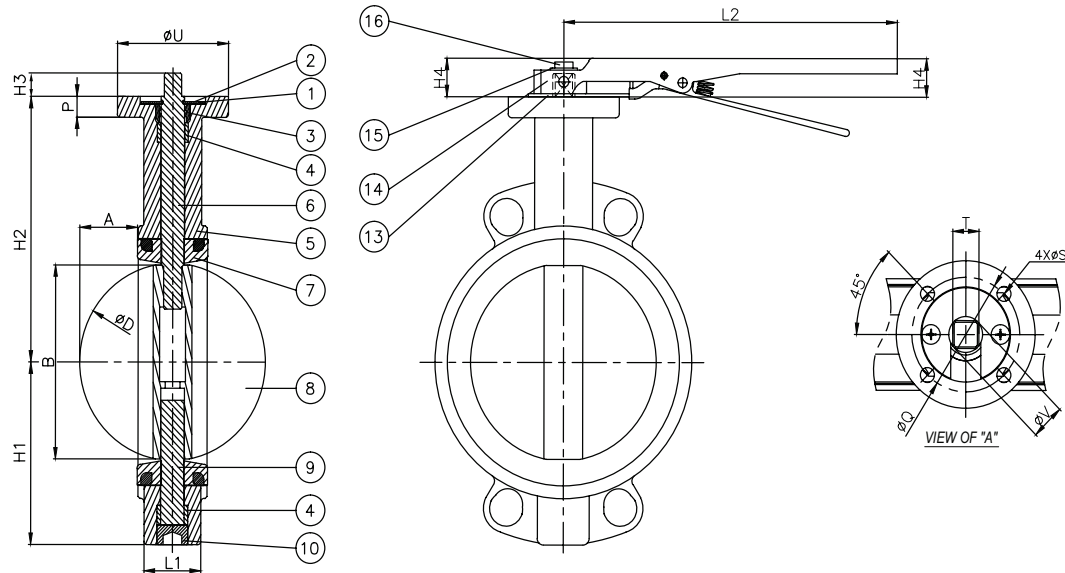

731 WAFER AND 732 LUGGED – SIZES 14" TO 24"

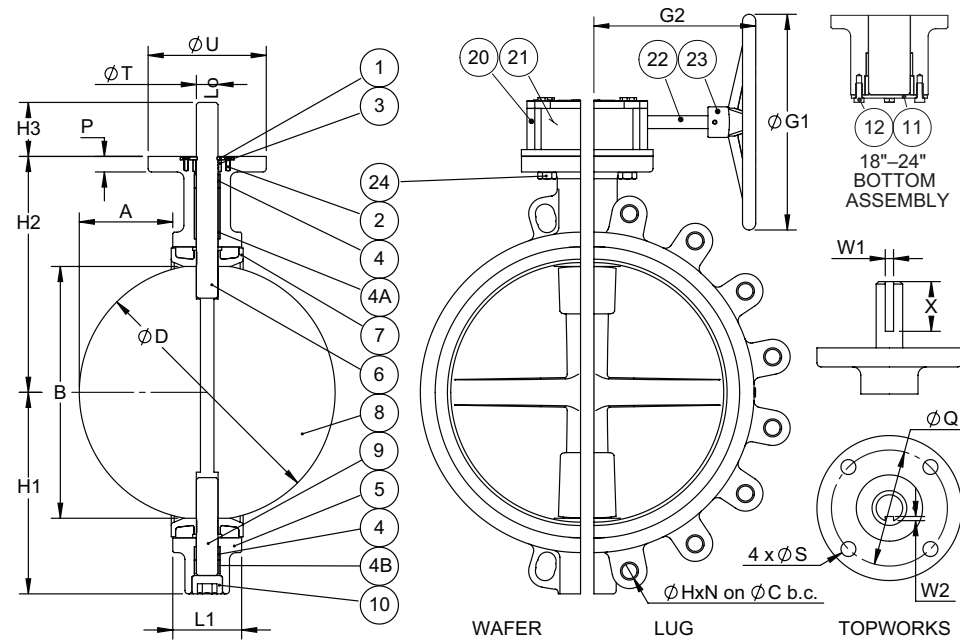

SPECIFICATIONS

**FIGURE 731 AND 732**  
BUTTERFLY VALVE



RESILIENT-SEATED BUTTERFLY VALVE

DIMENSIONS (INCHES) SIZES 2" TO 12"

Size	A	B	ØD	H1		H2		H3	H4	L1	L2
				731	732	731	732				
2"	0.18	1.93	2.05	2.77	2.77	5.06	4.94	0.60	1.15	1.69	10.64
2-1/2"	0.41	2.52	2.64	2.95	2.95	5.36	5.20	0.60	1.15	1.81	10.64
3"	0.67	3.03	3.15	3.67	3.67	5.64	6.07	0.60	1.15	1.81	10.64
4"	0.94	3.82	3.94	4.18	4.18	6.41	6.54	0.70	1.15	2.05	10.64
5"	1.36	4.80	4.92	4.69	4.69	7.34	7.13	0.70	1.15	2.20	10.64
6"	1.86	5.83	5.93	5.48	5.48	7.98	7.99	0.70	1.15	2.20	10.64
8"	2.69	7.62	7.74	6.51	6.51	9.34	9.34	0.81	1.14	2.36	15.37
10"	3.52	9.65	9.72	7.86	7.86	11.13	10.50	0.81	1.14	2.68	16.99
12"	4.28	11.54	11.63	9.47	9.47	12.27	12.15	0.95	1.14	3.07	16.99

Size	G1	G2	ØC	ØH	N	ØU	P	ØQ	ØS	T	ØV
2"	5.79	6.00	4.75	5/8"-11	4	3.54	0.55	2.76	0.35	0.43	0.55
2-1/2"	5.79	6.00	5.49	5/8"-11	4	3.54	0.55	2.76	0.35	0.43	0.55
3"	5.79	6.00	6.00	5/8"-11	4	3.54	0.55	2.76	0.35	0.43	0.55
4"	5.79	6.00	7.50	5/8"-11	8	3.54	0.63	2.76	0.35	0.55	0.63
5"	5.79	6.00	8.50	3/4"-10	8	3.54	0.63	2.76	0.35	0.55	0.71
6"	5.79	6.00	9.51	3/4"-10	8	3.54	0.63	2.76	0.35	0.55	0.71
8"	11.22	9.07	11.75	3/4"-10	8	3.54	0.67	2.76	0.35	0.67	0.87
10"	11.22	9.07	14.25	7/8"-9	12	4.92	0.79	4.02	0.43	0.87	1.00
12"	11.22	8.76	17.00	7/8"-9	12	4.92	0.79	4.02	0.43	0.87	1.10

DIMENSIONS (INCHES) SIZES 14" TO 24"

Size	A	B	ØD	H1	H2	G1	G2	L1	ØC	ØH
14"	4.96	12.83	12.99	10.41	13.60	11.22	8.76	3.07	18.75	1"-8
16"	5.45	14.82	14.92	11.75	13.76	11.22	8.76	4.02	21.25	1"-8
18"	6.36	17.09	17.20	13.78	15.75	15.43	9.01	4.49	22.75	1-1/8"-7
20"	7.15	19.13	19.29	14.96	17.32	15.43	10.66	5.00	25.00	1-1/8"-7
24"	8.28	22.46	22.62	17.32	20.08	15.43	10.66	6.06	29.50	1-1/8"-7

Size	N	H3	ØU	P	ØQ	ØS	ØT	W1	W2	X
14"	12	2.81	4.92	0.79	4.02	0.47	1.10	0.39	0.20	2.36
16"	16	3.15	6.89	0.91	5.51	0.71	1.26	0.39	0.20	2.36
18"	16	3.15	6.89	0.91	5.51	0.71	1.50	0.47	0.20	2.36
20"	20	3.54	8.27	0.91	6.50	0.87	1.77	0.47	0.20	2.76
24"	20	3.74	8.27	0.91	6.50	0.87	2.17	0.55	0.20	2.76



SPECIFICATIONS

**FIGURE 731 AND 732**  
BUTTERFLY VALVE



RESILIENT-SEATED BUTTERFLY VALVE

PART MATERIALS AND QUANTITY

Ref. No.	Description	Material	Qty	Remarks
1	Retaining Plate	ASTM A283D-A36 STEEL	1	Galvanized
2	Retaining Plate Screw	ASTM A283D-A36 STEEL	2	Galvanized
			3	
3	Ingress Stem Seal	SAME AS SEAT MATERIAL	1	—
4	Stem Bushing	PTFE	2	1 Upper, 1 Lower, Sizes 2"–3", 14"–24"
			4	2 Upper, 2 Lower, Sizes 4"–14"
4A	Upper Hard Bushing	ASTM B584 C83600 BRONZE	1	Sizes 14"–24"
4B	Lower Hard Bushing	ASTM B584 C83600 BRONZE	1	Sizes 14"–24"
5	Body	ASTM A126 CAST IRON	1	Fig 731, Sizes 2"–10"
		ASTM A536 65-45-12 DUCTILE IRON		Fig 731, Sizes 12" and Up, Fig 732 All
6	Upper Stem	ASTM A276 SUS 316 STAINLESS	1	—
7	Seat	EPDM or BUNA	1	—
		VITON		Sizes 2"–12"
8	Disc	ASTM A351 CF8M, STAINLESS	1	—
9	Lower Stem	ASTM A276 SUS 316 STAINLESS	1	—
10	Plug	ASTM A283D-A36 STEEL	1	Sizes 2"–16"
11	Bottom Plate	ASTM A283D-A36 STEEL	1	Zinc Plated, Sizes 18"–24"
12	Bottom Plate Screw	ASTM A283D-A36 STEEL	4	Zinc Plated, Sizes 18"–24"
13	Lever Stop Plate	ASTM A283D-A36 STEEL	1	Nickel Plated, Sizes 2"–8"
14	Lever	ASTM A47 Gr 32510 MALLEABLE IRON	1	Sizes 2"–8"
15	Lever Washer	ASTM A283D-A36 STEEL	1	Zinc Plated, Sizes 2"–8"
16	Lever Bolt	ASTM A283D-A36 STEEL	1	Zinc Plated, Sizes 2"–8"
20	Gear Housing	ASTM A126 CAST IRON	1	Sizes 10"–24" Standard
21	Gear Drive	ASTM A536 65-45-12 DUCTILE IRON	1	Sizes 10"–24" Standard, Not Shown
22	Gear Input Shaft	STEEL	1	Nickel Plated, Sizes 10"–24"
23	Hand Wheel	ASTM A126 CAST IRON	1	Sizes 10"–24"
24	Gear Mounting bolt	ASTM A283D-A36 STEEL	4	Zinc Plated, Sizes 10"–24"

Standard configurations are with levers up to 12" and gear operators 14" to 24". Gear operators recommended for sizes 8" and above.

FIGURE NUMBER MATRIX

FNW731EGX			
Body Type	Seat	Operator	Size Code
1 = Water	E = EPDM	Blank = 10 Position	2 = K    10 = 10
			2-1/2 = L    12 = 12
2 = Lug	B = Buna-N	Lever (2"-12")	3 = M    14 = 14
			4 = P    16 = 16
	V = Viton®	G = Gear Operator (2"-24")	5 = S    18 = 18
			6 = U    20 = 20
			8 = X    24 = 24

REPLACEMENT SEATS

FNWB731X		
Seat	Size Code	
E = EPDM	2 = K	10 = 10
	2-1/2 = L	12 = 12
B = Buna-N	3 = M	14 = 14
	4 = P	16 = 16
	5 = S	18 = 18
	6 = U	20 = 20
	8 = X	24 = 24

SPECIFICATIONS

**FIGURE 731 AND 732**  
BUTTERFLY VALVE



RESILIENT-SEATED BUTTERFLY VALVE

WEIGHT (LBS)

Size	Wafer/ Lever	Wafer/ Gear	Lug/ Lever	Lug/ Gear
2"	7.8	15.9	8.0	16.0
2-1/2"	8.8	16.9	9.9	18.0
3"	9.4	17.5	10.3	18.4
4"	10.8	19.0	15.3	23.5
5"	15.2	23.4	19.4	27.6
6"	18.4	26.6	21.5	29.7
8"	27.3	42.9	36.1	51.7
10"	—	61.1	58.1	74.8
12"	—	82.0	81.1	103.0
14"	—	107.6	—	146.2
16"	—	161.8	—	196.0
18"	—	202.0	—	268.3
20"	—	305.1	—	367.8
24"	—	472.1	—	522.6

TORQUE (IN-LBS)

Size	EPDM & BUNA Seat	VITON Seat
2"	367	477
2-1/2"	367	477
3"	480	624
4"	593	771
5"	649	844
6"	971	1262
8"	1896	2465
10"	4006	5208
12"	4627	6015
14"	13385	17401
16"	17506	22758
18"	23542	30605
20"	29076	37799
24"	46874	60901

SEAT TEMPERATURES

Seat Material	Working Temperature
EPDM	-22° to 230°F (-30°C to 110°C)
Buna-N	-4° to 194°F (-20°C to 90°C)
Viton	-14° to 320°F (-25°C to 160°C)

1. All unseating torques based on non-corrosive clean, wet or lubricating service at ambient temperatures. Contact FNW for dry or application specific torque.
2. For line velocities greater than 15 FPS, dynamic torque must be taken into consideration.
3. All torques are based on maximum pressure differential for the valve.
4. Torque values shown are reflective of a 30% safety factor.

CV (FLOW COEFFICIENT)

SIZE	DEGREES of DISC OPENING							
	20°	30°	40°	50°	60°	70°	80°	90°
2"	8	9	18	28	55	72	110	135
2-1/2"	10	15	27	44	85	110	168	210
3"	15	23	39	65	130	165	250	310
4"	27	41	71	115	230	300	465	540
5"	58	86	150	245	480	610	980	1100
6"	96	140	245	400	785	1010	1615	1910
8"	165	245	410	685	1275	1715	2670	3185
10"	255	380	650	1130	2100	2700	4250	4900
12"	370	540	950	1570	3050	3950	5950	7350
14"	450	750	1300	2210	4080	5610	8078	11200
16"	640	900	1720	2790	5000	7650	10770	12900
18"	730	1250	2295	3700	7050	9180	13900	17500
20"	910	1595	2850	4630	8600	11500	17540	22400
24"	1250	2290	4000	6090	12500	16500	23590	28300

Cv is the volume of water in U.S. gallons per minute that passes through the valve at a pressure drop of 1 psi at 68°F.

# FIGURE HPA BUTTERFLY VALVES



## HIGH-PERFORMANCE BUTTERFLY VALVE

### FEATURES

- Class 150 and 300 wafer or lug style
- Carbon steel (WCB) and stainless steel (CF8M) body
- Available in fire safe configuration (WCB only)
- Double offset design with conical angled disc
- Bidirectional bubble-tight shutoff
- Lug-style ASME rated for dead-end service in both directions
- Standard HyperSeat™ rated to 500°F
- Suitable for saturated steam service to 150 psi
- ISO 5211 mounting flange
- Blowout-proof stem
- Integral cast disc over-travel stop
- Live loaded packing adjustable without actuator removal
- Manufactured in ISO 9001 Facility

### PRODUCT SPECIFICATIONS

#### Standards:

- Design: API 609
- Mounting Pad: ISO 5211
- End Flange: ASME B16.5
- Face to Face: API 609
- Pressure/Temp Rating: ASME B16.34
- Shell/Seat Test: API 598
- Emissions Compliance: ISO 15848-1
- NSF 61 and NSF 372 (UL) Certified  
Applies only to SS construction thru 24"

#### Options

FNW offers many options and modifications for valves. These include, but are not limited to: Actuation including chain wheels, square drive nuts, worm-gear operators and pneumatic and electric operators. Also available are various control accessories, stem extensions and custom mounting hardware. Contact FNW with your specific application needs.

\*\* Vacuum measurements are often made in inches of mercury below atmospheric pressure. The values calculated here assume standard atmospheric pressure of 29.92 inches of mercury.



# FIGURE HPA BUTTERFLY VALVES



## HIGH-PERFORMANCE BUTTERFLY VALVE

### WAFER AND LUG (2"-12")

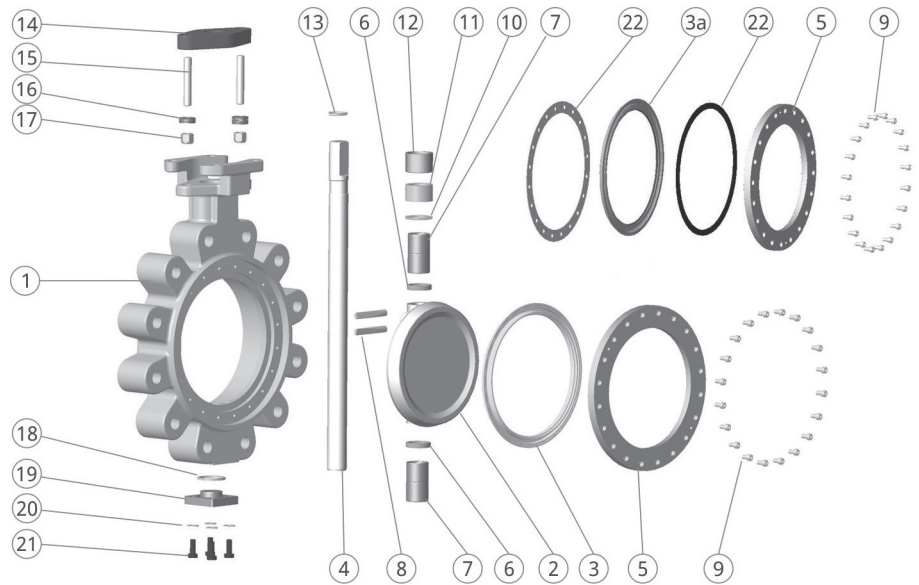

### STANDARD MATERIALS OF CONSTRUCTION

Item	Component	WCB	CF8M
1	Body	ASTM A216 WCB	ASTM A351 CF8M
2	Disc	ASTM A351 CF8M	ASTM A351 CF8M
3	Seat (Soft)	HyperSeat	HyperSeat
3a	Seat (Fire Seat)	ASTM A240 SS 316 + HyperSeat	ASTM A240 SS 316 + HyperSeat
4	Stem (for Soft Seat)	ASTM A564 Type 630 (17-4PH)	ASTM A479 SS316 LEVEL 2
	Stem (for Fire Safe)	ASTM A564 Type 630 (17-4PH)	ASTM A564 Type 630 (17-4PH)
5	Seat Retaining Ring	Carbon Steel	ATM A240 SS316
6	Disc Spacer	ASTM A479 SS316	ASTM A479 SS316
7	Bearing (Soft Seat)	Bear-X	Bear-X
	Bearing (Fire Safe)	Fireproof FFP-D1	Fireproof FFP-D1
8	Wedge Key	ASTM A564 Type 630 (17-4PH)	ASTM A564 Type 630 (17-4PH)
9	Retainer Screw	ISO 3506 A4-70	ISO 3506 A4-70
10	Packing Spacer	ASTM A479 SS316	ASTM A479 SS316

Item	Component	WCB	CF8M
11	Gland Packing	PTFE (Chevron V-Ring)	PTFE (Chevron V-Ring)
12	Gland	ASTM A479 SS316	ASTM A479 SS316
13	Stem Retainer	ASTM A313 SS302	ASTM A313 SS302
14	Gland Flange	ASTM A105/ ASTM A216 WCB/ Carbon Steel	ASTM A240 SS316/ ASTM A351 CF8M/ASTM A182 F316
15	Stud	ASTM A193 Gr B8M	ASTM A193 Gr B8M
16	Belleville Spring	ASTM A666 SS 304	ASTM A666 SS 304
17	Hex Nut	ASTM A194 Gr 8M	ASTM A194 Gr 8M
18	Cover Gasket	PTFE	PTFE
19	Bottom Cover	Carbon Steel	ASTM A240 SS316
20	Spring Washer	ASTM A580 SS304	ASTM A580 SS304
21	Hex Head Bolt	ISO 3506 A4 -70	ISO 3506 A4 -70
22	Seat Gasket (Fire Safe)	Graphite	Graphite

# FIGURE HPA BUTTERFLY VALVES



## HIGH-PERFORMANCE BUTTERFLY VALVE

### WAFER AND LUG (14"-36")

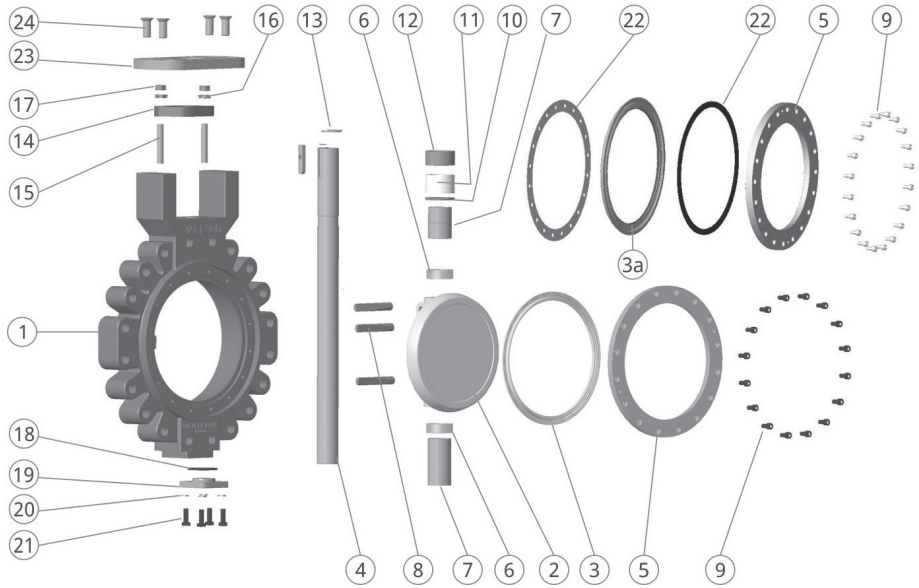

### STANDARD MATERIALS OF CONSTRUCTION

Item	Component	WCB	CF8M
1	Body	ASTM A216 WCB	ASTM A351 CF8M
2	Disc	ASTM A351 CF8M	ASTM A351 CF8M
3	Seat (Soft)	HyperSeat	HyperSeat
4	Stem (for Soft Seat)	ASTM A564 Type 630 (17-4PH)	ASTM A564 Type 630 (17-4PH)
	Stem (for Fire Safe)	ASTM A564 Type 630 (17-4PH)	ASTM A564 Type 630 (17-4PH)
5	Seat Retaining Ring	Carbon Steel	ATM A240 SS316
6	Disc Spacer	ASTM A479 SS316	ASTM A479 SS316
7	Bearing (Soft Seat)	Bear-X	Bear-X
	Bearing (Fire Safe)	Fireproof FFP-D1	Fireproof FFP-D1
8	Wedge Key	ASTM A564 Type 630 (17-4PH)	ASTM A564 Type 630 (17-4PH)
9	Retainer Screw	ISO 3506 A4-70	ISO 3506 A4-70
10	Packing Spacer	ASTM A479 SS316	ASTM A479 SS316
11	Gland Packing	PTFE (Chevron V-ring)	PTFE (Chevron V-ring)

Item	Component	WCB	CF8M
12	Gland	ASTM A479 SS316	ASTM A479 SS316
13	Stem Retainer	ASTM A313 SS302	ASTM A313 SS302
14	Gland Flange	ASTM A105/ ASTM A216 WCB/ Carbon Steel	ASTM A 240 SS316/ ASTM A351 CF8M/ASTM A182 F316
15	Stud	ASTM A193 Gr B8M	ASTM A193 Gr B8M
16	Belleville Spring	ASTM A666 SS 304	ASTM A666 SS 304
17	Hex Nut	ASTM A194 Gr 8M	ASTM A194 Gr 8M
18	Cover Gasket	PTFE	PTFE
19	Bottom Cover	Carbon steel	ASTM A240 SS316
20	Spring Washer	ASTM A580 SS304	ASTM A580 SS304
21	Hex Head Bolt	ISO 3506 A4 -70	ISO 3506 A4 -70
22	Seat Gasket (Fire Safe)	Graphite	Graphite
23	Mounting plate (Iso Plate)	Carbon steel	ASTM A240 SS316
24	Counter sunk screw	ISO 3506 A4 -70	ISO 3506 A4 -70

# FIGURE HPA BUTTERFLY VALVES



## HIGH-PERFORMANCE BUTTERFLY VALVE

### DIMENSIONS AND WEIGHTS WAFER AND LUG

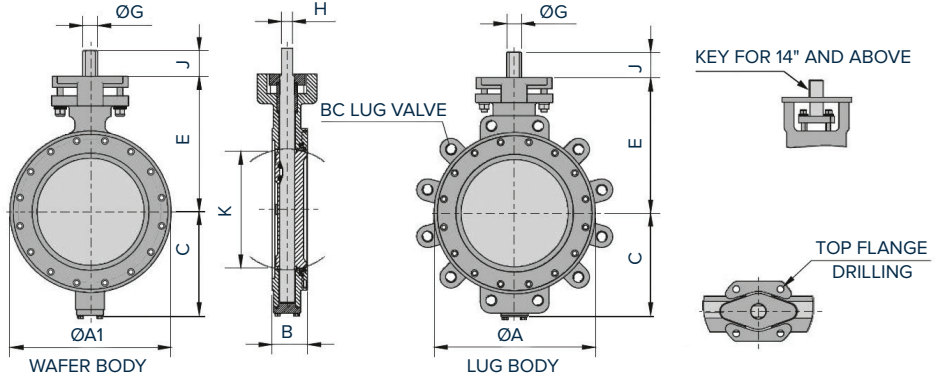

#### ASME CLASS 150 DIMENSIONS (INCHES)

Valve Size		Top Flanged Drilling						Lug Drilling D			App. Weight (lbs)								
Inch	DN	ØA	ØA1	*B	C	E	BC	No. of Holes	Hole Dia.	ØG	H	J	KEY SIZE	K	BC	No. of Holes	Tapping/UNC/UN2B	Wafer	Lug
2	50	3.82	3.82	1.69	2.68	4.92	2.76	4	0.39	0.55	0.39	1.26	-	1.57	4.75	4	5/8-11	7.3	9.5
2-1/2	65	4.13	4.13	1.81	2.95	5.75	2.76	4	0.39	0.63	0.43	1.26	-	2.19	5.50	4	5/8-11	8.8	11.0
3	80	5.47	5.47	1.89	4.25	5.91	2.76	4	0.39	0.63	0.43	1.26	-	2.69	6.00	4	5/8-11	13.9	15.4
4	100	6.69	6.69	2.13	4.84	6.77	2.76	4	0.39	0.63	0.43	1.26	-	3.53	7.50	8	5/8-11	18.3	26.5
5	125	7.32	7.32	2.24	4.72	7.40	2.76/4.02	4	0.39/0.43	0.75	0.51	1.26	-	4.36	8.50	8	3/4-10	19.8	29.5
6	150	8.50	8.50	2.24	5.83	8.07	2.76/4.02	4	0.39/0.47	0.75	0.51	1.26	-	5.46	9.50	8	3/4-10	30.9	35.3
8	200	10.59	10.59	2.52	6.81	9.45	4.92	4	0.55	0.87	0.63	1.26	-	7.21	11.75	8	3/4-10	48.5	63.9
10	250	12.76	12.76	2.80	8.54	10.71	4.92	4	0.55	1.18	0.87	2.01	-	9.16	14.25	12	7/8-9	70.5	94.9
12	300	15.00	14.88	3.19	9.80	12.20	4.92	4	0.55	1.38	0.94	2.01	-	10.93	17.00	12	7/8-9	106.9	147.7
14	350	16.26	16.26	3.62	11.18	15.94	4.92/5.51	4	0.55/0.71	1.57	-	2.01	0.47 x 0.31	12.12	18.75	12	1-8	185.2	238.1
16	400	18.50	18.50	4.02	12.40	17.95	5.51/6.50	4	0.71/0.87	1.97	-	2.52	0.47 x 0.31	13.94	21.26	16	1-8	260.1	328.5
18	450	21.02	21.02	4.49	13.35	19.33	5.51/6.50	4	0.71/0.87	2.17	-	2.52	0.63 x 0.39	15.94	22.75	16	1-1/8-8	339.5	390.2
20	500	22.99	22.99	5.00	14.76	21.10	6.50	4	0.87	2.36	-	4.02	0.71 x 0.43	17.57	25.00	20	1-1/8-8	449.7	566.6
24	600	27.36	27.36	6.06	17.24	24.96	6.50/10	8	0.87/0.71	2.76	-	4.02	0.79 x 0.47	20.97	29.50	20	1-1/4-8	776.0	892.9
26	650	29.49	29.49	6.50	18.70	26.93	10.00	8	0.71	3	-	4.02	0.75 x 0.75	23.82	31.75	24	1-1/4-8	1135.0	1365.0
28	700	31.50	30.00	6.50	19.69	28.74	10/11.73	8	0.71/0.87	3	-	4.02	0.75 x 0.75	24.61	34.00	28	1-1/8-8	1135.4	1366.9
30	750	33.74	33.74	7.48	21.26	28.35	10/11.73	8	0.71/0.87	3.50	-	4.02	0.88 x 0.63	25.59	36.00	28	1-1/4-8	1140.0	1580.7
32	800	35.98	34.02	7.48	22.05	30.75	11.73	8	0.87	3.50	-	4.02	0.88 x 0.63	27.44	38.50	28	1-1/2-8	1450.6	1873.9
36	900	40.24	37.99	7.99	25.59	33.86	11.73	8	0.87	4.00	-	5.27	100 x 0.75	31.00	42.75	32	1-1/2-8	1907.0	2641.1

#### ASME CLASS 300 DIMENSIONS (INCHES)

2	50	4.02	4.02	1.69	3.39	5.24	2.76	4	0.39	0.55	0.39	1.26	-	1.49	5.00	8	5/8-11	7.7	11.0
2-1/2	65	4.13	4.13	1.81	3.86	5.75	2.76	4	0.39	0.63	0.43	1.26	-	1.99	5.87	8	3/4-10	8.8	12.1
3	80	5.20	5.47	1.89	4.29	6.22	2.76	4	0.39	0.63	0.43	1.26	-	2.67	6.63	8	3/4-10	13.4	18.7
4	100	6.69	6.69	2.13	4.84	6.77	2.76	4	0.39	0.63	0.43	1.26	-	3.55	7.87	8	3/4-10	19.0	26.5
5	125	7.32	7.32	2.32	5.47	7.99	2.76/4.02	4	0.39/0.47	0.75	0.51	1.26	-	4.17	9.25	8	3/4-10	20.3	36.8
6	150	8.50	8.50	2.32	6.42	8.66	2.76/4.02	4	0.39/0.47	0.87	0.63	1.26	-	5.42	10.63	12	3/4-10	39.7	55.1
8	200	10.63	10.63	2.87	7.87	10.94	4.92	4	0.55	1.18	0.87	2.01	-	7.16	13.00	12	7/8-9	70.5	94.8
10	250	12.83	12.83	3.27	9.06	11.81	4.92	4	0.55	1.38	0.94	2.01	-	8.87	15.25	16	1-8	88.6	134.5
12	300	15.00	15.00	3.62	10.51	13.43	5.51/6.50	4	0.71/0.87	1.57	1.14	2.01	-	10.75	17.75	16	1-1/8-8	172.4	220.5
14	350	16.26	16.26	4.61	12.40	17.99	5.51/6.50	4	0.71/0.87	2.17	-	2.52	0.63 x 0.39	11.38	20.25	20	1-1/8-8	286.6	381.4
16	400	18.50	18.50	5.24	14.37	20.79	6.50	4	0.87	2.17	-	2.52	0.63 x 0.39	13.37	22.50	20	1-1/4-8	392.4	493.8
18	450	20.98	20.98	5.87	15.08	23.27	10.00	8	0.71	2.76	-	4.02	0.79 x 0.47	14.99	24.75	24	1-1/4-8	485.0	848.8
20	500	22.99	22.99	6.26	17.17	23.70	10/11.73	8	0.71/0.87	3.15	-	4.02	0.87 x 0.55	16.07	27.00	24	1-1/4-8	877.4	988.7
24	600	27.24	27.24	7.13	19.84	31.30	11.73	8	0.87	3.94	-	5.28	1.10 x 0.63	19.71	32.00	24	1-1/2-8	1157.4	1862.9

Face to Face dimension "B" conforms to API 609 Category B up to 24" CL 150 and CL 300.



# FIGURE HPA BUTTERFLY VALVES



## HIGH-PERFORMANCE BUTTERFLY VALVE

### LEVER DIMENSIONS

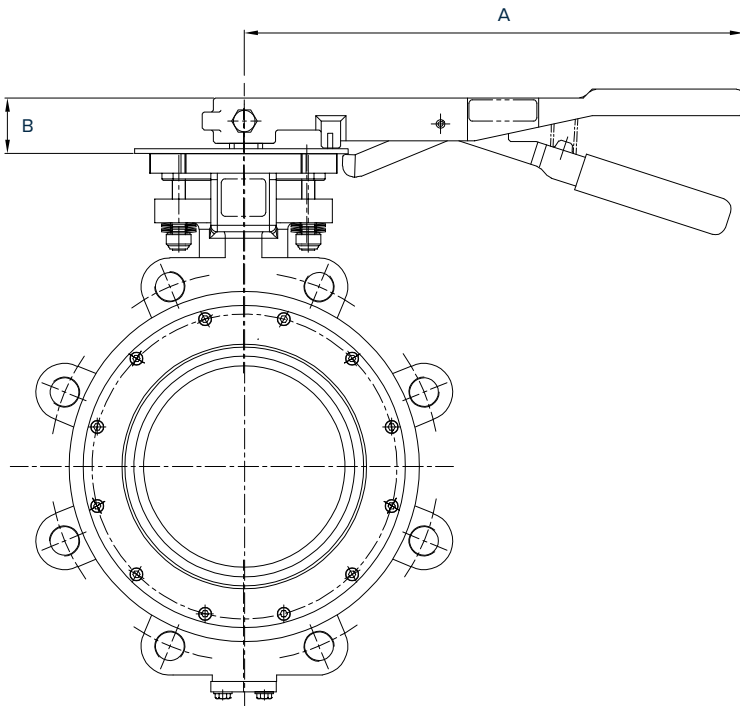

ASME CLASS 150 WAFER AND LUG

Valve Size (Inches)	A	B
2	11.02	1.12
2-1/2	11.02	1.12
3	11.02	1.12
4	11.02	1.12
5	15.75	1.84
6	15.75	1.84

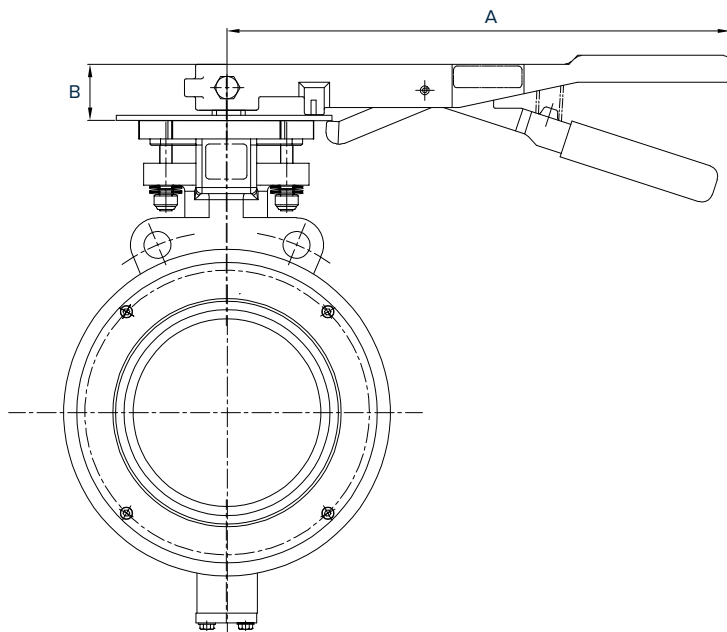

ASME CLASS 300 WAFER AND LUG

Valve Size (Inches)	A	B
2	11.02	1.26
2-1/2	11.02	1.26
3	11.02	1.26
4	15.75	1.85

# FIGURE HPA BUTTERFLY VALVES



## HIGH-PERFORMANCE BUTTERFLY VALVE

### ASME CLASS 150

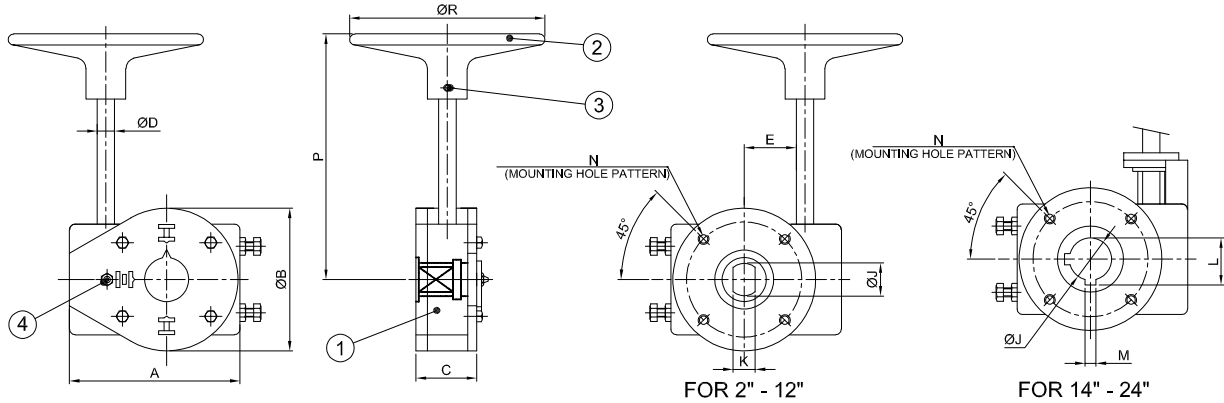

#### PARTS LIST

No.	Part Name	Material Specification	Qty.
1	Gear Operator	As per assembly	01
1a	Gear Housing	ASTM A48 30A	
1b	Gear Housing Cover	ASTM A48 30A	
1c	Worm Wheel	ASTM A536 70-50-05	
1d	Worm	SAE 1040 / SAE 4140	
1e	Input Shaft	SAE 1040 / SAE 4140	
2	Conical Hand Wheel	ASTM A106 GR. B	01
3	Spring Dowel Pin	Spring Steel	01
4	Grease Nipple	Carbon Steel	01

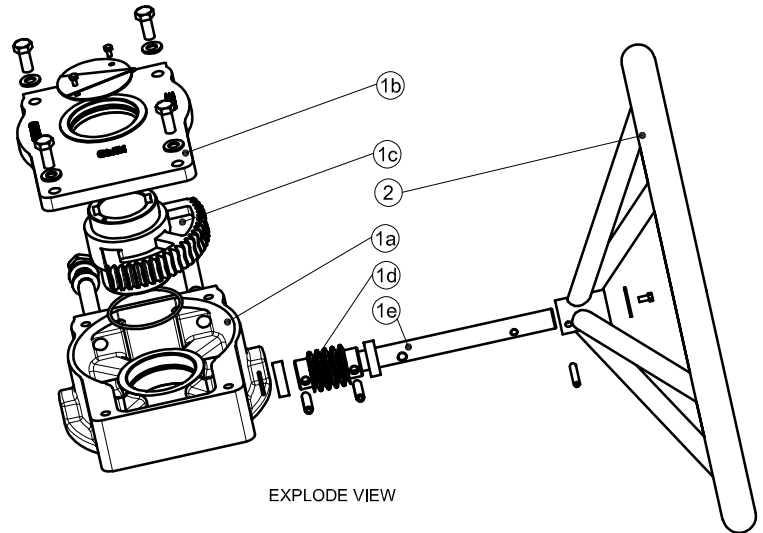

#### DIMENSIONS (INCHES)

Valve Size	Ratio	Model	Gear Output Torque (lbs-in)	Mech. Adv.	A	ØB	C	E	ØD	ØJ	K	L	M	N (Mounting Holes Pattern)				P	ØR	WT. (lbs)
														BC	Holes	Threading	Depth			
2-DN 6	31:1	EG-250	2212	8	4.01	3.5	2.01	1.73	0.5	0.98	0.75	-	-	2.76	04	5/16"-18 UNC	0.47	7.08	7.87	5.3
8-10	40:1	EG-700	6195	10	5.60	4.97	2.91	2.60	0.79	1.18	0.87	-	-	4.92	04	1/2"-13 UNC	0.71	11.1	11.81	15.4
12	40:1	EG-700	6195	10	5.60	4.97	2.91	2.60	0.79	1.38	0.94	-	-	4.92	04	1/2"-13 UNC	0.71	11.1	11.81	15.4
14	65:1	EG1K5	13276	14	7.24	6.30	3.13	3.19	0.79	1.57	-	1.70	0.47	5.51	04	5/8"-11 UNC	0.94	12.28	19.69	26.5
16	60:1	EG2K	17700	16	8.42	6.93	3.77	3.66	0.87	1.97	-	2.14	0.47	6.5	04	3/4"-10 UNC	1.02	16.73	19.69	33.1
18	80:1	EG3K	26552	22	9.26	9.29	4.33	4.72	0.98	2.17	-	2.33	0.63	6.5	04	3/4"-10 UNC	1.18	14.13	19.69	55.1
20	80:1	EG3K	26552	22	9.26	9.29	4.33	4.72	0.98	2.36	-	2.54	0.71	6.5	04	3/4"-10 UNC	1.02	19.45	17.72	55.1
24	220:1	EG4K5	39828	50	9.25	11.81	4.33	7.02	0.79	2.75	-	2.95	0.79	10	08	5/8"-11 UNC	0.94	16.18	19.69	88.2



# FIGURE HPA BUTTERFLY VALVES



## HIGH-PERFORMANCE BUTTERFLY VALVE

### ASME CLASS 300

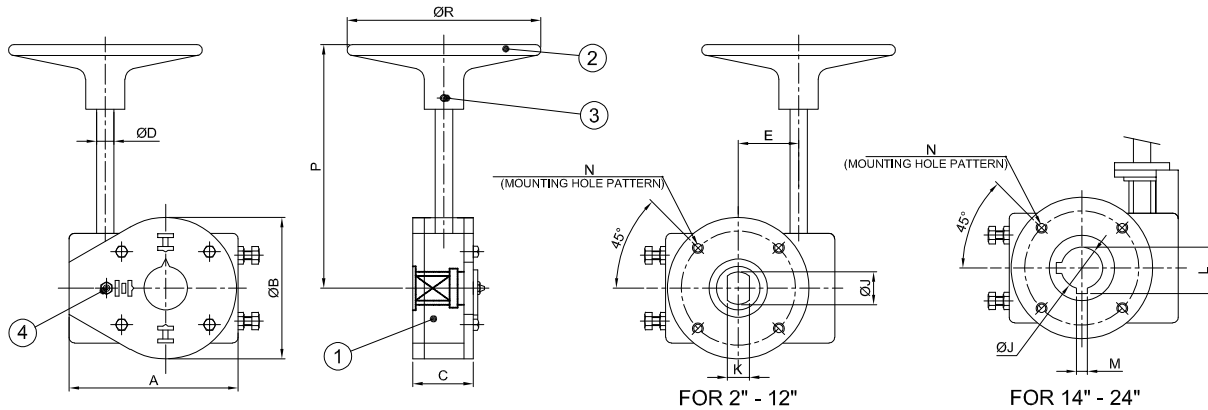

### PARTS LIST

No.	Part Name	Material Specification	Qty.
1	Gear Operator	As per assembly	01
1a	Gear Housing	ASTM A48 30A	
1b	Gear Housing Cover	ASTM A48 30A	
1c	Worm Wheel	ASTM A536 70-50-05	
1d	Worm	SAE 1040 / SAE 4140	
1e	Input Shaft	SAE 1040 / SAE 4140	
2	Conical Hand Wheel	ASTM A106 GR. B	01
3	Spring Dowel Pin	Spring Steel	01
4	Grease Nipple	Carbon Steel	01

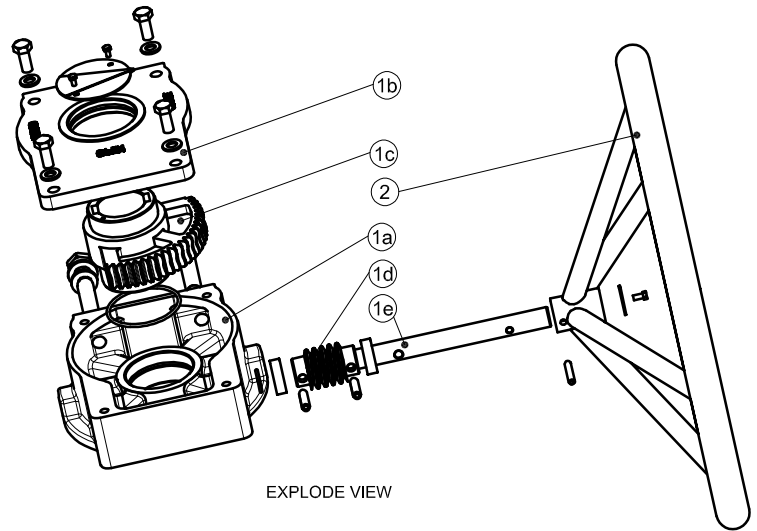

### DIMENSIONS (INCHES)

Valve Size	Ratio	Model	Gear Output Torque (lbs-in)	Mech. Adv.	A	ØB	C	E	ØD	ØJ	K	L	M	N (Mounting Holes Pattern)				P	ØR	WT. (lbs)
														BC	Holes	Threading	Depth			
2-DN 4	31:1	EG-250	2212	8	4.01	3.5	2.01	1.73	0.5	0.98	0.75	-	-	2.76	04	5/16"-18 UNC	0.47	7.08	7.87	5.3
5	40:1	EG-500	4425	10	5.35	4.25	2.54	2.13	0.59	0.75	0.51	-	-	4.02	04	3/6"-16 UNC	0.59	9.84	9.84	11.02
6	40:1	EG-500	4425	10	5.35	4.25	2.54	2.13	0.59	0.87	0.63	-	-	4.02	04	3/8"-16 UNC	0.59	9.84	9.84	11.02
8	44:1	EG 1K	8851	12	7.08	5.59	3.34	2.87	0.79	1.18	0.87	-	-	4.92	04	1/2"-13 UNC	0.71	13.19	17.72	22.04
10	65:1	EG1K5	13276	14	7.24	6.30	3.12	3.19	0.79	1.38	0.94	-	-	4.92	04	1/2"-13 UNC	0.71	11.97	17.72	26.45
12	60:1	EG2K	17701	16	8.43	6.93	3.78	3.66	0.87	1.57	1.14	-	-	6.5	04	3/4"-10 UNC	1.02	16.73	19.69	33.1
14	220:1	EG4K5	39828	50	9.25	9.29	4.33	7.03	0.79	2.17	-	2.33	0.63	6.5	04	3/4"-10 UNC	1.18	15.59	23.62	79.36
16	220:1	EG4K5	39828	50	9.25	9.29	4.33	7.01	0.79	2.17	-	2.33	0.63	6.5	04	3/4"-10 UNC	1.18	16.73	23.62	79.3
18	292:1	EG 6K5	57530	65	10.43	11.81	4.47	7.74	0.79	2.76	-	2.95	0.79	10	08	5/8"-11 UNC	0.94	16.73	23.62	103.6
20	300:1	EG 10K	88507.5	75	13.23	14.84	5.98	9.52	0.79	3.15	-	3.36	0.87	10	08	5/8"-11 UNC	0.94	17.83	23.62	181
24	300:1	EG 10K	88507.5	75	13.23	14.84	5.98	9.52	0.79	3.94	-	4.19	1.10	11.73	08	3/4"-10 UNC	0.94	17.83	23.62	181

# FIGURE HPA BUTTERFLY VALVES



## HIGH-PERFORMANCE BUTTERFLY VALVE

### DOUBLE OFFSET DESIGN

The valve is designed with two offsets. The first offset is between the seat sealing surface and the centerline of the valve stem, putting the stem behind the sealing surface. Since the stem does not penetrate the sealing surface, there is a complete, uninterrupted 360° seat seal. The second offset is between the centerline of the valve stem and the centerline of the valve port. This double offset creates an eccentric seating action that reduces seat wear and torque. The disc cams into the seat for a bubble-tight shutoff. The cam action is improved by the conical angle of the valve disc.

### DOUBLE OFFSET

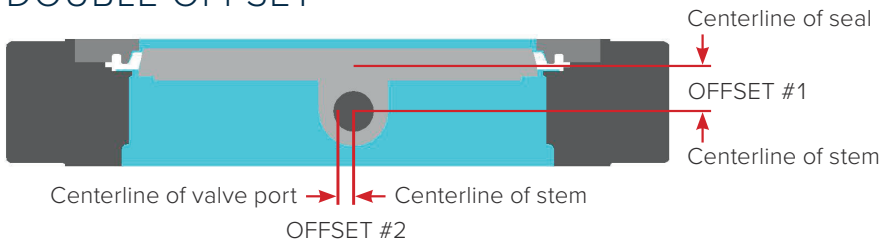

### CAM ACTION

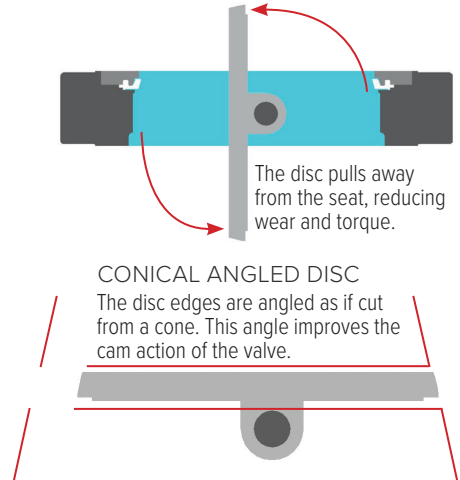

HyperSeat is an engineered fluorocarbon polymer that is rated for 500° F at 285 psi. Its superior ability to handle aggressive fluids at high pressures is recommended for extended service in hostile environments involving chemical, thermal and mechanical stress. HyperSeat has excellent thermal stability and is ideal for steam, hot gases and a variety of process chemicals where service can also be subject to pressure cycling.

## PRESSURE TEMPERATURE RATINGS

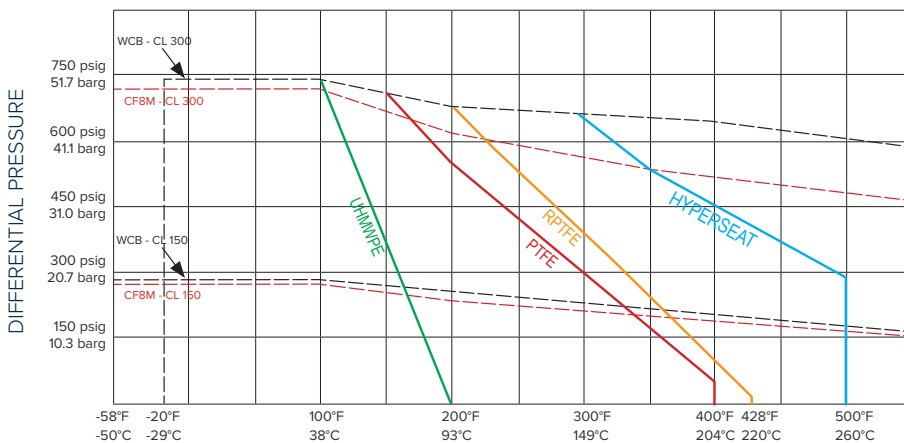

### TEMPERATURE LIMITS

		Lower Limit	Upper Limit
		Deg F	Deg F
Body	WCB	-20	800
	CF8M	-320	1000
Seat	PTFE	-58	400
	RPTFE	-58	428
	HYPERSEAT	-58	500
	UHMWPE	-20	200

Pressure-temperature rating shall be lesser of the shell or seat rating

# FIGURE HPA BUTTERFLY VALVES



## HIGH-PERFORMANCE BUTTERFLY VALVE

### Cv (FLOW COEFFICIENTS)

Cv values indicated below are obtained from CFD analysis. As the calculations are software based, accuracy is +/- 10%.

#### ASME CLASS 150 (INCHES)

Disc Position	Value Size 150#													
Degrees	2	2-1/2	3	4	5	6	8	10	12	14	16	18	20	24
10	2	3	4	5	5	6	25	55	82	130	234	268	291	694
20	10	12	18	30	46	85	182	350	508	552	905	1044	1326	2250
30	22	30	42	77	117	192	352	658	818	954	1465	1554	2012	3499
40	38	50	70	131	191	303	521	964	1230	1435	2025	2340	3030	5050
50	54	66	99	195	264	432	750	1314	1783	2087	2824	3440	4398	7078
60	62	74	133	270	345	560	1059	1782	2531	2975	3900	4980	6247	9951
70	68	80	158	326	438	733	1440	2415	3539	4147	5520	7232	8743	13427
80	70	88	163	361	480	898	1919	3095	4568	5537	7432	10230	11880	16559
90	72	90	167	370	496	948	2069	3341	4817	5805	7808	11170	12609	17105

#### ASME CLASS 300 (INCHES)

Disc Position	Value Size 300#													
Degrees	2	2-1/2	3	4	5	6	8	10	12	14	16	18	20	24
10	2	3	4	6	8	12	15	42	65	115	190	340	525	740
20	4	7	18	31	35	88	157	274	434	538	689	893	1143	1923
30	13	22	42	75	101	182	335	547	805	985	1362	1652	2175	3359
40	24	38	71	114	166	285	506	843	1211	1455	1985	2437	3247	4889
50	36	46	99	157	229	406	716	1224	1731	1997	2697	3410	4370	6637
60	48	52	131	224	294	561	999	1701	2398	2558	3552	4399	5655	8492
70	52	54	158	286	376	758	1358	2305	3264	3288	4569	5575	6779	10544
80	55	56	163	367	427	954	1731	2937	3699	3736	5589	6634	7416	11748
90	58	65	164	383	435	972	1820	3039	3992	4001	5764	6729	7595	12122

The size of butterfly valve used for control purposes should be calculated on the basis of the operating characteristics. In order to achieve optimum control, the flow coefficient (Cv) of a valve needs to be considered. Cv is the volume of water in U.S. gallons per minute that passes through the valve at a pressure drop of 1 psi at 68°F. Flow for a given Cv is typically calculated from the following formula.

Where:

- Q = Valve flow rate in gallons per minute (US GPM)
- ΔP = Pounds per square inch (psi) pressure drop across valve
- 62.4 = Conversion factor for fluids computed in relation to water
- D = Density of fluids in pounds per cubic foot

$$Q = Cv \times \sqrt{\frac{\Delta P \times 62.4}{D}}$$

# FIGURE HPA BUTTERFLY VALVES



## HIGH-PERFORMANCE BUTTERFLY VALVE

### TORQUE DATA ASME CLASS 150

#### SOFT SEAT

Valve Size		Differential Pressure (ΔP)				
		50 psi	100 psi	150 psi	230 psi	285 psi
Inch	DN	Preferred Flow Direction				
2	50	212	230	239	248	257
2-1/2	65	239	248	257	274	283
3	80	283	292	301	327	354
4	100	381	407	434	469	602
5	125	522	575	620	690	735
6	150	779	841	920	1027	1097
8	200	1310	1434	1549	1761	1894
10	250	1708	1938	2160	2505	2788
12	300	2080	2555	2974	3655	4116
14	350	3443	4266	5125	6505	7399
16	400	4390	5470	6585	8284	9523
18	450	5718	7151	8550	10833	12471
20	500	7629	9621	11471	14719	16790
24	600	11550	14586	17772	22640	26181
26	650	14135	17259	19560	23100	28057
28	700	15533	19029	22038	25048	29739
30	750	21198	25773	30349	37669	42705
32	800	27428	33297	40085	48290	55981
36	900	34208	42147	50086	62787	71523

#### FIRE SAFE SEAT

Valve Size		Differential Pressure (ΔP)				
		50 psi	100 psi	150 psi	230 psi	285 psi
Inch	DN	Preferred Flow Direction				
2	50	460	478	496	522	540
2-1/2	65	478	504	513	540	558
3	80	611	628	646	682	708
4	100	752	797	832	894	947
5	125	850	920	1000	1124	1213
6	150	1425	1549	1682	1885	2000
8	200	2337	2593	2788	3142	3425
10	250	3523	3921	4372	5063	5558
12	300	5248	6036	6797	7930	8824
14	350	6231	7143	8010	9559	10532
16	400	7187	8355	9683	11621	13055
18	450	9152	11409	13905	17524	20224
20	500	12949	16445	19817	25632	29349
24	600	20392	24109	28075	34394	38253
26	650	23181	28305	32079	37885	46013
28	700	25474	31208	36143	41078	48771
30	750	34764	42268	49773	61777	70036
32	800	44983	54606	65739	79195	91809
36	900	56101	69122	82142	102971	117298

#### NOTE:

- Flow from retainer side is the preferred flow direction. Flow from stem side is non-preferred flow direction. Arrow on valve body indicates the preferred flow direction.
- BTO-Break to Open; RTO-Run to Open; ETO-End to Open; BTC-Break to Close; RTC-Run to Close; ETC-End to Close.
- Above mentioned tabulated torque values are BTO and ETC for preferred flow direction.
- RTO, ETO, BTC and RTC = 40% of the above tabulated values for preferred direction.
- For non-preferred flow direction torque values of soft seat:
  - 2"–8" Multiply preferred values by 1.12
  - 10"–12" Multiply preferred values by 1.20
  - 14"–24" Multiply preferred values by 1.24
  - 26"–48" Multiply preferred values by 1.30
- For non-preferred flow direction torque values of fire safe seat and metal seat, multiply preferred values by 1.25.
- For actuator sizing, the minimum valve differential pressure shall be 50 psi. For differential pressure above 50 psi, the intermediated values to be interpolated. For gear operator sizing, the full rated torque to be considered.
- The published torque values are without factor of safety. The following factor of safety shall be considered for operator sizing:
  - Clean service (liquid, steam, clean gas and non-abrasive) = 1.3
  - High solids slurry = 1.5
  - Dry gas = 1.7

# FIGURE HPA BUTTERFLY VALVES



## HIGH-PERFORMANCE BUTTERFLY VALVE

### TORQUE DATA ASME CLASS 300

#### SOFT SEAT

Valve Size		Differential Pressure ( $\Delta P$ )				
		150 psi	285 psi	360 psi	580 psi	740 psi
Inch	DN	Preferred Flow Direction				
2	50	239	257	283	354	372
2-1/2	65	257	283	301	372	416
3	80	301	354	389	478	531
4	100	434	602	655	841	956
5	125	779	982	1089	1425	1646
6	150	1062	1363	1549	2071	2434
8	200	2018	2655	3018	4062	4824
10	250	2992	4080	4691	6470	7753
12	300	4186	5656	6426	8868	10524
14	350	6408	9364	11134	15993	19419
16	400	7780	11240	13205	19303	23410
18	450	10054	14621	17126	24658	29836
20	500	13285	19392	23056	33288	40616
24	600	18117	26366	30845	45148	54503

#### FIRE SAFE SEAT

Valve Size		Differential Pressure ( $\Delta P$ )				
		150 psi	285 psi	360 psi	580 psi	740 psi
Inch	DN	Preferred Flow Direction				
2	50	496	540	558	593	620
2-1/2	65	513	558	584	620	655
3	80	646	708	726	770	814
4	100	832	947	1071	1275	1434
5	125	1097	1283	1390	1717	1921
6	150	1814	2186	2399	3009	3443
8	200	2983	3647	4009	5098	5833
10	250	4478	5399	5921	7417	8532
12	300	7302	9541	10639	14303	16816
14	350	8196	10683	12055	16170	19003
16	400	9939	13409	15312	21295	25402
18	450	15285	22587	26738	38811	47431
20	500	21286	32031	37589	55618	67089
24	600	34199	50494	59318	85923	104129

#### NOTE:

- Flow from retainer side is the preferred flow direction. Flow from stem side is non-preferred flow direction. Arrow on valve body indicates the preferred flow direction.
- BTO-Break to Open; RTO-Run to Open; ETO-End to Open; BTC-Break to Close; RTC-Run to Close; ETC-End to Close.
- Above mentioned tabulated torque values are BTO and ETC for preferred flow direction.
- RTO, ETO, BTC and RTC = 40% of the above tabulated values for preferred direction.
- For non-preferred flow direction torque values of soft seat, fire safe seat and metal seat, multiply preferred values by 1.25.
- For actuator sizing, the minimum valve differential pressure shall be 150 psi. For differential pressure above 150 psi, the intermediated values to be interpolated. For gear operator sizing, the full rated torque to be considered.
- The published torque values are without factor of safety. The following factor of safety shall be considered for operator sizing:  
Clean service (liquid, steam, clean gas and non-abrasive) = 1.3  
High solids slurry = 1.5  
Dry gas = 1.7

# FIGURE HPA BUTTERFLY VALVES



## HIGH-PERFORMANCE BUTTERFLY VALVE

### FIGURE NUMBER MATRIX

FNW HPA						
CLASS	CONNECTION	BODY MATERIAL	SEAT	OPERATOR	SIZE	
1 = 150# 3 = 300#	W = WAFER L = LUG	C = WCB - CARBON STEEL S = CF8M - STAINLESS STEEL	T = HYPERSEAT TFS = FIRESAFE	L = LEVER (STANDARD 2"-4")* G = GEAR (STANDARD 6"-24")* B = BARE STEM	2 = K 2-1/2 = L 3 = M 4 = P 5 = S 6 = U 8 = X 10 = 10 12 = 12	14 = 14 16 = 16 18 = 18 20 = 20 24 = 24 28 = 28 30 = 30 36 = 36
				*Lever available on 6" *Gear operator available on 2"-4"		

**Example:** Part Number for a Class 150#, Wafer Style Connection, Stainless Steel Body Material, Hyperseat, Gear Operator, 10" Size: **FNWHPA1WSTG10**

Other body and seat materials available

### REPLACEMENT LEVER HANDLES

(ORDER SEPARATELY)

FNW HPA	Lever Handle	Size
	<i>Level Handle</i>	<i>Size Code</i>
	LH	2-1/2-4 = LMP
		5-6 = SU





Gate valves are bi-directional valves ideally suited for on-off duties. OMB produces various types both with parallel face gates or with wedge gates. These valves have a very low resistance to flow, which in the case of parallel gate valves approaches that of a straight pipe. They are used for duties with high pressure fluids due to the fact that upstream pressure helps the sealing between gate and seat.

OMB takes great care to study finish of seating surfaces to guarantee their minimum wear under high pressures. Gate valves are supplied in various models to cover the most different and delicate services. The main characteristics of each type are described on pages 16 to 23.

**Figure # is identified in each table as:**

STANDARD PORT	810	-
FULL PORT	610	1/4
		mm

CLASS	CONNECTION	PORT	STANDARD	SCREW & YOKE	ENDS	SERVICE	PAGE	OMB FIG.
800	Bolted bonnet	Regular	ISO15761	Outside	Threaded and Socket Weld Ends	-	17	810
800	Bolted bonnet	Full	ISO15761	Outside	Threaded and Socket Weld Ends	-	17	610
800	Welded Bonnet	Regular	ISO15761	Outside	Threaded and Socket Weld Ends	-	17	L810
800	Welded Bonnet	Full	ISO15761	Outside	Threaded and Socket Weld Ends	-	17	L610
800	Bolted bonnet	Regular	ISO15761	Inside	Threaded and Socket Weld Ends	-	17	800
800	Bolted bonnet	Full	ISO15761	Inside	Threaded and Socket Weld Ends	-	17	600
800	Welded Bonnet	Regular	ISO15761	Inside	Threaded and Socket Weld Ends	-	17	L800
800	Welded Bonnet	Full	ISO15761	Inside	Threaded and Socket Weld Ends	-	17	L600
1500	Bolted bonnet	Regular	ISO15761	Outside	Threaded and Socket Weld Ends	-	18	R910
1500	Bolted bonnet	Full	ISO15761	Outside	Threaded and Socket Weld Ends	-	18	910
1500	Welded Bonnet	Regular	ISO15761	Outside	Threaded and Socket Weld Ends	-	18	LR910
1500	Welded Bonnet	Full	ISO15761	Outside	Threaded and Socket Weld Ends	-	18	L910
1500	Ring Joint BB	Full	ISO15761	Outside	Threaded and Socket Weld Ends	-	18	RJ910
1500	Ring Joint BB	Full	ISO15761	Outside	Butt Weld B16.10	-	18	BW9-RJ910
2500	Ring Joint BB	Full	ANSI B16.34	Outside	Threaded and Socket Weld Ends	-	19	RJ2510
2500	Ring Joint BB	Full	ANSI B16.34	Outside	Butt Weld and Clamp Ends	-	19	BW25-RJ2510
2500	Welded Bonnet	Full	ANSI B16.34	Outside	Threaded and Socket Weld Ends	-	19	L2510
2500	Welded Bonnet	Full	ANSI B16.34	Outside	Butt Weld and Clamp Ends	-	19	BW25-L2510
800	Welded Bonnet	Regular	ISO15761	Outside	Extended Body - Male Threaded	-	20	MLA-810
800	Welded Bonnet	Regular	ISO15761	Outside	Extended Body - Male Socket	-	20	MLB-810
800	Welded Bonnet	Regular	ISO15761	Outside	Extended Body - BW	-	20	MLC-810
800	Bolted bonnet	Regular	ISO15761	Outside	Extended Body - Male Threaded	-	20	MA-810
800	Bolted bonnet	Regular	ISO15761	Outside	Extended Body - Male Socket	-	20	MB-810
800	Bolted bonnet	Regular	ISO15761	Outside	Extended Body - BW	-	20	MC-810
800	Welded Bonnet	Regular	ISO15761	Outside	Extended Body - Reinforced - BW	-	20	MLW-810
800	Welded Bonnet	Regular	ISO15761	Outside	Extended Body - Reinforced - Male SW	-	20	MLD-810
800	Bolted bonnet	Regular	ISO15761	Outside	Extended Body - Reinforced - BW	-	20	MW-810
800	Bolted bonnet	Regular	ISO15761	Outside	Extended Body - Reinforced - Male SW	-	20	MD-810
1500	Welded Bonnet	Regular	ISO15761	Outside	Extended Body - Male Threaded	-	20	MLA-R910
1500	Welded Bonnet	Regular	ISO15761	Outside	Extended Body - Male Socket	-	20	MLB-R910
1500	Welded Bonnet	Regular	ISO15761	Outside	Extended Body - BW	-	20	MLC-R910
1500	Bolted bonnet	Regular	ISO15761	Outside	Extended Body - Male Threaded	-	20	MA-R910
1500	Bolted bonnet	Regular	ISO15761	Outside	Extended Body - Male Socket	-	20	MB-R910
1500	Bolted bonnet	Regular	ISO15761	Outside	Extended Body - BW	-	20	MC-R910
1500	Welded Bonnet	Regular	ISO15761	Outside	Extended Body - Reinforced - BW	-	20	MLW-R910
1500	Welded Bonnet	Regular	ISO15761	Outside	Extended Body - Reinforced - Male SW	-	20	MLD-R910
1500	Bolted bonnet	Regular	ISO15761	Outside	Extended Body - Reinforced - BW	-	20	MW-R910
1500	Bolted bonnet	Regular	ISO15761	Outside	Extended Body - Reinforced - Male SW	-	20	MD-R910
150	Bolted bonnet	Regular	ISO15761	Outside	Integral Flanged to ASME B16.5	-	21	F1-810
300	Bolted bonnet	Regular	ISO15761	Outside	Integral Flanged to ASME B16.5	-	21	F3-810
600	Bolted bonnet	Regular	ISO15761	Outside	Integral Flanged to ASME B16.5	-	21	F6-810
150	Bolted bonnet	Full	ISO15761	Outside	Integral Flanged to ASME B16.5	-	21	F1-610
300	Bolted bonnet	Full	ISO15761	Outside	Integral Flanged to ASME B16.5	-	21	F3-610
600	Bolted bonnet	Full	ISO15761	Outside	Integral Flanged to ASME B16.5	-	21	F6-610
1500	Ring Joint BB	Full	ISO15761	Outside	Integral Flanged to ASME B16.5	-	21	F9-RJ910
2500	Ring Joint BB	Full	ISO15761	Outside	Integral Flanged to ASME B16.5	-	21	F25-RJ2510
800	Bolted bonnet	Regular	ISO15761	Outside	Threaded and Socket Weld Ends	Sour Service	22	SS810
800	Welded Bonnet	Regular	ISO15761	Outside	Threaded and Socket Weld Ends	Alkilation	22	AS-L810
800	Welded Bonnet	Regular	ISO15761	Outside	Threaded and Socket Weld Ends	Vacuum	22	VS-L810
800	Bolted bonnet	Regular	ISO15761	Outside	Threaded and Socket Weld Ends	Chlorine	22	CS-810



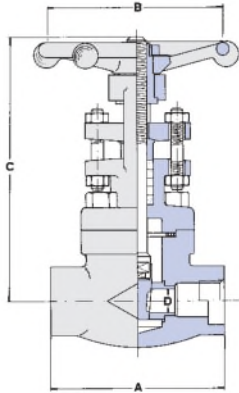

RATINGS: Carbon Steel - 1975 p.s.i. @ 100°F

## CLASS 800

**BOLTED BONNET - STANDART PORT TO API602/ISO 15761 - FULL PORT TO BS 5352**  
Outside Screw & Yoke - Threaded and Socket Weld Ends

STANDARD PORT	810	-	1/2	3/4	1	1.1/4	1.1/2	2	-						
FULL PORT	610	1/4	3/8	1/2	3/4	1	1.1/4	1.1/2	2						
	mm in.		mm in.		mm in.		mm in.		mm in.		mm in.				
End to End	<b>A</b>	80	3.14	80	3.14	90	3.54	110	4.33	127	5.00	127	5.00	150	5.90
Handwheel	<b>B</b>	80	3.14	80	3.14	80	3.14	110	4.33	110	4.33	130	5.11	130	5.11
Center to Top Open	<b>C</b>	148	5.86	148	5.86	163	6.41	178	7.00	210	8.26	243	9.56	262	10.3
Dia. of Port	<b>D</b>	8	0.31	9.6	0.38	14	0.55	18	0.70	24	0.94	30	1.18	37	1.45
Approx. Weight	<b>Kg / Lb</b>	1.6	3.5	1.6	3.5	2.2	4.8	3.5	7.7	5	11	6.5	14.3	9	19.8

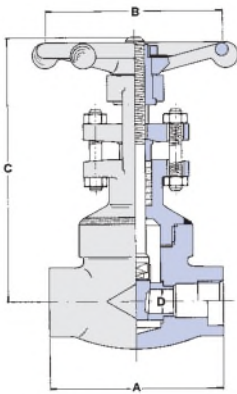

RATINGS: Carbon Steel - 1975 p.s.i. @ 100°F

## CLASS 800

**BOLTED BONNET - STANDART PORT TO API602/ISO 15761 - FULL PORT TO BS 5352**  
Outside Screw & Yoke - Threaded and Socket Weld Ends

STANDARD PORT	L810	-	1/2	3/4	1	1.1/4	1.1/2	2	-						
FULL PORT	L610	1/4	3/8	1/2	3/4	1	1.1/4	1.1/2	2						
	mm in.		mm in.		mm in.		mm in.		mm in.		mm in.				
End to End	<b>A</b>	80	3.14	80	3.14	90	3.54	110	4.33	127	5.00	127	5.00	150	5.90
Handwheel	<b>B</b>	80	3.14	80	3.14	80	3.14	110	4.33	110	4.33	130	5.11	130	5.11
Center to Top Open	<b>C</b>	148	5.86	148	5.86	163	6.41	178	7.00	210	8.26	243	9.56	262	10.3
Dia. of Port	<b>D</b>	8	0.31	9.6	0.38	14	0.55	18	0.70	24	0.94	30	1.18	37	1.45
Approx. Weight	<b>Kg / Lb</b>	1.6	3.5	1.6	3.5	2.2	4.8	3.5	7.7	5	11	6.3	13.8	8	17.6

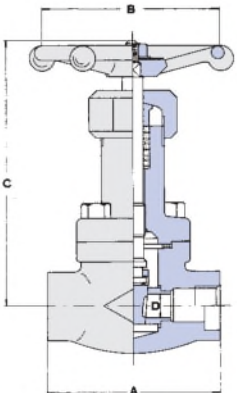

RATINGS: Carbon Steel - 1975 p.s.i. @ 100°F

## CLASS 800

**BOLTED BONNET - STANDART PORT TO API602/ISO 15761 - FULL PORT TO BS 5352**  
Inside Screw & Yoke - Threaded and Socket Weld Ends

STANDARD PORT	800	-	1/2	3/4	1	1.1/4	1.1/2	2	-						
FULL PORT	600	1/4	3/8	1/2	3/4	1	1.1/4	1.1/2	2						
	mm in.		mm in.		mm in.		mm in.		mm in.		mm in.				
End to End	<b>A</b>	80	3.14	80	3.14	90	3.54	110	4.33	127	5.00	127	5.00	150	5.90
Handwheel	<b>B</b>	80	3.14	80	3.14	80	3.14	110	4.33	110	4.33	130	5.11	130	5.11
Center to Top Open	<b>C</b>	148	5.86	148	5.86	175	6.88	212	8.34	235	9.25	287	11.3	327	12.9
Dia. of Port	<b>D</b>	8	0.31	9.6	0.38	14	0.55	18	0.70	24	0.94	30	1.18	37	1.45
Approx. Weight	<b>Kg / Lb</b>	1.5	3.3	1.5	3.3	2	4.4	3	6.6	5.1	11.2	6.7	14.7	9.5	20.9

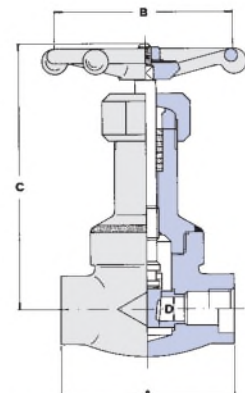

RATINGS: Carbon Steel - 1975 p.s.i. @ 100°F

## CLASS 800

**BOLTED BONNET - STANDART PORT TO API602/ISO 15761 - FULL PORT TO BS 5352**  
Inside Screw & Yoke - Threaded and Socket Weld Ends

STANDARD PORT	L800	-	1/2	3/4	1	1.1/4	1.1/2	2	-						
FULL PORT	L600	1/4	3/8	1/2	3/4	1	1.1/4	1.1/2	2						
	mm in.		mm in.		mm in.		mm in.		mm in.		mm in.				
End to End	<b>A</b>	80	3.14	80	3.14	90	3.54	110	4.33	127	5.00	127	5.00	150	5.90
Handwheel	<b>B</b>	80	3.14	80	3.14	80	3.14	110	4.33	110	4.33	130	5.11	130	5.11
Center to Top Open	<b>C</b>	148	5.86	148	5.86	175	6.88	212	8.34	235	9.25	287	11.3	327	12.9
Dia. of Port	<b>D</b>	8	0.31	9.6	0.38	14	0.55	18	0.70	24	0.94	30	1.18	37	1.45
Approx. Weight	<b>Kg / Lb</b>	1.5	3.3	1.5	3.3	2	4.4	3	6.6	5.1	11.2	6.5	14.3	9	19.8



# PRESSURE SEAL GATE VALVES

CAST, CARBON, STAINLESS STEEL OR ALLOY STEEL

2 - 24" (50 - 600 mm)

ASME CLASSES 600 - 2500

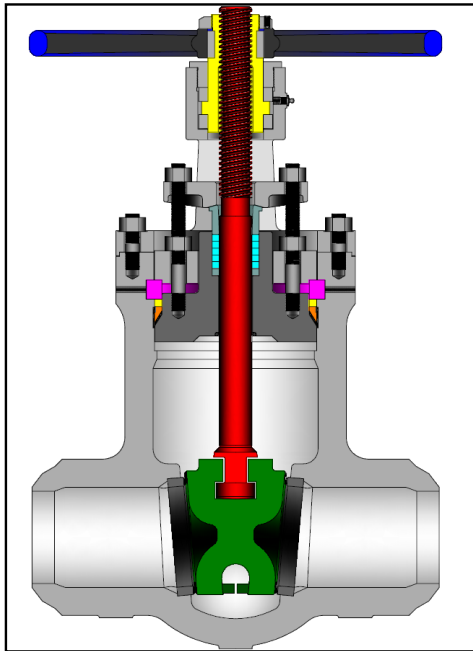

Class	Fig. No.
600	1603
900	1903
1500	1103
2500	1203

### STANDARD MATERIALS (Other materials available)

PART	MATERIALS			
Body	A216 Gr. WCB (STANDARD)	A217 Gr. WC6	A217 Gr. WC9	A217 Gr. C12A
Bonnet	A105	A182 F11	A182 F22	A182 F91
Yokearm	A216 Gr. WCB			
Wedge	A216 WCB + Stellite 6 Faced	A217 WC6 + Stellite 6 Faced	A217 WC9 + Stellite 6 Faced	A217 C12A + Stellite 6 Faced
Seat Ring	Carbon Steel + Stellite 6 Faced	A182 F11 + Stellite 6 Faced	A182 F22 + Stellite 6 Faced	A182 F91 + Stellite 6 Faced
Stem	A182 F6a			
Stem Bushing	A 439 Ductile NI-Resist Gr. D2			
Stem Bushing Lock Nut	Steel			
Gland Flange	A216 Gr. WCB			
Eye Bolt	A193 Gr. B7			
Eye Bolt Nut	A194 Gr. 2H			
Gland	SST 410			
Packing	Graphite			
Packing Washer / Packing Spacer	SST 410			
Protective Ring	SST 410			
Segmental Thrust Ring	SST 410			
Support Plate	Steel			
Gasket	SST 304L			
Hand Wheel	Malleable Iron or Steel			
Hand Wheel Nut	Steel			
Key	Steel			
Lubricant Fitting	Steel			
Bonnet Takeup / Yoke Stud	A193 Gr. B7	A193 Gr. B16		
Bonnet Takeup / Yoke Nut	A194 Gr. 2H	A194 Gr. 7		

### DESIGN FEATURES:

- Flexible Wedge for improved seating and ease of operation, especially in high temperature service. Wedges are accurately guided thru the entire stroke.
- Valves are full port design per ASME B16.34 Table A-1.
- Standard trim is stellite faced seat and disc seat surfaces, and 13% chrome stem (API trim 5). Other trims available on request.
- Seat faces lapped for smooth finish and superior sealing.
- Stems are non-rotating with surface finish to maximize packing seal for low fugitive emissions.
- Yoke arms designed for ease of gear, motor or cylinder actuator adaptation.
- Each valve is shell, seat and backseat pressure tested per industry standard API 598.
- Gland is two piece gland / gland flange design for optimal alignment and uniform packing compression.
- Each valve has a unique certification number that is traceable to the valve certification sheet which includes MTR data, pressure test report, inspection report and certificate of conformance.
- Valve sizes 4" and smaller have bonnet take up ring design instead of support plate design.
- Weld end valves are B16.10 short pattern design. Flanged end valves are available on request and are B16.10 long-pattern design. Weld end valve dimensions given in table on next page.
- Other available options as follows:
  - » Alternate valve materials such as chrome and stainless steel alloys

### Design Specifications

Item	Applicable Specification
Wall thickness	API 600
Pressure - temperature ratings	ASME B16.34
General valve design	ASME B16.34
End to End dimensions	ASME B16.10
Flange design	ASME B16.5
Butt Weld design	ASME B16.25
Materials	ASTM

- » Alternate trim materials
- » Bypass, drain and other auxiliary connections
- » Gear, motor, and cylinder actuators available
- » NACE service
- » Special cleaning for applications such as oxygen or chlorine
- » Other options available as specified

# GATE VALVE DIMENSIONS (CLASSES 600 - 2500)

SIZE in mm	ASME 600					ASME 900					ASME 1500				
	A	B(1)	C(1)	D	E	A	B(1)	C(1)	D	E	A	B(1)	C(1)	D	E
2	7	15.7	18.2	2.00	8	8.5	19.7	22.0	1.87	14	8.5	19.7	22.0	1.87	14
50	178	399	462	51	200	216	499	558	48	356	216	499	558	48	356
2½	8.5	19.6	22.6	2.50	12	10.0	21.5	24.1	2.25	14	10.0	21.5	24.3	2.25	14
65	216	498	573	64	305	254	546	612	57	356	254	545	616	57	356
3	10	20.3	23.7	3.00	12	12.0	22.8	26.1	2.87	14	12.0	23.7	27.1	2.75	16
80	254	516	602	76	305	305	578	664	73	356	305	603	688	70	406
4	12	24.4	29.0	4.00	14	14.0	25.2	29.5	3.87	16	16.0	27.7	31.9	3.62	20
100	305	620	736	102	356	356	640	750	98	406	406	703	811	92	500
6	18	27.6	34.1	6.00	20	20.0	28.7	35.1	5.75	20	22.0	30.2	36.3	5.37	22
150	457	700	865	152	508	508	729	892	146	508	559	768	923	136	560
8	23	32.6	41.2	7.87	20	26.0	33.6	42.0	7.50	25	28.0	34.8	42.6	7.00	28
200	584	828	1047	200	508	660	854	1066	191	640	711	883	1083	178	720
10	28	38.4	49.0	9.75	25	31.0	44.2	53.5	9.37	30	34.0	44.5	53.3	8.75	28
250	711	975	1245	248	640	787	1122	1360	238	762	864	1131	1353	222	710
12	32	44.5	56.9	11.75	28	36.0	59.3	70.4	11.12	30	39.0	50.1	60.5	10.37	30
300	813	1129	1445	298	680	914	1505	1788	282	762	991	1272	1535	263	762
14	35	56.9	62.1	12.87	30	39.0	66.9	79.2	12.25	30	42.0	63.1	74.5	11.37	36
350	889	1445	1577	327	762	991	1700	2011	311	762	1067	1604	1892	289	914
16	39	74.9	14.75	18	43.0	76.1	14.00	24	47.0	76.1	13.00	24			
400	991	1903	375	460	1092	1933	356	610	1194	1933	330	610			
18	43	84.9	16.5	18	48.0	88.7	15.75	24	53.0	84.6	14.62	24			
450	1092	2157	419	460	1219	2255	400	610	1346	2149	371	610			
20	47	86.6	18.25	18	52.0	92.2	17.5	24	58.0	104	16.37	24			
500	1194	2200	464	460	1321	2342	445	610	1473	2626	416	610			
24	55	90.4	22.00	18	61.0	106.0	21.00	24	76.5	138	19.62	24			
600	1397	2295	559	460	1549	2680	533	610	1943	3490	498	610			

(1) Gear operators standard for 16" and up classes 600 to 1500 and 14" and up for class 2500.

SIZE in mm	ASME 2500				
	A	B(1)	C(1)	D	E
2	11.0	18.6	20.5	1.50	12
50	279	473	521	38	300
2½	13.0	22.0	26.1	1.87	18
65	330	558	662	48	457
3	14.5	22.0	26.1	2.25	18
80	368	558	662	57	457
4	18.0	28.2	32.0	2.87	20
100	457	717	812	73	508
6	24.0	31.4	36.5	4.37	24
150	610	798	928	111	610
8	30.0	39.2	47.2	5.75	24
200	762	997	1200	146	610
10	36.0	45.3	52.6	7.25	30
250	914	1151	1335	184	762
12	41.0	52.7	66.7	8.62	36
300	1041	1339	1695	219	914
14	44.0	74.2	9.50	24	
350	1118	1885	241	610	
16	49.0	77.0	10.87	24	
400	1245	1956	276	610	
18	55.0	79.9	12.25	32	
450	1397	2030	311	800	

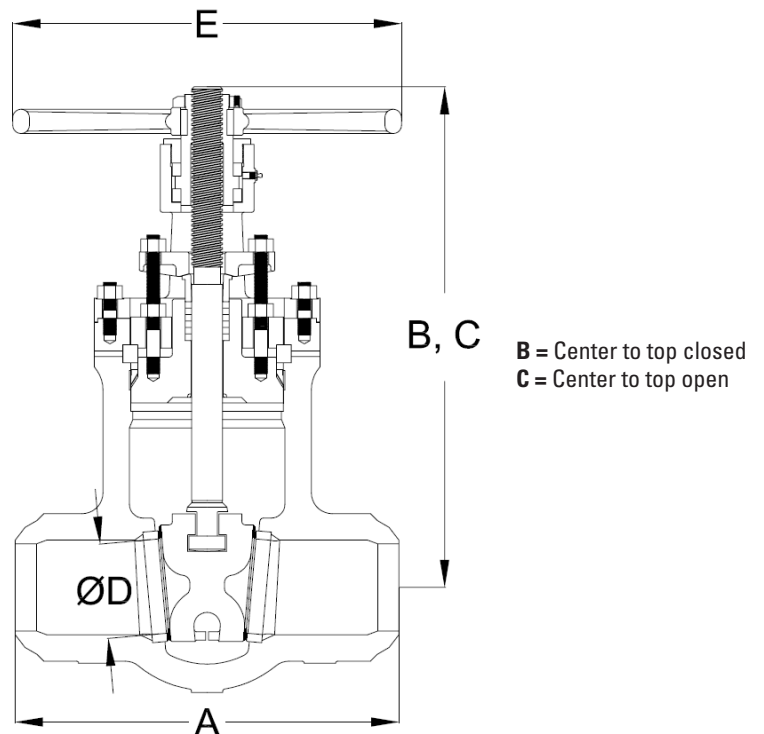

# PRESSURE SEAL GATE VALVES

CAST CARBON, STAINLESS STEEL OR ALLOY STEEL

2 - 24" (50 - 600 mm)

ASME CLASSES 600 - 2500

SIZE	ASME 600					ASME 900					ASME 1500					ASME 2500				
	in mm	F	in mm	WT lb kg	CV	F	in mm	WT lb kg	CV	F	in mm	WT lb kg	CV	F	in mm	WT lb kg	CV			
2	27.5		95		240	30.2		95		210	30.2		95		210	30.6		176		140
50	699		43			766		43			766		43			778		80		
2½	30.2		125		390	30.3		125		310	32.8		135		310	34.6		348		220
65	768		56			769		56			832		61			878		158		
3	32.3		143		560	35.4		154		510	36.9		221		470	34.6		392		310
80	821		65			898		70			937		100			878		178		
4	39.0		181		1000	40.4		229		950	43.9		401		830	43.2		522		520
100	990		82			1025		104			1115		182			1098		237		
6	45.5		364		2400	46.9		518		2200	47.2		760		2000	50.3		772		1300
150	1155		165			1192		235			1199		345			1278		381		
8	54.5		712		4300	56.4		904		3900	57.1		1583		3400	60.2		1852		2300
200	1385		323			1433		410			1449		718			1530		840		
10	65.2		1091		6700	68.2		1820		6200	66.4		2787		5400	72.5		3504		3700
250	1655		495			1733		825			1687		1264			1841		1589		
12	76.6		1616		10000	78.0		2586		9000	78.0		3235		7800	82.6		5420		5400
300	1945		733			1982		1173			1980		1467			2098		2458		
14	84.5		2221		12000	81.5		3421		11000	89.8		5140		9400	94.1		7110		6600
350	2146		1007			2069		1552			2282		2336			2391		3225		
16	94.2		2898		16000	99.4		4291		14000	101.9		6477		12000	111.8		4016		8600
400	2393		1314			2523		1946			2588		2937			2840		4801		
18	105.3		3646		21000	111.5		5164		19000	114.9		7857		16000	114.7		10587		11000
450	2675		1654			2832		2342			2917		3563			2913		4801		
20	116.4		4456		25000	122.3		6005		23000	129.0		9256		20000					
500	2958		2021			3106		2723			3275		4198							
24	141.9		6231		37000	147.5		7463		33000	161.3		11983		29000					
600	3605		2826			3747		3385			4098		5434							

**Note:** Does not include weight of gear.

**WT** = Weight  
**F** = Dismantling Dimension  
**CV** = Flow Coefficient

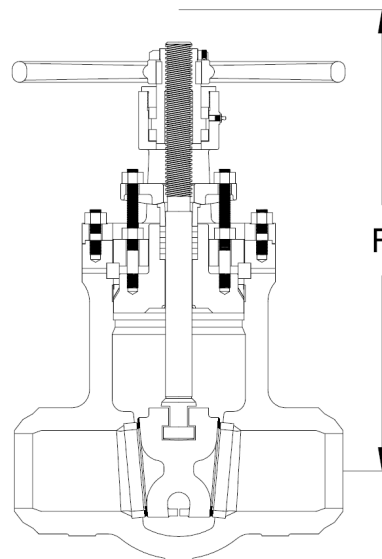

## Forged Gate Valves

### Class 2500/2680 Gate Valve Full Port

Welded Bonnet  
 Outside Screw & Yoke  
 Bolted Gland  
 Solid Hard Faced Wedge  
 Hard Faced Seats  
 ASME B16.34 LTD. Pressure Class

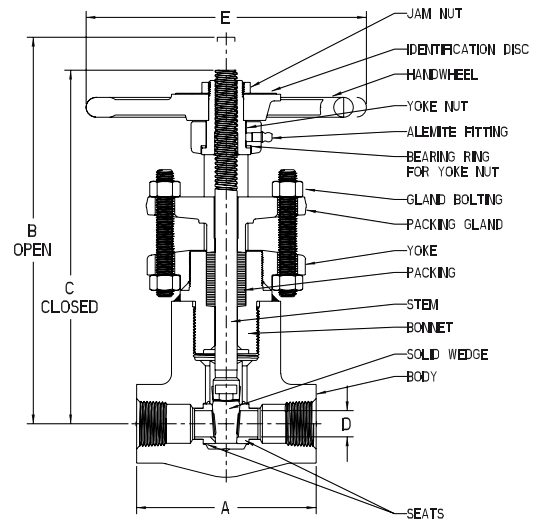

CONNECTION	SERIES	BODY/BONNET	TRIM	RATING		CLASS
Threaded Threaded X Socket Weld TSW	66703	A105	13% Cr.	6250 PSI @ 100 F	430.9 BAR @ 38 C	2500 LTD
	66743	A350 LF2		6250 PSI @ -50 F	430.9 BAR @ -46 C	
	66713	F11, Cl.2(1-1/4 Cr.)		6250 PSI @ 100 F	430.9 BAR @ 38 C	
	66773	F22, Cl.3(2-1/4 Cr.)		6250 PSI @ 100 F	430.9 BAR @ 38 C	
	66791	F91		6250 PSI @ 100 F	430.9 BAR @ 38 C	
Socket Weld	SW66703	A105	13% Cr.	6700 PSI @ 100 F	461.9 BAR @ 38 C	2680 LTD
	SW66743	A350 LF2		6700 PSI @ -50 F	461.9 BAR @ -46 C	
	SW66713	F11, Cl.2(1-1/4 Cr.)		6700 PSI @ 100 F	461.9 BAR @ 38 C	
	SW66773	F22, Cl.3(2-1/4 Cr.)		6700 PSI @ 100 F	461.9 BAR @ 38 C	
	SW66791	F91		6700 PSI @ 100 F	461.9 BAR @ 38 C	

### Dimensions

SIZE			A	B	C	D	E	WEIGHT	Cv
-04	NPS	1/2	4.00	8.84	8.28	.41	5.75	10.0	5.0
	DN	15	102	225	210	10.4	146	4.5	
-05	NPS	3/4	5.12	11.03	10.09	.75	8.00	20.7	17.5
	DN	20	130	280	256	19.1	203	9.4	
-06	NPS	1	5.12	11.03	10.09	.75	8.00	20.3	16.1
	DN	25	130	280	256	19.1	203	9.2	
-08	NPS	1 1/2	8.50	15.86	14.12	1.50	12.00	90.8	109.6
	DN	40	216	403	359	38.1	305	41.2	
-09	NPS	2	8.50	15.86	14.12	1.50	12.00	88.3	100.2
	DN	50	216	403	359	38.1	305	40.1	

# CLIP GATE VALVE

THREADED BONNET, THREADED ENDS

1/4 - 4" (6 - 100 mm) CLASS 150

CAST IRON

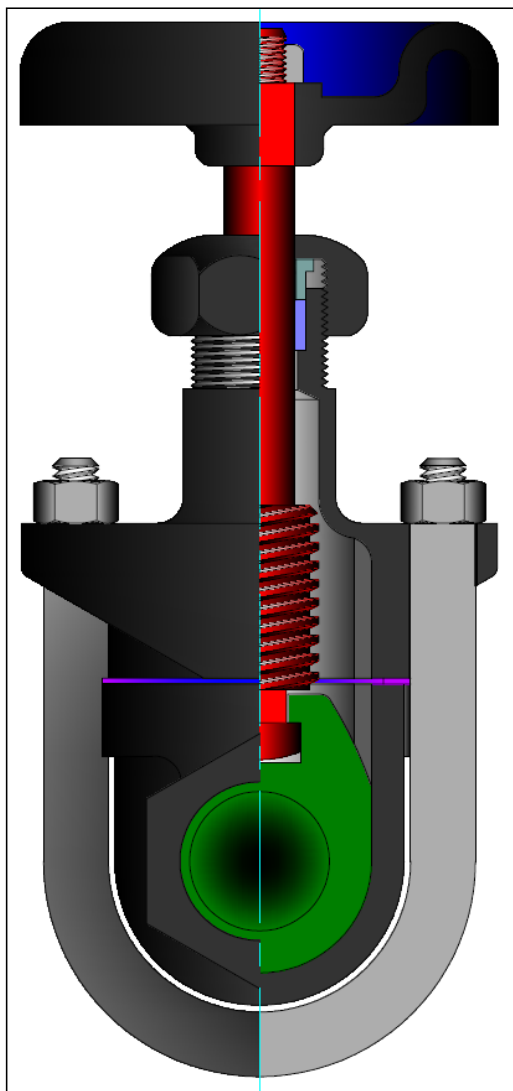

Class	Trim	Fig. No.
125	Bronze	3460
	Iron	3462

## STANDARD MATERIALS

FIGURE		3460	3462
PART		MATERIALS	
Body	1/4" - 1"	A536	
	1 1/4" - 4"	A126-B	
Bonnet	1/4" - 1"	A536	
	1 1/4" - 4"	A126-B	
Wedge	B62	A536	
Stem	B16	A276-410	
Packing Nut	A536		
Gland	B16	A276-410	
Packing	Non-Asbestos		
Gasket	Non-Asbestos		
Hand Wheel	A126-B		
Hand Wheel Nut	A563-A		
U-Bolt	A307-A		
U-Bolt Nut	A563-A		
Name Plate	Aluminum		

## Design Specifications

Item	Applicable Specification
Pressure-Temperature Ratings	MSS SP-70
Thread Design	ASME B1.20.1
Materials	ASTM

## DESIGN FEATURES:

- Seat faces lapped for smooth finish and superior sealing.
- Each valve is shell and seat pressure tested per industry standard MSS SP-70.

# GATE VALVE DIMENSIONS (CLASS 125)

SIZE	FIG 3460 & 3462						
in	A	C	D	E	WT	lb	CV
mm						kg	
¼	2.09	5.0	0.25	2.1	1.5		2.8
6	53	127	6	54	0.7		
3/8	2.09	5.0	0.38	2.1	1.5		7.8
10	53	127	10	54	0.7		
½	2.09	5.0	0.50	2.1	1.5		13.2
13	53	127	13	54	0.7		
¾	2.52	6.2	0.75	2.4	2		30
20	64	158	19	62	0.9		
1	2.63	7.5	1.00	3	3		55
25	67	191	25	75	1.4		
1¼	2.91	9.0	1.25	3	5		87
32	74	229	32	75	2.3		
1½	3.14	9.1	1.50	3.8	6.5		129
40	80	232	38	95	2.9		
2	3.89	11.6	2.00	4	10		240
50	99	294	51	101	4.5		
2½	4.59	12.9	2.50	4.8	16		385
65	117	327	64	121	7.3		
3	4.92	14.8	3.00	6	24		555
75	125	375	76	152	11		

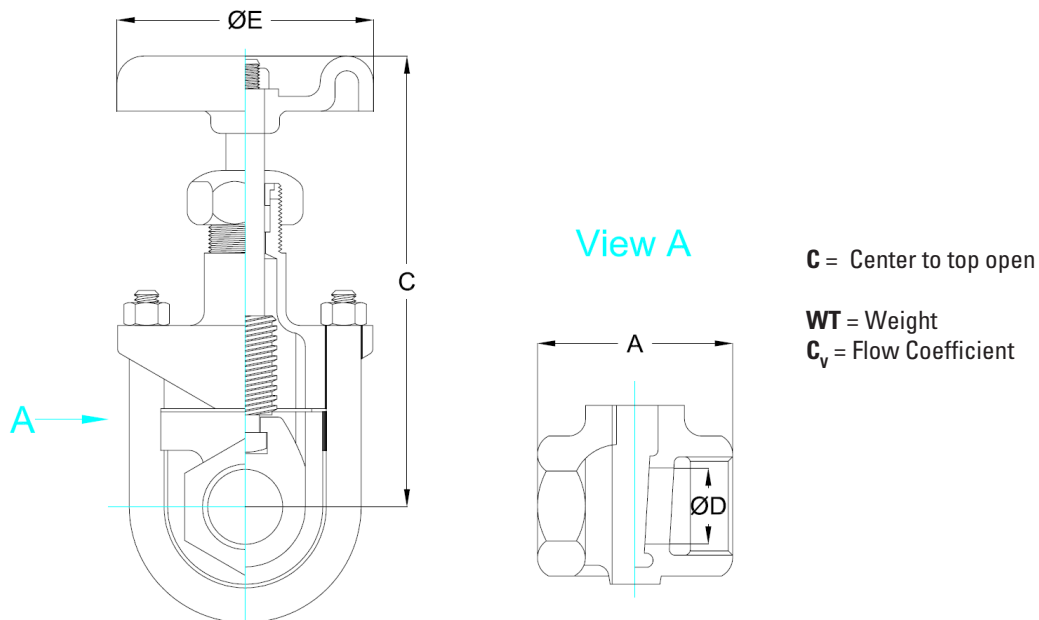

Figure 451A

# 150# Stainless Steel OS&Y Gate Valve

## Standard Materials

No.	Part Name	Material
1	Body	ASTM A351-CF8M
2	Disc	
3	Stem	ASTM A276-316
4	Nut	ASTM A194-8
5	Bolt	ASTM A193-B8
6	Body Seal	PTFE
7	Bonnet	ASTM A351-CF8M
8	Packing	PTFE
9	Hinge Pin	AISI 304
10	Eye Bolt	
11	Eye Nut	ASTM A194-8
12	Gland Flange	AISI 304
13	Stem Nut	BRONZE
14	Handle Wheel	ASTM A536 Gr.60-40-18
15	Handle Nut	AISI 304
16	Nut	
17	Nipple	
18	Socket Set Screws	
19	Gland	

**NOTES:**

CF8M Seat is Integral to Body  
 Investment Cast Body up to 8"  
 Design per API 603  
 Pressure/Temperature Rating per ANSI B16.34  
 Flange Dimensions per ANSI B16.5  
 Face to Face Dimensions per ANSI B16.10  
 Pressure Tested per API 598

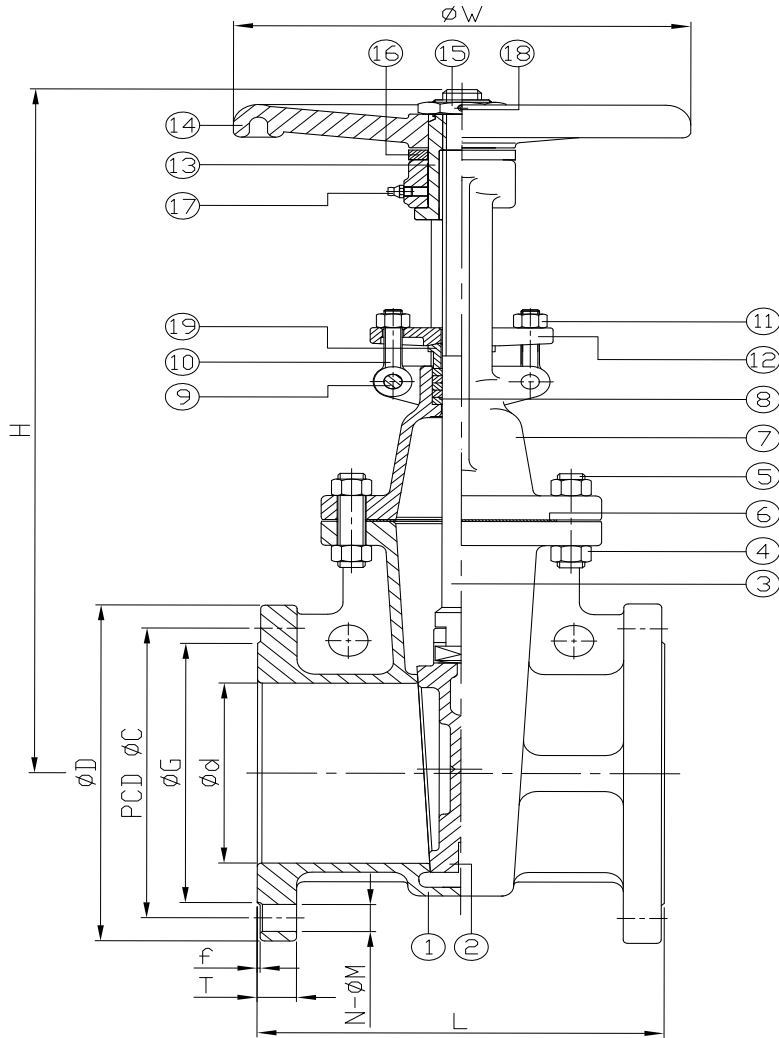

## Dimensions (inches) & Weights (lbs)

Size	2	2-1/2	3	4	6	8	10	12
d	2.01	2.52	3.15	4.02	5.98	7.99	10.00	12.01
L	7.01	7.48	7.99	9.02	10.51	11.50	12.99	14.02
H	11.89	12.44	14.72	17.36	21.18	28.50	43.98	52.56
W	7.87	7.87	9.84	9.84	11.81	13.78	15.75	17.72
Flange Dimensions	f	0.08	0.08	0.08	0.08	0.08	0.08	0.08
	D	5.91	7.09	7.48	9.06	11.02	13.58	15.94
	G	3.63	4.13	5.00	6.19	8.50	10.63	12.70
	C	4.75	5.50	6.00	7.50	9.50	11.75	14.25
	T	0.64	0.70	0.77	0.96	1.02	1.14	1.20
	N	4.00	4.00	4.00	8.00	8.00	8.00	12.00
	M	0.75	0.75	0.75	0.75	0.87	0.89	1.00
Wt. (lbs.)	29.3	35.7	48.5	83.8	127.9	191.8	317.5	469.6



**API 600 WALL GLOBE VALVES**  
BOLTED BONNET, ASME CLASS 150 TO 1500  
CAST CARBON, STAINLESS STEEL OR ALLOY STEEL

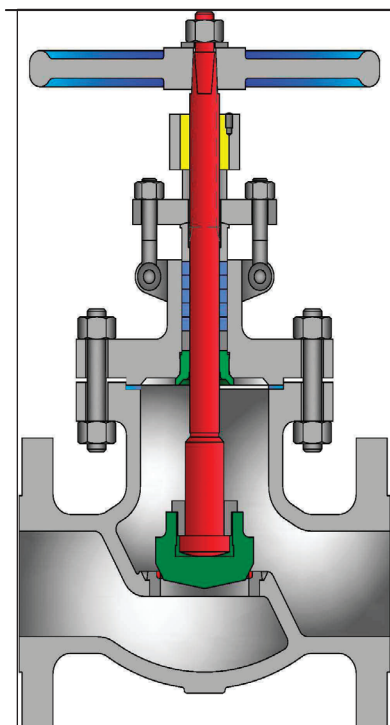

Class	Fig. No.
150	1531
300	3031
600	6031
900	9031
1500	1331

**STANDARD MATERIALS (Other materials available)**

PART	MATERIALS			
	Body	A216 Gr. WCB	A217 Gr. WC6	A217 Gr. WC9
Bonnet	A216 Gr. WCB	A217 Gr. WC6	A217 Gr. WC9	A351 Gr. CF8M
Disc	A105 or A216 WCB + 13% Cr Faced	A217 WC6 + Stellite 6 Faced	A217 WC9 + Stellite 6 Faced	SST 316
Disc Nut	SST 410			SST 316
Seat Ring	A105 or A216 WCB + Stellite 6 Faced	A182 F11 + Stellite 6 Faced	A182 F22 + Stellite 6 Faced	A351 Gr.CF8M
Stem	SST 410			SST 316
Stem Bushing	A 439 Ductile NI-Resist Gr. D2			
Stem Bushing Set Screw	Steel			Series 300 SST
Gland Flange	Carbon Steel			A351 Gr. CF8M
Eye Bolt	A193 Gr. B7			Series 300 SST
Eye Bolt Nut	A194 Gr. 2H			A194 Gr.8
Groove Pin	Steel			Series 300 SST
Gland	SST 410			SST 316
Packing	Graphite			PTFE
Packing Washer	SST 410			SST 316
Gasket	Class 150: Corrugated SST Encapsulated w/ Graphite Class 300 to 600: Spiral Wound SST with Graphite Class 900 to 1500: RTJ			Class 150: PTFE Class 300-600: Spiral Wound SST with PTFE
Back Seat	SST 410			SST 316
Hand Wheel	Malleable Iron or Steel			
Hand Wheel Nut	Malleable Iron or Steel			
Body / Bonnet Stud	A193 Gr. B7	A193 Gr. B16		A193 Gr. B8
Body / Bonnet Nut	A194 Gr. 2H	A194 Gr. 7		A194 Gr.8
Identification Plate	Series 300 SST			

**DESIGN FEATURES:**

- **Standard trim** is API trim 8 for carbon steel valves, API trim 5 for chrome alloy valves, and API trim 10 for CF8M (T316) valves for optimal performance under normal conditions. Other trim materials available on request.
- **Wall thickness** per heavy wall API 600 requirements.
- **Seat faces** lapped for smooth finish and superior sealing.
- **Swivel disc** for optimal seating and longer seat life.
- **Stems** of hand wheel operated valves are rotating / rising design.
- **Each** valve is shell, seat and backseat pressure tested per industry standard API 598.
- **Gland** is two piece gland / gland flange design for optimal alignment and uniform packing compression.
- **End Flanges** have the following raised faces per ASME B16.5:  
Classes 150-300: 1/16" (2mm)  
Classes 600-1500: 1/4" (7mm)

(1) Weld end valve body A351 Gr. CF3M

**NOTE: See page 52 for flow, safety and maintenance information.**

**Design Specifications**

Item	Applicable Specification
Wall thickness	API 600
Pressure - temperature ratings	ASME B16.34
General valve design	B16.34
End to End dimensions	ASME B16.10
Flange design	ASME B16.5
Butt Weld design	ASME B16.25
Materials	ASTM

- **Weld ends** are available per ASME B16.25 or per customer's specification.
- **Impactor** hand wheel design standard on the following sizes to assist seating.  
8" to 12" class 150  
6" to 12" class 300  
4" to 10" 600  
For larger sizes or pressure classes, gears are standard.
- **Each** valve has a unique certification number that is traceable to the valve certification sheet which includes MTR data, pressure test, inspection result and certificate of conformance.
- **Other** available options as follows:  
-Alternate valve materials such as chrome and stainless steel alloys  
-Alternate trim materials  
-Bypass, drain and other auxiliary connections  
-Gear, motor, and cylinder actuators available  
-NACE service  
-Special cleaning for applications such as oxygen or chlorine  
-Other options available as specified



**GLOBE VALVE DIMENSIONS (CLASS 150—1500).**

SIZE	ASME 150					ASME 300					ASME 600				
	A	B	C	D	E	A	B	C	D	E	A	B	C	D	E
	WE/FE					WE/FE					WE/FE				
2	8.00	11.9	12.9	2.00	8	10.50	11.9	13.1	2.00	8	11.50	13.6	14.7	2.00	10
50	203	302	327	51	200	267	302	332	51	200	292	346	374	51	250
2 ½	8.50	14.9	16.4	2.50	8	11.50	12.9	14.5	2.50	10	13.00	16.4	17.6	2.50	12
65	216	378	416	64	200	292	328	369	64	250	330	416	448	64	300
3	9.50	14.1	15.4	3.00	10	12.50	14.1	15.4	3.00	12	14.00	17.2	18.7	3.00	14
80	241	357	390	76	250	318	357	390	76	300	356	438	475	76	350
4	11.50	16.5	18.0	4.00	12	14.00	16.7	18.0	4.00	14	17.00	20.2	21.7	4.00	18
100	292	419	457	102	300	356	423	458	102	350	432	514	552	102	450
6	16.00	17.6	19.7	6.00	14	17.50	21.0	23.2	6.00	18	22.00	25.7	27.9	6.00	20
150	406	446	499	152	350	444	534	589	152	450	559	653	709	152	500
8	19.50	20.1	22.6	8.00	18	22.00	23.9	26.3	8.00	18	26.00	29.1	31.6	7.87	22
200	495	511	574	203	450	559	606	669	203	450	660	739	803	200	560
10	24.50	29.5	33.6	10.00	18	24.50	29.7	35.1	10.00	22	31.00	32.7	38.9	9.75	28
250	622	750	853	254	450	622	753	892	254	560	787	830	988	248	710
12	27.50	31.9	36.7	12.00	20	28.00	34.2	41.2	12.00	26	33.00	47.8 (1)		11.75	28
300	698	810	932	305	500	711	868	1047	305	650	838	1215		298	710
14	31.00	42.5 (1)		13.25	24	33.00	45.9 (1)		13.25	24	35.00	51.2 (1)		12.87	32
350	787	1080		337	610	838	1165		337	610	889	1401		327	810
16	36.00	45.1 (1)		15.25	24	34.00	51.4 (1)		15.25	24	39.00	56.4 (1)		14.75	40
400	914	1146		387	610	864	1305		387	610	991	1630		375	1000
18	38.50	50.1 (1)		17.25	28	38.50	57.2 (1)		17.00	24	43.00	61.7 (1)		16.50	40
450	978	1450		438	710	978	1453		432	610	1092	1567		419	1000
20	38.50	55.9 (1)		19.25	28	40.00	62.2 (1)		19.00	40	47.00	67.3 (1)		18.25	40
500	978	1420		489	710	1016	1579		483	1000	1194	1710		464	1000
24	51.00	67.7 (1)		23.25	32	53.00	72.9 (1)		23.00	40	55.00	78.9 (1)		22.00	60
600	1295	1720		591	810	1346	1852		584	1000	1397	2004		559	1500

(1) Gear operators standard for 14" and up classes 150 and 300, 12" and up for class 600, 6" and up for classes 900 and 1500. Height is to top of actuator.

**ADDITIONAL SIZES, MATERIALS AND CLASSES AVAILABLE UPON REQUEST.**

SIZE	ASME 900					ASME 1500				
	A	B	C	D	E	A	B	C	D	E
	WE/FE					WE/FE				
2	14.50	19.0	20.6	1.87	14	14.50	19.0	20.6	1.87	14
50	368	483	523	48	350	368	483	523	48	350
2 ½	16.50	19.0	20.6	2.25	14	16.50	19.0	20.6	2.25	16
65	419	483	523	57	350	419	483	523	57	400
3	15.00	23.8	25.5	2.87	18	18.50	27.9	28.9	2.75	18
80	381	605	648	73	450	470	702	735	70	450
4	18.00	26.0	28.2	3.87	18	21.50	28.0	30.2	3.62	18
100	457	661	716	98	450	546	712	767	92	450
6	24.00	33.6 (1)		5.75	24	27.75	39.2 (1)		5.37	28
150	610	853		146	610	705	996		136	710
8	29.00	43.5 (1)		7.50	28	32.75	47.1 (1)		7.00	32
200	737	1105		191	710	832	1196		178	810
10	33.00	52.4 (1)		9.37	32	39.00	56.2 (1)		8.75	32
250	838	1331		238	810	991	1427		224	810

**B = Center to top closed**  
**C = Center to top open**

**WE = Butt weld ends**  
**FE = Flanged ends**

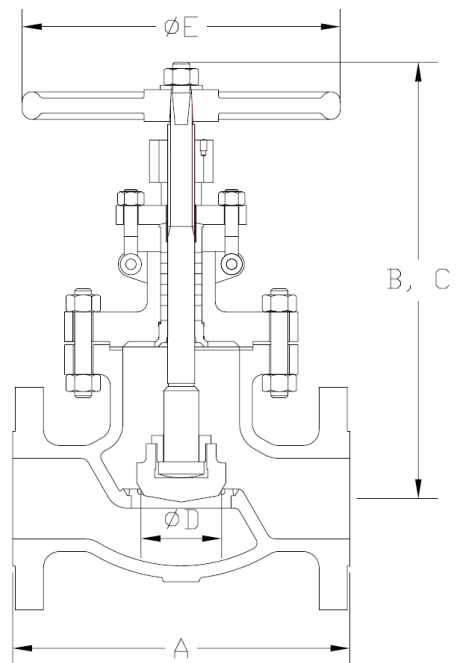

SIZE	ASME 150							ASME 300							ASME 600								
	in mm	F	in mm	WT FE	lb kg	WT WE	lb kg	C <sub>v</sub>	F	in mm	WT FE	lb kg	WT WE	lb kg	C <sub>v</sub>	F	in mm	WT FE	lb kg	WT WE	lb kg	C <sub>v</sub>	
2	17.5		38		34		50		18.5		49		40		50		21.0		71		57		50
50	440		17		15				470		22		18				535		32		26		
2 ½	16.5		45		40		75		17.0		71		56		75		21.5		115		90		75
65	425		21		18				435		32		25				545		52		41		
3	20.5		77		66		110		21.5		104		84		110		24.0		148		121		110
80	520		35		30				545		47		38				610		67		55		
4	24.0		121		104		200		26.5		165		142		200		29.5		260		227		200
100	615		55		47				670		75		65				745		118		103		
6	28.5		205		175		480		31.5		280		232		480		38.0		585		584		480
150	720		93		79				795		127		105				960		265		265		
8	31.0		353		300		880		41.0		565		408		880		44.0		1010		904		850
200	785		160		136				1035		256		185				1115		458		410		
10	35.0		567		481		1370		43.0		830		672		1370		47.0		1450		1279		1300
250	895		257		218				1085		376		305				1190		658		580		
12	45.0		800		679		2050		50.5		1120		772		2050		56.5		2359		1920		2000
300	1145		363		308				1280		508		350				1435		1070		870		
14	47.0		1279		1080		2500		52.5		1786		1455		2500		60.0		4409		3629		2400
350	1200		580		490				1330		810		660				1530		2000		1646		
16	52.0		1742		1477		3300		56.0		2491		2028		3300		63.0		4982		4079		3100
400	1320		790		670				1420		1130		920				1605		2260		1850		
18	55.0		1874		1587		4400		64.5		3527		2866		4300		73.0		6812		5578		4000
450	1400		850		720				1640		1600		1300				1855		3090		2530		
20	60.0		1984		1676		5500		70.5		5710		3417		5300		79.5		8664		7099		4900
500	1525		900		760				1790		2590		1550				2015		3930		3220		
24	68.0		3307		2756		8000		82.0		10141		6107		7800		92.0		13161		10869		7200
600	1725		1500		1250				2080		4600		2770				2340		5970		4930		

SIZE	ASME 900							ASME 1500							
	in mm	F	in mm	WT FE	lb kg	WT WE	lb kg	C <sub>v</sub>	F	in mm	WT FE	lb kg	WT WE	lb kg	C <sub>v</sub>
2	23.5		185		150		40		23.5		201		154		40
50	595		84		68				595		91		70		
2 ½	24.5		254		198		60		27.5		331		232		60
65	625		115		90				695		150		105		
3	26.5		290		238		100		30.0		452		364		90
80	675		132		108				765		205		165		
4	31.5		487		397		190		34.0		597		465		160
100	805		221		180				865		271		211		
6	42.0		891		728		440		46.0		1111		882		380
150	1065		404		330				1175		504		400		
8	45.0		1592		1323		770		57.5		2668		2161		670
200	1145		722		600				1460		1210		980		
10	55.0		2646		2094		1200		62.0		4850		3858		1050
250	1390		1200		950				1580		2200		1750		

**FE** = Flanged ends  
**WE** = Weld ends

**F** = Dismantling dimension

**WT** = Weight  
**C<sub>v</sub>** = Flow coefficient

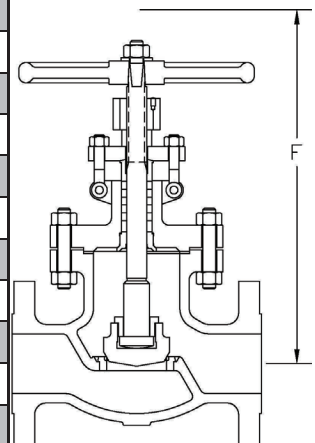

# 'Apollo' Valves

# SUBMITTAL SHEET

## 107T Series

Class 150, Rising Stem, NPT Gate Valve



<b>Job Name:</b>	
<b>Job Location:</b>	
<b>Engineer:</b>	
<b>Contractor:</b>	
<b>Tag:</b>	
<b>PO Number:</b>	
<b>Representative:</b>	
<b>Wholesale Distributor:</b>	



### DESCRIPTION

The Apollo Model 107T (30 Series) Gate Valve provides a cost effective "Made in the USA" alternative to globally sourced multi-turn valves. These valves are cast, machined, assembled, and tested in South Carolina. The Apollo Gate Valve can reliably be installed in most plumbing and heating systems (or building service piping).

### FEATURES

- Guided Solid Bronze Discs
- Adjustable Graphite Stem Packing
- Rising Stem
- Dezincification Resistant
- All Bronze Construction
- 100% Factory tested
- NPT Connection
- Union Bonnet
- Malleable Iron Rugged Hand Wheel
- **100% Cast, Machined and Assembled in the US**
- ARRA Compliant

### STANDARDS

- MSS SP-80, "Bronze Gate, Globe, Angle & Check Valves"
- ASME B1.20.1, "Pipe Threads, General Purpose (Inch)"
- Canadian Registration Number OC14667.5

### PERFORMANCE RATING

- Saturated Steam: 150 psi (10.3 Bar) to 366°F (185°C)
- Cold Working Pressure: 300psi (20.7 Bar)
- Temperature Range\*: -20°F to 406°F

\* Valves should be in open position to allow complete drainage during freezing conditions.

### STANDARD MATERIALS LIST

Part Name	Material
Body	ASTM B62 Bronze
Bonnet	ASTM B62 Bronze
Stem	ASTM B371 Bronze
Union Nut	ASTM B371/B62 Bronze
Disc	ASTM B62 Bronze
Packing	Grafoil®
Packing Nut	ASTM B16 Brass
Hand Wheel	Malleable Iron
Nameplate	Aluminum

### ORDER INFORMATION

Model Number	Part Number	Size (in.)
107T14	30-201-01	1/4"
107T38	30-202-01	3/8"
107T12	30-203-01	1/2"
107T34	30-204-01	3/4"
107T1	30-205-01	1"
107T114	30-206-01	1-1/4"
107T112	30-207-01	1-1/2"
107T2	30-208-01	2"
107T212	30-209-01	2-1/2"
107T3	30-200-01	3"

### DIMENSIONS

Height open (in.)	Length (in.)	Weight (lbs)	Cv (gpm)
4.57	1.76	.90	3.0
4.51	1.76	.87	6.0
4.85	2.03	1.07	12.5
5.71	2.07	1.43	24.0
6.71	2.45	2.44	72.3
8.10	2.63	3.70	80.0
9.13	2.88	4.95	119.0
11.28	3.06	7.53	338.0
14.58	4.13	15.33	395.0
16.90	4.48	19.56	435.0

Apollo Valves, Manufactured by **Conbraco Industries, Inc.**  
 701 Matthews Mint-Hill Road, Matthews, NC 28105 USA  
[www.apollovalves.com](http://www.apollovalves.com) | (704) 841-6000

This specification is provided for reference only. Conbraco Industries Inc. reserves the right to change any portion of this specification without notice and without incurring obligation to make such changes to Conbraco products previously or subsequently sold. Please visit our website @ [www.apollovalves.com](http://www.apollovalves.com) for the most current information.



## **STAINLESS STEEL HIGH PERFORMANCE TRANSMITTER ISOLATION VALVE**

The figure 2020TIVT is an all cast stainless steel body and yoke with investment cast packing follower.

### **Features:**

- Reinforced Teflon Seats for Positive Shut Off at Minimal Line Pressure
- Bidirectional Shutoff
- Cast Stainless Steel Body, Yoke and Packing Gland
- Reversible Ratchet Operator, Standard
- Rising Stem
- Meets MSS SP-81 Specifications for 150 PSI CWP
- Available in size 3"

### **Standards:**

- Design: MSS SP-81
- Flange Drilling: ANSI B16.5
- Material: ASME B16.34

### **Part Number**

<b>Size</b>	<b>Part Number</b>
3"	FNW2020TIVT

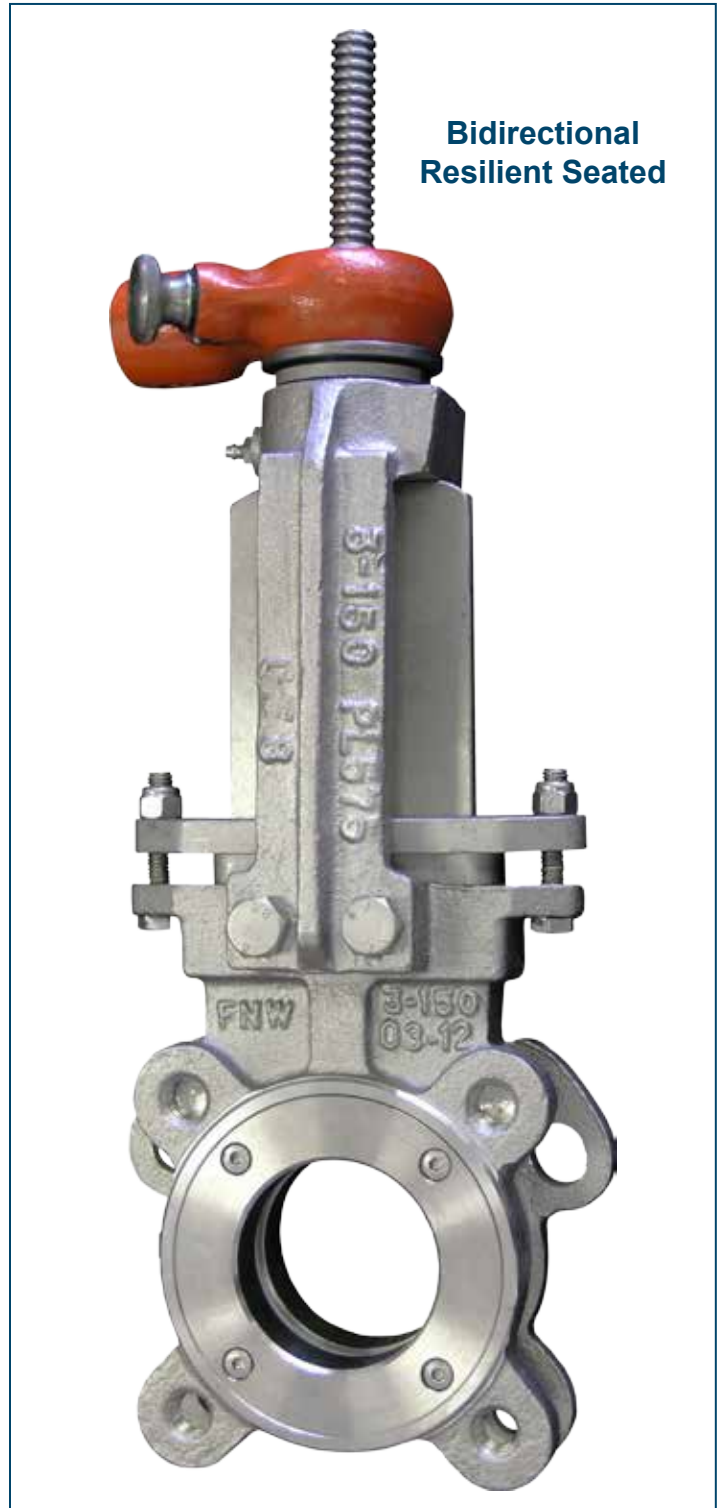

## Standard Materials

25	LOCK NUT	ST.STEEL 304
24	LOCKING PIN	ASTM A 276 Gr. 304
23	BOLT & NUT, NYLOCK (Arrow indicator)	ST.STEEL 304
22	ARROW INDICATOR	ASTM A 240 Gr.304
21	FASTNERS (Stem & Stopper)	ASTM A 193 Gr.B8/ASTM A 194 Gr.8
20	STOPPER	ASTM A 276 Gr.304
19	RACHET LEVER	CARBON STEEL ASTM A 36
18	GREASE NIPPLE	BRASS
17	COLLAR	ASTM A 240 Gr.SS 304
16	THRUST NEEDLE BEARING	STAINLESS STEEL
15	YOKE SLEEVE	ASTM B 148 Gr. C95200
14	BOLT & NUT , NYLOCK (Clevis)	ST.STEEL 304
13	STEM	ASTM A 276 Gr.304
12	CLEVIS	ASTM A 351 Gr.CF8
11	BOLTS (Yoke)	ST.STEEL 304
10	YOKE	ASTM A 351 Gr.CF8
9	BOLT & NUT , NYLOCK (Gland)	ST.STEEL 304
8	GLAND	ASTM A 351 Gr.CF8M
7	PACKING	PTFE WITH ONE LAYER OF EPDM QUAD SEAL
6	FASTENERS (Retainer Ring & Body)	ASTM A 193 Gr.B8M
5	RETAINER RING	ASTM A 351 Gr.CF8M
4	O'RING	EPDM
3	SEAT RING	RTFE
2	GATE	ASTM A 240 Gr.316
1	BODY	ASTM A 351 Gr.CF8M
ITEM No.	DESCRIPTION	MATERIAL

## Options

FNW Valve Company offers many options and modifications for valves. These include, but are not limited to:

- Actuation including ratchets, chain wheels, AWWA nuts, gear-operators, pneumatic & hydraulic cylinders, and electric actuators
- Packing options for pH and temperature requirements
- Back seat stops for low  $\Delta P$  or reverse operation applications, or to prevent knife blade deflection
- V-ports for reduced plugging in metering applications
- Stem extensions in carbon and stainless steel
- Conversion to non-rising stem (NRS)
- Deflection cones in Ni-Hard and HDPE for added seat and gate protection in abrasive services
- Flush ports to clear suspended matter from the valve chest or seat pocket area
- Quick opening levers
- Gate scraper



# STAINLESS STEEL HIGH PERFORMANCE TRANSMITTER ISOLATION VALVE

DOC: FNW2000BTIV05 Ver. 8/2017

© 2017 - FNW. All rights reserved.

The FNW logo is a trademark of Ferguson Enterprises, Inc., PL Sourcing, PO Box 2778, Newport News, VA 23609

The contents of this publication are presented for information purposes only, and while effort has been made to ensure their accuracy, they are not to be construed as warranties or guarantees, expressed or implied, regarding the products or services described herein or their use or applicability. All sales are governed by our terms and conditions, which are available on request. We reserve the right to modify or improve the designs or specifications of our products at any time without notice. Always verify that you have the most recent product specifications or other documentation prior to the installation of these products.





Globe valves are closing-down valves in which the closure member is moved squarely on and off the seat. In this way the opening of the port is directly proportional to the travel of the disc. This proportional relationship is ideally suited for duties requiring regulation of flow rate. To have a further precision in regulation the disc element can be available in the parabolic, needle, vee-port types. Furthermore the short travel of the disc between the open and closed position makes these valves ideally suited for on-off duties when they must be opened and closed frequently. Globe valves are unidirectional valves and are installed so that fluid pressure is under the disc. They are supplied in various models to cover the different services. Among these valves the Eco-L-Valve® combines the characteristics of total safety against leakages to the easy substitution of the most delicate components such as the bellows. The main characteristics of each type are described on pages 24 to 31.

**Figure # is identified in each table as:**

STANDARD PORT	830	-
FULL PORT	630	1/4
		mm

CLASS	CONNECTION	PORT	STANDARD	SCREW & YOKE	ENDS	SERVICE	PAGE	OMB FIG.
800	Bolted bonnet	Regular	ISO15761	Outside	Threaded and Socket Weld Ends	-	25	830
800	Bolted bonnet	Full	ISO15761	Outside	Threaded and Socket Weld Ends	-	25	630
800	Welded Bonnet	Regular	ISO15761	Outside	Threaded and Socket Weld Ends	-	25	L830
800	Welded Bonnet	Full	ISO15761	Outside	Threaded and Socket Weld Ends	-	25	L630
800	Welded Bonnet	Regular	ISO15761	inside	Threaded and Socket Weld Ends	-	25	L820
800	Welded Bonnet	Full	ISO15761	inside	Threaded and Socket Weld Ends	-	25	L620
1500	Bolted bonnet	Regular	ISO15761	Outside	Threaded and Socket Weld Ends	-	25	R930
1500	Bolted bonnet	Full	ISO15761	Outside	Threaded and Socket Weld Ends	-	25	930
1500	Welded Bonnet	Regular	ISO15761	Outside	Threaded and Socket Weld Ends	-	26	LR930
1500	Welded Bonnet	Full	ISO15761	Outside	Threaded and Socket Weld Ends	-	26	L930
1500	Ring Joint BB	Full	ISO15761	Outside	Threaded and Socket Weld Ends	-	26	RJ930
2500	Ring Joint BB	Full	ANSI B16.34	Outside	Threaded and Socket Weld Ends	-	26	RJ2530
2500	Welded Bonnet	Full	ANSI B16.34	Outside	Threaded and Socket Weld Ends	-	26	L2530
4500	Welded Bonnet	Full	ANSI B16.34	Outside	Threaded and Socket Weld Ends	-	27	RJ4530
4500	Welded Bonnet	Full	ANSI B16.34	Outside	Threaded and Socket Weld Ends	-	27	L4530
4500	Welded Bonnet	Full	ANSI B16.34	Outside	Threaded and Socket Weld Ends	-	27	RJ-4530-BW
4500	Welded Bonnet	Full	ANSI B16.34	Outside	Threaded and Socket Weld Ends	-	27	L4530-BW
800	Welded Bonnet	Full	ISO15761	Outside	Threaded and Socket Weld Ends	-	28	Y630
1500	Welded Bonnet	Full	ISO15761	Outside	Threaded and Socket Weld Ends	-	28	Y930
2500	Welded Bonnet	Full	ANSI B16.34	Outside	Threaded and Socket Weld Ends	-	28	Y2530
4500	Welded Bonnet	Full	ANSI B16.34	Outside	Threaded and Socket Weld Ends	-	28	Y4530
150	Welded Bonnet	Full	ISO15761	Outside	Flanged	-	29	1-Y630
300	Welded Bonnet	Full	ISO15761	Outside	Flanged	-	29	3-Y630
600	Welded Bonnet	Full	ISO15761	Outside	Flanged	-	29	6-Y630
150	Bolted bonnet	Regular	ISO15761	Outside	Flanged	-	29	F1-830
300	Bolted bonnet	Regular	ISO15761	Outside	Flanged	-	29	F3-830
600	Bolted bonnet	Regular	ISO15761	Outside	Flanged	-	29	F6-830
150	Bolted bonnet	Full	ISO15761	Outside	Flanged	-	29	F1-630
300	Bolted bonnet	Full	ISO15761	Outside	Flanged	-	29	F3-RJ-630
600	Bolted bonnet	Full	ISO15761	Outside	Flanged	-	29	F6-RJ-630
1500	Ring Joint BB	Full	ISO15761	Outside	Flanged	-	29	F9-RJ930
2500	Ring Joint BB	Full	ISO15761	Outside	Flanged	-	29	F25-RJ2530
800	Bolted bonnet	Regular	ISO15761	Outside	Threaded and Socket Weld Ends	Sour Service	30	SS830
800	Welded Bonnet	Regular	ISO15761	Outside	Threaded and Socket Weld Ends	Alkilation	30	AS-L830
800	Welded Bonnet	Regular	ISO15761	Outside	Threaded and Socket Weld Ends	Vacuum	30	VS-L830
800	Bolted bonnet	Regular	ISO15761	Outside	Threaded and Socket Weld Ends	Chlorine	30	CS-830

**Note** Bellows Seal Valves please see C-BS Bellows Seal Valve Catalog  
 Cryogenic Service Valves please see C-CR2 Cryogenic Service Valve Catalog  
 Pressure Seal Valves please see C-PS Pressure Seal Valve Catalog  
 Thru Conduit Valves please see C-TC Pressure Thru Conduit Valves Catalog  
 Y Pattern Valves please see C-HTHP High Pressure - High Temperature Valves

**Eco-L-Valves**  
 OMB introduced an innovative solution to the Fugitive Emission issue: Eco-L-Valves Special patented Short Pattern Bellows Seal valves, with dimension equal to standard non-bellows valves and able to meet the severe service conditions of standard bellows seal with a lower dimensional height and reduced cost impact.

JIS Valve Standards please see JIS Section on this catalog  
 DIN Valve Standards please see DIN Section on this catalog

ECO-L-VALVES please see C-BS Bellows Seal Valve Catalog



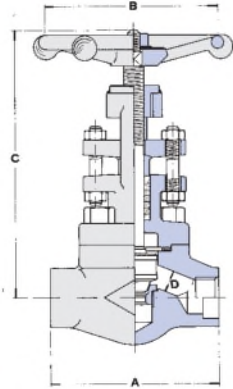

RATINGS: Carbon Steel - 1975 p.s.i. @ 100°F

## CLASS 800

**BOLTED BONNET - STANDART PORT TO API602/ISO 15761 - FULL PORT TO BS 5352**  
Outside Screw & Yoke - Threaded and Socket Weld Ends

STANDARD PORT	830	-	1/2	3/4	1	1.1/4	1.1/2	2	-								
FULL PORT	630	1/4	3/8	1/2	3/4	1	1.1/4	1.1/2	2								
		mm	in.	mm	in.	mm	in.	mm	in.	mm	in.	mm	in.				
End to End	<b>A</b>	80	3.14	80	3.14	90	3.54	110	4.33	127	5.00	155	6.10	170	6.69	210	8.26
Handwheel	<b>B</b>	80	3.14	80	3.14	80	3.14	110	4.33	130	5.11	130	5.11	180	7.08	180	7.08
Center to Top Open	<b>C</b>	148	5.82	148	5.82	165	6.49	180	7.08	213	8.38	248	9.76	257	10.1	370	14.5
Dia. of Port	<b>D</b>	7	0.28	9	0.35	13	0.51	17.5	0.69	23	0.89	29.5	1.16	35	1.37	45.5	1.79
Approx. Weight	<b>Kg / Lb</b>	1.7	3.7	1.7	3.7	2.3	5.0	3.6	7.9	5.5	12.1	7.5	16.5	11.6	25.5	22.0	48.5

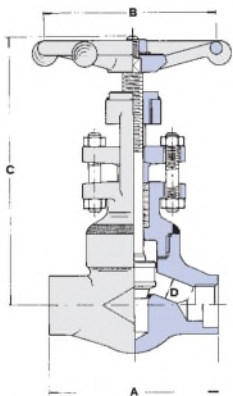

RATINGS: Carbon Steel - 1975 p.s.i. @ 100°F

## CLASS 800

**WELDED BONNET - STANDART PORT TO API602/ISO 15761 - FULL PORT TO BS 5352**  
Outside Screw & Yoke - Threaded and Socket Weld Ends

STANDARD PORT	L830	-	1/2	3/4	1	1.1/4	1.1/2	2	-								
FULL PORT	L630	1/4	3/8	1/2	3/4	1	1.1/4	1.1/2	2								
		mm	in.	mm	in.	mm	in.	mm	in.	mm	in.	mm	in.				
End to End	<b>A</b>	80	3.14	80	3.14	90	3.54	110	4.33	127	5.00	155	6.10	170	6.69	210	8.26
Handwheel	<b>B</b>	80	3.14	80	3.14	80	3.14	110	4.33	130	5.11	130	5.11	180	7.08	180	7.08
Center to Top Open	<b>C</b>	148	5.82	148	5.82	165	6.49	180	7.08	213	8.38	248	9.76	257	10.1	370	14.5
Dia. of Port	<b>D</b>	7	0.28	9	0.35	13	0.51	17.5	0.69	23	0.89	29.5	1.16	35	1.37	45.5	1.79
Approx. Weight	<b>Kg / Lb</b>	1.7	3.7	1.7	3.7	2.3	5.0	3.6	7.9	5.5	12.1	7.3	16	10.5	23.1	17.5	38.5

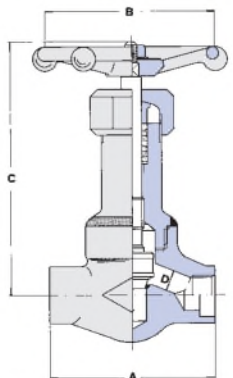

RATINGS: Carbon Steel - 1975 p.s.i. @ 100°F

## CLASS 800

**WELDED BONNET - STANDART PORT TO API602/ISO 15761 - FULL PORT TO BS 5352**  
Inside Screw - Threaded and Socket Weld Ends

STANDARD PORT	L820	-	1/2	3/4	1	1.1/4	1.1/2	2	-								
FULL PORT	L620	1/4	3/8	1/2	3/4	1	1.1/4	1.1/2	2								
		mm	in.	mm	in.	mm	in.	mm	in.	mm	in.	mm	in.				
End to End	<b>A</b>	80	3.14	80	3.14	90	3.54	110	4.33	127	5.00	155	6.10	170	6.69	210	8.26
Handwheel	<b>B</b>	80	3.14	80	3.14	80	3.14	110	4.33	130	5.11	130	5.11	130	5.11	180	7.08
Center to Top Open	<b>C</b>	148	5.82	148	5.82	175	6.88	212	8.34	235	9.25	287	11.3	327	12.9	380	15.0
Dia. of Port	<b>D</b>	7	0.28	9	0.35	13	0.51	17.5	0.69	23	0.89	29.5	1.16	35	1.37	45.5	1.79
Approx. Weight	<b>Kg / Lb</b>	1.5	3.3	1.5	3.3	2.0	4.4	3.7	8.1	5.5	12.1	7.3	16	10.5	23.1	17.5	38.5

Bolted Bonnet Type on request

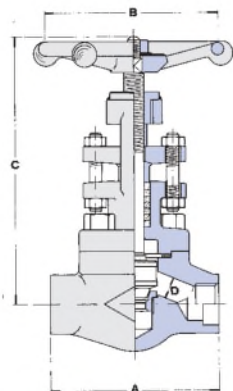

RATINGS: Carbon Steel - 3705 p.s.i. @ 100°F

## CLASS 1500

**BOLTED BONNET - STANDART PORT TO API602/ISO 15761 - FULL PORT TO BS 5352**  
Outside Screw & Yoke - Threaded and Socket Weld Ends

STANDARD PORT	R930	-	1/2	3/4	1	1.1/4	1.1/2	2	-								
FULL PORT	930	1/4	3/8	1/2	3/4	1	1.1/4	1.1/2	2								
		mm	in.	mm	in.	mm	in.	mm	in.	mm	in.	mm	in.				
End to End	<b>A</b>	90	3.54	90	3.54	110	4.33	127	5.00	155	6.10	170	6.69	210	8.26	210	8.26
Handwheel	<b>B</b>	80	3.14	80	3.14	110	4.33	130	5.11	130	5.11	180	7.08	180	7.08	180	7.08
Center to Top Open	<b>C</b>	160	6.29	160	6.29	175	6.88	210	8.26	244	9.60	250	9.84	370	14.5	375	14.7
Dia. of Port	<b>D</b>	7	0.28	9	0.35	13	0.51	17	0.67	21	0.83	28	1.10	33	1.30	37.5	1.48
Approx. Weight	<b>Kg / Lb</b>	2.2	4.8	2.2	4.8	3.9	8.5	6	13.2	8	17.6	12	26.4	23.5	51.7	23	50.6

# ASME B16.34 GLOBE VALVES

BOLTED BONNET, ASME CLASSES 150 - 300  
 6" - 12" (150 - 300mm), FLANGED OR BUTTWELD ENDS  
 CAST STAINLESS STEEL

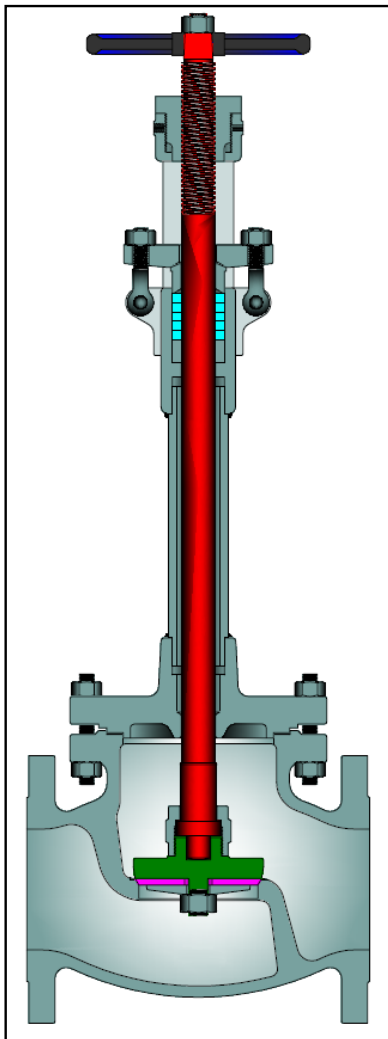

Class	Fig. No.
150	2475
300	2447

### STANDARD MATERIALS (Other materials available)

PART	MATERIALS
Body	A351 Gr. CF8M (1)
Bonnet	A351 Gr. CF8M
Yoke	A351 Gr. CF8M
Disc or Disc Holder (2)	A276 316
Disc Insert (2)	PCTFE
Disc Washer (2)	SST 316
Disc Insert Nut (2)	A194 Gr. 8
Disc Locknut	A276 316
Stem	A276 316
Stem Bushing	A439 D-2
Gland Flange	A351 Gr. CF8
Eye Bolt	A193 Gr. B8
Eye Bolt Nut	A194 Gr.8
Gland	A276 316
Packing	PTFE
Packing Washer / Packing Spacer	A276 316
Gasket	Graphite
Extension Column	SST 304
Hand Wheel	Malleable Iron or Steel
Hand Wheel Nut	Steel
Body / Bonnet Stud	A193 Gr. B8
Body / Bonnet Nut	A194 Gr.8
Identification Plate	Series 300 SST

1. CF3M for weld end bodies.
2. Soft seat design.

### Design Specifications

Item	Applicable Specification
Wall thickness	ASME B16.34
Pressure - temperature ratings	ASME B16.34
General valve design	B16.34
End to End dimensions	ASME B16.10
Flange design	ASME B16.5
Butt Weld design	ASME B16.25
Materials	ASTM

### DESIGN FEATURES:

- Seat face: Ground and lapped to a smooth finish.
- Body and bonnet joint accurately machined.
- Swivel disc for optimal seating and longer seat life.
- Stems of hand wheel operated design are rotating / rising design.
- Each valve is shell, seat and backseat pressure tested.
- Integral seats are standard. Renewable seat rings available on special order.
- Gland has two-piece construction for easy alignment.
- Weld ends are available per ASME B16.25 or per customer's specification.
- Flanges:
  - Classes 150-300: 1/16" raised face.
  - Finish 125-250 AARH for all valves.
- Valves are specially cleaned and processed for oxygen or cryogenic service and are then sealed to prevent contamination.
- Each valve has a unique certification number that is traceable to the valve certification sheet which includes MTR data, pressure test, inspection result and certificate of conformance.
- Heavier walled API 600 design available.
- Other available options as follows:
  - » Alternate valve materials
  - » Alternate trim materials
  - » Non-extended design
  - » Other options available as specified

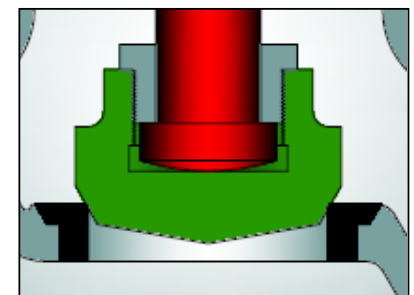

Metal Disc

# GLOBE VALVE DIMENSIONS (CLASSES 150 - 300)

SIZE	ASME 150										ASME 300											
	in	A	C	D	E	X (1)	WT	lb	WT	lb	$C_v$	A	C	D	E	X (1)	WT	lb	WT	lb	$C_v$	
							FE	kg	WE	kg							FE	kg	WE	kg		
6	16.0	18.5	6.0	15.8	20.0		241		197		480	17.5	18.5	6.00	17.7	20.0		352		283		480
150	406	470	152	400	508		109		89			445	470	152	450	508		160		128		
8	19.5	18.5	8.0	17.7	24.0		266		225		880	See Powell Engineering for More Information										
200	495	470	203	450	610		121		102													
10	24.5	19.5	10.0	21.7	28.0		433		362		1370											
250	622	495	254	550	711		196		164													
12	27.5	25.6	12.0	23.6	28.0		575		560		2050											
300	699	650	305	600	711		261		254													

(1) Other extensions available. Consult Powell Engineering.

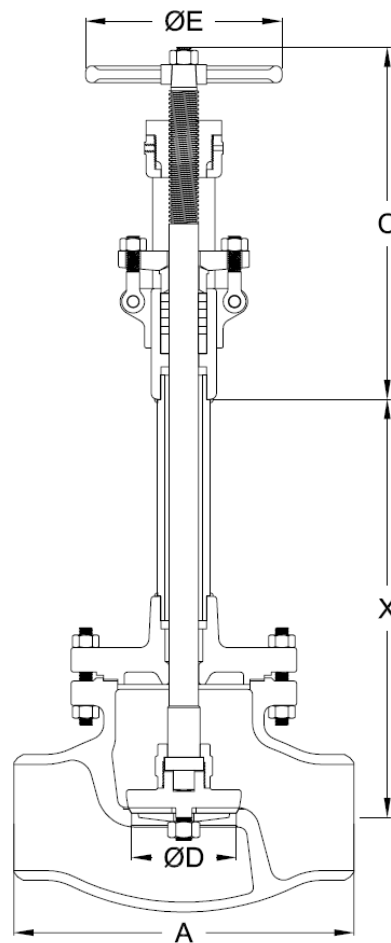

**C** = Bottom of yoke flange to top open  
**X** = Center to bottom of yoke flange (Std)

**FE** = Flanged ends  
**WE** = Buttweld ends  
**WT** = Weight  
 **$C_v$**  = Flow coefficient

Weld End Design

**Integral Bonnet Needle Valves** For regulating and shut-off

**Stem**

Hard chrome plated stem threads assures extended service life

**Choice of Fluid Control**

- Metal to metal Vee & Regulating stems for elevated temperatures
- Repetitive soft seat for gas leak-tight

**Variety of end connections**

- Reliable DK-Lok Tube Fitting Ends
- NPT & ISO Male & Female

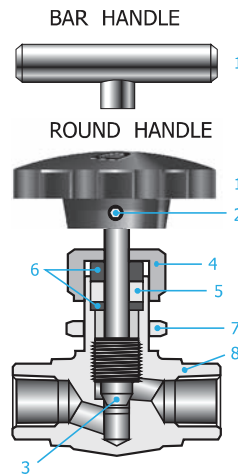

**Positive Driven Handle**

Choice of Round handle and Bar handle

**Packing Nut**

Allows external adjustments of packing

**Panel Nut**

Allows panel installation

**Integral Bonnet Design**

To eliminate inadvertent stem back-out

**Packing**

- Low operating torque.
- Standard PTFE
- Optional Chevron PEEK for high temperature

**Materials of Construction**

Components	VALVE BODY MATERIALS Material Grade/ASTM Specification			
	SS316	BRASS	ALLOY 400	
1	Round handle	Nylon with brass insert		
	Bar handle	SS316/A276		
2	Set Screw	SS304/A276		
3	Standard Vee Stem	SS316/A276 Hard Chrome-plated on stem tip and threads	Alloy R-405	
	Optional Regulating stem	SS316/A276 Hard Chrome-plated on threads		
	Optional Soft Seat Stem	PCTFE		
4	Packing Nut	SS316/A276	Brass/B16	Alloy R-405/B164
5	Packing	Standard PTFE, Optional PEEK		
6	Packing Gland	SS316/A276	Brass/B16	Alloy R-405/B164
7	Panel Nut	SS316/A276	Brass/B16	SS316/A276
8	Body	SS316/A182	Brass/B283	Alloy 400/B564

Wetted parts and lubricant are listed in blue.

**Lubrication** : Molybdenum disulfide with hydrocarbon coating

**Design**

- Designed for a wide range of general purpose in gas and liquid applications
- Forged Body with Inline and Angle pattern
- Integral Bonnet design to eliminate inadvertent stem back-out
- Standard metal seal for pressure tightness at elevated temperatures
- Standard PTFE packing, and optional PEEK packing for higher temperature service
- Packing nut allows external packing adjustment to ensure leak-free packing on stem
- Broad choices of end connections include reliable DK-Lok, NPT & ISO Male & Female pipe threads

**Operation**

- Pressure rating up to 5,000psig (345bar) @100°F (38°C)
- Temperature rating up to 450°F (232°C) with standard PTFE packing; up to 600°F (315°C) with optional PEEK packing
- Panel mounting without packing disruption
- Standard SS316 and Brass material valve construction
- DK-Lok Gap gauge allows easy inspection for sufficient tube pull-up before a system is pressurized
- Valves for Sour Gas Service meeting the requirements of NACE MR0175 are available

**Factory Test**

Every valve is tested with the nitrogen @1,000psig (68bar) for leakage at the seat to a maximum allowable leak rate of 0.1 SCCM. The packing is tested for no detectable leakage.

**Panel mounting**

How to mount the valve on panel.



Panel Nut

Panel hole drill and thickness		mm (in)	
Valve Series	Panel Hole Drill	Panel Thickness	
		Min.	Max.
V15A	13.5 (0.53)	3.17 (0.125)	6.35 (0.25)
V15B	13.5 (0.53)		
V15C	20.0 (0.79)		
V15D	26.2 (1.03)		

- Remove the packing nut & panel nut and set aside for later use.
- Place the valve bonnet in the panel hole.

**Reassembly**

- Tighten the panel nut onto the valve bonnet.  
Keep the panel nut always on the external portion of the panel.
- Finger tighten the packing nut onto the valve body.
- Place the round handle on the stem. Align the set screw with the groove on the side of the stem. Tighten the set screw.
- Fully close the valve and retract the stem two or three turns before torque the packing nut to the torque below.

**Disassembly**

- Un-tighten the handle set screw using an allen key and remove the handle.

• Handle Set Screw Allen Key

Valve Series	Allen Key	
	Round Handle	Bar Handle
V15A & V15B	Hex.2.5mm	Hex. 4.0mm
V15C	Hex.3.0mm	
V15D		Hex. 5.0mm

• Packing Nut Torque Table

Valve Series	Torque	
	lbf · ft	kgf · cm
V15A, V15B	5.2	71.9
V15C	10.6	146.6
V15D	25.1	347

**Choice of Stem Tip**

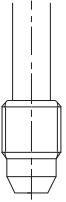
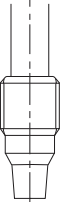
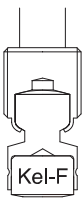
Vee Stem	Regulating Stem	Non-Rotating Soft Seat
		
Metal to metal Vee stem for pressure tightness at elevated temperature.	Regulating stem for flow rate control	Non-rotating PCTFE soft seat for repetitive shut-off on gas. • Round Handle is recommended for soft seat valve.

**Note :** Soft seat packing adjustment may be required during service to compensate the physical compression of soft seat after repeated shut-off.



**Ordering Information and Table of Dimensions**



Unit : mm (in.)

Valve Basic Ordering Number	End Connections		Orifice	Cv	Dimensions										
	Inlet	Outlet			A	B	L	L1	L2	E	D	H	H1		
V15A	F-2N-	1/8" Female NPT	2.0 (0.08)	0.09	60 (2.36)	21(0.83)	42(1.65)	21(0.83)		9.5 (0.37)	11 (0.43)	36 (1.42)	32 (1.26)		
	M-2N-	1/8" Male NPT						21(0.83)	20(0.79)						
	MD-2N2T	1/8" Male NPT   1/8" DK-Lok							26(1.02)						
	D-2T-	1/8" DK-Lok						26(1.02)	52(2.05)						
	D-3M-	3mm DK-Lok													
V15B	F-2N-	1/8" Female NPT	4.3 (0.17)	0.37	60 (2.36)	21(0.83)	42(1.65)	21(0.83)		9.5 (0.37)	11 (0.43)	36 (1.42)	45 (1.77)		
	M-2N-	1/8" Male NPT						25(0.98)	50(1.97)					25(0.98)	25(0.98)
	M-4N-	1/4" Male NPT							54(2.13)						28.8(1.13)
	MD-4N4T-	1/4" Male NPT   1/4" DK-Lok						29(1.14)	57.6(2.27)					28.8(1.13)	
	D-6M-	6mm DK-Lok													
	D-4T-	1/4" DK-Lok						30(1.18)	59.2(2.33)					29.6(1.16)	
	D-8M-	8mm DK-Lok													
V15C	F-4N-	1/4" Female NPT	6.4 (0.252)	0.73	71 (2.80)	28(1.10)	56(2.20)	28(1.10)	28(1.10)	13 (0.51)	13.5 (0.53)	50 (1.97)	64 (2.52)		
	F-4R-	1/4" Female ISO Tapered							33.2(1.31)						
	MF-4N-	1/4" Male NPT   1/4" Female NPT						61.2(2.41)	33.2(1.31)						
	MD-4N6T-	1/4" Male NPT   3/8" DK-Lok													
	M-6N-	3/8" Male NPT						29(1.14)	62.2(2.45)					29(1.14)	33.2(1.31)
	MD-6N6T-	3/8" Male NPT   3/8" DK-Lok													
	MD-6N8T-	3/8" Male NPT   1/2" DK-Lok						33(1.30)	66(2.60)					33.2(1.31)	33.2(1.31)
	D-10M-	10mm DK-Lok													
	D-6T-	3/8" DK-Lok						36(1.42)	72(2.83)					36(1.42)	36(1.42)
	D-12M-	12mm DK-Lok													
	D-8T-	1/2" DK-Lok													
V15D	F-6N-	3/8" Female NPT	9.5 (0.374)	1.80	99 (3.90)	38(1.50)	76(2.99)	38(1.50)	38(1.50)	19 (0.75)	19 (0.75)	66 (2.60)	76 (3.00)		
	F-6R-	3/8" Female ISO Tapered							48.5(1.91)						
	F-8N-	1/2" Female NPT													
	F-8R-	1/2" Female ISO Tapered						49(1.93)	97(3.82)						
	M-8N-	1/2" Male NPT													
	MF-8N-	1/2" Male NPT   1/2" Female NPT						48.5(1.91)							
	D-8T-	1/2" DK-Lok													
	D-12T-	3/4" DK-Lok													

All dimensions shown are for reference only and are subject to change. Dimensions with DK-Lok nuts are in finger-tight position. Patterns: To order angle pattern, use -A as a suffix to the valve ordering number. Example: V15A-F-2N-A

**Table 1. Pressure-Temperature Ratings for valves with standard PTFE packing**

Pressure rating of valves with PCTFE soft seat is limited to 200°F (93°C).

ASME Material Group	TABLE 2-2.2		N/A		TABLE 2-3.4		
	SS316		Brass		Alloy 400		
ASME Class Rating	2,080		N/A		1,500		
Temperature @ pressure	psig	bar	psig	bar	psig	bar	
-65F (-54°C) to	100°F (38°C)	5,000	345	3,000	207	3,000	207
	200°F (93°C)	4,293	296	2,353	162	2,640	182
	300°F (148°C)	3,877	267	2,059	142	2,470	170
	350°F (176°C)	3,719	256	1,471	101	2,430	167
	400°F (204°C)	3,562	246	392	27	2,390	165
	450°F (232°C)	3,437	237	-	-	2,380	164

**Note :** Pressure rating of valve may be limited to the working pressure of pipe ends and the tubing connected. Refer to DK-Lok Tube Fitting catalog for the details of working pressures in various tubing sizes, materials and wall thickness.

**Table 2. Pressure-Temperature Ratings for valves with optional PEEK packing**

Valve Material	Packing	Stem	Pressure –Temperature Rating °F (°C)
SS316	PEEK	Metal to metal (Vee & Regulating)	-65 to 600 (-54 to 315) @ 3,130 psig (215 bar)
Brass			-65 to 400 (-54 to 204) @ 3,000 psig (207 bar)
Alloy 400			-65 to 500 (-54 to 260) @ 2,370 psig (163 bar)

**Flow Curves**

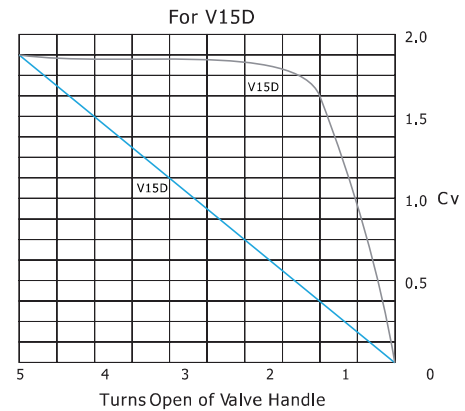
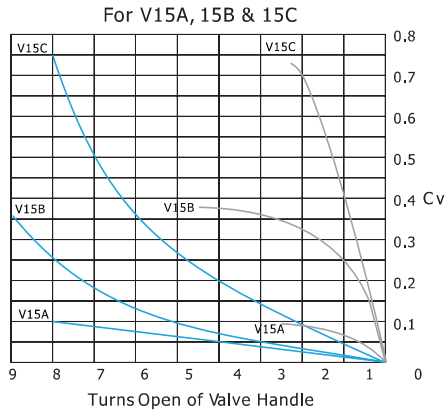

**How to order**

Select applicable Valve Pattern, Stem type, Handle and Body material from designators listed below.

V15B-F-2N  
V15B-F-2N

Valve Pattern	Stem Packing Designator	Stem Designator	Handle Designator	Body Material Designator
Nil : Inline pattern A : Angle pattern	Nil : Standard PTFE PK : PEEK	Nil : Standard Vee stem tip R : Regulating tip K : PCTFE (Kel-F) soft seat	Nil : Nylon Round Handle BH : Bar Handle	S : SS316 B : Brass M : Alloy 400
<b>Handle for Soft Seat</b> Nylon Round Handle is recommended for soft seat valve. This helps prevent the soft seat from damage.				

**We reserve the right to change specifications stated in this catalog for our continuing Program of improvement.**

**Safe Valve Selection**

The Selection of a Valve for any application or system design must be considered to ensure safe performance. Valve function, Valve rating, material compatibility, proper installation, operation and maintenance remain the sole responsibility of the system designer and the user. DK-Lok accepts no liability for any improper selection, installation, operation or maintenance.

# Nordstrom Screwed Gland-Type Iron Plug Valves

In screwed gland-type valves, controlled plug motion is provided by flexing of spring washers. Once the plug has been carefully adjusted by Nordstrom personnel during valve assembly, no adjustments are needed in the field.

The tapered plug is lapped individually with its matching body, providing perfect seating contact. The sealant channels in the plug and body seats provide lubrication,

which, together with the positive rotary action of the tapered-plug valve, protects the seating surfaces against corrosion, erosion, or accumulation of solid deposits.

Nordstrom screwed gland-type valves also offer a thermally bonded, low-friction plug coating for low operating torque, and sealant jacking to insure positive operation and drop-tight closure.

1. Wrench Flats
2. Slotted Fixed Adjustment Gland
3. O-ring Holder with O-rings
4. Flexible Metal Sealing Diaphragm and Gasket
5. Spring Washers
6. Plug
7. Sealant Fitting  
(Combination Sealant Screw and Giant Buttonhead Fitting)
8. Cover Cap Screw
9. Cover
10. Sealant Check Valve (not shown)  
(Double Ball-Check Prevents Escape of Sealant)
11. Sealant Grooves  
(Provides "Sealdport" Sealant System)
12. Sealant Chamber  
(Provides Plug "Jacking" Force)

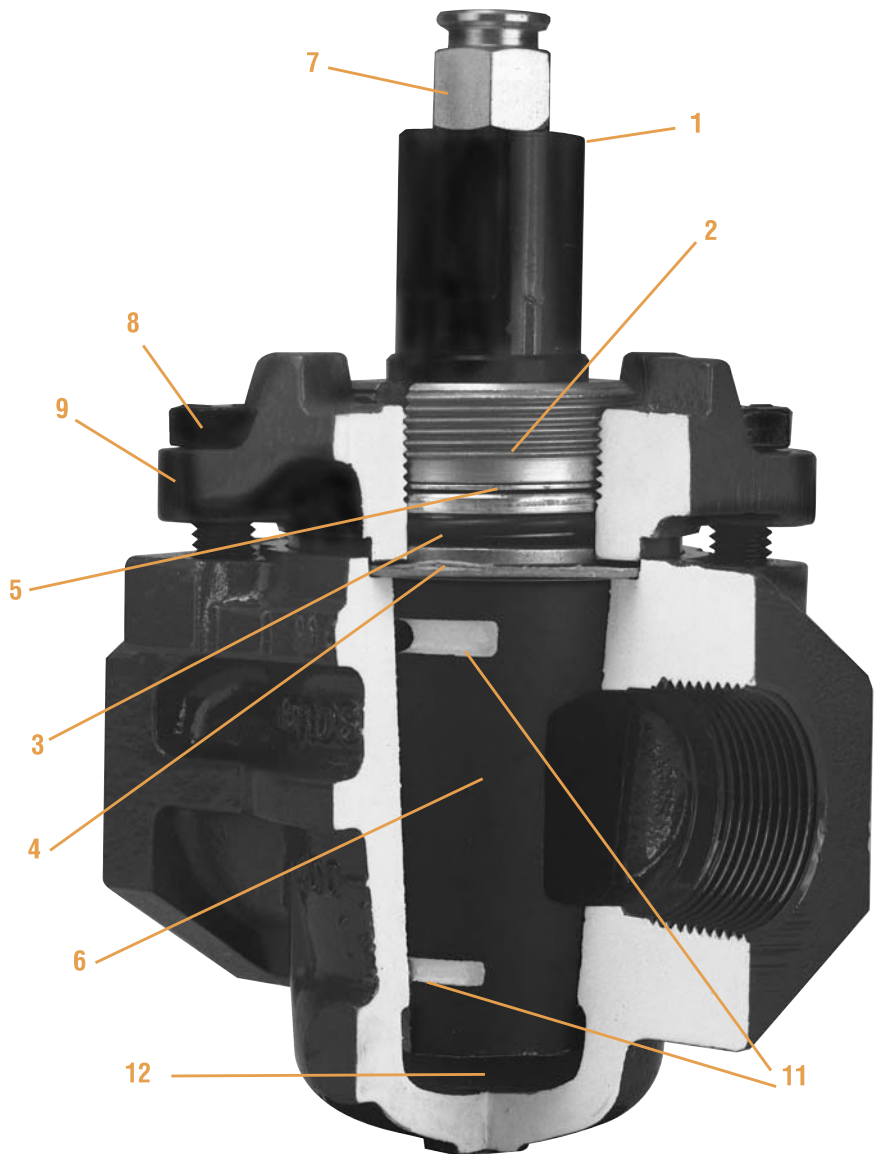



# Super Nordstrom Two-Bolt, Cover-Type Iron Plug Valves

## Short Pattern (Gate Length)

200 CWP (13.8 bar)

400 psig (27.6 bar) Test

Figure 142 – Threaded, Wrench-Operated, Sizes 1/2 to 4

Figure 143 – Flanged, Wrench-Operated, Sizes 1 to 5

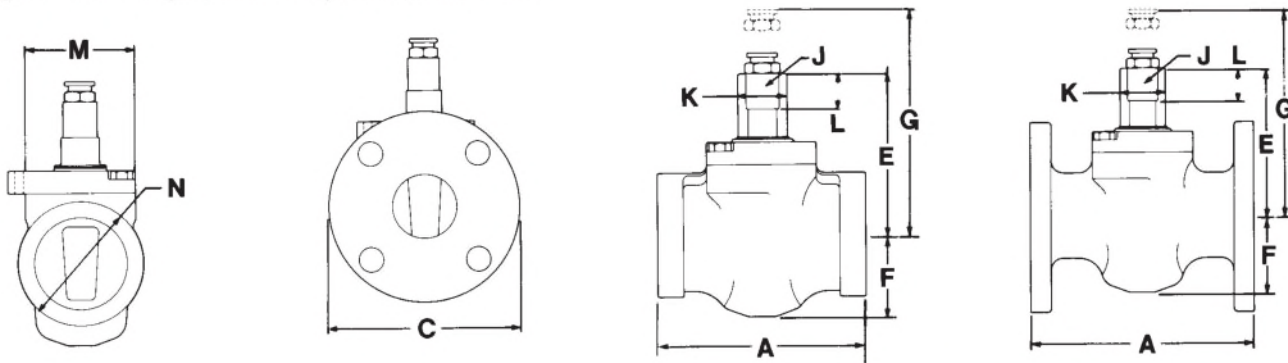

Size	NPS DN	½ 15	¾ 20	1 25	1¼ 32	1½ 40	2 50	2½ 65	3 80	4 100	5 125
End-to-end, threaded, Figure 142	A	4.50 114	4.50 114	4.50 114	5.00 127	5.00 127	5.88 149	7.00 178	7.62 194	9.00 229	
End-to-end, flanged, Figure 143	B			5.50 140	6.50 165	6.50 165	7.00 178	7.50 191	8.00 203	9.00 229	10.00 254
Diameter of flange	C			4.3 109	4.6 117	5.0 127	6.0 152	7.0 178	7.5 191	9.0 229	10.0 254
Center to top of stem	E	3.8 97	3.8 97	3.8 97	4.1 104	4.1 104	4.7 119	4.7 119	5.6 142	6.3 160	6.3 160
Center to bottom of body	F	1.9 48	1.9 48	1.9 48	2.1 53	2.1 53	2.4 61	2.4 61	3.4 86	4.0 102	4.0 102
Clearance required to remove sealant fitting	G	5.5 140	5.5 140	5.5 140	5.8 147	5.8 147	6.4 163	6.4 163	7.2 183	8.0 203	8.0 203
Width of stem flats	J	.81 21	.81 21	.81 21	1.00 25	1.00 25	1.00 25	1.00 25	1.25 32	1.25 32	1.25 32
Diameter of stem	K	1.06 27	1.06 27	1.06 27	1.38 35	1.38 35	1.38 35	1.38 35	1.75 44	1.75 44	1.75 44
Height of stem flats	L	.9 23	.9 23	.9 23	1.0 25	1.0 25	1.0 25	1.0 25	1.3 33	1.3 33	1.3 33
Extreme width of body, Figure 142	M	2.6 66	2.6 66	2.6 66	3.2 81	3.2 81	3.2 81	3.2 81	4.0 102	4.8 122	
Diameter of hub, Figure 142	N	2.3 58	2.3 58	2.3 58	2.9 74	2.9 74	3.6 91	4.3 109	5.2 132	6.4 163	
Size of Sealant Stick	—	B	B	B	B	B	B	B	B	B	B
Size of wrench	—	SN-1	SN-1	SN-1	SN-2	SN-2	SN-2	SN-2	SN-4*	SN-4*	SN-4*
Length of wrench	—	7.0 178	7.0 178	7.0 178	10.5 267	10.5 267	10.5 267	10.5 267	17.5 445	15.0 381	15.0 381
Weight (approx.) Figure 142	—	6 3	6 3	6 3	9 4	9 4	13 6	17 8	29 13	48 22	
Weight (approx.) Figure 143	—			9 4	14 6	14 6	20 9	25 11	38 17	65 29	80 36

Flanges are drilled to ANSI Class 125 Cast Iron Flange Standard Template. For drilling and bolting data, See page 40.

Figures 142 and 143 valves conform to the following standards where applicable: ANSI B1.20.1; ANSI B16.1; ANSI B16.10; API 5B; ASTM A126, Class B; and MSS SP-78. See page 34.

Figure 143 face-to-face lengths are interchangeable with ANSI Class 125 and API 175 CWP Cast Iron Gate Valves.

Figure 142 and 143 valves size 5 (125 mm) and smaller are not recommended for temperatures above +200°F (+93°C).

\* Use the longer SN-3 wrench for valves used in cold climates such as Canada.

# Nordstrom Bolted Gland-Type Iron Plug Valves

## Short Pattern (Gate Length)

200 CWP (13.8 bar)  
400 psig (27.6 bar) Test

Figure 143 – Flanged, Wrench-Operated, Sizes 6, 8 and 10

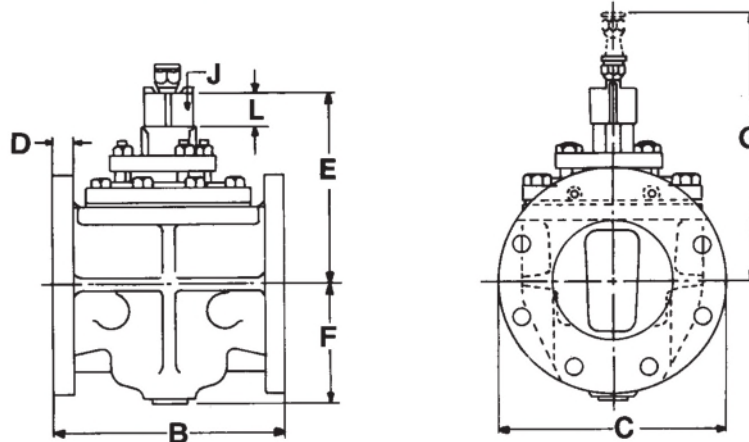

Size	NPS DN	6 150	8 200	10 250
Face-to-face, flanged, Figure 143	B	10.50 267	11.50 292	13.00 330
Diameter of flange	C	11.0 279	13.5 343	16.0 406
Thickness of flange	D	1.06 27	1.19 30	1.25 32
*No. and size of tapped holes in each flange	—	two 3/4"	two 3/4"	two 7/8"
Center to top of stem	E	9.6 244	11.9 302	14.2 361
Center to bottom of body	F	5.4 137	7.1 180	9.2 234
Clearance required to remove sealant fitting	G	13.6 345	16.9 429	19.2 488
Width of stem square	J	1.75 44	2.00 51	2.00 51
Height of stem square	L	1.8 46	2.0 51	2.1 53
Size of wrench	—	P-2	T-2	T-2
Length of wrench	—	27.0 686	36.0 914	36.0 914
Size of Sealant Stick	—	D	G	G
Weight (approx.) Figure 143	—	137 62	230 104	356 161

Flanges are drilled to ANSI Class 125 Cast Iron Flange Standard Template. For drilling and bolting data, See page 40.

Figure 143 valves conform to the following standards where applicable: ANSI B16.1; ANSI B16.10; ASTM A126, Class B; and MSS SP-78. See page 34.

Figure 143 face-to-face lengths are interchangeable with ANSI Class 125 and API 175 CWP Cast Iron Gate Valves.

\*Note: Studs or capscrews required. For sizes and lengths, see page 41.



# Quotation

**Date:** 3/19/2024  
**Attention:** Patty Maher  
**Company:** FLUID CONTROLS AND COMPONENTS INC  
**Address:** 3095 KINGSGATE WAY  
 RICHLAND, WA  
 99354  
 UNITED STATES  
**Phone:** (509) 375-0774  
**Email:** pmaher@dupillgroup.com  
**Description:** 6" V500, 2052, 3610J

**Quote#:**                      **Rev:** 1 **From:**

<b>Please Address Your Order To:</b>

**Shipping:** Best Way Parcel              **Delivery Terms:** Prepaid and Add              **Delivery Terms Location:** Shipping Point  
**Payment Terms:** Net 30              **Pricing Valid:** 30 Days

*A 4% convenience fee will be added for credit card payments. Please Note: We do not accept American Express.  
 Please note there is a \$30 minimum freight charge on all credit card orders.*

Applied Control is pleased to offer the following quotation for your consideration. Please carefully review materials of construction, conditions of service and all details, including specifications stated or on attachments, to verify our understanding of your requirements. Product availability and quoted lead times are subject to change prior to sale.

Item	Description	Qty	Unit Price	Total Price	Lead Time to Ship
1	NPS 6 V500 2052 Size 2 3610J	1			
	TAG: 03-LCV-9150				
2	NPS 6 V500 Repair Parts. Includes: Valve Plug, Drive Shaft, Seat Ring, Face Seals, Bearings and Packing Parts.	1			
			<b>Total:</b>		

UNLESS PREVIOUSLY NEGOTIATED TERMS AND CONDITIONS OF SALE BETWEEN BOTH PARTIES APPLY, THIS PROPOSAL INCORPORATES HEREIN AND MAKES A PART HEREOF BY REFERENCE "APPLIED CONTROL STANDARD TERMS AND CONDITIONS FOR THE SALE OF GOODS AND CONSULTING SERVICES" WHICH ARE AVAILABLE ON OUR WEBSITE AT <https://www.appliedcontrol.com/terms-and-conditions/> . BY PURCHASING OR ACCEPTING DELIVERY OF GOODS OR CONSULTING SERVICES PURSUANT TO THIS PROPOSAL THE BUYER AGREES TO BE BOUND BY APPLIED CONTROL. STANDARD TERMS AND CONDITIONS FOR THE SALE OF GOODS AND CONSULTING SERVICES UNLESS OTHERWISE AGREED TO IN WRITING BY BOTH PARTIES

Customer: **FLUID CONTROLS AND COMPONENTS INC**

Contact:

Customer Reference: **6" V500, 2052, 3610J**

Contact:

Sales Office Reference:

Item: **1**

Rev:

Qty: **1**Quote: **018-JF-240318-0233319 / Q394439**Lead Time: **22 Weeks**Tags: **03-LCV-9150**Description: **NPS 6 V500 2052 Size 2 3610J**Date Last Modified: **03/18/2024**Rev: **A**

Service Description:

Rotary Valves: **V500-816-7945245**Type: **V500**Valve Size: **NPS 6**Body Material: **WCC Steel**Body Insert Material: **Not App**NACE: **No**End Connection: **RF Flg**Rating: **CL150**Body Style: **Rotary Globe, Flanged**Port: **Restricted**Shaft Size: **1 1/4 Inch**Trim Number: **3**Bearing Style: **Standard**Bearing Material: **S44004 SST**Shaft Material: **S17400 SST**Packing Box: **Standard**Packing: **Graphite**Outboard End Tapping: **None**Lub-Iso Valve: **No**Pkg Box Studs & Nuts: **SA-193-B8M Str Hd Studs/8M Nuts**Flow: **Reverse**Face Seal Material: **N07718 Nickel Alloy**Internal Body Surface Coating: **None**Shaft Style: **Splined**Actuator Mounting: **Right Hand**Retainer Material: **R30006 Cobalt Alloy**Seat Ring Material: **R30006 Cobalt Alloy**Characteristic: **Modified Linear**Rotary Actuators: **2052-2507-374703**Actuator Size: **2**Operating Pressure: **4.0 barg (58 psig)**Mounting Adaption: **Style F**Shaft Size Group: **1 1/4 & 1 1/8 x 1 1/4 Inch**Shaft Style: **Splined**ISO 5211 Mounting Adaption: **Not App**Actuator Mounting: **Right Hand**Valve Action: **Push Down to Close**Mounting Style: **Style A**Rotary Actuator Mounting Position: **Pos 1**Top Mounted Handwheel: **No**Declutchable Manual Actuator: **No**Signal Connections: **1/4 NPT**Hub Mtd. Accessory Type: **None**Lockout: **No**Yoke & Travel Stop Bolting: **Steel**Casing Bolting Material: **18-8 SST**Low Ambient Temperature Construction: **No**Nameplate/Drive Screw Matr: **18-8 SST**Bushing Backing Material: **Steel**Actuator Style: **Spring & Diaphragm**Diaphragm Material: **NBR**Diaphragm Area: **73.6 in<sup>2</sup>**Spring Rate: **402.5 lb/in**Shutoff: **ANSI CL IV**Plug Material: **R30006 Cobalt Alloy**Seat Ring: **Not Reversible**Mounting Adaption: **Style F**Retainer Tool: **No**W.A.S: **A**Bonding Strap: **No**Supplemental Attribute: **Not App**

Pressure:

Temperature:

Manufacturer: **Fisher**

Shutoff Drop:

Flowing Drop:

Bonnet Style: **None**World Area Selections: **North America**Valve Type: **V500**

A Seating:

A Unseating:

A:

B:

C:

Degrees:

E:

F:

K:

Seal Material:

Valve Torque Direction:

Spring Number: **2 Springs 4 barg(58 psig)**Fails Valve: **Open**Valve Type: **V500**Shaft Size: **1 1/4 Inch**Ball/Plug/Disk Rotation: **CounterClockwise to Close**Actuator Max Rotation: **90 Deg**Supplemental Attribute: **Not App**Manufacturer: **Fisher**Supply: **Air**Stroke Speed Calculation: **Yes**Max Casing Pressure: **73 psig**Window Mtd Accessory Type: **None**

Ps:

Vo:

Vm:

Pf Exhaust:

Pi Exhaust:

Pf Fill:

Pi Fill:

Actuator Type: **2052**

Effective Diaphragm Area:

World Area Selections: **North America**

Initial Spring Set:

Max Manual Operator Torque:

Rotary Positioners: **3610-481-218916**

Action: **Direct**

Approval Agency - Approval: **ATEX - Group II Category 2 Gas and Dust**

Bypass: **No**

Gauges: **psig/MPa/bar**

Input Signal: **3 to 15 psig**

Operating Range: **4.0 to 5.0 barg (58 to 72 psig)**

Gauge Range: **Medium**

Actuator Size Range: **2**

Rotation: **90 Deg**

Cam: **A**

Flowscanner Hook-up: **No**

Tubing & Fitting Material: **3/8 Inch 316 SST/SST Swagelok**

Supply Reg/Filter: **67CFR Filter/Regulator**

H800 Relief Valve: **No**

Pneumatic Instrument: **Not App**

Operating Range Group: **0 to 72 psig**

Mounting Parts: **Yes**

Factory Mounted: **Yes**

Actuator Type: **2052**

Actuator Size: **2**

Shaft Size: **1 1/4 Inch**

Rotary Actuator Mounting Position: **Pos 1**

Accessory Mounting Position: **Positioner 1**

Supply Reg/Filter Mounting Position: **Yoke 1**

Safety Related (CGID): **No**

Supplemental Attribute: **Not App**

Type: **3610J**

Manufacturer: **Fisher**

Positioner Style: **P/P**

ACTUATOR ORIENTATION

RIGHT-HAND  
MOUNTING  
POSITION 1  
STYLE A

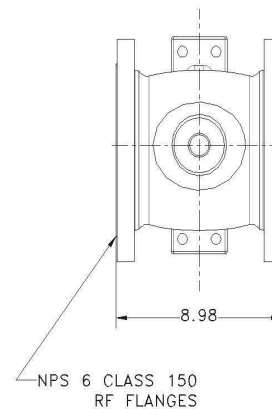
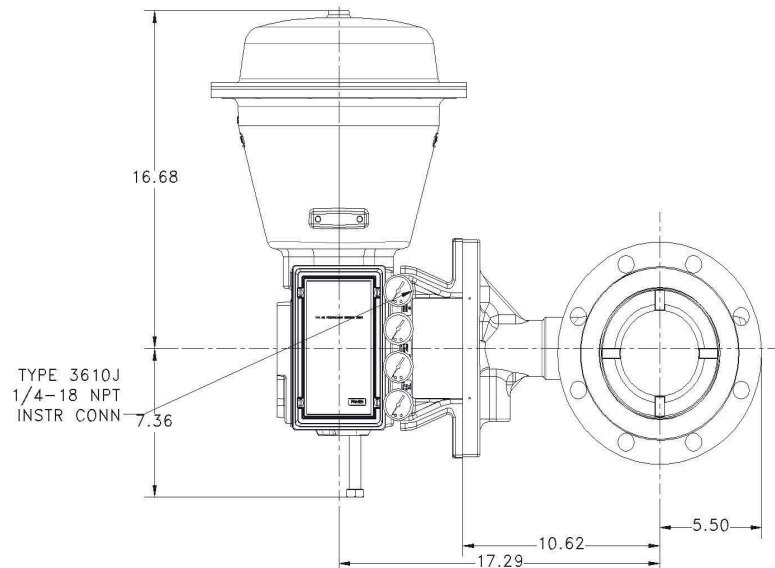
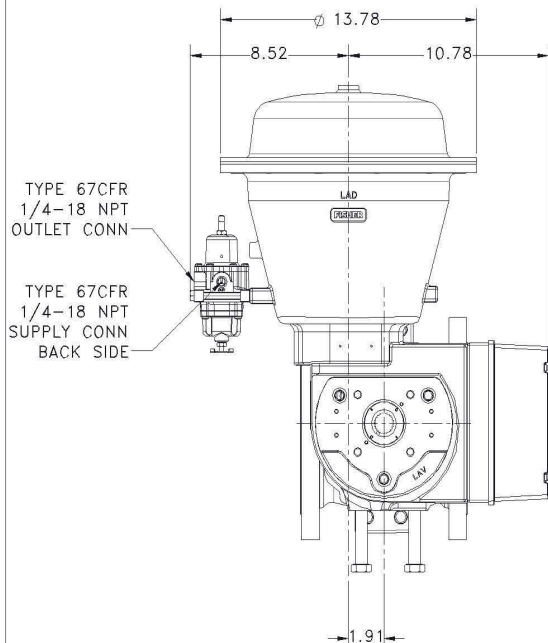
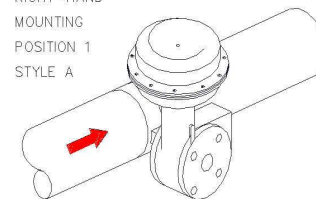

DIMENSIONS CERTIFIED CORRECT BY FISHER CONTROLS



© Fisher Controls Intl. LLC 2024

CUST: FLUID CONTROLS AND COMPONENTS INC  
CUST REF NO.: 6" V500, 2052, 3610J  
FISHER REF NO.: 018-JF-240318-0233319  
TAG NO.: 03-LCV-9150  
PROJECT NAME:

V500 VALVE BODY SIZE 6  
2052 ACTUATOR SIZE 2

CUST ITEM: 0001

S.NO.:

TOTAL CALCULATED Wt +/- 10%  
TOTAL WEIGHT: 254.4 lb  
UNLESS OTHERWISE SPECIFIED  
UNIT OF MEASURE: INCH

REV	DATE	DWN.	CHKD.	APVD.
A	18-Mar-24	FDS		
GENERAL ARRANGEMENT				

SCALE: NONE

DWG. NO. REV. A

SHEET 1 OF 1





**Agenda Sheet for City Council:**

**Committee:** PIES **Date:** 05/20/2024

**Committee Agenda type:** Consent

**Date Rec'd** 5/20/2024

**Clerk's File #** OPR 2023-0896

**Cross Ref #**

**Project #**

**Council Meeting Date:** 06/10/2024

<b>Submitting Dept</b>	SOLID WASTE DISPOSAL	<b>Bid #</b>	PW ITB 5918-23
------------------------	----------------------	--------------	----------------

<b>Contact Name/Phone</b>	DAVID PAINE 625-6878	<b>Requisition #</b>	CR 26326
---------------------------	----------------------	----------------------	----------

<b>Contact E-Mail</b>	DPAINE@SPOKANECITY.ORG		
-----------------------	------------------------	--	--

<b>Agenda Item Type</b>	Contract Item		
-------------------------	---------------	--	--

<b>Council Sponsor(s)</b>	BWILKERSON JBINGLE KKLITZKE		
---------------------------	-----------------------------	--	--

<b>Agenda Item Name</b>	4490 AMENDMENT WITH COST FOR BOILER FEEDWATER PUMP SERVICES		
-------------------------	---	--	--

**Agenda Wording**

Contract amendment with cost with Bender CCP, Inc. (Portland, OR) for as-needed boiler feedwater pump services at the Waste to Energy Facility from 9/1/23-8/31/24. An additional \$200,000.00 is needed for a total cost of \$300,000.00, plus tax.

**Summary (Background)**

The Waste to Energy Facility utilizes feedwater pumps to supply water to the boilers to be converted into high pressure steam. Based on their response to PW ITB 5918-23, Bender CCP, Inc. was awarded a one year contract with the option of three additional one-year renewals for the service of these pumps. Due to unanticipated repairs required on more than one pump, more funding is needed to cover those repairs and any other needed services that may arise prior to the end of the contract term.

Lease? NO Grant related? NO Public Works? YES

**Fiscal Impact**

Approved in Current Year Budget? YES

Total Cost	\$ \$300,000.00
------------	-----------------

Current Year Cost	\$ \$300,000.00
-------------------	-----------------

Subsequent Year(s) Cost	\$ 0
-------------------------	------

**Narrative**

This is an unanticipated repair and maintenance cost. The additional funds needed for this will be offset by deferring other projects planned for in the 2024 Solid Waste Disposal budget.

**Amount**

**Budget Account**

Expense	\$ 200,000.00	# 4490-44100-37148-54803-34002
Select	\$	#
Select	\$	#
Select	\$	#
	\$	#
	\$	#





## Committee Agenda Sheet

### Public Infrastructure, Environment & Sustainability Committee

<b>Committee Date</b>	May 20, 2024
<b>Submitting Department</b>	Solid Waste Disposal
<b>Contact Name</b>	David Paine
<b>Contact Email &amp; Phone</b>	<a href="mailto:dpaine@spokanecity.org">dpaine@spokanecity.org</a> , 509-625-6878
<b>Council Sponsor(s)</b>	Wilkerson, Bingle, Klitzke
<b>Select Agenda Item Type</b>	<input checked="" type="checkbox"/> Consent <input type="checkbox"/> Discussion    Time Requested:
<b>Agenda Item Name</b>	Contract amendment with cost for as-needed boiler feedwater pump maintenance and repairs at the Waste to Energy Facility.
<b>Proposed Council Action</b>	<input checked="" type="checkbox"/> Approval to proceed to Legislative Agenda <input type="checkbox"/> Information Only
<b>Summary (Background)</b>  *use the Fiscal Impact box below for relevant financial information	<p>The Waste to Energy Facility utilizes Sulzer Pumps in its operation of the facility to supply water to the boilers to be converted into high pressure steam.</p> <p>On June 26, 2023 bidding closed on PW ITB 5918-23 for the as-needed service of these pumps. Responses were received from Flowserve US Inc., Bender CCP Inc. and McKinstry. Bender CCP, Inc. was selected as the low-cost, responsible bidder. The contract award was for one year, from September 1, 2023 through August 31, 2024, with the option of three additional one-year renewals. The total annual cost was not to exceed \$100,000.00 plus tax.</p> <p>Unfortunately, one pump has already required more than \$50,000.00 in repairs in 2024, and another pump now requires another \$100,000.00 in repairs. In an effort to cover the cost of these additional repairs and have funds available for any other maintenance or repairs that may arise, an additional \$200,000.00 is being requested, for a total annual cost of \$300,000.00 plus tax.</p>
<b>Fiscal Impact</b> <b>Approved in current year budget?</b> <input checked="" type="checkbox"/> Yes <input type="checkbox"/> No <input type="checkbox"/> N/A Total Cost: <u>\$200,000.00 additional for a total annual cost of \$300,000.00 plus tax.</u> Current year cost: \$300,000.00 Subsequent year(s) cost:	
<b>Narrative:</b> <u>This is an unanticipated repair and maintenance cost. The additional funds needed for this will be offset by deferring other projects planned for in the 2024 Solid Waste Disposal budget.</u>	
<b>Funding Source</b> <input type="checkbox"/> One-time <input checked="" type="checkbox"/> Recurring <input type="checkbox"/> N/A Specify funding source: Program revenue Is this funding source sustainable for future years, months, etc? Yes	
<b>Expense Occurrence</b> <input checked="" type="checkbox"/> One-time <input type="checkbox"/> Recurring <input type="checkbox"/> N/A  Other budget impacts: (revenue generating, match requirements, etc.)	
<b>Operations Impacts (If N/A, please give a brief description as to why)</b> <ul style="list-style-type: none"> <li>• What impacts would the proposal have on historically excluded communities?</li> </ul>	

Public works services and projects are designed to serve all citizens and businesses. We strive to offer a consistent level of service to all, to distribute public investment throughout the community and to respond to gaps in services identified in various City plans.

- How will data be collected, analyzed, and reported concerning the effect of the program/policy by racial, ethnic, gender identity, national origin, income level, disability, sexual orientation, or other existing disparities?

N/A

- How will data be collected regarding the effectiveness of this program, policy, or product to ensure it is the right solution?

Public Works follows the City's established procurement and public works bidding regulations and policies to bring items forward, and then uses contract management best practices to ensure desired outcomes and regulatory compliance.

- Describe how this proposal aligns with current City Policies, including the Comprehensive Plan, Sustainability Action Plan, Capital Improvement Program, Neighborhood Master Plans, Council Resolutions, and others?

This work is consistent with annual budget strategies to limit costs and approved projects in the 6-year CIP.

#### **Council Subcommittee Review**

- Please provide a summary of council subcommittee review. If not reviewed by a council subcommittee, please explain why not.

Not applicable



**City of Spokane**  
**CONTRACT AMENDMENT**  
Title: **AS-NEEDED PUMP REPAIR**

This Contract Amendment is made and entered into by and between the **CITY OF SPOKANE** as (“City”), a Washington municipal corporation, and **BENDER CCP, INC.**, whose address is 2315 NW 21st Place, Portland, Oregon 97210 as (“Contractor”), individually hereafter referenced as a “party”, and together as the “parties”.

*WHEREAS, the parties entered into a Contract wherein the Contractor agreed to provide Sulzer Boiler Feed Water Pumps On-Site and Off-Site As-Need Maintenance and Repair Services at the Waste to Energy Facility; and*

*WHEREAS, additional funds are necessary due to unanticipated work need on multiple pumps, thus, the original Contract needs to be formally amended by this written document; and*

*NOW, THEREFORE, in consideration of these terms, the parties mutually agree as follows:*

**1. CONTRACT DOCUMENTS.**

The Contract, dated September 20, 2023 and October 5, 2023, any previous amendments, addendums and / or extensions / renewals thereto, are incorporated by reference into this document as though written in full and shall remain in full force and effect except as provided herein.

**2. EFFECTIVE DATE.**

This Contract Amendment shall become effective on September 1, 2023.

**3. COMPENSATION.**

The City shall pay an additional amount not to exceed **TWO HUNDRED THOUSAND AND NO/100 DOLLARS (\$200,000.00)** not including tax, for everything furnished and done under this Contract Amendment. This is the maximum amount to be paid under this Amendment, and shall not be exceeded without the prior written authorization of the City, memorialized with the same formality as the original Contract and this document.

IN WITNESS WHEREOF, in consideration of the terms, conditions and covenants contained, or attached and incorporated and made a part, the parties have executed

this Contract Amendment by having legally-binding representatives affix their signatures below.

**BENDER CCP, INC.**

**CITY OF SPOKANE**

By \_\_\_\_\_  
Signature Date

By \_\_\_\_\_  
Signature Date

\_\_\_\_\_  
Type or Print Name

\_\_\_\_\_  
Type or Print Name

\_\_\_\_\_  
Title

\_\_\_\_\_  
Title

Attest:

Approved as to form:

\_\_\_\_\_  
City Clerk

\_\_\_\_\_  
Assistant City Attorney

24-087



# CERTIFICATE OF LIABILITY INSURANCE

DATE (MM/DD/YYYY)

3/9/2024

THIS CERTIFICATE IS ISSUED AS A MATTER OF INFORMATION ONLY AND CONFERS NO RIGHTS UPON THE CERTIFICATE HOLDER. THIS CERTIFICATE DOES NOT AFFIRMATIVELY OR NEGATIVELY AMEND, EXTEND OR ALTER THE COVERAGE AFFORDED BY THE POLICIES BELOW. THIS CERTIFICATE OF INSURANCE DOES NOT CONSTITUTE A CONTRACT BETWEEN THE ISSUING INSURER(S), AUTHORIZED REPRESENTATIVE OR PRODUCER, AND THE CERTIFICATE HOLDER.

**IMPORTANT:** If the certificate holder is an **ADDITIONAL INSURED**, the policy(ies) must have **ADDITIONAL INSURED** provisions or be endorsed. If **SUBROGATION IS WAIVED**, subject to the terms and conditions of the policy, certain policies may require an endorsement. A statement on this certificate does not confer rights to the certificate holder in lieu of such endorsement(s).

<b>PRODUCER</b> Arthur J. Gallagher Risk Management Services, LLC 2121 N. California Blvd., Suite 350 Walnut Creek CA 94596	<b>CONTACT NAME:</b> Certificate Department <b>PHONE (A/C. No. Ext):</b> 925-299-1112 <b>E-MAIL ADDRESS:</b> GSC_Construction_Certrequests@AJG.com	<b>FAX (A/C. No):</b> 925-925-0328
	<b>INSURER(S) AFFORDING COVERAGE</b>	
License#: 0D69293 VERNMAC-01	<b>INSURER A:</b> Indian Harbor Insurance Company	<b>NAIC #</b> 36940
<b>INSURED</b> Bender CCP, Inc. 2150 East 37th Street Vernon CA 90058	<b>INSURER B:</b> Hartford Casualty Insurance Company	29424
	<b>INSURER C:</b> Hartford Accident and Indemnity Company	22357
	<b>INSURER D:</b> Travelers Property Casualty Insurance Co	36161
	<b>INSURER E:</b> The Travelers Indemnity Company of CT	25682
	<b>INSURER F:</b>	

**COVERAGES** **CERTIFICATE NUMBER: 519133439** **REVISION NUMBER:**

THIS IS TO CERTIFY THAT THE POLICIES OF INSURANCE LISTED BELOW HAVE BEEN ISSUED TO THE INSURED NAMED ABOVE FOR THE POLICY PERIOD INDICATED. NOTWITHSTANDING ANY REQUIREMENT, TERM OR CONDITION OF ANY CONTRACT OR OTHER DOCUMENT WITH RESPECT TO WHICH THIS CERTIFICATE MAY BE ISSUED OR MAY PERTAIN, THE INSURANCE AFFORDED BY THE POLICIES DESCRIBED HEREIN IS SUBJECT TO ALL THE TERMS, EXCLUSIONS AND CONDITIONS OF SUCH POLICIES. LIMITS SHOWN MAY HAVE BEEN REDUCED BY PAID CLAIMS.

INSR LTR	TYPE OF INSURANCE	ADDL INSD	SUBR WVD	POLICY NUMBER	POLICY EFF (MM/DD/YYYY)	POLICY EXP (MM/DD/YYYY)	LIMITS
D	<input checked="" type="checkbox"/> <b>COMMERCIAL GENERAL LIABILITY</b> <input type="checkbox"/> CLAIMS-MADE <input checked="" type="checkbox"/> OCCUR GEN'L AGGREGATE LIMIT APPLIES PER: <input checked="" type="checkbox"/> POLICY <input checked="" type="checkbox"/> PRO-JECT <input type="checkbox"/> LOC OTHER:	Y	Y	Y-660-4W505673-TIL-24	3/10/2024	3/10/2025	EACH OCCURRENCE \$ 1,000,000 DAMAGE TO RENTED PREMISES (Ea occurrence) \$ 300,000 MED EXP (Any one person) \$ 5,000 PERSONAL & ADV INJURY \$ 1,000,000 GENERAL AGGREGATE \$ 2,000,000 PRODUCTS - COMP/OP AGG \$ 2,000,000 Employee Benefits \$ 1,000,000
E	<input checked="" type="checkbox"/> <b>AUTOMOBILE LIABILITY</b> <input checked="" type="checkbox"/> ANY AUTO <input type="checkbox"/> OWNED AUTOS ONLY <input type="checkbox"/> SCHEDULED AUTOS <input checked="" type="checkbox"/> HIRED AUTOS ONLY <input type="checkbox"/> NON-OWNED AUTOS ONLY <input checked="" type="checkbox"/> Comp \$1,000 <input checked="" type="checkbox"/> Coll \$1,000	Y	Y	810-4W504246-24-14-G	3/10/2024	3/10/2025	COMBINED SINGLE LIMIT (Ea accident) \$ 1,000,000 BODILY INJURY (Per person) \$ BODILY INJURY (Per accident) \$ PROPERTY DAMAGE (Per accident) \$ \$
B	<input type="checkbox"/> <b>UMBRELLA LIAB</b> <input checked="" type="checkbox"/> OCCUR <input checked="" type="checkbox"/> <b>EXCESS LIAB</b> <input type="checkbox"/> CLAIMS-MADE DED <input checked="" type="checkbox"/> RETENTION \$ 0	Y		CUP-4W505925-24-14	3/10/2024	3/10/2025	EACH OCCURRENCE \$ 10,000,000 AGGREGATE \$ 10,000,000 \$
C	<input checked="" type="checkbox"/> <b>WORKERS COMPENSATION AND EMPLOYERS' LIABILITY</b> ANY PROPRIETOR/PARTNER/EXECUTIVE OFFICER/MEMBER EXCLUDED? (Mandatory in NH) If yes, describe under DESCRIPTION OF OPERATIONS below	Y/N	N/A	UB-4W50450A-24-14-G	3/10/2024	3/10/2025	<input checked="" type="checkbox"/> PER STATUTE <input type="checkbox"/> OTH-ER E.L. EACH ACCIDENT \$ 1,000,000 E.L. DISEASE - EA EMPLOYEE \$ 1,000,000 E.L. DISEASE - POLICY LIMIT \$ 1,000,000
A	Pollution Liability			PEC003714112	3/10/2024	3/10/2025	Each Occurrence \$10,00,000 Aggregate \$10,000,000

**DESCRIPTION OF OPERATIONS / LOCATIONS / VEHICLES (ACORD 101, Additional Remarks Schedule, may be attached if more space is required)**

Excess/Umbrella follows form over the General Liability, Automobile and Employers Liability policies  
 RE: Bid Number PW ITB 5918-23; Sulzer Boiler Feed Water Pumps On-site and Off-site "as needed" Maintenance and Repair Services – Public Works Maintenance – On Call; Bender job # 221-1363; Customer PO # 126924 REV.#2; S2022 Unit 2B Boiler Feed Pump Rebuild; Project Location: FS – Springerville Generating Station, Springerville, AZ; Shop – Bender CCP's Vernon, CA facility; Solid Waste Disposal **ADDITIONAL INSURED(S):** City of Spokane, its officers and employees, all of the parties

**CERTIFICATE HOLDER** **CANCELLATION**

City of Spokane 808 W. Spokane Falls Blvd. Spokane WA 99201	SHOULD ANY OF THE ABOVE DESCRIBED POLICIES BE CANCELLED BEFORE THE EXPIRATION DATE THEREOF, NOTICE WILL BE DELIVERED IN ACCORDANCE WITH THE POLICY PROVISIONS.  <b>AUTHORIZED REPRESENTATIVE</b> 
---	--

© 1988-2015 ACORD CORPORATION. All rights reserved.

**THIS ENDORSEMENT CHANGES THE POLICY. PLEASE READ IT CAREFULLY.**

**BLANKET ADDITIONAL INSURED**  
**(Includes Products-Completed Operations If Required By Contract)**

This endorsement modifies insurance provided under the following:  
 COMMERCIAL GENERAL LIABILITY COVERAGE PART

**PROVISIONS**

The following is added to **SECTION II – WHO IS AN INSURED**:

Any person or organization that you agree in a written contract or agreement to include as an additional insured on this Coverage Part is an insured, but only:

- a. With respect to liability for "bodily injury" or "property damage" that occurs, or for "personal injury" caused by an offense that is committed, subsequent to the signing of that contract or agreement and while that part of the contract or agreement is in effect; and
- b. If, and only to the extent that, such injury or damage is caused by acts or omissions of you or your subcontractor in the performance of "your work" to which the written contract or agreement applies. Such person or organization does not qualify as an additional insured with respect to the independent acts or omissions of such person or organization.

The insurance provided to such additional insured is subject to the following provisions:

- a. If the Limits of Insurance of this Coverage Part shown in the Declarations exceed the minimum limits required by the written contract or agreement, the insurance provided to the additional insured will be limited to such minimum required limits. For the purposes of determining whether this limitation applies, the minimum limits required by the written contract or agreement will be considered to include the minimum limits of any Umbrella or Excess liability coverage required for the additional insured by that written contract or agreement. This provision will not increase the limits of insurance described in Section III – Limits Of Insurance.
- b. The insurance provided to such additional insured does not apply to:

- (1) Any "bodily injury", "property damage" or "personal injury" arising out of the providing, or failure to provide, any professional architectural, engineering or surveying services, including:

- (a) The preparing, approving, or failing to prepare or approve, maps, shop drawings, opinions, reports, surveys, field orders or change orders, or the preparing, approving, or failing to prepare or approve, drawings and specifications; and

- (b) Supervisory, inspection, architectural or engineering activities.

- (2) Any "bodily injury" or "property damage" caused by "your work" and included in the "products-completed operations hazard" unless the written contract or agreement specifically requires you to provide such coverage for that additional insured during the policy period.

- c. The additional insured must comply with the following duties:

- (1) Give us written notice as soon as practicable of an "occurrence" or an offense which may result in a claim. To the extent possible, such notice should include:

- (a) How, when and where the "occurrence" or offense took place;

- (b) The names and addresses of any injured persons and witnesses; and

- (c) The nature and location of any injury or damage arising out of the "occurrence" or offense.

- (2) If a claim is made or "suit" is brought against the additional insured:

- (a) Immediately record the specifics of the claim or "suit" and the date received; and
- (b) Notify us as soon as practicable and see to it that we receive written notice of the claim or "suit" as soon as practicable.
- (3) Immediately send us copies of all legal papers received in connection with the claim or "suit", cooperate with us in the investigation or settlement of the claim or defense against the "suit", and otherwise comply with all policy conditions.
- (4) Tender the defense and indemnity of any claim or "suit" to any provider of other insurance which would cover such additional insured for a loss we cover. However, this condition does not affect whether the insurance provided to such additional insured is primary to other insurance available to such additional insured which covers that person or organization as a named insured as described in Paragraph 4., Other Insurance, of Section IV – Commercial General Liability Conditions.

**THIS ENDORSEMENT CHANGES THE POLICY. PLEASE READ IT CAREFULLY.**

## **XTEND ENDORSEMENT FOR MANUFACTURERS AND WHOLESALEERS**

This endorsement modifies insurance provided under the following:

### **COMMERCIAL GENERAL LIABILITY COVERAGE PART**

**GENERAL DESCRIPTION OF COVERAGE** – This endorsement broadens coverage. However, coverage for any injury, damage or medical expenses described in any of the provisions of this endorsement may be excluded or limited by another endorsement to this Coverage Part, and these coverage broadening provisions do not apply to the extent that coverage is excluded or limited by such an endorsement. The following listing is a general coverage description only. Read all the provisions of this endorsement and the rest of your policy carefully to determine rights, duties, and what is and is not covered.

- |  |  |
|--|--|
| <ul style="list-style-type: none"> <li><b>A.</b> Who Is An Insured – Unnamed Subsidiaries</li> <li><b>B.</b> Who Is An Insured – Employees And Volunteer Workers – Bodily Injury To Co-Employees And Co-Volunteer Workers</li> <li><b>C.</b> Who Is An Insured – Newly Acquired Or Formed Limited Liability Companies</li> <li><b>D.</b> Blanket Additional Insured – Broad Form Vendors</li> <li><b>E.</b> Blanket Additional Insured – Controlling Interest</li> <li><b>F.</b> Blanket Additional Insured – Mortgagees, Assignees, Successors Or Receivers</li> <li><b>G.</b> Blanket Additional Insured – Governmental Entities – Permits Or Authorizations Relating To Premises</li> </ul> | <ul style="list-style-type: none"> <li><b>H.</b> Blanket Additional Insured – Governmental Entities – Permits Or Authorizations Relating To Operations</li> <li><b>I.</b> Blanket Additional Insured – Grantors Of Franchises</li> <li><b>J.</b> Incidental Medical Malpractice</li> <li><b>K.</b> Medical Payments – Increased Limit</li> <li><b>L.</b> Blanket Waiver Of Subrogation</li> <li><b>M.</b> Contractual Liability – Railroads</li> </ul> |
|--|--|

### **PROVISIONS**

#### **A. WHO IS AN INSURED – UNNAMED SUBSIDIARIES**

The following is added to **SECTION II – WHO IS AN INSURED**:

Any of your subsidiaries, other than a partnership or joint venture, that is not shown as a Named Insured in the Declarations is a Named Insured if:

- a.** You are the sole owner of, or maintain an ownership interest of more than 50% in, such subsidiary on the first day of the policy period; and
- b.** Such subsidiary is not an insured under similar other insurance.

No such subsidiary is an insured for "bodily injury" or "property damage" that occurred, or "personal and advertising injury" caused by an offense committed:

- a.** Before you maintained an ownership interest of more than 50% in such subsidiary; or
- b.** After the date, if any, during the policy period that you no longer maintain an ownership interest of more than 50% in such subsidiary.

For purposes of Paragraph 1. of Section II – Who Is An Insured, each such subsidiary will be deemed to be designated in the Declarations as:

- a.** A limited liability company;
  - b.** An organization other than a partnership, joint venture or limited liability company; or
  - c.** A trust;
- as indicated in its name or the documents that govern its structure.



**B. WHO IS AN INSURED – EMPLOYEES AND VOLUNTEER WORKERS – BODILY INJURY TO CO-EMPLOYEES AND CO-VOLUNTEER WORKERS**

The following is added to Paragraph 2.a.(1) of SECTION II – WHO IS AN INSURED:

Paragraphs (1)(a), (b) and (c) above do not apply to "bodily injury" to a co-"employee" while in the course of the co-"employee's" employment by you or performing duties related to the conduct of your business, or to "bodily injury" to your other "volunteer workers" while performing duties related to the conduct of your business.

**C. WHO IS AN INSURED – NEWLY ACQUIRED OR FORMED LIMITED LIABILITY COMPANIES**

The following replaces Paragraph 3. of SECTION II – WHO IS AN INSURED:

3. Any organization you newly acquire or form, other than a partnership or joint venture, and of which you are the sole owner or in which you maintain an ownership interest of more than 50%, will qualify as a Named Insured if there is no other similar insurance available to that organization. However:

- a. Coverage under this provision is afforded only:
  - (1) Until the 180th day after you acquire or form the organization or the end of the policy period, whichever is earlier, if you do not report such organization in writing to us within 180 days after you acquire or form it; or
  - (2) Until the end of the policy period, when that date is later than 180 days after you acquire or form such organization, if you report such organization in writing to us within 180 days after you acquire or form it;
- b. Coverage A does not apply to "bodily injury" or "property damage" that occurred before you acquired or formed the organization; and
- c. Coverage B does not apply to "personal and advertising injury" arising out of an offense committed before you acquired or formed the organization.

For the purposes of Paragraph 1. of Section II – Who Is An Insured, each such organization will be deemed to be designated in the Declarations as:

- a. A limited liability company;
  - b. An organization, other than a partnership, joint venture or limited liability company; or
  - c. A trust;
- as indicated in its name or the documents that govern its structure.

**D. BLANKET ADDITIONAL INSURED – BROAD FORM VENDORS**

The following is added to SECTION II – WHO IS AN INSURED:

Any person or organization that is a vendor and that you have agreed in a written contract or agreement to include as an additional insured on this Coverage Part is an insured, but only with respect to liability for "bodily injury" or "property damage" that:

- a. Occurs subsequent to the signing of that contract or agreement; and
- b. Arises out of "your products" that are distributed or sold in the regular course of such vendor's business.

The insurance provided to such vendor is subject to the following provisions:

- a. The limits of insurance provided to such vendor will be the minimum limits that you agreed to provide in the written contract or agreement, or the limits shown in the Declarations, whichever are less.
- b. The insurance provided to such vendor does not apply to:
  - (1) Any express warranty not authorized by you or any distribution or sale for a purpose not authorized by you;
  - (2) Any change in "your products" made by such vendor;
  - (3) Repackaging, unless unpacked solely for the purpose of inspection, demonstration, testing, or the substitution of parts under instructions from the manufacturer, and then repackaged in the original container;
  - (4) Any failure to make such inspections, adjustments, tests or servicing as vendors agree to perform or normally undertake to perform in the regular course of business, in connection with the distribution or sale of "your products";

- (5) Demonstration, installation, servicing or repair operations, except such operations performed at such vendor's premises in connection with the sale of "your products"; or
- (6) "Your products" that, after distribution or sale by you, have been labeled or relabeled or used as a container, part or ingredient of any other thing or substance by or on behalf of such vendor.

Coverage under this provision does not apply to:

- a. Any person or organization from whom you have acquired "your products", or any ingredient, part or container entering into, accompanying or containing such products; or
- b. Any vendor for which coverage as an additional insured specifically is scheduled by endorsement.

**E. BLANKET ADDITIONAL INSURED – CONTROLLING INTEREST**

1. The following is added to **SECTION II – WHO IS AN INSURED**:

Any person or organization that has financial control of you is an insured with respect to liability for "bodily injury", "property damage" or "personal and advertising injury" that arises out of:

- a. Such financial control; or
- b. Such person's or organization's ownership, maintenance or use of premises leased to or occupied by you.

The insurance provided to such person or organization does not apply to structural alterations, new construction or demolition operations performed by or on behalf of such person or organization.

2. The following is added to Paragraph 4. of **SECTION II – WHO IS AN INSURED**:

This paragraph does not apply to any premises owner, manager or lessor that has financial control of you.

**F. BLANKET ADDITIONAL INSURED – MORTGAGEES, ASSIGNEES, SUCCESSORS OR RECEIVERS**

The following is added to **SECTION II – WHO IS AN INSURED**:

Any person or organization that is a mortgagee, assignee, successor or receiver and that you have agreed in a written contract or agreement to include as an additional insured on this Coverage Part is an insured, but only with respect to its

liability as mortgagee, assignee, successor or receiver for "bodily injury", "property damage" or "personal and advertising injury" that:

- a. Is "bodily injury" or "property damage" that occurs, or is "personal and advertising injury" caused by an offense that is committed, subsequent to the signing of that contract or agreement; and
- b. Arises out of the ownership, maintenance or use of the premises for which that mortgagee, assignee, successor or receiver is required under that contract or agreement to be included as an additional insured on this Coverage Part.

The insurance provided to such mortgagee, assignee, successor or receiver is subject to the following provisions:

- a. The limits of insurance provided to such mortgagee, assignee, successor or receiver will be the minimum limits that you agreed to provide in the written contract or agreement, or the limits shown in the Declarations, whichever are less.
- b. The insurance provided to such person or organization does not apply to:
  - (1) Any "bodily injury" or "property damage" that occurs, or any "personal and advertising injury" caused by an offense that is committed, after such contract or agreement is no longer in effect; or
  - (2) Any "bodily injury", "property damage" or "personal and advertising injury" arising out of any structural alterations, new construction or demolition operations performed by or on behalf of such mortgagee, assignee, successor or receiver.

**G. BLANKET ADDITIONAL INSURED – GOVERNMENTAL ENTITIES – PERMITS OR AUTHORIZATIONS RELATING TO PREMISES**

The following is added to **SECTION II – WHO IS AN INSURED**:

Any governmental entity that has issued a permit or authorization with respect to premises owned or occupied by, or rented or loaned to, you and that you are required by any ordinance, law, building code or written contract or agreement to include as an additional insured on this Coverage Part is an insured, but only with respect to liability for "bodily injury", "property damage" or "personal and advertising injury" arising out of the existence, ownership, use, maintenance, repair, construction, erection or removal of any of the following for which that governmental entity has

issued such permit or authorization: advertising signs, awnings, canopies, cellar entrances, coal holes, driveways, manholes, marquees, hoist away openings, sidewalk vaults, elevators, street banners or decorations.

**H. BLANKET ADDITIONAL INSURED – GOVERNMENTAL ENTITIES – PERMITS OR AUTHORIZATIONS RELATING TO OPERATIONS**

The following is added to **SECTION II – WHO IS AN INSURED**:

Any governmental entity that has issued a permit or authorization with respect to operations performed by you or on your behalf and that you are required by any ordinance, law, building code or written contract or agreement to include as an additional insured on this Coverage Part is an insured, but only with respect to liability for "bodily injury", "property damage" or "personal and advertising injury" arising out of such operations.

The insurance provided to such governmental entity does not apply to:

- a. Any "bodily injury", "property damage" or "personal and advertising injury" arising out of operations performed for the governmental entity; or
- b. Any "bodily injury" or "property damage" included in the "products-completed operations hazard".

**I. BLANKET ADDITIONAL INSURED – GRANTORS OF FRANCHISES**

The following is added to **SECTION II – WHO IS AN INSURED**:

Any person or organization that grants a franchise to you is an insured, but only with respect to liability for "bodily injury", "property damage" or "personal and advertising injury" arising out of your operations in the franchise granted by that person or organization.

If a written contract or agreement exists between you and such additional insured, the limits of insurance provided to such insured will be the minimum limits that you agreed to provide in the written contract or agreement, or the limits shown in the Declarations, whichever are less.

**J. INCIDENTAL MEDICAL MALPRACTICE**

1. The following replaces Paragraph **b.** of the definition of "occurrence" in the **DEFINITIONS** Section:

- b. An act or omission committed in providing or failing to provide "incidental medical

services", first aid or "Good Samaritan services" to a person, unless you are in the business or occupation of providing professional health care services.

2. The following replaces the last paragraph of Paragraph **2.a.(1)** of **SECTION II – WHO IS AN INSURED**:

Unless you are in the business or occupation of providing professional health care services, Paragraphs **(1)(a), (b), (c)** and **(d)** above do not apply to "bodily injury" arising out of providing or failing to provide:

**(a)** "Incidental medical services" by any of your "employees" who is a nurse, nurse assistant, emergency medical technician, paramedic, athletic trainer, audiologist, dietician, nutritionist, occupational therapist or occupational therapy assistant, physical therapist or speech-language pathologist; or

**(b)** First aid or "Good Samaritan services" by any of your "employees" or "volunteer workers", other than an employed or volunteer doctor. Any such "employees" or "volunteer workers" providing or failing to provide first aid or "Good Samaritan services" during their work hours for you will be deemed to be acting within the scope of their employment by you or performing duties related to the conduct of your business.

3. The following replaces the last sentence of Paragraph **5.** of **SECTION III – LIMITS OF INSURANCE**:

For the purposes of determining the applicable Each Occurrence Limit, all related acts or omissions committed in providing or failing to provide "incidental medical services", first aid or "Good Samaritan services" to any one person will be deemed to be one "occurrence".

4. The following exclusion is added to Paragraph **2., Exclusions,** of **SECTION I – COVERAGES – COVERAGE A – BODILY INJURY AND PROPERTY DAMAGE LIABILITY**:

**Sale Of Pharmaceuticals**

"Bodily injury" or "property damage" arising out of the violation of a penal statute or ordinance relating to the sale of pharmaceuticals committed by, or with the knowledge or consent of, the insured.

5. The following is added to the **DEFINITIONS** Section:

"Incidental medical services" means:

- a. Medical, surgical, dental, laboratory, x-ray or nursing service or treatment, advice or instruction, or the related furnishing of food or beverages; or
- b. The furnishing or dispensing of drugs or medical, dental, or surgical supplies or appliances.

6. The following is added to Paragraph 4.b., **Excess Insurance**, of **SECTION IV – COMMERCIAL GENERAL LIABILITY CONDITIONS**:

This insurance is excess over any valid and collectible other insurance, whether primary, excess, contingent or on any other basis, that is available to any of your "employees" for "bodily injury" that arises out of providing or failing to provide "incidental medical services" to any person to the extent not subject to Paragraph 2.a.(1) of Section II – Who Is An Insured.

**K. MEDICAL PAYMENTS – INCREASED LIMIT**

The following replaces Paragraph 7. of **SECTION III – LIMITS OF INSURANCE**:

7. Subject to Paragraph 5. above, the Medical Expense Limit is the most we will pay under Coverage C for all medical expenses because of "bodily injury" sustained by any one person, and will be the higher of:

- a. \$10,000; or
- b. The amount shown in the Declarations of this Coverage Part for Medical Expense Limit.

**L. BLANKET WAIVER OF SUBROGATION**

The following is added to Paragraph 8., **Transfer Of Rights Of Recovery Against Others To Us**, of **SECTION IV – COMMERCIAL GENERAL LIABILITY CONDITIONS**:

If the insured has agreed in a contract or agreement to waive that insured's right of recovery against any person or organization, we waive our right of recovery against such person or organization, but only for payments we make because of:

- a. "Bodily injury" or "property damage" that occurs; or
- b. "Personal and advertising injury" caused by an offense that is committed; subsequent to the execution of the contract or agreement.

**M. CONTRACTUAL LIABILITY – RAILROADS**

1. The following replaces Paragraph c. of the definition of "insured contract" in the **DEFINITIONS** Section:
  - c. Any easement or license agreement;
2. Paragraph f.(1) of the definition of "insured contract" in the **DEFINITIONS** Section is deleted.

**c. Method Of Sharing**

If all of the other insurance permits contribution by equal shares, we will follow this method also. Under this approach each insurer contributes equal amounts until it has paid its applicable limit of insurance or none of the loss remains, whichever comes first.

If any of the other insurance does not permit contribution by equal shares, we will contribute by limits. Under this method, each insurer's share is based on the ratio of its applicable limit of insurance to the total applicable limits of insurance of all insurers.

**d. Primary And Non-Contributory Insurance If Required By Written Contract**

If you specifically agree in a written contract or agreement that the insurance afforded to an insured under this Coverage Part must apply on a primary basis, or a primary and non-contributory basis, this insurance is primary to other insurance that is available to such insured which covers such insured as a named insured, and we will not share with that other insurance, provided that:

- (1) The "bodily injury" or "property damage" for which coverage is sought occurs; and
- (2) The "personal and advertising injury" for which coverage is sought is caused by an offense that is committed;

subsequent to the signing of that contract or agreement by you.

**5. Premium Audit**

- a. We will compute all premiums for this Coverage Part in accordance with our rules and rates.
- b. Premium shown in this Coverage Part as advance premium is a deposit premium only. At the close of each audit period we will compute the earned premium for that period and send notice to the first Named Insured. The due date for audit and retrospective premiums is the date shown as the due date on the bill. If the sum of the advance and audit premiums paid for the policy period is greater than the earned premium, we will return the excess to the first Named Insured.
- c. The first Named Insured must keep records of the information we need for premium computation, and send us copies at such times as we may request.

**6. Representations**

By accepting this policy, you agree:

- a. The statements in the Declarations are accurate and complete;
- b. Those statements are based upon representations you made to us; and
- c. We have issued this policy in reliance upon your representations.

The unintentional omission of, or unintentional error in, any information provided by you which we relied upon in issuing this policy will not prejudice your rights under this insurance. However, this provision does not affect our right to collect additional premium or to exercise our rights of cancellation or nonrenewal in accordance with applicable insurance laws or regulations.

**7. Separation Of Insureds**

Except with respect to the Limits of Insurance, and any rights or duties specifically assigned in this Coverage Part to the first Named Insured, this insurance applies:

- a. As if each Named Insured were the only Named Insured; and
- b. Separately to each insured against whom claim is made or "suit" is brought.

**8. Transfer Of Rights Of Recovery Against Others To Us**

If the insured has rights to recover all or part of any payment we have made under this Coverage Part, those rights are transferred to us. The insured must do nothing after loss to impair them. At our request, the insured will bring "suit" or transfer those rights to us and help us enforce them.

**9. When We Do Not Renew**

If we decide not to renew this Coverage Part, we will mail or deliver to the first Named Insured shown in the Declarations written notice of the nonrenewal not less than 30 days before the expiration date.

If notice is mailed, proof of mailing will be sufficient proof of notice.

**SECTION V – DEFINITIONS**

1. "Advertisement" means a notice that is broadcast or published to the general public or specific market segments about your goods, products or services for the purpose of attracting customers or supporters. For the purposes of this definition:
  - a. Notices that are published include material placed on the Internet or on similar electronic means of communication; and
  - b. Regarding websites, only that part of a website that is about your goods, products or services for the purposes of attracting customers or supporters is considered an advertisement.



**THIS ENDORSEMENT CHANGES THE POLICY. PLEASE READ IT CAREFULLY.**

## **BUSINESS AUTO EXTENSION ENDORSEMENT**

This endorsement modifies insurance provided under the following:

### **BUSINESS AUTO COVERAGE FORM**

**GENERAL DESCRIPTION OF COVERAGE** – This endorsement broadens coverage. However, coverage for any injury, damage or medical expenses described in any of the provisions of this endorsement may be excluded or limited by another endorsement to the Coverage Part, and these coverage broadening provisions do not apply to the extent that coverage is excluded or limited by such an endorsement. The following listing is a general coverage description only. Limitations and exclusions may apply to these coverages. Read all the provisions of this endorsement and the rest of your policy carefully to determine rights, duties, and what is and is not covered.

- A. BROAD FORM NAMED INSURED**
- B. BLANKET ADDITIONAL INSURED**
- C. EMPLOYEE HIRED AUTO**
- D. EMPLOYEES AS INSURED**
- E. SUPPLEMENTARY PAYMENTS – INCREASED LIMITS**
- F. HIRED AUTO – LIMITED WORLDWIDE COVERAGE – INDEMNITY BASIS**
- G. WAIVER OF DEDUCTIBLE – GLASS**
- H. HIRED AUTO PHYSICAL DAMAGE – LOSS OF USE – INCREASED LIMIT**
- I. PHYSICAL DAMAGE – TRANSPORTATION EXPENSES – INCREASED LIMIT**
- J. PERSONAL PROPERTY**
- K. AIRBAGS**
- L. NOTICE AND KNOWLEDGE OF ACCIDENT OR LOSS**
- M. BLANKET WAIVER OF SUBROGATION**
- N. UNINTENTIONAL ERRORS OR OMISSIONS**

### **PROVISIONS**

#### **A. BROAD FORM NAMED INSURED**

The following is added to Paragraph **A.1.**, **Who Is An Insured**, of **SECTION II – COVERED AUTOS LIABILITY COVERAGE**:

Any organization you newly acquire or form during the policy period over which you maintain 50% or more ownership interest and that is not separately insured for Business Auto Coverage. Coverage under this provision is afforded only until the 180th day after you acquire or form the organization or the end of the policy period, whichever is earlier.

#### **B. BLANKET ADDITIONAL INSURED**

The following is added to Paragraph **c.** in **A.1.**, **Who Is An Insured**, of **SECTION II – COVERED AUTOS LIABILITY COVERAGE**:

Any person or organization who is required under a written contract or agreement between you and that person or organization, that is signed and executed by you before the "bodily injury" or "property damage" occurs and that is in effect during the policy period, to be named as an additional insured is an "insured" for Covered Autos Liability Coverage, but only for damages to which

this insurance applies and only to the extent that person or organization qualifies as an "insured" under the Who Is An Insured provision contained in Section II.

#### **C. EMPLOYEE HIRED AUTO**

**1.** The following is added to Paragraph **A.1.**, **Who Is An Insured**, of **SECTION II – COVERED AUTOS LIABILITY COVERAGE**:

An "employee" of yours is an "insured" while operating an "auto" hired or rented under a contract or agreement in an "employees" name, with your permission, while performing duties related to the conduct of your business.

**2.** The following replaces Paragraph **b.** in **B.5.**, **Other Insurance**, of **SECTION IV – BUSINESS AUTO CONDITIONS**:

**b.** For Hired Auto Physical Damage Coverage, the following are deemed to be covered "autos" you own:

- (1)** Any covered "auto" you lease, hire, rent or borrow; and
- (2)** Any covered "auto" hired or rented by your "employee" under a contract in an "employee s" name, with your

permission, while performing duties related to the conduct of your business.

However, any "auto" that is leased, hired, rented or borrowed with a driver is not a covered "auto".

#### D. EMPLOYEES AS INSURED

The following is added to Paragraph A.1., **Who Is An Insured**, of SECTION II – COVERED AUTOS LIABILITY COVERAGE:

Any "employee" of yours is an "insured" while using a covered "auto" you don't own, hire or borrow in your business or your personal affairs.

#### E. SUPPLEMENTARY PAYMENTS – INCREASED LIMITS

1. The following replaces Paragraph A.2.a.(2), of SECTION II – COVERED AUTOS LIABILITY COVERAGE:

(2) Up to \$3,000 for cost of bail bonds (including bonds for related traffic law violations) required because of an "accident" we cover. We do not have to furnish these bonds.

2. The following replaces Paragraph A.2.a.(4), of SECTION II – COVERED AUTOS LIABILITY COVERAGE:

(4) All reasonable expenses incurred by the "insured" at our request, including actual loss of earnings up to \$500 a day because of time off from work.

#### F. HIRED AUTO – LIMITED WORLDWIDE COVERAGE – INDEMNITY BASIS

The following replaces Subparagraph (5) in Paragraph B.7., **Policy Period, Coverage Territory**, of SECTION IV – BUSINESS AUTO CONDITIONS:

(5) Anywhere in the world, except any country or jurisdiction while any trade sanction, embargo, or similar regulation imposed by the United States of America applies to and prohibits the transaction of business with or within such country or jurisdiction, for Covered Autos Liability Coverage for any covered "auto" that you lease, hire, rent or borrow without a driver for a period of 30 days or less and that is not an "auto" you lease, hire, rent or borrow from any of your "employees", partners (if you are a partnership), members (if you are a limited liability company) or members of their households.

(a) With respect to any claim made or "suit" brought outside the United States of America, the territories and possessions of the United States of America, Puerto Rico and Canada:

(i) You must arrange to defend the "insured" against, and investigate or settle any such claim or "suit" and keep us advised of all proceedings and actions.

(ii) Neither you nor any other involved "insured" will make any settlement without our consent.

(iii) We may, at our discretion, participate in defending the "insured" against, or in the settlement of, any claim or "suit".

(iv) We will reimburse the "insured" for sums that the "insured" legally must pay as damages because of "bodily injury" or "property damage" to which this insurance applies, that the "insured" pays with our consent, but only up to the limit described in Paragraph C., Limits Of Insurance, of SECTION II – COVERED AUTOS LIABILITY COVERAGE.

(v) We will reimburse the "insured" for the reasonable expenses incurred with our consent for your investigation of such claims and your defense of the "insured" against any such "suit", but only up to and included within the limit described in Paragraph C., Limits Of Insurance, of SECTION II – COVERED AUTOS LIABILITY COVERAGE, and not in addition to such limit. Our duty to make such payments ends when we have used up the applicable limit of insurance in payments for damages, settlements or defense expenses.

(b) This insurance is excess over any valid and collectible other insurance available to the "insured" whether primary, excess, contingent or on any other basis.

(c) This insurance is not a substitute for required or compulsory insurance in any country outside the United States, its territories and possessions, Puerto Rico and Canada.

You agree to maintain all required or compulsory insurance in any such country up to the minimum limits required by local law. Your failure to comply with compulsory insurance requirements will not invalidate the coverage afforded by this policy, but we will only be liable to the same extent we would have been liable had you complied with the compulsory insurance requirements.

- (d) It is understood that we are not an admitted or authorized insurer outside the United States of America, its territories and possessions, Puerto Rico and Canada. We assume no responsibility for the furnishing of certificates of insurance, or for compliance in any way with the laws of other countries relating to insurance.

#### G. WAIVER OF DEDUCTIBLE – GLASS

The following is added to Paragraph D., **Deductible**, of **SECTION III – PHYSICAL DAMAGE COVERAGE**:

No deductible for a covered "auto" will apply to glass damage if the glass is repaired rather than replaced.

#### H. HIRED AUTO PHYSICAL DAMAGE – LOSS OF USE – INCREASED LIMIT

The following replaces the last sentence of Paragraph A.4.b., **Loss Of Use Expenses**, of **SECTION III – PHYSICAL DAMAGE COVERAGE**:

However, the most we will pay for any expenses for loss of use is \$65 per day, to a maximum of \$750 for any one "accident".

#### I. PHYSICAL DAMAGE – TRANSPORTATION EXPENSES – INCREASED LIMIT

The following replaces the first sentence in Paragraph A.4.a., **Transportation Expenses**, of **SECTION III – PHYSICAL DAMAGE COVERAGE**:

We will pay up to \$50 per day to a maximum of \$1,500 for temporary transportation expense incurred by you because of the total theft of a covered "auto" of the private passenger type.

#### J. PERSONAL PROPERTY

The following is added to Paragraph A.4., **Coverage Extensions**, of **SECTION III – PHYSICAL DAMAGE COVERAGE**:

##### Personal Property

We will pay up to \$400 for "loss" to wearing apparel and other personal property which is:

- (1) Owned by an "insured"; and

- (2) In or on your covered "auto".

This coverage applies only in the event of a total theft of your covered "auto".

No deductibles apply to this Personal Property coverage.

#### K. AIRBAGS

The following is added to Paragraph B.3., **Exclusions**, of **SECTION III – PHYSICAL DAMAGE COVERAGE**:

Exclusion 3.a. does not apply to "loss" to one or more airbags in a covered "auto" you own that inflate due to a cause other than a cause of "loss" set forth in Paragraphs A.1.b. and A.1.c., but only:

- If that "auto" is a covered "auto" for Comprehensive Coverage under this policy;
- The airbags are not covered under any warranty; and
- The airbags were not intentionally inflated.

We will pay up to a maximum of \$1,000 for any one "loss".

#### L. NOTICE AND KNOWLEDGE OF ACCIDENT OR LOSS

The following is added to Paragraph A.2.a., of **SECTION IV – BUSINESS AUTO CONDITIONS**:

Your duty to give us or our authorized representative prompt notice of the "accident" or "loss" applies only when the "accident" or "loss" is known to:

- You (if you are an individual);
- A partner (if you are a partnership);
- A member (if you are a limited liability company);
- An executive officer, director or insurance manager (if you are a corporation or other organization); or
- Any "employee" authorized by you to give notice of the "accident" or "loss".

#### M. BLANKET WAIVER OF SUBROGATION

The following replaces Paragraph A.5., **Transfer Of Rights Of Recovery Against Others To Us**, of **SECTION IV – BUSINESS AUTO CONDITIONS**:

##### 5. Transfer Of Rights Of Recovery Against Others To Us

We waive any right of recovery we may have against any person or organization to the extent required of you by a written contract signed and executed prior to any "accident" or "loss", provided that the "accident" or "loss" arises out of operations contemplated by



such contract. The waiver applies only to the person or organization designated in such contract.

**N. UNINTENTIONAL ERRORS OR OMISSIONS**

The following is added to Paragraph **B.2., Concealment, Misrepresentation, Or Fraud,** of **SECTION IV – BUSINESS AUTO CONDITIONS:**

The unintentional omission of, or unintentional error in, any information given by you shall not prejudice your rights under this insurance. However this provision does not affect our right to collect additional premium or exercise our right of cancellation or non-renewal.

**THIS ENDORSEMENT CHANGES THE POLICY. PLEASE READ IT CAREFULLY.**

## **BLANKET ADDITIONAL INSURED – PRIMARY AND NON-CONTRIBUTORY WITH OTHER INSURANCE**

This endorsement modifies insurance provided under the following:

BUSINESS AUTO COVERAGE FORM

### **PROVISIONS**

1. The following is added to Paragraph **A.1.c., Who Is An Insured**, of **SECTION II – COVERED AUTOS LIABILITY COVERAGE**:

This includes any person or organization who you are required under a written contract or agreement between you and that person or organization, that is signed by you before the "bodily injury" or "property damage" occurs and that is in effect during the policy period, to name as an additional insured for Covered Autos Liability Coverage, but only for damages to which this insurance applies and only to the extent of that person's or organization's liability for the conduct of another "insured".

2. The following is added to Paragraph **B.5., Other Insurance** of **SECTION IV – BUSINESS AUTO CONDITIONS**:

Regardless of the provisions of paragraph a. and paragraph **d.** of this part **5. Other Insurance**, this insurance is primary to and non-contributory with applicable other insurance under which an additional insured person or organization is the first named insured when the written contract or agreement between you and that person or organization, that is signed by you before the "bodily injury" or "property damage" occurs and that is in effect during the policy period, requires this insurance to be primary and non-contributory.

## EXCESS FOLLOW-FORM AND UMBRELLA LIABILITY INSURANCE

**THIS POLICY, IN PART, PROVIDES FOLLOW-FORM LIABILITY COVERAGE. COVERAGE WILL APPLY ON A CLAIMS-MADE BASIS WHEN FOLLOWING CLAIMS-MADE UNDERLYING INSURANCE.**

**COVERAGE WILL APPLY ON A DEFENSE-WITHIN-LIMITS BASIS WHEN FOLLOWING UNDERLYING INSURANCE UNDER WHICH DEFENSE EXPENSES ARE PAYABLE WITHIN, AND NOT IN ADDITION TO, THE LIMITS OF INSURANCE. WHEN FOLLOWING SUCH UNDERLYING INSURANCE, PAYMENT OF DEFENSE EXPENSES UNDER THIS POLICY WILL REDUCE, AND MAY EXHAUST, THE LIMITS OF INSURANCE OF THIS POLICY.**

**PLEASE READ THE ENTIRE POLICY CAREFULLY.**

Various provisions in this policy restrict coverage. Read the entire policy carefully to determine rights, duties and what is and is not covered.

Throughout this policy, the words "you" and "your" refer to the Named Insured shown in the Declarations and any other person or organization qualifying as a Named Insured under this policy. The words "we", "us" and "our" refer to the company providing this insurance.

The word "insured" means any person or organization qualifying as such under **SECTION II – WHO IS AN INSURED**.

Other words and phrases that appear in quotation marks have special meaning. Refer to **SECTION VI – DEFINITIONS**.

### SECTION I – COVERAGES

#### A. COVERAGE A – EXCESS FOLLOW-FORM LIABILITY

1. We will pay on behalf of the insured those sums, in excess of the "applicable underlying limit", that the insured becomes legally obligated to pay as damages to which Coverage **A** of this insurance applies, provided that the "underlying insurance" would apply to such damages but for the exhaustion of its applicable limits of insurance. If a sublimit is specified in any "underlying insurance", Coverage **A** of this insurance applies to damages that are in excess of that sublimit only if such sublimit is shown for that "underlying insurance" in the Schedule Of Underlying Insurance.
2. Coverage **A** of this insurance is subject to the same terms, conditions, agreements, exclusions and definitions as the "underlying insurance", except with respect to any

provisions to the contrary contained in this insurance.

3. The amount we will pay for damages is limited as described in **SECTION III – LIMITS OF INSURANCE**.
4. For the purposes of Paragraph 1. above:
  - a. The applicable limit of insurance stated for the policies of "underlying insurance" in the Schedule Of Underlying Insurance will be considered to be reduced or exhausted only by the following payments:
    - (1) Payments of judgments or settlements for damages that are covered by that "underlying insurance". However, if such "underlying insurance" has a policy period which differs from the policy period of this Excess Follow-Form And Umbrella Liability Insurance, any such payments for damages that would not be covered by this Excess

Follow-Form And Umbrella Liability Insurance because of its different policy period will not reduce or exhaust the applicable limit of insurance stated for such "underlying insurance";

- (2) Payments of "medical expenses" that are covered by that "underlying insurance" and are incurred for "bodily injury" caused by an accident that takes place during the policy period of this Excess Follow-Form And Umbrella Liability Insurance; or
- (3) Payments of defense expenses that are covered by that "underlying insurance", only if such "underlying insurance" includes such payments within the limits of insurance. However, if such "underlying insurance" has a policy period which differs from the policy period of this Excess Follow-Form And Umbrella Liability Insurance, any such payments for defense expenses that would not be covered by this Excess Follow-Form And Umbrella Liability Insurance because of its different policy period will not reduce or exhaust the applicable limit of insurance stated for such "underlying insurance".

If the applicable limit of insurance stated for the policies of "underlying insurance" in the Schedule Of Underlying Insurance is actually reduced or exhausted by other payments, Coverage **A** of this insurance is not invalidated. However, in the event of a loss, we will pay only to the extent that we would have paid had such limit not been actually reduced or exhausted by such other payments.

- b. If any "underlying insurance" has a limit of insurance greater than the amount shown for that insurance in the Schedule of Underlying Insurance, this insurance will apply in excess of that greater amount. If any "underlying insurance" has a limit of insurance, prior to any reduction or exhaustion by payment of damages, "medical expenses" or defense expenses described in Paragraph **a.** above, that is less than the amount shown for that insurance in the Schedule Of Underlying Insurance, this insurance will apply in excess of the amount shown for such insurance in the Schedule Of Underlying Insurance.

- 5. When the "underlying insurance" applies on a claims-made basis and includes a retroactive date provision, the retroactive date for Coverage **A** of this insurance is the same as the retroactive date of that "underlying insurance".

**B. COVERAGE B – UMBRELLA LIABILITY**

- 1. We will pay on behalf of the insured those sums in excess of the "self-insured retention" that the insured becomes legally obligated to pay as damages because of "bodily injury", "property damage", "personal injury" or "advertising injury" to which Coverage **B** of this insurance applies.
- 2. Coverage **B** of this insurance applies to "bodily injury" or "property damage" only if:
  - a. The "bodily injury" or "property damage" is caused by an "occurrence" that takes place anywhere in the world;
  - b. The "bodily injury" or "property damage" occurs during the policy period; and
  - c. Prior to the policy period, no insured listed under Paragraph **1.** in Paragraph **B., COVERAGE B – UMBRELLA LIABILITY, of SECTION II – WHO IS AN INSURED** and no "employee" authorized by you to give or receive notice of an "occurrence" or claim, knew that the "bodily injury" or "property damage" had occurred, in whole or in part. If such a listed insured or authorized "employee" knew, prior to the policy period, that the "bodily injury" or "property damage" occurred, in whole or in part, then any continuation, change or resumption of such "bodily injury" or "property damage" during or after the policy period will be deemed to have been known prior to the policy period.
- 3. Coverage **B** of this insurance applies to "personal injury" or "advertising injury" caused by an offense arising out of your business, but only if the offense was committed during the policy period anywhere in the world.
- 4. The amount we will pay for damages is limited as described in **SECTION III – LIMITS OF INSURANCE.**
- 5. "Bodily injury" or "property damage":
  - a. Which occurs during the policy period; and
  - b. Which was not prior to, but was during, the policy period known to have occurred by any insured listed under Paragraph **1.** in Paragraph **B., COVERAGE B –**

**UMBRELLA LIABILITY** of **SECTION II – WHO IS AN INSURED**, or any "employee" authorized by you to give notice of an "occurrence" or claim;

includes any continuation, change or resumption of the "bodily injury" or "property damage" after the end of the policy period.

6. "Bodily injury" or "property damage" will be deemed to have been known to have occurred at the earliest time when any insured listed under Paragraph 1. in Paragraph B., **COVERAGE B – UMBRELLA LIABILITY**, of **SECTION II – WHO IS AN INSURED** or any "employee" authorized by you to give or receive notice of an "occurrence" or claim:
  - a. Reports all, or any part, of the "bodily injury" or "property damage" to us or any other insurer;
  - b. Receives a written or verbal demand or claim for damages because of the "bodily injury" or "property damage"; or
  - c. Becomes aware by any other means that the "bodily injury" or "property damage" has occurred or has begun to occur.
7. Damages because of "bodily injury" include damages claimed by any person or organization for care, loss of services or death resulting at any time from the "bodily injury".
8. Coverage B of this insurance does not apply to damages covered by any "underlying insurance" or that would have been covered by any "underlying insurance" but for the exhaustion of its applicable limit of insurance.

**C. COVERAGE C – CRISIS MANAGEMENT SERVICE EXPENSES**

1. We will reimburse the insured, or pay on the insured's behalf, "crisis management service expenses" to which Coverage C applies.
2. Coverage C of this insurance applies to "crisis management service expenses" that:
  - a. Arise out of a "crisis management event" that first commences during the policy period;
  - b. Are incurred by the insured, after a "crisis management event" first commences and before such event ends; and
  - c. Are submitted to us within 180 days after the "crisis management advisor" advises you that the "crisis management event" no longer exists.
3. A "crisis management event" will be deemed to:

- a. First commence at the time when any "executive officer" first becomes aware of an "event" or "occurrence" that leads to that "crisis management event"; and

- b. End when we decide that the crisis no longer exists or when the Crisis Management Service Expenses Limit has been exhausted, whichever occurs first.

4. The amount we will pay for "crisis management service expenses" is limited as described in **SECTION III – LIMITS OF INSURANCE**.

5. A "self-insured retention" does not apply to "crisis management service expenses".

6. Any payment of "crisis management service expenses" that we make will not be determinative of our obligations under this insurance with respect to any claim or "suit" or create any duty to defend or indemnify any insured for any claim or "suit".

**D. DEFENSE AND SUPPLEMENTARY PAYMENTS**

1. We will have the right and duty to defend the insured:

- a. Under Coverage A, against a "suit" seeking damages to which such coverage applies, if:

- (1) The "applicable underlying limit" is the applicable limit of insurance stated for a policy of "underlying insurance" in the Schedule Of Underlying Insurance and such limit has been exhausted solely due to payments as permitted in Paragraphs 4.a.(1), (2) and (3) of **COVERAGE A – EXCESS FOLLOW-FORM LIABILITY** of **SECTION I – COVERAGES**; or

- (2) The "applicable underlying limit" is the applicable limit of any "other insurance" and such limit has been exhausted by payments of judgments, settlements or medical expenses, or related costs or expenses (if such costs or expenses reduce such limits).

For any "suit" for which we have the right and duty to defend the insured under Coverage A, defense expenses will be within the limits of insurance of this policy when such expenses are within the limits of insurance of the applicable "underlying insurance"; or

- b. Under Coverage B, against a "suit" seeking damages to which such coverage applies.

2. We have no duty to defend any insured against any "suit":
  - a. Seeking damages to which this insurance does not apply; or
  - b. If any other insurer has a duty to defend.
3. When we have the duty to defend, we may, at our discretion, investigate and settle any claim or "suit". In all other cases, we may, at our discretion, participate in the investigation, defense and settlement of any claim or "suit" for damages to which this insurance may apply. If we exercise such right to participate, all expenses we incur in doing so will not reduce the applicable limits of insurance.
4. Our duty to defend ends when we have used up the applicable limit of insurance in the payment of judgments or settlements, or defense expenses if such expenses are within the limits of insurance of this policy.
5. We will pay, with respect to a claim we investigate or settle, or "suit" against an insured we defend:
  - a. All expenses we incur.
  - b. The cost of:
    - (1) Bail bonds required because of accidents or traffic law violations arising out of the use of any vehicle to which this insurance applies; or
    - (2) Appeal bonds and bonds to release attachments;
 

but only for bond amounts within the applicable limit of insurance. We do not have to furnish these bonds.
  - c. All reasonable expenses incurred by the insured at our request to assist us in the investigation or defense of such claim or "suit", including actual loss of earnings up to \$1,000 a day because of time off from work.
  - d. All court costs taxed against the insured in the "suit". However, these payments do not include attorneys' fees or attorneys' expenses taxed against the insured.
  - e. Prejudgment interest awarded against the insured on that part of the judgment we pay. If we make an offer to pay the applicable limit of insurance, we will not pay any prejudgment interest based on that period of time after the offer.
  - f. All interest that accrues on the full amount of any judgment after entry of the judgment and before we have paid, offered to pay or deposited in court the part of the judgment that is within the

applicable limit of insurance. If we do not pay part of the judgment for any reason other than it is more than the applicable limit of insurance, we will not pay any interest that accrues on that portion of the judgment.

With respect to a claim we investigate or settle, or "suit" against an insured we defend under **COVERAGE A – EXCESS FOLLOW-FORM LIABILITY**, these payments will not reduce the applicable limits of insurance, but only if the applicable "underlying insurance" provides for such payments in addition to its limits of insurance. With respect to a claim we investigate or settle, or "suit" against an insured we defend under **COVERAGE B – UMBRELLA LIABILITY**, these payments will not reduce the applicable limits of insurance.

## SECTION II – WHO IS AN INSURED

### A. COVERAGE A – EXCESS FOLLOW-FORM LIABILITY

With respect to Coverage A, the following persons and organizations qualify as insureds:

1. The Named Insured shown in the Declarations; and
2. Any other person or organization qualifying as an insured in the "underlying insurance". If you have agreed to provide insurance for that person or organization in a written contract or agreement:
  - a. The limits of insurance afforded to such person or organization will be:
    - (1) The amount by which the minimum limits of insurance you agreed to provide such person or organization in that written contract or agreement exceed the total limits of insurance of all applicable "underlying insurance"; or
    - (2) The limits of insurance of this policy; whichever is less; and
  - b. Coverage under this policy does not apply to such person or organization if the minimum limits of insurance you agreed to provide such person or organization in that written contract or agreement are wholly within the total limits of insurance of all available applicable "underlying insurance".

### B. COVERAGE B – UMBRELLA LIABILITY

With respect to Coverage B:

1. The Named Insured shown in the Declarations is an insured.
2. If you are:

- a. An individual, your spouse is also an insured, but only with respect to the conduct of a business of which you are the sole owner.
  - b. A partnership or joint venture, your members, your partners and their spouses are also insureds, but only with respect to the conduct of your business.
  - c. A limited liability company, your members are also insureds, but only with respect to the conduct of your business. Your managers are also insureds, but only with respect to their duties as your managers.
  - d. An organization other than a partnership, joint venture or limited liability company, your "officers" and directors are also insureds, but only with respect to their duties as your "officers" or directors. Your stockholders are also insureds, but only with respect to their liability as stockholders.
  - e. A trust, your trustees are also insureds, but only with respect to their duties as trustees.
3. Each of the following is also an insured:
- a. Your "volunteer workers" only while performing duties related to the conduct of your business, or your "employees", other than either your "officers" (if you are an organization other than a partnership, joint venture or limited liability company) or your managers (if you are a limited liability company), but only for acts within the scope of their employment by you or while performing duties related to the conduct of your business. However, none of these "employees" or "volunteer workers" are insureds for:
    - (1) "Bodily injury" or "personal injury":
      - (a) To you, to your partners or members (if you are a partnership or joint venture), to your members (if you are a limited liability company), to a co-"employee" while in the course of his or her employment or performing duties related to the conduct of your business, or to your other "volunteer workers" while performing duties related to the conduct of your business;
      - (b) To the spouse, child, parent, brother or sister of that co-"employee" or "volunteer worker" as a consequence of Paragraph (1)(a) above;
    - (c) For which there is any obligation to share damages with or repay someone else who must pay damages because of the injury described in Paragraph (1)(a) or (b) above; or
    - (d) Arising out of his or her providing or failing to provide professional health care services.
- Unless you are in the business or occupation of providing professional health care services, Paragraphs (1)(a), (b), (c) and (d) above do not apply to "bodily injury" arising out of providing or failing to provide first aid or "Good Samaritan services" by any of your "employees" or "volunteer workers" other than an employed or volunteer doctor. Any such "employees" or "volunteer workers" providing or failing to provide first aid or "Good Samaritan services" during their work hours for you will be deemed to be acting within the scope of their employment by you or performing duties related to the conduct of your business.
- (2) "Property damage" to property:
    - (a) Owned, occupied or used by; or
    - (b) Rented to, in the care, custody or control of, or over which physical control is being exercised for any purpose by;
      - you, any of your "employees" or "volunteer workers", any of your partners or members (if you are a partnership or joint venture), or any of your members (if you are a limited liability company).
  - b. Any person (other than your "employee" or "volunteer worker"), or any organization, while acting as your real estate manager.
  - c. Any person or organization having proper temporary custody of your property if you die, but only:
    - (1) With respect to liability arising out of the maintenance or use of that property; and
    - (2) Until your legal representative has been appointed.
  - d. Your legal representative if you die, but only with respect to duties as such. That

representative will have all your rights and duties under this insurance.

4. Any organization, other than a partnership, joint venture or limited liability company, of which you are the sole owner, or in which you maintain an ownership interest of more than 50%, on the first day of the policy period is an insured and will qualify as a Named Insured. No such organization is an insured or will qualify as a Named Insured for "bodily injury" or "property damage" that occurred, or "personal injury" or "advertising injury" caused by an offense committed after the date, if any, during the policy period, that you no longer maintain an ownership interest of more than 50% in such organization.
5. Any organization you newly acquire or form, other than a partnership, joint venture or limited liability company, and of which you are the sole owner, or in which you maintain an ownership interest of more than 50%, is an insured and will qualify as a Named Insured if there is no other similar insurance available to that organization. However:
  - a. Coverage under this provision is afforded only until the 180<sup>th</sup> day after you acquire or form the organization or the end of the policy period, whichever is earlier; and
  - b. Coverage for such organization does not apply to:
    - (1) "Bodily injury" or "property damage" that occurred; or
    - (2) "Personal injury" or "advertising injury" arising out of an offense committed;
 before you acquired or formed the organization.

No person or organization is an insured or will qualify as a Named Insured with respect to the conduct of any current or past partnership, joint venture or limited liability company that is not shown as a Named Insured in the Declarations. This paragraph does not apply to any such partnership, joint venture or limited liability company that otherwise qualifies as an insured under Paragraph B. of SECTION II – WHO IS AN INSURED.

**C. COVERAGE C – CRISIS MANAGEMENT SERVICE EXPENSES**

With respect to Coverage C, the following persons and organizations are insureds and will qualify as Named Insureds:

1. The Named Insured shown in the Declarations.

2. Any organization, other than a partnership, joint venture or limited liability company, of which you are the sole owner, or in which you maintain an ownership interest of more than 50%, on the first day of the policy period. No such organization is an insured or will qualify as a Named Insured for "crisis management service expenses" arising out of a "crisis management event" that first commences after the date, if any, during the policy period, that you no longer maintain an ownership interest of more than 50% in such organization.
3. Any organization you newly acquire or form, other than a partnership, joint venture or limited liability company, and of which you are the sole owner, or in which you maintain an ownership interest of more than 50%, if there is no other similar insurance available to that organization. However:
  - a. Coverage under this provision is afforded only until the 180<sup>th</sup> day after you acquire or form the organization or the end of the policy period, whichever is earlier; and
  - b. Coverage for such organization does not apply to "crisis management service expenses" arising out of a "crisis management event" that occurred before you acquired or formed the organization, even if an "executive officer" only first becomes aware of an "event" or "occurrence" that leads to such "crisis management event" after the date you acquired or formed the organization.

No person or organization is an insured or will qualify as a Named Insured with respect to the conduct of any current or past partnership, joint venture or limited liability company that is not shown as a Named Insured in the Declarations.

**SECTION III – LIMITS OF INSURANCE**

- A. The Limits of Insurance shown in the Declarations and the rules below fix the most we will pay for the amounts described below to which this insurance applies regardless of the number of:
  1. Insureds;
  2. Claims made or "suits" brought;
  3. Number of vehicles involved;
  4. Persons or organizations making claims or bringing "suits"; or
  5. Coverages provided under this insurance.

As indicated in Paragraph D.1. of SECTION I – COVERAGES, for any "suit" for which we have the right and duty to defend the insured under Coverage A, defense expenses will be within the



limits of insurance of this policy when such expenses are within the limits of insurance of the applicable "underlying insurance".

**B.** The General Aggregate Limit is the most we will pay for the sum of all:

1. Damages; and
2. Defense expenses if such expenses are within the limits of insurance of this policy;

except:

1. Damages and defense expenses because of "bodily injury" or "property damage" included in the "auto hazard";
2. Damages and defense expenses because of "bodily injury" or "property damage" included in the "products-completed operations hazard"; or
3. Damages and defense expenses for which insurance is provided under any Aircraft Liability coverage included as "underlying insurance" to which no aggregate limit applies.

**C.** The Products-Completed Operations Aggregate Limit is the most we will pay for the sum of all:

1. Damages; and
2. Defense expenses if such expenses are within the limits of insurance of this policy; because of "bodily injury" or "property damage" included in the "products-completed operations hazard".

**D.** Subject to Paragraph **B.** or **C.** above, whichever applies, the Occurrence Limit is the most we will pay for the sum of all:

1. Damages, and defense expenses if such expenses are within the limits of insurance of this policy, under Coverage **A** arising out of any one "event" to which the "underlying insurance" applies a limit of insurance that is separate from any aggregate limit of insurance; and
2. Damages under Coverage **B** because of all "bodily injury", "property damage", "personal injury" or "advertising injury" arising out of any one "occurrence".

For the purposes of determining the applicable Occurrence Limit, all related acts or omissions committed in the providing or failing to provide first aid or "Good Samaritan services" to any one person will be considered one "occurrence".

**E.** The Crisis Management Service Expenses Limit is the most we will pay for the sum of all "crisis management service expenses" arising out of all "crisis management events". Payment of such "crisis management service expenses" is in addition to, and will not reduce, any other limit of insurance of this policy.

**F.** The limits of insurance of this policy apply separately to each consecutive annual period and to any remaining period of less than 12 months, starting with the beginning of the policy period shown in the Declarations. If the policy period is extended after issuance for an additional period of less than 12 months, the additional period will be deemed part of the last preceding period for purposes of determining the limits of insurance.

#### SECTION IV – EXCLUSIONS

This insurance does not apply to:

**A.** With respect to Coverage **A** and Coverage **B**:

##### 1. Asbestos

- a. Damages arising out of the actual or alleged presence or actual, alleged or threatened dispersal of asbestos, asbestos fibers or products containing asbestos, provided that the damages are caused or contributed to by the hazardous properties of asbestos.
- b. Damages arising out of the actual or alleged presence or actual, alleged or threatened dispersal of any solid, liquid, gaseous or thermal irritant or contaminant, including smoke, vapors, soot, fumes, acids, alkalis, chemicals and waste, and that are part of any claim or "suit" which also alleges any damages described in Paragraph **a.** above.
- c. Any loss, cost or expense arising out of any:
  - (1) Request, demand, order or statutory or regulatory requirement that any insured or others test for, monitor, clean up, remove, contain, treat, detoxify or neutralize, or in any way respond to, or assess the effects of, asbestos, asbestos fibers or products containing asbestos; or
  - (2) Claim or "suit" by or on behalf of any governmental authority or any other person or organization because of testing for, monitoring, cleaning up, removing, containing, treating, detoxifying or neutralizing, or in any way responding to, or assessing the effects of, asbestos, asbestos fibers or products containing asbestos.

##### 2. Employment-Related Practices

Damages because of injury to:

- a. A person arising out of any:
  - (1) Refusal to employ that person;
  - (2) Termination of that person's employment; or

- (3)** Employment-related practice, policy, act or omission, such as coercion, demotion, evaluation, reassignment, discipline, failure to promote or advance, harassment, humiliation, discrimination, libel, slander, violation of the person's right of privacy, malicious prosecution or false arrest, detention or imprisonment, applied to or directed at that person, regardless of whether such practice, policy, act or omission occurs, is applied or is committed before, during or after the time of that person's employment; or
- b.** The spouse, child, parent, brother or sister of that person as a consequence of injury to that person as described in Paragraphs **a.(1)**, **(2)** or **(3)** above.

This exclusion applies:

- a.** Whether the insured may be liable as an employer or in any other capacity; and
- b.** To any obligation to share damages with or repay someone else who must pay damages because of the injury.

### **3. ERISA, COBRA And Similar Laws**

Any obligation of the insured under:

- a.** The Employees Retirement Income Security Act Of 1974 (ERISA) or any of its amendments;
- b.** The Consolidated Omnibus Budget Reconciliation Act of 1985 (COBRA) or any of its amendments; or
- c.** Any similar common or statutory law of any jurisdiction.

### **4. Medical Expenses Or Payments**

Any obligation of the insured under any "medical expenses" or medical payments coverage.

### **5. Nuclear Material**

Damages arising out of:

- a.** The actual, alleged or threatened exposure of any person or property to; or
- b.** The "hazardous properties" of; any "nuclear material".

As used in this exclusion:

- a.** "Hazardous properties" includes radioactive, toxic or explosive properties;
- b.** "Nuclear material" means "source material", "special nuclear material" or "by-product material"; and
- c.** "Source material", "special nuclear material" and "by-product material" have

the meanings given them in the Atomic Energy Act of 1954 or any of its amendments.

### **6. Uninsured or Underinsured Motorists, No-Fault And Similar Laws**

Any liability imposed on the insured, or the insured's insurer, under any of the following laws:

- a.** Uninsured motorists;
- b.** Underinsured motorists;
- c.** Auto no-fault or other first-party personal injury protection (PIP);
- d.** Supplementary uninsured/underinsured motorists (New York); or
- e.** Medical expense benefits and income loss benefits (Virginia).

### **7. War**

Damages arising out of:

- a.** War, including undeclared or civil war; or
- b.** Warlike action by a military force, including action in hindering or defending against an actual or expected attack, by any government, sovereign or other authority using military personnel or other agents; or
- c.** Insurrection, rebellion, revolution, usurped power or action taken by governmental authority in hindering or defending against any of these.

### **8. Workers Compensation And Similar Laws**

Any obligation of the insured under a workers compensation, disability benefits or unemployment compensation law or any similar law.

## **B. With respect to Coverage B:**

### **1. Expected Or Intended Bodily Injury Or Property Damage**

"Bodily injury" or "property damage" expected or intended from the standpoint of the insured. This exclusion does not apply to "bodily injury" or "property damage" resulting from the use of reasonable force to protect persons or property.

### **2. Contractual Liability**

"Bodily injury", "property damage", "personal injury" or "advertising injury" for which the insured is obligated to pay damages by reason of the assumption of liability in a contract or agreement. This exclusion does not apply to liability for damages that the insured would have in the absence of the contract or agreement.

**3. Liquor Liability**

"Bodily injury" or "property damage" for which any insured may be liable by reason of:

- a. Causing or contributing to the intoxication of any person, including causing or contributing to the intoxication of any person because alcoholic beverages were permitted to be brought on your premises for consumption on your premises;
- b. The furnishing of alcoholic beverages to a person under the legal drinking age or under the influence of alcohol; or
- c. Any statute, ordinance or regulation relating to the sale, gift, distribution or use of alcoholic beverages.

**4. Employers Liability**

"Bodily injury" to:

- a. An "employee" of the insured arising out of and in the course of:
  - (1) Employment by the insured; or
  - (2) Performing duties related to the conduct of the insured's business; or
- b. The spouse, child, parent, brother or sister of that "employee" as a consequence of "bodily injury" described in Paragraph a. above.

This exclusion applies:

- a. Whether the insured may be liable as an employer or in any other capacity; and
- b. To any obligation to share damages with or repay someone else who must pay damages because of the "bodily injury".

**5. Pollution**

- a. "Bodily injury", "property damage", "personal injury" or "advertising injury" arising out of the actual, alleged or threatened discharge, dispersal, seepage, migration, release or escape of "pollutants".
- b. Any loss, cost or expense arising out of any:
  - (1) Request, demand, order or statutory or regulatory requirement that any insured or any other person or organization test for, monitor, clean up, remove, contain, treat, detoxify or neutralize, or in any way respond to, or assess the effects of, "pollutants"; or
  - (2) Claim or "suit" by or on behalf of any governmental authority or any other person or organization because of testing for, monitoring, cleaning up,

removing, containing, treating, detoxifying or neutralizing, or in any way responding to, or assessing the effects of, "pollutants".

**6. Aircraft**

"Bodily injury" or "property damage" arising out of the ownership, maintenance, use or entrustment to others of any aircraft owned or operated by or rented or loaned to any insured. Use includes operation and "loading or unloading".

This exclusion applies even if the claims against any insured allege negligence or other wrongdoing in the supervision, hiring, employment, training or monitoring of others by that insured, if the "occurrence" which caused the "bodily injury" or "property damage" involved the ownership, maintenance, use or entrustment to others of any aircraft that is owned or operated by or rented or loaned to any insured.

**7. Auto**

"Bodily injury" or "property damage" arising out of the ownership, maintenance, use or entrustment to others of any "auto". Use includes operation and "loading or unloading".

This exclusion applies even if the claims against any insured allege negligence or other wrongdoing in the supervision, hiring, employment, training or monitoring of others by that insured, if the "occurrence" which caused the "bodily injury" or "property damage" involved the ownership, maintenance, use or entrustment to others of any "auto".

This exclusion does not apply to "bodily injury" or "property damage" caused by an "occurrence" that takes place outside of the United States of America (including its territories and possessions), Puerto Rico and Canada.

**8. Watercraft**

"Bodily injury" or "property damage" arising out of the ownership, maintenance, use or entrustment to others of any watercraft owned or operated by or rented or loaned to any insured. Use includes operation and "loading or unloading".

This exclusion applies even if the claims against any insured allege negligence or other wrongdoing in the supervision, hiring, employment, training or monitoring of others by that insured, if the "occurrence" which caused the "bodily injury" or "property damage" involved the ownership,

maintenance, use or entrustment to others of any watercraft that is owned or operated by or rented or loaned to any insured.

This exclusion does not apply to a watercraft:

- a. While ashore on premises owned by or rented to any insured; or
- b. That is 50-feet long or less and that:
  - (1) You own; or
  - (2) You do not own and is not being used to carry any person or property for a charge.

**9. Electronic Data**

Damages claimed for the loss of, loss of use of, damage to, corruption of, inability to access, or inability to manipulate "electronic data".

**10. Damage To Property, Products Or Work**

"Property damage" to:

- a. Property you own, rent or occupy, including any costs or expenses incurred by you, or any other person or organization, for repair, replacement, enhancement, restoration or maintenance of such property for any reason, including prevention of injury to a person or damage to another's property;
- b. Premises you sell, give away or abandon if the "property damage" arises out of any part of those premises;
- c. Property loaned to you;
- d. Personal property in the care, custody or control of the insured;
- e. That particular part of real property on which you or any contractors or subcontractors working directly or indirectly on your behalf are performing operations if the "property damage" arises out of those operations;
- f. That particular part of any property that must be restored, repaired or replaced because "your work" was incorrectly performed on it;
- g. "Your product" arising out of "your product" or any part of it; or
- h. "Your work" arising out of "your work" or any part of it and included in the "products-completed operations hazard".

**11. Damage To Impaired Property Or Property Not Physically Injured**

"Property damage" to "impaired property", or property that has not been physically injured, arising out of:

- a. A defect, deficiency, inadequacy or dangerous condition in "your product" or "your work"; or
- b. A delay or failure by you, or anyone acting on your behalf, to fulfill the terms of a contract or agreement.

This exclusion does not apply to the loss of use of other property arising out of sudden and accidental physical injury to "your product" or "your work" after it has been put to its intended use.

**12. Recall Of Products, Work Or Impaired Property**

Damages claimed for any loss, cost or expense incurred by you or others for the loss of use, withdrawal, recall, inspection, repair, replacement, adjustment, removal or disposal of:

- a. "Your product";
- b. "Your work"; or
- c. "Impaired property";

if such product, work or property is withdrawn or recalled from the market or from use by any person or organization because of a known or suspected defect, deficiency, inadequacy or dangerous condition in it.

**13. Violation Of Consumer Financial Protection Laws**

"Bodily injury", "property damage", "personal injury" or "advertising injury" arising out of any actual or alleged violation of a "consumer financial protection law", or any other "bodily injury", "property damage", "personal injury" or "advertising injury" alleged in any claim or "suit" that also alleges any such violation.

**14. Unsolicited Communication**

"Bodily injury", "property damage", "personal injury" or "advertising injury" arising out of any actual or alleged violation of any law that restricts or prohibits the sending, transmitting or distributing of "unsolicited communication".

**15. Access Or Disclosure Of Confidential Or Personal Information**

"Bodily injury", "property damage", "personal injury" or "advertising injury" arising out of any access to or disclosure of any person's or organization's confidential or personal information.

**16. Knowing Violation Of Rights Of Another**

"Personal injury" or "advertising injury" caused by or at the direction of the insured with the knowledge that the act would violate the rights of another and would inflict "personal injury" or "advertising injury".

**17. Material Published With Knowledge Of Falsity**

"Personal injury" or "advertising injury" arising out of oral or written publication, including publication by electronic means, of material, if done by or at the direction of the insured with knowledge of its falsity.

**18. Material Published Or Used Prior To Policy Period**

- a. "Personal injury" or "advertising injury" arising out of oral or written publication, including publication by electronic means, of material whose first publication took place before the beginning of the policy period; or
- b. "Advertising injury" arising out of infringement of copyright, "title" or "slogan" in your "advertisement" whose first infringement in your "advertisement" was committed before the beginning of the policy period.

**19. Criminal Acts**

"Personal injury" or "advertising injury" arising out of a criminal act committed by or at the direction of the insured.

**20. Breach Of Contract**

"Personal injury" or "advertising injury" arising out of a breach of contract.

**21. Quality Or Performance Of Goods – Failure To Conform To Statements**

"Advertising injury" arising out of the failure of goods, products or services to conform with any statement of quality or performance made in your "advertisement".

**22. Wrong Description Of Prices**

"Advertising injury" arising out of the wrong description of the price of goods, products or services stated in your "advertisement".

**23. Intellectual Property**

"Personal injury" or "advertising injury" arising out of any actual or alleged infringement or violation of any of the following rights or laws, or any other "personal injury" or "advertising injury" alleged in any claim or "suit" that also alleges any such infringement or violation:

- a. Copyright;
- b. Patent;

- c. Trade dress;
- d. Trade name;
- e. Trademark;
- f. Trade secret; or
- g. Other intellectual property rights or laws.

This exclusion does not apply to:

- a. "Advertising injury" arising out of any actual or alleged infringement or violation of another's copyright, "title" or "slogan" in your "advertisement"; or
- b. Any other "personal injury" or "advertising injury" alleged in any claim or "suit" that also alleges any such infringement or violation of another's copyright, "title" or "slogan" in your "advertisement".

**24. Insureds In Media And Internet Type Business**

"Personal injury" or "advertising injury" arising out of an offense committed by an insured whose business is:

- a. Advertising, "broadcasting" or publishing;
- b. Designing or determining content of web-sites for others; or
- c. An Internet search, access, content or service provider.

This exclusion does not apply to Paragraphs **a.(1), (2) and (3)** of the definition of "personal injury".

For the purposes of this exclusion:

- a. Creating and producing correspondence written in the conduct of your business, bulletins, financial or annual reports, or newsletters about your goods, products or services will not be considered the business of publishing; and
- b. The placing of frames, borders or links, or advertising, for you or others anywhere on the Internet will not, by itself, be considered the business of advertising, "broadcasting" or publishing.

**25. Electronic Chatrooms Or Bulletin Boards**

"Personal injury" or "advertising injury" arising out of an electronic chatroom or bulletin board the insured hosts, owns or over which the insured exercises control.

**26. Unauthorized Use Of Another's Name Or Product**

"Personal injury" or "advertising injury" arising out of the unauthorized use of another's name or product in your e-mail address, domain name or metatag, or any other similar tactics to mislead another's potential customers.

**C. With respect to Coverage C:**

**Newly Acquired, Controlled Or Formed Entities**

"Crisis management service expenses" arising out of a "crisis management event" that involves any organization you newly acquire or form and that occurred prior to the date you acquired or formed that organization, even if an "executive officer" only first becomes aware of an "event" or "occurrence" that leads to such "crisis management event" after the date you acquired or formed such organization.

**SECTION V – CONDITIONS**

**A. APPEALS**

1. If the insured or the insured's "underlying insurer" elects not to appeal a judgment which exceeds the "applicable underlying limit" or "self-insured retention", we may do so.
2. If we appeal such a judgment, we will pay all costs of the appeal. These payments will not reduce the applicable limits of insurance. In no event will our liability exceed the applicable limit of insurance.

**B. BANKRUPTCY**

1. Bankruptcy or insolvency of the insured or of the insured's estate will not relieve us of our obligations under this insurance.
2. In the event of bankruptcy or insolvency of any "underlying insurer", this insurance will not replace such bankrupt or insolvent "underlying insurer's" policy, and this insurance will apply as if such "underlying insurer" had not become bankrupt or insolvent.

**C. CANCELLATION**

1. The first Named Insured shown in the Declarations may cancel this insurance by mailing or delivering to us advance written notice of cancellation.
2. We may cancel this insurance by mailing or delivering to such first Named Insured written notice of cancellation at least:
  - a. 10 days before the effective date of cancellation if we cancel for nonpayment of premium; or
  - b. 60 days before the effective date of cancellation if we cancel for any other reason.
3. We will mail or deliver our notice to such first Named Insured's last mailing address known to us.

4. Notice of cancellation will state the effective date of cancellation. The policy period will end on that date.
5. If this insurance is cancelled, we will send such first Named Insured any premium refund due. If we cancel, the refund will be pro rata. If such first Named Insured cancels, the refund may be less than pro rata. The cancellation will be effective even if we have not made or offered a refund.
6. If notice is mailed, proof of mailing will be sufficient proof of notice.

**D. CHANGES**

This policy contains all the agreements between you and us concerning the insurance afforded. No change can be made in the terms of this insurance except with our consent. The terms of this insurance can be amended or waived only by endorsement issued by us and made a part of this policy.

**E. CURRENCY**

Payments for damages or expenses described in Paragraph 5. of Paragraph D., **DEFENSE AND SUPPLEMENTARY PAYMENTS**, of **SECTION I – COVERAGES** will be in the currency of the United States of America. At our sole option, we may make these payments in a different currency. Any necessary currency conversion for such payments will be calculated based on the rate of exchange published in the Wall Street Journal immediately preceding the date the payment is processed.

**F. DUTIES REGARDING AN EVENT, OCCURRENCE, CLAIM OR SUIT**

1. You must see to it that we are notified as soon as practicable of an "event" or "occurrence" which may result in a claim under this insurance. To the extent possible, notice should include:
  - a. How, when and where the "event" or "occurrence" took place;
  - b. The names and addresses of any persons or organizations sustaining injury, damage or loss, and the names and addresses of any witnesses; and
  - c. The nature and location of any injury or damage arising out of the "event" or "occurrence".
2. If a claim is made or "suit" is brought against any insured which may result in a claim under this insurance, you must see to it that we receive written notice of the claim or "suit" as soon as practicable.

3. With respect to Coverage **A**, the insured must:
  - a. Cooperate with us in the investigation, settlement or defense of any claim or "suit";
  - b. Comply with the terms of the "underlying insurance"; and
  - c. Pursue all rights of contribution or indemnity against any person or organization who may be liable to the insured because of the injury, damage or loss for which insurance is provided under this policy or any policy of "underlying insurance".
4. With respect to Coverage **B**, the insured must:
  - a. Immediately send us copies of any demands, notices, summonses or legal papers received in connection with the claim or "suit";
  - b. Authorize us to obtain necessary records and other information;
  - c. Cooperate with us in the investigation, settlement or defense of any claim or "suit"; and
  - d. Assist us, upon our request, in the enforcement of any right against any person or organization which may be liable to the insured because of injury or damage to which Coverage **B** may apply.
5. No insured will, except at that insured's own expense, voluntarily make a payment, assume any obligation, make any admission or incur any expense, other than for first aid for "bodily injury" covered by this insurance, without our consent.
6. Knowledge of an "event", "occurrence", claim or "suit" by your agent, servant or "employee" will not constitute knowledge by you, unless your insurance or risk manager, or anyone working in the capacity as your insurance or risk manager, or anyone you designate with the responsibility of reporting an "event", "occurrence", claim or "suit":
  - a. Has received notice of such "event", "occurrence", claim or "suit" from such agent, servant or "employee"; or
  - b. Otherwise has knowledge of such "event", "occurrence", claim or "suit".

## **G. DUTIES REGARDING A CRISIS MANAGEMENT EVENT**

You must:

1. Notify us within 30 days of a "crisis management event" that may result in "crisis management service expenses".
2. Provide written notice of the "crisis management event" as soon as practicable. To the extent possible, notice should include:
  - a. How, when and where that "crisis management event" took place;
  - b. The names and addresses of any persons or organizations sustaining injury, damage or loss, and the named and addresses of any witnesses;
  - c. The nature and location of any injury or damage arising out of that "crisis management event"; and
  - d. The reason that "crisis management event" is likely to involve damages covered by this insurance in excess of the "applicable underlying limit" or "self-insured retention" and involve regional or national media coverage.

## **H. EXAMINATION OF YOUR BOOKS AND RECORDS**

We may examine and audit your books and records as they relate to this insurance:

1. At any time during the policy period;
2. Up to three years after the end of the policy period; and
3. Within one year after final settlement of all claims under this insurance.

## **I. EXTENDED REPORTING PERIOD OPTION**

1. When the "underlying insurance" applies on a claims-made basis, any automatic or basic "extended reporting period" in such "underlying insurance" will apply to this insurance.
2. When the "underlying insurance" applies on a claims-made basis and you elect to purchase an optional or supplemental "extended reporting period" in such "underlying insurance," that "extended reporting period" will apply to this insurance only if:
  - a. A written request to purchase an Extended Reporting Period endorsement for this insurance is made by you and received by us within 90 days after the end of the policy period;

- b. You have paid all premiums due for this policy at the time you make such request;
  - c. You promptly pay the additional premium we charge for the Extended Reporting Period endorsement for this insurance when due. We will determine that additional premium after we have received your request for the Extended Reporting Period endorsement for this insurance. That additional premium is not subject to any limitation stated in the "underlying insurance" on the amount or percentage of additional premium that may be charged for the "extended reporting period" in such "underlying insurance"; and
  - d. That Extended Reporting Period endorsement is issued by us and made a part of this policy.
3. Any Extended Reporting Period endorsement for this insurance will not reinstate or increase the Limits of Insurance or extend the policy period.
  4. Except with respect to any provisions to the contrary contained in Paragraphs 1., 2. or 3. above, all provisions of any option to purchase an "extended reporting period" granted to you in the "underlying insurance" apply to this insurance.

**J. INSPECTIONS AND SURVEYS**

1. We have the right but are not obligated to:
  - a. Make inspections and surveys at any time;
  - b. Give you reports on the conditions we find; and
  - c. Recommend changes.
2. Any inspections, surveys, reports or recommendations relate only to insurability and the premiums to be charged. We do not make safety inspections. We do not undertake to perform the duty of any person or organization to provide for the health or safety of workers or the public. We do not warrant that conditions:
  - a. Are safe or healthful; or
  - b. Comply with laws, regulations, codes or standards.

**K. LEGAL ACTION AGAINST US**

1. No person or organization has a right under this insurance:
  - a. To join us as a party or otherwise bring us into a "suit" asking for damages from an insured; or

- b. To sue us on this insurance unless all of its terms have been fully complied with.
2. A person or organization may sue us to recover on an agreed settlement or on a final judgment against an insured. We will not be liable for damages that:
    - a. Are not payable under the terms of this insurance; or
    - b. Are in excess of the applicable limit of insurance.

An agreed settlement means a settlement and release of liability signed by us, the insured and the claimant or the claimant's legal representative.

**L. MAINTENANCE OF UNDERLYING INSURANCE**

1. The insurance afforded by each policy of "underlying insurance" will be maintained for the full policy period of this Excess Follow-Form And Umbrella Liability Insurance. This provision does not apply to the reduction or exhaustion of the aggregate limit or limits of such "underlying insurance" solely by payments as permitted in Paragraphs 4.a.(1), (2) and (3) of **COVERAGE A – EXCESS FOLLOW-FORM LIABILITY** of **SECTION I – COVERAGES**. As such policies expire, you will renew them at limits and with coverage at least equal to the expiring limits of insurance. If you fail to comply with the above requirements, Coverage A is not invalidated. However, in the event of a loss, we will pay only to the extent that we would have paid had you complied with the above requirements.
2. The first Named Insured shown in the Declarations must give us written notice of any change in the "underlying insurance" as respects:
  - a. Coverage;
  - b. Limits of insurance;
  - c. Termination of any coverage; or
  - d. Exhaustion of aggregate limits.
3. If you are unable to recover from any "underlying insurer" because you fail to comply with any term or condition of the "underlying insurance", Coverage A is not invalidated. However, we will pay for any loss only to the extent that we would have paid had you complied with that term or condition in that "underlying insurance".

**M. OTHER INSURANCE**

This insurance is excess over any valid and collectible "other insurance" whether such "other insurance" is stated to be primary, contributing,



excess, contingent or otherwise. This provision does not apply to a policy bought specifically to apply as excess of this insurance.

However, if you specifically agree in a written contract or agreement that the insurance provided to any person or organization that qualifies as an insured under this insurance must apply on a primary basis, or a primary and non-contributory basis, then insurance provided under Coverage A is subject to the following provisions:

1. This insurance will apply before any "other insurance" that is available to such additional insured which covers that person or organization as a named insured, and we will not share with that "other insurance", provided that the injury or damage for which coverage is sought is caused by an "event" that takes place or is committed subsequent to the signing of that contract or agreement by you.
2. This insurance is still excess over any valid and collectible "other insurance", whether primary, excess, contingent or otherwise, which covers that person or organization as an additional insured or as any other insured that does not qualify as a named insured.

#### **N. PREMIUM**

1. The first Named Insured shown in the Declarations is responsible for the payment of all premiums and will be the payee for any return premiums.
2. If the premium is a flat charge, it is not subject to adjustment except as provided in Paragraph 4. below.
3. If the premium is other than a flat charge, it is an advance premium only. The earned premium will be computed at the end of the policy period, or at the end of each year of the policy period if the policy period is two years or longer, at the rate shown in the Declarations, subject to the Minimum Premium.
4. Additional premium may become payable when coverage is provided for additional insureds under the provisions of **SECTION II – WHO IS AN INSURED**.

#### **O. PREMIUM AUDIT**

The premium for this policy is the amount stated in Item 5. of the Declarations. The premium is a flat charge unless it is specified in the Declarations as adjustable.

#### **P. PROHIBITED COVERAGE – UNLICENSED INSURANCE**

1. With respect to loss sustained by any insured in a country or jurisdiction in which we are not licensed to provide this insurance, this insurance does not apply to the extent that insuring such loss would violate the laws or regulations of such country or jurisdiction.
2. We do not assume responsibility for:
  - a. The payment of any fine, fee, penalty or other charge that may be imposed on any person or organization in any country or jurisdiction because we are not licensed to provide insurance in such country or jurisdiction; or
  - b. The furnishing of certificates or other evidence of insurance in any country or jurisdiction in which we are not licensed to provide insurance.

#### **Q. PROHIBITED COVERAGE – TRADE OR ECONOMIC SANCTIONS**

We will provide coverage for any loss, or otherwise will provide any benefit, only to the extent that providing such coverage or benefit does not expose us or any of our affiliated or parent companies to:

1. Any trade or economic sanction under any law or regulation of the United States of America; or
2. Any other applicable trade or economic sanction, prohibition or restriction.

#### **R. REPRESENTATIONS**

By accepting this insurance, you agree:

1. The statements in the Declarations and any subsequent notice relating to "underlying insurance" are accurate and complete;
2. Those statements are based upon representations you made to us; and
3. We have issued this insurance in reliance upon your representations.

#### **S. SEPARATION OF INSUREDS**

Except with respect to the Limits of Insurance, and any rights or duties specifically assigned in this policy to the first Named Insured shown in the Declarations, this insurance applies:

1. As if each Named Insured were the only Named Insured; and
2. Separately to each insured against whom claim is made or "suit" is brought.

**T. WAIVER OR TRANSFER OF RIGHTS OF RECOVERY AGAINST OTHERS TO US**

1. If the insured has rights to recover all or part of any payment we have made under this insurance, those rights are transferred to us and the insured must do nothing after loss to impair them. At our request, the insured will bring suit or transfer those rights to us and help us, and with respect to Coverage A, the "underlying insurer", enforce them.

If the insured has agreed in a contract or agreement to waive that insured's right of recovery against any person or organization, we waive our right of recovery against that person or organization, but only for payments we make because of an "event" that takes place or is committed subsequent to the execution of that contract or agreement by such insured.

2. Reimbursement of any amount recovered will be made in the following order:
- a. First, to any person or organization (including us or the insured) who has paid any amount in excess of the applicable limit of insurance;
  - b. Next, to us; and
  - c. Then, to any person or organization (including the insured and with respect to Coverage A, the "underlying insurer") that is entitled to claim the remainder, if any.
3. Expenses incurred in the process of recovery will be divided among all persons or organizations receiving amounts recovered according to the ratio of their respective recoveries.

**U. TRANSFER OF YOUR RIGHTS AND DUTIES UNDER THIS INSURANCE**

- 1. Your rights and duties under this insurance may not be transferred without our written consent except in the case of death of an individual Named Insured.
- 2. If you die, your rights and duties will be transferred to your legal representative but only while acting within the scope of duties as your legal representative. Until your legal representative is appointed, anyone having proper temporary custody of your property will have your rights and duties but only with respect to that property.

**V. UNINTENTIONAL OMISSION OR ERROR**

The unintentional omission of, or unintentional error in, any information provided by you which we relied upon in issuing this policy will not prejudice your rights under this insurance. However, this

provision does not affect our right to collect additional premium or to exercise our rights of cancellation or nonrenewal in accordance with applicable insurance laws or regulations.

**W. WHEN LOSS IS PAYABLE**

If we are liable under this insurance, we will pay for injury, damage or loss after:

- 1. The insured's liability is established by:
  - a. A court decision; or
  - b. A written agreement between the claimant, the insured, any "underlying insurer" and us; and
- 2. The amount of the "applicable underlying limit" or "self-insured retention" is paid by or on behalf of the insured.

**SECTION VI – DEFINITIONS**

A. With respect to all coverages of this insurance:

- 1. "Applicable underlying limit" means the sum of:
  - a. The applicable limit of insurance stated for the policies of "underlying insurance" in the Schedule Of Underlying Insurance subject to the provisions in Paragraphs 4.a.(1), (2) and (3) of **COVERAGE A – EXCESS FOLLOW-FORM LIABILITY of SECTION I – COVERAGES**; and
  - b. The applicable limit of insurance of any "other insurance" that applies.

The limits of insurance in any policy of "underlying insurance" will apply even if:

  - a. The "underlying insurer" claims the insured failed to comply with any term or condition of the policy; or
  - b. The "underlying insurer" becomes bankrupt or insolvent.
- 2. "Auto hazard" means all "bodily injury" and "property damage" to which liability insurance afforded under an auto policy of "underlying insurance" would apply but for the exhaustion of its applicable limits of insurance.
- 3. "Electronic data" means information, facts or programs stored as or on, created or used on, or transmitted to or from computer software (including systems and applications software), hard or floppy disks, CD-ROMs, tapes, drives, cells, data processing devices or any other media which are used with electronically controlled equipment.
- 4. "Event" means an "occurrence", offense, accident, act, error, omission, wrongful act or loss.

5. "Extended reporting period" means any period of time, starting with the end of the policy period of your claims-made insurance, during which claims or "suits" may be first made, brought or reported for that insurance.
6. "Medical expenses" means expenses to which any Medical Payments section of any policy of Commercial General Liability "underlying insurance" applies.
7. "Other insurance" means insurance, or the funding of losses, that is provided by, through or on behalf of:
  - a. Another insurance company;
  - b. Us or any of our affiliated insurance companies;
  - c. Any risk retention group;
  - d. Any self-insurance method or program, in which case the insured will be deemed to be the provider of such insurance; or
  - e. Any similar risk transfer or risk management method.

"Other insurance" does not include:

- a. Any "underlying insurance"; or
  - b. Any policy of insurance specifically purchased to be excess of the limits of insurance of this policy shown in the Declarations.
8. "Products-completed operations hazard":
    - a. Includes all "bodily injury" and "property damage" occurring away from premises you own or rent and arising out of "your product" or "your work" except:
      - (1) Products that are still in your physical possession; or
      - (2) Work that has not yet been completed or abandoned. However, "your work" will be deemed completed at the earliest of the following times:
        - (a) When all the work called for in your contract has been completed;
        - (b) When all the work to be done at the job site has been completed if your contract calls for work at more than one job site; or
        - (c) When that part of the work done at a job site has been put to its intended use by any person or organization other than another contractor or subcontractor working on the same project.

Work that may need service, maintenance, correction, repair or replacement, but which is otherwise complete, will be treated as completed.

- b. Does not include "bodily injury" or "property damage" arising out of:
  - (1) The transportation of property, unless the injury or damage arises out of a condition in or on a vehicle not owned or operated by you, and that condition was created by the "loading or unloading" of that vehicle by any insured;
  - (2) The existence of tools, uninstalled equipment or abandoned or unused materials; or
  - (3) Products or operations for which the classification listed in a policy of Commercial General Liability "underlying insurance" states that products-completed operations are subject to the General Aggregate Limit.
9. "Suit" means a civil proceeding which alleges damages. "Suit" includes:
  - a. An arbitration proceeding in which damages are claimed and to which the insured must submit or does submit with our consent; or
  - b. Any other alternative dispute resolution proceeding to which the insured submits with our consent.
10. "Underlying insurance":
  - a. Means the policy or policies of insurance listed in the Schedule Of Underlying Insurance.
  - b. Includes any renewal or replacement of such policies if such renewal or replacement is during the policy period of this Excess Follow-Form And Umbrella Liability Insurance.
  - c. Does not include any part of the policy period of any of the policies described in Paragraphs a. or b. above that began before, or that continues after, the policy period of this Excess Follow-Form And Umbrella Liability Insurance.
11. "Underlying insurer" means any insurer which provides a policy of insurance listed in the Schedule Of Underlying Insurance.

**B.** With respect to Coverage **B** and, to the extent that the following terms are not defined in the "underlying insurance", to Coverage **A**:

**1.** "Advertisement" means a notice that is broadcast or published to the general public or specific market segments about your goods, products or services for the purpose of attracting customers or supporters. For the purposes of this definition:

- a.** Notices that are published include material placed on the Internet or on similar electronic means of communication; and
- b.** Regarding web sites, only that part of a web site that is about your goods, products or services for the purposes of attracting customers or supporters is considered an advertisement.

**2.** "Advertising injury":

**a.** Means injury, other than "personal injury", caused by one or more of the following offenses:

- (1)** Oral or written publication, including publication by electronic means, of material in your "advertisement" that slanders or libels a person or organization or disparages a person's or organization's goods, products or services, provided that the claim is made or the "suit" is brought by a person or organization that claims to have been slandered or libeled, or that claims to have had its goods, products or services disparaged;
- (2)** Oral or written publication, including publication by electronic means, of material in your "advertisement" that:
  - (a)** Appropriates a person's name, voice, photograph or likeness; or
  - (b)** Unreasonably places a person in a false light; or
- (3)** Infringement of copyright, "title" or "slogan" in your "advertisement", provided that the claim is made or the "suit" is brought by a person or organization that claims ownership of such copyright, "title" or "slogan".

**b.** Includes "bodily injury" caused by one or more of the offenses described in Paragraph **a.** above.

**3.** "Auto" means:

**a.** A land motor vehicle, trailer or semitrailer designed for travel on public roads,

including any attached machinery or equipment; or

**b.** Any other land vehicle that is subject to a compulsory or financial responsibility law or other motor vehicle insurance law where it is licensed or principally garaged.

However, "auto" does not include "mobile equipment".

**4.** "Bodily injury" means:

- a.** Physical harm, including sickness or disease, sustained by a person; or
- b.** Mental anguish, injury or illness, or emotional distress, resulting at any time from such physical harm, sickness or disease.

**5.** "Broadcasting" means transmitting any audio or visual material for any purpose:

- a.** By radio or television; or
- b.** In, by or with any other electronic means of communication, such as the Internet, if that material is part of:

- (1)** Radio or television programming being transmitted;
- (2)** Other entertainment, educational, instructional, music or news programming being transmitted; or
- (3)** Advertising transmitted with any such programming.

**6.** "Consumer financial identity information" means any of the following information for a person that is used or collected for the purpose of serving as a factor in establishing such person's eligibility for personal credit, insurance or employment or for the purpose of conducting a business transaction:

- a.** Part or all of the account number, the expiration date or the balance of any credit, debit, bank or other financial account;
- b.** Information bearing on a person's credit worthiness, credit standing or credit capacity;
- c.** Social security number;
- d.** Driver's license number; or
- e.** Birth date.

**7.** "Consumer financial protection law" means:

**a.** The Fair Credit Reporting Act (FCRA) and any of its amendments, including the Fair and Accurate Credit Transactions Act (FACTA);

- b.** California's Song-Beverly Credit Card Act and any of its amendments; or
- c.** Any other law or regulation that restricts or prohibits the collection, dissemination, transmission, distribution or use of "consumer financial identity information".
- 8.** "Employee" includes a "leased worker". "Employee" does not include a "temporary worker".
- 9.** "Good Samaritan services" means any emergency medical services for which no compensation is demanded or received.
- 10.** "Impaired property" means tangible property, other than "your product" or "your work", that cannot be used or is less useful because:
- a.** It incorporates "your product" or "your work" that is known or thought to be defective, deficient, inadequate or dangerous; or
- b.** You have failed to fulfill the terms of a contract or agreement;
- if such property can be restored to use by the repair, replacement, adjustment or removal of "your product" or "your work" or your fulfilling the terms of the contract or agreement.
- 11.** "Leased worker" means a person leased to you by a labor leasing firm under an agreement between you and the labor leasing firm, to perform duties related to the conduct of your business. "Leased worker" does not include a "temporary worker".
- 12.** "Loading or unloading" means the handling of property:
- a.** After it is moved from the place where it is accepted for movement into or onto an aircraft, watercraft or "auto";
- b.** While it is in or on an aircraft, watercraft or "auto"; or
- c.** While it is being moved from an aircraft, watercraft or "auto" to the place where it is finally delivered;
- but "loading or unloading" does not include the movement of property by means of a mechanical device, other than a hand truck, that is not attached to the aircraft, watercraft or "auto".
- 13.** "Mobile equipment" means any of the following types of land vehicles, including any attached machinery or equipment:
- a.** Bulldozers, farm machinery, forklifts and other vehicles designed for use principally off public roads.
- b.** Vehicles maintained for use solely on or next to premises you own or rent.
- c.** Vehicles that travel on crawler treads.
- d.** Vehicles, whether self-propelled or not, maintained primarily to provide mobility to permanently mounted:
- (1)** Power cranes, shovels, loaders, diggers or drills; or
- (2)** Road construction or resurfacing equipment such as graders, scrapers or rollers.
- e.** Vehicles not described in Paragraph **a.**, **b.**, **c.** or **d.** above that are not self-propelled and are maintained primarily to provide mobility to permanently attached equipment of the following types:
- (1)** Air compressors, pumps and generators, including spraying, welding, building cleaning, geophysical exploration, lighting and well servicing equipment; or
- (2)** Cherry pickers and similar devices used to raise or lower workers.
- f.** Vehicles not described in Paragraph **a.**, **b.**, **c.** or **d.** above maintained primarily for purposes other than the transportation of persons or cargo.
- However, self-propelled vehicles with the following types of permanently attached equipment are not "mobile equipment" but will be considered "autos":
- (1)** Equipment designed primarily for:
- (a)** Snow removal;
- (b)** Road maintenance, but not construction or resurfacing; or
- (c)** Street cleaning;
- (2)** Cherry pickers and similar devices mounted on automobile or truck chassis and used to raise or lower workers; and
- (3)** Air compressors, pumps and generators, including spraying, welding, building cleaning, geophysical exploration, lighting and well servicing equipment.
- However, "mobile equipment" does not include any land vehicle that is subject to a compulsory or financial responsibility law, or other motor vehicle insurance law, where it is licensed or principally garaged. Such land vehicles are considered "autos".

- 14. "Occurrence" means:**
- a.** With respect to "bodily injury" or "property damage":
    - (1)** An accident, including continuous or repeated exposure to substantially the same general harmful conditions, which results in "bodily injury" or "property damage". All "bodily injury" or "property damage" caused by such exposure to substantially the same general harmful conditions will be deemed to be caused by one "occurrence"; or
    - (2)** An act or omission committed in providing or failing to provide first aid or "Good Samaritan services" to a person by any of your "employees" or "volunteer workers" other than an employed or volunteer doctor, unless you are in the business or occupation of providing professional health care services;
  - b.** With respect to "personal injury", an offense arising out of your business that results in "personal injury". All "personal injury" caused by the same or related injurious material, act or offense will be deemed to be caused by one "occurrence", regardless of the frequency or repetition thereof, the number and kind of media used or the number of persons or organizations making claims or bringing "suits"; and
  - c.** With respect to "advertising injury", an offense committed in the course of advertising your goods, products and services that results in "advertising injury". All "advertising injury" caused by the same or related injurious material, act or offense will be deemed to be caused by one "occurrence", regardless of the frequency or repetition thereof, the number and kind of media used or the number of persons or organizations making claims or bringing "suits".
- 15. "Officer" means a person holding any of the officer positions created by your charter, constitution, bylaws or any other similar governing document.**
- 16. "Personal injury":**
- a.** Means injury, other than "advertising injury", caused by one or more of the following offenses:
    - (1)** False arrest, detention or imprisonment;
    - (2)** Malicious prosecution;
    - (3)** The wrongful eviction from, wrongful entry into, or invasion of the right of private occupancy of a room, dwelling or premises that a person occupies, provided that the wrongful eviction, wrongful entry or invasion of the right of private occupancy is committed by or on behalf of the owner, landlord or lessor of that room, dwelling or premises;
    - (4)** Oral or written publication, including publication by electronic means, of material that slanders or libels a person or organization or disparages a person's or organization's goods, products or services, provided that the claim is made or the "suit" is brought by a person or organization that claims to have been slandered or libeled, or that claims to have had its goods, products or services disparaged; or
    - (5)** Oral or written publication, including publication by electronic means, of material that:
      - (a)** Appropriates a person's name, voice, photograph or likeness; or
      - (b)** Unreasonably places a person in a false light.
  - b.** Includes "bodily injury" caused by one or more of the offenses described in Paragraph **a.** above.
- 17. "Pollutants" mean any solid, liquid, gaseous or thermal irritant or contaminant, including smoke, vapor, soot, fumes, acids, alkalis, chemicals and waste. Waste includes materials to be recycled, reconditioned or reclaimed.**
- 18. "Property damage" means:**
- a.** Physical injury to tangible property, including all resulting loss of use of that property. All such loss of use will be deemed to occur at the time of the physical injury that caused it; or
  - b.** Loss of use of tangible property that is not physically injured. All such loss of use will be deemed to occur at the time of the "occurrence" that caused it.
- For the purposes of this insurance, "electronic data" is not tangible property.
- 19. "Self-insured retention" is the greater of:**
- a.** The amount shown in the Declarations which the insured must first pay under Coverage **B** for damages because of all

"bodily injury", "property damage", "personal injury" or "advertising injury" arising out of any one "occurrence"; or

- b. The applicable limit of insurance of any "other insurance" that applies.

**20. "Slogan":**

a. Means a phrase that others use for the purpose of attracting attention in their advertising.

b. Does not include a phrase used as, or in, the name of:

(1) Any person or organization other than you; or

(2) Any business, or any of the premises, goods, products, services or work, of any person or organization other than you.

**21. "Temporary worker"** means a person who is furnished to you to substitute for a permanent "employee" on leave or to meet seasonal or short-term workload conditions.

**22. "Title"** means the name of a literary or artistic work.

**23. "Unsolicited communication"** means any communication, in any form, that the recipient of such communication did not specifically request to receive.

**24. "Volunteer worker"** means a person who is not your "employee", and who donates his or her work and acts at the direction of and within the scope of duties determined by you, and is not paid a fee, salary or other compensation by you or anyone else for their work performed by you.

**25. "Your product":**

a. Means:

(1) Any goods or products, other than real property, manufactured, sold, handled, distributed or disposed of by:

(a) You;

(b) Others trading under your name; or

(c) A person or organization whose business or assets you have acquired; and

(2) Containers (other than vehicles), materials, parts or equipment furnished in connection with such goods or products.

b. Includes:

(1) Warranties or representations made at any time with respect to the fitness, quality, durability, performance or use of "your product"; and

(2) The providing of or failure to provide warnings or instructions.

c. Does not include vending machines or other property rented to or located for the use of others but not sold.

**26. "Your work":**

a. Means:

(1) Work or operations performed by you or on your behalf; and

(2) Materials, parts or equipment furnished in connection with such work or operations.

b. Includes:

(1) Warranties or representations made at any time with respect to the fitness, quality, durability, performance or use of "your work"; and

(2) The providing of or failure to provide warnings or instructions.

**C. With respect to Coverage C:**

1. "Crisis management advisor" means any public relations firm or crisis management firm approved by us that is hired by you to perform "crisis management services" in connection with a "crisis management event".

2. "Crisis management event" means an "event" or "occurrence" that your "executive officer" reasonably determines has resulted, or may result, in:

a. Damages covered by this Coverage **A** or Coverage **B** that are in excess of the total applicable limits of the "underlying insurance" or "self-insured retention"; and

b. Significant adverse regional or national media coverage.

3. "Crisis management service expenses" means amounts incurred by you, after a "crisis management event" first commences and before such event ends:

a. For the reasonable and necessary:

(1) Fees and expenses of a "crisis management advisor" in the performance for you of "crisis management services" solely for a "crisis management event"; and

- (2) Costs for printing, advertising, mailing of materials or travel by your directors, officers, employees or agents or a "crisis management advisor" solely for a "crisis management event"; and
- b. For the following expenses resulting from such "crisis management event", provided that such expenses have been approved by us:

  - (1) Medical expenses;
  - (2) Funeral expenses;
  - (3) Psychological counseling;
  - (4) Travel expenses;
  - (5) Temporary living expenses;
  - (6) Expenses to secure the scene of a "crisis management event"; or
  - (7) Any other expenses pre-approved by us.
- 4. "Crisis management services" means those services performed by a "crisis management advisor" in advising you or minimizing potential harm to you from a "crisis management event" by maintaining or restoring public confidence in you.
- 5. "Executive officer" means your:

  - a. Chief Executive Officer;
  - b. Chief Operating Officer;
  - c. Chief Financial Officer;
  - d. President;
  - e. General Counsel;
  - f. General partner (if you are a partnership); or
  - g. Sole proprietor (if you are a sole proprietorship);

or any person acting in the same capacity as any individual listed above.



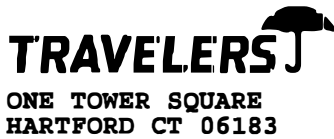

**WORKERS COMPENSATION  
AND  
EMPLOYERS LIABILITY POLICY**

**ENDORSEMENT WC 99 03 76 ( A ) - 001**

POLICY NUMBER: UB-4W50450A-24-14-G

**WAIVER OF OUR RIGHT TO RECOVER FROM OTHERS  
ENDORSEMENT – CALIFORNIA  
(BLANKET WAIVER)**

We have the right to recover our payments from anyone liable for an injury covered by this policy. We will not enforce our right against the person or organization named in the Schedule.

The additional premium for this endorsement shall be 2.00 % of the California workers' compensation premium.

**Schedule**

**Person or Organization**

**Job Description**

**ANY PERSON OR ORGANIZATION FOR WHICH THE INSURED HAS AGREED BY WRITTEN CONTRACT EXECUTED PRIOR TO LOSS TO FURNISH THIS WAIVER.**

This endorsement changes the policy to which it is attached and is effective on the date issued unless otherwise stated.

**(The information below is required only when this endorsement is issued subsequent to preparation of the policy.)**

Endorsement Effective 3/10/2024

Policy No. UB-4W50450A-24-14-G

Endorsement No.  
Premium

Insured: Bender CCP, Inc.

Countersigned by \_\_\_\_\_

Insurance Company: Travelers Property Casualty Co of America

[Business Lookup](#)**License Information:**[New search](#) [Back to results](#)

**Entity name:** BENDER CCP, INC.

**Business name:** BENDER CCP

**Entity type:** [Profit Corporation](#)

**UBI #:** 604-395-964

**Business ID:** 001

**Location ID:** 0001

**Location:** Active

**Location address:** 2150 E 37TH ST  
VERNON CA 90058-1417

**Mailing address:** PO BOX 847  
BENICIA CA 94510-0847

**Excise tax and reseller permit status:** [Click here](#)**Secretary of State status:** [Click here](#)**Endorsements**

Endorsements held at this	License #	Count	Details	Status	Expiration date	First issuance
<a href="#">Spokane General Business - Non-Resident</a>				Active	Aug-31-2024	Aug-03-2023

**Governing People** May include governing people not registered with Secretary of State

Governing people	Title
------------------	-------

POTTER, MICHAEL	
-----------------	--

**Registered Trade Names**

**Registered trade names**

**Status**

**First issued**

S & S WELDING

Active

Oct-07-2021

[View Additional Locations](#)

The Business Lookup information is updated nightly. Search date and time:  
5/9/2024 8:23:54 AM

**Contact us**

How are we doing?

**Take our survey!**

Don't see what you expected?

**Check if your browser is supported**





**Agenda Sheet for City Council:**

**Committee:** PIES **Date:** 05/20/2024

**Committee Agenda type:** Consent

**Date Rec'd** 5/20/2024

**Clerk's File #** OPR 2024-0458

**Cross Ref #**

**Project #**

**Council Meeting Date:** 06/10/2024

<b>Submitting Dept</b>	WATER & HYDROELECTRIC SERVICES	<b>Bid #</b>	6095-24
------------------------	--------------------------------	--------------	---------

<b>Contact Name/Phone</b>	LOREN SEARL 625-7821	<b>Requisition #</b>	VB
---------------------------	----------------------	----------------------	----

<b>Contact E-Mail</b>	LSEARL@SPOKANECITY.ORG		
-----------------------	------------------------	--	--

<b>Agenda Item Type</b>	Purchase w/o Contract		
-------------------------	-----------------------	--	--

<b>Council Sponsor(s)</b>	BWILKERSON JBINGLE KKLITZKE		
---------------------------	-----------------------------	--	--

<b>Agenda Item Name</b>	4100 APPROVAL OF VALUE BLANKET ORDER FOR BUTTERFLY VALVES		
-------------------------	---	--	--

**Agenda Wording**

Five (5) year value blanket with Consolidated Supply (Spokane, WA) for purchase of imported and domestic butterfly valves on an as-needed basis. Annual spend is estimated at \$300,000.00 including tax.

**Summary (Background)**

Request for Quotes 6095-24 was opened on 4-10-24 for the annual supply of butterfly valves on an "as needed" basis. Bids were accepted until 4-29-24. Three responses were received with Consolidated Supply as the low responsive bidder with the longest expected delivery.

Lease? NO Grant related? NO Public Works? YES

**Fiscal Impact**

Approved in Current Year Budget? YES

Total Cost	\$ 1,500,000.00
------------	-----------------

Current Year Cost	\$ 300,000.00
-------------------	---------------

Subsequent Year(s) Cost	\$ 300,000.00
-------------------------	---------------

**Narrative**

Five-year value blanket with no renewal options. Annual spend not to exceed \$300,000.00

**Amount**

**Budget Account**

Expense	\$ 1,500,000.00	# 4100-42440-94340-56595-99999
Select	\$	#
Select	\$	#
Select	\$	#
	\$	#
	\$	#



## Committee Agenda Sheet

### Public Infrastructure, Environment & Sustainability Committee

<b>Committee Date</b>	5-20-24
<b>Submitting Department</b>	Water & Hydroelectric Services
<b>Contact Name</b>	Loren Searl
<b>Contact Email &amp; Phone</b>	<a href="mailto:lsearl@spokanecity.org">lsearl@spokanecity.org</a> 509-625-7821
<b>Council Sponsor(s)</b>	Wilkerson, Bingle, Klitzke
<b>Select Agenda Item Type</b>	<input checked="" type="checkbox"/> Consent <input type="checkbox"/> Discussion    Time Requested: Purchase w/o Contract
<b>Agenda Item Name</b>	4100 Approval of Value Blanket order for Butterfly Valves
<b>Proposed Council Action</b>	<input type="checkbox"/> Approval to proceed to Legislative Agenda <input type="checkbox"/> Information Only
<b>Summary (Background)</b>	Request for Quotes 6095-24 was opened on 4-10-24 for the annual supply of butterfly valves on an "as needed" basis. Bids were accepted until 4-29-24. Three responses were received with Consolidated Supply as the low responsive bidder. American AVK came in as the shortest delivery timeline. This Order will be set up as a two (2) five (5) year Value Blanket Orders and the department will order from lowest cost with no delivery date deadline, or from slightly higher cost with quick delivery date deadline.
<p>*use the Fiscal Impact box below for relevant financial information</p>	<p><b>Fiscal Impact</b></p> <p><b>Approved in current year budget?</b>    <input checked="" type="checkbox"/> Yes    <input type="checkbox"/> No    <input type="checkbox"/> N/A</p> <p>Total Cost: <u>1,500,000.00</u></p> <p style="padding-left: 20px;">Current year cost: 300,000.00</p> <p style="padding-left: 20px;">Subsequent year(s) cost: 300,000.00</p> <p><b>Narrative:</b> Please provide financial due diligence review, as applicable, such as number and type of positions, grant match requirements, summary type details (personnel, maintenance and supplies, capital, revenue), impact on rates, fees, or future shared revenue</p> <p><b>Funding Source</b>    <input type="checkbox"/> One-time    <input type="checkbox"/> Recurring    <input type="checkbox"/> N/A</p> <p>Specify funding source: Select Funding Source*</p> <p>Is this funding source sustainable for future years, months, etc? <a href="#">Click or tap here to enter text.</a></p> <p><b>Expense Occurrence</b>    <input type="checkbox"/> One-time    <input type="checkbox"/> Recurring    <input type="checkbox"/> N/A</p> <p>Other budget impacts: (revenue generating, match requirements, etc.)</p>
<b>Operations Impacts (If N/A, please give a brief description as to why)</b>	
<ul style="list-style-type: none"> <li>• What impacts would the proposal have on historically excluded communities? Public works services and projects are designed to serve all citizens and businesses. We strive to offer a consistent level of service to all, to distribute public investment throughout the community and to</li> </ul>	

respond to gaps in services identified in various City plans. We recognize the need to maintain affordability and predictability for utility customers and we are committed to delivering work that is both financially and environmentally responsible. This project is specifically designed to assist low-income residents get caught up on their City utility bills.

- How will data be collected, analyzed, and reported concerning the effect of the program/policy by racial, ethnic, gender identity, national origin, income level, disability, sexual orientation, or other existing disparities?

N/A

- How will data be collected regarding the effectiveness of this program, policy, or product to ensure it is the right solution?

Public Works follows the City's established procurement and public works bidding regulations and policies to bring items forward, and then uses contract management best practices to ensure desired outcomes and regulatory compliance.

- Describe how this proposal aligns with current City Policies, including the Comprehensive Plan, Sustainability Action Plan, Capital Improvement Program, Neighborhood Master Plans, Council Resolutions, and others?

This work is consistent with annual budget strategies to limit costs and approved projects in the 6-year CIP.

#### **Council Subcommittee Review**

- Please provide a summary of council subcommittee review. If not reviewed by a council subcommittee, please explain why not.

## Bid Response Summary

**Bid Number** ITB 6095-24  
**Bid Title** Butterfly Valves - Annual Value Blanket  
**Due Date** Monday, April 29, 2024 1:00:00 PM [(UTC-08:00) Pacific Time (US & Canada)]  
**Bid Status** Closed to Bidding  
**Company** Consolidated Supply Co.  
**Submitted By** Levi Martin - Monday, April 29, 2024 12:07:08 PM [(UTC-08:00) Pacific Time (US & Canada)]  
 levi.martin@consolidatedsupply.com 509-891-9911

### Comments

### Question Responses

Group	Reference Number	Question	Response
Contact			
	1.	Please indicate the appropriate point of contact (including phone number and email) regarding this quote and placement of order if awarded. If these actions will not be managed by the same person, please explicitly specify all relevant contacts.	LEVI MARTIN 509-891-9911 SKYLER HUFFMAN (509) 215-8054
Order Placement/Approval			
	1.	Award of this business (and any annual renewals) is subject to City Council approval. Award of the initial agreement is anticipated in June 2024.	I Agree
	2.	The City reserves the right to recommend award of this business either in whole or by valve category, valve size and/or delivery timeline whichever is most advantageous to the continued efficient operation of the City. This award may be split between suppliers.	I Agree
	3.	All products in a category must be quoted in order to be eligible for award.	I Agree
Value Blanket Terms			
	1.	This product shall be awarded on a one (1) year value blanket order with the option for annual renewals at mutual consent up to a total term of five (5) years. The quantities provided represent an annual usage estimate and payment shall be made only for release orders placed, received, and accepted.	I Agree
	2.	Product will be ordered off the value blanket on an as-needed basis with no guarantee of quantities.	I Agree



3.	Pricing as quoted shall be firm for placement of orders through the third quarter of 2024. Thereafter, pricing shall be provided by the supplier on a quarterly basis, firm for any orders placed through the end of that quarter, subject to City acceptance. Price increases requested by the supplier shall be accompanied with sufficient justification from the product manufacturer. During the contract period and any renewals thereof, price decreases at the manufacturer's and wholesaler's levels shall be reflected in a price reduction to the City retroactive to the supplier's effective date. The supplier may request cost increases only upon quarterly provision of pricing or upon the City's invitation for annual renewal. The supplier's prices shall otherwise remain firm throughout the contract period with no provision for increases unless specific provisions are proposed and agreed upon.	I Agree
4.	The City reserves the right to inquire at any time for sufficient justification of the supplier's current pricing.	I Agree
Product - Import		
1.	The following brands are acceptable: Val-Matic, AVK	I Agree
2.	All product shall be rubber seated and shall meet all requirements of the most recent edition of AWWA-C504 and shall be certified to NFS/ANSI 61, Class 150B or 250B as specified on the 'Pricing' tab.	I Agree
3.	All product shall be suitable for direct burial.	I Agree
4.	Valve shafts shall be constructed of ASTM A276 Type 304 or Type 431 stainless steel. Shaft seals shall be standard "O-Ring" design or V-type and shall be replaceable without removal of the valve from the line or the shaft from the valve.	I Agree
5.	The valve mating seat shall be constructed of ASTM A276 Type 304 stainless steel. Rubber seats shall be mechanically secured to the disk with a Type 316 Stainless Steel body seat ring or shall be a fully vulcanized rubber lining of the interior valve body, covering the entire water traveling surface. Seat ring bolts/screws must be Type 304 or Type 316 stainless steel. Disc mounted rubber seats of valves shall be of a design that permits adjustment or replacement in the field.	I Agree
6.	Manual valve actuators shall be of the traveling nut or worm gear type, sealed, gasketed, and permanently lubricated for buried service. Valve actuators shall be constructed and sized to the standard of the valve manufacturer to withstand all anticipated operating torque. Valve stems shall have a 2" square wrench nut, painted red with an arrow showing clockwise opening direction. Valve shall open in a clockwise direction of the nut (OPEN RIGHT).	I Agree
7.	The inside and outside of all valves shall be coated with epoxy, or fully vulcanized rubber lining of the interior valve body, covering the entire water traveling surface, meeting requirements of ANSI/AWWA C550 specifications.	I Agree

8.	Bidder shall include an affidavit of compliance stating that the valves bid fully comply with the latest revision of AWWA C504 standards.	BFV C504 compliance (002).pdf
9.	Valves must be tested to 150 PSI in both directions with actuator in place, and the actuator stops adjusted. The minimum test duration shall be ten (10) minutes and shall be drip/drop-tight.	I Agree
10.	Domestic product may be quoted for the import category; all product must meet noted specifications and shall be evaluated for award according to pricing competitiveness.	I Agree
11.	All product must ship with a complete, signed Manufacturer's Certificate of Compliance (MCC) compliant with the MCC Check List on the 'Documents' tab. To be considered compliant, all answers on the checklist must be 'yes' except #2 and #12 which do not apply. To verify familiarity with the form and acceptance of this requirement, upload a sample MCC (not the completed checklist) here which may be evaluated for compliance with the checklist. Failure to provide a compliant sample MCC may be grounds to deem a submission 'non-responsive' and, therefore, ineligible for award.	MCC SAMPLE.pdf
12.	Certification: Separate certification letters must be provided for each Butterfly Valve, with an identification tag system in use, which will identify the specific valve by serial number referred to in each letter. The letters will certify that each valve has successfully passed required performance, leakage, and hydrostatic testing.	I Agree
13.	All import product quoted shall be delivered within the following number of business days ARO:	150
13.1	Any additional explanation in regard to timeline	16"-24" - 24-28 WEEKS 30" AND LARGER - 28-30 WEEKS ORDERS UNDER \$20000 WILL INCUR FREIGHT COSTS
Product - Domestic		
1.	All requirements for import product shall apply to domestic product, unless superseded by the following requirements.	I Agree
2.	Domestic specified valves shall be Class 150B or 250B as specified and product must comply with United States Code, Title 23, Ch. 3, Sec. 313 – Buy America.	I Agree

3.	<p>Locate the Certification of Materials Origin (CMO) form on the 'Documents' tab and review. All domestic product must ship with a complete, signed CMO form verifying without exception that no products contain foreign-made materials. To verify familiarity with the form and acceptance of this requirement, upload a copy here with the name of your company in every modifiable field except the check boxes. Check the first box stating "The materials covered by this certification are American-Made with all manufacturing processing entirely within the United States of America." No signature is required. Failure to provide a CMO compliant with these directions may be grounds to deem a submission 'non-responsive' and, therefore, ineligible for award.</p>	Certificate of Materials Origin (CMO) (3).pdf
4.	<p>Bidder shall include an affidavit of compliance stating that the valves bid fully comply with the United states Code, Title 23, Ch. 3, Sec. 313 - Buy America.</p>	VALMATIC AIS VS BUY AMERICA COMPLIANCE.pdf
5.	<p>The City will accept actuators unassembled into the rest of the valve to meet the requirements for domestic product on this bid, but actuators must be delivered at the same time as the rest of the valve assembly. No other deviations from complete assembly shall be permitted.</p>	I Agree
6.	<p>All domestic product quoted shall be delivered within the following number of business days ARO:</p>	210
6.1	<p>Any additional explanation in regard to timeline.</p>	ORDERS UNDER \$20000 WILL INCUR FREIGHT COSTS
Delivery		
1.	<p>All freight expenses shall be the responsibility of the winning supplier. Unit pricing on this quote is understood to include delivery to the FOB point.</p>	I Agree
2.	<p>All product shall be ordered/delivered FOB: Destination to 914 E. North Foothills Drive, Spokane, WA 99207.</p>	I Agree
3	<p>Partial deliveries shall be accepted and any delivery delays must be communicated to the City employee who placed the order *before* the anticipated delivery date. Supplier is responsible for ensuring all deliveries meet promised timelines and for any resulting expenses, such as expedited freight costs.</p>	Acknowledged and Agreed
4.	<p>Separate certification letters must be provided for each product upon delivery, with an identification tag system in use, which will identify the specific valve by serial number referred to in each letter. Tags must be permanently affixed to valves at time of delivery. The letters will certify that each valve has successfully passed required performance, leakage, and hydrostatic testing. The letter will clearly indicate the serial number corresponding to the permanent marking on each product. Certification letters may be provided either in hard copy with shipment packing lists or in advance of delivery by electronic mail.</p>	I Agree

5.	All shipments of product shall be accompanied by a Manufacturer's Certificate of Compliance (MCC) either in hard copy with shipment packing lists or in advance of delivery by electronic mail.	I Agree
6.	All shipments of domestic product shall be accompanied by a Certificate of Materials Origin (CMO) either in hard copy with shipment packing lists or electronically in advance of delivery by electronic mail.	I Agree
7.	Shipments which arrive on the City's dock without complete documentation (serialized testing certifications, MCC, and CMO as applicable) may be refused for delivery acceptance at the supplier's expense. In the event of refusal, supplier remains fully liable to fulfill the order in accordance with the original terms and conditions.	I Agree
Payment Terms		
1.	Payment shall be made via direct deposit/ACH (except as provided by state law) according to net30 terms after receipt of goods ordered. A completed ACH application is required before a City order will be issued. If the City objects to all or any portion of an invoice, it shall notify the supplier and reserve the right to pay only that portion of the invoice not in dispute. In that event, all parties shall immediate make every effort to settle the disputed amount.	I Agree
Sales Tax		
1.	The City of Spokane is not a tax exempt entity and is therefore obligated to pay sales tax under Washington State law. Sales tax should not be included in respondent's pricing. All submissions shall be tabulated with the applicable sales tax rate whether that tax shall be charged through the supplier or paid by the City as use tax.	I Agree
Business Registration Requirement		
1.	Section 8.01.070 of the Spokane Municipal Code states that no person may engage in business with the City without first having obtained and being the holder of a valid annual business registration or temporary business registration as provided in this chapter. The supplier shall be responsible for contacting the State of Washington Business License Services at <a href="http://bls.dor.wa.gov">http://bls.dor.wa.gov</a> or 1-800-451-7985 to obtain a business registration. If the supplier does not believe it is required to obtain a business registration, it may contact the City's Taxes and Licenses Division at 509-625-6070 to request an exemption status determination.	I Agree
2.	Supplier's Business Registration No.	409023243
Polychlorinated Biphenyls (PCBs)		

1.	In accordance with SMC 7.06.172(A), supplier certifies that the products quoted and to be supplied (to include product packaging) do not contain polychlorinated biphenyls (PCBs). Moreover and consistent with SMC 7.06.172(B), the City of Spokane, at its sole discretion, may require (at no cost to the City) the apparent successful respondent to provide testing data (prior to contract execution or issue of purchase order) from an accredited laboratory or testing facility documenting the proposed products and or product packaging polychlorinated biphenyl levels.	Acknowledged and Agreed
2.	As far as you know, has this product type been tested for PCBs by a WA State accredited lab using EPA Method 1668c (or equivalent as updated)?	No
3.	If so, were PCBs found at a measurable level?	No
4.	As far as you know, has this actual product been tested for PCBs by a WA State accredited lab using EPA Method 1668 (or equivalent as updated)?	No
5.	If so, note from whom the results can be obtained.	
6.	Do you have reason to believe the product contains measurable levels of PCBs?	No
7.	Do you have reason to believe the product packaging contains measurable levels of PCBs?	No
Terms & Conditions		
1.	Submission of a response to this request constitutes acceptance of the Terms & Conditions so named in the 'Documents' tab.	I Agree

### Pricing Responses

Group	Reference Number	Description	Type	Unit Of Measure	Quantity	Unit Price	Ext Base Price	Comment	Make/Model
Product - Import - Class 150B									
	City #V5243-16	16" MJ x MJ - Class 150B	Base	Each	1.00	\$3,198.94	\$3,198.94		VALMATIC 2100 SERIES
	City #V5243-18	18" MJ x MJ - Class 150B	Base	Each	1.00	\$3,457.45	\$3,457.45		VALMATIC 2100 SERIES
	City #V5243-24	24" MJ x MJ - Class 150B	Base	Each	4.00	\$5,792.35	\$23,169.40		VALMATIC 2100 SERIES
	City #V5243-30	30" MJ x MJ - Class 150B	Base	Each	1.00	\$14,153.96	\$14,153.96		VALMATIC 2100 SERIES
	City #V5243-36	36" MJ x MJ - Class 150B	Base	Each	1.00	\$17,389.36	\$17,389.36		VALMATIC 2100 SERIES

	City #V5243-42	42" MJ x MJ - Class 150B	Base	Each	1.00	\$22,911.70	\$22,911.70	VALMATIC 2100 SERIES
	City #V5243-48	48" MJ x MJ - Class 150B	Base	Each	1.00	\$31,394.68	\$31,394.68	VALMATIC 2100 SERIES
Product - Import - Class 250B								
	City #V5243-16	16" MJ x MJ - Class 250B	Base	Each	1.00	\$3,925.53	\$3,925.53	VALMATIC 2300 SERIES
	City #V5243-18	18" MJ x MJ - Class 250B	Base	Each	1.00	\$4,835.11	\$4,835.11	VALMATIC 2300 SERIES
	City #V5243-24	24" MJ x MJ - Class 250B	Base	Each	6.00	\$6,737.23	\$40,423.38	VALMATIC 2300 SERIES
	City #V5243-30	30" MJ x MJ - Class 250B	Base	Each	1.00	\$14,998.94	\$14,998.94	VALMATIC 2300 SERIES
	City #V5243-36	36" MJ x MJ - Class 250B	Base	Each	1.00	\$19,360.64	\$19,360.64	VALMATIC 2300 SERIES
	City #V5243-42	42" MJ x MJ - Class 250B	Base	Each	1.00	\$32,285.11	\$32,285.11	VALMATIC 2300 SERIES
	City #V5243-48	48" MJ x MJ - Class 250B	Base	Each	1.00	\$37,318.63	\$37,318.63	VALMATIC 2300 SERIES
Product - Domestic - Class 150B								
	City #V5243-16-D	16" MJ x MJ - Domestic - Class 150B	Base	Each	1.00	\$11,778.32	\$11,778.32	VALMATIC 2100XD - AIS COMPLIANT
	City #V5243-18-D	18" MJ x MJ - Domestic - Class 150B	Base	Each	6.00	\$12,681.92	\$76,091.52	VALMATIC 2100XD - AIS COMPLIANT
	City #V5243-24-D	24" MJ x MJ - Domestic - Class 150B	Base	Each	2.00	\$18,824.28	\$37,648.56	VALMATIC 2100XD - AIS COMPLIANT
	City #V5243-30-D	30" MJ x MJ - Domestic - Class 150B	Base	Each	6.00	\$38,585.11	\$231,510.66	VALMATIC 2100XD - AIS COMPLIANT

City #V5243- 36-D	36" MJ x MJ - Domestic - Class 150B	Base	Each	1.00	\$44,905.32	\$44,905.32	VALMATIC 2100XD - AIS COMPLIANT
City #V5243- 42-D	42" MJ x MJ - Domestic - Class 150B	Base	Each	1.00	\$55,744.68	\$55,744.68	VALMATIC 2100XD - AIS COMPLIANT
City #V5243- 48-D	48" MJ x MJ - Domestic - Class 150B	Base	Each	1.00	\$72,590.43	\$72,590.43	VALMATIC 2100XD - AIS COMPLIANT
Product - Domestic - Class 250B							
City #V5243- 16-D	16" MJ x MJ - Domestic - Class 250B	Base	Each	1.00	\$10,809.57	\$10,809.57	VALMATIC 2300XD - AIS COMPLIANT
City #V5243- 18-D	18" MJ x MJ - Domestic - Class 250B	Base	Each	1.00	\$13,165.96	\$13,165.96	VALMATIC 2300XD - AIS COMPLIANT
City #V5243- 24-D	24" MJ x MJ - Domestic - Class 250B	Base	Each	1.00	\$20,509.74	\$20,509.74	VALMATIC 2300XD - AIS COMPLIANT
City #V5243- 30-D	30" MJ x MJ - Domestic - Class 250B	Base	Each	1.00	\$39,872.34	\$39,872.34	VALMATIC 2300XD - AIS COMPLIANT
City #V5243- 36-D	36" MJ x MJ - Domestic - Class 250B	Base	Each	1.00	\$50,051.06	\$50,051.06	VALMATIC 2300XD - AIS COMPLIANT
City #V5243- 42-D	42" MJ x MJ - Domestic - Class 250B	Base	Each	1.00	\$58,848.94	\$58,848.94	VALMATIC 2300XD - AIS COMPLIANT
City #V5243- 48-D	48" MJ x MJ - Domestic - Class 250B	Base	Each	1.00	\$76,436.17	\$76,436.17	VALMATIC 2300XD - AIS COMPLIANT
<b>Total Base Bid</b>	\$1,068,786.10						

**ITB #6095-24 BUTTERFLY VALVES - ANNUAL \**  
**BID TABULATION**

Reference Number	Description	Type	UOM	Quantity	Extended Estimate
Product - Import - Class 150B					
City #V5243-16	16" MJ x MJ - Class 150B	Base	Each	1	
City #V5243-18	18" MJ x MJ - Class 150B	Base	Each	1	
City #V5243-24	24" MJ x MJ - Class 150B	Base	Each	4	
City #V5243-30	30" MJ x MJ - Class 150B	Base	Each	1	
City #V5243-36	36" MJ x MJ - Class 150B	Base	Each	1	
City #V5243-42	42" MJ x MJ - Class 150B	Base	Each	1	
City #V5243-48	48" MJ x MJ - Class 150B	Base	Each	1	
					ARO
Product - Import - Class 250B					
City #V5243-16	16" MJ x MJ - Class 250B	Base	Each	1	
City #V5243-18	18" MJ x MJ - Class 250B	Base	Each	1	
City #V5243-24	24" MJ x MJ - Class 250B	Base	Each	6	
City #V5243-30	30" MJ x MJ - Class 250B	Base	Each	1	
City #V5243-36	36" MJ x MJ - Class 250B	Base	Each	1	
City #V5243-42	42" MJ x MJ - Class 250B	Base	Each	1	
City #V5243-48	48" MJ x MJ - Class 250B	Base	Each	1	
					ARO



Product - Domestic - Class 150B					
City #V5243-16-D	16" MJ x MJ - Domestic - Class 150B	Base	Each	1	
City #V5243-18-D	18" MJ x MJ - Domestic - Class 150B	Base	Each	6	
City #V5243-24-D	24" MJ x MJ - Domestic - Class 150B	Base	Each	2	
City #V5243-30-D	30" MJ x MJ - Domestic - Class 150B	Base	Each	6	
City #V5243-36-D	36" MJ x MJ - Domestic - Class 150B	Base	Each	1	
City #V5243-42-D	42" MJ x MJ - Domestic - Class 150B	Base	Each	1	
City #V5243-48-D	48" MJ x MJ - Domestic - Class 150B	Base	Each	1	
					ARO
Product - Domestic - Class 250B					
City #V5243-16-D	16" MJ x MJ - Domestic - Class 250B	Base	Each	1	
City #V5243-18-D	18" MJ x MJ - Domestic - Class 250B	Base	Each	1	
City #V5243-24-D	24" MJ x MJ - Domestic - Class 250B	Base	Each	1	
City #V5243-30-D	30" MJ x MJ - Domestic - Class 250B	Base	Each	1	
City #V5243-36-D	36" MJ x MJ - Domestic - Class 250B	Base	Each	1	
City #V5243-42-D	42" MJ x MJ - Domestic - Class 250B	Base	Each	1	
City #V5243-48-D	48" MJ x MJ - Domestic - Class 250B	Base	Each	1	
					ARO
Total Extended					

# VALUE BLANKET

H D FOWLER CO	American AVK	Consolidated Supply Co.
\$3,540.00	\$3,714.48	\$3,198.94
\$3,830.00	\$4,173.84	\$3,457.45
\$25,360.00	\$31,173.12	\$23,169.40
\$15,105.00	\$14,723.28	\$14,153.96
\$18,590.00	\$17,859.60	\$17,389.36
\$22,450.00	\$27,660.60	\$22,911.70
\$30,740.00	\$35,675.64	\$31,394.68
\$119,615.00	\$134,980.56	\$115,675.49
160	115	150
\$4,300.00	\$3,714.48	\$3,925.53
\$5,250.00	\$4,173.84	\$4,835.11
\$43,800.00	\$46,759.68	\$40,423.38
\$15,960.00	\$14,723.28	\$14,998.94
\$20,580.00	\$17,859.60	\$19,360.64
\$31,620.00	\$27,660.60	\$32,285.11
\$36,540.00	\$35,675.64	\$37,318.63
\$158,050.00	\$150,567.12	\$153,147.34
160	115	150

		\$11,778.32
		\$76,091.52
		\$37,648.56
		\$231,510.66
		\$44,905.32
		\$55,744.68
		\$72,590.43
\$0.00	\$0.00	\$530,269.49
9999	0	210
		\$10,809.57
		\$13,165.96
		\$20,509.74
		\$39,872.34
		\$50,051.06
		\$58,848.94
		\$76,436.17
\$0.00	\$0.00	\$269,693.78
9999	0	210
\$277,665.00	\$285,547.68	\$1,068,786.10



**Agenda Sheet for City Council:**

**Committee:** PIES **Date:** 05/20/2024

**Committee Agenda type:** Consent

**Date Rec'd**

5/20/2024

**Clerk's File #**

OPR 2024-0459

**Cross Ref #**

**Project #**

**Council Meeting Date:** 06/10/2024

**Submitting Dept**

WATER & HYDROELECTRIC SERVICES

**Bid #**

ITB 6095-24

**Contact Name/Phone**

LOREN SEARL 625-7821

**Requisition #**

VB

**Contact E-Mail**

LSEARL@SPOKANECITY.ORG

**Agenda Item Type**

Purchase w/o Contract

**Council Sponsor(s)**

BWILKERSON JBINGLE KKLITZKE

**Agenda Item Name**

4100 APPROVAL OF VALUE BLANKET ORDER FOR BUTTERFLY VALVES

**Agenda Wording**

Five (5) year value blanket with American AVK (Minden, NV) for purchase of imported and domestic butterfly valves on an as-needed basis. Annual spend is estimated at \$300,000.00 including tax.

**Summary (Background)**

Invitation to Bid 6095-24 was opened on 4-10-24 for the annual supply of butterfly valves on an "as needed" basis. Bids were accepted until 4-29-24. Three responses were received with American AVK came in as the shortest delivery timeline and slightly higher cost.

Lease? NO Grant related? NO Public Works? NO

**Fiscal Impact**

Approved in Current Year Budget? YES

Total Cost \$ 1,500,000.00

Current Year Cost \$ 300,000.00

Subsequent Year(s) Cost \$ 300,000.00

**Narrative**

Five (5) year value blanket with no renewal options. Annual spend estimated at \$300,000.00 including tax.

**Amount**

**Budget Account**

Expense \$ 1,500,000.00

# 4100-42440-94340-56595-99999

Select \$

#

Select \$

#

Select \$

#

\$

#

\$

#



# Continuation of Wording, Summary, Approvals, and Distribution

## Agenda Wording

## Summary (Background)

### **Approvals**

<b><u>Dept Head</u></b>	SEARL, LOREN
<b><u>Division Director</u></b>	FEIST, MARLENE
<b><u>Accounting Manager</u></b>	ALBIN-MOORE, ANGELA
<b><u>Legal</u></b>	HARRINGTON,
<b><u>For the Mayor</u></b>	PICCOLO, MIKE

### **Additional Approvals**

<b><u>PURCHASING</u></b>	PRINCE, THEA

### **Distribution List**

Andrew Sirak - asirak@avkus.com	nrussell@spokanecity.org
Loren Searl - lsearl@spokanecity.org	rrpenaluna@spokanecity.org
tlester@spokanecity.org	

## Committee Agenda Sheet

### Public Infrastructure, Environment & Sustainability Committee

<b>Committee Date</b>	5-20-24
<b>Submitting Department</b>	Water & Hydroelectric Services
<b>Contact Name</b>	Loren Searl
<b>Contact Email &amp; Phone</b>	<a href="mailto:lsearl@spokanecity.org">lsearl@spokanecity.org</a> 509-625-7821
<b>Council Sponsor(s)</b>	Wilkerson, Bingle, Klitzke
<b>Select Agenda Item Type</b>	<input checked="" type="checkbox"/> Consent <input type="checkbox"/> Discussion    Time Requested: Purchase w/o Contract
<b>Agenda Item Name</b>	4100 Approval of Value Blanket order for Butterfly Valves
<b>Proposed Council Action</b>	<input type="checkbox"/> Approval to proceed to Legislative Agenda <input type="checkbox"/> Information Only
<b>Summary (Background)</b>	Request for Quotes 6095-24 was opened on 4-10-24 for the annual supply of butterfly valves on an "as needed" basis. Bids were accepted until 4-29-24. Three responses were received with American AVK came in as the shortest delivery timeline and slightly higher cost.
*use the Fiscal Impact box below for relevant financial information	
<p><b>Fiscal Impact</b></p> <p><b>Approved in current year budget?</b>    <input checked="" type="checkbox"/> Yes    <input type="checkbox"/> No    <input type="checkbox"/> N/A</p> <p>Total Cost: <u>1,500,000.00</u></p> <p style="padding-left: 20px;">Current year cost: 300,000.00</p> <p style="padding-left: 20px;">Subsequent year(s) cost: 300,000.00</p> <p><b>Narrative:</b> Please provide financial due diligence review, as applicable, such as number and type of positions, grant match requirements, summary type details (personnel, maintenance and supplies, capital, revenue), impact on rates, fees, or future shared revenue</p> <p><b>Funding Source</b>    <input type="checkbox"/> One-time    <input type="checkbox"/> Recurring    <input type="checkbox"/> N/A</p> <p>Specify funding source: Select Funding Source*</p> <p>Is this funding source sustainable for future years, months, etc? <a href="#">Click or tap here to enter text.</a></p> <p><b>Expense Occurrence</b>    <input type="checkbox"/> One-time    <input type="checkbox"/> Recurring    <input type="checkbox"/> N/A</p> <p>Other budget impacts: (revenue generating, match requirements, etc.)</p>	
<p><b>Operations Impacts (If N/A, please give a brief description as to why)</b></p> <ul style="list-style-type: none"> <li>• What impacts would the proposal have on historically excluded communities? Public works services and projects are designed to serve all citizens and businesses. We strive to offer a consistent level of service to all, to distribute public investment throughout the community and to respond to gaps in services identified in various City plans. We recognize the need to maintain affordability and predictability for utility customers and we are committed to delivering work that is</li> </ul>	

both financially and environmentally responsible. This project is specifically designed to assist low-income residents get caught up on their City utility bills.

- How will data be collected, analyzed, and reported concerning the effect of the program/policy by racial, ethnic, gender identity, national origin, income level, disability, sexual orientation, or other existing disparities?

N/A

- How will data be collected regarding the effectiveness of this program, policy, or product to ensure it is the right solution?

Public Works follows the City's established procurement and public works bidding regulations and policies to bring items forward, and then uses contract management best practices to ensure desired outcomes and regulatory compliance.

- Describe how this proposal aligns with current City Policies, including the Comprehensive Plan, Sustainability Action Plan, Capital Improvement Program, Neighborhood Master Plans, Council Resolutions, and others?

This work is consistent with annual budget strategies to limit costs and approved projects in the 6-year CIP.

### **Council Subcommittee Review**

- Please provide a summary of council subcommittee review. If not reviewed by a council subcommittee, please explain why not.

## Bid Response Summary

**Bid Number** ITB 6095-24  
**Bid Title** Butterfly Valves - Annual Value Blanket  
**Due Date** Monday, April 29, 2024 1:00:00 PM [(UTC-08:00) Pacific Time (US & Canada)]  
**Bid Status** Closed to Bidding  
**Company** American AVK  
**Submitted By** Andrew Sirak - Friday, April 26, 2024 12:27:57 PM [(UTC-08:00) Pacific Time (US & Canada)]  
 asirak@avkus.com

**Comments**

**Question Responses**

Group	Reference Number	Question	Response
Contact			
	1.	Please indicate the appropriate point of contact (including phone number and email) regarding this quote and placement of order if awarded. If these actions will not be managed by the same person, please explicitly specify all relevant contacts.	Andrew Sirak; 503-716-6557; asirak@avkus.com
Order Placement/Approval			
	1.	Award of this business (and any annual renewals) is subject to City Council approval. Award of the initial agreement is anticipated in June 2024.	I Agree
	2.	The City reserves the right to recommend award of this business either in whole or by valve category, valve size and/or delivery timeline whichever is most advantageous to the continued efficient operation of the City. This award may be split between suppliers.	I Agree
	3.	All products in a category must be quoted in order to be eligible for award.	I Agree
Value Blanket Terms			
	1.	This product shall be awarded on a one (1) year value blanket order with the option for annual renewals at mutual consent up to a total term of five (5) years. The quantities provided represent an annual usage estimate and payment shall be made only for release orders placed, received, and accepted.	I Agree
	2.	Product will be ordered off the value blanket on an as-needed basis with no guarantee of quantities.	I Agree



3.	Pricing as quoted shall be firm for placement of orders through the third quarter of 2024. Thereafter, pricing shall be provided by the supplier on a quarterly basis, firm for any orders placed through the end of that quarter, subject to City acceptance. Price increases requested by the supplier shall be accompanied with sufficient justification from the product manufacturer. During the contract period and any renewals thereof, price decreases at the manufacturer's and wholesaler's levels shall be reflected in a price reduction to the City retroactive to the supplier's effective date. The supplier may request cost increases only upon quarterly provision of pricing or upon the City's invitation for annual renewal. The supplier's prices shall otherwise remain firm throughout the contract period with no provision for increases unless specific provisions are proposed and agreed upon.	I Agree
4.	The City reserves the right to inquire at any time for sufficient justification of the supplier's current pricing.	I Agree
Product - Import		
1.	The following brands are acceptable: Val-Matic, AVK	I Agree
2.	All product shall be rubber seated and shall meet all requirements of the most recent edition of AWWA-C504 and shall be certified to NFS/ANSI 61, Class 150B or 250B as specified on the 'Pricing' tab.	I Agree
3.	All product shall be suitable for direct burial.	I Agree
4.	Valve shafts shall be constructed of ASTM A276 Type 304 or Type 431 stainless steel. Shaft seals shall be standard "O-Ring" design or V-type and shall be replaceable without removal of the valve from the line or the shaft from the valve.	I Agree
5.	The valve mating seat shall be constructed of ASTM A276 Type 304 stainless steel. Rubber seats shall be mechanically secured to the disk with a Type 316 Stainless Steel body seat ring or shall be a fully vulcanized rubber lining of the interior valve body, covering the entire water traveling surface. Seat ring bolts/screws must be Type 304 or Type 316 stainless steel. Disc mounted rubber seats of valves shall be of a design that permits adjustment or replacement in the field.	I Agree
6.	Manual valve actuators shall be of the traveling nut or worm gear type, sealed, gasketed, and permanently lubricated for buried service. Valve actuators shall be constructed and sized to the standard of the valve manufacturer to withstand all anticipated operating torque. Valve stems shall have a 2" square wrench nut, painted red with an arrow showing clockwise opening direction. Valve shall open in a clockwise direction of the nut (OPEN RIGHT).	I Agree
7.	The inside and outside of all valves shall be coated with epoxy, or fully vulcanized rubber lining of the interior valve body, covering the entire water traveling surface, meeting requirements of ANSI/AWWA C550 specifications.	I Agree

8.	Bidder shall include an affidavit of compliance stating that the valves bid fully comply with the latest revision of AWWA C504 standards.	AVK BFV Certificates of Compliance and Cutsheets.zip
9.	Valves must be tested to 150 PSI in both directions with actuator in place, and the actuator stops adjusted. The minimum test duration shall be ten (10) minutes and shall be drip/drop-tight.	I Agree
10.	Domestic product may be quoted for the import category; all product must meet noted specifications and shall be evaluated for award according to pricing competitiveness.	I Agree
11.	All product must ship with a complete, signed Manufacturer's Certificate of Compliance (MCC) compliant with the MCC Check List on the 'Documents' tab. To be considered compliant, all answers on the checklist must be 'yes' except #2 and #12 which do not apply. To verify familiarity with the form and acceptance of this requirement, upload a sample MCC (not the completed checklist) here which may be evaluated for compliance with the checklist. Failure to provide a compliant sample MCC may be grounds to deem a submission 'non-responsive' and, therefore, ineligible for award.	MCC Spokane BFV.pdf
12.	Certification: Separate certification letters must be provided for each Butterfly Valve, with an identification tag system in use, which will identify the specific valve by serial number referred to in each letter. The letters will certify that each valve has successfully passed required performance, leakage, and hydrostatic testing.	I Agree
13.	All import product quoted shall be delivered within the following number of business days ARO:	115
13.1	Any additional explanation in regard to timeline	Product can be expected to ship from Minden, NV 14-16 weeks from placement of PO.
Product - Domestic		
1.	All requirements for import product shall apply to domestic product, unless superseded by the following requirements.	I do not Agree
2.	Domestic specified valves shall be Class 150B or 250B as specified and product must comply with United States Code, Title 23, Ch. 3, Sec. 313 – Buy America.	I do not Agree

3.	<p>Locate the Certification of Materials Origin (CMO) form on the 'Documents' tab and review. All domestic product must ship with a complete, signed CMO form verifying without exception that no products contain foreign-made materials. To verify familiarity with the form and acceptance of this requirement, upload a copy here with the name of your company in every modifiable field except the check boxes. Check the first box stating "The materials covered by this certification are American-Made with all manufacturing processing entirely within the United States of America." No signature is required. Failure to provide a CMO compliant with these directions may be grounds to deem a submission 'non-responsive' and, therefore, ineligible for award.</p>	Spokane Doc.pdf
4.	<p>Bidder shall include an affidavit of compliance stating that the valves bid fully comply with the United states Code, Title 23, Ch. 3, Sec. 313 - Buy America.</p>	Spokane Doc.pdf
5.	<p>The City will accept actuators unassembled into the rest of the valve to meet the requirements for domestic product on this bid, but actuators must be delivered at the same time as the rest of the valve assembly. No other deviations from complete assembly shall be permitted.</p>	I do not Agree
6.	<p>All domestic product quoted shall be delivered within the following number of business days ARO:</p>	0
6.1	<p>Any additional explanation in regard to timeline.</p>	AVK is not bidding the domestic section of this annual bid.
Delivery		
1.	<p>All freight expenses shall be the responsibility of the winning supplier. Unit pricing on this quote is understood to include delivery to the FOB point.</p>	I Agree
2.	<p>All product shall be ordered/delivered FOB: Destination to 914 E. North Foothills Drive, Spokane, WA 99207.</p>	I Agree
3	<p>Partial deliveries shall be accepted and any delivery delays must be communicated to the City employee who placed the order *before* the anticipated delivery date. Supplier is responsible for ensuring all deliveries meet promised timelines and for any resulting expenses, such as expedited freight costs.</p>	Acknowledged and Agreed
4.	<p>Separate certification letters must be provided for each product upon delivery, with an identification tag system in use, which will identify the specific valve by serial number referred to in each letter. Tags must be permanently affixed to valves at time of delivery. The letters will certify that each valve has successfully passed required performance, leakage, and hydrostatic testing. The letter will clearly indicate the serial number corresponding to the permanent marking on each product. Certification letters may be provided either in hard copy with shipment packing lists or in advance of delivery by electronic mail.</p>	I Agree

5.	All shipments of product shall be accompanied by a Manufacturer's Certificate of Compliance (MCC) either in hard copy with shipment packing lists or in advance of delivery by electronic mail.	I Agree
6.	All shipments of domestic product shall be accompanied by a Certificate of Materials Origin (CMO) either in hard copy with shipment packing lists or electronically in advance of delivery by electronic mail.	I Agree
7.	Shipments which arrive on the City's dock without complete documentation (serialized testing certifications, MCC, and CMO as applicable) may be refused for delivery acceptance at the supplier's expense. In the event of refusal, supplier remains fully liable to fulfill the order in accordance with the original terms and conditions.	I Agree
Payment Terms		
1.	Payment shall be made via direct deposit/ACH (except as provided by state law) according to net30 terms after receipt of goods ordered. A completed ACH application is required before a City order will be issued. If the City objects to all or any portion of an invoice, it shall notify the supplier and reserve the right to pay only that portion of the invoice not in dispute. In that event, all parties shall immediately make every effort to settle the disputed amount.	I Agree
Sales Tax		
1.	The City of Spokane is not a tax exempt entity and is therefore obligated to pay sales tax under Washington State law. Sales tax should not be included in respondent's pricing. All submissions shall be tabulated with the applicable sales tax rate whether that tax shall be charged through the supplier or paid by the City as use tax.	I Agree
Business Registration Requirement		
1.	Section 8.01.070 of the Spokane Municipal Code states that no person may engage in business with the City without first having obtained and being the holder of a valid annual business registration or temporary business registration as provided in this chapter. The supplier shall be responsible for contacting the State of Washington Business License Services at <a href="http://bls.dor.wa.gov">http://bls.dor.wa.gov</a> or 1-800-451-7985 to obtain a business registration. If the supplier does not believe it is required to obtain a business registration, it may contact the City's Taxes and Licenses Division at 509-625-6070 to request an exemption status determination.	I Agree
2.	Supplier's Business Registration No.	6042773
Polychlorinated Biphenyls (PCBs)		

1.	In accordance with SMC 7.06.172(A), supplier certifies that the products quoted and to be supplied (to include product packaging) do not contain polychlorinated biphenyls (PCBs). Moreover and consistent with SMC 7.06.172(B), the City of Spokane, at its sole discretion, may require (at no cost to the City) the apparent successful respondent to provide testing data (prior to contract execution or issue of purchase order) from an accredited laboratory or testing facility documenting the proposed products and or product packaging polychlorinated biphenyl levels.	Acknowledged and Agreed
2.	As far as you know, has this product type been tested for PCBs by a WA State accredited lab using EPA Method 1668c (or equivalent as updated)?	No
3.	If so, were PCBs found at a measurable level?	No
4.	As far as you know, has this actual product been tested for PCBs by a WA State accredited lab using EPA Method 1668 (or equivalent as updated)?	No
5.	If so, note from whom the results can be obtained.	
6.	Do you have reason to believe the product contains measurable levels of PCBs?	No
7.	Do you have reason to believe the product packaging contains measurable levels of PCBs?	No
Terms & Conditions		
1.	Submission of a response to this request constitutes acceptance of the Terms & Conditions so named in the 'Documents' tab.	I Agree

### Pricing Responses

Group	Reference Number	Description	Type	Unit Of Measure	Quantity	Unit Price	Ext Base Price	Comment	Make/Model
Product - Import - Class 150B									
	City #V5243-16	16" MJ x MJ - Class 150B	Base	Each	1.00	\$3,714.48	\$3,714.48		S816
	City #V5243-18	18" MJ x MJ - Class 150B	Base	Each	1.00	\$4,173.84	\$4,173.84		S816
	City #V5243-24	24" MJ x MJ - Class 150B	Base	Each	4.00	\$7,793.28	\$31,173.12		S816
	City #V5243-30	30" MJ x MJ - Class 150B	Base	Each	1.00	\$14,723.28	\$14,723.28		S766
	City #V5243-36	36" MJ x MJ - Class 150B	Base	Each	1.00	\$17,859.60	\$17,859.60		S766

	City #V5243- 42	42" MJ x MJ - Class 150B	Base	Each	1.00	\$27,660.60	\$27,660.60	S766
	City #V5243- 48	48" MJ x MJ - Class 150B	Base	Each	1.00	\$35,675.64	\$35,675.64	S766
Product - Import - Class 250B								
	City #V5243- 16	16" MJ x MJ - Class 250B	Base	Each	1.00	\$3,714.48	\$3,714.48	S816
	City #V5243- 18	18" MJ x MJ - Class 250B	Base	Each	1.00	\$4,173.84	\$4,173.84	S816
	City #V5243- 24	24" MJ x MJ - Class 250B	Base	Each	6.00	\$7,793.28	\$46,759.68	S816
	City #V5243- 30	30" MJ x MJ - Class 250B	Base	Each	1.00	\$14,723.28	\$14,723.28	S766
	City #V5243- 36	36" MJ x MJ - Class 250B	Base	Each	1.00	\$17,859.60	\$17,859.60	S766
	City #V5243- 42	42" MJ x MJ - Class 250B	Base	Each	1.00	\$27,660.60	\$27,660.60	S766
	City #V5243- 48	48" MJ x MJ - Class 250B	Base	Each	1.00	\$35,675.64	\$35,675.64	S766
Product - Domestic - Class 150B								
	City #V5243- 16-D	16" MJ x MJ - Domestic - Class 150B	Base	Each	1.00			
	City #V5243- 18-D	18" MJ x MJ - Domestic - Class 150B	Base	Each	6.00			
	City #V5243- 24-D	24" MJ x MJ - Domestic - Class 150B	Base	Each	2.00			
	City #V5243- 30-D	30" MJ x MJ - Domestic - Class 150B	Base	Each	6.00			
	City #V5243- 36-D	36" MJ x MJ - Domestic - Class 150B	Base	Each	1.00			

City #V5243- 42-D	42" MJ x MJ - Domestic - Class 150B	Base	Each	1.00
City #V5243- 48-D	48" MJ x MJ - Domestic - Class 150B	Base	Each	1.00
Product - Domestic - Class 250B				
City #V5243- 16-D	16" MJ x MJ - Domestic - Class 250B	Base	Each	1.00
City #V5243- 18-D	18" MJ x MJ - Domestic - Class 250B	Base	Each	1.00
City #V5243- 24-D	24" MJ x MJ - Domestic - Class 250B	Base	Each	1.00
City #V5243- 30-D	30" MJ x MJ - Domestic - Class 250B	Base	Each	1.00
City #V5243- 36-D	36" MJ x MJ - Domestic - Class 250B	Base	Each	1.00
City #V5243- 42-D	42" MJ x MJ - Domestic - Class 250B	Base	Each	1.00
City #V5243- 48-D	48" MJ x MJ - Domestic - Class 250B	Base	Each	1.00
<b>Total Base Bid</b>	<b>\$285,547.68</b>			

**ITB #6095-24 BUTTERFLY VALVES - ANNUAL \**  
**BID TABULATION**

Reference Number	Description	Type	UOM	Quantity	Extended Estimate
Product - Import - Class 150B					
City #V5243-16	16" MJ x MJ - Class 150B	Base	Each	1	
City #V5243-18	18" MJ x MJ - Class 150B	Base	Each	1	
City #V5243-24	24" MJ x MJ - Class 150B	Base	Each	4	
City #V5243-30	30" MJ x MJ - Class 150B	Base	Each	1	
City #V5243-36	36" MJ x MJ - Class 150B	Base	Each	1	
City #V5243-42	42" MJ x MJ - Class 150B	Base	Each	1	
City #V5243-48	48" MJ x MJ - Class 150B	Base	Each	1	
					ARO
Product - Import - Class 250B					
City #V5243-16	16" MJ x MJ - Class 250B	Base	Each	1	
City #V5243-18	18" MJ x MJ - Class 250B	Base	Each	1	
City #V5243-24	24" MJ x MJ - Class 250B	Base	Each	6	
City #V5243-30	30" MJ x MJ - Class 250B	Base	Each	1	
City #V5243-36	36" MJ x MJ - Class 250B	Base	Each	1	
City #V5243-42	42" MJ x MJ - Class 250B	Base	Each	1	
City #V5243-48	48" MJ x MJ - Class 250B	Base	Each	1	
					ARO



Product - Domestic - Class 150B					
City #V5243-16-D	16" MJ x MJ - Domestic - Class 150B	Base	Each	1	
City #V5243-18-D	18" MJ x MJ - Domestic - Class 150B	Base	Each	6	
City #V5243-24-D	24" MJ x MJ - Domestic - Class 150B	Base	Each	2	
City #V5243-30-D	30" MJ x MJ - Domestic - Class 150B	Base	Each	6	
City #V5243-36-D	36" MJ x MJ - Domestic - Class 150B	Base	Each	1	
City #V5243-42-D	42" MJ x MJ - Domestic - Class 150B	Base	Each	1	
City #V5243-48-D	48" MJ x MJ - Domestic - Class 150B	Base	Each	1	
					ARO
Product - Domestic - Class 250B					
City #V5243-16-D	16" MJ x MJ - Domestic - Class 250B	Base	Each	1	
City #V5243-18-D	18" MJ x MJ - Domestic - Class 250B	Base	Each	1	
City #V5243-24-D	24" MJ x MJ - Domestic - Class 250B	Base	Each	1	
City #V5243-30-D	30" MJ x MJ - Domestic - Class 250B	Base	Each	1	
City #V5243-36-D	36" MJ x MJ - Domestic - Class 250B	Base	Each	1	
City #V5243-42-D	42" MJ x MJ - Domestic - Class 250B	Base	Each	1	
City #V5243-48-D	48" MJ x MJ - Domestic - Class 250B	Base	Each	1	
					ARO
Total Extended					

# VALUE BLANKET

H D FOWLER CO	American AVK	Consolidated Supply Co.
\$3,540.00	\$3,714.48	\$3,198.94
\$3,830.00	\$4,173.84	\$3,457.45
\$25,360.00	\$31,173.12	\$23,169.40
\$15,105.00	\$14,723.28	\$14,153.96
\$18,590.00	\$17,859.60	\$17,389.36
\$22,450.00	\$27,660.60	\$22,911.70
\$30,740.00	\$35,675.64	\$31,394.68
\$119,615.00	\$134,980.56	\$115,675.49
160	115	150
\$4,300.00	\$3,714.48	\$3,925.53
\$5,250.00	\$4,173.84	\$4,835.11
\$43,800.00	\$46,759.68	\$40,423.38
\$15,960.00	\$14,723.28	\$14,998.94
\$20,580.00	\$17,859.60	\$19,360.64
\$31,620.00	\$27,660.60	\$32,285.11
\$36,540.00	\$35,675.64	\$37,318.63
\$158,050.00	\$150,567.12	\$153,147.34
160	115	150

		\$11,778.32
		\$76,091.52
		\$37,648.56
		\$231,510.66
		\$44,905.32
		\$55,744.68
		\$72,590.43
\$0.00	\$0.00	\$530,269.49
9999	0	210
		\$10,809.57
		\$13,165.96
		\$20,509.74
		\$39,872.34
		\$50,051.06
		\$58,848.94
		\$76,436.17
\$0.00	\$0.00	\$269,693.78
9999	0	210
\$277,665.00	\$285,547.68	\$1,068,786.10



**Agenda Sheet for City Council:**

**Committee:** PIES **Date:** 05/20/2024

**Committee Agenda type:** Consent

**Date Rec'd** 5/20/2024

**Clerk's File #** OPR 2021-0447

**Cross Ref #**

**Project #**

**Council Meeting Date:** 06/10/2024

**Submitting Dept** WATER & HYDROELECTRIC SERVICES

**Bid #** ITB 5439-21

**Contact Name/Phone** LOREN SEARL 625-7821

**Requisition #**

**Contact E-Mail** LSEARL@SPOKANECITY.ORG

**Agenda Item Type** Contract Item

**Council Sponsor(s)** BWILKERSON JBINGLE KKLITZKE

**Agenda Item Name** 4100 PAVING SERVICES – ON CALL PUBLIC WORKS MAINTENANCE

**Agenda Wording**

Contract renewal with Shamrock Paving, Inc. (Spokane, WA) For on call paving services. From 07/01/2024 thru 06/30/2025. Not to exceed \$250,000 annually excluding taxes.

**Summary (Background)**

The Water Department needs a contract to facilitate block-long asphalt repairs on a quick turn basis. ITB 5439-21 opened for bidding on 5/12/2021 and bids were accepted until 6/1/2021. Two bids were received. Award is correspondingly recommended to Shamrock Paving as the low responsive, responsible bidder. The resulting contract will be valid for three years with one optional annual renewal at mutual consent.

Lease? NO Grant related? NO Public Works? YES

**Fiscal Impact**

Approved in Current Year Budget? YES

Total Cost \$ 250,000.00

Current Year Cost \$ 250,000.00

Subsequent Year(s) Cost \$

**Narrative**

Contract renewal with Shamrock Paving, Inc. (Spokane, WA) for on-call paving services on an as-needed basis not to exceed \$250,000.00 excluding tax.

**Amount**

**Budget Account**

Expense \$ 250,000.00 # 4100-42420-34148-54809-99999

Select \$ #

Select \$ #

Select \$ #

\$ #

\$ #



## Continuation of Wording, Summary, Approvals, and Distribution

### Agenda Wording

### Summary (Background)

#### **Approvals**

##### Dept Head

SEARL, LOREN

##### Division Director

FEIST, MARLENE

##### Accounting Manager

ALBIN-MOORE, ANGELA

##### Legal

HARRINGTON,

##### For the Mayor

PICCOLO, MIKE

#### **Additional Approvals**

#### **Distribution List**

Scott Willms - scottw@shamrockpaving.us

rrpenaluna@spokanecity.org

nrussell@spokanecity.org

## Committee Agenda Sheet

### Public Infrastructure, Environment & Sustainability Committee

<b>Committee Date</b>	5-20-24
<b>Submitting Department</b>	Water & Hydroelectric Services
<b>Contact Name</b>	Loren Searl
<b>Contact Email &amp; Phone</b>	<a href="mailto:lsearl@spokanecity.org">lsearl@spokanecity.org</a> 509-625-7821
<b>Council Sponsor(s)</b>	Wilkerson, Bingle, Klitzke
<b>Select Agenda Item Type</b>	<input checked="" type="checkbox"/> Consent <input type="checkbox"/> Discussion    Time Requested: Contract Renewal
<b>Agenda Item Name</b>	4100 Paving Services – On Call Public Works Maintenance
<b>Proposed Council Action</b>	<input type="checkbox"/> Approval to proceed to Legislative Agenda <input type="checkbox"/> Information Only
<b>Summary (Background)</b>	The Water Department needs a contract to facilitate block-long asphalt repairs on a quick turn basis. ITB 5439-21 opened for bidding on 5/12/2021 and bids were accepted until 6/1/2021. Two bids were received. Award is correspondingly recommended to Shamrock Paving as the low responsive, responsible bidder. The resulting contract will be valid for three years with one optional annual renewal at mutual consent.
*use the Fiscal Impact box below for relevant financial information	
<b>Fiscal Impact</b>	
<b>Approved in current year budget?</b> <input checked="" type="checkbox"/> Yes <input type="checkbox"/> No <input type="checkbox"/> N/A Total Cost: <u>250,000.00</u> Current year cost: 250,000.00 Subsequent year(s) cost:	
<b>Narrative:</b> <u>Contract renewal with Shamrock Paving, Inc. (Spokane, WA) for on-call paving services on an as-needed basis not to exceed \$250,000.00 excluding tax.</u>	
<b>Funding Source</b> <input checked="" type="checkbox"/> One-time <input type="checkbox"/> Recurring <input type="checkbox"/> N/A Specify funding source: Select Funding Source* Is this funding source sustainable for future years, months, etc? 1 year	
<b>Expense Occurrence</b> <input checked="" type="checkbox"/> One-time <input type="checkbox"/> Recurring <input type="checkbox"/> N/A  Other budget impacts: 4100-42420-34148-54809-99999	
<b>Operations Impacts (If N/A, please give a brief description as to why)</b>	
<ul style="list-style-type: none"> <li>• What impacts would the proposal have on historically excluded communities?              Public works services and projects are designed to serve all citizens and businesses. We strive to offer a consistent level of service to all, to distribute public investment throughout the community and to respond to gaps in services identified in various City plans. We recognize the need to maintain affordability and predictability for utility customers and we are committed to delivering work that is</li> </ul>	

both financially and environmentally responsible. This project is specifically designed to assist low-income residents get caught up on their City utility bills.

- How will data be collected, analyzed, and reported concerning the effect of the program/policy by racial, ethnic, gender identity, national origin, income level, disability, sexual orientation, or other existing disparities?

N/A

- How will data be collected regarding the effectiveness of this program, policy, or product to ensure it is the right solution?

Public Works follows the City's established procurement and public works bidding regulations and policies to bring items forward, and then uses contract management best practices to ensure desired outcomes and regulatory compliance.

- Describe how this proposal aligns with current City Policies, including the Comprehensive Plan, Sustainability Action Plan, Capital Improvement Program, Neighborhood Master Plans, Council Resolutions, and others?

This work is consistent with annual budget strategies to limit costs and approved projects in the 6-year CIP.

### **Council Subcommittee Review**

- Please provide a summary of council subcommittee review. If not reviewed by a council subcommittee, please explain why not.



**City of Spokane**  
**CONTRACT RENEWAL**  
**Title: PAVING SERVICES - ON-CALL**  
**PUBLIC WORKS MAINTENANCE**

This Contract Renewal is made and entered into by and between the **CITY OF SPOKANE** a (“City”), Washington municipal corporation and **SHAMROCK PAVING, INC.**, whose address is P.O. Box 19263, Spokane, Washington 99219 as (“Contractor”), individually hereafter referenced as a “party”, and together as the “parties”.

*WHEREAS, the parties entered into an agreement wherein Contractor agreed to provide Paving Services - On-Call Public Works Maintenance for the City of Spokane; and*

*WHEREAS, the initial contract provided for one (1) additional one-year renewal.*

*NOW, THEREFORE, in consideration of these terms, the parties mutually agree as follows:*

**1. CONTRACT DOCUMENTS.**

The original Contract dated July 14, 2021, any previous amendments, renewals and/or extensions thereto, are incorporated by reference into this document as though written in full and shall remain in full force and effect except as provided herein.

**2. EFFECTIVE DATES.**

This Contract Renewal shall become effective July 1, 2024 and end June 30, 2025.

**3. COMPENSATION.**

The City shall pay a maximum amount not to exceed **TWO HUNDRED FIFTY THOUSAND AND 00/100 DOLLARS (\$250,000.00)**, excluding taxes, for everything furnished and done under this Contract Renewal. This is the maximum amount to be paid under this Renewal, and shall not be exceeded without the prior written authorization of the City, memorialized with the same formality as the original Contract and this Renewal document.

**4. DEBARMENT AND SUSPENSION.**

The Contractor has provided its certification that it is in compliance with and shall not contract with individuals or organizations which are debarred, suspended, or otherwise excluded from or ineligible from participation in Federal Assistance Programs under Executive Order 12549 and “Debarment and Suspension”, codified at 29 CFR part 98.



IN WITNESS WHEREOF, in consideration of the terms, conditions and covenants contained, or attached and incorporated and made a part, the parties have executed this Contract Renewal by having legally-binding representatives affix their signatures below.

**SHAMROCK PAVING, INC.**

**CITY OF SPOKANE**

By \_\_\_\_\_  
Signature                      Date

By \_\_\_\_\_  
Signature                      Date

\_\_\_\_\_  
Type or Print Name

\_\_\_\_\_  
Type or Print Name

\_\_\_\_\_  
Title

\_\_\_\_\_  
Title

Attest:

Approved as to form:

\_\_\_\_\_  
City Clerk

\_\_\_\_\_  
Assistant City Attorney

**Attachments that are part of this Agreement:**

Certificate of Debarment  
2024 Rate Sheet

24-081

**CERTIFICATION REGARDING DEBARMENT, SUSPENSION,  
INELIGIBILITY AND VOLUNTARY EXCLUSION**

1. The undersigned (i.e., signatory for the Subrecipient / Contractor / Consultant) certifies, to the best of its knowledge and belief, that it and its principals:
  - a. Are not presently debarred, suspended, proposed for debarment, declared ineligible, or voluntarily excluded from covered transactions by any federal department or agency;
  - b. Have not within a three-year period preceding this contract been convicted or had a civil judgment rendered against them for commission of fraud or a criminal offense in connection with obtaining, attempting to obtain, or performing a public (federal, state, or local) transaction or contract under a public transaction; violation of federal or state antitrust statutes or commission of embezzlement, theft, forgery, bribery, falsification or destruction of records, making false statements, tax evasion, receiving stolen property, making false claims, or obstruction of justice;
  - c. Are not presently indicted or otherwise criminally or civilly charged by a government entity (federal, state, or local) with commission of any of the offenses enumerated in paragraph (1)(b) of this certification; and,
  - d. Have not within a three-year period preceding this contract had one or more public transactions (federal, state, or local) terminated for cause or default.
  
2. The undersigned agrees by signing this contract that it shall not knowingly enter into any lower tier covered transaction with a person who is debarred, suspended, declared ineligible, or voluntarily excluded from participation in this covered transaction.
  
3. The undersigned further agrees by signing this contract that it will include the following clause, without modification, in all lower tier covered transactions and in all solicitations for lower tier covered transactions:

Certification Regarding Debarment, Suspension, Ineligibility and Voluntary Exclusion – Lower Tier Covered Transactions

1. The lower tier contractor certified, by signing this contract that neither it nor its principals is presently debarred, suspended, proposed for debarment, declared ineligible, or voluntarily excluded from participation in this transaction by any federal department or agency.
  
2. Where the lower tier contractor is unable to certify to any of the statements in this contract, such contractor shall attach an explanation to this contract.
  
4. I understand that a false statement of this certification may be grounds for termination of the contract.

<hr/> Name of Subrecipient / Contractor / Consultant (Type or Print)	<hr/> Program Title (Type or Print)
<hr/> Name of Certifying Official (Type or Print)	<hr/> Signature
<hr/> Title of Certifying Official (Type or Print)	<hr/> Date (Type or Print)



# CERTIFICATE OF LIABILITY INSURANCE

DATE (MM/DD/YYYY)

4/30/2024

THIS CERTIFICATE IS ISSUED AS A MATTER OF INFORMATION ONLY AND CONFERS NO RIGHTS UPON THE CERTIFICATE HOLDER. THIS CERTIFICATE DOES NOT AFFIRMATIVELY OR NEGATIVELY AMEND, EXTEND OR ALTER THE COVERAGE AFFORDED BY THE POLICIES BELOW. THIS CERTIFICATE OF INSURANCE DOES NOT CONSTITUTE A CONTRACT BETWEEN THE ISSUING INSURER(S), AUTHORIZED REPRESENTATIVE OR PRODUCER, AND THE CERTIFICATE HOLDER.

**IMPORTANT:** If the certificate holder is an ADDITIONAL INSURED, the policy(ies) must have ADDITIONAL INSURED provisions or be endorsed. If SUBROGATION IS WAIVED, subject to the terms and conditions of the policy, certain policies may require an endorsement. A statement on this certificate does not confer any rights to the certificate holder in lieu of such endorsement(s).

<b>PRODUCER</b> Propel Insurance 601 Union Street; Suite 3400 COM Construction Seattle, WA 98101-1371	CONTACT NAME: <b>Michael Mueller</b>
	PHONE (A/C, No, Ext): <b>800 499-0933</b> FAX (A/C, No): <b>866 577-1326</b> E-MAIL ADDRESS: <b>michael.mueller@propelinsurance.com</b>
<b>INSURED</b> Shamrock Paving Inc. P.O. Box 19263 Spokane, WA 99219	INSURER(S) AFFORDING COVERAGE      NAIC #
	INSURER A : Zurich American Insurance Company <b>16535</b>
	INSURER B : American Guarantee and Liability Ins.Co <b>26247</b>
	INSURER C :
	INSURER D :
	INSURER E :

**COVERAGES      CERTIFICATE NUMBER:      REVISION NUMBER:**

THIS IS TO CERTIFY THAT THE POLICIES OF INSURANCE LISTED BELOW HAVE BEEN ISSUED TO THE INSURED NAMED ABOVE FOR THE POLICY PERIOD INDICATED. NOTWITHSTANDING ANY REQUIREMENT, TERM OR CONDITION OF ANY CONTRACT OR OTHER DOCUMENT WITH RESPECT TO WHICH THIS CERTIFICATE MAY BE ISSUED OR MAY PERTAIN, THE INSURANCE AFFORDED BY THE POLICIES DESCRIBED HEREIN IS SUBJECT TO ALL THE TERMS, EXCLUSIONS AND CONDITIONS OF SUCH POLICIES. LIMITS SHOWN MAY HAVE BEEN REDUCED BY PAID CLAIMS.

INSR LTR	TYPE OF INSURANCE	ADDL INSR	SUBR WVD	POLICY NUMBER	POLICY EFF (MM/DD/YYYY)	POLICY EXP (MM/DD/YYYY)	LIMITS
A	<input checked="" type="checkbox"/> COMMERCIAL GENERAL LIABILITY <input type="checkbox"/> CLAIMS-MADE <input checked="" type="checkbox"/> OCCUR <input checked="" type="checkbox"/> BI/PD Ded: \$25,000 GEN'L AGGREGATE LIMIT APPLIES PER: <input type="checkbox"/> POLICY <input checked="" type="checkbox"/> PRO-JECT <input type="checkbox"/> LOC OTHER:			GLA039838107	03/31/2024	03/31/2025	EACH OCCURRENCE      \$2,000,000 DAMAGE TO RENTED PREMISES (Ea occurrence)      \$1,000,000 MED EXP (Any one person)      \$10,000 PERSONAL & ADV INJURY      \$2,000,000 GENERAL AGGREGATE      \$4,000,000 PRODUCTS - COMP/OP AGG      \$4,000,000 \$
A	AUTOMOBILE LIABILITY <input checked="" type="checkbox"/> ANY AUTO OWNED AUTOS ONLY <input type="checkbox"/> SCHEDULED AUTOS <input checked="" type="checkbox"/> HIRED AUTOS ONLY <input checked="" type="checkbox"/> NON-OWNED AUTOS ONLY			GLA039838107	03/31/2024	03/31/2025	COMBINED SINGLE LIMIT (Ea accident)      \$2,000,000 BODILY INJURY (Per person)      \$ BODILY INJURY (Per accident)      \$ PROPERTY DAMAGE (Per accident)      \$ PD DED      \$25,000
B	<input checked="" type="checkbox"/> UMBRELLA LIAB <input checked="" type="checkbox"/> OCCUR <input type="checkbox"/> EXCESS LIAB <input type="checkbox"/> CLAIMS-MADE DED      RETENTION \$			AUC039848407	03/31/2024	03/31/2025	EACH OCCURRENCE      \$1,000,000 AGGREGATE      \$1,000,000 \$
A	WORKERS COMPENSATION AND EMPLOYERS' LIABILITY ANY PROPRIETOR/PARTNER/EXECUTIVE OFFICER/MEMBER EXCLUDED?    Y/N (Mandatory in NH) <input checked="" type="checkbox"/> N If yes, describe under DESCRIPTION OF OPERATIONS below		N/A	GLA039838107 WA STOP GAP	03/31/2024	03/31/2025	<input type="checkbox"/> PER STATUTE <input checked="" type="checkbox"/> OTH-ER E.L. EACH ACCIDENT      \$1,000,000 E.L. DISEASE - EA EMPLOYEE      \$1,000,000 E.L. DISEASE - POLICY LIMIT      \$1,000,000

DESCRIPTION OF OPERATIONS / LOCATIONS / VEHICLES (ACORD 101, Additional Remarks Schedule, may be attached if more space is required)  
**RE: On Call Paving Contract Renewal**  
**City of Spokane is included as additional insured**

<b>CERTIFICATE HOLDER</b> City of Spokane 808 W. Spokane Falls Blvd. Spokane, WA 99201-0000	<b>CANCELLATION</b> SHOULD ANY OF THE ABOVE DESCRIBED POLICIES BE CANCELLED BEFORE THE EXPIRATION DATE THEREOF, NOTICE WILL BE DELIVERED IN ACCORDANCE WITH THE POLICY PROVISIONS. AUTHORIZED REPRESENTATIVE 
--	--



# Coverage Extension Endorsement

**THIS ENDORSEMENT CHANGES THE POLICY. PLEASE READ IT CAREFULLY.**

Policy No. GLA0398381-07

Effective Date: 03/31/2024

This endorsement modifies insurance provided under the:

**Business Auto Coverage Form**  
**Motor Carrier Coverage Form**

## A. Amended Who Is An Insured

1. The following is added to the **Who Is An Insured** Provision in **Section II – Covered Autos Liability Coverage**:

The following are also "insureds":

- a. Any "employee" of yours is an "insured" while using a covered "auto" you don't own, hire or borrow for acts performed within the scope of employment by you. Any "employee" of yours is also an "insured" while operating an "auto" hired or rented under a contract or agreement in an "employee's" name, with your permission, while performing duties related to the conduct of your business.
- b. Anyone volunteering services to you is an "insured" while using a covered "auto" you don't own, hire or borrow to transport your clients or other persons in activities necessary to your business.
- c. Anyone else who furnishes an "auto" referenced in Paragraphs **A.1.a.** and **A.1.b.** in this endorsement.
- d. Where and to the extent permitted by law, any person(s) or organization(s) where required by written contract or written agreement with you executed prior to any "accident", including those person(s) or organization(s) directing your work pursuant to such written contract or written agreement with you, provided the "accident" arises out of operations governed by such contract or agreement and only up to the limits required in the written contract or written agreement, or the Limits of Insurance shown in the Declarations, whichever is less.

2. The following is added to the **Other Insurance** Condition in the Business Auto Coverage Form and the **Other Insurance – Primary and Excess Insurance Provisions Condition** in the Motor Carrier Coverage Form:

Coverage for any person(s) or organization(s), where required by written contract or written agreement with you executed prior to any "accident", will apply on a primary and non-contributory basis and any insurance maintained by the additional "insured" will apply on an excess basis. However, in no event will this coverage extend beyond the terms and conditions of the Coverage Form.

## B. Amendment – Supplementary Payments

Paragraphs **a.(2)** and **a.(4)** of the **Coverage Extensions** Provision in **Section II – Covered Autos Liability Coverage** are replaced by the following:

- (2) Up to \$5,000 for the cost of bail bonds (including bonds for related traffic law violations) required because of an "accident" we cover. We do not have to furnish these bonds.
- (4) All reasonable expenses incurred by the "insured" at our request, including actual loss of earnings up to \$500 a day because of time off from work.

## C. Fellow Employee Coverage

The **Fellow Employee** Exclusion contained in **Section II – Covered Autos Liability Coverage** does not apply.

#### **D. Driver Safety Program Liability and Physical Damage Coverage**

1. The following is added to the **Racing** Exclusion in **Section II – Covered Autos Liability Coverage**:

This exclusion does not apply to covered "autos" participating in a driver safety program event, such as, but not limited to, auto or truck rodeos and other auto or truck agility demonstrations.

2. The following is added to Paragraph **2.** in **B. Exclusions** of **Section III – Physical Damage Coverage** of the Business Auto Coverage Form and Paragraph **2.b.** in **B. Exclusions** of **Section IV – Physical Damage Coverage** of the Motor Carrier Coverage Form:

This exclusion does not apply to covered "autos" participating in a driver safety program event, such as, but not limited to, auto or truck rodeos and other auto or truck agility demonstrations.

#### **E. Lease or Loan Gap Coverage**

The following is added to the **Coverage** Provision of the **Physical Damage Coverage** Section:

##### **Lease Or Loan Gap Coverage**

In the event of a total "loss" to a covered "auto", we will pay any unpaid amount due on the lease or loan for a covered "auto", less:

- a. Any amount paid under the **Physical Damage Coverage** Section of the Coverage Form; and
- b. Any:
  - (1) Overdue lease or loan payments at the time of the "loss";
  - (2) Financial penalties imposed under a lease for excessive use, abnormal wear and tear or high mileage;
  - (3) Security deposits not returned by the lessor;
  - (4) Costs for extended warranties, credit life insurance, health, accident or disability insurance purchased with the loan or lease; and
  - (5) Carry-over balances from previous leases or loans.

#### **F. Towing and Labor**

Paragraph **A.2.** of the **Physical Damage Coverage** Section is replaced by the following:

We will pay up to \$75 for towing and labor costs incurred each time a covered "auto" that is a "private passenger type", light truck or medium truck is disabled. However, the labor must be performed at the place of disablement.

As used in this provision, "private passenger type" means a private passenger or station wagon type "auto" and includes an "auto" of the pickup or van type if not used for business purposes.

#### **G. Extended Glass Coverage**

The following is added to Paragraph **A.3.a.** of the **Physical Damage Coverage** Section:

If glass must be replaced, the deductible shown in the Declarations will apply. However, if glass can be repaired and is actually repaired rather than replaced, the deductible will be waived. You have the option of having the glass repaired rather than replaced.

#### **H. Hired Auto Physical Damage – Increased Loss of Use Expenses**

The **Coverage Extension** for **Loss Of Use Expenses** in the **Physical Damage Coverage** Section is replaced by the following:

##### **Loss Of Use Expenses**

For Hired Auto Physical Damage, we will pay expenses for which an "insured" becomes legally responsible to pay for loss of use of a vehicle rented or hired without a driver under a written rental contract or written rental agreement. We will pay for loss of use expenses if caused by:

- (1) Other than collision only if the Declarations indicate that Comprehensive Coverage is provided for any covered "auto";

- (2) Specified Causes Of Loss only if the Declarations indicate that Specified Causes Of Loss Coverage is provided for any covered "auto"; or
  - (3) Collision only if the Declarations indicate that Collision Coverage is provided for any covered "auto".
- However, the most we will pay for any expenses for loss of use is \$100 per day, to a maximum of \$3000.

#### I. Personal Effects Coverage

The following is added to the **Coverage** Provision of the **Physical Damage Coverage** Section:

##### Personal Effects Coverage

- a. We will pay up to \$750 for "loss" to personal effects which are:
  - (1) Personal property owned by an "insured"; and
  - (2) In or on a covered "auto".
- b. Subject to Paragraph a. above, the amount to be paid for "loss" to personal effects will be based on the lesser of:
  - (1) The reasonable cost to replace; or
  - (2) The actual cash value.
- c. The coverage provided in Paragraphs a. and b. above, only applies in the event of a total theft of a covered "auto". No deductible applies to this coverage. However, we will not pay for "loss" to personal effects of any of the following:
  - (1) Accounts, bills, currency, deeds, evidence of debt, money, notes, securities, or commercial paper or other documents of value.
  - (2) Bullion, gold, silver, platinum, or other precious alloys or metals; furs or fur garments; jewelry, watches, precious or semi-precious stones.
  - (3) Paintings, statuary and other works of art.
  - (4) Contraband or property in the course of illegal transportation or trade.
  - (5) Tapes, records, discs or other similar devices used with audio, visual or data electronic equipment.

Any coverage provided by this Provision is excess over any other insurance coverage available for the same "loss".

#### J. Tapes, Records and Discs Coverage

- 1. The Exclusion in Paragraph B.4.a. of **Section III – Physical Damage Coverage** in the Business Auto Coverage Form and the Exclusion in Paragraph B.2.c. of **Section IV – Physical Damage Coverage** in the Motor Carrier Coverage Form does not apply.
- 2. The following is added to Paragraph 1.a. **Comprehensive Coverage** under the **Coverage** Provision of the **Physical Damage Coverage** Section:

We will pay for "loss" to tapes, records, discs or other similar devices used with audio, visual or data electronic equipment. We will pay only if the tapes, records, discs or other similar audio, visual or data electronic devices:

- (a) Are the property of an "insured"; and
- (b) Are in a covered "auto" at the time of "loss".

The most we will pay for such "loss" to tapes, records, discs or other similar devices is \$500. The **Physical Damage Coverage Deductible** Provision does not apply to such "loss".

#### K. Airbag Coverage

The Exclusion in Paragraph B.3.a. of **Section III – Physical Damage Coverage** in the Business Auto Coverage Form and the Exclusion in Paragraph B.4.a. of **Section IV – Physical Damage Coverage** in the Motor Carrier Coverage Form does not apply to the accidental discharge of an airbag.

#### L. Two or More Deductibles

The following is added to the **Deductible** Provision of the **Physical Damage Coverage** Section:

If an accident is covered both by this policy or Coverage Form and by another policy or Coverage Form issued to you by us, the following applies for each covered "auto" on a per vehicle basis:

1. If the deductible on this policy or Coverage Form is the smaller (or smallest) deductible, it will be waived; or
2. If the deductible on this policy or Coverage Form is not the smaller (or smallest) deductible, it will be reduced by the amount of the smaller (or smallest) deductible.

#### **M. Temporary Substitute Autos – Physical Damage**

1. The following is added to **Section I – Covered Autos**:

##### **Temporary Substitute Autos – Physical Damage**

If Physical Damage Coverage is provided by this Coverage Form on your owned covered "autos", the following types of vehicles are also covered "autos" for Physical Damage Coverage:

Any "auto" you do not own when used with the permission of its owner as a temporary substitute for a covered "auto" you do own but is out of service because of its:

1. Breakdown;
  2. Repair;
  3. Servicing;
  4. "Loss"; or
  5. Destruction.
2. The following is added to the Paragraph **A. Coverage** Provision of the **Physical Damage Coverage** Section:

##### **Temporary Substitute Autos – Physical Damage**

We will pay the owner for "loss" to the temporary substitute "auto" unless the "loss" results from fraudulent acts or omissions on your part. If we make any payment to the owner, we will obtain the owner's rights against any other party.

The deductible for the temporary substitute "auto" will be the same as the deductible for the covered "auto" it replaces.

#### **N. Amended Duties In The Event Of Accident, Claim, Suit Or Loss**

Paragraph **a.** of the **Duties In The Event Of Accident, Claim, Suit Or Loss** Condition is replaced by the following:

- a.** In the event of "accident", claim, "suit" or "loss", you must give us or our authorized representative prompt notice of the "accident", claim, "suit" or "loss". However, these duties only apply when the "accident", claim, "suit" or "loss" is known to you (if you are an individual), a partner (if you are a partnership), a member (if you are a limited liability company) or an executive officer or insurance manager (if you are a corporation). The failure of any agent, servant or employee of the "insured" to notify us of any "accident", claim, "suit" or "loss" shall not invalidate the insurance afforded by this policy.

Include, as soon as practicable:

- (1) How, when and where the "accident" or "loss" occurred and if a claim is made or "suit" is brought, written notice of the claim or "suit" including, but not limited to, the date and details of such claim or "suit";
- (2) The "insured's" name and address; and
- (3) To the extent possible, the names and addresses of any injured persons and witnesses.

If you report an "accident", claim, "suit" or "loss" to another insurer when you should have reported to us, your failure to report to us will not be seen as a violation of these amended duties provided you give us notice as soon as practicable after the fact of the delay becomes known to you.

#### **O. Waiver of Transfer Of Rights Of Recovery Against Others To Us**

The following is added to the **Transfer Of Rights Of Recovery Against Others To Us** Condition:

This Condition does not apply to the extent required of you by a written contract, executed prior to any "accident" or "loss", provided that the "accident" or "loss" arises out of operations contemplated by such contract. This waiver only applies to the person or organization designated in the contract.

#### **P. Employee Hired Autos – Physical Damage**

Paragraph **b.** of the **Other Insurance** Condition in the Business Auto Coverage Form and Paragraph **f.** of the **Other Insurance – Primary and Excess Insurance Provisions** Condition in the Motor Carrier Coverage Form are replaced by the following:

For Hired Auto Physical Damage Coverage, the following are deemed to be covered "autos" you own:

- (1) Any covered "auto" you lease, hire, rent or borrow; and
- (2) Any covered "auto" hired or rented under a written contract or written agreement entered into by an "employee" or elected or appointed official with your permission while being operated within the course and scope of that "employee's" employment by you or that elected or appointed official's duties as respect their obligations to you.

However, any "auto" that is leased, hired, rented or borrowed with a driver is not a covered "auto".

#### **Q. Unintentional Failure to Disclose Hazards**

The following is added to the **Concealment, Misrepresentation Or Fraud** Condition:

However, we will not deny coverage under this Coverage Form if you unintentionally:

- (1) Fail to disclose any hazards existing at the inception date of this Coverage Form; or
- (2) Make an error, omission, improper description of "autos" or other misstatement of information.

You must notify us as soon as possible after the discovery of any hazards or any other information that was not provided to us prior to the acceptance of this policy.

#### **R. Hired Auto – World Wide Coverage**

Paragraph **7.b.(5)** of the **Policy Period, Coverage Territory** Condition is replaced by the following:

- (5) Anywhere else in the world if a covered "auto" is leased, hired, rented or borrowed for a period of 60 days or less,

#### **S. Bodily Injury Redefined**

The definition of "bodily injury" in the **Definitions** Section is replaced by the following:

"Bodily injury" means bodily injury, sickness or disease, sustained by a person including death or mental anguish, resulting from any of these at any time. Mental anguish means any type of mental or emotional illness or disease.

#### **T. Expected Or Intended Injury**

The **Expected Or Intended Injury** Exclusion in Paragraph **B. Exclusions** under **Section II – Covered Auto Liability Coverage** is replaced by the following:

##### **Expected Or Intended Injury**

"Bodily injury" or "property damage" expected or intended from the standpoint of the "insured". This exclusion does not apply to "bodily injury" or "property damage" resulting from the use of reasonable force to protect persons or property.

#### **U. Physical Damage – Additional Temporary Transportation Expense Coverage**

Paragraph **A.4.a.** of **Section III – Physical Damage Coverage** is replaced by the following:

##### **4. Coverage Extensions**

###### **a. Transportation Expenses**

We will pay up to \$50 per day to a maximum of \$1,000 for temporary transportation expense incurred by you because of the total theft of a covered "auto" of the private passenger type. We will pay only for those covered "autos" for which you carry either Comprehensive or Specified Causes of Loss Coverage. We will pay for temporary transportation expenses incurred during the period beginning 48 hours after the theft and ending, regardless of the policy's expiration, when the covered "auto" is returned to use or we pay for its "loss".



#### **V. Replacement of a Private Passenger Auto with a Hybrid or Alternative Fuel Source Auto**

The following is added to Paragraph **A. Coverage** of the **Physical Damage Coverage** Section:

In the event of a total "loss" to a covered "auto" of the private passenger type that is replaced with a hybrid "auto" or "auto" powered by an alternative fuel source of the private passenger type, we will pay an additional 10% of the cost of the replacement "auto", excluding tax, title, license, other fees and any aftermarket vehicle upgrades, up to a maximum of \$2500. The covered "auto" must be replaced by a hybrid "auto" or an "auto" powered by an alternative fuel source within 60 calendar days of the payment of the "loss" and evidenced by a bill of sale or new vehicle lease agreement.

To qualify as a hybrid "auto", the "auto" must be powered by a conventional gasoline engine and another source of propulsion power. The other source of propulsion power must be electric, hydrogen, propane, solar or natural gas, either compressed or liquefied. To qualify as an "auto" powered by an alternative fuel source, the "auto" must be powered by a source of propulsion power other than a conventional gasoline engine. An "auto" solely propelled by biofuel, gasoline or diesel fuel or any blend thereof is not an "auto" powered by an alternative fuel source.

#### **W. Return of Stolen Automobile**

The following is added to the **Coverage Extension** Provision of the **Physical Damage Coverage** Section:

If a covered "auto" is stolen and recovered, we will pay the cost of transport to return the "auto" to you. We will pay only for those covered "autos" for which you carry either Comprehensive or Specified Causes of Loss Coverage.

All other terms, conditions, provisions and exclusions of this policy remain the same.



# Additional Insured – Automatic – Owners, Lessees Or Contractors

**THIS ENDORSEMENT CHANGES THE POLICY. PLEASE READ IT CAREFULLY.**

Policy No. GLA 0398381-07

Effective Date: 03/31/2024

This endorsement modifies insurance provided under the:

## **Commercial General Liability Coverage Part**

**A. Section II – Who Is An Insured** is amended to include as an additional insured any person or organization whom you are required to add as an additional insured under a written contract or written agreement executed by you, but only with respect to liability for "bodily injury", "property damage" or "personal and advertising injury" and subject to the following:

1. If such written contract or written agreement specifically requires that you provide that the person or organization be named as an additional insured under one or both of the following endorsements:

- a. The Insurance Services Office (ISO) ISO CG 20 10 (10/01 edition); or
- b. The ISO CG 20 37 (10/01 edition),

such person or organization is then an additional insured with respect to such endorsement(s), but only to the extent that "bodily injury", "property damage" or "personal and advertising injury" arises out of:

- (1) Your ongoing operations, with respect to Paragraph 1.a. above; or
- (2) "Your work", with respect to Paragraph 1.b. above,  
which is the subject of the written contract or written agreement.

However, solely with respect to this Paragraph 1., insurance afforded to such additional insured:

- (a) Only applies if the "bodily injury", "property damage" or "personal and advertising injury" offense occurs during the policy period and subsequent to your execution of the written contract or written agreement; and
- (b) Does not apply to "bodily injury" or "property damage" caused by "your work" and included within the "products-completed operations hazard" unless the written contract or written agreement specifically requires that you provide such coverage to such additional insured.

2. If such written contract or written agreement specifically requires that you provide that the person or organization be named as an additional insured under one or both of the following endorsements:

- a. The Insurance Services Office (ISO) ISO CG 20 10 (07/04 edition); or
- b. The ISO CG 20 37 (07/04 edition),

such person or organization is then an additional insured with respect to such endorsement(s), but only to the extent that "bodily injury", "property damage" or "personal and advertising injury" is caused, in whole or in part, by:

- (1) Your acts or omissions; or
- (2) The acts or omissions of those acting on your behalf,

in the performance of:

- (a) Your ongoing operations, with respect to Paragraph 2.a. above; or
- (b) "Your work" and included in the "products-completed operations hazard", with respect to Paragraph 2.b. above,

which is the subject of the written contract or written agreement.

However, solely with respect to this Paragraph 2., insurance afforded to such additional insured:

- (i) Only applies if the "bodily injury", "property damage" or "personal and advertising injury" offense occurs during the policy period and subsequent to your execution of the written contract or written agreement; and
  - (ii) Does not apply to "bodily injury" or "property damage" caused by "your work" and included within the "products-completed operations hazard" unless the written contract or written agreement specifically requires that you provide such coverage to such additional insured.
3. If neither Paragraph 1. nor Paragraph 2. above apply and such written contract or written agreement requires that you provide that the person or organization be named as an additional insured:

- a. Under the ISO CG 20 10 (04/13 edition, any subsequent edition or if no edition date is specified); or
- b. With respect to ongoing operations (if no form is specified),

such person or organization is then an additional insured only to the extent that "bodily injury", "property damage" or "personal and advertising injury" is caused, in whole or in part by:

- (1) Your acts or omissions; or
- (2) The acts or omissions of those acting on your behalf,

in the performance of your ongoing operations, which is the subject of the written contract or written agreement.

However, solely with respect to this Paragraph 3., insurance afforded to such additional insured:

- (a) Only applies to the extent permitted by law;
  - (b) Will not be broader than that which you are required by the written contract or written agreement to provide for such additional insured; and
  - (c) Only applies if the "bodily injury", "property damage" or "personal and advertising injury" offense occurs during the policy period and subsequent to your execution of the written contract or written agreement.
4. If neither Paragraph 1. nor Paragraph 2. above apply and such written contract or written agreement requires that you provide that the person or organization be named as an additional insured:

- a. Under the ISO CG 20 37 (04/13 edition, any subsequent edition or if no edition date is specified); or
- b. With respect to the "products-completed operations hazard" (if no form is specified),

such person or organization is then an additional insured only to the extent that "bodily injury" or "property damage" is caused, in whole or in part by "your work" and included in the "products-completed operations hazard", which is the subject of the written contract or written agreement.

However, solely with respect to this Paragraph 4., insurance afforded to such additional insured:

- (1) Only applies to the extent permitted by law;
- (2) Will not be broader than that which you are required by the written contract or written agreement to provide for such additional insured;
- (3) Only applies if the "bodily injury" or "property damage" occurs during the policy period and subsequent to your execution of the written contract or written agreement; and
- (4) Does not apply to "bodily injury" or "property damage" caused by "your work" and included within the "products-completed operations hazard" unless the written contract or written agreement specifically requires that you provide such coverage to such additional insured.

- B.** Solely with respect to the insurance afforded to any additional insured referenced in Section **A.** of this endorsement, the following additional exclusion applies:

This insurance does not apply to "bodily injury", "property damage" or "personal and advertising injury" arising out of the rendering of, or failure to render, any professional architectural, engineering or surveying services including:

1. The preparing, approving or failing to prepare or approve maps, shop drawings, opinions, reports, surveys, field orders, change orders or drawings and specifications; or
2. Supervisory, inspection, architectural or engineering activities.

This exclusion applies even if the claims against any insured allege negligence or other wrongdoing in the supervision, hiring, employment, training or monitoring of others by that insured, if the "occurrence" which caused the "bodily injury" or "property damage", or the offense which caused the "personal and advertising injury", involved the rendering of or the failure to render any professional architectural, engineering or surveying services.

- C.** Solely with respect to the coverage provided by this endorsement, the following is added to Paragraph **2. Duties In The Event Of Occurrence, Offense, Claim Or Suit** of Section **IV – Commercial General Liability Conditions**:

The additional insured must see to it that:

- (1) We are notified as soon as practicable of an "occurrence" or offense that may result in a claim;
- (2) We receive written notice of a claim or "suit" as soon as practicable; and
- (3) A request for defense and indemnity of the claim or "suit" will promptly be brought against any policy issued by another insurer under which the additional insured may be an insured in any capacity. This provision does not apply to insurance on which the additional insured is a Named Insured if the written contract or written agreement requires that this coverage be primary and non-contributory.

- D.** Solely with respect to the coverage provided by this endorsement:

1. The following is added to the **Other Insurance** Condition of Section **IV – Commercial General Liability Conditions**:

**Primary and Noncontributory insurance**

This insurance is primary to and will not seek contribution from any other insurance available to an additional insured provided that:

- a. The additional insured is a Named Insured under such other insurance; and
- b. You are required by written contract or written agreement that this insurance be primary and not seek contribution from any other insurance available to the additional insured.

2. The following paragraph is added to Paragraph **4.b.** of the **Other Insurance** Condition under Section **IV – Commercial General Liability Conditions**:

This insurance is excess over:

Any of the other insurance, whether primary, excess, contingent or on any other basis, available to an additional insured, in which the additional insured on our policy is also covered as an additional insured on another policy providing coverage for the same "occurrence", offense, claim or "suit". This provision does not apply to any policy in which the additional insured is a Named Insured on such other policy and where our policy is required by a written contract or written agreement to provide coverage to the additional insured on a primary and non-contributory basis.

- E.** This endorsement does not apply to an additional insured which has been added to this Coverage Part by an endorsement showing the additional insured in a Schedule of additional insureds, and which endorsement applies specifically to that identified additional insured.

- F.** Solely with respect to the insurance afforded to an additional insured under Paragraph **A.3.** or Paragraph **A.4.** of this endorsement, the following is added to Section **III – Limits Of Insurance**:

**Additional Insured – Automatic – Owners, Lessees Or Contractors Limit**

The most we will pay on behalf of the additional insured is the amount of insurance:

1. Required by the written contract or written agreement referenced in Section **A.** of this endorsement; or
2. Available under the applicable Limits of Insurance shown in the Declarations,  
whichever is less.

This endorsement shall not increase the applicable Limits of Insurance shown in the Declarations.

All other terms, conditions, provisions and exclusions of this policy remain the same.

# Waiver Of Subrogation (Blanket) Endorsement

Policy No.	Eff. Date of Pol.	Exp. Date of Pol.	Eff. Date of End.	Producer	Add'l Prem.	Return Prem.
GLA 0398381-07	03/31/2024	03/31/2025		06191000	\$ <b>INCL</b>	\$

**THIS ENDORSEMENT CHANGES THE POLICY. PLEASE READ IT CAREFULLY.**

This endorsement modifies insurance provided under the:

## **Commercial General Liability Coverage Part**

The following is added to the **Transfer Of Rights Of Recovery Against Others To Us Condition:**

If you are required by a written contract or agreement, which is executed before a loss, to waive your rights of recovery from others, we agree to waive our rights of recovery. This waiver of rights shall not be construed to be a waiver with respect to any other operations in which the insured has no contractual interest.

**THIS ENDORSEMENT CHANGES THE POLICY. PLEASE READ IT CAREFULLY.**

## **DESIGNATED CONSTRUCTION PROJECT(S) GENERAL AGGREGATE LIMIT**

This endorsement modifies insurance provided under the following:

COMMERCIAL GENERAL LIABILITY COVERAGE PART

### **SCHEDULE**

**Designated Construction Project(s):**

ANY CONSTRUCTION PROJECT EXCEPT A CONSTRUCTION PROJECT FOR WHICH A CONSOLIDATED (WRAP-UP) OR SIMILAR INSURANCE PROGRAM HAS BEEN PROVIDED.

Information required to complete this Schedule, if not shown above, will be shown in the Declarations.

- A.** For all sums which the insured becomes legally obligated to pay as damages caused by "occurrences" under Section I – Coverage **A**, and for all medical expenses caused by accidents under Section I – Coverage **C**, which can be attributed only to ongoing operations at a single designated construction project shown in the Schedule above:
  - 1.** A separate Designated Construction Project General Aggregate Limit applies to each designated construction project, and that limit is equal to the amount of the General Aggregate Limit shown in the Declarations.
  - 2.** The Designated Construction Project General Aggregate Limit is the most we will pay for the sum of all damages under Coverage **A**, except damages because of "bodily injury" or "property damage" included in the "products-completed operations hazard", and for medical expenses under Coverage **C** regardless of the number of:
    - a.** Insureds;
    - b.** Claims made or "suits" brought; or
    - c.** Persons or organizations making claims or bringing "suits".
- 3.** Any payments made under Coverage **A** for damages or under Coverage **C** for medical expenses shall reduce the Designated Construction Project General Aggregate Limit for that designated construction project. Such payments shall not reduce the General Aggregate Limit shown in the Declarations nor shall they reduce any other Designated Construction Project General Aggregate Limit for any other designated construction project shown in the Schedule above.
- 4.** The limits shown in the Declarations for Each Occurrence, Damage To Premises Rented To You and Medical Expense continue to apply. However, instead of being subject to the General Aggregate Limit shown in the Declarations, such limits will be subject to the applicable Designated Construction Project General Aggregate Limit.

- B.** For all sums which the insured becomes legally obligated to pay as damages caused by "occurrences" under Section I – Coverage **A**, and for all medical expenses caused by accidents under Section I – Coverage **C**, which cannot be attributed only to ongoing operations at a single designated construction project shown in the Schedule above:
1. Any payments made under Coverage **A** for damages or under Coverage **C** for medical expenses shall reduce the amount available under the General Aggregate Limit or the Products-completed Operations Aggregate Limit, whichever is applicable; and
  2. Such payments shall not reduce any Designated Construction Project General Aggregate Limit.
- C.** When coverage for liability arising out of the "products-completed operations hazard" is provided, any payments for damages because of "bodily injury" or "property damage" included in the "products-completed operations hazard" will reduce the Products-completed Operations Aggregate Limit, and not reduce the General Aggregate Limit nor the Designated Construction Project General Aggregate Limit.
- D.** If the applicable designated construction project has been abandoned, delayed, or abandoned and then restarted, or if the authorized contracting parties deviate from plans, blueprints, designs, specifications or timetables, the project will still be deemed to be the same construction project.
- E.** The provisions of Section III – Limits Of Insurance not otherwise modified by this endorsement shall continue to apply as stipulated.





C. With respect to the insurance afforded to these additional insureds, the following is added to **Section III – Limits Of Insurance:**

The most we will pay on behalf of the additional insured is the amount of insurance:

1. Required by the contract or agreement; or

2. Available under the applicable limits of insurance;

whichever is less.

This endorsement shall not increase the applicable limits of insurance.

This page has been left blank intentionally.



# Washington - Blanket Notification To Others Of Cancellation

**THIS ENDORSEMENT CHANGES THE POLICY. PLEASE READ IT CAREFULLY.**

Policy No. GLA 0398381-07

Effective Date: 03/31/2024

This endorsement modifies insurance provided under the:

## **Commercial General Liability Coverage Part**

- A.** If we cancel this Coverage Part by written notice to the first Named Insured for any reason other than nonpayment of premium, we will deliver electronic notification that such Coverage Part has been cancelled to each person or organization issued a Certificate of Insurance shown in a Schedule provided to us by the First Named Insured. Such Schedule:
1. Must be initially provided to us within 15 days:
    - a. After the beginning of the policy period shown in the Declarations; or
    - b. After this endorsement has been added to policy;
  2. Must contain the names and e-mail addresses of only the persons or organizations requiring notification that such Coverage Part has been cancelled;
  3. Must be in an electronic format that is acceptable to us; and
  4. Must be accurate.
- Such Schedule may be updated and provided to us by the First Named Insured during the policy period. Such updated Schedule must comply with Paragraphs **2.**, **3.** and **4.** above.
- B.** Our delivery of the electronic notification as described in Paragraph **A.** of this endorsement will be based on the most recent Schedule in our records as of the date the notice of cancellation is mailed or delivered to the first Named Insured. Delivery of the notification as described in Paragraph **A.** of this endorsement will be completed as soon as practicable after the effective date of cancellation to the first Named Insured.
- C.** Proof of e-mailing the electronic notification will be sufficient proof that we have complied with Paragraphs **A.** and **B.** of this endorsement.
- D.** Our delivery of electronic notification described in Paragraphs **A.** and **B.** of this endorsement is intended as a courtesy only. Our failure to provide such delivery of electronic notification will not:
1. Extend the Coverage Part cancellation date;
  2. Negate the cancellation; or
  3. Provide any additional insurance that would not have been provided in the absence of this endorsement.
- E.** We are not responsible for the accuracy, integrity, timeliness and validity of information contained in the Schedule provided to us as described in Paragraphs **A.** and **B.** of this endorsement.

All other terms, conditions, provisions and exclusions of this policy remain the same.

# Washington Blanket Notification To Others Of Cancellation



**THIS ENDORSEMENT CHANGES THE POLICY. PLEASE READ IT CAREFULLY.**

Policy No. GLA 0398381-07

Effective Date: 03/31/2024

This endorsement modifies insurance provided under the:

**Auto Dealers Coverage Form**  
**Business Auto Coverage Form**  
**Motor Carrier Coverage Form**

- A.** If we cancel this Coverage Part by written notice to the first Named Insured for any reason other than nonpayment of premium, we will deliver electronic notification that such Coverage Part has been cancelled to each person or organization issued a Certificate of Insurance shown in a Schedule provided to us by the First Named Insured. Such Schedule:
1. Must be initially provided to us within 15 days:
    - a. After the beginning of the policy period shown in the Declarations; or
    - b. After this endorsement has been added to policy;
  2. Must contain the names and e-mail addresses of only the persons or organizations requiring notification that such Coverage Part has been cancelled;
  3. Must be in an electronic format that is acceptable to us; and
  4. Must be accurate.
- Such Schedule may be updated and provided to us by the First Named Insured during the policy period. Such updated Schedule must comply with Paragraphs **2.**, **3.** and **4.** above.
- B.** Our delivery of the electronic notification as described in Paragraph **A.** of this endorsement will be based on the most recent Schedule in our records as of the date the notice of cancellation is mailed or delivered to the first Named Insured. Delivery of the notification as described in Paragraph **A.** of this endorsement will be completed as soon as practicable after the effective date of cancellation to the first Named Insured.
- C.** Proof of e-mailing the electronic notification will be sufficient proof that we have complied with Paragraphs **A.** and **B.** of this endorsement.
- D.** Our delivery of electronic notification described in Paragraphs **A.** and **B.** of this endorsement is intended as a courtesy only. Our failure to provide such delivery of electronic notification will not:
1. Extend the Coverage Part cancellation date;
  2. Negate the cancellation; or
  3. Provide any additional insurance that would not have been provided in the absence of this endorsement.
- E.** We are not responsible for the accuracy, integrity, timeliness and validity of information contained in the Schedule provided to us as described in Paragraphs **A.** and **B.** of this endorsement.

All other terms, conditions, provisions and exclusions of this policy remain the same.



# Commercial Umbrella Liability Policy

There are provisions in this policy that restrict coverage. Read the entire policy carefully to determine your rights, duties and what is and is not covered.

Throughout this policy the words “you” and “your” refer to the **Named Insured** shown in the Declarations, and any other person or organization qualifying as a **named insured** under this policy. The words “we”, “us” and “our” refer to the company providing this insurance.

The word **insured** means any person or organization qualifying as such in **SECTION V. DEFINITIONS** of this policy.

Words and phrases that are printed in bold-face type are defined in this policy. These definitions are found in **SECTION V. DEFINITIONS** of this policy or in the specific policy provision where they appear.

In consideration of the payment of the premium and in reliance upon the statements in the Declarations and in accordance with the provisions of this policy we agree with you to provide coverage as follows:

## Insuring Agreements

### SECTION I. COVERAGE

#### A. Coverage A - Excess Follow Form Liability Insurance

Under **Coverage A**, we will pay on behalf of the **insured** those damages covered by this insurance in excess of the total applicable limits of **underlying insurance**. With respect to **Coverage A**, this policy includes:

1. The terms and conditions of **underlying insurance** to the extent such terms and conditions are not inconsistent or do not conflict with the terms and conditions referred to in Paragraph **2.** below; and
2. The terms and conditions that apply to **Coverage A** of this policy.

Notwithstanding anything to the contrary contained above, if **underlying insurance** does not apply to damages, for reasons other than exhaustion of applicable Limits of Insurance by payment of **loss**, then **Coverage A** does not apply to such damages. Also, **Coverage A** does not apply to any form of **casualty business crisis expense** insurance even if such insurance is afforded under **underlying insurance** or would have been afforded except for the exhaustion of the Limits of Insurance of **underlying insurance**.

#### B. Coverage B - Umbrella Liability Insurance

Under **Coverage B**, we will pay on behalf of the **insured** those damages the **insured** becomes legally obligated to pay by reason of liability:

1. Imposed by law because of **bodily injury, property damage, or personal and advertising injury**; or
2. Assumed under an **insured contract** because of **bodily injury or property damage**;

covered by this insurance but only if the injury, damage or offense arises out of your business, takes place during the policy period of this policy and is caused by an **occurrence** happening anywhere. We will pay such damages in excess of the **Retained Limit** specified in Item **5.** of the Declarations or the amount payable by **other insurance**, whichever is greater.

**Coverage B** does not apply to any **loss**, claim or **suit** for which insurance is afforded under **underlying insurance** or would have been afforded except for the exhaustion of the Limits of Insurance of **underlying insurance**.

The amount we will pay for **loss** under **Coverage A** or **Coverage B** is limited as described in **SECTION II. LIMITS OF INSURANCE**.

We have no obligation under **Coverage A** and/or **Coverage B** with respect to any settlement made without our consent.

The insurance afforded under **Coverage A** and **Coverage B** applies to **bodily injury or property damage** only if prior to the policy period, no **designated insured** knew that the **bodily injury or property damage** had occurred, in whole or in part. If such a **designated insured** knew, prior to the policy period, that the **bodily injury or property damage** occurred, then any continuation, change or resumption of such **bodily injury or property damage** during or after the policy period will be deemed to have been known prior to the policy period.

- c. The duties and requirements imposed upon any **insured** under this policy will not apply to any **non-admitted jurisdiction**. However, with respect to any claims made or **suits** brought in a **non-admitted jurisdiction**, it will be the duty of the first **Named Insured** to do or cause the applicable **qualified entity** to do such things as would be required of such **qualified entity** if **Coverage A** applied directly to such claim or **suit**, including:
  - (1) Make such investigation, defense or settlement as we deem reasonable;
  - (2) Obtain our approval for any payment; and
  - (3) Effect approved payments to others, in accordance with the terms and conditions of this insurance.
- d. Under **Coverage B**, this policy does not apply to any liability, damage, **loss**, cost or expense arising out of any operations or activities of a **qualified entity**.
- e. We will promptly pay the first **Named Insured** at the mailing address listed in Item **2**. of the Declarations the amount of damages covered under the terms of this policy. If the first **Named Insured** or any **qualified entity** recovers from any third party all or part of any amount that we have paid pursuant to this insurance, the first **Named Insured** will promptly reimburse the amount of any such recovery to us.

## 10. Legal Action Against Us

There will be no right of action against us under this insurance unless:

- a. You have complied with all the terms of this policy; and
- b. The amount you owe has been determined by settlement with our consent or by actual trial and final judgment.

This insurance does not give anyone the right to add us as a party in an action against you to determine your liability.

## 11. Maintenance of Underlying Insurance

During the period of this policy, you agree:

- a. To keep the policies listed in the Schedule of Underlying Insurance in full force and effect;
- b. That the Limits of Insurance of the policies listed in the Schedule of Underlying Insurance will be maintained except for any reduction or exhaustion of limits by payment of claims or **suits** for damages covered by **underlying insurance**;
- c. The policies listed in the Schedule of Underlying Insurance may not be canceled or not renewed by you without notifying us, and you agree to notify us in the event an insurance company cancels or declines to renew any policy listed in the Schedule of Underlying Insurance; and
- d. Renewals or replacements of the policies listed in the Schedule of Underlying Insurance will not be materially changed without our agreement.

If you fail to comply with these requirements, we will only be liable to the same extent that we would have been had you fully complied with these requirements.

## 12. Miscellaneous Unintentional Errors and Omissions

Any unintentional error or omission in the description of, or failure to describe completely, any premises or operations intended to be covered by this policy, shall not invalidate or affect the coverage for those operations or premises. However, the **insured** must report such error or omission to the company as soon as practicable after its discovery.

## 13. Other Insurance

If **other insurance** applies to damages that are also covered by this policy, this policy will apply excess of the **other insurance**. However, this provision will not apply:

- a. If the **other insurance** is written to be excess of this policy; or
- b. With respect to **Coverage A** only, if the **named insured** has agreed in a written contract to carry insurance to apply prior to and be non-contributory with that of another person or organization's insurance, but only as respects damages arising out of insured operations or work on behalf of the **named insured** performed under such written contract. The limits available to the other person or organization will be the lesser of the policy limits or the minimum limits required by such written contract. In that case, **other insurance** of that person or organization will apply as excess and not contribute prior to the insurance afforded by this policy.

Nothing herein will be construed to make this policy subject to the terms, conditions and limitations of such **other insurance**.

#### 14. Premium

The premium for this policy as stated in Item 6. of the Declarations is a flat premium. It is not subject to adjustment unless an endorsement is attached to this policy.

#### 15. Separation of Insureds

Except with respect to the Limits of Insurance, and any rights or duties specifically assigned to the first **Named Insured**, this insurance applies:

- a. As if each **named insured** were the only **named insured**; and
- b. Separately to each **insured** against whom claim is made or **suit** is brought.

#### 16. Terms Conformed to Statute

The terms of this policy which are in conflict with the statutes, laws, ordinances or regulations in any country, jurisdiction, state or province where this policy is issued are amended to conform to such statutes, laws, ordinances or regulations. If we are prevented by law or statute from paying on behalf of the **insured**, then we will, where permitted by law or statute, indemnify the **insured**.

#### 17. Transfer of Rights of Recovery Against Others to Us

- a. If the **insured** has rights to recover all or part of any payment we have made under this insurance, those rights are transferred to us. The **insured** must do nothing after the **loss** to impair them. At our request, the **insured** will bring **suit** or transfer those rights to us and help us enforce them.

However, if any **insured** is required by a written contract or agreement which is executed before a **loss** to waive their rights of recovery from others, we agree to waive our rights of recovery. This waiver of rights shall not be construed to be a waiver with respect to any other operations for which the **insured** has not waived their rights of recovery by contract.

- b. Any amount recovered will be apportioned in the inverse order of payment of **loss** to the extent of actual payment. The expenses of all such recovery proceedings will be apportioned in the ratio of respective recoveries.

#### 18. Transfer of Your Rights and Duties

Your rights and duties under this insurance may not be transferred without our written consent. If you die, then your rights and duties will be transferred to your legal representative, but only while acting within the scope of duties as your legal representative. Until your legal representative is appointed, anyone having temporary custody of your property will have your rights and duties but only with respect to that property.

#### 19. When Loss is Payable

Coverage under this policy will not apply until the **insured**, or the **insured's** underlying insurer has paid or is legally obligated to pay the full amount of the Underlying Limits of Insurance or **Retained Limit**.

When the amount of **loss** is determined by an agreed settlement or on a final judgment against an **insured** obtained after an actual trial, we will promptly pay on behalf of the **insured** the amount of **loss** covered under the terms of this policy. The first **Named Insured** will promptly reimburse us for any amount within the **Retained Limit** paid by us.

#### 20. Violation of Economic or Trade Sanctions

If coverage for a claim or **suit** under this policy is in violation of any economic or trade sanctions of the United States of America then coverage for that claim or **suit** will be null and void.

### B. The following Condition is applicable to **Coverage A** and **Coverage B**:

#### 1. Notice of Occurrence, Claim or Suit

- a. You must see to it that we are notified as soon as practicable of an **occurrence** which may result in damages covered by this policy.

To the extent possible, notice will include:

- (1) How, when and where the **occurrence** took place;





# Schedule of Underlying Insurance

Re: CENTRAL WASHINGTON ASPHALT, INC.

Coverage: Commercial Umbrella Liability Policy

Reference Number: 0398484-40

Our proposal is subject to the underlying limits of liability and coverages as stated below. All Underlying Insurance must be provided by a carrier with an A.M. Best rating of A-VII or better.

---

## Commercial General Liability

Carrier Group Name:	Zurich Insurance Group LTD		
Issuing Company:	Zurich American Insurance Company		
Policy Number:	GLA 0398381 07	Policy Period:	03/31/2024 to 03/31/2025
Coverages Included:	Premises and Products / Completed Ops		
Premises - Each Occurrence Limit:	\$2,000,000		
Retention Type:	Deductible	Retention ALAE:	In Addition to the Limit
Retention Amount:	\$25,000		
Products / Completed Ops - Each Occurrence	\$2,000,000		
Retention Type:	Deductible	Retention ALAE:	In Addition to the Limit
Retention Amount:	\$25,000		
General Aggregate:	\$4,000,000		
Products / Completed Operations Aggregate:	\$4,000,000		
Employee Benefits - Each Claim:	\$1,000,000		
Employee Benefits - General Aggregate:	\$2,000,000		
Retention Type:	Deductible	Retention ALAE:	In Addition to the Limit
Retention Amount:	\$1,000		
Terms and Conditions:			

---

## Auto Liability

Carrier Group Name:	Zurich Insurance Group LTD		
Issuing Company:	Zurich American Insurance Company		
Detailed Description of Policy:	TBD		
Policy Number:	GLA 0398381 07	Policy Period:	03/31/2024 to 03/31/2025
Combined Single Limit:	\$2,000,000		
Retention Type:	Deductible	Retention ALAE:	Erode the Limit
Retention Amount:	\$25,000		
Terms and Conditions:			



**ZURICH**<sup>®</sup>

## Schedule of Underlying Insurance

---

### Stop Gap

Carrier Group Name: Zurich Insurance Group LTD  
Issuing Company: Zurich American Insurance Company  
Detailed Description of Policy: TBD  
Policy Number: GLA 0398381 07      Policy Period: 03/31/2024 to 03/31/2025  
Bodily Injury By Accident - Each Accident: \$1,000,000  
Retention Type: None  
  
Bodily Injury By Disease - Each Employee: \$1,000,000  
Retention Type: None  
  
Bodily Injury By Disease - Policy Limit: \$1,000,000  
Terms and Conditions:

---

### Personal Umbrella Policy

Carrier Group Name: Other  
Issuing Company: Safeco Insurance Company of America  
Detailed Description of Policy: Pamp M. and Kimberly L. Maiers  
Policy Number: UH2015922      Policy Period: 06/16/2021 to 06/16/2022  
Each Occurrence Limit: \$5,000,000  
Retention Type: None  
  
Terms and Conditions:



# Schedule of Forms and Endorsements

Re: CENTRAL WASHINGTON ASPHALT, INC.

Coverage: Commercial Umbrella Liability Policy

Reference Number: 0398484-40

The following schedule contains a general description of the coverages provided. For a detailed description of the terms conditions, exclusions and limitations of this insurance you must refer to the applicable policy forms and endorsements identified.

	Title *	Form Number
Policy Form:	Commercial Umbrella Liability Policy	U-UMB-103-C CW (03/10)
Endorsement:	Important Notice - In Witness Clause	U-GU-319-F (01/09)
	Schedule Of Taxes, Surcharges Or Fees	U-GU-616-A CW (10/02)
	Disclosure of Important Information Relating to Terrorism Risk Insurance Act	U-GU-630-E CW (01/20)
	Commercial Umbrella Liability Policy Declarations	U-UMB-D-101-C CW (03/10)
	Schedule of Underlying Insurance	U-UMB-105-A CW (07/99)
	Extended Schedule of Underlying Insurance	U-UMB-106-A CW (07/99)
	Certified Act of Terrorism Exclusion - Coverages A& B	U-UMB-408-C MU (01/15)
	Care, Custody Or Control Exclusion	U-UMB-129-B CW (07/03)
	Contractors Limitation Endorsement With Consolidated (Wrap-Up) Insurance Program Excluded	U-UMB-134-D CW (01/14)
	Cross Suits Exclusion	U-UMB-141-A CW (07/99)
	Employee Benefits Liability Follow Form	U-UMB-167-B CW (07/03)
	Lead Exclusion	U-UMB-193-A CW (07/99)
	Products-Completed Operations Hazard Follow Form	U-UMB-224-A CW (07/99)
	Fungus or Bacteria Exclusion	U-UMB-385-C MU (07/19)
	Designated Work Exclusion	U-UMB-424-A CW (07/03)
	Silica or Silica Mixed Dust Exclusion	U-UMB-488-A CW (06/04)
	Total Pollution Exclusion	U-UMB-524-B CW (03/10)
	Access Or Disclosure Of Confidential Or Personal Information And Data-Related Liability Exclusion	U-UMB-920-A CW (01/15)
	Sanctions Exclusion Endorsement	U-GU-1191-A CW (03/15)
	Washington Changes	U-UMB-341-C WA (04/10)
Exclusion-Recording And Distribution Of Material Or Information In Violation Of Law	U-UMB-525-F CW (01/14)	
Umbrella Amendatory Endorsement	U-UMB-906-A CW (01/14)	

\* The titles of the endorsements are provided for convenience only. Coverage provided pursuant to these endorsements shall be interpreted and applied without regard to such titles.



STATE OF WASHINGTON

# BUSINESS LICENSE

Issue Date: Dec 15, 2023

Profit Corporation

Unified Business ID #: 328031141

Business ID #: 001

Location: 0002

Expires: Dec 31, 2024

SHAMROCK PAVING, INC.  
SHAMROCK PAVING INC.  
110 N HAYFORD RD  
SPOKANE WA 99224-9555

UNEMPLOYMENT INSURANCE - ACTIVE  
TAX REGISTRATION - ACTIVE

INDUSTRIAL INSURANCE - ACTIVE

CITY/COUNTY ENDORSEMENTS:

SPOKANE VALLEY GENERAL BUSINESS - NON-RESIDENT - ACTIVE

SPOKANE GENERAL BUSINESS - NON-RESIDENT #T12008193BUS - ACTIVE

LICENSING RESTRICTIONS:

Not licensed to hire minors without a Minor Work Permit.

REGISTERED TRADE NAMES:

SHAMROCK PAVING INC.

This document lists the registrations, endorsements, and licenses authorized for the business named above. By accepting this document, the licensee certifies the information on the application was complete, true, and accurate to the best of his or her knowledge, and that business will be conducted in compliance with all applicable Washington state, county, and city regulations.

Director, Department of Revenue

UBI: 328031141 001 0002

STATE OF WASHINGTON

Expires: Dec 31, 2024

SHAMROCK PAVING, INC.  
SHAMROCK PAVING INC.  
110 N HAYFORD RD  
SPOKANE WA 99224-9555

FOLD HERE

UNEMPLOYMENT INSURANCE - ACTIVE  
INDUSTRIAL INSURANCE - ACTIVE  
TAX REGISTRATION - ACTIVE  
SPOKANE VALLEY GENERAL BUSINESS - NON-RESIDENT - ACTIVE  
SPOKANE GENERAL BUSINESS - NON-RESIDENT #T12008193BUS - ACTIVE

FOLD HERE

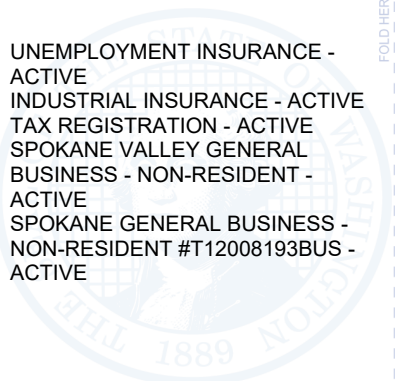

Director, Department of Revenue

## IMPORTANT!

### PLEASE READ THE FOLLOWING INFORMATION CAREFULLY BEFORE POSTING THIS LICENSE

#### General Information

Post this Business License in a visible location at your place of business.

If you were issued a Business License previously, **destroy the old one and post this one in its place.**

Login to My DOR at [dor.wa.gov](http://dor.wa.gov) if you need to make changes to your business name, location, mailing address, telephone number, or business ownership.

Telephone: 360-705-6741

#### Endorsements

All endorsements should be renewed by the expiration date that appears on the front of this license to avoid any late fees.

If there is no expiration date, the endorsements remain active as long as you continue required reporting. Tax Registration, Unemployment Insurance, and Industrial Insurance endorsements require you to submit periodic reports. Each agency will send you the necessary reporting forms and instructions.

For assistance or to request this document in an alternate format, visit <http://business.wa.gov/BLS> or call (360) 705-6741. Teletype (TTY) users may use the Washington Relay Service by calling 711.

BLS-700-107 (07/27/20)



**Agenda Sheet for City Council:**

**Committee:** Public Safety **Date:** 06/03/2024

**Committee Agenda type:** Discussion

<b>Date Rec'd</b>	5/29/2024
<b>Clerk's File #</b>	OPR 2024-0460
<b>Cross Ref #</b>	ORD C36527
<b>Project #</b>	

**Council Meeting Date:** 06/10/2024

<b>Submitting Dept</b>	FIRE	<b>Bid #</b>	
<b>Contact Name/Phone</b>	ANNE RAVEN (509)625-7091	<b>Requisition #</b>	
<b>Contact E-Mail</b>	ARAVEN@SPOKANECITY.ORG		
<b>Agenda Item Type</b>	Contract Item		
<b>Council Sponsor(s)</b>	PDILLON MCATHCART LNAVARRETE		
<b>Agenda Item Name</b>	CO-RESPONSE AGREEMENT AND EXPANSION		

**Agenda Wording**

Spokane Fire Department is requesting approval of agreement with the University of Washington towards the expansion of the Behavioral Response Unit program.

**Summary (Background)**

Spokane Fire is requesting approval of agreement with the University of WA towards the expansion of the Behavioral Response Unit program. Fire will provide services, and do all things necessary for or incidental to the performance work, as set forth in the Scope of Work. Upon completion of benchmark services, Fire will receive up to \$100,000 in 2024 and another \$100,000 in 2025. Special budget ordinance is requested to appropriate \$100,000 that will be used to procure two vehicles.

Lease? NO Grant related? NO Public Works? NO

**Fiscal Impact**

Approved in Current Year Budget? NO

Total Cost	\$ 100,000
Current Year Cost	\$ 100,000
Subsequent Year(s) Cost	\$ 100,000

**Narrative**

SFD will receive up to \$200,000 upon completion of benchmark deliverables as outlined in agreement.

**Amount**

**Budget Account**

Revenue	\$ 200,000	# 1970-35130-99999-34221-99999
Expense	\$ 100,000	# 1970-35130-94220-56404-99999
Expense	\$ 100,000	# 1970-35130-22200-VARIOUS
Select	\$	#
	\$	#
	\$	#



## Continuation of Wording, Summary, Approvals, and Distribution

### Agenda Wording

### Summary (Background)

#### **Approvals**

##### Dept Head

O'BERG, JULIE

##### Division Director

O'BERG, JULIE

##### Accounting Manager

SCHMITT, KEVIN

##### Legal

HARRINGTON,

##### For the Mayor

PICCOLO, MIKE

#### **Additional Approvals**

#### **Distribution List**

Silje Sodal croawa@gmail.com (signer)

Kevin Schmitt kschmitt@spokanecity.org

Fire Accounting fireaccounting@spokanecity.org

Anne Raven araven@spokanecity.org

Julie O'Berg joberg@spokanecity.org

Sue Raymon sraymon@spokanecity.org

## Council Briefing Paper

### Public Safety & Community Health Committee

<b>Committee Date</b>	June 3rd, 2024
<b>Submitting Department</b>	Fire
<b>Contact Name</b>	Anne Raven
<b>Contact Email &amp; Phone</b>	<a href="mailto:araven@spokanecity.org">araven@spokanecity.org</a> 625-7091
<b>Council Sponsor(s)</b>	Councilmembers Dillon, Cathcart & Navarrete
<b>Select Agenda Item Type</b>	<input checked="" type="checkbox"/> Discussion    Time Requested: 5min
<b>Agenda Item Name</b>	Special Budget Ordinance – Co-Response Agreement and Expansion
<b>Grant Item</b>	<input type="checkbox"/> Yes <input checked="" type="checkbox"/> No
<b>Proposed Council Action</b>	<input checked="" type="checkbox"/> Approval to proceed to Legislative Agenda
<b>Summary</b>  <b>What is the specific purpose or need for the budget adjustment?</b>  <b>What changes or developments have triggered this request?</b>	<p>The Spokane Fire Department is requesting approval of agreement with the University of Washington towards the expansion of the department's BRU program.</p> <p>SFD will provide services, and otherwise do all things necessary for or incidental to the performance work, as set forth in the Scope of Work. Upon completion of benchmark services, SFD will receive up to \$100,000 in 2024 and another \$100,000 in 2025.</p> <p>Special budget ordinance is requested to appropriate \$100,000 that will be used to procure two vehicles assigned to the BRU/CARES unit. Additional CARES members cannot perform their duties without assigned vehicles.</p>
<b>Fiscal Impact</b> <b>Approved in current year budget?</b> <input type="checkbox"/> Yes <input checked="" type="checkbox"/> No <input type="checkbox"/> N/A Total Cost: <u>\$100,000</u> Current year cost: \$100,000 Subsequent year(s) cost: \$100,000  <b>Funding Source</b> <input checked="" type="checkbox"/> One-time <input type="checkbox"/> Recurring <input type="checkbox"/> N/A Specify funding source: Program revenue Is this funding source sustainable for future years, months, etc? Yes – funds will be spent on one-time expenses  <b>Expense Occurrence</b> <input checked="" type="checkbox"/> One-time <input type="checkbox"/> Recurring <input type="checkbox"/> N/A  Other budget impacts: (revenue generating, match requirements, etc.)	
<b>Operations Impacts (If N/A, please give a brief description as to why)</b>  <ul style="list-style-type: none"> <li>• What are the net impacts this adjustment will have on the specifically affected line items? <i>Net zero impact on the Fire/EMS fund as the department will receive \$100,000 in currently unbudgeted revenues.</i></li> <li>• What operational changes will occur because of this adjustment?</li> </ul>	



*Expansion of the BRU/CARES unit in the Spokane Fire Department*

- What are the potential risks or consequences of not approving the budget adjustment?

*New personnel would be without transportation and be unable do homeless outreach, home visits, substance use disorder outreach, meeting with stakeholders, community education and public engagement opportunities.*

- Describe how this proposal aligns with current City Policies, including the Comprehensive Plan, Sustainability Action Plan, Capital Improvement Program, Neighborhood Master Plans, Council Resolutions, and others?

*Aligns with the plans to address the opioid use disorder, homelessness, and provide services to other vulnerable populations in our community.*

**What current racial and other inequities might this special budget ordinance address?**

***The CARES Teams need updated vehicles to be operational. The focus of the work at CARES is to address the inequities that the most vulnerable people in Spokane face. The team addresses the barriers people encounter when trying to access services. Finding the right services and resources that are culturally appropriate and respectful is central to the goals of CARES.***

# **W** UNIVERSITY of WASHINGTON

Procurement Services  
Roosevelt Commons West  
4300 Roosevelt Way 3<sup>rd</sup> Fl  
Box 354966  
Seattle, WA 98105

## **Services Agreement**

This Services Agreement, referred to as "Agreement", is effective as of May 1, 2024 ("Effective Date") by and between the University of Washington, an institution of public higher education, located in Seattle, Washington, hereinafter referred to as "University", and City of Spokane Fire Department ("Contractor"). This Agreement specifies the Terms and Conditions of Contractor's relationship with the University.

In consideration of the mutual premises hereinafter contained, the parties agree that this contract will be performed in accordance with the following conditions:

### 1. PURPOSE

In 2023, the State Legislature appropriated funds to provide funding for mental health professionals to provide regional behavioral health services in the field for non-law enforcement-based co-response programs. Within these programs, regional 'pilot' training HUBs will be created for the purpose of training non-law enforcement-based emergency response personnel, including Fire/EMTs, community paramedics, and co-responders who are responding to behavioral health emergencies.

Funding must be used by the Contractor to create or sustain a co-response program working in one of the following innovation areas: becoming a behavioral health agency and billing for behavioral health services; starting/expanding the administration of medications for opioid use disorder in the field; operating a crisis response or follow-up response unit that is integrated into the 988/local crisis hub system; or starting a program in a critical shortage area not being served by any co-response services. Funding must also be used to support train-the-trainer opportunities and training activities in 2025.

### 2. SCOPE OF WORK

#### 2.1 Performance

The Contractor will provide services, and otherwise do all things necessary for or incidental to the performance of work, as set forth in the Scope of Work dated 5/1/24 and incorporated herein. Performances include:

#### Demographic Reporting (May 2024-June 2025)

The Contractor will collect and report demographic information of individuals served on a quarterly basis and include the following information: age, race/ethnicity, gender, sex, marital status, and military service. The University of Washington will provide a demographic reporting spreadsheet along with other reporting requirements.

## Deliverables and Compensation

Total compensation payable to the Contractor for satisfactory performance of work is up to a maximum of \$200,000, including expenses as described in the University of Washington/CROA Grant Review Committee Grant Award letter addressed to Ms. Anne Raven, City of Spokane Fire Department, Integrated Medical Services Manager, which is attached hereto as an Exhibit. Additional funding may be available for training activities. Invoices must describe and document, to the University of Washington's satisfaction, a description of benchmarks met. The Contractor will invoice the University of Washington upon completion of benchmark deliverables in accordance with the benchmark table below.

### 2.2 Reports

The Contractor shall produce the following written reports or other written documents (deliverables) by project team agreed timelines:

**BENCHMARK TABLE**

Benchmark Number	Description	Due Date	Payable Amount Upon Completion of Satisfactory Deliverable
<b>1</b>	Project Plan signed by a Chief, Medical Director, key personnel and key agency partner(s). Plan must include a description of co-response program and how program will compliment new overdose prevention initiative. Plan must include different overdose prevention strategies (including but not limited to administration of medications in the field), staffing model, information sharing strategies, and a flowchart showing how an individual will receive services after a call for service is received. Plan must also include project benchmarks organized by quarter.	<b>May 31, 2024</b>	<b>\$20,000</b>
<b>2</b>	Budget summary submitted. Must include: - Costs of operating program from May 2024-June 2025 by general line-item categories (costs must be related to co-response program and/or innovation area); - Estimated costs of sending two Firefighters/EMTs to a 2 Day Train-the-Trainer Exercise at the UW in Spring 2025; and - Costs of hosting two 8 Hour Trainings in Behavioral Health Response in 2025.	<b>May 31, 2024</b>	<b>\$20,000</b>

# W UNIVERSITY of WASHINGTON

<b>3</b>	Participation in First Cohort Meeting with a minimum of one other Innovation Grant Department. Submit the date of the meeting, plan for follow-up meetings, and attendee list.	<b>May 31, 2024</b>	<b>\$15,000</b>
<b>4</b>	Policies/procedures related to MOUD administration provided to CROA/UW for posting on website to promote best/promising practices.	<b>May 31, 2024</b>	<b>\$15,000</b>
<b>5</b>	Participation in Police Department/Fire Department meeting to promote a coordinated approach to overdose prevention. Submit date of meeting, attendees, and goals for 2024.	<b>June 15, 2024</b>	<b>\$15,000</b>
<b>6</b>	Participation in meeting with hospital/healthcare providers to discuss medical clearance in the field; submit date of meeting, meeting agenda, attendee list, and goals established for group related to medical clearance.	<b>June 15, 2024</b>	<b>\$15,000</b>
		<b>First Invoice 6/15</b>	<b>up to \$100,000</b>
<b>7</b>	Quarterly Status Report 1 & Data Summary Submitted (May-July) <i>(Note: Reporting Form will be Submitted by UW by June 1, 2024)</i>	<b>August 15, 2024</b>	<b>\$5,000</b>
<b>8</b>	Quarterly Check in with CROA/UW Team to Discuss Q1 Report.	<b>September 15, 2024</b>	<b>\$5,000</b>
<b>9</b>	Quarterly Status Report 2 & Data Summary Submitted (Aug.-Oct.)	<b>November 15, 2024</b>	<b>\$5,000</b>
<b>10</b>	Quarterly Check in with CROA/UW Team to Discuss Q2 Report.	<b>December 15, 2024</b>	<b>\$5,000</b>
<b>11</b>	Participation in second Police Department/Fire Department meeting to promote a coordinated approach to overdose prevention. Submit date of meeting, attendees, and goals for 2025.	<b>January 31, 2025</b>	<b>\$10,000</b>
<b>12</b>	First Draft of Toolkit submitted.	<b>February 15, 2025</b>	<b>\$10,000</b>
<b>13</b>	Quarterly Status Report 3 & Data Summary Submitted (Nov.-Jan.)	<b>February 15, 2025</b>	<b>\$5,000</b>

# UNIVERSITY of WASHINGTON

<b>14</b>	Quarterly Check in with CORA/UW Team to Discuss Q3 Report.	<b>March 15, 2025</b>	<b>\$5,000</b>
		<b>Second invoice 3/15</b>	<i>up to \$50,000</i>
<b>15</b>	Final/Annual Status Report & Data Summary Submitted (June 2024-May 2025)	<b>June 15, 2025</b>	<b>\$5,000</b>
<b>16</b>	Meeting with all Innovation Grant Recipients to discuss Final/Annual Reports.	<b>June 30, 2025</b>	<b>\$5,000</b>
<b>17</b>	Final Toolkit submitted.	<b>June 30, 2025</b>	<b>\$10,000</b>
<b>18</b>	Department attendance and/or participation at 2025 CROA Conference.	<b>Spring 2025</b>	<b>\$5,000</b>
<b>19</b>	Minimum of two Firefighters/EMTs/Medics participate in 2 Day Train-the-Trainer Class at UW.	<b>Spring 2025</b>	<b>\$5,000</b>
<b>20</b>	Department holds first 8-Hour Training in Behavioral Health Response.	<b>Spring 2025</b>	<b>\$10,000</b>
<b>21</b>	Department schedules second 8-Hour Training in Behavioral Health Response.	<b>June 30, 2025</b>	<b>\$10,000</b>
		<b>Third Invoice 6/30</b>	<i>up to \$50,000</i>

All written reports required under this contract must be delivered to Dr. Jennifer Stuber, the Project Director, and Kim Hendrickson, the Fire Department Innovation Grants Program Manager, in accordance with the schedule above.

### 3. PERIOD OF PERFORMANCE

The period of performance under this contract will be from 5/1/24 through 6/30/25. The University of Washington reserves the right to extend this contract but shall be under no obligation to do so.

### 4. AMENDMENTS

The parties may change the scope of the Services and Deliverables and other matters specified in a Scope of Work only by a written amendment executed in advance by an authorized representative of each party and incorporated into the Agreement as an amendment.

# **W** UNIVERSITY of WASHINGTON

## 5. INDEPENDENT CONTRACTOR

The parties intend that an independent contractor relationship is created by this Contract. The Contractor and his or her employees or agents performing under this Contract are not employees or agents of the UW. The Contractor, his or her employees, or agents performing under this Contract will not hold himself/herself out as, nor claim to be, an officer or employee of the UW or of the State of Washington by reason hereof, or act as attorney in fact, nor will the Contractor make any claim of right, privilege or benefit that would accrue to such employee. Conduct and control of the work will be solely with the Contractor.

## 6. RESPONSIBILITIES AND EVALUATION UNDER SCOPE OF WORK

The Contractor shall be responsible for completing all requirements in the Scope of Work. Other than as reasonably required to ensure that adequate and timely progress is made under this Agreement, the parties intend that in accomplishing the requirements set forth in the Scope of Work, Contractor shall be responsible for using its discretion in determining the appropriate employees to assign to the completion of the work thereunder, the schedules and locations of such employees, and the order in which work is performed.

In no event shall UW be responsible for providing training to the Contractor or its staff or be required to provide instruction regarding the completion of deliverables included in the Scope of Work.

The Contractor's satisfactory performance under this Agreement shall be measured by the content of deliverables provided under the Scope of Work. The process of developing such deliverables shall be in the discretion of Contractor.

## 7. COMPENSATION

Total compensation payable to the Contractor for satisfactory performance of the work under this contract shall not exceed two hundred thousand dollars and 00 cents (\$200,000), including expenses. The Contractor's compensation for services rendered shall be based on the following rates or in accordance with the following terms:

7.1 During the term of this Agreement, University will pay the Contractor for deliverables completed, as outlined in the Benchmark table above.

7.2 All taxes or fees assessed by any tax jurisdiction arising from the Projects outside of the U.S. are the responsibility of the University.

### 7.3 Expenses

The Contractor shall not receive additional reimbursement for travel nor other expenses. Payment for expenses shall be included in the total compensation stated above in the Benchmarks Table.

## 8. BILLING PROCEDURES AND PAYMENT

### 8.1 Invoicing

UW will pay the Contractor upon acceptance of services provided and receipt of properly completed invoices. Payment is contingent upon review and acceptance by the UW of the Contractor's services. The University utilizes Workday as its financial system. Purchase

# W UNIVERSITY of WASHINGTON

orders will be emailed via Workday. Contractor shall submit invoices as a PDF referencing the purchase order # to [uwashington@ghxinvoicing.com](mailto:uwashington@ghxinvoicing.com).

For additional information: <https://finance.uw.edu/ps/suppliers>

## 8.2 Payment Date

Payment shall be considered timely if made by the UW within thirty (30) calendar days after receipt of properly completed invoices. Payment shall be sent to the address designated by the Contractor.

## 9. CONFIDENTIAL INFORMATION

“Confidential Information” means any non-public information of University which is maintained as confidential, including, but not limited to, biological materials; software; diagrams; valuable formulae; electronic files; source code; physical files; invention disclosures; patent applications; technical and scientific information; research data; draft publications; technical reports; research plans; research discoveries; business plans; financial reports, projections, and/or models; educational records; and Personally Identifiable Information (PII). Confidential Information does not include any information which Contractor can establish by competent written proof (a) was in the public domain as of the Effective Date; or (b) was independently developed by Contractor without knowledge of or assistance from the Confidential Information.

**The obligations with respect to Confidential Information set forth in this Section shall survive the termination of this agreement.**

## 10. CONFLICT OF INTEREST

Notwithstanding any determination by the Executive Ethics Board or other tribunal, the UW may, in its sole discretion, by written notice to the Contractor terminate this Contract if it is found after due notice and examination by the UW that there is a violation of the Ethics in Public Service Act, Chapter 42.52 RCW, or any similar statute involving the Contractor in the procurement of this Contract, or the provision of goods or services under this Contract.

If this Contract is terminated as provided above, the UW shall be entitled to pursue the same remedies against the Contractor as it could pursue in the event of a breach of this Contract by the Contractor. The rights and remedies of the UW provided for in this clause shall not be exclusive and are in addition to any other rights and remedies provided by law.

## 11. COPYRIGHT AND INTELLECTUAL PROPERTY PROVISIONS

Unless otherwise provided, all Materials produced under this Contract shall be considered "works for hire" as defined by the U.S. Copyright Act and shall be owned by the UW. The UW shall be considered the author of such Materials. If the Materials are not considered "works for hire" under the U.S. Copyright laws, the Contractor hereby irrevocably assigns all right, title, and interest in Materials, including all intellectual property rights, to the UW effective from the moment of creation of such Materials. For Materials that are delivered under this Contract, but that incorporate pre-existing materials not produced under this Contract, the Contractor grants to the UW a nonexclusive, royalty-free, irrevocable license (with rights to sublicense others) in such Materials to translate, reproduce, distribute, prepare derivative works, publicly perform, and publicly display. The Contractor warrants and represents that the Contractor has all rights and permissions, including intellectual property rights, moral rights, and rights of publicity, necessary to grant such a license to the UW.

The UW shall receive prompt written notice of each notice or claim of copyright infringement received by the Contractor with respect to any Materials delivered under this Contract. The UW

# W UNIVERSITY of WASHINGTON

shall have the right to modify or remove any restrictive markings placed upon the Materials by the Contractor. Both the University and Contractor recognize that they are subject to the legal obligations of the Washington State Public Records Act, RCW 42.56 et. seq.

## 12. NOTICES

- 12.1 The Project Director (Section 2.2) and Contract Manager (below) for each of the parties shall be the contact person for all communications and billings regarding the performance of this contract.
- 12.2 Any notices required under this contract shall be sent in writing to the appropriate Contract Manager via U.S. Mail or email.

Contract Manager for CONTRACTOR is:	Contract Manager for UW is:
<p><i>Contract Manager Name:</i></p> <p>Anne Raven Integrated Medical Services Manager City of Spokane 1610 N Rebecca Street Spokane WA 99217-7200</p> <p>Phone: 509-435-7091 Email: araven@spokanecity.org</p>	<p><i>Contract Manager Name:</i></p> <p>Alyssa Camp University of Washington School of Social Work Box 354900 4101 15<sup>th</sup> Ave. NE Seattle, WA 98105</p> <p>Phone: (206)-<u>543-9817</u>Fax: (206)-<u>543-3204</u> E-mail address: <u>Acamp1@uw.edu</u></p> <p><i>Purchasing Agent</i></p> <p>Dawn Lake <u>dawnlake@uw.edu</u></p>

## 13. TERMINATION

- 13.1 This contract may be terminated by either party for convenience in accordance with UW Terms and Conditions, #8c, *Termination for Convenience*, terminated for breach in accordance with UW Terms and Conditions, #8d, *Termination for Breach*, terminated due to change in funding with UW Terms and Conditions, #8e, *Termination Due to Change in Funding*, or terminated by mutual agreement, 8f *Termination by Mutual Agreement*. Termination procedures shall be handled in accordance with UW Terms and Conditions #38 *Termination Procedures*. UW Terms and Conditions are available at: [https://finance.uw.edu/ps/sites/default/files/purchasing/terms-and-conditions/UW%20General%20Terms%20and%20Conditions%20-%202-2024\\_cc\\_0.pdf](https://finance.uw.edu/ps/sites/default/files/purchasing/terms-and-conditions/UW%20General%20Terms%20and%20Conditions%20-%202-2024_cc_0.pdf)
- 13.2 The UW may, in its sole discretion, terminate the contract or withhold payments claimed by the Contractor for services rendered if the Contractor fails to satisfactorily comply with any term or condition of this contract. No payments in advance or in anticipation of services or supplies to be provided under this contract shall be made by the UW.



14. ASSURANCES

UW and the Contractor agree that all activity pursuant to this contract will be in accordance with all the applicable current federal, state and local laws, rules, and regulations.

15. ORDER OF PRECEDENCE

Each of the documents listed below is hereby incorporated into this contract. In the event of a conflict between these documents, the conflict shall be resolved by giving precedence in the following order:

- This contract and attachments
- UW General Terms and Conditions
- Applicable Federal and State of Washington statutes and regulations

16. ENTIRE AGREEMENT

This contract, consisting of the documents described in the “Order of Precedence” section above, represents all the terms and conditions agreed upon by the parties. No other statements or representations, written or oral, shall be deemed a part hereof.

17. SEVERABILITY

The provisions of this contract are intended to be severable. If any term or provision is illegal or invalid for any reason whatsoever, such illegality or invalidity shall not affect the validity of the remainder of the contract.

18. APPROVAL

This contract shall be subject to the written approval of the UW'S authorized representative and shall not be binding until so approved. The contract may be altered, amended, or waived only by a written amendment.

This agreement is executed by the persons signing below, who warrant they have the authority to execute the contract.

**CITY OF SPOKANE FIRE DEPARTMENT**

**UNIVERSITY OF WASHINGTON**

\_\_\_\_\_  
Signature

\_\_\_\_\_  
Signature

\_\_\_\_\_  
Title

\_\_\_\_\_  
Date

\_\_\_\_\_  
Title

\_\_\_\_\_  
Date



Co-Responder Outreach Alliance &lt;croawa@gmail.com&gt;

## Congratulations

1 message

**Co-Responder Outreach Alliance** <croawa@gmail.com>  
To: "Raven, Anne" <araven@spokanecity.org>  
Bcc: Co-Responder Outreach Alliance <croawa@gmail.com>

Mon, Mar 25, 2024 at 8:43 PM

Dear Ms. Raven,

Congratulations!

You have been selected as a recipient for the Fire Department Co-Response Innovation Grant. Your department will receive \$200,000 to develop and implement the following innovation strategy: *Starting/expanding the administration of medications for opioid use disorder in the field*. More information and details on next steps will be sent shortly. In the meantime, please contact Silje Sodal at [croawa@gmail.com](mailto:croawa@gmail.com) if you have any questions.

Again, congratulations, and thank you for your interest in expanding co-response in your district and throughout Washington.

Sincerely,

University of Washington/CROA Grant Review Committee:

Dr. Marc Bellis  
MPD, Bellevue Fire Medic One  
Eastside Fire & Rescue C.O.R.E.

David J. Busz  
Fire Chief, City of Montesano

Chuck DeSmith  
Deputy Chief of EMS/Safety  
Renton Regional Fire Authority

Dawn Felt, NRP, MPA  
Acting EMS Program Manager  
EMS Education & Training Consultant  
Emergency Care System  
Health Systems Quality Assurance  
Washington State Department of Health

Kim Hendrickson  
Program Manager  
CROA Fire Department Innovation Grants

Vanessa Martin  
Managing Director, CROA

Jennifer Stuber, Ph.D.  
Assoc. Professor, UW School of Social Work  
SMART Center Core Faculty  
Co-Founder Forefront Suicide Prevention

--

---

Silje Sodal  
Special Projects Lead  
CROA  
[croawa@gmail.com](mailto:croawa@gmail.com)

<https://croawa.com/>

---



**Agenda Sheet for City Council:**

**Committee:** Finance & Administration **Date:** 06/03/2024

**Committee Agenda type:** Consent

**Date Rec'd**

5/29/2024

**Clerk's File #**

OPR 2024-0461

**Cross Ref #**

**Project #**

**Council Meeting Date:** 06/10/2024

**Submitting Dept**

CITY ATTORNEY

**Bid #**

**Contact Name/Phone**

MICHAEL 6283

**Requisition #**

CR26367 (2024)

**Contact E-Mail**

MPICCOLO@SPOKANECITY.ORG

**Agenda Item Type**

Contract Item

**Council Sponsor(s)**

MCATHCART BWILKERSON ZZAPPONE

**Agenda Item Name**

0500 WESTLAW LEGAL RESEARCH CONTRACT

**Agenda Wording**

A contract with Thomson Reuters for Westlaw Legal Research. This is a five year term with a 1% increase per year beginning July 1, 2024 through June 30, 2029. Total contract amount \$324,424.08, excluding tax. Funds will be encumbered annually.

**Summary (Background)**

A contract with Thomson Reuters for Westlaw Legal Research Licenses for City Legal, City Prosecutor, the Hearing Examiner, City Council and the Office of Police Ombudsman.

Lease? NO Grant related? NO Public Works? NO

**Fiscal Impact**

Approved in Current Year Budget? YES

Total Cost \$ 353,622.25 including sales tax

Current Year Cost \$ \$69,324.00

Subsequent Year(s) Cost \$ \$284,298.25

**Narrative**

The fifth year's cost is \$72,138.95 (July 2028-June 2029). Sales tax is estimated at 9.00%.

**Amount**

**Budget Account**

Expense \$ 69,324.00 # 0500-33200-15300-53102 (July 2024-June 2025)

Expense \$ \$70,017.24 # 0500-33200-15300-53102 (July 2025-June 2026)

Expense \$ \$70,717.41 # 0500-33200-15300-53102 (July 2026-June 2027)

Expense \$ \$71,424.65 # 0500-33200-15300-53102 (July 2027-June 2028)

\$ #

\$ #



## Continuation of Wording, Summary, Approvals, and Distribution

### Agenda Wording

### Summary (Background)

#### **Approvals**

##### Dept Head

PICCOLO, MIKE

##### Division Director

##### Accounting Manager

BUSTOS, KIM

##### Legal

HARRINGTON,

##### For the Mayor

PICCOLO, MIKE

#### **Additional Approvals**

#### **Distribution List**

eddie.repanich@thomsonreuters.com

Dan.Nagan@thomsonreuters.com

ywang@spokanecity.org

sdhansen@spokanecity.org

hhaws@spokanecity.org

## Committee Agenda Sheet

### Finance & Administration Committee

<b>Committee Date</b>	June 3, 2024
<b>Submitting Department</b>	Legal
<b>Contact Name</b>	Mike Piccolo
<b>Contact Email &amp; Phone</b>	<a href="mailto:mpiccolo@spokanecity.org">mpiccolo@spokanecity.org</a> ; 625-6237
<b>Council Sponsor(s)</b>	<u>CM Cathcart, CP Wilkerson, CM Zappone</u>
<b>Select Agenda Item Type</b>	<input checked="" type="checkbox"/> Consent <input type="checkbox"/> Discussion    Time Requested:
<b>Agenda Item Name</b>	Westlaw Legal Research Contract
<b>Proposed Council Action</b>	<input checked="" type="checkbox"/> Approval to proceed to Legislative Agenda <input type="checkbox"/> Information Only
<b>Summary (Background)</b>	A contract with Thomson Reuters for Westlaw Legal Research Licenses for City Legal, City Prosecutor, the Hearing Examiner, City Council and the Office of Police Ombudsman. This is a five year term with a 1% increase per year. Total contract amount \$324,424.08, excluding tax.
<p><b>Fiscal Impact</b></p> <p><b>Approved in current year budget?</b>    <input checked="" type="checkbox"/> Yes    <input type="checkbox"/> No    <input type="checkbox"/> N/A</p> <p>Total Cost: <u>\$324,424.08</u></p> <p>Current year cost:</p> <p>Subsequent year(s) cost:</p> <p><b>Narrative:</b> <u>N/a</u></p> <p><b>Funding Source</b>    <input type="checkbox"/> One-time    <input checked="" type="checkbox"/> Recurring    <input type="checkbox"/> N/A</p> <p>Specify funding source: Select Funding Source*</p> <p>Is this funding source sustainable for future years, months, etc? This comes from Legal's Publication budget.</p> <p><b>Expense Occurrence</b>    <input type="checkbox"/> One-time    <input checked="" type="checkbox"/> Recurring    <input type="checkbox"/> N/A</p> <p>Other budget impacts: (revenue generating, match requirements, etc.)</p>	
<b>Operations Impacts (If N/A, please give a brief description as to why)</b>	
What impacts would the proposal have on historically excluded communities? <u>N/A</u>	
How will data be collected, analyzed, and reported concerning the effect of the program/policy by racial, ethnic, gender identity, national origin, income level, disability, sexual orientation, or other existing disparities? <u>N/A</u>	
How will data be collected regarding the effectiveness of this program, policy or product to ensure it is the right solution? <u>N/A</u>	

Describe how this proposal aligns with current City Policies, including the Comprehensive Plan, Sustainability Action Plan, Capital Improvement Program, Neighborhood Master Plans, Council Resolutions, and others?  
N/A



**Order Form**

**Order ID: Q-08414254**

Contact your representative [dan.nagan@thomsonreuters.com](mailto:dan.nagan@thomsonreuters.com) with any questions. Thank you.

**Sold To Account Address**

Account #: 1000717818  
 SPOKANE  
 CITY ATTORNEY  
 808 W SPOKANE FALLS BLVD FL 5  
 SPOKANE WA 99201-3333 US  
 "Customer"

**Shipping Address**

Account #: 1000717818  
 SPOKANE  
 CITY ATTORNEY  
 808 W SPOKANE FALLS BLVD FL 5  
 SPOKANE WA 99201-3333 US

**Billing Address**

Account #: 1000717818  
 SPOKANE  
 CITY ATTORNEY  
 808 W SPOKANE FALLS BLVD FL 5  
 SPOKANE, WA 99201-3333  
 US

This Order Form is a legal document between Customer and

- A. West Publishing Corporation to the extent that products or services will be provided by West Publishing Corporation, and/or
- B. Thomson Reuters Enterprise Centre GmbH to the extent that products or services will be provided by Thomson Reuters Enterprise Centre GmbH.

A detailed list of products and services that are provided by Thomson Reuters Enterprise Centre GmbH and current applicable IRS Certification forms are available at: <https://www.tr.com/trorderinginfo>

West Publishing Corporation may also act as an agent on behalf of Thomson Reuters Enterprise Centre GmbH solely with respect to billing and collecting payment from Customer. Thomson Reuters Enterprise Centre GmbH and West Publishing Corporation will be referred to as "Thomson Reuters", "we" or "our," in each case with respect to the products and services it is providing, and Customer will be referred to as "you", or "your" or "Client".

For Federal Customers the following shall apply: Thomson Reuters General Terms and Conditions (available here: <http://tr.com/federal-general-terms-and-conditions>) apply to the purchase and use of all products, except print, and together with any applicable Product Specific Terms (set forth below) are incorporated into this Order Form by this reference. In the event that there is a conflict of terms among the General Terms and Conditions, the Product Specific Terms and this Order Form, the order of precedence shall be Order Form, the Product Specific Terms, and last the General Terms and Conditions.

For non-federal customers the following shall apply: Thomson Reuters General Terms and Conditions (<http://tr.com/us-general-terms-and-conditions>) apply to the purchase and use of all products, except print, and together with any applicable Product Specific Terms (set forth below) are incorporated into this Order Form by this reference. In the event that there is a conflict of terms among the General Terms and Conditions, the Product Specific Terms and this Order Form, the order of precedence shall be Order Form, the Product Specific Terms, and last the General Terms and Conditions.

**ProFlex Products**  
 See Attachment for details

Material #	Product	Monthly Charges	Minimum Terms (Months)
40757482	West Proflex	\$5,300.00	60

**Bridge Products**

Material #	Product	Quantity	Unit	Bridge Monthly Charges	Bridge Term (Months)
40757482	West Proflex	1	Each	\$4,417.78	1

**Bridge Terms**

Bridge Monthly Charges begin on the date we process your order and will be prorated for the number of days remaining in the calendar month, if any. The Bridge Monthly charges will continue for the number of complete calendar months listed in the Bridge Term column above and will be in addition to the Monthly Charges and Minimum Term outlined above. At the end of the Bridge Term, your Monthly Charges and the Minimum term will begin on the first full calendar month following the Bridge Term as described in the Product grid above. All other terms and conditions of the Order Form remain unchanged. For purposes of clarification, your total Term will be the Bridge Term plus the Minimum Term.

**Minimum Terms**

Your subscription is effective upon the date we process your order ("Effective Date") and Monthly Charges will be prorated for the number of days remaining in that month, if any. Your subscription will continue for the number of months listed in the Minimum Term column above plus any Bridge Term that may be outlined above counting from the first day of the month following the Effective Date. Your Monthly Charges during the first twelve (12) months of the Minimum Term are as set forth above. If your Minimum Term is longer than 12 months, then your Monthly Charges for each year of the Minimum Term are displayed in the Attachment to the Order Form.

**Post Minimum Terms**

Your subscription will automatically renew at the end of the Minimum Term. Each Automatic Renewal Term will be 12 months in length ("Automatic Renewal Term"), and we will notify you of any change in the Monthly Charges at least 60 days before each Automatic Renewal Term starts. You are also responsible for all Excluded Charges.



Federal government subscribers that chose a multi-year Minimum Term, those additional years will be implemented at your option pursuant to federal law. Either of us may cancel the Automatic Renewal Term by sending notice in writing at least 30 days before an Automatic Renewal Term begins. Send your notice of cancellation to Customer Service, 610 Opperman Drive., P.O. Box 64833, Eagan, MN 55123-1803.

**Banded Product Subscriptions.** You certify your total number of attorneys (full-time and part-time partners, shareholders, associates, contract or staff attorneys, of counsel, and the like), corporate users, personnel or full-time-equivalent students is indicated in this Order Form. Our pricing for banded products is made in reliance upon your certification. If we learn that the actual number is greater or increases at any time, we reserve the right to increase your charges to the market rate for all of your attorneys.

#### Miscellaneous

**Applicable Law.** If you are a state or local governmental entity, your state's law will apply, and any claim may be brought in the state or federal courts located in your state. If you are a non-governmental entity, this Order Form shall be interpreted under Minnesota state law and any claim by one of us shall exclusively be brought in the state or federal courts in Minnesota. If you are a United States Federal Government subscriber, United States federal law will apply, and any claim may be brought in any federal court.

**Material Change.** If, at any time during the Minimum Term or the Renewal Term, there is a material change in your organizational structure including, but not limited to merger, acquisitions, combination, significant increase in the number of attorneys at a location covered by the agreement, divestitures, downsizing or dissolution, the parties agree to immediate good faith renegotiation of the terms and conditions of this ordering document, during which we may modify your rates proportionally. If you acquire the assets of, or attorneys from, another entity that is a current subscriber, you assume all obligations under the agreements that apply to those assets and attorneys, and you will pay the invoiced charges on both those agreements as they become due, until a superseding agreement is negotiated in good faith.

**Charges, Payments & Taxes.** You agree to pay all charges in full within 30 days of the date of invoice. You are responsible for any applicable sales, use, value added tax (VAT), etc. unless you are tax exempt. If you are a non-government customer and fail to pay your invoiced charges, you are responsible for collection costs including attorneys' fees.

**Excluded Charges And Schedule A Rates.** If you access products or services that are not included in your subscription you will be charged our then-current rate ("Excluded Charges"). Excluded Charges will be invoiced and due with your next payment. For your reference, the current Excluded Charges schedules are located in the below link. Excluded Charges may change from time-to-time upon 30 days written or online notice. We may, at our option, make certain products and services Excluded Charges if we are contractually bound or otherwise required to do so by a third party provider or if products or services are enhanced or if new products or services are released after the effective date of this ordering document. Modification of Excluded Charges or Schedule A rates is not a basis for termination under paragraph 9 the General Terms and Conditions.

<https://legal.thomsonreuters.com/content/dam/ewp-m/documents/legal/en/pdf/other/plan-2-pro-govt-agencies.pdf>  
<http://static.legalsolutions.thomsonreuters.com/static/agreement/plan-2-pro-govt-agencies.pdf>

**eBilling Contact.** All invoices for this account will be emailed to your e-Billing Contact(s) unless you have notified us that you would like to be exempt from e-Billing.

**Credit Verification.** If you are applying for credit as an individual, we may request a consumer credit report to determine your creditworthiness. If we obtain a consumer credit report, you may request the name, address and telephone number of the agency that supplied the credit report. If you are applying for credit on behalf of a business, we may request a current business financial statement from you to consider your request.

**Cancellation Notification Address.** Send your notice of cancellation to Customer Service, 610 Opperman Drive, P.O. Box 64833, Eagan MN 55123-1803

**Returns and Refunds.** You may return a print product to us within 45 days of the original shipment date if you are not completely satisfied. Please see <http://static.legalsolutions.thomsonreuters.com/static/returns-refunds.pdf> or contact Customer Service at 1-800-328-4880 for additional details regarding our policies on returns and refunds.

**Document Intelligence Product Specific Terms:** The following product specific terms shall apply to the Document Intelligence products on this order form, and are incorporated by reference: <http://www.thomsonreuters.com/document-intelligence-PST>.

**Product Specific Terms and Service Levels:** The following product specific terms and service levels shall apply to the HighQ products on this order form, and are incorporated by reference:

- HighQ Product Specific Terms <http://tr.com/HighQ-PST>
- HighQ Service Levels: Thomson Reuters shall provide service availability, maintenance and support for the term of the Agreement. Details are available at: <http://tr.com/HighQ-SLA>. Note that Sections 3.3 of the SLA does not apply to any HighQ Light packages

**Product Specific Terms.** The following products have specific terms which are incorporated by reference and made part of this Order Form if they apply to your order. They can be found at <https://static.legalsolutions.thomsonreuters.com/static/ThomsonReuters-General-Terms-Conditions-PST.pdf>. If the product is not part of your order, the product specific terms do not apply. If there is a conflict between product specific terms and the Order Form, the product specific terms control.

- Campus Research
- Hosted Practice Solutions
- ProView eBooks
- Time and Billing
- West km Software
- West LegalEdcenter
- Westlaw
- Westlaw Doc & Form Builder
- Westlaw Paralegal
- Westlaw Patron Access
- Westlaw Public Records

**Drafting Tools Product Specific Terms:** The following product specific terms shall apply to the Drafting Tools products (Drafting Assistant, Clause Finder, Clause Finder: Internal Agreements) on this order form, and are incorporated by reference: <http://tr.com/drafting-tools-product-specific-terms>.

The Federal Product Specific Terms can be found here: <http://tr.com/federal-product-specific-terms>

**Amended Terms and Conditions**

**Government Non-Availability of Funds for Online, Practice Solutions or Software Products**

You may cancel a product or service with at least 30 days written notice if you do not receive sufficient appropriation of funds. Your notice must include an official document, (e.g., executive order, an officially printed budget or other official government communication) certifying the non-availability of funds. You will be invoiced for all charges incurred up to the effective date of the cancellation.

**Acknowledgement: Order ID: Q-08414254**

\_\_\_\_\_  
**Signature of Authorized Representative for order**

\_\_\_\_\_  
**Title**

\_\_\_\_\_  
**Printed Name**

\_\_\_\_\_  
**Date**

This Order Form will expire and will not be accepted after 6/25/2024.



# Attachment

# Order ID: Q-08414254

Contact your representative dan.nagan@thomsonreuters.com with any questions. Thank you.

### Payment, Shipping, and Contact Information

**Payment Method:**

Payment Method: Bill to Account  
 Account Number: 1000717818  
 This order is made pursuant to:

**Order Confirmation Contact (#28)**

Contact Name: Hansen, Sheila  
 Email: sdhansen@spokanecity.org

**eBilling Contact**

Contact Name Sheila Hansen  
 Email sdhansen@spokanecity.org

**Shipping Information:**

Shipping Method: Ground Shipping - U.S. Only

### ProFlex Multiple Location Details

Account Number	Account Name	Account Address	Action
1000717818	SPOKANE	808 W SPOKANE FALLS BLVD FL 5 SPOKANE WA 99201-3333 US	New

### ProFlex Product Details

Quantity	Unit	Service Material #	Description
1	Each	40757482	West Proflex
25	Attorneys	43102993	Westlaw Precision Preferred with AI-Assisted Research National Primary Law, Enterprise access, Government
25	Attorneys	42077755	Westlaw All Analytical, Enterprise access, Government

### Account Contacts

Account Contact First Name	Account Contact Last Name	Account Contact Email Address	Account Contact Customer Type Description
Sheila	Hansen	sdhansen@spokanecity.org	EML PSWD CONTACT

### Lapsed Products

Sub Material	Active Subscription to be Lapsed
40757481	West Proflex

### Charges During Minimum Term

Material #	Product Name	Year 1 Charges per Billing Freq	% incr Yr 1-2*	Year 2 Charges per Billing Freq	% incr Yr 2-3*	Year 3 Charges per Billing Freq	% incr Yr 3-4*	Year 4 Charges per Billing Freq	% incr Yr 4-5*	Year 5 Charges per Billing Freq	Billing Freq
40757482	West Proflex	\$5,300.00	1.00%	\$5353.00	1.00%	\$5406.53	1.00%	\$5460.60	1.00%	\$5515.21	Monthly

### Charges During Minimum Term

Pricing is displayed only for the years included in the Minimum Term. Years without pricing in above grid are not included in the Minimum Term. Refer to your Order Form for the Post Minimum Term pricing. Refer to Order Form for Billing Frequency Type.



**Agenda Sheet for City Council:**

**Committee:** PIES **Date:** 04/15/2024

**Committee Agenda type:** Consent

**Council Meeting Date:** 06/10/2024

<b>Date Rec'd</b>	5/29/2024
<b>Clerk's File #</b>	OPR 2024-0462
<b>Cross Ref #</b>	
<b>Project #</b>	2021046, 047, 048

<b>Submitting Dept</b>	ENGINEERING SERVICES	<b>Bid #</b>	
<b>Contact Name/Phone</b>	DAN BULLER 625-6391	<b>Requisition #</b>	
<b>Contact E-Mail</b>	DBULLER@SPOKANECITY.ORG		
<b>Agenda Item Type</b>	Engineer Construction Contract		
<b>Council Sponsor(s)</b>	BWILKERSON JBINGLE KKLITZKE		
<b>Agenda Item Name</b>	0370 – LOW BID AWARD – TRAFFIC CALMING PROJECTS CYCLE 11 (2021046)		

**Agenda Wording**

Low Bid of (to be determined at bid opening) (City, ST) for Traffic Calming Cycle 11 - \$\_\_. An administrative reserve of \$\_\_, which is 10% of the contract, will be set aside. (Various Neighborhood Councils)

**Summary (Background)**

On \_\_\_\_, bids were opened for the above project. The low bid was from (to be determined at bid opening) in the amount of \$\_\_, which is \$\_\_ or \_\_% (above/below) the Engineer's Estimate of \_\_. \_\_ other bids were received as follows: (to be determined). All information will be provided prior to the council vote date.

Lease? NO Grant related? NO Public Works? YES

**Fiscal Impact**

Approved in Current Year Budget? YES

Total Cost	\$
Current Year Cost	\$
Subsequent Year(s) Cost	\$

**Narrative**

Amount	Budget Account
Select \$	#
Select \$	#
Select \$	#
Select \$	#
\$	#
\$	#



**Continuation of Wording, Summary, Approvals, and Distribution**

**Agenda Wording**

**Summary (Background)**

**Approvals**

<b><u>Dept Head</u></b>	BULLER, DAN
<b><u>Division Director</u></b>	FEIST, MARLENE
<b><u>Accounting Manager</u></b>	ORLOB, KIMBERLY
<b><u>Legal</u></b>	HARRINGTON,
<b><u>For the Mayor</u></b>	PICCOLO, MIKE

**Additional Approvals**

**Distribution List**

	ddaniels@spokanecity.org
eraea@spokanecity.org	publicworksaccounting@spokanecity.org
	jgraff@spokanecity.org
pyoung@spokanecity.org	

## Committee Agenda Sheet

### Public Infrastructure, Environment & Sustainability Committee

<b>Committee Date</b>	4-15-24
<b>Submitting Department</b>	Engineering Services
<b>Contact Name</b>	Dan Buller
<b>Contact Email &amp; Phone</b>	<a href="mailto:dbuller@spokanecity.org">dbuller@spokanecity.org</a> , 625-6391
<b>Council Sponsor(s)</b>	Wilkerson, Bingle, Klitzke
<b>Select Agenda Item Type</b>	<input checked="" type="checkbox"/> Consent <input type="checkbox"/> Discussion    Time Requested:
<b>Agenda Item Name</b>	Traffic Calming Cycle 11
<b>Proposed Council Action</b>	<input checked="" type="checkbox"/> Approval to proceed to Legislative Agenda <input type="checkbox"/> Information Only
<b>Summary (Background)</b>  *use the Fiscal Impact box below for relevant financial information	<ul style="list-style-type: none"> <li>This is the annual neighborhood traffic calming project funded by red light camera funds.</li> <li>Project components can be seen in the attached exhibits and are spread throughout the city.</li> <li>This project will advertise in May with work occurring this summer and fall.</li> </ul>
<p><b>Fiscal Impact</b></p> <p><b>Approved in current year budget?</b>    <input checked="" type="checkbox"/> Yes    <input type="checkbox"/> No    <input type="checkbox"/> N/A</p> <p>Total Cost: <u>\$1.5M</u>              Current year cost: \$1.5M              Subsequent year(s) cost:</p> <p><b>Narrative:</b> Please provide financial due diligence review, as applicable, such as number and type of positions, grant match requirements, summary type details (personnel, maintenance and supplies, capital, revenue), impact on rates, fees, or future shared revenue</p> <p><b>Funding Source</b>    <input checked="" type="checkbox"/> One-time    <input type="checkbox"/> Recurring    <input type="checkbox"/> N/A          Specify funding source: Select Funding Source*          Is this funding source sustainable for future years, months, etc? <a href="#">Click or tap here to enter text.</a></p> <p><b>Expense Occurrence</b>    <input checked="" type="checkbox"/> One-time    <input type="checkbox"/> Recurring    <input type="checkbox"/> N/A</p> <p>Other budget impacts: (revenue generating, match requirements, etc.)</p>	
<p><b>Operations Impacts</b> (If N/A, please give a brief description as to why)</p> <ul style="list-style-type: none"> <li>What impacts would the proposal have on historically excluded communities? Public works services and projects are designed to serve all citizens and businesses. We strive to offer a consistent level of service to all, to distribute public investment throughout the community and to respond to gaps in services identified in various City plans.</li> <li>How will data be collected, analyzed, and reported concerning the effect of the program/policy by racial, ethnic, gender identity, national origin, income level, disability, sexual orientation, or other existing disparities? N/A</li> <li>How will data be collected regarding the effectiveness of this program, policy, or product to ensure it is the right solution?</li> </ul>	

Public Works follows the City's established procurement and public works bidding regulations and policies to bring items forward, and then uses contract management best practices to ensure desired outcomes and regulatory compliance.

- Describe how this proposal aligns with current City Policies, including the Comprehensive Plan, Sustainability Action Plan, Capital Improvement Program, Neighborhood Master Plans, Council Resolutions, and others?

This work is consistent with annual budget strategies to limit costs and approved projects in the 6-year CIP.

#### **Council Subcommittee Review**

- Please provide a summary of council subcommittee review. If not reviewed by a council subcommittee, please explain why not.





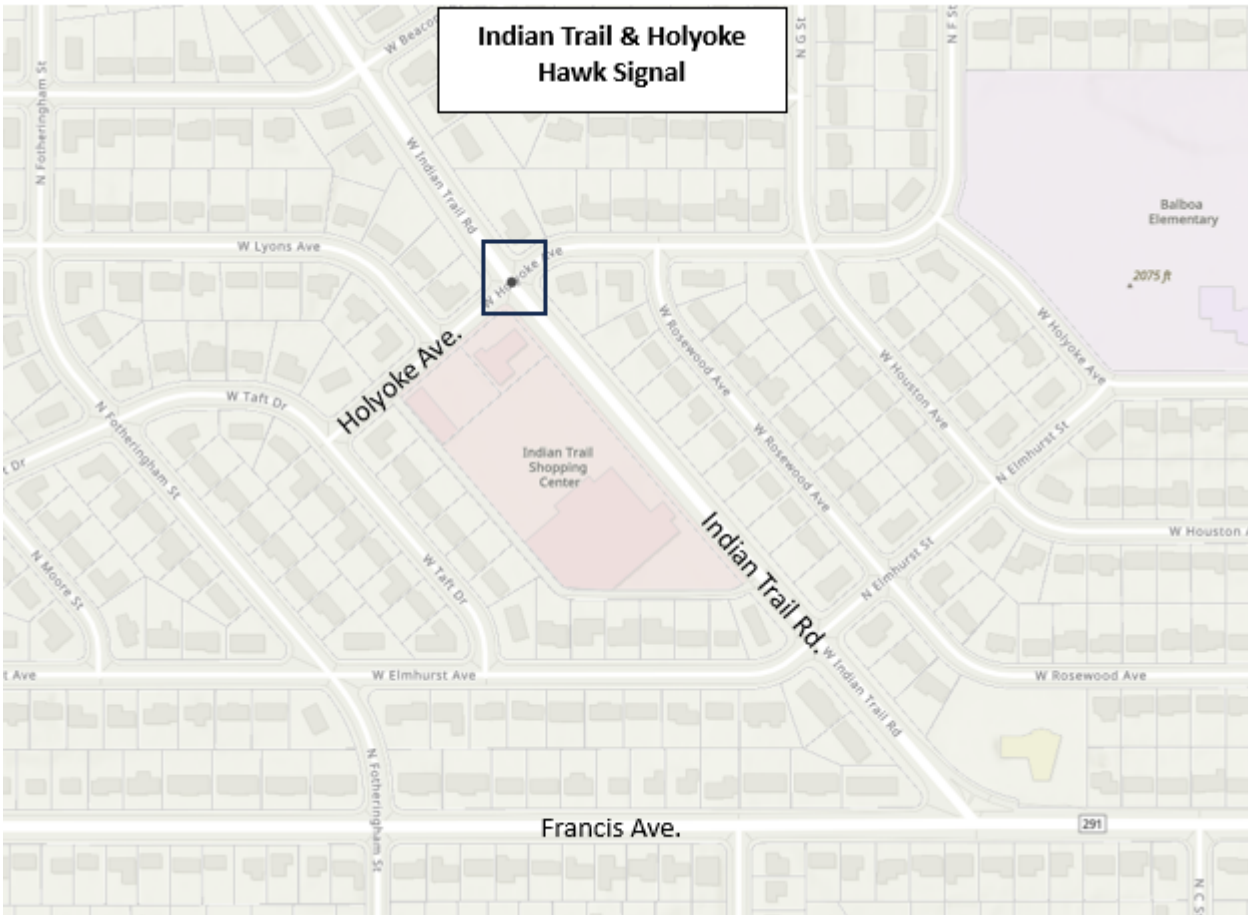
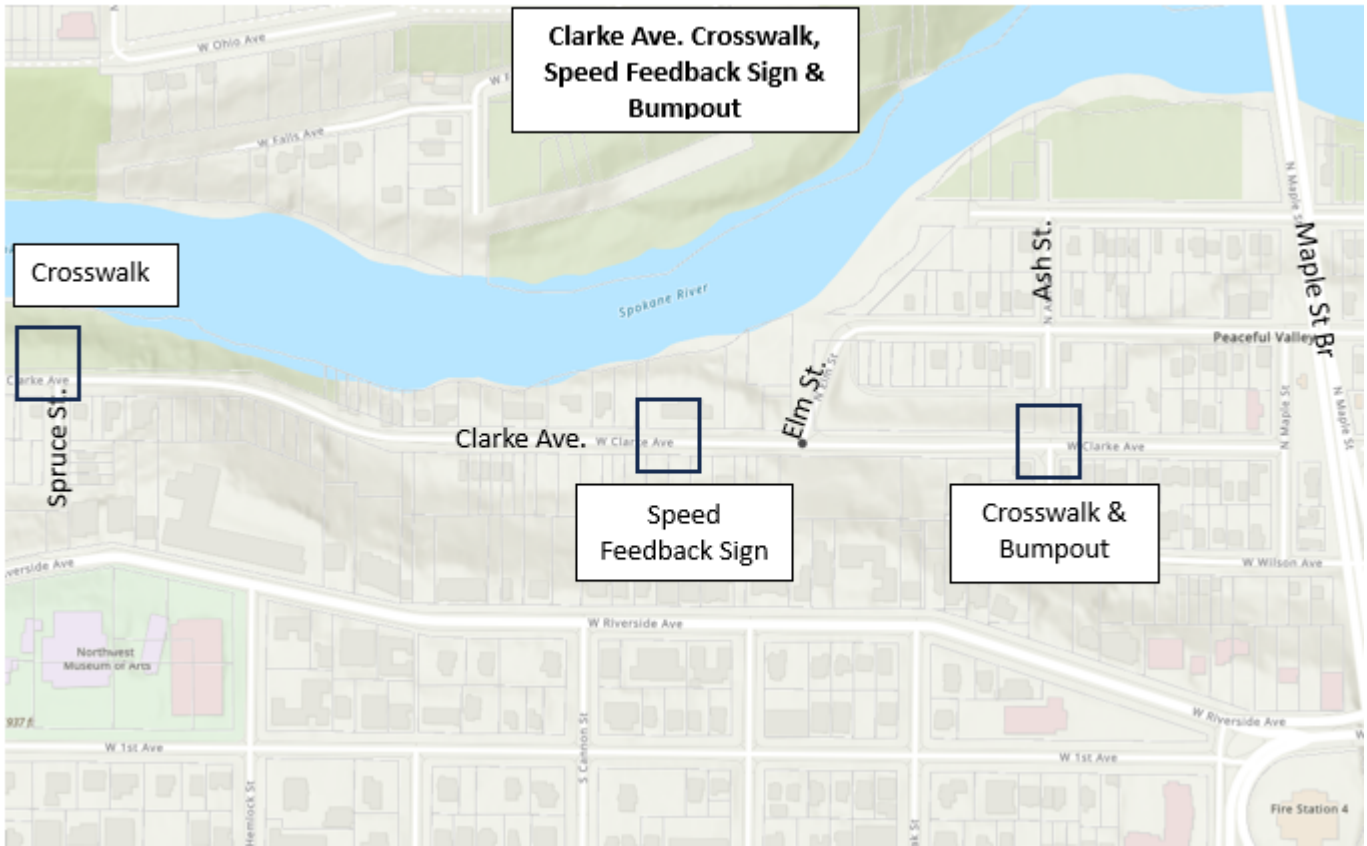

**Liberty & Lidgerwood  
Curb Bumpouts**

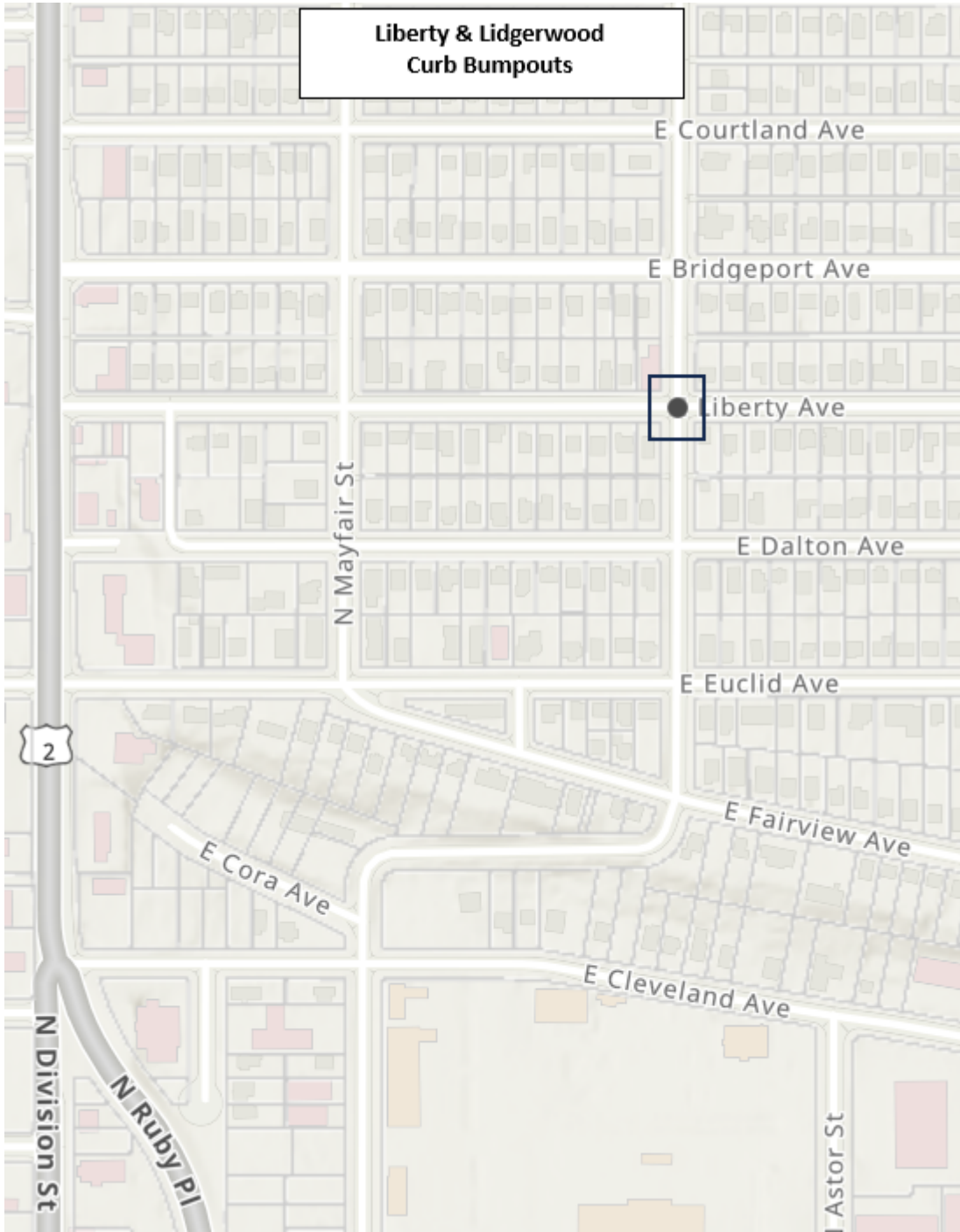

**Standard St. Islands**

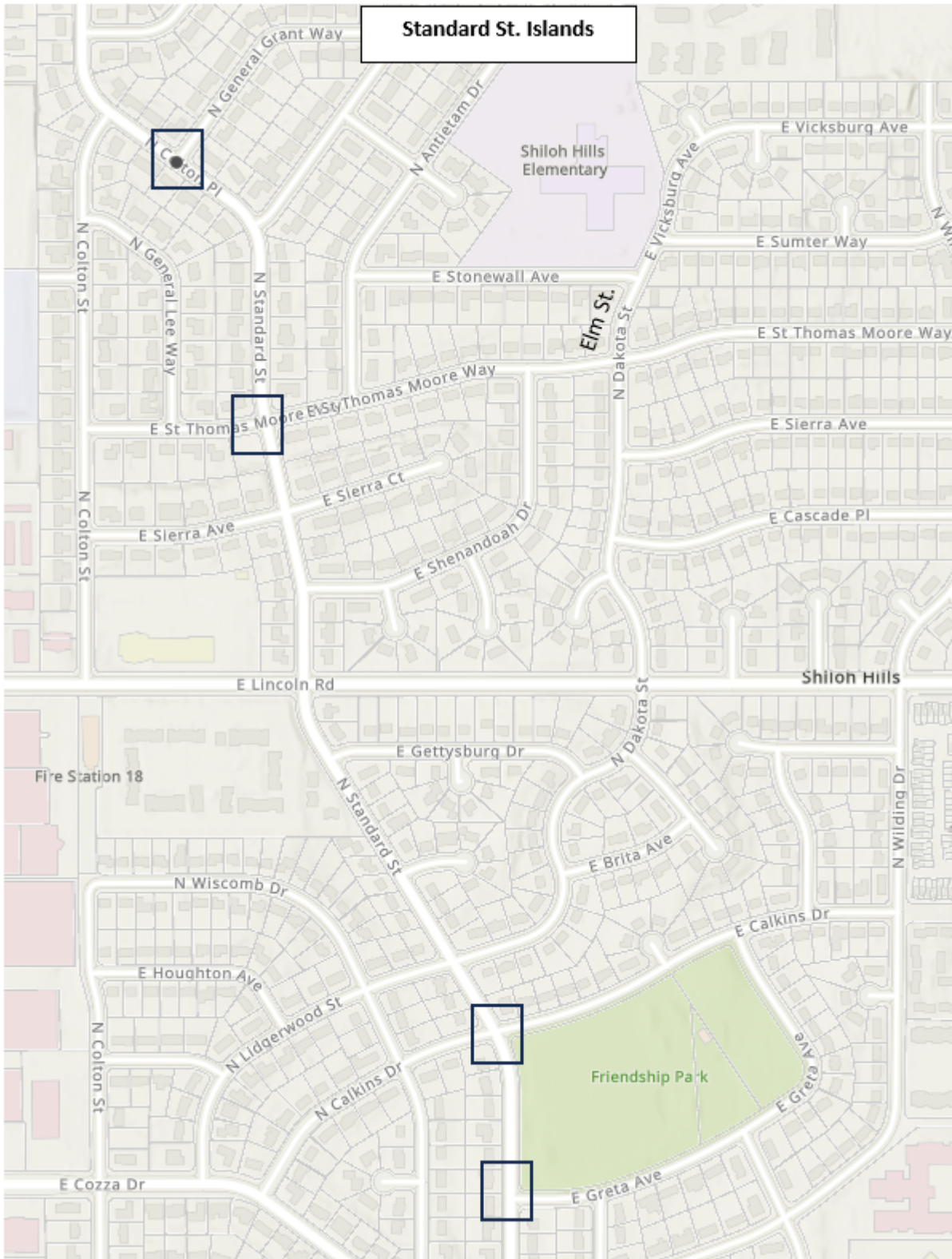



**Agenda Sheet for City Council:**

**Committee:** PIES **Date:** 05/20/2024

**Committee Agenda type:** Consent

**Date Rec'd** 5/20/2024

**Clerk's File #** OPR 2024-0463

**Cross Ref #**

**Project #** RFQ 24-002

**Council Meeting Date:** 06/10/2024

<b>Submitting Dept</b>	FACILITIES MANAGEMENT	<b>Bid #</b>	
------------------------	-----------------------	--------------	--

<b>Contact Name/Phone</b>	DAVE STEELE 625-6064	<b>Requisition #</b>	
---------------------------	----------------------	----------------------	--

<b>Contact E-Mail</b>	DSTEELE@SPOKANECITY.ORG		
-----------------------	-------------------------	--	--

<b>Agenda Item Type</b>	Contract Item		
-------------------------	---------------	--	--

<b>Council Sponsor(s)</b>	BWILKERSON JBINGLE KKLITZKE		
---------------------------	-----------------------------	--	--

<b>Agenda Item Name</b>	5900 FACILITIES CITY HALL FACILITY ASSESSMENT		
-------------------------	---	--	--

**Agenda Wording**

The Facilities Department has completed the scoping, procurement, and contract development for completion of a detailed facility inventory and assessment of City Hall.

**Summary (Background)**

This work will complete an inventory and assessment of the building envelope, critical HVAC systems and other mechanical equipment, as well as the structural elements of the building such as foundation, walls, and roof. this date will allow for the rapid development of updated itemized capital planning documents for this critical facility, providing the information needed to develop detailed plans for completing capital equipment or system replacements, to complete required repair.

Lease? NO Grant related? NO Public Works? NO

**Fiscal Impact**

Approved in Current Year Budget?

Total Cost	\$ 60,385.00
------------	--------------

Current Year Cost	\$ 60,385.00
-------------------	--------------

Subsequent Year(s) Cost	\$
-------------------------	----

**Narrative**

This will provide the Facilities Department required information to develop detailed plans for completing capital equipment or system replacements, to complete required repair work and develop preventative maintenance schedules, etc.

**Amount**

**Budget Account**

Expense	\$ 60,385.00	# 5900-71300-18300-54201-81062
---------	--------------	--------------------------------

Select	\$	#
--------	----	---

Select	\$	#
--------	----	---

Select	\$	#
--------	----	---

	\$	#
--	----	---

	\$	#
--	----	---



## Committee Agenda Sheet

### Public Infrastructure, Environment & Sustainability Committee

<b>Submitting Department</b>	Facilities Department
<b>Contact Name</b>	Dave Steele
<b>Contact Email &amp; Phone</b>	509-625-6064
<b>Council Sponsor(s)</b>	CP Wilkerson, CM Bingle and CM Klitzke
<b>Select Agenda Item Type</b>	<input checked="" type="checkbox"/> Consent <input type="checkbox"/> Discussion    Time Requested:
<b>Agenda Item Name</b>	City Hall Facility Assessment
<b>Summary (Background)</b>  *Use the Fiscal Impact box below for relevant financial information	The Facilities Department has completed the scoping, procurement, and contract development for completion of a detailed facility inventory & assessment for City Hall. This work will complete an inventory and assessment of the building envelope, critical HVAC systems and other mechanical equipment, as well as the structural elements of the building such as foundation, walls, and roof. This data will allow for the rapid development of updated itemized capital planning documents for this critical facility, providing the Facilities Department the information needed to develop detailed plans for completing capital equipment or system replacements, to complete required repair work, and develop preventative maintenance schedules, etc.
<b>Proposed Council Action</b>	Contract approval
<b>Fiscal Impact</b>	
Total Expense: \$60,385.00	
Approved in current year budget? <input checked="" type="checkbox"/> Yes <input type="checkbox"/> No <input checked="" type="checkbox"/> N/A	
Funding Source <input checked="" type="checkbox"/> One-time <input type="checkbox"/> Recurring <input type="checkbox"/> N/A	
Specify funding source:	
Expense Occurrence <input checked="" type="checkbox"/> One-time <input type="checkbox"/> Recurring <input type="checkbox"/> N/A	
Other budget impacts: (revenue generating, match requirements, etc.) Reduction of long term replacement costs by completing proper ongoing maintenance.	
<b>Operations Impacts (If N/A, please give a brief description as to why)</b>	
What impacts would the proposal have on historically excluded communities?	
NA	
How will data be collected, analyzed, and reported concerning the effect of the program/policy by racial, ethnic, gender identity, national origin, income level, disability, sexual orientation, or other existing disparities?	

NA

How will data be collected regarding the effectiveness of this program, policy, or product to ensure it is the right solution?

NA

Describe how this proposal aligns with current City Policies, including the Comprehensive Plan, Sustainability Action Plan, Capital Improvement Program, Neighborhood Master Plans, Council Resolutions, and others?

Continuing to invest in City Hall with this assessment, as the seat of our local government, provides for long term capital planning and ongoing investments in an existing facility. This directly supports the Comprehensive Plan along with a multitude of City resolutions, policies, plans.





**City of Spokane**  
**CONSULTANT AGREEMENT**  
**Title: FACILITY CONDITION**  
**ASSESSMENT OF CITY HALL**

This Consultant Agreement is made and entered into by and between the **CITY OF SPOKANE** as (“City”), a Washington municipal corporation, and **BUREAU VERITAS TECHNICAL ASSESSMENTS LLC**, whose address is 6041 University Boulevard, Suite 200, Elliott City, Maryland 21043, as (“Consultant”), individually hereafter referenced as a “party”, and together as the “parties”.

WHEREAS, the purpose of this Agreement is for Consultant to provide a Facility Assessment of City Hall; and

WHEREAS, the Consultant was selected from an Informal Request for Proposals.

NOW, THEREFORE, in consideration of the terms, conditions, covenants and performance of the Scope of Work contained herein, the City and Consultant mutually agree as follows:

**1. TERM OF AGREEMENT.**

The term of this Agreement begins on June 17, 2024, and ends on May 31, 2027, unless amended by written agreement or terminated earlier under the provisions.

**2. TIME OF BEGINNING AND COMPLETION.**

The Consultant shall begin the work outlined in the “Scope of Work” (“Work”) on the beginning date, above. The City will acknowledge in writing when the Work is complete. Time limits established under this Agreement shall not be extended because of delays for which the Consultant is responsible, but may be extended by the City, in writing, for the City’s convenience or conditions beyond the Consultant’s control.

**3. SCOPE OF WORK.**

The General Scope of Work for this Agreement is described in Consultant’s Proposal dated April 23, 2004, which is attached as Exhibit B and made a part of this Agreement. In the event of a conflict or discrepancy in the contract documents, the City Agreement controls.

The Work is subject to City review and approval. The Consultant shall confer with the City periodically, and prepare and present information and materials (e.g. detailed outline of completed Work) requested by the City to determine the adequacy of the Work or Consultant’s progress.



#### 4. COMPENSATION.

Total compensation for Consultant's services under this Agreement shall not exceed **SIXTY-THOUSAND THREE HUNDRED EIGHTY-FIVE AND NO/100 DOLLARS (\$60,385.00)**, plus applicable sales tax, unless modified by a written amendment to this Agreement. This is the maximum amount to be paid under this Agreement for the work described in Section 3 above, and shall not be exceeded without the prior written authorization of the City in the form of an executed amendment to this Agreement.

#### 5. PAYMENT.

The Consultant shall submit its applications for payment to City of Spokane Facilities Management Department, [facilitiesdepartment@spokanecity.org](mailto:facilitiesdepartment@spokanecity.org), Attn: Dave Steele. **Payment will be made via direct deposit/ACH** within thirty (30) days after receipt of the Consultant's application except as provided by state law. If the City objects to all or any portion of the invoice, it shall notify the Consultant and pay that portion of the invoice not in dispute. In that event, the parties shall immediately make every effort to settle the disputed amount.

#### 6. REIMBURSABLES

The reimbursables under this Agreement are to be included, and considered part of the maximum amount not to exceed (above), and require the Consultant's submittal of appropriate documentation and actual itemized receipts, the following limitations apply.

- A. City will reimburse the Consultant at actual cost for expenditures that are pre-approved by the City in writing and are necessary and directly applicable to the work required by this Contract provided that similar direct project costs related to the contracts of other clients are consistently accounted for in a like manner. Such direct project costs may not be charged as part of overhead expenses or include a markup. Other direct charges may include, but are not limited to the following types of items: travel, printing, cell phone, supplies, materials, computer charges, and fees of subconsultants.
- B. The billing for third party direct expenses specifically identifiable with this project shall be an itemized listing of the charges supported by copies of the original bills, invoices, expense accounts, subconsultant paid invoices, and other supporting documents used by the Consultant to generate invoice(s) to the City. The original supporting documents shall be available to the City for inspection upon request. All charges must be necessary for the services provided under this Contract.
- C. The City will reimburse the actual cost for travel expenses incurred as evidenced by copies of receipts (excluding meals) supporting such travel expenses, and in accordance with the City of Spokane Travel Policy, details of which can be provided upon request.
- D. **Airfare:** Airfare will be reimbursed at the actual cost of the airline ticket. The City will reimburse for Economy or Coach Fare only. Receipts detailing each airfare are required.
- E. **Meals:** Meals will be reimbursed at the Federal Per Diem daily meal rate for the city in which the work is performed. *Receipts are not required as documentation.* The invoice shall state "the meals are being billed at the Federal Per Diem daily meal rate", and shall detail how many of each meal is being billed (e.g. the number of breakfasts, lunches, and dinners). The City will not reimburse for alcohol at any time.
- F. **Lodging:** Lodging will be reimbursed at actual cost incurred up to a maximum of the published General Services Administration (GSA) Index for the city in which the work is performed (*the current maximum allowed reimbursement amount can be provided upon request*). Receipts detailing each day / night lodging are

required. The City will not reimburse for ancillary expenses charged to the room (e.g. movies, laundry, mini bar, refreshment center, fitness center, sundry items, etc.)

- G. **Vehicle mileage:** Vehicle mileage will be reimbursed at the Federal Internal Revenue Service Standard Business Mileage Rate in affect at the time the mileage expense is incurred. Please note: payment for mileage for long distances traveled will not be more than an equivalent trip round-trip airfare of a common carrier for a coach or economy class ticket.
- H. **Rental Car:** Rental car expenses will be reimbursed at the actual cost of the rental. Rental car receipts are required for all rental car expenses. The City will reimburse for a standard car of a mid-size class or less. The City will not reimburse for ancillary expenses charged to the car rental (e.g. GPS unit).
- I. **Miscellaneous Travel** (e.g. parking, rental car gas, taxi, shuttle, toll fees, ferry fees, etc.): Miscellaneous travel expenses will be reimbursed at the actual cost incurred. Receipts are required for each expense of \$10.00 or more.
- J. **Miscellaneous other business expenses** (e.g. printing, photo development, binding): Other miscellaneous business expenses will be reimbursed at the actual cost incurred and may not include a markup. Receipts are required for all miscellaneous expenses that are billed.
- K. **Subconsultant:** Subconsultant expenses will be reimbursed at the actual cost incurred and a four percent (4%) markup. Copies of all Subconsultant invoices that are rebilled to the City are required.

## 7. TAXES, FEES AND LICENSES.

- A. Consultant shall pay and maintain in current status, all necessary licenses, fees, assessments, permit charges, etc. necessary to conduct the work included under this Agreement. It is the Consultant's sole responsibility to monitor and determine changes or the enactment of any subsequent requirements for said fees, assessments, or changes and to immediately comply.
- B. Where required by state statute, ordinance or regulation, Consultant shall pay and maintain in current status all taxes necessary for performance. Consultant shall not charge the City for federal excise taxes. The City will furnish Consultant an exemption certificate where appropriate.
- C. The Director of Finance and Administrative Services may withhold payment pending satisfactory resolution of unpaid taxes and fees due the City.
- D. The cost of any permits, licenses, fees, etc. arising as a result of the projects included in this Agreement shall be included in the project budgets.

## 8. CITY OF SPOKANE BUSINESS LICENSE.

Section 8.01.070 of the Spokane Municipal Code states that no person may engage in business with the City without first having obtained a valid annual business registration. The Consultant shall be responsible for contacting the State of Washington Business License Services at <http://bls.dor.wa.gov> or 1-800-451-7985 to obtain a business registration. If the Consultant does not believe it is required to obtain a business registration, it may contact the City's Taxes and Licenses Division at (509) 625-6070 to request an exemption status determination.

## 9. SOCIAL EQUITY REQUIREMENTS.

No individual shall be excluded from participation in, denied the benefit of, subjected to discrimination under, or denied employment in the administration of or in connection with this Agreement because of age, sex, race, color, religion, creed, marital status, familial status, sexual orientation including gender expression or gender identity, national origin, honorably discharged

veteran or military status, the presence of any sensory, mental or physical disability, or use of a service animal by a person with disabilities. Consultant agrees to comply with, and to require that all subcontractors comply with, Section 504 of the Rehabilitation Act of 1973 and the Americans with Disabilities Act, as applicable to the Consultant. Consultant shall seek inclusion of woman and minority business for subcontracting. A woman or minority business is one that self-identifies to be at least 51% owned by a woman and/or minority. Such firms do not have to be certified by the State of Washington.

#### **10. INDEMNIFICATION.**

The Consultant shall defend, indemnify, and hold the City and its officers and employees harmless from all claims, demands, or suits at law or equity asserted by third parties for bodily injury (including death) and/or property damage which arise from the Consultant's negligence or willful misconduct under this Agreement, including attorneys' fees and litigation costs; provided that nothing herein shall require a Consultant to indemnify the City against and hold harmless the City from claims, demands or suits based solely upon the negligence of the City, its agents, officers, and employees. If a claim or suit is caused by or results from the concurrent negligence of the Consultant's agents or employees and the City, its agents, officers and employees, this indemnity provision shall be valid and enforceable to the extent of the negligence of the Consultant, its agents or employees. The Consultant specifically assumes liability and agrees to defend, indemnify, and hold the City harmless for actions brought by the Consultant's own employees against the City and, solely for the purpose of this indemnification and defense, the Consultant specifically waives any immunity under the Washington State industrial insurance law, or Title 51 RCW. The Consultant recognizes that this waiver was specifically entered into pursuant to the provisions of RCW 4.24.115 and was the subject of mutual negotiation. The indemnity and agreement to defend and hold the City harmless provided for in this section shall survive any termination or expiration of this agreement.

#### **11. INSURANCE.**

During the period of the Agreement, the Consultant shall maintain in force at its own expense, each insurance noted below with companies or through sources approved by the State Insurance Commissioner pursuant to RCW Title 48;

- A. Worker's Compensation Insurance in compliance with RCW 51.12.020, which requires subject employers to provide workers' compensation coverage for all their subject workers and Employer's Liability Insurance in the amount of \$1,000,000;
- B. General Liability Insurance on an occurrence basis, with a combined single limit of not less than \$1,000,000 each occurrence for bodily injury and property damage. It shall include contractual liability coverage for the indemnity provided under this agreement. It shall provide that the City, its officers and employees are additional insureds but only with respect to the Consultant's services to be provided under this Agreement;
  - i. Acceptable **supplementary Umbrella insurance** coverage combined with Consultant's General Liability insurance policy must be a minimum of \$1,000,000, in order to meet the insurance coverage limits required in this Agreement; and
- C. Automobile Liability Insurance with a combined single limit, or the equivalent of not less than \$1,000,000 each accident for bodily injury and property damage, including coverage for owned, hired and non-owned vehicles.

- D. Professional Liability Insurance with a combined single limit of not less than \$1,000,000 each claim, incident or occurrence. This is to cover damages caused by the error, omission, or negligent acts related to the professional services to be provided under this Agreement. The coverage must remain in effect for at least two (2) years after the Agreement is completed.

There shall be no cancellation, material change, reduction of limits or intent not to renew the insurance coverage(s) without sixty (60) days written notice from the Consultant or its insurer(s) to the City. As evidence of the insurance coverage(s) required by this Agreement, the Consultant shall furnish acceptable Certificates Of Insurance (COI) to the City at the time it returns this signed Agreement. The certificate shall specify the City of Spokane as "Additional Insured" specifically for Consultant's services under this Agreement, as well as all of the parties who are additional insureds, and include applicable policy endorsements, the sixty (60) day cancellation clause, and the deduction or retention level. The Consultant shall be financially responsible for all pertinent deductibles, self-insured retentions, and/or self-insurance.

## **12. DEBARMENT AND SUSPENSION.**

The Consultant has provided its certification that it is in compliance with and shall not contract with individuals or organizations which are debarred, suspended, or otherwise excluded from or ineligible from participation in Federal Assistance Programs under Executive Order 12549 and "Debarment and Suspension", codified at 29 CFR part 98.

## **13. AUDIT.**

Upon request, the Consultant shall permit the City and any other governmental agency ("Agency") involved in the funding of the Work to inspect and audit all pertinent books and records. This includes work of the Consultant, any subconsultant, or any other person or entity that performed connected or related Work. Such books and records shall be made available upon reasonable notice of a request by the City, including up to three (3) years after final payment or release of withheld amounts. Such inspection and audit shall occur in Spokane County, Washington, or other reasonable locations mutually agreed to by the parties. The Consultant shall permit the City to copy such books and records at its own expense. The Consultant shall ensure that inspection, audit and copying rights of the City is a condition of any subcontract, agreement or other arrangement under which any other persons or entity may perform Work under this Agreement.

## **14. INDEPENDENT CONSULTANT.**

- A. The Consultant is an independent Consultant. This Agreement does not intend the Consultant to act as a City employee. The City has neither direct nor immediate control over the Consultant nor the right to control the manner or means by which the Consultant works. Neither the Consultant nor any Consultant employee shall be an employee of the City. This Agreement prohibits the Consultant to act as an agent or legal representative of the City. The Consultant is not granted express or implied rights or authority to assume or create any obligation or responsibility for or in the name of the City, or to bind the City. The City is not liable for or obligated to pay sick leave, vacation pay, or any other benefit of employment, nor to pay social security or other tax that may arise from employment. The Consultant shall pay all income and other taxes as due. The Consultant may perform work for other parties; the City is not the exclusive user of the services that the Consultant provides.
- B. If the City needs the Consultant to Work on City premises and/or with City equipment, the City may provide the necessary premises and equipment. Such

premises and equipment are exclusively for the Work and not to be used for any other purpose.

- C. If the Consultant works on the City premises using City equipment, the Consultant remains an independent Consultant and not a City employee. The Consultant will notify the City Project Manager if s/he or any other Workers are within ninety (90) days of a consecutive 36-month placement on City property. If the City determines using City premises or equipment is unnecessary to complete the Work, the Consultant will be required to work from its own office space or in the field. The City may negotiate a reduction in Consultant fees or charge a rental fee based on the actual costs to the City, for City premises or equipment.

#### **15. KEY PERSONS.**

The Consultant shall not transfer or reassign any individual designated in this Agreement as essential to the Work, nor shall those key persons, or employees of Consultant identified as to be involved in the Project Work be replaced, removed or withdrawn from the Work without the express written consent of the City, which shall not be unreasonably withheld. If any such individual leaves the Consultant's employment, the Consultant shall present to the City one or more individuals with greater or equal qualifications as a replacement, subject to the City's approval, which shall not be unreasonably withheld. The City's approval does not release the Consultant from its obligations under this Agreement.

#### **16. ASSIGNMENT AND SUBCONTRACTING.**

The Consultant shall not assign or subcontract its obligations under this Agreement without the City's written consent, which may be granted or withheld in the City's sole discretion. Any subcontract made by the Consultant shall incorporate by reference this Agreement, except as otherwise provided. The Consultant shall require that all subconsultants comply with the obligations and requirements of the subcontract. The City's consent to any assignment or subcontract does not release the consultant from liability or any obligation within this Agreement, whether before or after City consent, assignment or subcontract.

#### **17. CITY ETHICS CODE.**

- A. Consultant shall promptly notify the City in writing of any person expected to be a Consultant Worker (including any Consultant employee, subconsultant, principal, or owner) and was a former City officer or employee within the past twelve (12) months.
- B. Consultant shall ensure compliance with the City Ethics Code by any Consultant Worker when the Work or matter related to the Work is performed by a Consultant Worker who has been a City officer or employee within the past two (2) years.
- C. Consultant shall not directly or indirectly offer anything of value (such as retainers, loans, entertainment, favors, gifts, tickets, trips, favors, bonuses, donations, special discounts, work or meals) to any City employee, volunteer or official that is intended, or may appear to a reasonable person to be intended, to obtain or give special consideration to the Consultant. Promotional items worth less than \$25 may be distributed by the Consultant to a City employee if the Consultant uses the items as routine and standard promotional materials. Any violation of this provision may cause termination of this Agreement. Nothing in this Agreement prohibits donations to campaigns for election to City office, so long as the donation is disclosed as required by the election campaign disclosure laws of the City and of the State.

**18. NO CONFLICT OF INTEREST.**

Consultant confirms that the Consultant or workers have no business interest or a close family relationship with any City officer or employee who was or will be involved in the consultant selection, negotiation, drafting, signing, administration or evaluation of the Consultant's work. As used in this Section, the term Consultant includes any worker of the Consultant who was, is, or will be, involved in negotiation, drafting, signing, administration or performance of the Agreement. The term "close family relationship" refers to: spouse or domestic partner, any dependent parent, parent-in-law, child, son-in-law, daughter-in-law; or any parent, parent in-law, sibling, uncle, aunt, cousin, niece or nephew residing in the household of a City officer or employee described above.

**19. ERRORS AND OMISSIONS, CORRECTIONS.**

Consultant is responsible for professional quality, technical accuracy, and the coordination of all designs, drawings, specifications, and other services furnished by or on the behalf of the Consultant under this Agreement in the delivery of a final work product. The standard of care applicable to Consultant's services will be the degree of skill and diligence normally employed by professional engineers or Consultants performing the same or similar services at the time said services are performed. The Final Work Product is defined as a stamped, signed work product. Consultant, without additional compensation, shall correct or revise errors or mistakes in designs, drawings, specifications, and/or other consultant services immediately upon notification by the City. The obligation provided for in this Section regarding acts or omissions resulting from this Agreement survives Agreement termination or expiration.

**20. INTELLECTUAL PROPERTY RIGHTS.**

- A. Copyrights. The Consultant shall retain the copyright (including the right of reuse) to all materials and documents prepared by the Consultant for the Work, whether or not the Work is completed. The Consultant grants to the City a non-exclusive, irrevocable, unlimited, royalty-free license to use copy and distribute every document and all the materials prepared by the Consultant for the City under this Agreement. If requested by the City, a copy of all drawings, prints, plans, field notes, reports, documents, files, input materials, output materials, the media upon which they are located (including cards, tapes, discs, and other storage facilities), software program or packages (including source code or codes, object codes, upgrades, revisions, modifications, and any related materials) and/or any other related documents or materials developed solely for and paid for by the City to perform the Work, shall be promptly delivered to the City.
- B. Patents: The Consultant assigns to the City all rights in any invention, improvement, or discovery, with all related information, including but not limited to designs, specifications, data, patent rights and findings developed with the performance of the Agreement or any subcontract. Notwithstanding the above, the Consultant does not convey to the City, nor does the City obtain, any right to any document or material utilized by the Consultant created or produced separate from the Agreement or was pre-existing material (not already owned by the City), provided that the Consultant has identified in writing such material as pre-existing prior to commencement of the Work. If pre-existing materials are incorporated in the work, the Consultant grants the City an irrevocable, non-exclusive right and/or license to use, execute, reproduce, display and transfer the pre-existing material, but only as an inseparable part of the work.
- C. The City may make and retain copies of such documents for its information and reference with their use on the project. The Consultant does not represent or warrant that such documents are suitable for reuse by the City or others, on

extensions of the project or on any other project, and the City releases the Consultant from liability for any unauthorized reuse of such documents.

**21. CONFIDENTIALITY.**

Notwithstanding anything to the contrary, City will maintain the confidentiality of Consultant's materials and information only to the extent that is legally allowed in the State of Washington. City is bound by the State Public Records Act, RCW Ch. 42.56. That law presumptively makes all records in the possession of the City public records which are freely available upon request by anyone. In the event that City gets a valid public records request for Consultant's materials or information and the City determines there are exemptions only the Consultant can assert, City will endeavor to give Consultant notice. Consultant will be required to go to Court to get an injunction preventing the release of the requested records. In the event that Consultant does not get a timely injunction preventing the release of the records, the City will comply with the Public Records Act and release the records.

**22. DISPUTES.**

Any dispute or misunderstanding that may arise under this Agreement, concerning the Consultant's performance, shall first be through negotiations, if possible, between the Consultant's Project Manager and the City's Project Manager. It shall be referred to the Director and the Consultant's senior executive(s). If such officials do not agree upon a decision within a reasonable period of time, either party may decline or discontinue such discussions and may then pursue the legal means to resolve such disputes, including but not limited to mediation, arbitration and/or alternative dispute resolution processes. Nothing in this dispute process shall mitigate the rights of the City to terminate the Agreement. Notwithstanding all of the above, if the City believes in good faith that some portion of the Work has not been completed satisfactorily, the City may require the Consultant to correct such work prior to the City payment. The City will provide to the Consultant an explanation of the concern and the remedy that the City expects. The City may withhold from any payment otherwise due, an amount that the City in good faith finds to be under dispute, or if the Consultant provides no sufficient remedy, the City may retain the amount equal to the cost to the City for otherwise correcting or remedying the work not properly completed. Waiver of any of these rights is not deemed a future waiver of any such right or remedy available at law, contract or equity.

**23. TERMINATION.**

- A. For Cause: The City or Consultant may terminate the Agreement if the other party is in material breach of this Agreement, and such breach has not been corrected to the other party's reasonable satisfaction in a timely manner. Notice of termination under this Section shall be given by the party terminating this Agreement to the other, not fewer than thirty (30) business days prior to the effective date of termination.
- B. For Reasons Beyond Control of Parties: Either party may terminate this Agreement without recourse by the other where performance is rendered impossible or impracticable for reasons beyond such party's reasonable control, such as, but not limited to, an act of nature, war or warlike operation, civil commotion, riot, labor dispute including strike, walkout or lockout, except labor disputes involving the Consultant's own employees, sabotage, or superior governmental regulation or control. Notice of termination under this Section shall be given by the party terminating this Agreement to the other, not fewer than thirty (30) business days prior to the effective date of termination.
- C. For Convenience: Either party may terminate this Agreement without cause, upon thirty (30) days written notice to the other party.

- D. Actions upon Termination: if termination occurs not the fault of the Consultant, the Consultant shall be paid for the services properly performed prior to the actual termination date, with any reimbursable expenses then due, but such compensation shall not exceed the maximum compensation to be paid under the Agreement. The Consultant agrees this payment shall fully and adequately compensate the Consultant and all subconsultants for all profits, costs, expenses, losses, liabilities, damages, taxes and charges of any kind (whether foreseen or unforeseen) attributable to the termination of this Agreement.
- E. Upon termination, the Consultant shall provide the City with the most current design documents, contract documents, writings and other products the Consultant has produced to termination, along with copies of all project-related correspondence and similar items. The City shall have the same rights to use these materials as if termination had not occurred; provided however, that the City shall indemnify and hold the Consultant harmless from any claims, losses, or damages to the extent caused by modifications made by the City to the Consultant's work product.

#### **24. EXPANSION FOR NEW WORK.**

This Agreement scope may be expanded for new work. Any expansion for New Work (work not specified within the original Scope of Work Section of this Agreement, and/or not specified in the original RFP as intended work for the Agreement) must comply with all the following limitations and requirements: (a) the New Work is not reasonable to solicit separately; (b) the New Work is for reasonable purpose; (c) the New Work was not reasonably known either the City or Consultant at time of contract or else was mentioned as a possibility in the solicitation (such as future phases of work, or a change in law); (d) the New Work is not significant enough to be reasonably regarded as an independent body of work; (e) the New Work would not have attracted a different field of competition; and (f) the change does not vary the essential identified or main purposes of the Agreement. The City may make exceptions for immaterial changes, emergency or sole source conditions, or other situations required in City opinion. Certain changes are not New Work subject to these limitations, such as additional phases of Work anticipated at the time of solicitation, time extensions, Work Orders issued on an On-Call contract, and similar. New Work must be mutually agreed and issued by the City through written Addenda. New Work performed before an authorizing Amendment may not be eligible for payment.

#### **25. MISCELLANEOUS PROVISIONS.**

- A. Amendments: No modification of this Agreement shall be effective unless in writing and signed by an authorized representative of each of the parties hereto.
- B. Binding Agreement: This Agreement shall not be binding until signed by both parties. The provisions, covenants and conditions in this Agreement shall bind the parties, their legal heirs, representatives, successors and assigns.
- C. Americans with Disabilities Act (ADA): Specific attention by the designer is required in association with the Americans with Disabilities Act (ADA) 42 U.S.C. 12101-12213 and 47 U.S.C. 225 and 611, its requirements, regulations, standards and guidelines, which were updated in 2010 and are effective and mandatory for all State and local government facilities and places of public accommodation for construction projects including alteration of existing facilities, as of March 15, 2012. The City advises that the requirements for accessibility under the ADA, may contain provisions that differ substantively from accessibility provisions in applicable State and City codes, and if the provisions of the ADA impose a greater or equal protection for the rights of individuals with disabilities or individuals associated with them than the adopted local codes, the ADA prevail unless



approval for an exception is obtained by a formal documented process. Where local codes provide exceptions from accessibility requirements that differ from the ADA Standards; such exceptions may not be permitted for publicly owned facilities subject to Title II requirements unless the same exception exists in the Title II regulations. It is the responsibility of the designer to determine the code provisions.

- D. The Consultant, at no expense to the City, shall comply with all laws of the United States and Washington, the Charter and ordinances of the City of Spokane; and rules, regulations, orders and directives of their administrative agencies and officers. Without limiting the generality of this paragraph, the Consultant shall comply with the requirements of this Section.
- E. This Agreement shall be construed and interpreted under the laws of Washington. The venue of any action brought shall be in the Superior Court of Spokane County.
- F. Remedies Cumulative: Rights under this Agreement are cumulative and nonexclusive of any other remedy of law or in equity.
- G. Captions: The titles of sections or subsections are for convenience only and do not define or limit the contents.
- H. Severability: If any term or provision is determined by a court of competent jurisdiction to be invalid or unenforceable, the remainder of this Agreement shall not be affected, and each term and provision shall be valid and enforceable to the fullest extent permitted by law.
- I. Waiver: No covenant, term or condition or the breach shall be deemed waived, except by written consent of the party against whom the waiver is claimed, and any waiver of the breach of any covenant, term or condition shall not be deemed a waiver of any preceding or succeeding breach of the same or any other covenant, term or condition. Neither the acceptance by the City of any performance by the Consultant after the time the same shall have become due nor payment to the Consultant for any portion of the Work shall constitute a waiver by the City of the breach or default of any covenant, term or condition unless otherwise expressly agreed to by the City in writing.
- J. Additional Provisions: This Agreement may be modified by additional terms and conditions ("Special Conditions") which shall be attached to this Agreement as an Exhibit. The parties agree that the Special Conditions shall supplement the terms and conditions of the Agreement, and in the event of ambiguity or conflict with the terms and conditions of the Agreement, these Special Conditions shall govern.
- K. Entire Agreement: This document along with any exhibits and all attachments, and subsequently issued addenda, comprises the entire agreement between the City and the Consultant. If conflict occurs between contract documents and applicable laws, codes, ordinances or regulations, the most stringent or legally binding requirement shall govern and be considered a part of this contract to afford the City the maximum benefits.
- L. Negotiated Agreement: The parties acknowledge this is a negotiated agreement, that they have had this Agreement reviewed by their respective legal counsel, and that the terms and conditions of this Agreement are not to be construed against any party on the basis of such party's draftsmanship.
- M. No personal liability: No officer, agent or authorized employee of the City shall be personally responsible for any liability arising under this Agreement, whether expressed or implied, nor for any statement or representation made or in any connection with this Agreement.

IN WITNESS WHEREOF, in consideration of the terms, conditions and covenants contained, or attached and incorporated and made a part, the parties have executed this Agreement by having legally-binding representatives affix their signatures below.

**BUREAU VERITAS TECHNICAL ASSESSMENTS LLC**

**CITY OF SPOKANE**

By \_\_\_\_\_  
Signature                      Date

By \_\_\_\_\_  
Signature                      Date

\_\_\_\_\_  
Type or Print Name

\_\_\_\_\_  
Type or Print Name

\_\_\_\_\_  
Title

\_\_\_\_\_  
Title

Attest:

Approved as to form:

\_\_\_\_\_  
City Clerk

\_\_\_\_\_  
Assistant City Attorney

**Attachments:** Exhibit A – Certificate Regarding Debarment  
Exhibit B – Consultant’s April 23, 2024 Proposal

24-085

**EXHIBIT A**

**CERTIFICATION REGARDING DEBARMENT, SUSPENSION,  
INELIGIBILITY AND VOLUNTARY EXCLUSION**

1. The undersigned (i.e., signatory for the Subrecipient / Contractor / Consultant) certifies, to the best of its knowledge and belief, that it and its principals:
  - a. Are not presently debarred, suspended, proposed for debarment, declared ineligible, or voluntarily excluded from covered transactions by any federal department or agency;
  - b. Have not within a three-year period preceding this contract been convicted or had a civil judgment rendered against them for commission of fraud or a criminal offense in connection with obtaining, attempting to obtain, or performing a public (federal, state, or local) transaction or contract under a public transaction; violation of federal or state antitrust statutes or commission of embezzlement, theft, forgery, bribery, falsification or destruction of records, making false statements, tax evasion, receiving stolen property, making false claims, or obstruction of justice;
  - c. Are not presently indicted or otherwise criminally or civilly charged by a government entity (federal, state, or local) with commission of any of the offenses enumerated in paragraph (1)(b) of this certification; and,
  - d. Have not within a three-year period preceding this contract had one or more public transactions (federal, state, or local) terminated for cause or default.
  
2. The undersigned agrees by signing this contract that it shall not knowingly enter into any lower tier covered transaction with a person who is debarred, suspended, declared ineligible, or voluntarily excluded from participation in this covered transaction.
  
3. The undersigned further agrees by signing this contract that it will include the following clause, without modification, in all lower tier covered transactions and in all solicitations for lower tier covered transactions:

Certification Regarding Debarment, Suspension, Ineligibility and Voluntary Exclusion – Lower Tier Covered Transactions

1. The lower tier contractor certified, by signing this contract that neither it nor its principals is presently debarred, suspended, proposed for debarment, declared ineligible, or voluntarily excluded from participation in this transaction by any federal department or agency.
  
2. Where the lower tier contractor is unable to certify to any of the statements in this contract, such contractor shall attach an explanation to this contract.
  
4. I understand that a false statement of this certification may be grounds for termination of the contract.

<hr/> Name of Subrecipient / Contractor / Consultant (Type or Print)	<hr/> Program Title (Type or Print)
<hr/> Name of Certifying Official (Type or Print)	<hr/> Signature
<hr/> Title of Certifying Official (Type or Print)	<hr/> Date (Type or Print)

**EXHIBIT B**



**BUREAU  
VERITAS**

April 23, 2024

Via Email: DSteele@spokanecity.org

Mr. David Steele, Project Manager  
City of Spokane  
808 W. Spokane Falls Blvd  
Spokane, WA 99201

**RE: City Hall, City of Spokane, RFP 24-005**  
Proposal No: 164793.23

Dear Mr. Steele:

We are pleased to provide the City of Spokane (hereinafter referred to as “Client”) with the following proposal. If accepted, Bureau Veritas Technical Assessments LLC (hereinafter referred to as “BVTA”) will perform the services listed below (collectively, the “Services”) meeting the specifications hereafter described.

**Property(ies)**

City Hall  
808 West Spokane Falls Blvd  
Spokane, WA  
161,000 SF  
8 stories (including basement)

**Proposed Service(s) & Fee(s)**

Service(s)	Lump Sum Fee(s)
Facility Condition Assessment Asset & Equipment Inventory (for CMMS) Barcode Labels & Affixation	\$8,750.00
Data Migration to CMMS**	\$250.00
ADA/Accessibility Survey	\$6,460.00
Floorplans (includes roof & electrical plans)	\$44,925.00
<b>TOTAL</b>	<b>\$60,385.00</b>

\*\*Does not include any fees charged by CMMS provider

All fees referred to in this document are expressed in US Dollars. Pricing is not inclusive of taxes. If applicable, taxes shall be included at the time of invoicing, payable by the client and remitted by BVTA to the taxing municipality. The proposed fees are limited to the specific Services described in this Proposal, performed according to the requirements of the corresponding ASTM standard practices, or Client-specified Protocols.

**Deliverable(s)**

The quoted price includes the delivery of:

# of	Report Type	Method of Delivery
3	Draft & Final	Email Full Report (PDF)

Unless otherwise specified, BVTA will submit all reports in Final format. Timing for completion of any requested post-delivery

modifications to the report will be determined at the time of the request.

If different deliverables are required, please indicate the quantity, type and method of delivery on the Project Authorization page of this proposal.

**Timing**

BVTA’s report(s) will be delivered within 35-40 full business/working days after receipt and approval of the signed proposal document.

After engagement, a call will be placed to the designated onsite Point of Contact (POC) provided by the Client in order to schedule the site visit(s), where applicable. The Client acknowledges that the Point of Contact provided shall be deemed an agent of the Client for the purposes of providing access and conveying information pertaining to the Site.

**Projects Placed on Hold or Canceled**

Should the Client place the awarded project on hold or cancel the engagement after contract execution, the Client agrees to pay project-specific costs incurred by BVTA, such as administrative processing, regulatory database searches and non-recoverable travel fees, as well as a percentage of the project fee, depending upon the time the project is placed on hold or cancelled. Please note that BVTA invoices canceled jobs at the time of cancellation. Jobs on hold will be automatically invoiced 30 days from the date of the hold request. Requests to cancel or place projects on or off hold must be received by BVTA in writing (email acceptable) from the Client. Invoices billed as a result of projects being placed on hold or canceled are fully collectible.

Project Change in Status Stage	Billing Stage
Canceled between >24 hours after award and 4 Business Days prior to onsite	\$150 per report plus project expenses
Project canceled within 3 Business Days (72 hours) prior to onsite visit	\$250 per report plus project expenses
Project placed on hold or canceled <24 hours before, during, or following completion of the onsite visit, but prior to report writing/review	\$1,250 lost man-day rate plus project expenses
Project placed on hold or canceled during or after report writing/review	100% of project fee

**Payment & Details**

An invoice for payment will be submitted with the initial report deliverable(s) and will be payable within 30 days or upon the closing of the transaction, whichever comes first. Upon receipt of the initial report deliverable(s); the invoice is fully collectible. Please forward payments to: Accounting Department, Bureau Veritas Technical Assessments LLC, PO Box 74007289, Chicago, IL 60674-7289 or contact your BVTA administrator to pay via credit card or to receive wiring instructions. BVTA recommends payment by credit card for amounts less than \$1000. **Please ensure that Proposal #164793.23 or invoice number is clearly identified on all payments and correspondence for proper credit.**

Billing Milestone	Percentage Invoiced
Completion of onsite assessments	50% of per site fee
Delivery of Draft Reports	95% of per site fee
Delivery of Final* Reports	5% of per site fee

\*If comments on the Draft reports are not received within 60 calendar days, BVTA will invoice for Final Reports.

**Documents to be Furnished by Client**

In order to facilitate a cursory review of pre-existing documents for each Project, BVTA asks to be furnished with electronic or printed copies of available site information. Such documents may include:

**FCA Services:**

- Inspection Reports (sewer, boiler, chiller, etc)
- Prior Engineering Reports (CNA, PNA, PCA, etc.)
- Prior Master Plans / Facility Master Plans
- Capital Expenditure Schedules (prior or planned)
- Rehabilitation budget & scope (draft or final)
- Accessibility Transition Plans/Self Evaluations
- Building Systems Maintenance Records
- Owner Elected Repair list (if available)
- Original Building Plans (can be viewed on-site)
- Fire Protection/Life Safety Plans
- Site Plan/Floor Plans

**Note:** Documents to be reviewed should be provided to BVTA within five (5) business days and not less than one (1) day prior to the onsite. In the event that documents can only be made available at the Site, BVTA will perform a cursory review during the site visit as time permits. If documents are received after the site visit date, or if the volume of documentation is determined by BVTA to be excessive, then the Project may be subject to additional review fees at the rate of \$215.00 per hour. Any additional review fees will be mutually agreed upon by BVTA and the Client at the time of review request and will be authorized using a Change Order.

**Terms & Conditions**

BVTA will perform its Services subject to the attached "Terms & Conditions", which are incorporated by reference and made a part of this Proposal. Please indicate your acceptance of this Proposal by signing the attached "Project Authorization" page where indicated and return it to BVTA.

Please feel free to contact me at 800.733.0660 x.7297936 or leilani.york@bureauveritas.com should you have any questions. BVTA welcomes the opportunity to be of service.

Sincerely,

**Bureau Veritas Technical Assessments LLC**



Leilani R. York  
Associate Vice President of Sales

**Attachments:**

*Description of Services*  
*Terms & Conditions*  
*Project Authorization*



## Description of Services

### Facility Condition Assessment

---

#### Project Understanding

Bureau Veritas (BV) understands that the Facility Condition Assessment (FCA) for the City of Spokane will:

- Include a comprehensive assessment of all sites, buildings, building systems, layout and infrastructure.
- The FCA will follow the ASTM E2018-15 Standard Guide for Property Condition Assessments as applicable.
- Determine the present condition and estimated life expectancy of various building systems and components.
- Identify and document present condition of all physical assets including grounds, facilities, and infrastructure.
- Recommend corrections for all deficiencies and provide cost estimates for corrections.
- Prioritize and categorize deficient conditions, associated corrective actions, and information concerning building systems and deficiency categories.
- Establish anticipated renewal and replacement costs for the various systems and components.
- Result in strategic plan for capital repairs, lifecycle component replacement, and building modernization.
- Calculate the Current Replacement Value (CRV) and Facility Condition Index (FCI) for each facility.

**Property Information** – The County has requested the abovementioned services for:

- One (1) public building facility totaling ~161,000 square feet.

We understand that a key factor to performing Facility Condition Assessments is the evaluation of physical needs and accurate forecasting for capital repair and replacement budgets. Pre-emptive measures to manage maintenance budgets and programs are essential in ensuring the elimination of potential issues, which can range from deferred maintenance, or premature replacement of building systems that can prove costly.

BV's Project Approach has been developed to address your specific requirements. BV has demonstrated experience in the assessment of various types of facilities representative to your portfolio and understands the special implementation, sensitivities, management, and communication associated with each.

#### Data Gathering and Interview

Our project plan details three distinct phases of the project. During each phase, we will require coordination and support from facility management.

**Data Gathering Phase** – During this phase, we will need the support of staff who can provide us access to drawings and records. The following is a typical list of exhibits requested.

- Inspection Reports (sewer, boiler, chiller, etc.)
- Building Systems Maintenance Records
- Owner Elected Repair list (if available)
- Original Building Plans (can be viewed on-site)
- Capital Expenditure Schedules (prior or planned)
- Fire Protection / Life Safety Plans
- Rehabilitation Budget and Scope (draft or final)
- Certificates of Occupancy / Facility License
- Prior Assessments
- Site Plan / Floor Plans
- Accessibility Transition Plans / Studies
- CMMS / IWMS Data Set
- Gravel Pit review – Prior Geological reports



In addition to the drawings and records, we will supply a pre-survey questionnaire for each facility or site. Our expectation is that someone with knowledge of maintenance and operations of the facility will complete this survey and be prepared to discuss it with us while on-site

**Site Phase** – During the site phase, we will need support in the form of escorts while in the facilities to help us access mechanical areas, to discuss with us any known issues in the facility, and to answer other technical questions.

**Report Review Stage** – During the reports review stage – we will provide a complete draft deliverable for each building/site.

## Client Coordination

**Project Directory:** BV will become familiar with Client’s existing property list and contact directory for each location. We will contact or interview the facilities contacts as part of our process to determine current use requirements and priority of properties based on agency goals.

**Facility Access:** Working with Client we will develop procedures to gain access to each facility. Our visits will be coordinated and pre-approved by Client prior to the visit. We will work with Client to establish a protocol that will ensure that our activities will have minimal disruption to the operation of each facility and will maintain a safe work environment.

## Team Composition

The project will be managed by a Program Manager who will be your single point of contact. Reporting to the Program Manager will be several Project Managers who are architectural and engineering subject matter experts (SME) in the evaluation of building systems and generating the reports. We evaluate the building portfolio to determine which team members will be assigned to particular sites. Larger or more complex sites may have both an architect and an engineering SME. Smaller or simpler buildings will have a single SME field assessor that understands all building systems.

### Assessment Team

BV has several support staff that assist with the report and data development which include:

- Environmental Professional to assist with the fuel distribution facilities
- Asset Management Team Leader who manages and configures the cost estimating database
- Technical Report Reviewers who review reports for accuracy and consistency
- Quality Assurance Manager for oversight of quality controls
- IT Manager who assists with data development and export

The Assessment Team will observe, measure, record, and describe the deficiencies observed through the process; interview staff; and formulate recommendations to remedy the deficiencies. They will coordinate the logistics and document collection for each assessment, as well as develop the assessment reports.

## Technical Approach

Prior to assessments beginning, BV will conduct a **Kickoff** session to review requirements and to consolidate exhibits such as drawings and prior completed reports.

During the term of the project, BV will conduct regular **Progress Meetings** to maintain open communication with the entire project team and Client. In these meetings, BV will lead with an agenda that includes a focus on work plan, schedule, and project needs. This will permit the opportunity to proactively address challenges encountered, so that course adjustments may be made. Each meeting will conclude with task assignments, schedules, and goals to be met. BV will provide Client with a written status report that tracks and monitors the progress of the assessments against the schedule submitted.

BV has allocated the following meetings: Kick Off Meeting and a Final Findings Presentation meeting. Any additional in-person meetings will be on a time and expense basis.

## Field Assessments

The assessment team will conduct a walk-through survey of the facility and site to observe systems and components, identify physical deficiencies, and formulate recommendations to remedy the physical deficiencies.

- As a part of the walk-through survey, the assessment team will survey 100% of each facility. BV will survey the exterior and grounds, including the building exterior, roofs, sidewalk/pavement, and other areas as applicable.
- The assessment team will interview the building maintenance staff about the subject property's historical repairs and replacements and their costs, level of preventive maintenance exercised, pending repairs and improvements, and frequency of repairs and replacements.
- The assessment team will develop opinions based on their site assessment, interviews with Client's building maintenance staff, and interviews with relevant maintenance contractors, municipal authorities, and experience gained on similar properties previously evaluated. The assessment team may also question others who are knowledgeable of the subject property's physical condition and operation or knowledgeable of similar systems to gain comparative information to use in evaluation of the subject property.
- The assessment team will review documents and information provided by Client's maintenance staff that could also aid the knowledge of the subject property's physical improvements, extent and type of use, and/or assist in identifying material discrepancies between reported information and observed conditions.

The facility condition assessment will focus on the following facility and site systems and components:

### Site + Infrastructure

- Topography: Observe the general topography and note any unusual or problematic features or conditions observed or reported.
- Paving, Curbing, and Parking: Identify the material types of paving and curbing systems at the subject property.
- Flatwork: Identify the material flatwork at the subject property (sidewalks, plazas, patios, etc.).
- Landscaping and Appurtenances: Identify the material landscaping features, material types of landscaping (fences, retaining walls, etc.), and site appurtenances (irrigation systems, fountains, lighting, signage, ponds, etc.).
- Utilities: Identify the type of the material utilities provided to the property (water, electricity, natural gas, etc.). We will assess condition, physical deficiencies, life cycle repair, capacity, and replacement issues.

### Structural Frame + Building Envelope

- Identify the material elements of the structural frame and exterior walls, including the foundation system, floor framing system, roof framing system, facade or curtain-wall system, glazing system, exterior sealant, doors, commercial overhead doors, sliders, windows, and stairways, etc.
- Observe the general conditions and note any physical deficiencies identified or any unusual items or conditions observed. Observations may be subject to grade, and rooftop vantage points.
- Visual inspection of observable areas for cracking and moisture infiltration as well as areas of apparent foundation settlement and displacement.
- In the event more information or exploratory testing is required, in order to provide remedial measures, the report may include recommendation for additional investigative testing (Tier 1 or Tier 2).

### Wall Evaluation

- Photograph elevations and details both from internal and external vantage points, as well as from adjacent structures where possible.
- Observe representative operable and fixed panels on all facades, operating a representative sample of units to assess hardware, and to visually inspect exterior conditions and the condition of waterproofing seals.
- Assess curtain wall condition to determine water infiltration, damage, caulk degradation, metal panel degradation, stone degradation and anchoring, and other related curtain wall issues.

### Curtain Wall – As Required

- Review curtain wall condition and a sampling of fixed panels on facades to assess hardware and visually review exterior conditions and the condition of waterproofing seals, where accessible without the use of lifts, ladders, scaffolding, suspension devices, or the like; this may include observations from internal and external vantage points, as well as from adjacent structures. Observations are limited to grade and may include accessible balconies or rooftop vantage points.
- Review provided drawings and records of repair, replacement, and maintenance of framing and glazing

### Roofing (Non-Invasive Visual)

- Identify the material roof systems including roof type, reported age, slope, drainage, etc. Also identify any unusual roofing conditions or rooftop equipment.
- Observe the general conditions of the roof system such as membranes, attachment methods, flashings, counter flashings, pitch pans, gravel stops, parapets, miscellaneous appurtenances, insulation, etc.
- Observe for evidence of material repairs, significant ponding, or evidence of material roof leaks. Note if a roof warranty is in effect. Note any physical deficiencies identified or any unusual items observed or reported.
- Identify the material rooftop equipment or accessories including antennas, lightning protection, HVAC equipment, solar equipment, etc. Include any material problems reported.
- BV understands that the Client will provide OSHA compliant ladders or scaffolding (depending on roof type) so that the Project Manager may safely access roof areas. If requested, BV can provide a quote for ladder access as needed. Observations will be limited to readily accessible areas.

### Plumbing

- Identify the material plumbing systems at the subject property including domestic water supply, sanitary sewer, or any special or unusual plumbing systems (such as water features, fuel systems, gas systems, etc.).
- Identify the type and condition of restroom fixtures, drinking fountains and/or other miscellaneous plumbing equipment.
- Observe the general conditions and note any physical deficiencies identified or any unusual items or conditions observed. Include any reported material system inadequacies.

### Heating

- Identify the material heat generating systems at the subject property.
- Observe the general conditions, identify the reported age of the equipment, note past material component replacements/ upgrades, note the apparent level of maintenance, and identify if a maintenance contract is in place. If heating equipment is not operational at the time of the walk-through survey, provide an opinion of the condition to the extent reasonably possible.
- Identify and observe any special or unusual heating systems or equipment present (such as fireplaces, solar heat, etc.) and note any reported material problems or inadequacies.

### Air-Conditioning + Ventilation

- Identify the material air-conditioning and ventilation systems at the subject property. Include material equipment such as cooling towers, chillers (include type of refrigerant used), package units, split systems, air handlers, thermal storage equipment, etc.
- Identify the material distribution systems (supply and return, make-up air, exhaust, etc.) at the subject property.
- Observe the general conditions, identify the reported age of the equipment, note past material component upgrades/ replacements, note the apparent level of maintenance, and identify if a maintenance contract is in place (and the name of the contractor). If air-conditioning and ventilation systems are not operational at the time of the walk-through survey, provide an opinion of the condition to the extent reasonably possible.
- Observe the general conditions and note any physical deficiencies identified or any unusual items or conditions observed. Additionally, include any material reported system inadequacies or operating deficiencies.
- Identify and observe any special or unusual air-conditioning and ventilation systems or equipment (cold storage systems, special computer cooling equipment, etc.) and note any material reported problems or system inadequacies.

### Electrical

- Identify the electrical service provided and distribution system at the subject property. Include material switchgear disconnects, circuit breakers, transformers, meters, emergency generators, general lighting systems, and other such equipment or systems.
- Observe general electrical items such as distribution panels, type of wiring, energy management systems, emergency power, lightning protection, etc.
- Observe the general conditions and note any physical deficiencies identified or any unusual items or conditions observed. Also note the presence of any special or unusual electrical equipment, systems, or devices at the subject property, and include reported material problems or system inadequacies.

### Life Safety + Fire Protection

- Identify the material life safety/fire protection systems at the subject property, including sprinklers and stand pipes (wet or dry), fire hydrants, fire alarm systems, water storage, smoke detectors, fire extinguishers, emergency lighting, stairwell pressurization, smoke evacuation, etc.
- Observe the general conditions and note any material physical deficiencies identified or any unusual items or conditions observed or reported including any reported system inadequacies.

### Elevators + Vertical Transportation

- Identify the vertical transportation systems at the subject property. Include the equipment manufacturer, equipment type, location, number, capacity, etc.
- Observe elevator cabs, finishes, call and communication equipment, etc.
- Identify the company that provides elevator/ escalator maintenance at the subject property. Observe the general conditions and note any physical deficiencies identified or any unusual items or conditions observed or reported including any reported material system inadequacies.
- Out of Scope Issues: Performing any calculations, examination of operating system components such as cables, controller, motors, etc. Entering elevator/escalator pits or shafts.

### Security Systems / Telcom / IT

- Identify the low voltage systems the subject property including security, access control, and IT functions (in the support of IP-based security systems).
- Observe general security systems such as motion detectors, card key access, alarms, and CCTVs.
- Observe extent and availability of wireless communications (WiFi, etc.), hardwiring, room connectivity, and public address systems.
- Observe the general conditions and note any physical deficiencies identified or any unusual items or conditions observed.

### Technology Readiness Evaluation - Security / Internet / IT / Power

- Identify the low voltage systems the subject property including security, access control, and IT functions (in the support of IP-based security systems).
- Observe general security systems such as motion detectors, card key access, alarms, and CCTVs.
- Observe extent and availability of wireless communications (WiFi, etc), hardwiring, room connectivity, and public address systems.
- Observe the general conditions, power levels, and note any physical deficiencies identified or any unusual items or conditions observed.

### Interior Elements

- Identify offices, special use areas and building standard finishes, including flooring, ceilings, walls, etc. Furnishings and fixed components will be reviewed and included in the cost estimate tables for replacements. Additionally, BV will identify material building amenities or special features.

- Observe the general conditions and note any physical deficiencies identified or any unusual items or conditions observed or reported.

#### Food Service Spaces and Equipment

- Assess all Food Service equipment and spaces including kitchen, cafeteria, and dining and serving areas. Food service equipment (fixed equipment) will be evaluated for adherence to life/ safety code and ventilation requirements as well for condition and capital replacement.

#### Special Systems and Equipment

- Include all special systems and equipment, such as Emergency Medical Systems (EMC), chillers, radio towers, equipment lifts, chair lifts, chemical storage or treatment areas, storage tanks, dumbwaiters, vaults, public address systems, and telephone systems.

#### Limited Accessibility Compliance

- Provide a general statement of the subject building's likely compliance to the Americans with Disabilities Act to help identify whether Client may be exposed to issues and whether there is the need for further review.

#### Suspected Fungal Growth

- BV will perform a limited assessment of accessible areas for suspected fungal growth.
- If we discover the presence of mold, conditions conducive to mold growth, and/or evidence of moisture, elevated relative humidity, water intrusion, and mildew-like odors – the affected areas will be photographed and recommendations for any additional moisture intrusion studies will be made.

#### Environmental Features

- BV will review environmental features of the property, to include appearance, cleanliness, acoustics, ventilation, and humidity.

#### Lead-based Paint

- A review of existing testing data and other documentation regarding lead-based paint that is available onsite is included in the cost of the Facilities Condition Assessment. BV will evaluate physical condition and will develop cost estimates for remediation of paint necessitated by pending renovations.
- BV has the capability to provide a licensed lead-based paint inspector to conduct testing using an x-ray fluorescence analyzer at the Project as an additional service. The instrument is completely non-destructive and yields instantaneous results.

#### Asbestos

- A review of existing testing data and other documentation regarding asbestos that is available onsite is included in the cost of the Facilities Condition Assessment. BV will evaluate physical condition and will develop cost estimates for remediation of asbestos likely to be disturbed by renovations.
- If asbestos testing is requested, BV will provide a licensed asbestos inspector to collect samples of suspect asbestos-containing materials at the Project as an additional service. Scope of this sampling will be determined after review of existing data, costs will be based on daily rate plus the cost of analysis.

#### Energy Conservation Analysis – unless required by the RFP I suggest removing the first bullet point as we have trouble with that scope unless we are completing a full energy audit.

- As part of the analysis of all evaluated systems mentioned above, BV will consider energy conservation savings when making repair or replace recommendations and include these projects in the project prioritization.
- BV can provide as additional services an Energy Audit (ASHRAE Level I, II, or III) or Benchmarking (EnergyStar) services.

## Ranking and Classification

Based upon our observations, research and judgment, along with consulting commonly accepted empirical Expected Useful Life (EUL) tables; BV will render our opinion as to when a system or component will most probably necessitate replacement.

Accurate historical replacement records provided by the facility manager are typically the best source for this data. Exposure to the weather elements, initial system quality and installation, extent of use, the quality and amount of preventive maintenance exercised are all factors that impact the effective age of a system or component. As a result, a system or component may have an effective age that is greater or less than its actual age. The Remaining Useful Life (RUL) of a component or system equals the EUL less its effective age.

## Condition Ranking of Building Systems / Equipment

BV can rate the condition of each facility building system or component with this or another Client-specified five-point scale:

5	Excellent	No visible defects, new or near new condition, may still be under warranty if applicable
4	Good	Good condition, but no longer new, may be slightly defective or deteriorated, but is overall functional
3	Adequate	Moderately deteriorated or defective, but has not exceeded useful life
2	Marginal	Defective or deteriorated in need of replacement; exceeded useful life
1	Poor	Critically damaged or in need of immediate repair; well past useful life

BV can also include alternative categories to rank and weight priorities as required by the Client, such as functional deficiencies, aesthetics, time-based urgencies, and other mission critical factors.

## Priority Classes

The analysis will include all cost observations be ranked by Priority Classes. **The five classes below are typical but can be altered to meet your specifications and needs:**

**Priority 1: Currently Critical** (Immediate): Requiring immediate action including a cited safety hazard and areas of accelerated deterioration, returning a building component to normal operation.

**Priority 2: Potentially Critical** (Year 1): Requiring action in the next year including components experiencing intermittent operations, potential life safety issues, and rapid deterioration, returning a building component to normal operation.

**Priority 3: Necessary – Not Yet Critical** (Years 2-3): Requiring appropriate attention to preclude predictable deterioration, potential downtime, additional damage, and higher costs to remediation if deferred further.

**Priority 4: Recommended** (Years 4-10, 15, 20): Representing a sensible improvement to the existing conditions (not required for the most basic function of the facility; however, will improve overall usability and/or reduce long-term maintenance costs).

**Priority 5: Does Not Meet Current Code but “Grandfathered”**: No Action required at this time but should substantial work be undertaken correction would be required.

## Uniformat Categories

The deficiencies observed will be classified into categories such as those below using the Uniformat System (Level 4):

- A10 Foundations
- A20 Basement Construction
- B10 Superstructure
- B20 Exterior Enclosure



- B30 Roofing
- C10 Interior Construction
- C20 Stair
- C30 Interior Finishes
- D10 Conveying
- D20 Plumbing
- D30 HVAC
- D40 Fire Protection
- D50 Electrical
- E10 Equipment
- E20 Furnishings
- F10 Special Construction
- F20 Selective Building Demolition

## Cost Estimating

BV's cost estimating database is comprised of RS Means data and further customized with proprietary cost tables developed by BV, based on historical and localized actual costs. BV maintains and updates our Unifomat-based cost estimating system with information received from the field. Through construction monitoring work, we have current cost data from hundreds of in-progress construction and rehabilitation projects. This data allows us to calculate costs based on local conditions to maintain a cost database that is typically more current than RS Means' models.

Each report will include a Capital Needs Analysis including an estimated cost for each system or component repair or replacement anticipated during the evaluation term. The report will provide options for repair of the deficiency, and the capital needs analysis will be presented as an Excel-based cost table that includes a summary of the description of each component, the age and estimated remaining useful life, the anticipated year of repair or replacement, quantity, unit cost and total cost for the repair of each line item.

A consolidated Capital Needs Analysis will be presented that includes all anticipated capital needs for all buildings. The cost estimate for capital deficiencies will be based on the estimate for maintenance and repair, but may at Client's option, also include project management costs, construction fees, and design fees. Project management costs, construction fees, and design fees will be derived using actual costs from previous projects. After determining these costs, we will confirm these costs with your staff.

## Report Deliverables

BV will provide a report including a description of each of the building components and systems as described in the approach sections above. Each report is organized by building system and will include digital photos of major systems and components and of all deficiencies identified. Reports will include current and anticipated repairs and deficiencies, recommended repair and component life-cycle replacements, and applicable options for repair or maintenance of building components.

The Capital Needs analysis will include a cost database sorted by building system and ranked by priority for repair. The format of the database will allow for reporting by building, by system, or by priority for repair, and a year-by-year analysis of capital needs.

### Facility Condition Index

A Facility Condition Index will be calculated for each building. This index will be a function of required repairs compared to building replacement costs. The Facility Condition Index will be generated from the data collection/capital planning database and will be updated as components age or are replaced.

### Deficiency Categories / Plan Types

Each deficiency identified in the Assessment shall be classified in the following manner (or other Client defined categories):

**Category 1- Scheduled Maintenance:** Maintenance that is planned and performed on a routine basis to maintain and preserve the condition.

**Category 2 - Deferred Maintenance:** Maintenance that was not performed when it was scheduled or is past its useful life resulting in immediate repair or replacement.

**Category 3 - Capital Renewal:** Planned replacement of building systems that have reached the end of their useful life.

**Category 4 - Energy and Sustainability:** When the repair or replacement of equipment or systems are recommended to improve energy and sustainability performance.

**Category 5 - Security:** When a system requires replacement due to a security risk or requirement.

#### **Building Condition Report – Standard:**

Each report will be generally organized by building system and will include an analysis of all building systems and components. Each report will include color digital photos of all major systems and components and will include photos of all deficiencies identified. These deficiencies will be summarized in a capital needs analysis table included throughout each report.

#### **Sustainability Efforts – Digital Reports**

BV regularly takes measures to minimize impacts to the environment in the delivery of services. In lieu of printing reports and meeting minutes, BV makes an effort to be stewards of the environment by using digital distribution for materials. When appropriate, we suggest that in-person meetings be done by teleconference or video conference – in order to reduce our carbon footprint.

#### **Assessment Software: AssetCALC™**

BV will utilize AssetCALC™ as its platform for all data collected on this project. AssetCALC™ is a cloud platform developed, licensed, maintained, and supported solely by BV for our clients. **The use of this software is at your option and there are no licensing fees for this software for one (1) year.**

AssetCALC™ is a web-based SQL database platform that enables users to:

- query, edit, and analyze their facility condition data
- plan immediate and short-term repairs
- budget capital expenditures throughout the life-cycle of a building or an entire portfolio

The system unites BV's experienced field data collection methods with advanced planning and reporting tools, construction cost libraries, location mapping (GIS) features, digital photo management, and document storage.

#### **Data Development**

AssetCALC™ includes a configurable facility hierarchy and asset data architecture - this will include all of your assets grouped based on site location, asset group, and function.

Data can be exported to an Excel, XML, or an ODBC database format compatible for upload into your CMMS, EAM, IWMS, or work-order systems.

#### **Features Include:**

Facility Condition Assessment access:

- Component/system descriptions
- Locations
- Conditions and EUL/RUL
- Repair and replace recommendations
- Digital photos

Search and Sorting Functionality

Prioritization of maintenance projects



UniFormat 2010 Cost Database  
Project Budgets and Capital Plans  
Unlimited concurrent user licensing  
Secure IT platform and back-ups  
Client is the owner of data collected and residing in the database  
Online User Training and Documentation

#### Reporting:

AssetCALC™ includes more than a dozen standard options for data summaries and reports:

Facility Condition Index (FCI) Calculation Reporting  
Rank and Prioritize Capital Improvement Projects  
Deferred Maintenance Backlog  
Facility Queries (by building, priority, system, or dollar deficiency amount)  
Capital Budget Planning  
Year-by-Year Capital Needs Analysis  
5, 10, or 20-Year Replacement Reserve Reports  
Custom 3<sup>rd</sup> party form automation available

## Equipment and Asset Inventory

During the assessment, each field team will be responsible for collection and storing the inventory and condition assessment data in an electronic format that is readily transferable to a standardized CMMS/IWMS system.

BV will collect information on the major pieces of facility equipment. Specifically, the data collection will focus on the following components:

- HVAC (level of detail for which Preventive Maintenance would be performed)
  - Heating System
    - Identify boilers, furnaces, unit heaters and major labeled equipment
  - Ventilation System
    - Identify the major labeled equipment; exhaust hoods, fans
  - Air Conditioning System
    - Identify the material air-conditioning components, including cooling towers, compressors, chillers, package units, roof top units, split systems and major labeled equipment. Excluded are window units, terminal units, VAV boxes, and thermostatic controls
- Electrical
  - Major panels only-for identification to track maintenance
  - Transformers
  - Switchgear
- Equipment
  - Building Automation System
- Plumbing
  - Pumps external to HVAC systems
  - Domestic Hot Water heaters over 80 gallons
  - Other major labeled equipment
- Commercial Kitchen- major equipment (above approximately \$2000 value)
  - Walk-in freezer and refrigerator equipment
  - Ovens, stoves, broilers, grills
  - Ice makers and ice bins
  - Reach-in refrigerators and freezers

- Dishwashers
- Fryers
- Vertical Transportation
- Life Safety/Security
  - High Level (system level) only-for identification to track maintenance
    - Alarm Panels
    - Emergency generators
    - Exhaust hood fire suppression

Where appropriate, the following data will be collected for each component:

- Location data by building, floor, room
- Model
- Serial Number
- Manufacturer
- Manufactured Date
- Capacities
- Date placed in service (provided by Client)
- Inventory tag number (barcoded tag directly attached to the component, or to an attached tag)
- Voltage durable barcode or QR code tag to be attached to each piece of equipment.

## Barcoding / QR Coding

For the above referenced equipment, BV will apply a durable barcode / QR code with a unique number for use as an identifier in the CMMS system. We will use a vinyl tag for indoor applications, and a durable foil tag for outdoor use. Barcode / QR code numbers will be recorded in the database and all future work orders etc., and can be tied back in to a single piece of equipment or system.

## Integration with CMMS/IWMS

BV will be delivering to Client a live asset management plan that can be maintained and kept up-to-date by staff. BV will provide training to staff on maintaining the on-going monitoring program to track facilities, work performed, re-prioritization of maintenance projects, and how to update this information in the database.

The data from the FCA can be exported for data migration to most CMMS/IWMS systems. BV can export the data from our data collection tool to a compatible format (Excel Spreadsheet, Access Database, or SQL format) to be used by the Client's IT department for future integration. Once your CMMS provides us with their field maps – we can match their data fields and provide a data file for manual upload by your CMMS into their system. BV has created several custom APIs to transfer our data directly into some third party systems.

## ADA Title II Accessibility

An assessor will visit the property to observe the exterior areas, interior common areas, and employee only areas to assess the existing property improvements' compliance with the Americans with Disabilities Act and its implementing regulations for Title II entities (28 C.F.R Part 35), the 2010 ADA Standards for Accessible Design, and applicable state and local accessibility codes. BV will then produce a report which identifies the facility's compliance with accessibility requirements and identifies specific barriers, with resolutions for barrier removal, and corresponding preliminary order of magnitude cost estimates.

The assessor will conduct a review of the facility's exterior areas, interior common areas, and employee only areas to observe and identify representative barriers to accessibility and formulate recommendations to remedy the physical barriers. When applicable, as part of the review the assessor will meet with a property representative with specific knowledge of the facility to gain an understanding of overall features, public use patterns, and relevant historical data. All landlord controlled features of the property which will be subject to observation, will include, but not be limited to, parking lots, sidewalks, ramps, curb

ramps, stairs, and restrooms. All exterior elements and elements within the interior areas, which are subject to accessibility regulation, will be observed.

The ADA encompasses employee only areas in addition to public spaces. Under Title I of the ADA, employee work areas, as well as employee only corridors, restrooms, break rooms, and kitchens/kitchenettes are covered under the ADA.

### Observation Process

The assessor will first review documents and information provided by the municipal representative that could supplement the consultant's knowledge of the subject property's physical improvements, extent and type of use, and/or assist in identifying barriers to accessibility.

During the site walk through, the assessor will follow a Survey Form that meets or exceeds the current ASTM format. The assessor will utilize a digital level, measuring tape, door pressure gauge, and GPS-enabled digital camera. The field observer will identify and prioritize any existing improvements not in accordance with the applicable ADA requirements in the order of preference, as set out by BV or per the preferences of Client, as indicated. Typical priorities are as follows:

- Physical access to the property
- Access to areas of public accommodation
- Removal of remaining barriers

The assessor will assess exterior common areas and interior areas to identify existing conditions that are not in accordance with the applicable accessibility codes, including the elements specified below (if applicable, where landlord is responsible for observed elements):

- Van and car accessible parking
- Passenger loading zones
- Accessible routes
- Curb ramps
- Ramps
- Protruding objects
- Building unit entrance exteriors
- Building entrance and exits to common areas
- Interior accessible routes
- Exterior and interior stairs which are part of the means of egress
- Elevators and platform lifts (wheelchair lifts)
- Entrances and exits to common areas
- Handrails and grab bars
- Space allowance and reach ranges
- Restrooms
- Kitchenettes
- Break rooms
- Alarms (visual and audible) and warnings
- Signage
- Public telephones

- Switches and outlets

### Accessibility Survey Content

BV will deliver an electronic (PDF) report. The report will utilize survey content which has been entered into an AssetCalc database, including the following information:

- Summary of Findings for all primary regulated elements observed, such as parking, accessible routes, entrances, elevators, and corridors
- Individually recorded barriers
- Applicable ADA regulatory guideline references for each barrier
- Recommendations for viable corrective measures necessary to comply with applicable regulations
- Preliminary order of magnitude cost estimates for each observed barrier

### ADA Survey Limitations

BV's order of magnitude cost estimates for each individual barrier removal are limited planning level cost estimates based on industry standards, and should not be construed as construction estimates. Costs will be estimated using R.S. Means, Marshall & Swift, or similar industry cost indices, and BV's experience with past costs for similar properties, without the benefit of site-specific engineering/design or contractor estimates. An additional estimating effort will be required to define the actual cost of corrective actions to eliminate accessibility barriers. Planning level estimates are not based on, and will not include, detailed specifications or architectural/engineering drawings. If requested, BV can provide a proposal for subsequent Transition Planning and Construction Project Management services.

### Floorplans (including roof and electrical plans)

#### Scope Specifics:

Roof access will need to be provided by the client.

Includes roof plans on main roof 7th floor, mechanical roof 2nd floor, & patio level/roof area 2nd floor.

Includes plans of skywalk.

Includes plans with striping of west parking lot/loading dock area.

#### Roof Plan Includes:

Building Footprint(s)  
Eaves, Valleys, Hips, & Ridges  
Parapet Walls & Bracing  
Chimneys  
Fixed Equipment  
Skylights  
Drains  
Pitch/Slope Information

#### Electrical Plan Includes the following items on wall and floor (ceiling items excluded):

Outlets & Switches  
Data, Phone, Cable Jacks  
Thermostat  
Electrical Panels & Meters  
Light Fixtures  
Speakers  
Security Systems  
Fire Safety Items

#### Inclusions/Exclusions:

Square foot calculations are not provided unless a Lease Plan is included in scope of work.

Photos are taken by the technicians throughout their measuring process. These photos are strictly to help the CAD technicians view architectural conditions. They are for office use only.

All exterior spaces *connected* to the subject building i.e. decks, exterior stairs, loading docks, etc. will be measured unless otherwise instructed. This does not include poured concrete patios.

This estimate does not include unfinished attics or crawlspaces.

If at any time, field staff encounters an unsafe building condition, they have the right to not proceed with measurement. Client will be notified immediately.

#### Deliverables:

Detailed survey of the property, accurate to 0.2%, measuring and locating all walls, doors, windows, stairwells, elevators, plumbing fixtures, built-in cabinetry and ventilation shafts. All measurements recorded with laser measuring equipment using our custom floor plan software or 3D scanners, depending on scope of work and nature of building.

CAD drawing files AutoCAD format (Standard is AutoCAD 2000) together with PDF graphic files. (NOTE: 1 model DWG + 1 standard 2-D As-Built Floor Plans sheet layout per floor).

**SCALE:** Plans will be set to a graphic scale (not architectural) that fits best on an 8.5"x11", 11"x17" or 24"x36" paper size. Specific scales must be requested prior to the appointment. If rescaling is requested after the plans have been produced, a fee will be incurred. If you are working with an architect, we recommend you consult with them regarding specific scale requests prior to the scheduling of the measurement.

All dimensions are rounded to the nearest inch.



## Terms & Conditions

1. Billings, Payment and Credit. The Client shall pay Bureau Veritas Technical Assessments LLC for the Services performed in accordance with the prices set forth in the Proposal. Invoices shall be submitted in accordance with the Proposal. Payment of the Bureau Veritas Technical Assessments LLC invoices shall be the primary, absolute and non-contingent obligation of the Client, and shall not be conditioned upon the closing of a loan transaction or any other event. Upon receipt of the initial report deliverable(s), the invoice is fully collectible. If Bureau Veritas Technical Assessments LLC does not receive payment in full within thirty (30) calendar days of the date of the invoice, the account shall be deemed delinquent. Unpaid delinquent balances shall bear interest from the invoice date at one and one-half percent (1.5%) per month, or at the maximum lawful interest rate (whichever rate is less). If a delinquency occurs, Bureau Veritas Technical Assessments LLC may, at its option (and without relieving the Client from its payment obligation), revoke and disclaim the Client's right to rely on any report delivered pursuant to the Proposal, until payment in full is made.

The Client shall be liable to Bureau Veritas Technical Assessments LLC for all costs and expenses of collection, including reasonable attorney and paralegal fees, and court costs. Time is of the essence with respect to this provision. Bureau Veritas Technical Assessments LLC's non-exercise of any rights or remedies, whether specified herein or as otherwise provided by law, shall not be deemed a waiver of any rights or remedies, nor preclude Bureau Veritas Technical Assessments LLC from the future exercise of such rights or remedies. If a third party is accepting a Proposal as agent for the Client, such third party represents and warrants to Bureau Veritas Technical Assessments LLC that it is duly authorized to bind the Client to the terms of the Proposal and guarantees payment for services.

2. Right of Entry; Force Majeure. The Client shall arrange for the right of entry to the subject property ("Site") by Bureau Veritas Technical Assessments LLC, its agents, employees, consultants, contractors and subcontractors, for the purpose of performing all acts as may be reasonably necessary to perform the Services within the agreed scope of work. Bureau Veritas Technical Assessments LLC may require that an authorized knowledgeable representative of the owner be present at the Site as a condition to the performance of the Services and may require that site personnel operate major building systems and equipment at the time the Services are performed. Bureau Veritas Technical Assessments LLC's ability to comply with the schedule for performance described in the Proposal is contingent upon timely Site access. Bureau Veritas Technical Assessments LLC shall not be responsible for damages or delays in performance caused by force majeure, acts of God, events beyond the control of Bureau Veritas Technical Assessments LLC, or events that could not have been reasonably foreseen and prevented.
3. Documents; Samples. All field notes, calculations, estimates and other documents, data or information prepared by or on behalf of Bureau Veritas Technical Assessments LLC in connection with the performance of its Service (collectively, "Documents"), shall remain the sole property of Bureau Veritas Technical Assessments LLC. All Documents prepared by Bureau Veritas Technical Assessments LLC for the Client with respect to any Site shall be used solely for the intended purposes described in the Proposal, and solely with respect to the subject Site. Unless otherwise agreed, Bureau Veritas Technical Assessments LLC shall retain all Documents for three (3) years following submission of Bureau Veritas Technical Assessments LLC's report to the Client. In its sole discretion and without prior notice to the Client, Bureau Veritas Technical Assessments LLC may dispose of all field samples within thirty (30) calendar days after submission of Bureau Veritas Technical Assessments LLC's report to the Client.
4. Matters Known to Client. The Client, itself or through the site owner, shall provide Bureau Veritas Technical Assessments LLC with any and all information known to the Client, or suspected by the Client, which pertains to: (a) the existence or possible existence at, on, under or in the vicinity of the Site, of any hazardous materials, pollutants, lead-based paint, radon or asbestos; (b) any conditions at, on, under or in the vicinity of the Site, which might represent a potential safety hazard or danger to human health or the environment; (c) any permit, manifest, title record, or other record of compliance or non-compliance with any federal, state or local laws, or court or administrative order or decrees; (d) known or suspected deficiencies or adverse conditions associated with structures or other physical improvements on Site; or (e) modifications or changes from the original plans and specifications of Site improvements which could affect the recommendations or conclusions reached by Bureau Veritas Technical Assessments LLC in the performance of its Services.
5. Preliminary Findings. Preliminary findings (often referred to as verbals) can be provided to the client in order to quickly apprise them of preliminary data obtained as a result of Bureau Veritas Technical Assessments LLC's visual observations at the project site. They are not intended to be exhaustive or conclusive or to substitute for the final written report; as they do not include the information obtained from a number of other equally important and necessary elements of the complete assessment report. Bureau Veritas Technical Assessments LLC recommends against making any decisions based upon such limited, preliminary, verbal results.
6. WARRANTIES AND INDEMNIFICATION. In performing the Services, Bureau Veritas Technical Assessments LLC shall exercise the degree of skill and care ordinarily exercised by consultants in the same community and in the same time frame providing similar services for projects of comparable size, complexity, schedule and other characteristics of the Project (the "Standard of Care"). **EXCEPT AS SET FORTH IN THE IMMEDIATELY PRECEDING SENTENCE, BUREAU VERITAS TECHNICAL ASSESSMENTS LLC MAKES NO WARRANTY, EXPRESS OR IMPLIED, WITH RESPECT TO THE SERVICES OR ANY OF ITS ORAL OR WRITTEN REPORTS. CLIENT ACKNOWLEDGES AND AGREES THAT (I) THE SERVICES MAY REQUIRE JUDGMENTS TO BE MADE BY BUREAU VERITAS TECHNICAL ASSESSMENTS LLC THAT ARE BASED UPON LIMITED DATA RATHER THAN UPON SCIENTIFIC CERTAINTIES; (II) BUREAU VERITAS TECHNICAL ASSESSMENTS LLC'S APPROACH, RECOMMENDATIONS, AND ASSOCIATED COST ESTIMATES, IF ANY, ARE BASED ON INDUSTRY PRACTICES AND AVERAGES; (III) PROFESSIONAL OPINIONS ARE RENDERED WITH RESPECT TO OBSERVATIONS MADE AND DATA OBTAINED AT THE TIME OF ASSESSMENT; AND (IV) ULTIMATE OUTCOMES COULD BE INCONSISTENT WITH THE CONCLUSIONS, RESULTS AND PROJECTIONS OF BUREAU VERITAS TECHNICAL ASSESSMENTS LLC. ALL INFORMATION REGARDING OPERATIONS, PLANS, SPECIFICATIONS, CONDITIONS OR TEST DATA WHICH IS PROVIDED TO BUREAU VERITAS TECHNICAL ASSESSMENTS LLC BY CLIENT, OWNERS OR THIRD PARTIES (INCLUDING WITHOUT LIMITATION, ANY POINT OF CONTACT AT THE SITE), IS DEEMED BY BUREAU VERITAS TECHNICAL ASSESSMENTS LLC TO BE CORRECT AND COMPLETE WITHOUT INDEPENDENT**



VERIFICATION BY BUREAU VERITAS TECHNICAL ASSESSMENTS LLC. BUREAU VERITAS TECHNICAL ASSESSMENTS LLC ASSUMES NO RESPONSIBILITY FOR THE ACCURACY OF SUCH INFORMATION AND SHALL NOT BE LIABLE IF RELIANCE ON SUCH INFORMATION RESULTS IN INCORRECT CONCLUSIONS OR RESULTS. CLIENT SHALL RELEASE BUREAU VERITAS TECHNICAL ASSESSMENTS LLC FROM ANY AND ALL LIABILITIES, LOSSES, COSTS, DAMAGES, CLAIMS, OBLIGATIONS, FEES AND EXPENSES (INCLUDING REASONABLE ATTORNEYS' FEES) (COLLECTIVELY, "LOSSES"), IF RELYING ON SUCH INFORMATION RESULTS IN INCORRECT CONCLUSIONS OR RESULTS.

7. LIMITATION OF LIABILITY. IN NO EVENT SHALL BUREAU VERITAS TECHNICAL ASSESSMENTS LLC BE LIABLE FOR LATENT OR HIDDEN CONDITIONS, CONDITIONS NOT ACTUALLY OBSERVED BY BUREAU VERITAS TECHNICAL ASSESSMENTS LLC WITHIN THE LIMITED SCOPE OF WORK, THE POTENTIAL CONSEQUENCES OF OBSERVABLE CONDITIONS, CONDITIONS OF WHICH CLIENT HAD KNOWLEDGE OF AT THE TIME OF THE ASSESSMENT, OR ANY UNAUTHORIZED ASSIGNMENT OF OR RELIANCE UPON THE REPORTS. THE LIABILITY OF BUREAU VERITAS TECHNICAL ASSESSMENTS LLC, AND THAT OF ITS OFFICERS, DIRECTORS, EMPLOYEES, AGENTS AND SUBCONTRACTORS, TO CLIENT OR TO ANY THIRD PARTY, INCLUDING ANY COMPANY AFFILIATED WITH SUCH PARTIES, OR ANY OFFICER, DIRECTOR, EMPLOYEE, AGENT, SUBCONTRACTOR, SUCCESSOR, OR ASSIGN OF SUCH PARTIES, FOR ANY LOSSES, WHETHER IN CONTRACT OR TORT (INCLUDING NEGLIGENCE AND STRICT LIABILITY), RELATED TO THE SERVICES, THE AGREEMENT OR OTHERWISE, SHALL NOT EXCEED AN AGGREGATE OF \$25,000.00 PER PROJECT. IN NO EVENT SHALL BUREAU VERITAS TECHNICAL ASSESSMENTS LLC BE LIABLE TO CLIENT FOR ANY EXEMPLARY, PUNITIVE, INDIRECT, INCIDENTAL, SPECIAL, OR CONSEQUENTIAL DAMAGES (INCLUDING LOST PROFITS) ARISING FROM OR IN ANY WAY CONNECTED WITH ITS PERFORMANCE OR FAILURE TO PERFORM UNDER THE AGREEMENT, EVEN IF THE AFFECTED PARTY HAS KNOWLEDGE OF THE POSSIBILITY OF SUCH DAMAGES.
8. WAIVER OF JURY TRIAL. THE CLIENT AND BUREAU VERITAS TECHNICAL ASSESSMENTS LLC HEREBY KNOWINGLY, VOLUNTARILY AND IRREVOCABLY WAIVE ANY AND ALL RIGHTS TO A TRIAL BY JURY IN ANY ACTION, PROCEEDING, CLAIM, OR COUNTERCLAIM, WHETHER IN CONTRACT OR TORT, AT LAW OR IN EQUITY, ARISING OUT OF OR IN ANY WAY RELATED TO THE SERVICES OR THIS AGREEMENT.
9. RELIANCE AND ASSIGNMENT. BUREAU VERITAS TECHNICAL ASSESSMENTS LLC'S WRITTEN REPORT SHALL CONTAIN BUREAU VERITAS TECHNICAL ASSESSMENTS LLC'S STANDARD RELIANCE LANGUAGE UNLESS ALTERNATE LANGUAGE HAS BEEN PRE-APPROVED BY THE CLIENT AND BUREAU VERITAS TECHNICAL ASSESSMENTS LLC. IF NO PRE-APPROVED ALTERNATE LANGUAGE EXISTS, THE SERVICES, THE REPORTS AND OTHER RELATED WORK PRODUCT PROVIDED BY BUREAU VERITAS TECHNICAL ASSESSMENTS LLC MAY BE RELIED UPON BY THE CLIENT, ITS SUCCESSORS AND ASSIGNS WITH RESPECT TO A LOAN SECURED BY THE SUBJECT PROPERTY, AND ANY RATING AGENCY RATING, OR ANY ISSUER OR PURCHASER OF, ANY SECURITY COLLATERALIZED OR OTHERWISE BACKED BY SUCH LOAN. NO OTHER PERSON OR ENTITY MAY RELY ON THE REPORT WITHOUT THE ADVANCE WRITTEN CONSENT OF BUREAU VERITAS TECHNICAL ASSESSMENTS LLC, AND NO OTHER THIRD-PARTY BENEFICIARIES ARE INTENDED. EXCEPT AS DESCRIBED ABOVE, THE CLIENT SHALL NOT ASSIGN THE PROPOSAL, ANY REPORT OR ANY RELATED WORK PRODUCT, WITHOUT THE PRIOR WRITTEN CONSENT OF BUREAU VERITAS TECHNICAL ASSESSMENTS LLC. ANY UNAUTHORIZED REUSE OR REDISTRIBUTION OF BUREAU VERITAS TECHNICAL ASSESSMENTS LLC'S WORK PRODUCT OR REPORTS SHALL BE AT THE CLIENT'S AND RECIPIENT'S SOLE RISK, WITHOUT LIABILITY TO BUREAU VERITAS TECHNICAL ASSESSMENTS LLC. CLIENT WILL HOLD BUREAU VERITAS TECHNICAL ASSESSMENTS LLC HARMLESS FROM ANY AND ALL LIABILITY, OBLIGATION, COST AND EXPENSE ARISING FROM OR RELATED TO ANY UNAUTHORIZED DISTRIBUTION OR USE BY CLIENT OF BUREAU VERITAS TECHNICAL ASSESSMENTS LLC'S WORK PRODUCT OR REPORTS. BUREAU VERITAS TECHNICAL ASSESSMENTS LLC SHALL NOT ASSIGN ITS OBLIGATIONS UNDER THE PROPOSAL; HOWEVER, BUREAU VERITAS TECHNICAL ASSESSMENTS LLC MAY EMPLOY, BY SUBCONTRACT, SUITABLY TRAINED PERSONS OR ENTITIES ACCEPTABLE TO BUREAU VERITAS TECHNICAL ASSESSMENTS LLC TO PERFORM THE SERVICES.
10. Confidentiality. Bureau Veritas Technical Assessments LLC shall not disclose information regarding the Proposal, the Services or any Documents, except to the Client, employees, consultants, subcontractors, or other persons engaged by Bureau Veritas Technical Assessments LLC to perform the Services, third parties designated by the Client (subject to the reliance limitations described herein), or as required by law. Notwithstanding the terms of this Section, Bureau Veritas Technical Assessments LLC shall comply with all judicial orders, government directives, and laws, regulations and ordinances, regarding the reporting to appropriate public agencies of potential dangers to public health, safety or the environment.
11. Miscellaneous. Bureau Veritas Technical Assessments LLC is an independent contractor of Client, and not Client's agent, employee or partner. The Agreement shall be governed by the laws of the State of Maryland and the parties irrevocably consent to the jurisdiction of the courts of the State of Maryland and of the United States District Court for the District of Maryland, if a basis for federal jurisdiction exists. In the event a dispute relating to an Bureau Veritas Technical Assessments LLC report results in litigation, and the claimant does not prevail at trial, then the claimant shall pay all costs incurred by Bureau Veritas Technical Assessments LLC in the defense of the claim, including reasonable attorney's fees. Each provision of the Agreement shall be considered separable, and if, for any reason, any provision or provisions herein are determined to be invalid and contrary to any existing or future law, such invalidity shall not affect those portions of this Agreement that are valid. This Agreement constitutes the entire agreement, and supersedes all prior agreements and understandings, both written and oral, between the parties with respect to the Services to be provided pursuant to this Agreement. The provisions of the Agreement may only be modified by a written instrument signed by an authorized representative of each party.







# CERTIFICATE OF LIABILITY INSURANCE

DATE(MM/DD/YYYY)  
12/22/2023

DPR 2024-0001

THIS CERTIFICATE IS ISSUED AS A MATTER OF INFORMATION ONLY AND CONFERS NO RIGHTS UPON THE CERTIFICATE HOLDER. THIS CERTIFICATE DOES NOT AFFIRMATIVELY OR NEGATIVELY AMEND, EXTEND OR ALTER THE COVERAGE AFFORDED BY THE POLICIES BELOW. THIS CERTIFICATE OF INSURANCE DOES NOT CONSTITUTE A CONTRACT BETWEEN THE ISSUING INSURER(S), AUTHORIZED REPRESENTATIVE OR PRODUCER, AND THE CERTIFICATE HOLDER.

**IMPORTANT:** If the certificate holder is an ADDITIONAL INSURED, the policy(ies) must have ADDITIONAL INSURED provisions or be endorsed. If SUBROGATION IS WAIVED, subject to the terms and conditions of the policy, certain policies may require an endorsement. A statement on this certificate does not confer rights to the certificate holder in lieu of such endorsement(s).

<b>PRODUCER</b> Aon Risk Services Northeast, Inc. Aon Risk Services Northeast, Inc. NY NY Office One Liberty Plaza 165 Broadway, Suite 3201 New York NY 10006 USA	<b>CONTACT NAME:</b> PHONE (A/C. No. Ext): 866-283-7122      FAX (A/C. No.): (800) 363-0105	
	<b>E-MAIL ADDRESS:</b>	
<b>INSURED</b> Bureau Veritas Technical Assessments LLC 6021 University Blvd. Stes. 200-210 Ellicott City MD 21043 USA	<b>RECEIVED</b> <b>JAN 31 2024</b>	
	<b>INSURER(S) AFFORDING COVERAGE</b>	
	INSURER A:	Hartford Fire Insurance Co.      19682
	INSURER B:	Allianz Global Risks US Insurance Co.      35300
	INSURER C:	Trumbull Insurance Company      27120
	INSURER D:	
	INSURER E:	
	INSURER F:	

CITY CLERK'S OFFICE

COVERAGES      CERTIFICATE NUMBER: 570103172778      REVISION NUMBER:

THIS IS TO CERTIFY THAT THE POLICIES OF INSURANCE LISTED BELOW HAVE BEEN ISSUED TO THE INSURED NAMED ABOVE FOR THE POLICY PERIOD INDICATED. NOTWITHSTANDING ANY REQUIREMENT, TERM OR CONDITION OF ANY CONTRACT OR OTHER DOCUMENT WITH RESPECT TO WHICH THIS CERTIFICATE MAY BE ISSUED OR MAY PERTAIN, THE INSURANCE AFFORDED BY THE POLICIES DESCRIBED HEREIN IS SUBJECT TO ALL THE TERMS, EXCLUSIONS AND CONDITIONS OF SUCH POLICIES. LIMITS SHOWN MAY HAVE BEEN REDUCED BY PAID CLAIMS.      Limits shown are as requested

INSR LTR	TYPE OF INSURANCE	ADDL INSD	SUBR WVD	POLICY NUMBER	POLICY EFF (MM/DD/YYYY)	POLICY EXP (MM/DD/YYYY)	LIMITS
B	<input checked="" type="checkbox"/> COMMERCIAL GENERAL LIABILITY <input type="checkbox"/> CLAIMS-MADE <input checked="" type="checkbox"/> OCCUR  GEN'L AGGREGATE LIMIT APPLIES PER: <input type="checkbox"/> POLICY <input checked="" type="checkbox"/> PRO-JECT <input checked="" type="checkbox"/> LOC OTHER:			USL00159324	01/01/2024	01/01/2025	EACH OCCURRENCE \$2,000,000 DAMAGE TO RENTED PREMISES (Ea occurrence) \$1,000,000 MED EXP (Any one person) \$10,000 PERSONAL & ADV INJURY \$2,000,000 GENERAL AGGREGATE \$2,000,000 PRODUCTS - COMP/OP AGG \$2,000,000
A	AUTOMOBILE LIABILITY <input checked="" type="checkbox"/> ANY AUTO <input type="checkbox"/> OWNED AUTOS ONLY <input type="checkbox"/> SCHEDULED AUTOS <input type="checkbox"/> HIRED AUTOS ONLY <input type="checkbox"/> NON-OWNED AUTOS ONLY			10 AB S41202 AOS	01/01/2024	01/01/2025	COMBINED SINGLE LIMIT (Ea accident) \$2,000,000 BODILY INJURY (Per person) BODILY INJURY (Per accident) PROPERTY DAMAGE (Per accident)
B	<input checked="" type="checkbox"/> UMBRELLA LIAB <input checked="" type="checkbox"/> OCCUR <input type="checkbox"/> EXCESS LIAB <input type="checkbox"/> CLAIMS-MADE DED <input checked="" type="checkbox"/> RETENTION \$10,000			USL00163324	01/01/2024	01/01/2025	EACH OCCURRENCE \$1,000,000 AGGREGATE \$1,000,000
C	WORKERS COMPENSATION AND EMPLOYERS' LIABILITY ANY PROPRIETOR / PARTNER / EXECUTIVE OFFICER/MEMBER EXCLUDED? (Mandatory in NH) If yes, describe under DESCRIPTION OF OPERATIONS below		Y/N N/A	10WNS41200 See State Policy Addendum	01/01/2024	01/01/2025	<input checked="" type="checkbox"/> PER STATUTE <input type="checkbox"/> OTH-ER E.L. EACH ACCIDENT \$1,000,000 E.L. DISEASE-EA EMPLOYEE \$1,000,000 E.L. DISEASE-POLICY LIMIT \$1,000,000
B	Architects & Engineers Professional			USF00248024 Claims Made SIR applies per policy terms & conditions	01/01/2024	01/01/2025	Each Claim \$1,000,000 Aggregate \$1,000,000

DESCRIPTION OF OPERATIONS / LOCATIONS / VEHICLES (ACORD 101, Additional Remarks Schedule, may be attached if more space is required)  
Evidence of insurance. The Architects & Engineers policy includes coverage for Professional Liability and Contractors Pollution Liability. Certificate Holder is included as Additional Insured in accordance with the policy provisions of the General Liability Coverage policy.

## CERTIFICATE HOLDER

## CANCELLATION

City of Spokane 808 W. Spokane Falls Blvd. Spokane WA 99256 USA	SHOULD ANY OF THE ABOVE DESCRIBED POLICIES BE CANCELLED BEFORE THE EXPIRATION DATE THEREOF, NOTICE WILL BE DELIVERED IN ACCORDANCE WITH THE POLICY PROVISIONS.  AUTHORIZED REPRESENTATIVE  <i>Aon Risk Services Northeast, Inc.</i>
---	---

©1988-2015 ACORD CORPORATION. All rights reserved.

Holder Identifier :

Certificate No : 570103172778

**ADDITIONAL REMARKS SCHEDULE**

AGENCY Aon Risk Services Northeast, Inc.		NAMED INSURED Bureau Veritas Technical Assessments LLC	
POLICY NUMBER See Certificate Number: 570103172778			
CARRIER See Certificate Number: 570103172778	NAIC CODE	EFFECTIVE DATE:	

**ADDITIONAL REMARKS****THIS ADDITIONAL REMARKS FORM IS A SCHEDULE TO ACORD FORM,****FORM NUMBER:** ACORD 25 **FORM TITLE:** Certificate of Liability Insurance

Workers Compensation/Employers Liability

10WNS41200 01/01/24-01/01/25 Trumbull Insurance AR,DC,IN,LA,NE,RI,UT  
 10WNS41200 01/01/24-01/01/25 Twin City Fire Insurance Company FL,ND,OH,WA,WY  
 10WNS41200 01/01/24-01/01/25 Hartford Insurance Company of the Midwest AK,ID  
 10WNS41200 01/01/24-01/01/25 Hartford Casualty Insurance Company MO,WV  
 10WNS41200 01/01/24-01/01/25 Nutmeg Insurance Company CT,IL  
 10WNS41200 01/01/24-01/01/25 Hartford Fire Insurance Company NH,OR,PA  
 10WNS41200 01/01/24-01/01/25 Hartford Accident and Indemnity Company AL,GA,KY,MI,MT,NY,TN,VT  
 10WNS41200 01/01/24-01/01/25 Property & Casualty Ins Co of Hartford CA,CO,DE,ME, MN,MS,SC  
 10WNS41200 01/01/24-01/01/25 Hartford Insurance Company of Illinois TX  
 10WNS41200 01/01/24-01/01/25 Hartford Insurance Company of the Southeast KS,MD  
 10WNS41200 01/01/24-01/01/25 Hartford Underwriters Insurance Company AZ,HI, NC,NJ,SD,VA  
 10WNS41200 01/01/24-01/01/25 Sentinel Insurance Company, Limited IA,NM,NV,OK  
 10WBRS41201 01/01/24-01/01/25 Twin City Fire Insurance Company WI  
 10WBRS41201 01/01/24-01/01/25 Hartford Underwriters Insurance Company MA  
 10WBRS41201 01/01/24-01/01/25 Hartford Fire Insurance Company PR

MSC#17755  
Aon Risk Services  
PO Box 1447  
Lincolnshire, IL 60069

MDG2024 00015735 01



City of Spokane  
808 W. Spokane Falls Blvd.  
Spokane WA 99256



Certificate No: 570103172778



City of Spokane  
808 W. Spokane Falls Blvd.  
Spokane WA 99256 USA

Friday, January 5, 2024

**To whom it may concern:**

Following a concentrated effort to reduce our environmental footprint and provide timely certificate delivery, Aon will begin delivering our Certificates of Insurance electronically in PDF format.

Please utilize one of the following methods to ensure you will receive the electronic copy of your Certificate (Certificate No: **570103172778**) for future renewals:

- Visit [aon.com/e-cert](https://aon.com/e-cert); or
- Utilize the QR Code below to enter/validate your information.

If your email address has changed or will be changing in the future, or you no longer require this certificate, please let us know using one of the methods above.

Thank you for your cooperation and willingness to help us reduce our impact to the environment.

MSC# 17755 | Aon  
P.O. Box 1447  
Lincolnshire, IL 60069



**Agenda Sheet for City Council:****Committee:** PIES **Date:** 05/20/2024**Committee Agenda type:** Consent**Date Rec'd**

5/20/2024

**Clerk's File #**

OPR 2024-0464

**Cross Ref #****Project #****Council Meeting Date:** 06/10/2024**Submitting Dept**

FACILITIES MANAGEMENT

**Bid #**

IPWQ #6104-24

**Contact Name/Phone**

DAVE STEELE 625-6040

**Requisition #****Contact E-Mail**

DSTEELE@SPOKANECITY.ORG

**Agenda Item Type**

Contract Item

**Council Sponsor(s)**

BWILKERSON JBINGLE KKLITZKE

**Agenda Item Name**

5900 2024 ANNUAL ASPHALT MAINT &amp; REPAIR CONTRACT - ARROW

**Agenda Wording**

The Facilities Department partners with Purchasing to release a request for bids for maintenance, repair, striping, etc of City owned parking lots.

**Summary (Background)**

This contract is typically formatted as "not to exceed" a specific threshold. This season, the not to exceed amount is \$300,000.00. with the work being distributed between multiple parks, library, fire and solid waste parking lots.

Lease? NO Grant related? NO Public Works? YES

**Fiscal Impact**

Approved in Current Year Budget? YES

Total Cost \$ 300,000.00

Current Year Cost \$ 300,000.00

Subsequent Year(s) Cost \$

**Narrative****Amount****Budget Account**

Expense \$ 275,000.00

# 5900-71300-42650-54201-99999

Expense \$ 25,000.00

# 4500-45700-37148-54801-99999

Select \$

#

Select \$

#

\$

#

\$

#



## Continuation of Wording, Summary, Approvals, and Distribution

### Agenda Wording

### Summary (Background)

#### **Approvals**

<b><u>Dept Head</u></b>	TEAL, JEFFREY	<b><u>PURCHASING</u></b>	PRINCE, THEA
<b><u>Division Director</u></b>	BOSTON, MATTHEW		
<b><u>Accounting Manager</u></b>	BUSTOS, KIM		
<b><u>Legal</u></b>	SCHOEDEL, ELIZABETH		
<b><u>For the Mayor</u></b>	PICCOLO, MIKE		

#### **Additional Approvals**

#### **Distribution List**

	jeffh@asphaltsupply.net
kbustos@spokanecity.org	araska@asphaltsupply.net
facilitiesdepartment@spokanecity.org	laga@spokanecity.org
tprince@spokanecity.org	jsalstrom@spokanecity.org

## Committee Agenda Sheet

### Public Infrastructure, Environment & Sustainability Committee

<b>Submitting Department</b>	Facilities
<b>Contact Name</b>	Dave Steele
<b>Contact Email &amp; Phone</b>	509-625-6064
<b>Council Sponsor(s)</b>	CP Wilkerson, CM Bingle, CM Klitzke
<b>Select Agenda Item Type</b>	<input checked="" type="checkbox"/> Consent <input type="checkbox"/> Discussion    Time Requested:
<b>Agenda Item Name</b>	Annual Asphalt Maintenance & Repair Annual Contract – Arrow Concrete
<b>Summary (Background)</b>  *Use the Fiscal Impact box below for relevant financial information	Each asphalt season, the Facilities Department in partnership with Purchasing releases a request for bids for the maintenance, repair, striping, etc. of City owned parking lots. This contract is typically formatted as ‘not to exceed’ a specific threshold. This season, the not to exceed amount is \$300,000 with the work being distributed between multiple Parks, Library, Fire and Solid Waste parking lots.
<b>Proposed Council Action</b>	Contract approval
<b>Fiscal Impact</b> Total Expense: <u>Not to exceed \$300,000</u> Approved in current year budget? <input checked="" type="checkbox"/> Yes <input type="checkbox"/> No <input type="checkbox"/> N/A  Funding Source <input checked="" type="checkbox"/> One-time <input type="checkbox"/> Recurring <input type="checkbox"/> N/A Specify funding source: <a href="#">Click or tap here to enter text.</a>  Expense Occurrence <input checked="" type="checkbox"/> One-time <input type="checkbox"/> Recurring <input type="checkbox"/> N/A  Other budget impacts: (revenue generating, match requirements, etc.) Reduction of long term replacement costs by completing proper ongoing maintenance.	
<b>Operations Impacts (If N/A, please give a brief description as to why)</b>	
What impacts would the proposal have on historically excluded communities?  <p style="text-align: center;">NA – This work focuses on providing access to core City functions but does not provide any significant new opportunities.</p>	
How will data be collected, analyzed, and reported concerning the effect of the program/policy by racial, ethnic, gender identity, national origin, income level, disability, sexual orientation, or other existing disparities?  <p style="text-align: center;">NA – This work focuses on providing access to core City functions but does not provide any significant new opportunities.</p>	

How will data be collected regarding the effectiveness of this program, policy, or product to ensure it is the right solution?

NA – Ongoing maintenance is generally accepted as the best way to reduce long term replacement costs by completing proper ongoing maintenance.

Describe how this proposal aligns with current City Policies, including the Comprehensive Plan, Sustainability Action Plan, Capital Improvement Program, Neighborhood Master Plans, Council Resolutions, and others?

NA – Reduction of long term replacement costs by completing proper ongoing maintenance.





**City of Spokane**

**PREVENTATIVE MAINTENANCE  
AGREEMENT**

**Title: 2024 OFF-STREET PARKING LOT  
REPAIR AND MAINTENANCE**

This Agreement is made and entered into by and between the **CITY OF SPOKANE** as ("City"), a Washington municipal corporation, and **ARROW CONCRETE & ASPHALT SPECIALTIES**, whose address is 9915 East Trent Avenue, Spokane Valley, Washington 99206 as ("Contractor"), individually hereafter referenced as a "party", and together as the "parties".

*WHEREAS, the purpose of this Agreement is to provide 2024 Off-Street Parking Lot Repair and Maintenance; and*

*WHEREAS, the Contractor was selected from IPWQ No. 6104-24.*

*NOW, THEREFORE, in consideration of the terms, conditions, covenants and performance of the Scope of Work contained herein, the City and Contractor mutually agree as follows:*

**1. TERM OF AGREEMENT.**

The term of this Agreement begins on June 1, 2024, and ends on May 31, 2025, unless amended by written agreement or terminated earlier under the provisions.

**2. TIME OF BEGINNING AND COMPLETION.**

The Contractor shall begin the work outlined in the "Scope of Work" ("Work") on the beginning date, above. The City will acknowledge in writing when the Work is complete. Time limits established under this Agreement shall not be extended because of delays for which the Contractor is responsible, but may be extended by the City, in writing, for the City's convenience or conditions beyond the Contractor's control.

**3. SCOPE OF WORK.**

The Contractor's General Scope of Work for this Agreement is described in the City's IPWQ and Contractor's Response which is attached as Exhibit C and made a part of this Agreement. In the event of a conflict or discrepancy in the Agreement documents, this City Agreement controls.

The Work is subject to City review and approval. The Contractor shall confer with the City periodically and prepare and present information and materials (e.g. detailed outline of completed Work) requested by the City to determine the adequacy of the Work or Contractor's progress.

**4. COMPENSATION / PAYMENT.**

Total compensation for Contractor's services under this unit priced Agreement shall be a maximum amount not to exceed **THREE HUNDRED THOUSAND AND NO/100 DOLLARS (\$300,000.00)**, plus applicable taxes, and in accordance with the Pricing Response in Exhibit C, unless modified by a written amendment to this Agreement. This is the maximum amount to be

paid under this Agreement for the work described in Section 3 above and shall not be exceeded without the prior written authorization of the City in the form of an executed amendment to this Agreement.

The Contractor shall submit its applications for payment to City of Spokane Facilities Management Department, [facilitiesdepartment@spokanecity.org](mailto:facilitiesdepartment@spokanecity.org), Attn: Dave Steele. All invoices should include the City Clerk's File No. "OPR XXXX-XXXX" and an approved L & I Intent to Pay Prevailing Wage number. The final invoice should include an approved Affidavit of Wages Paid number. Payment will not be made without this documentation included on the invoice. **Payment will be made via direct deposit/ACH** within thirty (30) days after receipt of the Company's application except as provided by state law. If the City objects to all or any portion of the invoice, it shall notify the Company and reserves the right to only pay that portion of the invoice not in dispute. In that event, the parties shall immediately make every effort to settle the disputed amount.

#### **5. TAXES, FEES AND LICENSES.**

- A. Contractor shall pay and maintain in current status, all necessary licenses, fees, assessments, permit charges, etc. necessary to conduct the work included under this Agreement. It is the Contractor's sole responsibility to monitor and determine changes or the enactment of any subsequent requirements for said fees, assessments, or changes and to immediately comply.
- B. The cost of any permits, licenses, fees, etc. arising as a result of the projects included in this Agreement shall be included in the project budgets.

#### **6. PREVENTATIVE MAINTENANCE.**

The following Preventative Maintenance requirements apply to the Work under this Agreement:

- A. The Contractor shall pay state prevailing wages. The Contractor and all subcontractors will submit a "Statement of Intent to Pay Prevailing Wages," certified by the industrial statistician of the Department of Labor and Industries, prior to any payments. The "Statement of Intent to Pay Prevailing Wages" shall include: (1) the Contractor's registration number; and (2) the prevailing wages under RCW 39.12.020 and the number of workers in each classification. Each voucher claim submitted by a Contractor for payment on a project estimate shall state that the prevailing wages have been paid in accordance with the pre-filed statement or statements of intent to pay prevailing wages on file with the City. At the end of the work, the Contractor and subcontractors must submit an "Affidavit of Wages Paid," certified by the industrial statistician.
- B. **STATEMENT OF INTENT TO PAY PREVAILING WAGES TO BE POSTED.** For contracts in excess of \$10,000, the Contractor and each subcontractor required to pay the prevailing rate of wages shall post in a location readily visible at the job site: (1) a copy of a "Statement of Intent to Pay Prevailing Wages" approved by the industrial statistician of the Washington State Department of Labor and Industries (L & I); and (2) the address and telephone number of the industrial statistician of the Department of Labor and Industries where a complaint or inquiry concerning prevailing wages may be made.
- C. A payment/performance bond is NOT required.
- D. Statutory retainage is NOT required.

#### **7. CITY OF SPOKANE BUSINESS LICENSE.**

Section 8.01.070 of the Spokane Municipal Code states that no person may engage in business with the City without first having obtained a valid annual business registration. The Contractor shall be responsible for contacting the State of Washington Business License Services at

www.dor.wa.gov or 360-705-6741 to obtain a business registration. If the Contractor does not believe it is required to obtain a business registration, it may contact the City's Taxes and Licenses Division at (509) 625-6070 to request an exemption status determination.

## **8. SOCIAL EQUITY REQUIREMENTS / NON-DISCRIMINATION.**

No individual shall be excluded from participation in, denied the benefit of, subjected to discrimination under, or denied employment in the administration of or in connection with this Agreement because of age, sex, race, color, religion, creed, marital status, familial status, sexual orientation including gender expression or gender identity, national origin, honorably discharged veteran or military status, the presence of any sensory, mental or physical disability, or use of a service animal by a person with disabilities. The Contractor agrees to comply with, and to require that all subcontractors comply with, federal, state and local nondiscrimination laws, including but not limited to: the Civil Rights Act of 1964, the Rehabilitation Act of 1973, the Age Discrimination in Employment Act, and the American's With Disabilities Act, to the extent those laws are applicable.

## **9. INDEMNIFICATION.**

The Contractor shall defend, indemnify, and hold the City and its officers and employees harmless from all claims, demands, or suits at law or equity—asserted by third parties for bodily injury (including death) and/or property damage which arise from the Contractor's negligence or willful misconduct under this Agreement, including attorneys' fees and litigation costs; provided that nothing herein shall require a Contractor to indemnify the City against and hold harmless the City from claims, demands or suits based solely upon the negligence of the City, its agents, officers, and employees. If a claim or suit is caused by or results from the concurrent negligence of the Contractor's agents or employees and the City, its agents, officers and employees, this indemnity provision shall be valid and enforceable to the extent of the negligence of the Contractor, its agents or employees. The Contractor specifically assumes liability and agrees to defend, indemnify, and hold the City harmless for actions brought by the Contractor's own employees against the City and, solely for the purpose of this indemnification and defense, the Contractor specifically waives any immunity under the Washington State industrial insurance law, or Title 51 RCW. The Consultant/Contractor/Company recognizes that this waiver was specifically entered into pursuant to the provisions of RCW 4.24.115 and was the subject of mutual negotiation. The indemnity and agreement to defend and hold the City harmless provided for in this section shall survive any termination or expiration of this agreement.

## **10. INSURANCE.**

During the period of the Agreement, the Contractor shall maintain in force at its own expense, each insurance noted below with companies or through sources approved by the State Insurance Commissioner pursuant to Title 48 RCW:

A. **Worker's Compensation Insurance** in compliance with RCW 51.12.020, which requires subject employers to provide workers' compensation coverage for all their subject workers and Employer's Liability Insurance in the amount of \$1,000,000;

B. **General Liability Insurance** on an occurrence basis, with a combined single limit of not less than \$1,000,000 each occurrence for bodily injury and property damage. It shall include contractual liability coverage for the indemnity provided under this agreement. It shall provide that the City, its officers and employees are additional insureds but only with respect to the Contractor's services to be provided under this Agreement;

C. **Automobile Liability Insurance** with a combined single limit, or the equivalent of not less than \$1,000,000 each accident for bodily injury and property damage, including coverage for owned, hired and non-owned vehicles; and

D. **Property Insurance** if materials and supplies are furnished by the Contractor. The amount of the insurance coverage shall be the value of the materials and supplies of the completed value of improvement. Hazard or XCU (explosion, collapse, underground) insurance should be provided if any hazard exists.

There shall be no cancellation, material change, reduction of limits or intent not to renew the insurance coverage(s) without sixty (60) days written notice from the Contractor or its insurer(s) to the City. As evidence of the insurance coverages required by this Agreement, the Contractor shall furnish acceptable insurance certificates to the City at the time it returns the signed Agreement. The certificate shall specify all of the parties who are additional insureds, and include applicable policy endorsements, the sixty (60) day cancellation clause, and the deduction or retention level. The Contractor shall be financially responsible for all pertinent deductibles, self-insured retentions, and/or self-insurance.

#### **11. SUBCONTRACTOR RESPONSIBILITY.**

The Contractor must verify responsibility criteria for each first-tier subcontractor, and a subcontractor of any tier that hires other subcontractors must verify responsibility criteria for each of its subcontractors. Verification shall include that each subcontractor, at the time of subcontract execution, meets the responsibility criteria listed in RCW 39.04.350(1) and possesses an electrical contractor license, if required by chapter 19.28 RCW, or an elevator contractor license, if required by chapter 70.87 RCW.

#### **12. INDEPENDENT CONTRACTOR.**

The Contractor is an independent Contractor. This Agreement does not intend the Contractor to act as a City employee. The City has neither direct nor immediate control over the Contractor nor the right to control the manner or means by which the Contractor works. Neither the Contractor nor any Contractor employee shall be an employee of the City. This Agreement prohibits the Contractor to act as an agent or legal representative of the City. The Contractor is not granted express or implied rights or authority to assume or create any obligation or responsibility for or in the name of the City, or to bind the City. The City is not liable for or obligated to pay sick leave, vacation pay, or any other benefit of employment, nor to pay social security or other tax that may arise from employment. The Contractor shall pay all income and other taxes as due.

#### **13. ASSIGNMENT AND SUBCONTRACTING.**

The Contractor shall not assign or subcontract its obligations under this Agreement without the City's written consent, which may be granted or withheld in the City's sole discretion. Any subcontract made by the Contractor shall incorporate by reference this Agreement, except as otherwise provided. The Contractor shall ensure that all subcontractors comply with the obligations and requirements of the subcontract. The City's consent to any assignment or subcontract does not release the Contractor from liability or any obligation within this Agreement, whether before or after City consent, assignment or subcontract.

#### **14. TERMINATION.**

Either party may terminate this Agreement, with or without cause, by ten (10) days written notice to the other party. In the event of such termination, the City shall pay the Contractor for all work previously authorized and performed prior to the termination date.

#### **15. STANDARD OF PERFORMANCE.**

The standard of performance applicable to Contractor's services will be the degree of skill and diligence normally employed by professional contractors in the region performing the same or similar Contracting services at the time the work under this Agreement are performed.

## **16. ANTI KICK-BACK.**

No officer or employee of the City of Spokane, having the power or duty to perform an official act or action related to this Agreement shall have or acquire any interest in the Agreement, or have solicited, accepted or granted a present or future gift, favor, service or other thing of value from or to any person involved in this Agreement.

## **17. CONSTRUAL.**

The Contractor acknowledges receipt of a copy of the Agreement documents and agrees to comply with them. The silence or omission in the Agreement documents concerning any detail required for the proper execution and completion of the work means that only the best general practice is to prevail and that only material and workmanship of the best quality are to be used. This Contract shall be construed neither in favor of nor against either party.

## **18. DEBARMENT AND SUSPENSION.**

The Contractor has provided its certification that it is in compliance with and shall not contract with individuals or organizations which are debarred, suspended, or otherwise excluded from or ineligible from participation in Federal Assistance Programs under Executive Order 12549 and "Debarment and Suspension", codified at 29 CFR part 98.

## **19. CONTRACTOR'S ACKNOWLEDGEMENT AND WARRANTY.**

The Contractor acknowledges that it has visited the site of the work, has examined it, and is qualified to perform the work required by this Agreement.

The Contractor guarantees and warranties all work, labor and materials under this Agreement for one (1) year following final acceptance. If any unsatisfactory condition or defect develops within that time, the Contractor will immediately place the work in a condition satisfactory to the City and repair all damage caused by the condition or defect. The Contractor will repair or restore to the City's satisfaction, in accordance with the contract documents and at its expense, all property damaged by his performance under this Agreement. This warranty is in addition to any manufacturers' or other warranty in the Agreement documents.

## **20. MISCELLANEOUS PROVISIONS.**

- A. **Amendments/Modifications:** The City may modify this Agreement and order changes in the work whenever necessary or advisable. The Contractor will accept modifications when ordered in writing by the City, and the Agreement time and compensation will be adjusted accordingly.
- B. The Contractor, at no expense to the City, shall comply with all laws of the United States and Washington, the Charter and ordinances of the City of Spokane; and rules, regulations, orders and directives of their administrative agencies and officers.
- C. This Agreement shall be construed and interpreted under the laws of Washington. The venue of any action brought shall be in a court of competent jurisdiction, located in Spokane County, Washington.
- D. **Captions:** The titles of sections or subsections are for convenience only and do not define or limit the contents.
- E. **Severability:** If any term or provision is determined by a court of competent jurisdiction to be invalid or unenforceable, the remainder of this Agreement shall not be affected, and each term and provision shall be valid and enforceable to the fullest extent permitted by law.
- F. **Waiver:** No covenant, term or condition or the breach shall be deemed waived, except by written consent of the party against whom the waiver is claimed, and any waiver of the breach of any covenant, term or condition shall not be deemed a waiver of any preceding or succeeding breach of the same or any other covenant, term of condition. Neither the acceptance by the City of any performance by the Contractor after the time the same shall

have become due nor payment to the Contractor for any portion of the Work shall constitute a waiver by the City of the breach or default of any covenant, term or condition unless otherwise expressly agreed to by the City in writing.

- G. **Entire Agreement:** This document along with any exhibits and all attachments, and subsequently issued addenda, comprises the entire agreement between the City and the Contractor. If conflict occurs between Agreement documents and applicable laws, codes, ordinances or regulations, the most stringent or legally binding requirement shall govern and be considered a part of this Agreement to afford the City the maximum benefits.
- H. **No personal liability:** No officer, agent or authorized employee of the City shall be personally responsible for any liability arising under this Agreement, whether expressed or implied, nor for any statement or representation made or in any connection with this Agreement.
- I. Under Washington State Law (reference RCW Chapter 42.56, the *Public Records Act* [PRA]) all materials received or created by the City of Spokane are **public records** and are available to the public for viewing via the City Clerk’s Records (online) or a valid Public Records Request (PRR).

IN WITNESS WHEREOF, in consideration of the terms, conditions and covenants contained, or attached and incorporated and made a part, the parties have executed this Agreement by having legally-binding representatives affix their signatures below.

**ARROW CONCRETE &  
ASPHALT SPECIALTIES**

**CITY OF SPOKANE**

By \_\_\_\_\_  
Signature Date

By \_\_\_\_\_  
Signature Date

\_\_\_\_\_  
Type or Print Name

\_\_\_\_\_  
Type or Print Name

\_\_\_\_\_  
Title

\_\_\_\_\_  
Title

Attest:

Approved as to form:

\_\_\_\_\_  
City Clerk

\_\_\_\_\_  
Assistant City Attorney

**Attachments that are part of this Agreement:**

- Attachment A – Debarment Certification
- Attachment B - Certification of Compliance with Wage Payment Statutes
- Attachment C – Contractor’s Response to IPWQ

**ATTACHMENT A**

**CERTIFICATION REGARDING DEBARMENT, SUSPENSION,  
INELIGIBILITY AND VOLUNTARY EXCLUSION**

1. The undersigned (i.e., signatory for the Subrecipient / Contractor / Consultant) certifies, to the best of its knowledge and belief, that it and its principals:
  - a. Are not presently debarred, suspended, proposed for debarment, declared ineligible, or voluntarily excluded from covered transactions by any federal department or agency;
  - b. Have not within a three-year period preceding this contract been convicted or had a civil judgment rendered against them for commission of fraud or a criminal offense in connection with obtaining, attempting to obtain, or performing a public (federal, state, or local) transaction or contract under a public transaction; violation of federal or state antitrust statutes or commission of embezzlement, theft, forgery, bribery, falsification or destruction of records, making false statements, tax evasion, receiving stolen property, making false claims, or obstruction of justice;
  - c. Are not presently indicted or otherwise criminally or civilly charged by a government entity (federal, state, or local) with commission of any of the offenses enumerated in paragraph (1)(b) of this certification; and,
  - d. Have not within a three-year period preceding this contract had one or more public transactions (federal, state, or local) terminated for cause or default.
2. The undersigned agrees by signing this contract that it shall not knowingly enter into any lower tier covered transaction with a person who is debarred, suspended, declared ineligible, or voluntarily excluded from participation in this covered transaction.
3. The undersigned further agrees by signing this contract that it will include the following clause, without modification, in all lower tier covered transactions and in all solicitations for lower tier covered transactions:

Certification Regarding Debarment, Suspension, Ineligibility and Voluntary Exclusion – Lower Tier Covered Transactions

1. The lower tier contractor certified, by signing this contract that neither it nor its principals is presently debarred, suspended, proposed for debarment, declared ineligible, or voluntarily excluded from participation in this transaction by any federal department or agency.
2. Where the lower tier contractor is unable to certify to any of the statements in this contract, such contractor shall attach an explanation to this contract.

4. I understand that a false statement of this certification may be grounds for termination of the contract.

_____ Name of Subrecipient / Contractor / Consultant (Type or Print)	_____ Program Title (Type or Print)
_____ Name of Certifying Official (Type or Print)	_____ Signature
_____ Title of Certifying Official (Type or Print)	_____ Date (Type or Print)



**ATTACHMENT B**

**Certification of Compliance with Wage Payment Statutes and Washington Department of Labor and Industries Training Requirement**

The bidder hereby certifies that, within the three-year period immediately preceding the bid solicitation date (\_\_\_\_\_), the bidder is not a “willful” violator, as defined in RCW 49.48.082, of any provision of chapters 49.46, 49.48, or 49.52 RCW, as determined by a final and binding citation and notice of assessment issued by the Department of Labor and Industries or through a civil judgment entered by a court of limited or general jurisdiction.

As of July 1, 2019, have fulfilled the Department of Labor and Industries’ Public Works and Prevailing Wage Training Requirement before bidding and/or performing work on public works projects under RCW 39.04.350 and RCW 39.06.020 by either of the following:

- 1) Received training on the requirements related to public works and prevailing wage under chapter RCW 39.04.350 and chapter 39.12; or
- 2) Be certified exempt by the Department of Labor and Industries by having completed three or more public work projects and have a had a valid business license in Washington for three or more years.

I certify under penalty of perjury under the laws of the State of Washington that the foregoing is true and correct.

\_\_\_\_\_  
Bidder’s Business Name

\_\_\_\_\_  
Signature of Authorized Official\*

\_\_\_\_\_  
Printed Name

\_\_\_\_\_  
Title

\_\_\_\_\_  
Date

\_\_\_\_\_  
City

\_\_\_\_\_  
State

Check One:

Sole Proprietorship  Partnership  Joint Venture  Corporation

State of Incorporation, or if not a corporation, State where business entity was formed:

\_\_\_\_\_  
If a co-partnership, give firm name under which business is transacted:

\_\_\_\_\_

*\* If a corporation, proposal must be executed in the corporate name by the president or vice-president (or any other corporate officer accompanied by evidence of authority to sign). If a co-partnership, proposal must be executed by a partner.*



**ATTACHMENT C**

## Bid Response Summary

**Bid Number** IPWQ 6104-24  
**Bid Title** 2024 Off-Street Parking Lot Repair and Maintenance  
**Due Date** Thursday, April 11, 2024 3:00:00 PM [(UTC-08:00) Pacific Time (US & Canada)]  
**Bid Status** Closed to Bidding  
**Company** Arrow Concrete & Asphalt Specialties, LLC  
**Submitted By** Jeff Hohenthal - Wednesday, April 10, 2024 1:54:10 PM [(UTC-08:00) Pacific Time (US & Canada)]  
 jeffh@asphaltsupply.net

**Comments**

**Question Responses**

Group	Reference Number	Question	Response
Default Item Group			
	BACKGROUND	The City of Spokane is seeking a contractor for 2024 Off-Street Parking Lot Repair and Maintenance for the Facilities Department. Services are requested on an as needed basis.	I acknowledge and agree
	CONTRACTOR'S REPRESENTATION	The Contractor by making its Bid represents that it has read and understands the specifications.	I acknowledge and agree
	QUALIFICATION	Prior to the award of Contract, the Contractor shall be required to submit evidence of sufficient facilities, equipment, experience and financial ability to insure completion of the Work, unless waived by the City.	I acknowledge and agree
	AWARD OF CONTRACT	Award of Contract, when made by the City, will be to lowest responsive responsible bidder based on the work outlined in the Scope of Work and Bid Proposal. Unsuccessful Bidders will not automatically be notified of results. The City reserves the right to accept either the base bid per plans and specifications or alternative proposals when in the best interest of the City.	I acknowledge and agree
	EXECUTION OF CONTRACT	Within ten (10) days of contract award, the Contractor shall sign and return to the City an executed copy of the contract and approved evidence of insurance unless otherwise mutually agreed by the City and Contractor.	I acknowledge and agree
	GUARANTEE	The Contractor guarantees all work, labor and materials for one (1) year following final acceptance. If any unsatisfactory condition or defect develops within that time, the Contractor shall immediately place the work in a satisfactory condition, and further repair all damage caused by the condition or defect at its sole expense. This guarantee shall not apply to work which has been abused or neglected by the City.	I acknowledge and agree

INVOICING	Invoices must be submitted to the Facilities Department within 30 days of performing the work. • Invoices shall include the location and type of services performed, detailed hours and rate per hour, and on site contact that approved services. • Invoices shall reference and list OPR #2024-XXXX and approved Intent to Pay Prevailing Wage Number. • Payment of invoices shall be contingent upon receipt of sufficient detail to permit identification of the services performed and compliance with contract conditions. Original invoices are required and shall not be approved for payment until all services per request have been satisfactorily performed. Invoices shall be mailed to the Facilities Department, 221 West First Avenue, Third Floor, Spokane WA 99201	I acknowledge and agree
PAYMENT	Payment will be made via direct deposit/ACH after receipt of the Contractor's application except as provided by state law. If the City objects to all or any portion of the invoice, it shall notify the Contractor and reserves the right to only pay that portion of the invoice not in dispute. In that event, the parties shall immediately make every effort to settle the disputed amount.	I acknowledge and agree
REJECTION OF BIDS	The City reserves the right to reject any or all Bids, to waive minor deviations from the specifications, to waive minor informalities in Bid process whenever it is in the City's best interest, and to accept or reject all or part of this Request for Bids, at the prices shown.	I acknowledge and agree
CONTRACTOR REGISTRATION	The Contractor shall be a Washington State registered or licensed contractor at time of Bid submittal.	I acknowledge and agree
RECIPROCAL PREFERENCE FOR RESIDENT CONTRACTORS	A. In accordance with RCW 39.04.380 effective March 30, 2012 the City of Spokane is enforcing a Reciprocal Preference for Resident Contractors. Any public works bid received from a nonresident Contractor from a state that provides an in-state percentage bidding preference, a comparable percentage disadvantage must be applied to the bid of that nonresident Contractor. A nonresident Contractor from a state that provides a percentage bid preference means a Contractor that: a) is from a state that provides a percentage bid preference to its resident Contractors bidding on public works Contracts; and b) at the time of bidding on a public works project, does not have a physical office located in Washington.	I acknowledge and I agree
RECIPROCAL PREFERENCE FOR RESIDENT CONTRACTORS	B. The state of residence for a nonresident Contractor is the state in which the Contractor was incorporated or, if not a corporation, the state where the Contractor's business entity was formed. All nonresident Contractors will be evaluated for out of state Bidder preference. If the state of the nonresident Contractor provides an in-state Contractor preference, a comparable percentage disadvantage will be applied to their bid prior to Contract award.	I acknowledge and I agree
RECIPROCAL PREFERENCE FOR RESIDENT CONTRACTORS	C. This section does not apply to public works procured pursuant to RCW 39.04.155, 39.04.280, or any other procurement exempt from competitive bidding.	I acknowledge and I agree

COMPLETION TIME	Work must be completed in a reasonable amount of time, contractor cannot leave our work incomplete to go to another job. If repair is delayed due to needed parts, estimated wait time and shipping tracking information must be provided. If for any reason the contractor is unable to respond in a reasonable amount of time, the City reserves the right to go outside the contract and work with another contractor.	I acknowledge and agree
EMPLOYEES PER JOB	Please indicate how many employees the contractor feels is standard to perform each job.	Varies by scope of work
LIQUIDATED DAMAGES	If individual task assignments are not completed within the stated completion time as defined in the task assignment, the Contractor agrees to pay to the City Liquidated Damages (LD's) in the amount of TWO HUNDRED FIFTY DOLLARS (\$250.00) for each and every day the Work on that task assignment remains uncompleted.	I acknowledge and agree
CONTRACTOR CONTACT INFORMATION	Please indicate Name, Telephone Number and E-Mail address for person submitting this bid response.	Jeff Hohenthal jeffh@asphaltsupply.net 509-279-8125 9915 E Trent Avenue, Spokane Valley, WA 99206
EXCEPTIONS	If you marked "I do not acknowledge and agree" on any of the areas above, explain here what you are taking exception to.	n/a
ADDITIONAL INFORMATION	If you have additional information/documents to submit, upload them here.	IPWQ #6104-24 IPWQ #5864-23 Supplemental Bidder Responsibility Criteria Form 1.pdf
FACILITIES PROJECT COORDINATION REQUIREMENT	With the intent of providing highly efficient and effective customer service to City Departments and streamlined project management for the Contractor while under contract, the City of Spokane Facilities Department has established the following site visitation scheduling procedures: 1) All Contractor communications shall be directed to the Facilities Department Project Coordinator via email. Contact information is identified in the contract documents. 2) Contractors and subcontractors shall not visit a project site unannounced. Visits shall be scheduled and confirmed through email with the Facilities Department Project Coordinator. a. Requests shall be made a minimum of 2 business days in advance of the requested visit. b. Facilities Project Coordinator will confirm within 1 days of request. 3) Contractors and subcontractors shall not reach out to Department Representatives directly with questions, concerns, or to schedule appointments. 4) Deviation from these scheduling procedures is at the discretion of Facilities Project Coordinator.	I acknowledge
PUBLIC WORKS REQUIREMENTS		
A.	The work under this contract is classified as routine maintenance under state law.	I acknowledge and agree
1.	A payment/performance bond is NOT required	I acknowledge and agree

2.	Statutory retainage is NOT required	I acknowledge and agree
B.	Prevailing Wage	Yes
1.	The State prevailing rate of wages to be paid to all workmen, laborers or mechanics employed in the performance of any part of this Contract shall be in accordance with the provisions of Chapter 39.12 of the Revised Code of Washington (RCW) and the rules and regulations of the Washington State Department of Labor and Industries (L & I).	I acknowledge and agree
2.	The State of Washington prevailing wage rates applicable for this public works project, which is located in Spokane County, may be found at the following website address of the Department of Labor and Industries: <a href="https://fortress.wa.gov/lni/wagelookup/prvWagelookup.aspx">https://fortress.wa.gov/lni/wagelookup/prvWagelookup.aspx</a> . Prevailing wages for all work performed pursuant to each work order must be the prevailing wage rates in effect at the beginning date for each contract year. On call contracts must have prevailing wage rates updated annually. Intents and affidavits for prevailing wages paid must be submitted annually for all work completed within the previous twelve-month period of the unit priced contract. (RCW 35.22.620) Upon the anniversary date of the contract, labor rates may be adjusted according to the revised prevailing wages adopted by the Department of Labor and Industries at that time. In order to calculate the change in prevailing wages due to the Contractor, the Contractor shall provide to the City of Spokane a breakdown of the fully loaded labor rates for each classification of labor including hourly wage rates, fringe benefits, overhead and profit. The City of Spokane shall not pay for any price escalation for overhead, profit, equipment, material, or any other costs except for changes in the prevailing wages. The revised prevailing wages shall be effective for any Work issued after the anniversary date of the contract. The basis of modified prevailing wage rates applicable for the contract shall be calculated and issued in writing by the City of Spokane, but such changes shall not be included in a change order. To the extent that the contract sum changes, a change order will be issued as appropriate.	I acknowledge and agree
C.	Apprenticeship	Yes
1.	If apprentices are to be used, they must be registered with the State Apprenticeship Council; otherwise, they are to be paid State prevailing journeyman wages.	I acknowledge and agree
D.	Statement of Intent	Yes

1.	The Contractor and subcontractors will submit a "Statement of Intent to Pay Prevailing Wages" certified by the industrial statistician of the Department of Labor and Industries, prior to any work or payments. The "Statement of Intent to Pay Prevailing Wages" shall include: (1) the Contractor's registration number; and (2) the prevailing wages under RCW 39.12.020 and the number of workers in each classification. Prior to payment of funds held under RCW 39.12.040, the Contractor and subcontractors must submit an "Affidavit of Wages Paid" certified by the industrial statistician annually for all work completed within the previous twelve-month period of the unit priced contract (RCW 35.22.620).	I acknowledge and agree
E.	Filing Fees	Yes
1.	The fee for the approval of 1) "Statements of Intent to Pay Prevailing Wages" and 2) "Affidavits of Wages Paid" is forty dollars (\$40) for each form. The Contractor is responsible for payment of these fees and shall make all applications directly to L & I.	I acknowledge and agree
F.	Department of Labor and Industries' Public Works and Prevailing Wage Training	Yes
1.	As of July 1, 2019 contractors must have fulfilled the Department of Labor and Industries' Public Works and Prevailing Wage Training Requirement before bidding and/or performing work on public works projects under RCW 39.04.350 and RCW 39.06.020	I acknowledge and agree
EXCEPTIONS	If you marked "I do not acknowledge and agree" on any of the areas above, explain here what you are taking exception to.	n/a
GENERAL CONDITIONS		
#1	Contractor acknowledges that they have read and understand the General Conditions Document in the "Documents" tab.	I acknowledge and agree
EXCEPTIONS	If you marked "I do not acknowledge and agree" above - explain here what you are taking exception to.	n/a
TECHNICAL REQUIREMENTS		
Performance	Unless otherwise stated, the Contractor will be responsible for the furnishing of all labor, supervision, materials, tools, construction equipment, transportation, and other items of work and costs necessary for the proper performance and completion of the described Work. The apparent silence or omission as to any detail of any Work to be done or materials to be furnished and required for the proper performance of the Work, shall be regarded as meaning that the best general practice is to prevail, and that material and workmanship of the best quality are to be used, and interpretation of the scope of work shall be made upon this basis.	I acknowledge and agree

Scope of Work	The City of Spokane currently owns and/or is responsible for approximately 400,000 square yards of asphalt surfaced paved parking lots throughout the community and desires to complete maintenance and repair work on a variety of these assets in 2024. These parking areas service libraries, fire stations, parks, police precincts, maintenance yards, etc. It is the intent of the request for bids to solicit bids for the maintenance and repair of the asphalt parking lot surfaces, the repair or replacement of incidental concrete driveway aprons or slabs, and the reapplication of parking lot striping and handicapped striping as necessary to meet all applicable ADA standards.	I acknowledge and agree
Scope of Work	The City of Spokane recognizes that each parking lot is in a different beginning condition. Some lots are essentially like new (having been recently constructed) and others are in need of significant work (likely requiring removal and replacement of failed asphalt). A third category of parking lots are in need of minor repairs or preventative maintenance. For the purposes of this request for bids, the City of Spokane anticipates completing approximately the following amount of work during the 2024-paving season:	I acknowledge and agree; I do not acknowledge and do not agree
1.	20,000 linear feet of small crack clean, prepare & Seal (less than 1"wide)	I acknowledge and agree; I do not acknowledge and I do not agree
2.	20,000 linear feet of Large crack clean, prepare, seal (greater than 1" wide)	I acknowledge and agree; I do not acknowledge and I do not agree
3.	20,000 linear feet of Major crack clean, prepare, Mastic reinforce (Greater than 2" wide)	I acknowledge and agree; I do not acknowledge and I do not agree
4.	45,000 square yards of surface preparation & fog seal.	I acknowledge and agree; I do not acknowledge and I do not agree
5.	45,000 square yards of surface preparation & slurry seal.	I acknowledge and agree; I do not acknowledge and I do not agree
6.	2,500 square yards of surface preparation & chip seal.	I acknowledge and I agree
7.	2,500 square yards of surface preparation & "skin patch".	I acknowledge and agree; I do not acknowledge and I do not agree
8.	1,000 square yards of Small asphalt cut, digout and replace (individually less than 1 square yard)	I acknowledge and agree; I do not acknowledge and I do not agree
9.	1,000 square yards of 1" grind and overlay	I acknowledge and agree; I do not acknowledge and I do not agree

10.	500 square yards of cast in place concrete removal and replacement (4" or 6")	I acknowledge and agree; I do not acknowledge and I do not agree
11.	20,000 linear feet of parking lot striping- standard stall striping	I acknowledge and agree; I do not acknowledge and I do not agree
12.	15,000 linear feet of Parking Lot Striping - Thermalplastic striping	I acknowledge and I agree
13.	45 ea Handicapped Stall Striping	I acknowledge and agree; I do not acknowledge and I do not agree
14.	45 ea Handicapped Stall Striping - Thermalplastic Stall Striping	I acknowledge and agree; I do not acknowledge and I do not agree
Scope of Work	The City of Spokane anticipates utilizing individual task assignments for each parking lot under an overarching "Not to Exceed" master Contract resulting from this Request for Bids. The needs, requirements, desires, and working days for each parking lot will be evaluated and established jointly with City staff and the awarded Contractor. A task assignment for any work shall be prepared utilizing bid items and bid costs established under this Request for Bids. Work shall not be completed without a finalized task assignment signed by the City of Spokane Project Manager. Due to the highly public nature and function of City of Spokane parking lots, liquidated damages will be assessed per task assignment for failure to meet approved working days per task assignment.	I acknowledge and agree; I do not acknowledge and I do not agree
Scope of Work	All Work shall be completed per applicable City of Spokane or referenced WSDOT requirements defining standards and specifications for concrete and asphalt work including products and materials, work methods, final results, and work conditions. As part of this request, Bidders shall submit materials specification sheets for each product or material proposed to be used in the completion of work resulting from this Informal Public Works Quote for review and approval by City staff.	I acknowledge and I agree
Scope of Work	Upload materials specification sheets for each product or material proposed to be used in the completion of work resulting from this Informal Public Works Quote for review and approval by City staff. If you have more than one document to upload, combine them into one document as only one document can be uploaded here.	IPWQ #6104-24 Material Data Sheets.pdf
Scope of Work	Strong customer service and communication by telephone, email, or some combination thereof.	I acknowledge and agree
Scope of Work	Completion of work, whenever possible, in the most timely and cost efficient manner for the citizens of Spokane. If projects across multiple departments may be combined to achieve reductions in timeline and/or price, the Contractor shall make every reasonable effort to do so.	I acknowledge and agree



Scope of Work	The Contractor shall be responsible for obtaining at its expense any related or necessary permits required by regulatory agencies.	I acknowledge and agree
Scope of Work	Under no circumstances, will the total dollar value of work exceed \$300,000 for the 2024 paving season.	I acknowledge and agree; I do not acknowledge and I do not agree
Scope of Work	The winning Contractor shall receive a unit priced contract and, upon complete and accepted performance by the Contractor, the City shall issue payment in the applicable amount set forth on the Pricing Tab for the actual repair performed.	I acknowledge
Service Completion Timeline	The Bidder agrees to start the work under this Contract within ten (10) days of the local asphalt plants opening for the 2024 paving season and to substantially complete the specified work prior to the closing date of the local asphalt plants for the 2024 paving season.	I acknowledge and I agree; I do not acknowledge and I do not agree.
Professionalism	Successful vendor will fulfill contract in a responsible, professional manner at all times. Representatives shall dress appropriately and use acceptable health and safety practices.	I acknowledge and agree
<b>BID</b>		
Quantities	Quantities listed on the Pricing Form are estimates only for the purposes of determining low responsive bid. Payment will be made only for task orders requested and completed satisfactorily.	I acknowledge and I agree
Addenda	Indicate how many Addenda the Contractor acknowledges receipt of and agrees that its requirements have been included in this Bid.	1 if you count the clarification questions.
Withdrawal of Bid	The Contractor agrees that its Bid will NOT be withdrawn for a minimum of sixty (60) calendar days after the stated submittal date.	I acknowledge and agree
Subcontractors	Download and complete the Subcontractor List in the "Documents" tab and upload it.	IPWQ #6104-24 Subcontractor List under \$1M.pdf
<b>CONTRACTOR RESPONSIBILITY</b>		
#1	Provide Washington State Contractor's Registration No.	ARROWCA771CN
#2	Provide Contractor's U.B.I. Number	601 619 703
#3	Provide Contractor's Washington Employment Security Department Number	857730 00 8
#4	Provide Contractor's Washington Excise Tax Registration Number	A17473025
#5	Provide Contractor's City of Spokane Business Registration Number	T12011346BUS
<b>BIDDER RESPONSIBILITY CRITERIA (SUPPLEMENTAL)</b>		
1.	A Bidder will be deemed not responsible if:	Yes
A.	the Bidder does not meet the mandatory bidder responsibility criteria in SMC 7.06.500 and RCW 39.04.350(1), as amended; or	I acknowledge and I agree

B.	the Bidder does not meet the supplemental bidder responsibility criteria as shown in the Supplemental Bidder Responsibility Criteria Document in the Documents tab of this project. The Bidder may be required by the City to submit documentation demonstrating compliance with the criteria.	I acknowledge and I agree
	If a potential Bidder believes that the supplemental bidder responsibility criteria will exclude it from bidding, it may request the City to consider modifying the criteria. Any request shall be submitted to the Purchasing Section of the Accounting Department no later than five (5) days before the bid opening. The City shall evaluate any such request, and if a decision is made by the City to modify the criteria, the modification shall be communicated to all Bidders and plan holders via the issuance of an addendum to the bidding documents. Likewise, in the event the City decides not to modify the criteria, it will endeavor to notify the requesting Bidder of its decision.	I acknowledge and I agree
	As evidence that the Bidder meets the supplemental bidder responsibility criteria, the apparent lowest Bidder shall submit to the City within twenty four (24) hours of the notification time the completed supplementary bidder responsibility form with any required documentation. The City reserves the right to request this documentation from other Bidders as well, and to request further documentation as needed to assess the Bidder's responsibility.	I acknowledge and I agree
	Note a minimum requirement of: • Two (2) completed projects of similar size and scope in the last ten (10) years. Evidence shall be submitted using the supplemental bidder responsibility criteria form attached to this Request for Bids.	I acknowledge and I agree
	The basis for evaluation of Bidder compliance with the supplemental criteria shall be any documents or facts obtained by the City (whether from the Bidder or third parties) which any reasonable owner would rely on for determining compliance. Determinations of responsibility or non-responsibility of a Bidder due to the supplemental criteria shall be based on a review of all the supplemental criteria factors as a whole with no single item being determinative.	I acknowledge and I agree

If the City determines the low Bidder does not meet either the mandatory bidder criteria or the supplemental bidder criteria and is therefore not a responsible Bidder, the contracting Agency shall notify the Bidder in writing with reasons for the determination. If the Bidder disagrees with this determination, it will have a minimum of three (3) business days from receiving the determination to submit additional written information to the City. The City will consider any timely submitted additional information received from the Bidder before issuing its subsequent determination. If the Bidder disagrees with the City's subsequent determination it may appeal the determination to the Mayor or designee in writing within two (2) business days of receiving the City's determination. If the final appeal affirms that the Bidder is not responsible, the City will not execute a Contract with any other Bidder until at least two (2) business days after the Bidder determined to be not responsible has received the final determination.

I acknowledge and I agree

CERTIFICATION OF COMPLIANCE WITH WAGE PAYMENT STATUS

#1 The Contractor hereby certifies that, within the three-year period immediately preceding the bid solicitation date for this Project, the contractor is not a "willful" violator, as defined in RCW 49.48.082, of any provision of chapters 49.46, 49.48, or 49.52 RCW, as determined by a final and binding citation and notice of assessment issued by the Department of Labor and Industries or through a civil judgment entered by a court of limited or general jurisdiction. I certify (or declare) under penalty of perjury under the laws of the State of Washington that the foregoing is true and correct.

I acknowledge

**Pricing Responses**

Group	Reference Number	Description	Type	Unit Of Measure	Quantity	Unit Price	Ext Base Price	Comment
BID								
	1.	Small Crack Clean, Prepare, Seal (less than 1" in width)	Base	L. Ft.	20,000.00	\$1.35	\$27,000.00	
	2.	Large Crack Clean, Prepare, Seal (Greater than 1" in width)	Base	L. Ft.	20,000.00	\$1.75	\$35,000.00	
	3.	Major Crack Clean, Prepare, Mastic Reinforce (Greater than 2")	Base	L. Ft.	20,000.00	\$13.50	\$270,000.00	
	4.	Surface Preparation and Fog Seal	Base	Sq. Yd	45,000.00	\$3.15	\$141,750.00	

5.	Surface Preparation and Slurry Seal	Base	Sq. Yd	45,000.00	\$8.00	\$360,000.00
6.	Surface Preparation and Chip Seal	Base	Sq. Yd	2,500.00	\$10.90	\$27,250.00
7.	Surface Preparation and Skin Patch	Base	Sq. Yd	2,500.00	\$45.90	\$114,750.00
8.	a. 2" Asphalt over 4" Compacted 5/8" Crushed (Individually less than 1 square yard)	Base	Sq. Yd	500.00	\$121.50	\$60,750.00
8.	b. 3" Asphalt over 6" Compacted 5/8" Crushed (Individually less than 1 square yard)	Base	Sq. Yd	500.00	\$135.00	\$67,500.00
9.	1" Asphalt Grind and Overlay	Base	Sq. Yd	1,000.00	\$44.15	\$44,150.00
10.	a. 4" Concrete over 6" Compacted 5/8" Crushed for Slab, Sidewalk or Driveway Apron	Base	Sq. Yd	250.00	\$152.45	\$38,112.50
10.	b. 6" Concrete over 6" Compacted 5/8" Crushed for Slap, Sidewalk or Driveway Apron	Base	Sq. Yd	250.00	\$173.65	\$43,412.50
11.	a. Standard Stall Striping	Base	L. Ft.	20,000.00	\$1.85	\$37,000.00
11.	b. Thermoplastic Striping	Base	L. Ft.	15,000.00	\$4.85	\$72,750.00
12.	a. Handicapped Stall Striping	Base	Per Each	45.00	\$125.00	\$5,625.00
12.	b. Thermoplastic Stall Striping	Base	Per Each	45.00	\$562.50	\$25,312.50
<b>Total Base Bid</b>		<b>\$1,370,362.50</b>				

**SUBCONTRACTOR LIST**

**PROJECT NAME:** IPWQ #6104-24 - 2024 Off-Street Parking Lot Repair & Maintenance

**IMPORTANT: REFER TO SECTION 5.2.1 OF THE SUPPLEMENTAL CONDITIONS FOR INSTRUCTIONS ON COMPLETING THE SUBCONTRACTOR LIST** *(use additional pages if necessary):*

**CONTRACTOR/SUPPLIER** Road Products LLC

TYPE OF WORK/BID ITEM Thermoplastic Striping

AMOUNT TBD

CONTRACTOR'S REGISTRATION NO. ROADPPI772CF

**CONTRACTOR/SUPPLIER** Bright Line Pavement Markings LLC

TYPE OF WORK/BID ITEM Standard Striping

AMOUNT TBD

CONTRACTOR'S REGISTRATION NO. BRIGHLP764MZ

**CONTRACTOR/SUPPLIER** WM Winkler Company

TYPE OF WORK/BID ITEM Concrete Work

AMOUNT TBD

CONTRACTOR'S REGISTRATION NO. WMWINC\*935LA

**CONTRACTOR/SUPPLIER** \_\_\_\_\_

TYPE OF WORK/BID ITEM \_\_\_\_\_

AMOUNT \_\_\_\_\_

CONTRACTOR'S REGISTRATION NO. \_\_\_\_\_

\_\_\_\_\_ **NO SUBCONTRACTORS WILL BE USED ON THIS PROJECT**

THIS PAGE IS NOT REQUIRED TO BE INCLUDED WITH BID SUBMITTAL. PAGE MUST BE SUBMITTED WITHIN 24 HOURS UPON REQUEST BY CITY AFTER BID SUBMITTAL.



## City of Spokane, Washington Supplemental Bidder Responsibility Criteria

After bid opening and prior to award, the apparent low Bidder shall complete, sign and submit this form with attachments to the City (See instructions at the end of this form). The form shall be submitted within twenty four (24) hours after the notification, unless a different time and date is required by the specifications or otherwise mutually agreed upon.

Project Name: 2024 CITY OF SPOKANE OFF-STREET PARKING LOT REPAIR AND MAINTENANCE

Project #: IPWQ #6104-24

### Part A: General Company Information

Company Name: **Arrow Concrete & Asphalt Specialties, LLC.**

Address: **9915 E Trent Avenue, Spokane Valley, WA 99206**

Contact Name and Title: **Jeff Hohenthal, Project Manager**

Contact Phone: **509-922-7847**

Contact E-mail: **jeffh@asphaltsupply.net**

Years in business as a Prime Contractor: **29+ years** Years in business as a sub-Contractor: **29+ years**

Years in business under present Name: **29+ years**

List any former company names under which the company, its owners, and/or its principals has operated in the past five (5) years: **Arrow Concrete & Asphalt Specialties, Inc.**

Explain reason for name change(s) in the past five (5) years: **Corporate Structure Change**

### Part B: Work Experience

If the request for bids has project specific criteria, including work experience, list at least the requested number of construction projects completed within the required time frame on the attached Project Experience form which are similar in type, size and scope of work required for this project.

**Minimum number of completed construction projects required for IPWQ 5864-23 project is:**

- **A minimum of two (2) projects in the last ten (10) years consisting of projects similar in size and scope.**

### Part C: Performance Evaluation

Under past or present names does the Bidder have a history of receiving "deficient" or "inadequate" evaluations on two (2) or more Contracts from the City or other municipalities or another governmental agency on a public works project within the last five (5) years?

Yes       No

If "Yes" attach a separate, signed / dated statement listing the projects and an explanation.

### Part D: Record of Debarment / Disqualification

Has the Bidder (including the primary Contractor, any firm with which any of the primary Contractor's owners, officers, or partners was associated) been debarred, disqualified, removed or has been otherwise prevented from bidding on, or completing any governmental agency or public works projects, including debarment by the federal, state or other municipal government during the last five (5) years?

Yes       No

If "Yes", attach a separate signed / dated statement listing any debarments, disqualifications, removal, etc. from any governmental public works project and the basis for the action.

**Part E: Safety**

In the last five (5) years, has the Bidder received willful or repeat violations of safety or health regulations by the OSHA or other agencies responsible for safety oversight?

Yes       No

If "Yes," attach a separate signed /dated statement describing each willful or repeat violation, including information about the dates and nature of the violations, the project on which the citation(s) was or were issued, the amount of penalty paid, if any. If the citation was appealed and a decision has been issued, state the case number and the date of the decision.

**Part F: Environmental**

In the last five (5) years, has the Bidder received serious citations from government environmental enforcement agencies on projects for which the Bidder was the Contractor?

Yes       No

If "Yes," attach a separate signed / dated statement describing each serious citation, including information about the dates of the citations, the nature of the violation, the project on which the citation(s) was or were issued, the amount of penalty paid, if any. If the citation was appealed and a decision has been issued, state the case number and the date of the decision.

**Part G. Utilization Requirements**

In the last five (5) years, has it been determined by a government agency that the Bidder did not comply with disadvantaged business enterprises, apprenticeship or other similar utilization requirements on public works projects?

Yes       No

If "Yes", attach a separate signed / dated statement listing the violations or failures to meet utilization requirements along with a detailed explanation of the extenuating circumstances surrounding the violation and/or failure.

**Part H: Discrimination**

Has the Bidder or any of its owners, officers or partners been found guilty of violating or failing to comply with discrimination laws in Contracting, employment or provision of public services?

Yes       No

If "Yes", attach a separate signed / dated statement identifying the type of violation, who was involved, the name of the public agency, year of the investigation, the resolution in court or administrative process, and the grounds for the findings.

**Part I. Prevailing Wage**

In the last five (5) years, has the Bidder received prevailing wage violations as determined by the applicable state or federal government agency monitoring prevailing and/or Davis Bacon wage compliance?

Yes       No

If "Yes," attach a separate signed/dated statement listing the prevailing wage violations, along with an explanation of each violation and how it was resolved. The City shall evaluate these explanations and the resolution of each violation to determine whether the violations demonstrate a pattern of failure to pay prevailing wages to workers unless there are extenuating circumstances acceptable to the City.

<b>Part J: Public Bidding Crime (Criminal Convictions)</b>
Has the Bidder been convicted of a crime involving bidding on a public works Contract within the last five (5) years?
<input type="checkbox"/> Yes <input checked="" type="checkbox"/> No
If "Yes", attach a separate signed / dated statement listing the dates of conviction(s), the offense(s) convicted of, the punishment, and a brief statement of the facts underlying the conviction(s)
<b>Part K. Claims Against Retainage and Bonds</b>
Does the Bidder have a record of multiple claims filed against the retainage or payment bonds for public works projects during the previous three (3) years?
<input type="checkbox"/> Yes <input checked="" type="checkbox"/> No
If "Yes", attach a separate signed / dated statement listing the claims filed against the retainage and/or payment bond for any completed public works projects and include for each project a written explanation of the circumstances surrounding the claim and the ultimate resolution of the claim. The City shall evaluate the statement to determine if it demonstrates a lack of effective management by the Bidder of making timely and appropriate payments, unless there are extenuating circumstances acceptable to the City in its sole discretion.
<b>Part L. Termination for Cause</b>
Has the Bidder had any public works Contract terminated for cause by any government agency during the previous five (5) years?
<input type="checkbox"/> Yes <input checked="" type="checkbox"/> No
If "Yes", attach a separate signed / dated statement listing each Contract terminated, the government agency terminating the Contract and the circumstances involving the termination for cause. The City will determine if there are extenuating circumstances acceptable to the City in its sole discretion.
<b>Part M: Litigation</b>
Has the Bidder been involved in lawsuits (or arbitrations for those instances where arbitration is completed in lieu of a lawsuit) with judgments entered against the Bidder for failure to meet terms on Contracts in the previous five (5) years?
<input type="checkbox"/> Yes <input checked="" type="checkbox"/> No
If "Yes", attach a list of lawsuits and/or arbitrations with judgments / arbitration awards entered against the Bidder along with a written explanation of the circumstances surrounding each lawsuit and/or arbitration. The City will evaluate the explanations to determine whether the lawsuits and/or arbitrations demonstrate a pattern of failing to meeting terms of conditions of Contracts, unless there are extenuating circumstances acceptable to the City in its sole discretion.
<b>Part N: Delinquent State Taxes</b>
Does the Bidder owe delinquent taxes to the Washington State Department of Revenue without a payment plan approved by the Department before the date of Contract award?
<input type="checkbox"/> Yes <input checked="" type="checkbox"/> No
If "Yes", attach a separate signed / dated statement describing the circumstances and stating that the Bidder is not on the Washington State Department of Revenue's "Delinquent Taxpayer List".



**Part O: Subcontractor Responsibility**

Does the Bidder's standard subcontract form include the subcontractor language required by RCW 39.06.020? Does the Bidder have an established procedure which it uses to validate the responsibility of each of its subcontractors? Does the subcontract form require that each of the Bidder's subcontractors have and document a similar procedure for sub-tier subcontractors?

Yes       No

If "Yes" or "No", provide a copy of its standard subcontract form and a copy of the procedures used to validate the responsibility of subcontractors.

**Signature**

The undersigned certifies and affirms that the bidder will comply with and notify its principles and subcontractors of the provisions of the Spokane Fair Elections Code, Chapter 01.07, SMC which is viewable at [spokanecity.org](http://spokanecity.org).

The undersigned certifies that the information and data contained herein is correct and complete. Failure to disclose information or submitting false or misleading information may result in rejection of my bid, revocation of award, Contract termination, or may impact my firm's ability to bid on future projects by the City of Spokane.

**Signature of Authorized Representative**

**Date**



April 10, 2024

**Printed Name of Authorized Representative**

**Title**

Kecia M. Washburn

Chief Financial Officer

## Instructions for the Supplemental Bidder Responsibility Form

<p>After bid opening and prior to award, the apparent low Bidder shall complete, sign and submit this form with attached documentation to the City of Spokane Purchasing Section by one of the methods listed below within twenty four (24) hours of notification.</p>	
<p>The City's evaluation may include further investigations to establish the responsibility, qualifications, financial resources and experience of a Bidder to complete the work of this Contract. The City may contact previous owners or others to validate the information provided by the Bidder. The City will assess the information provided and other information gathered in determining whether a Bidder is responsible. List all information you feel is relevant to the City making an informed decision. The City reserves the right to request additional information from the Bidder.</p>	
<p>For criteria with check boxes, the Bidder will check either "Yes" or "No. " For each "Yes" answer on the form, the Bidder shall provide a signed and dated statement providing the project information requested and explaining the extenuating circumstances.</p>	
<p><b>Form Submittal:</b></p>	
<p>Submit this form to Purchasing Section of the City of Spokane as follows within twenty four (24) hours after the time of notification (unless the specifications provide a different time or date)</p>	
<p><b>Email</b> <b>With the Email Subject line:</b></p>	<p><a href="mailto:tprince@spokanecity.org">tprince@spokanecity.org</a> Supplemental Bidder Form for: 2024 CITY OF SPOKANE OFF-STREET PARKING LOT REPAIR AND MAINTENANCE</p>

## Attachment to Supplemental Bidder Responsibility Criteria Work Experience Form

<p>Please complete one form per project and include the minimum number of projects (and forms) as requested. <b>Minimum number of completed construction projects required for: IPWQ 6104-24 - 2023 City of Spokane Off-Street Parking Lot Repair and Maintenance project is:</b></p> <ul style="list-style-type: none"> <li>• <b>A minimum of two (2) projects in the last ten (10) years consisting of projects similar in size and scope.</b></li> </ul> <p>You may include any additional work experience you deem relevant in determining Bidder responsibility. Please be sure to provide a thorough description of the work in order to demonstrate how your firm meets any required experience detailed in the specifications. You may attach additional documentation if needed.</p>			
<b>PROJECT DETAIL</b>			
Bidder's Company Name Arrow Concrete & Asphalt Specialties LLC.		Bidders Contact Name & Phone Number Jeff Hohenthal – 509-922-7847	
Project Name 2022 Off Street Parking & 2023 Off Street Parking		Project Contract Number IPWQ #5586-22 IPWQ #5864-23	
Project Owner City of Spokane		Project Location Spokane, WA (Multiple Locations)	
Project Owner Contact Name & Title David Steele		Owner's Telephone Number 509-625-6064	
Notice to Proceed Date May 1, 2022 May 1, 2023	Final Completion Date October 1, 2022 October 1, 2023	Awarded Contract Value NTE \$200,000.00 NTE \$240,000.00	Final Contract Price \$164,193.20 \$230,530.97
Prime Contractor Name (If Not Bidder) n/a		Contractor Contact Name & Phone Number (If Not Bidder) n/a	
<p><b>Brief Project Description</b> Asphalt cracksealing, sealcoating, chipsealing, slurry sealing, skin patching, asphalt repair, and concrete work.</p>			
<p><b>Brief Summary of Technical Work Completed By Bidder, Including Any Relevant Details To Demonstrate Similar Experience And Any Required Experience Detailed In the Specifications</b> Assess pavement maintenance needs, prep surface as needed and apply sealcoat, chipseal, fogseal as required. Repair deteriorated areas as needed in both asphalt and concrete.</p>			

## Attachment to Supplemental Bidder Responsibility Criteria Work Experience Form

<p>Please complete one form per project and include the minimum number of projects (and forms) as requested. <b>Minimum number of completed construction projects required for: IPWQ 6104-24 - 2024 City of Spokane Off-Street Parking Lot Repair and Maintenance project is:</b></p> <ul style="list-style-type: none"> <li>• <b>A minimum of two (2) projects in the last ten (10) years consisting of projects similar in size and scope.</b></li> </ul> <p>You may include any additional work experience you deem relevant in determining Bidder responsibility. Please be sure to provide a thorough description of the work in order to demonstrate how your firm meets any required experience detailed in the specifications. You may attach additional documentation if needed.</p>			
<b>PROJECT DETAIL</b>			
Bidder's Company Name Arrow Concrete & Asphalt Specialties LLC.		Bidders Contact Name & Phone Number Jeff Hohenthal – 509-922-7847	
Project Name STCU – Wandermere		Project Contract Number n/a	
Project Owner Spokane Teacher's Credit Union (STCU)		Project Location 207 E Hastings Road Spokane, WA 99218	
Project Owner Contact Name & Title Eric Boydston		Owner's Telephone Number 509-209-0747	
Notice to Proceed Date September 1, 2022	Final Completion Date September 30, 2022	Awarded Contract Value \$186,394.51	Final Contract Price \$202,466.35
Prime Contractor Name (If Not Bidder) n/a		Contractor Contact Name & Phone Number (If Not Bidder) n/a	
<p><b>Brief Project Description</b> Re-paving parking lot then striping parking lot, adding wheel blocks and signage as needed.</p>			
<p><b>Brief Summary of Technical Work Completed By Bidder, Including Any Relevant Details To Demonstrate Similar Experience And Any Required Experience Detailed In the Specifications</b> Assess pavement maintenance needs, prep surface as needed pave with HMA. Layout new parking lot parking configuration to maximize usage.</p>			

# **Recommended Performance Guideline For Emulsified Asphalt Slurry Seal A105 (Revised February 2010)**



## **NOTICE**

It is not intended or recommended that this guideline be used as a verbatim specification. It should be used as an outline, helping user agencies establish their particular project specification. Users should understand that almost all geographical areas vary as to the availability of materials. An effort should be made to determine what materials are reasonably available, keeping in mind system compatibility and specific job requirements. Contact ISSA for answers to questions and for a list of ISSA member contractors and companies.

**International Slurry Surfacing Association  
#3 Church Circle, PMB 250  
Annapolis, MD 21401  
(410) 267-0023  
[www.slurry.org](http://www.slurry.org)**

# RECOMMENDED PERFORMANCE GUIDELINE FOR EMULSIFIED ASPHALT SLURRY SEAL

## 1. SCOPE

The intent of this guideline is to aid in the design, testing, quality control, measurement and payment procedures for the application of Emulsified Asphalt Slurry Seal Surfacing.

## 2. DESCRIPTION

Slurry seal shall consist of a mixture of an emulsified asphalt, mineral aggregate, water, and additives, proportioned, mixed and uniformly spread over a properly prepared surface as directed by the Buyer's Authorized Representative (B.A.R.). The slurry seal shall be applied as a homogeneous mat, adhere firmly to the prepared surface, and have a skid-resistant texture throughout its service life.

## 3. SPECIFICATIONS

It is not normally required to run all tests on every project. A compilation of results from the listed tests should be indicative of system performance. Failure to meet specification for an individual test does not necessarily disqualify the system. If, for example, the system to be used on the project has a record of good performance, individual requirements for testing may be waived. Agency and testing methods are listed in the appendix (see Appendix A) and form a part of this guideline.

## 4. MATERIALS

### 4.1 EMULSIFIED ASPHALT

The emulsified asphalt, and emulsified asphalt residue, shall meet the requirements of AASHTO M 140 or ASTM D 977 for SS-1 or SS-1h. For CSS-1, CSS-1h, or CQS-1h, it shall meet the requirements of AASHTO M 208 or ASTM D 2397.

Each load of emulsified asphalt shall be accompanied with a Certificate of Analysis/Compliance to indicate that the emulsion meets the specifications.

### 4.2 AGGREGATE

#### 4.2.1 GENERAL

The mineral aggregate used shall be the type specified for the particular application requirements of the slurry seal. The aggregate shall be crushed stone such as granite, slag, limestone, chat, or other high-quality aggregate, or combination thereof. To assure the material is 100 percent crushed, the parent aggregate will be larger than the largest stone in the gradation to be used.

#### 4.2.2 QUALITY TESTS

The aggregate should meet agency specified polishing values and these minimum requirements:

TEST	TEST METHOD		SPECIFICATION
	AASHTO	ASTM	
Sand Equivalent Value of Soils and Fine Aggregate	T 176	D 2419	45 Minimum
Soundness of Aggregates by Use of Sodium Sulfate or Magnesium Sulfate	T 104	C 88	15% Maximum w/Na <sub>2</sub> SO <sub>4</sub> 25% Maximum w/MgSO <sub>4</sub>
Resistance to Degradation of Small-Size Coarse Aggregate by Abrasion and Impact in the Los Angeles Machine <sup>1</sup>	T 96	C 131	35% Maximum

<sup>1</sup>The abrasion test is run on the parent aggregate.

#### 4.2.3 GRADATION

When tested in accordance with AASHTO T 27 (ASTM C 136) and AASHTO T 11 (ASTM C 117), the mix design aggregate gradation shall be within one of the following bands (or one recognized by the local paving authority):

SIEVE SIZE	TYPE I PERCENT PASSING	TYPE II PERCENT PASSING	TYPE III PERCENT PASSING	STOCKPILE TOLERANCE FROM THE MIX DESIGN GRADATION
<b>3/8 (9.5 mm)</b>	100	100	100	
<b># 4 (4.75 mm)</b>	100	90 - 100	70 - 90	± 5%
<b># 8 (2.36 mm)</b>	90 - 100	65 - 90	45 - 70	± 5%
<b># 16 (1.18 mm)</b>	65 - 90	45 - 70	28 - 50	± 5%
<b># 30 (600 um)</b>	40 - 65	30 - 50	19 - 34	± 5%
<b># 50 (330 um)</b>	25 - 42	18 - 30	12 - 25	± 4%
<b>#100 (150 um)</b>	15 - 30	10 - 21	7 - 18	± 3%
<b>#200 (75 um)</b>	10 - 20	5 - 15	5 - 15	± 2%

The gradation of the aggregate stockpile shall not vary by more than the stockpile tolerance from the mix design gradation (indicated in the table above) while also remaining within the specification gradation band. The percentage of aggregate passing any two successive sieves shall not change from one end of the specified range to the other end.

The aggregate will be accepted at the job location or stockpile based on five gradation tests sampled according to AASHTO T 2 (ASTM D 75). If the average of the five tests is within the stockpile tolerance from the mix design gradation, the material will be

accepted. If the average of those test results is out of specification or tolerance, the contractor will be given the choice to either remove the material or blend additional aggregate with the stockpile material to bring it into compliance. Materials used in blending must meet the required aggregate quality test specifications in Section 4.2.2 before blending and must be blended in a manner to produce a consistent gradation. Aggregate blending may require a new mix design.

Screening shall be required at the stockpile if there are any problems created by oversized materials in the mix.

**Type I.** This aggregate gradation is used to fill surface voids, address moderate surface distresses, and provide protection from the elements. The fineness of this mixture provides the ability for some crack penetration.

**Type II.** This aggregate gradation is used to fill surface voids, address more severe surface distresses, seal, and provide a durable wearing surface.

**Type III.** This aggregate gradation provides maximum skid resistance and an improved wearing surface.

#### **4.3 MINERAL FILLER**

Mineral filler may be used to improve mixture consistency and to adjust mixture breaking and curing properties. Portland cement, hydrated lime, limestone dust, fly ash, or other approved filler meeting the requirements of ASTM D 242 shall be used if required by the mix design. Typical use levels are normally 0.0 - 3.0 percent and may be considered part of the aggregate gradation.

#### **4.4 WATER**

The water shall be free of harmful salts and contaminants. If the quality of the water is in question, it should be submitted to the laboratory with the other raw materials for the mix design.

#### **4.5 ADDITIVES**

Additives may be used to accelerate or retard the break/set of the slurry seal. Appropriate additives, and their applicable use range, should be approved by the laboratory as part of the mix design.

### **5. LABORATORY EVALUATION**

#### **5.1 GENERAL**

Before work begins, the contractor shall submit a signed mix design covering the specific materials to be used on the project. This design will be performed by a laboratory which has experience in designing Emulsified Asphalt Slurry Seal Surfacing. After the mix design has been approved, no material substitution will be permitted unless approved by the B.A.R.

ISSA can provide a list of laboratories experienced in slurry seal design.



**5.2 MIX DESIGN**

Compatibility of the aggregate, emulsified asphalt, water, mineral filler and other additives shall be evaluated in the mix design. The mix design shall be completed using materials consistent with those supplied by the contractor for the project. Recommended tests and values are as follows:

TEST	ISSA TB NO.	SPECIFICATION
Mix Time @ 77°F (25°C)	TB 113	Controllable to 180 Seconds Minimum
Slurry Seal Consistency	TB 106	0.79 – 1.18 inches (2.0 – 3.0 cm)
Wet Cohesion @ 30 Minutes Minimum (Set) @ 60 Minutes Minimum (Traffic)	TB 139 (For quick-traffic systems)	12 kg-cm Minimum 20 kg-cm or Near Spin Minimum
Wet Stripping	TB 114	Pass (90% Minimum)
Wet-Track Abrasion Loss One-hour Soak	TB 100	75 g/ft <sup>2</sup> (807 g/m <sup>2</sup> ) Maximum
Excess Asphalt by LWT Sand Adhesion	TB 109 (Critical in heavy-traffic areas)	50 g/ft <sup>2</sup> (538 g/m <sup>2</sup> ) Maximum

The Wet Track Abrasion Test is performed under laboratory conditions as a component of the mix design process. The purpose of this test is to determine the minimum asphalt content required in a slurry seal system. The Wet Track Abrasion Test is not recommended as a field quality control or acceptance test. ISSA TB 136 describes potential causes for inconsistent results of the Wet Track Abrasion Test.

The mixing test is used to predict the time the material can be mixed before it begins to break. It can be a good reference check to verify consistent sources of material. The laboratory should verify that mix and set times are appropriate for the climatic conditions expected during the project.

The laboratory shall also report the quantitative effects of moisture content on the unit weight of the aggregate (bulking effect) according to AASHTO T19 (ASTM C29). The report must clearly show the proportions of aggregate, mineral filler (if used) and emulsified asphalt based on the dry weight of the aggregate.

The percentages of each individual material required shall be shown in the laboratory report. Based on field conditions, adjustments within the specific ranges of the mix design may be required.

The component materials shall be designed within the following limits:

COMPONENT MATERIALS	SUGGESTED LIMITS
Residual Asphalt	Type I: 10 - 16% Type II: 7.5 - 13.5% Type III: 6.5 - 12% (Based on dry weight of aggregate)
Mineral Filler	0.0 - 3.0% (Based on dry weight of aggregate)
Additives	As needed
Water	As required to produce proper mix consistency

### 5.3 MIX TOLERANCES

Tolerances for the slurry seal mixture are as follows:

- a. After the residual asphalt content is determined, a variation  $\pm 1\%$  by weight of dry aggregate will be permitted.
- b. The slurry consistency, as determined according to ISSA TB No. 106, shall not vary more than  $\pm 0.2"$  ( $\pm 0.5$  cm) from the job mix formula after field adjustments.
- c. The rate of application shall not vary more than  $\pm 2$  lb/yd<sup>2</sup> ( $\pm 1.1$  kg/m<sup>2</sup>) when the surface texture does not vary significantly.

## 6. EQUIPMENT

### 6.1 GENERAL

All equipment, tools, and machines used in the application of slurry seal shall be maintained in satisfactory working condition at all times.

### 6.2 MIXING EQUIPMENT

The machine shall be specifically designed and manufactured to apply slurry seal. The material shall be mixed by an automatic-sequenced, self-propelled, slurry seal mixing machine of either truck-mounted or continuous-run design. Continuous-run machines are those that are equipped to self-load materials while continuing to apply slurry seal. Either type machine shall be able to accurately deliver and proportion the mix components through a mixer and to discharge the mixed product on a continuous-flow basis. Sufficient storage capacity for all mix components is required to maintain an adequate supply to the proportioning controls.

The B.A.R. should decide which type of equipment best suits the specific project. In some cases, truck-mounted machines may be more suited, i.e. cul-de-sacs, small narrow roadways, parking lots, etc. On some projects, continuous-run equipment may be chosen due to the continuity of mix and the reduction of start-up joints. Generally, truck-mounted machines or continuous-run machines may be used on similar projects.

If continuous-run equipment is used, the machine shall provide the operator with full control of the forward and reverse speeds during application of the slurry seal. It shall be equipped with a self-loading device and opposite-side driver stations. The self-loading device, opposite-side driver stations, and forward and reverse speed controls shall be of original-equipment-manufacturer design.

### **6.3 PROPORTIONING DEVICES**

Individual volume or weight controls for proportioning mix components shall be provided and properly labeled. These proportioning devices are used in material calibration to determine the material output at any time.

### **6.4 SPREADING EQUIPMENT**

The mixture shall be placed uniformly by means of a spreader box attached to the paver and mechanically equipped, if necessary, to agitate and spread the material evenly throughout the box. With some quick-set systems, mechanical agitation may extend mix time. The slurry seal mixture shall have the proper consistency as it enters the spreader box. Spraying of additional water into the spreader box will not be permitted.

A front seal shall be utilized to ensure no loss of the mixture at the road contact point. The rear seal shall act as final strike-off and shall be adjustable. The spreader box and rear seal shall be designed and operated to provide uniform mix consistency behind the box. The spreader box shall have suitable means to side shift to compensate for variations in the pavement width. A burlap drag or other approved screed may be attached to the rear of the spreader box to provide a highly textured uniform surface. A drag stiffened by hardened slurry is ineffective and should be replaced immediately.

### **6.5 AUXILIARY EQUIPMENT**

Suitable surface preparation equipment, traffic control equipment, hand tools, and other support and safety equipment necessary to perform the work shall be provided by the contractor.

## **7. CALIBRATION**

Each mixing unit to be used in performance of the work shall be calibrated in the presence of the B.A.R. prior to the start of the project. Previous calibration documentation covering the exact materials to be used may be acceptable, provided the calibration was performed during the previous 60 days. The documentation shall include an individual calibration of each material at various settings, which can be related to the machine's metering devices. Any equipment replacement affecting material proportioning requires that the machine be recalibrated. No machine will be allowed to work on the project until the calibration has been accepted. ISSA Inspector's Manual describes a method of machine calibration. ISSA contractors and/or machine manufacturers may also provide methods of machine calibration.

## 8. WEATHER LIMITATIONS

The slurry seal shall not be applied if either the pavement or air temperature is below 50°F (10°C) and falling, but may be applied when both pavement and air temperatures are above 45°F (7°C) and rising. No slurry seal shall be applied when there is the possibility of freezing temperatures at the project location within 24 hours after application. The mixture shall not be applied when weather conditions prolong opening to traffic beyond a reasonable time.

## 9. NOTIFICATION AND TRAFFIC CONTROL

### 9.1 NOTIFICATION

Homeowners and businesses affected by the paving shall be notified at least one day in advance of the surfacing. Should work not occur on the specified day, a new notification will be distributed. The notification shall be posted in written form, stating the time and date that the surfacing will take place. If necessary, signage alerting traffic to the intended project should be posted.

### 9.2 TRAFFIC CONTROL

Traffic control devices shall be in accordance with agency requirements and, if necessary, conform to the requirements of the Manual on Uniform Traffic Control Devices. Opening to traffic does not constitute acceptance of the work.

In areas that are subject to an increased rate of sharp-turning vehicles, additional time may be required for a more complete cure of the slurry seal mat to prevent damage. Tire marks may be evident in these areas after opening but typically diminish over time with rolling traffic.

## 10. SURFACE PREPARATION

### 10.1 GENERAL

Prior to applying the slurry seal, loose material, oil spots, vegetation, and other objectionable material shall be removed. Any standard cleaning method will be acceptable. If water is used, cracks shall be allowed to dry thoroughly before slurry surfacing. Manholes, valve boxes, drop inlets and other service entrances shall be protected from the slurry seal by a suitable method. The B.A.R. shall approve the surface preparation prior to surfacing.

### 10.2 TACK COAT

Normally, tack coat is not required unless the surface to be covered is extremely dry and raveled or is concrete or brick. If required, the emulsified asphalt should be SS, CSS, or the slurry seal emulsion. Consult with the slurry seal emulsion supplier to determine dilution stability. The tack coat may consist of one part emulsified asphalt/three parts water and should be applied with a standard distributor. The distributor shall be capable of applying the dilution evenly at a rate of 0.05-0.15 gal/yd<sup>2</sup> (0.23-0.68 l/m<sup>2</sup>). The tack coat shall be allowed to cure sufficiently before the application of slurry seal. If a tack coat is to be required, it must be noted in the project plans.

### 10.3 CRACKS

It is recommended to treat cracks wider than 0.25" (0.64cm) in the pavement surface with an approved crack sealer prior to application of the slurry seal.

## 11. APPLICATION

### 11.1 GENERAL

If required, it is recommended that a test strip be placed in conditions similar to those expected to be encountered during the project.

The surface may be wetted with water ahead of the spreader box. The rate of application of the water spray shall be adjusted during the day to suit temperature, surface texture, humidity, and dryness of the pavement. Pooling or standing water shall be avoided.

The slurry seal shall be of the desired consistency upon exiting the mixer. A sufficient amount of material shall be carried in all parts of the spreader box at all times so that complete coverage is achieved. Overloading of the spreader shall be avoided.

No lumping, balling, or unmixed aggregate shall be permitted.

Significant streaks, such as those caused by oversized aggregate or broken mix, shall not be left in the finished surface. If excessive streaking occurs, the job will be stopped until the cause of the problem has been corrected. Some situations may require screening the aggregate prior to loading it into the units going from the stockpile area to the jobsite.

### 11.2 RATE OF APPLICATION

The slurry seal mixture shall be of the proper consistency at all times so as to provide the application rate required by the surface condition. The average application rate shall be in accordance with the following table:

AGGREGATE TYPE	LOCATION	SUGGESTED APPLICATION RATE
Type I	Parking Areas Urban and Residential Streets Airport Runways	8 - 12 lb/yd <sup>2</sup> (4.3 - 6.5 kg/m <sup>2</sup> )
Type II	Urban and Residential Streets Airport Runways	10 - 18 lb/yd <sup>2</sup> (5.4 - 9.8 kg/m <sup>2</sup> )
Type III	Primary and Interstate Routes	15 - 22 lb/yd <sup>2</sup> (8.1 - 12.0 kg/m <sup>2</sup> )

Suggested application rates are based upon the weight of dry aggregate in the mixture. Application rates are affected by the unit weight and gradation of the aggregate and the demand of the surface to which the slurry seal is being applied.

### 11.3 JOINTS

No excess buildup, uncovered areas, or unsightly appearance shall be permitted on longitudinal or transverse joints. The contractor shall provide suitable equipment to produce a minimum number of longitudinal joints throughout the project. When possible, a longitudinal joint shall not be placed in a wheel path. Less than full box width passes will be used only as required. If less than full box width passes are used, they shall not be the last pass of any paved area. A maximum of 6" (15.2 cm) shall be allowed for overlap of longitudinal joints.

### 11.4 MIXTURE

The slurry seal shall possess sufficient stability so that premature breaking of the material in the spreader box does not occur. The mixture shall be homogeneous during and following mixing and spreading. It shall be free of excess liquids which create segregation of the aggregate. Spraying of additional water into the spreader box will not be permitted.

### 11.5 HANDWORK

Areas which cannot be accessed by the mixing machine shall be surfaced using hand squeegees to provide complete and uniform coverage. If necessary, the area to be handworked shall be lightly dampened prior to mix placement. Handwork shall exhibit the same finish as that applied by the spreader box and shall be completed prior to final surfacing.

### 11.6 LINES

Care shall be taken to apply straight lines along curbs, shoulders, and intersections. No run-off on these areas will be permitted. Roofing felt or heavy plastic may be used to begin or end a pull cleanly. This also provides for easy removal of excess slurry.

### 11.7 ROLLING

Rolling is usually not necessary for slurry seal on roadways. Airports and parking areas should be rolled by a self-propelled, 10-ton (maximum) pneumatic tire roller equipped with a water spray system. All tires should be inflated per manufacturer's specifications. Rolling shall not start until the slurry has cured sufficiently to avoid damage by the roller. Areas which require rolling shall receive a minimum of two (2) full coverage passes.

### 11.8 CLEAN UP

All utility access areas, gutters and intersections, shall have the slurry seal removed as specified by the B.A.R. The contractor shall remove any debris associated with the performance of the work on a daily basis.

## 12. QUALITY CONTROL

### 12.1 INSPECTION

Inspectors assigned to projects must be familiar with the materials, equipment and application of slurry seal. Local conditions and specific project requirements should be considered when determining the parameters of field inspection.

Proper mix consistency should be one of the major areas of inspector concern. If mixes are too dry, streaking, lumping and roughness will be present in the mat surface. Mixes applied too wet will flow excessively and not hold straight lane lines. Excessive liquids may also cause an asphalt-rich surface with segregation.

## **12.2 MATERIALS**

To account for aggregate bulking, it is the responsibility of the contractor to check stockpile moisture content and to set the machine accordingly. At the B.A.R.'s discretion, material tests may be run on representative samples of the aggregate and emulsion. Tests will be run at the expense of the buyer. The buyer must notify the contractor immediately if any test fails to meet the specifications.

## **12.3 SLURRY SEAL**

If required, representative samples of the slurry seal may be taken directly from the slurry unit(s). Consistency (ISSA TB No. 106) and residual asphalt content (ASTM D2172) tests may be run on the samples. Please note that the consistency test may not be applicable to certain Quick-Set and Quick-Traffic systems because of erratic results due to setting characteristics. If this test is run, it must be performed immediately after the sample is taken. Tests will be run at the expense of the buyer. The buyer must notify the contractor immediately if any test fails to meet specifications.

Data obtained from the proportioning devices on the slurry seal unit may be used to determine individual material quantities and application rate.

## **12.4 NON-COMPLIANCE**

If any two successive tests fail on the stockpile aggregate, the job shall be stopped. If any two successive tests on the mix from the same machine fail, the use of the machine shall be suspended. It will be the responsibility of the contractor, at his expense, to prove to the B.A.R. that the problems have been corrected.

## **13. PAYMENT**

The slurry seal shall be measured and paid for by the unit area or weight of aggregate and the weight of emulsion used on the work completed and accepted by the buyer. If paid by the weight of the aggregate and emulsified asphalt, the contractor shall submit to the B.A.R. certified delivery tickets which show quantities of each material delivered to the job site and used on the project. Payment shall be full compensation for all preparation, mixing and application of materials, and for all labor, equipment, tools, testing, cleaning, and incidentals necessary to complete the job as specified herein.

## APPENDIX A

### AGENCIES

**AASHTO:** American Association of State Highway and Transportation Officials  
**ASTM:** American Society for Testing and Materials  
**ISSA:** International Slurry Surfacing Association

### TEST METHODS

#### EMULSIFIED ASPHALT

AASHTO TEST NO.	ASTM TEST NO.	TEST
M 140	D 977	Standard Specification for Emulsified Asphalt
M 208	D 2397	Specification for Cationic Emulsified Asphalt
T 40	D 140	Sampling Bituminous Materials
T 59	D 244	Test Methods and Practices for Emulsified Asphalts
T 59	D 6997	Distillation of Emulsified Asphalt

#### AGGREGATE AND MINERAL FILLER

AASHTO TEST NO.	ASTM TEST NO.	TEST
T 176	D 2419	Sand Equivalent Value of Soils and Fine Aggregate
T 104	C 88	Soundness of Aggregates by Use of Sodium Sulfate or Magnesium Sulfate
96	C 131	Resistance to Degradation of Small-Size Coarse Aggregate by Abrasion and Impact in the Los Angeles Machine (This test should be performed on the parent rock that is used for crushing the finer gradation Micro Surfacing material.)
T 27	C 136	Sieve Analysis of Fine and Coarse Aggregates
T 11	C 117	Test Method for Materials Finer than 75µm (No. 200) Sieve in Mineral Aggregates by Washing
T 2	D 75	Sampling Aggregates
M 17	D 242	Mineral Filler for Bituminous Paving Mixtures
T 19	C 29	Bulk Density ("Unit Weight") and Voids in Aggregate



**APPENDIX A**

**TEST METHODS (CONTINUED)**

**SLURRY SEAL SYSTEM**

ISSA TEST NO.	Test
TB 100	Test Method for Wet Track Abrasion of Slurry Surfaces
TB 101	Guide for Sampling Slurry Mix for Extraction Test
TB 106	Measurement of Slurry Seal Consistency
TB 109	Test Method for Measurement of Excess Asphalt in Bituminous Mixtures by Use of a Loaded-Wheel Tester
TB 111	Outline Guide Design Procedure for Slurry Seal
TB 112	Method of Estimate Slurry Seal Spread Rates and To Measure Pavement Macrotecture
TB 113	Trial Mix Procedure for Slurry Seal Design
TB 114	Wet Stripping Test for Cured Slurry Seal Mixes
TB 115	Determination of Slurry Seal Compatibility
TB 139	Method of Classified Emulsified Asphalt, Aggregate Mixtures by Modified Cohesion Test Measurement of Set and Cure Characteristics
A105	Design, Testing, and Construction of Slurry Seal

**NOTES:**

ASTM D 3910, Standard Practice for Design, Testing, and Construction of Slurry Seal, is a combined reference of the ISSA Test Bulletins listed above.

ASTM D 2172, Standard Test Methods for Quantitative Extraction of Bitumen From Bituminous Paving Mixtures, is referenced in Section 12.3.





**ISSA A105**  
**Revised February 2010**



**International Slurry Surfacing Association**  
**#3 Church Circle, PMB 250**  
**Annapolis, MD 21401**  
**(410) 267-0023**  
**[www.slurry.org](http://www.slurry.org)**



# LABORATORY SUMMARY

<b>PROJECT NAME:</b>	Source Evaluation	<b>SOURCE:</b>	Upper Duthie Pit (NP-162c)
<b>CLIENT NAME:</b>	Atlas Sand & Gravel	<b>PROJECT NO:</b>	320-025G1
<b>LOCATION:</b>	Lewiston, Idaho	<b>DATE:</b>	2/24/2020

<b>LAB SAMPLE NUMBER:</b>		S320-0030	
<b>SAMPLED BY:</b>		Shawn Turpin, P.E.	
<b>DATE SAMPLED:</b>		1/30/2020	
<b>MATERIAL:</b>		Ripped Basalt	
TEST DESCRIPTION	SPEC	TEST RESULTS	
<b>IDAHO DEGRADATION (IDAHO T15)</b>			
Degradation Loss (%)	≤ 5.0	2.8	
<b>Sieve Analysis (AASHTO T27/T248)</b>			
		BEFORE	AFTER
3/4"		100	100
1/2"		83	84
3/8"		67	67
#4		50	50
#8		28	30
#16		17	19
#30		11	13
#50		8	10
#100		6	8
#200		3.8	6.6
<b>SAND EQUIVALENT (AASHTO T176)</b>			
	≥ 40	94	86
<b>L.A. ABRASION (AASHTO T96)</b>			
Loss (%)	≤ 30	12	
<b>DMSO (WFLH METHOD)</b>			
Weight Loss (%)	≤ 12	1	
<b>SODIUM SULFATE SOUNDNESS (AASHTO T104)</b>			
Coarse Aggregate Loss (%)	≤ 12	1	
Fine Aggregate Loss (%)	≤ 10	6	
<b>ETHYLENE GLYCOL (IDAHO T116)</b>			
Retained (%)	≥ 90	99	
<b>REVIEWED BY</b>		<b>DATE</b>	<b>2/24/2020</b>

This report shall not be reproduced except in full without the permission of ALLWEST

2705 E. Main Street • Lewiston, ID 83501 • (208) 743-5710 • Fax (208) 743-8270

**READ BEFORE USING THIS PRODUCT**

**GENERAL** RoadSaver Low Tack Type 1 is a hot-applied petroleum based product used to fill and seal cracks in asphalt or portland cement concrete pavements in cool to warm climates. RoadSaver Low Tack Type 1 is supplied in solid form which when melted and properly applied forms a high stiffness, adhesive and flexible compound that resists cracking at winter temperatures and is highly resistant to flow or pick-up at extreme summer temperatures. RoadSaver Low Tack Type 1 is used in highway, street, airfield and parking lot pavements and is applied to pavement cracks using either pressure feed melter applicators or pour pots. At application temperature it is a free flowing, self-leveling product. RoadSaver Low Tack Type 1 is specifically formulated to be a stiff, flow resistant, yet flexible product which is suited for use in areas subject to slow moving vehicle traffic where high resistance to pick-up or tracking is required. VOC = 0 g/l.

**USAGE GUIDELINES** RoadSaver Low Tack Type 1 pavement temperature performance limits are 70-28 for crack filling and 76-10 for crack sealing. Usage recommendations are shown in CrafcO pavement temperature grade charts at the right. Refer to CrafcO Product Selection Procedures to determine sealant or filler use and pavement temperature grades.

	Not Recommended
	Performance Limits
	Recommended
	Suited for Use

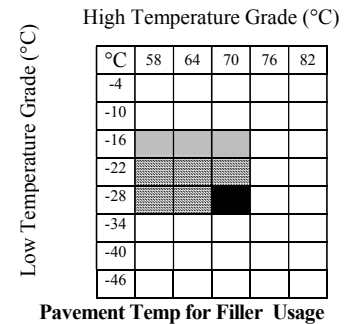
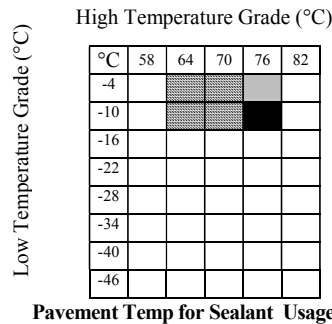

**SPECIFICATION CONFORMANCE** RoadSaver Low Tack Type 1 meets the following requirements of ASTM D6690, Type II, "Joint and Crack Sealants, Hot-applied, for Concrete and Asphalt Pavements", (formerly ASTM D3405), AASHTO M301 and Federal Specification SS-S-1401C):

<b>Test</b>	<b>ASTM D6690, Type II Spec. Limits</b>
Cone Penetration	90 max.
Softening Point	176F (80C) min.
Asphalt Compatibility	Pass
Minimum Application Temperature	380°F (193°C)
Maximum Heating Temperature	400°F (204°C)
Additional limits for RoadSaver Low Tack Type 1 when heated to maximum heating temperature in accordance with ASTM D5167:	
Softening Point (ASTM D36)	205°F (96°C) min.
Cone Penetration (ASTM D5329)	60 max.
Resilience (ASTM D5329)	40% min.
Flexibility (ASTM D3111)	
1/8" (3mm) thick, 1" (25mm) mandrel, 90° bend, 10 sec	Pass at -20°F (-28°C)
1/4" (6.4mm) thick, 1/4" (6.4mm) mandrel, 180° bend, 1 sec	Pass at 14°F (-10°C)
Viscosity (ASTM D4402)	50 poise max at 400°F (204°C)
Bitumen Content (ASTM D4)	60% min.
Tensile Adhesion (ASTM D5329)	500% min.

**INSTALLATION** The unit weight of RoadSaver Low Tack Type 1 is 10.3 lbs. per gallon (1.23 kg/L) at 60F (15.5C). Prior to use, the user must read and follow Installation Instructions for Hot-Applied RoadSaver, Polyflex, Parking Lot and Asphalt Rubber Products to verify proper product selection, heating methods, pavement preparation procedures, application geometry, usage precautions and safety procedures. These instructions are provided with each pallet of sealant.

**PACKAGING** Packaging consists of individual boxes of product which are palletized into shipping units. Boxes contain a non-adherent film which permits easy removal of the sealant. Each pallet contains 72 boxes which are stacked in six layers of 12 boxes per layer. The weight of product in each box does not exceed 40 lbs. (18kg) and pallet weights do not exceed 2,880 lbs. (1310kg). Pallets of product are weighed and product is sold by the net weight of product. Product boxes are manufactured from double wall kraft board producing a minimum bursting test certification of 350 psi (241 N/cm<sup>2</sup>) and using water resistant adhesives. Boxes use tape closure and do not contain any staples. Boxes are labeled with the product name, part number, lot number, specification conformance, application temperatures and safety instructions. Palletized units are protected from the weather using a three mil thick plastic bag, a weather and moisture resistant cap sheet and a minimum of two layers of six month u.v. protected stretch wrap. Pallets are labeled with the product part number, lot number and net weight. Installation Instructions are provided with each pallet in a weather resistant enclosure.

**WARRANTY** CRAFCO, Inc. warrants that CRAFCO products meet applicable ASTM, AASHTO, Federal or State specifications at time of shipment. Techniques used for the preparation of the cracks and joints prior to sealing or filling are beyond our control as are the use and application of the products; therefore, CrafcO shall not be responsible for improperly applied or misused products. Remedies against CrafcO, Inc., as agreed to by CrafcO, are limited to replacing nonconforming product or refund (full or partial) of purchase price from CrafcO, Inc. All claims for breach of this warranty must be made within three (3) months of the date of use or twelve (12) months from the date of delivery by CrafcO, Inc. whichever is earlier. There shall be no other warranties expressed or implied. **For optimum performance, follow CrafcO recommendations for product installation.**

6165 W Detroit St. • Chandler AZ 85226  
 +1 (602) 276-0406 • +1 (800) 528-8242 • FAX +1 (480) 961-0513  
 www.crafco.com

**READ BEFORE USING THIS PRODUCT**

**GENERAL** Mastic One is a hot-applied, pourable, aggregate filled, black color, polymer modified asphalt pavement repair mastic. Mastic One complies with ASTM D8260 Type I. Mastic One is used for sealing, filling and repairing many distresses in both asphalt concrete and portland cement concrete pavements and bridge deck surfaces that are larger than those typically repaired by crack or joint sealing, but smaller than repairs requiring remove and replace patching procedures. Typical uses include sealing, filling and leveling of wide transverse or longitudinal cracks and joints, filling potholes and utility cuts, localized skin patch repairs, repairs prior to surface treatments, and leveling bridge approaches or faulted areas. When properly applied, Mastic One forms a well-bonded, flexible, durable, traffic resistant repair. To use, Mastic One is placed into an appropriate melter (Crafco Patcher units), mixed and heated until application temperature is reached, poured into the prepared repair area and then leveled. Mastic One is formulated to provide neat feathered edge installation. Mastic One is then ready for traffic when it has cooled and solidified. VOC = 0 g/l.

**PROPERTIES** Properties of the binder, aggregate and blended and heated Mastic One according to ASTM D8260 are as follows:

<u>Property</u>	<u>Requirement</u>
<b>POLYMER MODIFIED BINDER</b>	
Cone Penetration, 77°F (25°C) (ASTM D5329)	60 max
Cone Penetration, 122°F (50°C) (ASTM D5329)	120 max
Softening Point, (ASTM D36)	200°F (93°C) min
Flexibility, 1" (25.4 mm), 180°, 10 sec) (ASTM D3111 modified)	Pass at 32°F (0°C)
<b>AGGREGATE</b>	
Abrasion Resistance (ASTM C131)	35% max
<b>BLENDED PRODUCT</b>	
Flexibility, 32°F (0°C) (ASTM D5329)	Pass
Adhesion, 77°F (25°C) (ASTM D5329)	25 PSI (172 KPA) min
Specific Gravity	1.7 -2.0
Minimum Application Temperature	375°F (190°C) *
Maximum Application Temperature	400°F (204°C)

<u>Test</u>	<u>ASTM D8260 Type I Specification Limits</u>
Mastic Resilience (ASTM (8260)	50% minimum
Effects of Rapid Deformation (ASTM D2794) (-7°C)	3 passing specimens no chipping, cracking or separation 8 N-m
Crack Bridging (ASTM C1305 modified) (-7°C)	Pass 3 cycles
Mastic Stability (ASTM D8260) (70°C)	40.0 mm maximum

\*Refer to installation instructions if working on sloped pavements or repairing larger defects

**INSTALLATION** The density of Mastic One is 116 pcf (+/- 3%) and the weight per gallon is 15.5 lbs./gal (1.86 kg/l) at 60°F (15.5°C). Prior to use, the user must read and follow Installation Instructions for Mastic One to verify proper product selection, heating methods, pavement preparation procedures, application geometry, usage precautions and safety procedures. These instructions are available at www.crafco.com and provided with each pallet of Mastic One.

**PACKAGING** Mastic One is supplied in either cardboard boxes, or in meltable, boxless PLEXI-melt packaging. Each package contains premeasured polymer modified binder and aggregate. Both package types are labeled in accordance with OSHA, GHS, and specification requirements; are sold by net weight; are interlock stacked on 48 x 40 in. (122 x102 cm) 4-way pallets; can be stored outside; and are covered with a weather resistant pallet cover and 2 layers of UV protected stretch wrap.

- o **BOX** packaging consists of cardboard boxes containing approximately 40 lb. (18.1 kg) of product with 60 boxes per pallet, weighing approximately 2400 lb. (1088 kg). Boxes contain a quick melting release film for easy removal and are taped closed, without any staples.
- o **PLEXI-melt** packaging consists of 30 lb. (13.6 kg) blocks of product with 70 packages per pallet, weighing 2100 lb. (952 kg). To use, the pallet wrap is removed, and individual blocks are placed in the melter. There are no cardboard boxes or other cardboard components to open, empty, handle, or dispose of. PLEXI-melt packaging quickly melts into the product without affecting specification conformance.



**WARRANTY** CRAFCO, Inc. warrants that CRAFCO products meet applicable ASTM, AASHTO, Federal or State specifications at time of shipment. Techniques used for the preparation of the cracks and joints prior to sealing or filling are beyond our control as are the use and application of the products; therefore, Crafco shall not be responsible for improperly applied or misused products. Remedies against Crafco, Inc., as agreed to by Crafco, are limited to replacing nonconforming product or refund (full or partial) of purchase price from Crafco, Inc. All claims for breach of this warranty must be made within three (3) months of the date of use or twelve (12) months from the date of delivery by Crafco, Inc. whichever is earlier. There shall be no other warranties expressed or implied. **For optimum performance, follow Crafco recommendations for product installation.**

<b>1. Product Identification, Company Identification, Recommended Uses and Use Restrictions</b>	
<b>Product Name</b>	EMULSIFIED ASPHALT, CATIONIC, ALL GRADES
<b>Product Family</b>	Asphalt Mixture
<b>CAS Number</b>	Mixture
<b>Synonyms</b>	Emulsified Asphalt, CRS-1, CRS-1h, CRS-2, CRS-2h, CRS-2L, CRS-2P, CMS-2, CMS-2N, CSS-1h, CQS-1hLM, CQS-1hLM Flex, EADA, Thimaco, Fibermat™, Tack Coat, Tack Coat (diluted 30-50% with water), NTT, Non-Tracking Tack, Cold In-Place Recycling Emulsion, IPR Emulsion
<b>Manufacturer</b>	<b>ROAD PRODUCTS INC.</b>
	12301 E. Empire Ave Spokane Valley WA 99216 509-922-1206
	PO BOX 11072 Spokane Valley WA 99211 Fax 509-922-0156
<b>Technical Contact</b>	Rick Fulwiler Spokane Valley WA 99216 509-922-1206
<b>Emergency Contact</b>	<b>ChemTrec – 24 hour</b> <b>1-800-424-9300</b>
<b>Web MSDS</b>	<a href="http://www.asphaltsupply.net">www.asphaltsupply.net</a>
<b>Recommended Uses</b>	Road Maintenance Operations including Slurry Seal, Microsurfacing, Surface Treatment, HMA Paving, Cold In-Place Recycling
<b>Use Restrictions</b>	Temperatures must be above freezing

<b>2. Hazard Identification</b>	
<b>Physical State</b>	Liquid
<b>Color</b>	Brown to Black
<b>Odor</b>	Mild Petroleum Odor
	Liquid can cause eye and skin irritation Avoid prolonged contact with eyes, skin and clothing Hot product can cause burns Fumes from hot product can cause irritation to eyes, skin and respiratory system



## 2. Hazard Identification, continued

	Harmful to aquatic organisms
	Respiratory Sensitizer
<b>NFPA Rating</b>	Health=1, Fire=1, Reactivity=0 RATING SCALE:
<b>HMIS Rating</b>	Health=1 (Chronic), Fire=1, Reactivity=0 RATING SCALE:

## 3. Composition/Information on Ingredients

Component Name	CAS Number	Concentration, %
Petroleum Asphalt	8052-42-4	38-72
Water	7732-18-5	62-28
Fuel Oil Flux	68334-30-5	0-6
Stoddard Solvent	8052-41-3	0-6
Hydrochloric Acid	7647-01-0	0.1-2.5
SBR Co-Polymer	9003-55-8	0-4.5
Dispersion Polymer Modifier	Mixture	0-5
Fatty Amine Emulsifier	Mixture	0.1-2.5
Hydrogen Sulfide	7783-06-4	0-0.1

CMS-2N: Contains Stoddard Solvent



**SAFETY DATA SHEET**  
**Emulsified Asphalt**  
**Cationic, All Grades**

<b>4. First Aid Measures</b>	
<b>Skin Contact</b>	<p><b>HOT PRODUCT:</b> Immediately flush the area with large amounts of cool water. Do not attempt to remove material from the skin or to remove contaminated clothing. Seek immediate medical attention</p> <p><b>COOL PRODUCT:</b> Wash the skin with plenty of soap and water. Remove contaminated clothing and shoes and place into a container for laundering or disposal – clean contaminated clothing before reuse. If skin is reddened or blistered, seek medical attention.</p>
<b>Eye Contact</b>	<p><b>HOT PRODUCT:</b> Hold the eyelids apart and flush with cool water for at least 15 minutes. <b>SEEK IMMEDIATE MEDICAL ATTENTION.</b> Hot Product may cause thermal burns to eyes</p> <p><b>COOL PRODUCT:</b> Flush with cold water or saline solution. Seek medical attention</p>
<b>Ingestion</b>	<p><b>DO NOT INDUCE VOMITING. SEEK IMMEDIATE MEDICAL ATTENTION</b></p> <p><b>HOT PRODUCT:</b> May cause thermal burns in the mouth, throat and esophagus</p> <p><b>COOL PRODUCT:</b> May cause irritation in the mouth, throat and esophagus</p>
<b>Inhalation</b>	<p>Move the person to fresh air and monitor for respiratory distress</p> <p><b>NOT BREATHING:</b> Begin rescue breathing and <b>SEEK IMMEDIATE MEDICAL ATTENTION.</b></p> <p><b>NOTE:</b> Inhalation exposure of fumes of hot product can produce toxic effects. Treat intoxications as hydrogen sulfide exposures.</p>

<b>5. Fire Fighting Measures</b>	
<b>Extinguishing Media</b>	Dry chemical foam, carbon dioxide or water fog
<b>Hazardous Combustion Products</b>	Carbon dioxide, carbon monoxide, oxides of sulfur and/or nitrogen, unburned hydrocarbons and smoke fumes. At elevated temperatures hydrogen sulfide and other sulfur containing gases may be produced.
<b>Special Properties</b>	Asphalt emulsions normally will not ignite. Asphalt residues will burn if heated. At elevated temperatures asphalt emulsions may separate to form a layer of asphalt and a layer of water. Fire in the vicinity of storage tanks may cause a boiling liquid-expanding vapor explosion (BLEVE).



**SAFETY DATA SHEET**  
**Emulsified Asphalt**  
**Cationic, All Grades**

<b>6. Accidental Release Measures</b>	
<b>Personal Precautions</b>	Wash hands and other exposed skin areas with soap and water before eating, drinking, smoking, using toilet facilities or leaving the work area. Use only cleaning soaps/agents approved for human use – do not use gasoline, kerosene, solvents or harsh abrasives
<b>Personal Protective Equipment (PPE)</b>	<p>GENERAL: Minimum PPE recommended is safety glasses, work gloves and work shoes.</p> <p>EYE: Safety glasses for small spills, Goggles or face shield for large spills. A suitable eyewash station should be located in the vicinity of the work area.</p> <p>HAND: Standard work gloves recommended. Nitrile, neoprene or butyl gloves recommended for repeated or prolonged use.</p> <p>RESPIRATORY: With adequate ventilation a respirator is usually not required. In those cases where exposure exceeds the occupational control limits a NIOSH/MSA approved air purifying particulate respirator suitable for dusts, fumes and mists is recommended. Respirators should be used in accordance with 29 CFR 1910.134.</p>
<b>Small Spills</b>	Absorb or cover with earth, sand or other inert non-combustible absorbent material. Scrape up and place into containers for disposal.
<b>Large Spills</b>	<p>Immediately contact emergency personnel. In all cases stop the source of leak only when it is safe to do so.</p> <p>LAND: Contain the spill with dikes of earth or sand. Do not allow to enter waterways or sewer. Recover as much liquid as possible for re-use/reclamation. Scrape up residual product and diking material and either reclaim or dispose of.</p> <p>WATER: The emulsion will slowly begin to disperse in water. Contain as much as possible with booms and begin recovery as soon as possible. Notify local and state authorities and the National Response Center if required.</p>

<b>7. Handling and Storage</b>	
<b>Handling</b>	<p>HOT PRODUCT: Avoid breathing fumes or vapors – hydrogen sulfide can accumulate in bulk transport or storage tanks. Wear appropriate PPE to avoid skin, face and eye contact, especially when opening hatches or vents, since the bulk transporter or tank may be pressurized.</p> <p>COOL PRODUCT: Avoid breathing fumes or vapors. Wear appropriate PPE when opening hatches or vents in case pressure has built up in the bulk transporter or storage tank.</p>
<b>Storage</b>	<p>HEATING: Avoid overheating product -- temperature &gt;200°F (93°C). Keep heating coils and flues in storage tanks and trucks covered with material when heating.</p> <p>COLD WEATHER: Protect product from freezing.</p> <p>GENERAL: Empty containers will contain product residues. Do not cut, grind, weld or expose containers to potential ignition sources unless precautions are taken against these hazards.</p>



<b>SAFETY DATA SHEET</b> <b>Emulsified Asphalt</b> <b>Cationic, All Grades</b>
--

<b>8. Exposure Controls/Personal Protection</b>		
<b>OCCUPATIONAL EXPOSURE LIMITS</b>		
<b>SUBSTANCE</b>	<b>CAS NO.</b>	<b>TIME/TYPE</b>
Asphalt	8052-42-4	ACGIH 8-hr TWA: 0.5 mg/m <sup>3</sup>
Fuel Oil Flux	68334-30-5	ACGIH TWA: 100 mg/m <sup>3</sup>
Stoddard Solvent	8052-41-3	ACGIH TWA: 100 ppm
		OSHA PEL TWA: 500 ppm
		NIOSH PEL TWA: 350 mg/m <sup>3</sup>
		NIOSH Ceiling: 1800 mg/m <sup>3</sup> [15 minute]
Hydrogen Sulfide	7783-06-4	ACGIH TWA: 1 ppm, STEL: 5 ppm
		OSHA PEL 8-hr: 10 ppm / 14 mg/m <sup>3</sup> , 15-min STEL: 15 ppm / 21 mg/m <sup>3</sup>
<b>Engineering Controls</b>		Provide exhaust ventilation or other engineering controls in enclosed areas to keep airborne vapor concentrations below respective exposure limits.
<b>Personal Protection (PPE)</b>		
<b>General</b>		PPE should be based on a risk assessment of the work area. In all cases use good personal hygiene.
<b>Skin</b>		Work clothes, work boots and work gloves should be worn.
<b>Eye</b>		OSHA- approved safety glasses. A suitable eyewash station should be available
<b>Respiratory</b>		With adequate ventilation a respirator is not required. If the risk assessment indicates a respirator is required a NIOSH/MSA approved air-purifying particulate respirator suitable for dusts, fumes and mists should be used. Respirator selection must be based on known or anticipated exposure limits for the hazards and the safe working limits of the respirator



<b>SAFETY DATA SHEET</b> <b>Emulsified Asphalt</b> <b>Cationic, All Grades</b>
--

<b>9. Physical and Chemical Properties</b>	
Physical State	Liquid
Color	Brown-Black
Odor	Mild Petroleum-like
pH	2-4
Melting Point, °F (°C)	Not Applicable
Freezing Point, °F (°C)	32 (0)
Boiling Point, °F (°C)	212 (100)
Flash Point, °F (°C)	Not Applicable
Evaporation Rate	INA
Flammability	NFPA Class III-B combustible material
Lower Flammable Limit, % by Vol.	Not Applicable
Upper Flammable Limit, % by Vol.	Not Applicable
Vapor Pressure	INA
Vapor Density	>1 (Air = 1)
Relative Density	>1 (Water = 1)
Solubilities	Water: Dispersable
Partition Coefficient (n-octanol/water)	INA
Auto-Ignition Temperature	Not applicable
Decomposition Temperature	Not applicable
Viscosity	See AASHTO M-208

<b>10. Stability and Reactivity</b>	
Reactivity	Not reactive under normal conditions
Chemical Stability	Stable under normal conditions
Possibility of Hazardous Reaction	Minimal
Conditions to Avoid	Excessive heat, freezing, sources of ignition.
Incompatible Materials	Strong oxidizers such as nitrates, chlorates, peroxides
Hazardous Decomposition Products	Combustion produces carbon dioxide, carbon monoxide, oxides of sulfur and/or nitrogen, unburned hydrocarbons. At elevated temperatures hydrogen sulfide and other sulfur gases may be produced.



<b>SAFETY DATA SHEET</b> <b>Emulsified Asphalt</b> <b>Cationic, All Grades</b>
--

<b>11. Toxicological Information</b>	
<b>Major Routes of Entry</b>	Skin Contact
<b>Symptoms related to</b>	
<b>Skin</b>	Irritation with reddening, itching, burning feeling and/or swelling. Contains component(s) that may cause allergic skin reactions. Repeated skin contact may cause harmful effects to other parts of the body. Hot material may cause thermal burns
<b>Eye</b>	Irritation with tearing, redness, stinging or burning feeling. Hot material can cause thermal burns with eye tissue destruction and possible permanent injury.
<b>Ingestion</b>	Stomach and/or intestinal pain, nausea, vomiting and/or diarrhea
<b>Inhalation</b>	No significant adverse health effects expected during normal exposure to product at room temperature. Fumes from hot product may cause irritation to the respiratory tract.
<b>Short Term Exposure</b>	
<b>Immediate</b>	HOT PRODUCT: May cause skin and respiratory tract irritation. COOL PRODUCT: No significant adverse effects expected.
<b>Chronic</b>	HOT PRODUCT: May cause skin and respiratory tract irritation. COOL PRODUCT: No significant adverse effects expected.
<b>Long Term Exposure</b>	
<b>Immediate</b>	HOT PRODUCT: may cause dermatitis, acne and/or photosensitization of the skin. May cause respiratory tract irritation. COOL PRODUCT: No significant adverse effects expected.
<b>Chronic</b>	HOT PRODUCT: May cause dermatitis, acne, and/or photosensitization of the skin. May cause respiratory tract irritation. COOL PRODUCT: No significant adverse effects expected.
<b>Toxicity Data</b>	
<b>Asphalt</b>	Oral LD <sub>50</sub> : Acute >5000 mg/kg [rat] Dermal LD <sub>50</sub> : >2000 mg/kg [rabbit]
<b>Fuel Oil Flux</b>	Octane (111-65-9): Inhalation LC <sub>50</sub> : 118mg/l 4 hrs [rat] n-Nonane (111-84-2): Inhalation LC <sub>50</sub> : 3200 mg/l 4 hrs [rat] n-Heptane (14282-5) Inhalation LC <sub>50</sub> : 103 mg/l 4 hrs [rat] Naphthalene (91-20-3): Dermal LD <sub>50</sub> : >2 g/kg [rabbit] Oral LD <sub>50</sub> : 450 mg/kg [rat]
<b>Stoddard Solvent</b>	Inhalation LC <sub>50</sub> : >20 mg/l 1 hr [rat] Oral LD <sub>50</sub> : >7000 mg/kg [rat] Dermal LD <sub>50</sub> : >2000 mg/kg [rabbit]
<b>Hydrogen Sulfide</b>	Intraperitoneal LD <sub>50</sub> : 2300 µg/kg [rat] Intravenous LD <sub>50</sub> : 270 µg/kg [rat] Inhalation (Vapor) LC <sub>50</sub> : 820 mg/kg 3 hrs [rat] Inhalation (Gas) LC <sub>50</sub> : 712 ppm 1 hr [rat]



<b>SAFETY DATA SHEET</b> <b>Emulsified Asphalt</b> <b>Cationic, All Grades</b>
--

<b>11. Toxicological Information, continued</b>	
<b>Carcinogenic Data</b>	
<b>Asphalt</b>	IARC: Determined that there is sufficient evidence that extracts of stream and air refined bitumens are carcinogenic in animals but there is inadequate evidence that bitumens alone are carcinogenic to humans. NTP: Reasonably expected to be a carcinogen. ACGIH: A4 – Not classifiable as a carcinogen. OSHA – Select Carcinogens: Listed
<b>Fuel Oil Flux</b>	ACGIH (Fuels, diesel 68334-30-5): A3 confirmed carcinogen with unknown relevance to humans
<b>Stoddard Solvent</b>	No data available to indicate product or any components present at greater than 0.1% are carcinogenic
<b>Hydrogen Sulfide</b>	No known significant effects
<b>Target Organs</b>	Skin, Eyes, Respiratory System



<b>SAFETY DATA SHEET</b> <b>Emulsified Asphalt</b> <b>Cationic, All Grades</b>
--

<b>12. Ecological Information</b>	
<b>Ecotoxicity</b>	Harmful to aquatic organisms
<b>Persistence &amp; Biodegradability</b>	Expected to have a low rate of biodegradation
<b>Bioaccumulative Potential</b>	Expected to have a low rate of bioaccumulation
<b>Mobility in Soil</b>	Not mobile in soil – will not penetrate to a significant depth.

<b>13. Disposal Considerations</b>	
<b>RCRA Classification</b>	The product as supplied is not considered a hazardous waste. The hazard characteristic and regulatory waste stream classification can change with product use. It is the responsibility of the user to determine at the time of disposal whether the material is a hazardous waste subject to RCRA or not.
<b>Waste Disposal</b>	Disposal of this product, solutions and any by-products must comply with Local, State and Federal Regulations

<b>14. Transportation Information</b>						
Type	UN Number	Proper Shipping Name	Class	PG*	Label	Other
USDOT (Non-bulk)			Not Regulated			
USDOT (Bulk)			Not Regulated			
IATA-DGR			Not Regulated			
IMDG			Not Regulated			

\*PG = Packing Group





<b>SAFETY DATA SHEET</b> <b>Emulsified Asphalt</b> <b>Cationic, All Grades</b>
--

<b>15. Regulatory Information</b>	
<b>TSCA Inventory</b>	This product and/or its components are listed on the Toxic Substances Control Act (TSCA) Inventory
<b>OSHA Hazard Communication Standard</b>	This product has been determined to be hazardous as defined in the OSHA Hazard Communication Standard
<b>SARA 302 Emergency Planning and Notification</b>	Extremely Hazardous Substances (40 CFR 302.4, 40 CFR 355) identified in this product: Hydrogen Sulfide (500 lb TPQ)
<b>SARA 304 Emergency Planning and Notification</b>	Extremely Hazardous Substances or CERCLA Hazardous Substances which in the case of spill may be subject to reporting requirements; Hydrogen Sulfide (100 lb. Final RQ)
<b>SARA 311/312 Emergency Planning and Notification</b>	EPA Hazard Category: Acute
<b>CERCLA</b>	CERCLA requires notification to the National Response Center of the release of "hazardous substances" equal to or greater than the RQ listed in 40 CFR 302.4: NONE
<b>RCRA</b>	The product as supplied is not considered a hazardous waste. The hazard characteristic and regulatory waste stream classification can change with product use. It is the responsibility of the user to determine at the time of disposal whether the material is a hazardous waste subject to RCRA or not.
<b>Clean Water Act</b>	This product is classified as an oil under Section 311 of the CWA. Discharges or spills which produce a visible oil sheen on waters of the United States or adjoining shorelines or conduits leading into surface waters must be reported to the National Response Center at 1-800-424-8802. Local and state regulations may be more restrictive and require additional reporting.
<b>Oil Pollution Act</b>	This product is classified as an oil under the OPA. Discharges or spills which produce a visible oil sheen on waters of the United States or adjoining shorelines or conduits leading into surface waters must be reported to the National Response Center at 1-800-424-8802. Local and state regulations may be more restrictive and require additional reporting.
<b>Clean Air Act</b>	This product contains the following components designated as hazardous, toxic or flammable air pollutants under Section 112 of the CAA: NONE
<b>California Proposition 65</b>	This material contains the following components which are known to the State of California to cause cancer, birth defects or other reproductive harm: Polynuclear Aromatic Hydrocarbons (4-6 member condensed rings)
<b>New Jersey Right-To-Know</b>	For New Jersey RTK labeling requirements refer to components listed in Section 3
<b>Additional Regulatory Remarks</b>	None



<b>SAFETY DATA SHEET</b> <b>Emulsified Asphalt</b> <b>Cationic, All Grades</b>
--

<b>16. Other Information</b>	
Date Prepared	November 2016
Revision Number	1
Prepared By	
<b>Abbreviations</b>	
=, eq	Equal to
>	Greater than
<	Less than
INA	Information not available
NE	Not Established
ACGIH	American Conference of Government Industrial Hygienists
AIHA	American Industrial Hygiene Association
AASHTO	American Association of State Highway Transportation Officials
CAA	Clean Air Act
CAS	Chemical Abstract Service
CERCLA	Comprehensive Environmental Response, Compensation and Liability Act of 1980
CFR	Code of Federal Regulations
CWA	Clean Water Act
DGR	Dangerous Goods Regulations
EPA	U. S. Environmental Protection Agency
HMIS	Hazardous Materials Identification System
IARC	International Agency for Research on Cancer
IATA	International Air Transport Association
IMDG	International Maritime Dangerous Goods
MSA	Mine Safety Administration
NFPA	National Fire Protection Administration
NIOSH	National Institute of Occupational Health and Safety
NTP	National Toxicology Program
OPA	Oil Pollution Act of 1990
OSHA	Occupational Safety and Health Administration
PEL	Permissible Exposure Limits
RCRA	Resource Conservation and Recovery Act
SARA	Superfund Amendments and Reauthorization Act of 1986
STEL	Short Term Exposure Limit
TSCA	Toxic Substances Control Act
TWA	Time Weighted Average



**SAFETY DATA SHEET**  
**Emulsified Asphalt**  
**Cationic, All Grades**

**DISCLAIMER**

The information contained in this SDS was obtained from sources believed to be reliable and is considered to be accurate as of the data of preparation of this SDS. However, the information is provided without warranty, express or implied, regarding its accuracy. Some information and conclusions presented in this SDS are from sources other than direct test data. The SDS was prepared for and is to be used only for this product. If this product is used as a component in another product or formulation, this SDS information may not be applicable. This SDS may not be used as a commercial specification sheet of the manufacturer or seller. The conditions or methods of handling storage, use and disposal of this product by the user is beyond our control and the manufacturer does not assume responsibility for and expressly disclaims liability for loss, damage, or expense arising out of or connected in any way with the handling, storage, use, and disposal of this product by the user.

# EF Series

## Fast Dry Low VOC Solvent Based Traffic Paint

### PRODUCT DATA

Product Type: Fast Dry Low VOC Solvent Based  
Product Code: 985691            985697  
Product Color: White            Lead Free Yellow  
Description: SB WHT 150 VOC HWVW1  
                  SB LF YEL 150 VOC  
HWVY3 Specification: WA DOT 9.34.2(4)  
Effective Date: **October 31, 2016**

#### Product Description:

A user friendly, fast drying, low voc solvent based traffic paint suitable for application by airless or air atomized equipment. May be used to stripe roadways, airports and parking lots with or without pressure applied glass beads. It offers all of the benefits of a low VOC solvent based paint, and quickly dries to a no track condition. This product meets WA DOT Specification 9-34.2(4) for Low VOC Solvent based Traffic Paint.

#### Product Advantages:

- Below 150 VOC – use year round
- Product reduces and cleans up with acetone
- Performs equally well on both asphalt and concrete
- Paint demonstrates excellent bead retention
- Keeps traffic control to a minimum when striping
- Can be used for symbols, legends and lane marking

#### Packaging:

This paint is available in 5 gallon pails, 55 gallon drums and 275 gallon totes. Other packaging available on request.

#### Storage:

Shelf life of the unopened product is one year from date of manufacture with proper storage and minimal agitation. Proper storage includes inside or covered, above 35° F (3° C), and out of direct sunlight. Outside storage for short intervals is acceptable.

#### Conditions for Application:

All surfaces must be clean, dry and free from oil, grease, antifreeze, loose sand, aggregate and chipping/peeling existing striping. Any curing compounds used on new concrete must be mechanically abraded off prior to striping. When striping on freshly sealed surfaces use caution as some sealers can affect the curing and adhesion of traffic paint. When in doubt, always test adhesion. For complete drying and minimum dirt retention when striping parking lots, the lots should be closed to traffic for two hours minimum after painting. New asphalt and concrete should be allowed to cure for a minimum of 14 days to maximize adhesion and durability.

#### Coverage:

1 gallon yields 320 feet of 4" stripe @ 15 mils; 400 feet of 4" stripe @ 12 mils.

#### Physical Characteristics:

<b>% Total weight solids:</b>	<b>65% minimum</b>
<b>% Total Pigment solids:</b>	<b>53% maximum</b>
<b>% Viscosity in Krebs Units:</b>	<b>75-85</b>
<b>Weight per gallon:</b>	<b>11.8 lbs./gal min</b>
<b>Contrast ratio 5 wet mils:</b>	<b>0.92 minimum</b>
<b>Reflectance/white:</b>	<b>80 minimum</b>
<b>Reflectance/yellow:</b>	<b>50 minimum</b>
<b>Titanium Dioxide in white:</b>	<b>1 lb. minimum</b>
<b>Titanium Dioxide in yellow:</b>	<b>0.2 lbs. minimum</b>

**Dry Time:** Without drop on glass beads, this paint dries to a lab ASTM D711 no pickup in less than 10 minutes @ 15 mils when ambient and surface temperature are 77° F at 50±5% humidity. When glass beads are applied at a rate of at least 6 pounds per gallon to a 15 mil wet line, the field applied paint will dry to an ASTM D713 no-track in less than 1 minute when applied at the weather conditions above.

**Limitations:** Applying a test strip to determine dry to no- pickup time when the humidity is higher than 65%.  
Cone whenever necessary.

- Do not heat paint in striping system above 60 C.
- Do not apply when temperatures are below 3 C.
- Do not apply when rain is forecast.
- Do not apply when temperatures are near or below the dew point or rain is forecast within 1 hour.
- Do not thin more than 5% with acetone, and then use immediately.

The product data offered herein is, to the best of our knowledge, true and accurate, but all recommendations are made without warranty, expressed or implied. Because the conditions of use are beyond our control, neither Ennis-Flint nor its agents shall be liable for any injury, loss or damage, direct or consequential, arising from the use or the inability to use the product described herein. As Ennis-Flint has neither control over the installation of product described herein nor control of the environmental factors the installed markings are subjected to, there is no guarantee as to the durability or the retroreflective properties of any marking system applied. No person is authorized to make any statement or recommendation not contained in the Product Data, and any such statement or recommendation, if made, shall not bind the Corporation. Further, nothing contained herein shall be construed as a recommendation to use any product in conflict with existing patents, and no license under the claims of any patent is either implied or granted.



# PermaSeal

Heavy Duty Pavement Sealer  
Contractor Grade



Improves pavement appearance  
Restricts water penetration  
Prevents ultra-violet oxidation  
Resists gas, oil and salt  
Increased skid resistance  
Saves you money

*PermaSeal* is a protective coating specially formulated from asphalt clay emulsion. It has excellent weathering properties which resist damage caused by chemicals and other destructive elements. In addition to sealing **out** moisture and ultraviolet oxidation, the coating seals **in** the asphalt binder which keeps the pavement flexible. *PermaSeal* is odorless and contains no skin irritants.

Specifications Bulletin

March 2016

*PermaSeal* heavy duty pavement sealer is produced and distributed locally from a manufacturing plant located in Spokane, Washington.

**Available by the gallon and in bulk quantities.**



Seal coating gives pavement a uniform appearance while filling minor pores and voids in the surface. Seal coating also gives sharp contrast to pavement markings, as shown above.

To reduce long term maintenance expenses, it is recommended that pavement be seal coated every 3 to 5 years, depending on traffic and overall condition of the asphalt.

### *Uses*

*PermaSeal* is specifically designed with the professional contractor in mind. This product is used to seal pavements such as parking lots, driveways, playgrounds, drive-in commercial establishments and any other non-highway asphalt surface.

### *Surface Preparation*

Prior to application, new asphalt must be allowed to cure and consolidate. New hot mix pavement or hot mix patches should cure a minimum of 30 days before seal coating. New cold mix pavements or cold mix patches (containing solvents) should be allowed to cure a minimum of 90 days. Asphalt surfaces should be clean and free of loose stone, dust, grease or other foreign matter. Broom sweeping and pressure washing with water will usually clean ordinary surfaces. Places where grease and oils have accumulated, however, should be scraped or scoured off using a detergent followed by a thorough rinsing with water. Areas soaked with fuel, oil or other petroleum derivatives, which cannot be cleaned satisfactorily, should be replaced. One alternative method would be to grind 1/16" or 1/8" from the surface.

### *Application*

*PermaSeal* material should be stirred to a uniform, homogenous consistency prior to application. A maximum of 25% water by volume is allowable to give the material the consistency suitable for application. *PermaSeal* can be applied by mechanical applicator, squeegee or brush (or a combination of these). A push broom with fine Tampico, nylon or similar fibers is recommended for on textured pavement surfaces for putting down the first coat. Rubber-edged squeegees can also be utilized as long as they deposit the proper amount of material. Mechanical applicators using both brushes and squeegees are suitable along with pressure applicators. With surface dampened, the first coat should be thoroughly worked in the surface voids of the pavement to insure a continuous protective coat. To prevent cracking or checking upon drying, uneven application should be avoided. An excessively heavy coating should also be avoided. A second coat is recommended for heavy traffic areas. If needed, the second coat should be applied once the first coat has satisfactorily dried. It is recommended that the second coat be applied at right angles to the direction of the initial coat wherever possible. The same spreading procedure should be followed in putting down both coats. A fine mist or water spray will improve the ease of applying the second coat if one or more days elapse between the first and second coat. Drying time is directly related to the ambient air temperature and relative humidity as well as other factors such as film thickness, wind velocity, etc. Light traffic may be permitted when dry. Heavy traffic or parking of vehicles should be avoided until the coating has thoroughly cured in order to prevent damage and pick-up.

Apply only in good weather. Do not apply in rain, frost or if rain is forecast within 24 hours, as temperature and humidity affect curing time. Applications on warm, sunny days are recommended. Apply only when the pavement and air temperature is 50° F and rising. Do not use on concrete pavements.

### *Clean Up*

Rinse tools in water before use and wash in soapy water immediately after use. Hardened material can be removed with asphalt and tar remover or mineral spirits.

### *Storage and Handling*

#### **CAUTION**

Do not take internally. Close container after each use. Keep from freezing.

**KEEP OUT OF REACH OF CHILDREN!**

### Shipping Weight

<u>Unit Size</u>	<u>Weight per Unit</u>
55 Gallons	616.0 lbs.
5 Gallons	56.0 lbs.
Bulk	10.5 lbs. / gallon

### Recommended coverage rates for bituminous surfaces are as follows:

#### COVERAGE RATES

<i>Surface Condition</i>	<i>Gallons</i>	<i>Sq. Ft.</i>
<b>Smooth, Dense Pavement</b>	<b>2.0</b>	<b>100</b>
<b>Medium Surface</b>	<b>3.0</b>	<b>100</b>
<b>Rough, Aged Surface</b>	<b>4.5</b>	<b>100</b>
<b>Excessively Rough Surfaces</b>	<b>5.0</b>	<b>100</b>

### Specifications

	<u>Minimum</u>	<u>Maximum</u>	<u>Test Methods</u>
Cone Penetration @ 77F, dmm	340	430	ASTM D217
Non-Volatile Components % Weight	55	70	See Note 1:4
% Non-Volatile Soluble in Trichloroethylene by Wt.	20	15	ASSHTO
Typical Density – lbs/gal	10.0	10.9	
Note 1:4 - Method for determination of non-volatile components. Weight 100 grams of homogenous product into a previously tarred, small ointment can lid. Place in a constant temperature oven at 325°F for 1 ½ hours, cool, re-weigh and calculate non-volatile components.			
Color (as received)	Dark Brown		
Color (cured film)	Deep Black		

### Typical Physical Properties

Color	Black
Drying Time	70° F, 50% RH – 2 hours to touch Firm at 16 hours
Application Temperature	50° F and rising
Flammability	None
Specific Gravity	1.2
Ash Content	34% of solids
Non-Volatile (percent)	58

#### Road Products, Inc.

P.O. Box 11072  
Spokane, WA 99211-1072  
**Phone: (509) 922-1206**  
**Fax: (509) 922-0156**

#### Distributed By:



# PERMASEAL

## Technical Instructions & Specifications

**Product Description:** Permaseal is a mineral filled cationic asphalt emulsion based, seal coat for bituminous pavements at parking lots, schoolyards, drive ways and walk ways. Permaseal provides excellent resistance to abrasion and prevents damage to asphalt from the harmful effects of sunlight and oxidation. Permaseal prevents damage to asphalt pavement due to adverse weather conditions. Permaseal prolongs asphalt pavement life, reduces maintenance costs, and beautifies the pavement by drying to a black and even textured surface coat. THERE ARE NO TOXIC, CARCINOGENIC AGENTS OR ORGANIC SOLVENTS IN PERMASEAL.

**Specifications:** Permaseal is supplied in a concentrate form. Water should be added to permaseal prior to application on asphalt pavements. Specifications for Permaseal are as follows:

Uniformity.....Homogeneous with no separation or coagulation  
that cannot be overcome by moderate agitation.  
Weight per gallon Q 77° F (25° C) ASTM D-244.....10-12 lbs./gal. Residue by  
evaporation ASTM D-2939.....58% - 62% Wet Flow ASTM D-  
2939.....No sagging or flow of undiluted emulsion. Firm Set 24 hour ASTM D-  
2939.....No tendency of film to break, roll or peel. Resistance to water ASTM D-2939.....No  
blistering or tendency to re-emulsify.  
  
Aggregate passing #16 sieve ASTM C-136.....100% Wet Track  
Abrasion test ASTM D-3910.....25g/ft<sup>2</sup> avg.

**Rate of Application:** Rate of application for Permaseal may vary with the texture, porosity and age of the asphalt pavement to be sealed. The following application rates are general recommendations: (Manufacturer recommends 2 coats of Permaseal)

1 coat Permaseal, smooth pavement .015 to 0.2 gallons per square yard

2 coat Permaseal, rough pavement

First Coat.....0.2 gallons / sq.yd.

Second Coat.....0.15 gallons / sq.yd.

Sealcoats are affected greatly by weather conditions, especially during construction. The ideal conditions are a warm, sunny day with low humidity. Humidity and cool weather will delay the curing time and cause the seal coat to be tender for a longer period of time making it more susceptible to damage by traffic. Rain can cause major problems when seal coating. If the asphalt binder has not cured, it can become diluted and rise above the top of the cover aggregate. After the water evaporates, asphalt may cover the entire surface causing tires to pick up aggregate or track the binder across the surface. Never seal coat when showers are threatening. Ideal temperature for seal coating is 60 degrees and rising.

Wednesday, April 28, 2021

**Subject: City of Moscow Slurry Seal-2021**  
**Contractor: Blackline Inc.**

**1. Material Evaluation**

**Table I: Materials List**

Material	Source
CQS-1HP Emulsion	Idaho Asphalt Supply, Hauser Terminal
Type II Slurry Aggregate	Atlas Sand & Rock Pit-Lewiston, ID

The properties of the CQS-1HP emulsion met AASHTO M208 Specifications and are listed in Table II:

**Table II: Emulsion Test Results**

Test	Method	Spec	Result
Viscosity, Saybolt Furol at 25°C (77°F), sec	AASHTO T59	20-100	<b>35</b>
Particle Charge	AASHTO T59	Positive	<b>Positive</b>
Sieve Test, %	AASHTO T59	0.10 max	<b>0.02</b>
Residue by Distillation, %	AASHTO T59	62.0 min	<b>65.1</b>
<b>Tests on Distillation Residue</b>			
Penetration at 25°C (77°F), 100g, 5 s, 0.1mm	AASHTO T49	40-90	<b>57</b>
Elastic Recovery, 10°C (50°F), %	AASHTO T301	50	<b>80</b>
Softening Point, °F	AASHTO T53	135	<b>138</b>
Ash content, %	AASHTO T59	1 max	<b>0.01</b>
Polymer Content, %	-----	3.0	<b>3.0+</b>

The aggregate met ISSA type II aggregate gradation and City of Moscow § 2.4, Table 1 Gradation. The aggregate is 100% crushed stone, free of organic material, clay balls, or other deleterious materials in accordance with City of Moscow § 2.2.A.

**Table III: Aggregate Gradation**

Sieve Size		% Passing	City of Moscow § 2.4, Table 1		Stockpile Tolerances
Mesh	(mm)		% Passing		
3/8	9.5	<b>100</b>	100	100	±5%
#4	4.75	<b>100</b>	90	100	±5%
#8	2.36	<b>81</b>	65	90	±5%
#16	1.18	<b>51</b>	45	70	±5%
#30	0.60	<b>34</b>	30	50	±5%
#50	0.30	<b>24</b>	18	30	±4%
#100	0.15	<b>17</b>	10	21	±3%
#200	0.075	<b>13.9</b>	5	15	±2%

**Table IV: Aggregate Properties (City of Moscow § 2.2- B, C,D,E)**

Test	Test Method	Requirement	Result
Sand Equivalent	AASHTO T176	45 Min.	71
LA Abrasion (%)	AASHTO T96	35% Max	19*
Sodium Sulfate Soundness (%)	AASHTO T104	15% Max	4*

\*Tested by All West Testing & Engineering 3/25/2021

**Table V: Bulking Effect (City of Moscow § 2.7.A, Table 1)**

Moisture (%)	Unit Weight (lbs/ft <sup>3</sup> )
0	121.8
1	116.9
2	115.1
3	115.5
4	115.6
5	116.7
6	119.7
7	124.5
8	125.8
9	127.6
10	128.3

**2. Job Mix Formula**

A job mix formula that was determined by a series of mix time and cohesion tests is listed in Table V. The evaluation results on the job mix formulation appear in Table VI.

**Table V: Job Mix Formulation**

Component	% on Dry Aggregate Basis	Range	City of Moscow § 2.7. A
Portland Cement (Type I)	0.5	±0.5	0.0-3.0%
Aluminum Sulfate	0	0-0.3%	As needed
Water†	8	±3.0*	As needed*
Emulsion	13	±1.0	--
Residual Asphalt	8.46	±0.65	7.5 – 13.5%

\* As needed for field performance

†Water is potable and free from harmful salts and contaminants (City of Moscow § 2.5 A)

**Table VI: Job Mix Formulation Evaluation Results (City of Moscow § 2.7. A)**

Test	ISSA TB No.	Requirement	Result
Slurry Seal Consistency, cm	TB-106	2.0-3.0	2.4
Wet Cohesion, kg-cm 30 Minutes (Set) 60 Minutes (Traffic)	TB-139	12 Min 20 Min	12 (Normal) 20 (Near Spin)
Excess Asphalt by LWT, g/ft <sup>2</sup>	TB-109	50 Max	30.8
Wet Stripping	TB-114	Pass (90% Min)	Pass (> 95%)
Wet Track Abrasion, g/ft <sup>2</sup> One-hour Soak	TB-100	75 Max	16.3
Mix Time, sec @ 77°F (25°C) @ 100°F (38°C) Expected	TB-113	180 seconds Min	180+ 180+

\*Under lab condition: 74°F and 30% humidity

†Machine: Hobart A-120 Time: 405 seconds

‡Cycles: 1000 Loading Weight: 125 lbs

Note: These results were obtained under laboratory conditions and were performed on materials submitted using accepted procedures. No warranty, express or implied, is made. Variations in materials, production equipment, and environmental conditions at the time of application sometimes require adjustments in formulation to maintain optimum performance.

Huachun Zhai, Ph.D., P.E.  
VP of Product Quality and Innovation  
4/28/2021





# CERTIFICATE OF LIABILITY INSURANCE

DATE (MM/DD/YYYY)

4/16/2024

THIS CERTIFICATE IS ISSUED AS A MATTER OF INFORMATION ONLY AND CONFERS NO RIGHTS UPON THE CERTIFICATE HOLDER. THIS CERTIFICATE DOES NOT AFFIRMATIVELY OR NEGATIVELY AMEND, EXTEND OR ALTER THE COVERAGE AFFORDED BY THE POLICIES BELOW. THIS CERTIFICATE OF INSURANCE DOES NOT CONSTITUTE A CONTRACT BETWEEN THE ISSUING INSURER(S), AUTHORIZED REPRESENTATIVE OR PRODUCER, AND THE CERTIFICATE HOLDER.

**IMPORTANT:** If the certificate holder is an **ADDITIONAL INSURED**, the policy(ies) must have **ADDITIONAL INSURED** provisions or be endorsed. If **SUBROGATION IS WAIVED**, subject to the terms and conditions of the policy, certain policies may require an endorsement. A statement on this certificate does not confer rights to the certificate holder in lieu of such endorsement(s).

<b>PRODUCER</b> Alliant Insurance Services, Inc. 818 W Riverside Ave Ste 800 Spokane WA 99201	<b>CONTACT NAME:</b> Jessica Akeens, CISR Elite <b>PHONE (A/C, No, Ext):</b> 509-570-1229 <b>E-MAIL ADDRESS:</b> Jessica.Akeens@Alliant.com	<b>FAX (A/C, No):</b> 509-325-1803
	<b>INSURER(S) AFFORDING COVERAGE</b>	
License#: 0C36861 ARROCON-04	<b>INSURER A:</b> Western National Assurance Com	<b>NAIC #</b> 24465
<b>INSURED</b> Arrow Concrete & Asphalt Specialties, LLC 9915 E Trent Avenue Spokane Valley WA 99206-4204	<b>INSURER B:</b> Western National Mutual Insura	15377
	<b>INSURER C:</b> SiriusPoint Specialty Insuranc	16820
	<b>INSURER D:</b>	
	<b>INSURER E:</b>	
	<b>INSURER F:</b>	

**COVERAGES**

CERTIFICATE NUMBER: 412814600

REVISION NUMBER:

THIS IS TO CERTIFY THAT THE POLICIES OF INSURANCE LISTED BELOW HAVE BEEN ISSUED TO THE INSURED NAMED ABOVE FOR THE POLICY PERIOD INDICATED. NOTWITHSTANDING ANY REQUIREMENT, TERM OR CONDITION OF ANY CONTRACT OR OTHER DOCUMENT WITH RESPECT TO WHICH THIS CERTIFICATE MAY BE ISSUED OR MAY PERTAIN, THE INSURANCE AFFORDED BY THE POLICIES DESCRIBED HEREIN IS SUBJECT TO ALL THE TERMS, EXCLUSIONS AND CONDITIONS OF SUCH POLICIES. LIMITS SHOWN MAY HAVE BEEN REDUCED BY PAID CLAIMS.

INSR LTR	TYPE OF INSURANCE	ADDL INSD	SUBR WVD	POLICY NUMBER	POLICY EFF (MM/DD/YYYY)	POLICY EXP (MM/DD/YYYY)	LIMITS
A	<input checked="" type="checkbox"/> <b>COMMERCIAL GENERAL LIABILITY</b> <input type="checkbox"/> CLAIMS-MADE <input checked="" type="checkbox"/> OCCUR GEN'L AGGREGATE LIMIT APPLIES PER: <input checked="" type="checkbox"/> POLICY <input checked="" type="checkbox"/> PRO-JECT <input type="checkbox"/> LOC OTHER:	Y	Y	CPP125437103	12/31/2023	12/31/2024	EACH OCCURRENCE \$ 1,000,000 DAMAGE TO RENTED PREMISES (Ea occurrence) \$ 300,000 MED EXP (Any one person) \$ 10,000 PERSONAL & ADV INJURY \$ 1,000,000 GENERAL AGGREGATE \$ 2,000,000 PRODUCTS - COMP/OP AGG \$ 2,000,000 BIPD Retention \$ \$10,000
B	<input checked="" type="checkbox"/> <b>AUTOMOBILE LIABILITY</b> <input checked="" type="checkbox"/> ANY AUTO <input type="checkbox"/> OWNED AUTOS ONLY <input type="checkbox"/> SCHEDULED AUTOS <input checked="" type="checkbox"/> HIRED AUTOS ONLY <input checked="" type="checkbox"/> NON-OWNED AUTOS ONLY			CPP125254603	12/31/2023	12/31/2024	COMBINED SINGLE LIMIT (Ea accident) \$ 1,000,000 BODILY INJURY (Per person) \$ BODILY INJURY (Per accident) \$ PROPERTY DAMAGE (Per accident) \$ \$
A	<input checked="" type="checkbox"/> <b>UMBRELLA LIAB</b> <input checked="" type="checkbox"/> OCCUR <input type="checkbox"/> EXCESS LIAB <input type="checkbox"/> CLAIMS-MADE <input type="checkbox"/> DED <input checked="" type="checkbox"/> RETENTION \$ 10,000			UMB104308403	12/31/2023	12/31/2024	EACH OCCURRENCE \$ 5,000,000 AGGREGATE \$ 5,000,000 \$
A	<input checked="" type="checkbox"/> <b>WORKERS COMPENSATION AND EMPLOYERS' LIABILITY</b> ANY PROPRIETOR/PARTNER/EXECUTIVE OFFICER/MEMBER EXCLUDED? (Mandatory in NH) If yes, describe under DESCRIPTION OF OPERATIONS below	Y/N	N/A	CPP125437103	12/31/2023	12/31/2024	<input type="checkbox"/> PER STATUTE <input checked="" type="checkbox"/> OTH-ER WA Stop GAP E.L. EACH ACCIDENT \$ 1,000,000 E.L. DISEASE - EA EMPLOYEE \$ 1,000,000 E.L. DISEASE - POLICY LIMIT \$ 1,000,000
C	Pollution Liability			CPL D000139100	12/31/2023	12/31/2024	Each Occurrence \$ 1,000,000 Aggregate \$ 2,000,000 Retention \$ 10,000

DESCRIPTION OF OPERATIONS / LOCATIONS / VEHICLES (ACORD 101, Additional Remarks Schedule, may be attached if more space is required)

Project: 2024 Off-Street Parking Lot Repair and Maintenance

Please see forms attached.

**CERTIFICATE HOLDER****CANCELLATION**
 City of Spokane  
 808 W. Spokane Blvd.  
 Spokane WA 99201

SHOULD ANY OF THE ABOVE DESCRIBED POLICIES BE CANCELLED BEFORE THE EXPIRATION DATE THEREOF, NOTICE WILL BE DELIVERED IN ACCORDANCE WITH THE POLICY PROVISIONS.

AUTHORIZED REPRESENTATIVE

© 1988-2015 ACORD CORPORATION. All rights reserved.



**Alliant Insurance Services, Inc**  
818 W Riverside Avenue, Suite 800  
Spokane, Washington 99201-0913

Dear Certificate Holder,

We would like to inform you of an important update to our procedures for completing ACORD forms, which is a result of the recent legal case, T-Mobile USA Inc. v. Selective Insurance Company of America.

**\*\*Effective immediately, Alliant Insurance Services Inc. will no longer include specific language in the Description of Operations field on ACORD forms. \*\*** This change ensures compliance with the court's ruling, which emphasizes the legal significance of the information provided on these certificates.

To ensure you have the appropriate coverage, **\*\*we strongly encourage you to review the attached policy endorsements\*\***. These documents provide detailed information about your coverage and should be used to verify that your insurance needs are fully met.

- The Alliant Standard is to only add wording that will identify the Certificate to the Certificate Holder. (Location, Description of Equipment, Contract or Job Number, etc.)
- Any other wording may be construed as modifying the policy and we should let the attached endorsements speak for themselves.
- Even if you are not doing business in Washington State and your state is silent on this issue. Alliant Adopts the position that you may not modify the policy limits on the Certificate.
- All states forbid an agent from issuing a document that is fraudulent, a misrepresentation, or a deceptive act.
- The ACORD Form Instruction Guide says: "Enter limits corresponding to those found on the policy declarations page."

For Additional Details:

Case: T-Mobile USA Inc. v. Selective Insurance Company of America

Summary: In this case, the court ruled that an insurance company is bound by its agent's written representation in a certificate of insurance (COI) that a particular corporation was an additional insured under a given policy. This decision came despite the COI containing disclaimers stating it could not "amend, extend or alter the coverage afforded by" the policy.

The ruling emphasized that if an agent acts with apparent authority and provides a COI stating that a party is an additional insured, the insurer must honor that representation. This case has influenced how COIs are viewed in Washington state, affirming them as valid proof of coverage under certain conditions.

Source:

1. T-Mobile USA Inc. v. Selective Ins. Co. of Am. - Casetext.

<https://casetext.com/case/t-mobile-usa-inc-v-selective-ins-co-of-am-2>.

- (2) T-Mobile USA, Inc. v. Selective Ins. Co. of Am. :: 2019 :: Washington ....

<https://law.justia.com/cases/washington/supreme-court/2019/96500-5.html>.

- (3) T-Mobile USA Inc. v. Selective Insurance Company of America

- Lewis .... <https://bing.com/search?q=Washington+state+court+case+Selective+Insurance+T-Mobile+COI>.

- (4) T-Mobile USA Inc. v. Selective Insurance Company of America

- Lewis .... <https://lewisbrisbois.com/newsroom/articles/t-mobile-usa-inc-v-selective-insurance-company-of-america>.

We understand that this change may require an adjustment in how you manage your insurance documents. Please rest assured that our team is here to assist you with any questions or concerns you may have regarding this update.

Thank you for your attention to this matter and for your continued trust in our services.

Jessica Akeens, CISR Elite  
**Commercial Lines Account Manager**  
CA License No. 0E69948  
Alliant Americas

D (509) 570-1229

F (509) 325-1803

E [Jessica.Akeens@alliant.com](mailto:Jessica.Akeens@alliant.com)

[alliant.com](http://alliant.com)



STATE OF WASHINGTON

Department of Labor & Industries

# Certificate of Workers' Compensation Coverage

January 24, 2024

WA UBI No.	601 619 703
L&I Account ID	518,690-02
Legal Business Name	ARROW CONCRETE & ASPHALT SPECIALTIES LLC
Doing Business As	ARROW CONCRETE & ASPHALT SPE
Workers' Comp Premium Status:	Account is current.
Estimated Workers Reported (See Description Below)	Quarter 3 of Year 2023 "31 to 50 Workers"
Account Representative	Employer Services Help Line, (360) 902-4817
Licensed Contractor?	No

## What does "Estimated Workers Reported" mean?

Estimated workers reported represents the number of full time position requiring at least 480 hours of work per calendar quarter. A single 480 hour position may be filled by one person, or several part time workers.

## Industrial Insurance Information

Employers report and pay premiums each quarter based on hours of employee work already performed, and are liable for premiums found later to be due.

**Industrial insurance accounts have no policy periods, cancellation dates, limitations of coverage or waiver of subrogation** (See [RCW 51.12.050](#) and [51.16.190](#)).



Endorsement No. 10

This endorsement, effective 12/31/2023, forms a part of Policy No: CPL D0001391 00 issued to Arrow Construction Holdings, LLC by SiriusPoint Specialty Insurance Corporation (The Company)

THIS ENDORSEMENT MODIFIES THE INSURANCE PROVIDED UNDER THIS POLICY.  
PLEASE READ IT CAREFULLY.

**ADDITIONAL INSURED SCHEDULE FOR THIRD PARTIES -  
SPECIFIED INSURING AGREEMENTS**

In consideration of the following adjustment of premium: \$0

The INSURED and the Company agree to the following change(s):

Solely with regard to the persons or entities scheduled below, SECTION VII. DEFINITIONS, A. ADDITIONAL INSURED is deleted in its entirety and replaced with the following:

- A. ADDITIONAL INSURED means, when required by written contract, those persons or entities listed in the Schedule below are an ADDITIONAL INSURED solely with regard to the Coverage Sections listed below:

Schedule

State of Washington, and all authorized Purchasers (and their agents, officers, and employees).

Coverage Section(s):

- Coverage A – Contractor's Occurrence Job Site Pollution Coverage
- Coverage D – Contractor's Owned Location Coverage
- Coverage F – Contractor's Occurrence Non-Owned Disposal Site Coverage
- Coverage G – Contractor's Occurrence Transportation Coverage

Coverage is afforded when required by a written contract that is signed by the FIRST NAMED INSURED or an ADDITIONAL NAMED INSURED prior to the date the applicable POLLUTION CONDITION or INDOOR CONTAMINANT CONDITION first commences. The scope and limits of coverage for such person or entity under this Policy shall not exceed what is required by the written contract.

Coverage is provided solely for the above scheduled person's or entity's liability arising out of the FIRST NAMED INSURED's or any ADDITIONAL NAMED INSURED's ownership, maintenance, use, or operation of a COVERED LOCATION, vicarious liability for CONTRACTING SERVICES, or a POLLUTION CONDITION or INDOOR CONTAMINANT CONDITION as applicable. Coverage will only be afforded for such person or entity if that person or entity is named in a lawsuit, petition or regulatory action as a co-defendant with the FIRST NAMED INSURED or any ADDITIONAL NAMED INSURED alleging that it is liable as a result of either the FIRST NAMED INSURED's or any ADDITIONAL NAMED INSURED's ownership, maintenance, use, or operation of a COVERED LOCATION, such person's or entity's vicarious liability for CONTRACTING SERVICES, or a POLLUTION CONDITION or INDOOR CONTAMINANT CONDITION



as applicable. No coverage will be provided under this Policy for an ADDITIONAL INSURED's own negligence or strict liability.

All other terms and conditions remain the same.



Endorsement No. 11

This endorsement, effective 12/31/2023, forms a part of Policy No: CPL D0001391 00 issued to Arrow Construction Holdings, LLC by SiriusPoint Specialty Insurance Corporation (The Company)

THIS ENDORSEMENT MODIFIES THE INSURANCE PROVIDED UNDER THIS POLICY.  
PLEASE READ IT CAREFULLY.

**ADDITIONAL NAMED INSURED SCHEDULE**

In consideration of the following adjustment of premium: \$0

The INSURED and the Company agree to the following change(s):

SECTION VII. DEFINITIONS, B. ADDITIONAL NAMED INSURED is amended by the addition of the following:

The following persons or entities are an ADDITIONAL NAMED INSURED:

Arrow Concrete & Asphalt Specialties, LLC (ACAS)
Road Products, Inc
Arrow Construction Supply, LLC
Partner Constructions Products & Services, LLC

All other terms and conditions remain the same.



Endorsement No. 6

This endorsement, effective 12/31/2023, forms a part of Policy No: CPL D0001391 00 issued to Arrow Construction Holdings, LLC by SiriusPoint Specialty Insurance Corporation (The Company)

THIS ENDORSEMENT MODIFIES THE INSURANCE PROVIDED UNDER THIS POLICY.  
PLEASE READ IT CAREFULLY.

**CANCELLATION - COURTESY NOTIFICATION**

In consideration of the following adjustment of premium: \$0

The INSURED and the Company agree to the following change(s):

SECTION VI. CONDITIONS, F. CANCELLATION is amended by the addition of the following:

If the Company cancels this Policy before the expiration date, the Company will mail written notice to the entity(ies) listed below that states when, not less than ninety (90) days (ten (10) days for non-payment of premium) thereafter such cancellation will be effective. Failure of the Company in taking such action will not prevent or delay cancellation of this Policy.

Entity(ies) and Contact Address(es)

Entity	Address Line 1	Address Line 2	City	State	Zip
Washington Dept. of Enterprise Services	PO Box 41411		Olympia	WA	98504-141

All other terms and conditions remain the same.



Endorsement No. 9

This endorsement, effective 12/31/2023, forms a part of Policy No: CPL D0001391 00 issued to Arrow Construction Holdings, LLC by SiriusPoint Specialty Insurance Corporation (The Company)

THIS ENDORSEMENT MODIFIES THE INSURANCE PROVIDED UNDER THIS POLICY.  
PLEASE READ IT CAREFULLY.

**LIMIT OF LIABILITY FOR A SPECIFIED JOB SITE**

In consideration of the following adjustment of premium: \$0

The INSURED and the Company agree to the following change(s):

Solely with respect to the JOB SITE(s) identified in the JOB SITE Schedule below and those Coverage Sections where Limits of Liability are shown below, the Each Incident Limit of Liability, Coverage Section Aggregate Limit of Liability and Self-Insured Retention or DEDUCTIBLE PERIOD set forth in Item 3. of the Declarations are deleted in their entirety and replaced with the following:

JOB SITE Schedule:

JOB SITE Name	JOB SITE Address	JOB SITE Contract Number
WA DOT – Roadway Maintenance Products	Locations throughout Washington State – as outlined in the contract on file with the Company.	o Contract No. 07121

COVERAGE SECTION	EACH INCIDENT LIMIT OF LIABILITY	COVERAGE SECTION AGGREGATE LIMIT OF LIABILITY	SELF INSURED RETENTION OR DEDUCTIBLE PERIOD
A. JOB SITE POLLUTION	\$5,000,000	\$5,000,000	\$10,000
<b>B. EMERGENCY EXPENSES</b>			
EMERGENCY REMEDIATION COSTS	\$1,000,000	\$2,000,000	\$10,000
EVACUATION COSTS	\$1,000,000	\$2,000,000	\$10,000
C. POLLUTION PROTECTIVE	\$1,000,000	\$2,000,000	\$10,000
D. OWNED LOCATION	\$1,000,000	\$2,000,000	\$10,000
E. BUSINESS INTERRUPTION	\$1,000,000	\$2,000,000	Three (3) days
F. NON-OWNED DISPOSAL SITE	\$1,000,000	\$2,000,000	\$10,000
G. TRANSPORTATION	\$10,000,000	\$20,000,000	\$10,000

H. SUPPLEMENTAL COVERAGES	\$250,000	\$250,000	\$10,000
---------------------------	-----------	-----------	----------

Item 4. Policy Aggregate Limit of Liability of the Declarations is deleted in its entirety and replaced with the following:

4. POLICY AGGREGATE LIMIT OF LIABILITY: \$20,000,000

Item 8. Retroactive Date of the Declarations is deleted in its entirety and replaced with the following Retroactive Date that applies to the JOB SITE(s) set forth in JOB SITE Schedule above:

RETROACTIVE DATE: 2/9/2022

The Limits of Liability set forth above are inclusive of and not in addition to the Limits of Liability being replaced. The Limits of Liability set forth above are not dedicated and will be reduced by the payment(s) made under this Policy. Nothing contained in this endorsement will operate to reinstate any Limit of Liability set forth in this Policy.

With respect to coverage afforded under this Policy that does not arise out of the JOB SITE(s) set forth in the JOB SITE Schedule above, the Limits of Liability set forth in Items 3. and 4. of the Declarations will apply.

Item 5. Percentage of Limit for Supplemental Legal Costs – Additional Limits of the Declarations is not increased by the Policy Aggregate Limit of Liability set forth in this endorsement. Item 5. Percentage of Limit for Supplemental Legal Costs – Additional Limits of the Declarations applies only to the Item 4. Policy Aggregate Limit of Liability set forth in the Declarations, whether coverage afforded under this Policy arises out of the JOB SITE(s) set forth in the JOB SITE Schedule above, or does not arise out of the JOB SITE(s) set forth in the JOB SITE Schedule above.

All other terms and conditions remain the same.

## BUSINESS AUTO ENHANCEMENT EDGE ENDORSEMENT

The Business Auto Enhancement Edge Endorsement is an optional endorsement that provides coverage enhancements. The following is a summary of broadened coverages provided by this endorsement. No coverage is provided by this summary, refer to the following endorsement for changes in your policy.

<b>SUMMARY OF COVERAGES</b>	<b>PAGE</b>
Accidental Airbag Deployment Coverage	5
Audio, Visual and Data Electronic Equipment – Limit Amended	5
Auto Loan/Lease Gap Coverage	5
Blanket Additional Insured	3
Blanket Waiver of Subrogation	5
Broadened Definition of Insured includes:	
• Newly Acquired Organizations for up to 180 Days	2
• Employees as Insureds	2
• Subsidiaries in Which You Own 50% or More	2
Deductible Waiver for Glass Repair	4
Employee Hired Auto	6
Fellow Employee Coverage	3
Hired Auto Physical Damage Coverage	3, 6
Knowledge of Accident, Claim, Suit or Loss	5
Loss Of Use Expenses - Amended	3
Personal Effects	3
Primary and Noncontributory If Required by a Written Contract or Written Agreement	6
Rental Reimbursement Coverage	4
Supplementary Payments - Amended:	
• Bail Bonds up to \$5,000	3
• Loss of Earnings up to \$500/Day	3
Temporary Substitute Vehicle Physical Damage	2
Towing	3
Transportation Expense Limits – Amended	3
Unintentional Failure to Disclose Hazards	6

**THIS ENDORSEMENT CHANGES THE POLICY. PLEASE READ IT CAREFULLY.**

## **BUSINESS AUTO ENHANCEMENT EDGE ENDORSEMENT**

This endorsement modifies the insurance provided under the following:

### **BUSINESS AUTO COVERAGE FORM**

With respect to the coverage provided by this endorsement, the provisions of the Coverage Form apply unless modified by this endorsement. The SECTIONS of the Business Auto Coverage Form identified in this endorsement will be amended as shown below.

#### **SECTION I – COVERED AUTOS COVERAGE AMENDMENTS**

##### **A. Temporary Substitute Vehicle Physical Damage**

**SECTION I – COVERED AUTOS, C. Certain Trailers, Mobile Equipment And Temporary Substitute Autos** is amended by adding the following:

If a covered “auto” you own is out of service because of its:

- a. Breakdown;
- b. Repair;
- c. Servicing;
- d. “Loss”, or
- e. Destruction;

the Physical Damage Coverages provided by the Business Auto Coverage Form for that disabled covered “auto” are extended to any “auto” you do not own while used with the permission of its owner as a temporary substitute for the covered “auto” that is out of service.

#### **SECTION II – COVERED AUTOS LIABILITY COVERAGE AMENDMENTS**

##### **A. Who Is An Insured**

**SECTION II – COVERED AUTOS LIABILITY COVERAGE, A. Coverage, 1. Who Is An Insured** is amended to add:

- d. Any legally incorporated subsidiary of yours in which you own more than 50% of the voting stock on the effective date of this coverage form.

However, “insured” does not include any subsidiary of yours that is an “insured” under any other automobile liability policy or would be an “insured” under such policy but for termination of such policy or the exhaustion on such policy’s limits of insurance.

- e. Any organization which is newly acquired or formed by you and over which you maintain majority ownership. However, coverage under this provision:

- (1) is afforded only for the first 180 days after you acquire or form the organization or until the end of the policy period, whichever comes first;
- (2) does not apply to “bodily injury” or “property damage” that results from an “accident” that occurred before you formed or acquired the organization;
- (3) does not apply to any newly acquired or formed organization that is a joint venture or partnership; and
- (4) does not apply to an “insured” under any other automobile liability policy or would be an “insured” under such a policy but for termination of such policy or the exhaustion of such policy’s limits of insurance.

- f. Any “employee” of yours is an “insured” while using a covered “auto” you don’t own, hire or borrow in your business or your personal affairs.

- g. Any “employee” of yours is an “insured” while operating a covered “auto” hired or rented under a contract or agreement in the “employee’s” name, with your permission, while performing duties related to the conduct of your business.

**B. Blanket Additional Insured**

**SECTION II – COVERED AUTOS LIABILITY COVERAGE, A. Coverage, 1. Who Is An Insured, paragraph c.** is amended to add the following:

Any person or organization who is required under a written contract or agreement between you and that person or organization, that is signed and executed by you before the “bodily injury” or “property damage” occurs and that is in effect during the policy period, to be named as an additional insured is an “insured” for Liability Coverage, but only for damages to which this insurance applies and only to the extent that persons or organization qualifies as an “insured” under the Who Is An Insured provision contained in Section II.

**C. Liability Coverage Extensions – Supplementary Payments**

**SECTION II – COVERED AUTOS LIABILITY COVERAGE, A. Coverage, 2. Coverage Extensions, a. Supplementary Payments** is amended by replacing subparagraphs (2) and (4) with the following:

- (2) Up to \$5,000 for cost of bail bonds (including bonds for related traffic law violations) required because of an “accident” we cover. We do not have to furnish these bonds.
- (4) All reasonable expenses incurred by the “insured” at our request, including actual loss of earnings up to \$500 a day because of time off from work.

**D. Fellow Employee Coverage**

**SECTION II – COVERED AUTOS LIABILITY COVERAGE, B. Exclusions, 5. Fellow Employee,** the following is added:

<b>Co-Employee</b>	<b>Lawsuit</b>	<b>Defense</b>	<b>Cost</b>
<b>Reimbursement</b>			

If a suit seeking damages for “bodily injury” to any fellow “employee” of the “insured” arising out of and in the course of the fellow “employee’s” employment or while performing duties related to the conduct of your business, or a suit seeking damages brought by the spouse, child, parent, brother or sister of that fellow “employee”, is brought against you, we will reimburse reasonable costs that you incur in the defense of such matters. Any reimbursement made pursuant to this sub-section will be in addition to the limits of liability set forth in the Declarations.

**SECTION III – PHYSICAL DAMAGE COVERAGE AMENDMENTS**

**A. Towing**

**SECTION III – PHYSICAL DAMAGE COVERAGE, A. Coverage, 2. Towing,** is amended by adding the following:

**2. Towing**

We will pay up to \$250 for towing and labor costs incurred each time a covered “auto” is disabled. However, the labor must be performed at the place of disablement. This \$250 limit is reduced by any applicable towing limit shown in the declarations.

Regardless of the number of disablements, the maximum amount we will pay under this endorsement for all towing and labor costs combined during any one year is \$2,500.

**B. Transportation Expense – Limits Amended**

**SECTION III – PHYSICAL DAMAGE COVERAGE, A. Coverage, 4. Coverage Extensions, a. Transportation Expenses** is amended by replacing \$20 per day/\$600 maximum limit with \$50 per day/\$1,000 maximum.

**C. Hired Auto Physical Damage – Loss Of Use Expenses – Limits Amended**

**SECTION III – PHYSICAL DAMAGE COVERAGE, A. Coverage, 4. Coverage Extensions, b. Loss of Use Expenses** is amended by replacing the \$20 per day/\$600 maximum limit with \$50 per day/\$750 maximum limit.

**D. Personal Effects Coverage**

**SECTION III – PHYSICAL DAMAGE COVERAGE, A. Coverage, 4. Coverage Extensions** is amended by adding the following:

**c. Personal Effects**

We will pay up to \$500 for “loss” to personal effects, which are:

- (1) Owned by an “insured”; and
- (2) In or on your covered “auto.”

This coverage applies only in the event of the total theft of your covered “auto.” No deductible applies to this coverage



**E. Glass Repair – Deductible Waiver**

**SECTION III – PHYSICAL DAMAGE COVERAGE, A. Coverage, 3. Glass Breakage – Hitting A Bird Or Animal – Falling Objects Or Missiles,** is amended by adding the following:

No deductible will apply to glass breakage if such glass is repaired, in a manner acceptable to us, rather than replaced.

**F. Hired Auto Physical Damage**

**SECTION III – PHYSICAL DAMAGE COVERAGE, A. Coverage** is amended by adding the following:

**5. Hired Auto Physical Damage**

If hired “autos” are covered “autos” for Liability Coverage and if Comprehensive, Specified Causes of Loss, or Collision coverages are provided under this coverage form for any “auto” you own, then the Physical Damage Coverages provided are extended to “autos” you hire of like kind and use, subject to the following:

- a. The most we will pay for any one “loss” is \$50,000 or the actual cash value or cost to repair or replace, whichever is less, minus a deductible;
- b. The deductible will be equal to the largest deductible applicable to any owned “auto” for that coverage. Any Comprehensive deductible does not apply to “loss” caused by fire or lightning;
- c. Hired Auto Physical Damage coverage is excess over any other collectible insurance; and
- d. Subject to the above limit, deductible and excess provisions we will provide coverage equal to the broadest coverage applicable to any covered “auto” you own.

If a limit for Hired Auto Physical Damage is indicated in the Declarations, then that limit replaces, and is not added to, the \$50,000 limit indicated above.

**G. Rental Reimbursement**

**SECTION III – PHYSICAL DAMAGE COVERAGE A. Coverage,** is amended by adding the following:

**6. Rental Reimbursement**

This coverage applies only to a covered “auto” of the private passenger or light truck type as follows:

- a. We will pay for rental reimbursement expenses incurred by you for the rental of a private passenger or light truck type “auto” because of “loss” to a covered private passenger or light truck type “auto”. Payment applies in addition to the otherwise applicable amount of each coverage you have on a covered private passenger or light truck type “auto.” No deductibles apply to this coverage.
- b. We will pay only for those expenses incurred during the policy period beginning 24 hours after the “loss” and ending, regardless of the policy’s expiration, with the lesser of the following number of days:
  - (1) The number of days reasonably required to repair or replace the covered private passenger or light truck type “auto”. If “loss” is caused by theft, this number of days is added to the number of days it takes to locate the covered private passenger or light truck type “auto” and return it to you; or
  - (2) 30 days.
- c. Our payment is limited to the lesser of the following amounts:
  - (1) Necessary and actual expenses incurred, or
  - (2) \$50 per day, up to a maximum of \$1,000.

- d. This coverage does not apply while there are spare or reserve private passenger or light truck type "autos" available to you for your operations.
- e. If "loss" results from the total theft of a covered "auto" of the private passenger or light truck type, we will pay under this coverage only that amount of your rental reimbursement expenses which is not already provided for under **SECTION III – PHYSICAL DAMAGE COVERAGE, A. Coverage, 4. Coverage Extensions.**

For the purposes of this Rental Reimbursement coverage, light truck is defined as a truck with a gross vehicle weight of 10,000 lbs. or less as defined by the manufacturer as the maximum loaded weight the auto is designed to carry.

**H. Accidental Airbag Deployment Coverage**

**SECTION III – PHYSICAL DAMAGE COVERAGE, A. Coverage** is amended by adding the following:

**7. Accidental Airbag Deployment Coverage**

We will pay to reset or replace factory installed airbag(s) in any covered "auto" for accidental discharge, other than discharge due to a collision loss.

This coverage is applicable only if comprehensive coverage applies to the covered "auto".

This coverage is excess over any other collectible insurance or reimbursement by manufacturer's warranty.

**I. Auto Loan/Lease Gap Coverage**

**SECTION III PHYSICAL DAMAGE COVERAGE, Item A., Coverage,** is amended by adding the following:

**8. Auto Loan/Lease Gap Coverage**

This coverage applies only to a covered "auto" described or designated in the Schedule or in the Declarations as including physical damage coverage.

In the event of a covered total "loss" to a covered "auto" described or designated in the Schedule or in the Declarations, we will pay any unpaid amount due on the lease or loan for a covered "auto" less:

- a. The amount paid under the Physical Damage Coverage Section on the policy; and
- b. Any:
  - (1) Overdue lease/loan payments at the time of the "loss";

- (2) Financial penalties imposed under a lease for excessive use, abnormal wear and tear or high mileage;
- (3) Security deposits not returned by the lessor;
- (4) Costs for extended warranties, Credit Life Insurance, Health, Accident or Disability Insurance purchased with the loan or lease; and
- (5) Carry-over balances from previous loans or leases.

**J. Audio, Visual and Data Electronic Equipment – Limit Amended**

**SECTION III - PHYSICAL DAMAGE COVERAGE, C. Limits of Insurance, 1.b.** is amended by replacing the \$1,000 limit with a \$2,500 limit.

**SECTION IV – BUSINESS AUTO CONDITIONS AMENDMENTS**

**A. Duties In The Event Of Accident, Claim, Suit Or Loss Amended**

**SECTION IV – BUSINESS AUTO CONDITIONS, A. Loss Conditions, 2. Duties In The Event Of Accident, Claim, Suit Or Loss, a.** is amended by adding the following:

This condition applies only when the "accident" or "loss" is known to:

- (1) You, if you are an individual;
- (2) A partner, if you are a partnership;
- (3) An executive officer or insurance manager, if you are a corporation; or
- (4) A member or manager, if you are a limited liability company.

But this section does not amend the provisions relating to notification of police, protection or examination of the property which was subject to the "loss".

**B. Blanket Waiver of Subrogation**

**Section IV – BUSINESS AUTO CONDITIONS, A. Loss Conditions, 5. Transfer of Rights of Recovery Against Others to Us,** is amended by adding the following exception:

However, we waive any right of recovery we may have against any person or organization to the extent required of you by a written contract signed and executed prior to any "accident" or "loss", provided that the "accident" or "loss" arises out of operations contemplated by such contract. The waiver applies only to the person or organization designated in such contract.

**C. Unintentional Failure to Disclose Hazards**

**SECTION IV – BUSINESS AUTO CONDITIONS, B. General Conditions, 2. Concealment, Misrepresentation Or Fraud**, is amended by adding the following paragraph:

If you unintentionally fail to disclose any hazards existing at the inception date of the policy, or during the policy period in connection with any additional hazards, we will not deny coverage under this Coverage Part because of such failure.

**D. Employee Hired Auto**

**SECTION IV – BUSINESS AUTO CONDITIONS, B. General Conditions, 5. Other Insurance**, paragraph **b.** is deleted and replaced by the following:

- b.** For Hired Auto Physical Damage Coverage, the following are deemed to be a covered “auto” you own:
- (1)** Any covered “auto” you lease, hire, rent or borrow.
  - (2)** Any covered “auto” hired or rented by your “employee” under a contract in that individual “employee’s” name, with your permission, while performing duties related to the conduct of your business.

However, any “auto” that is leased, hired, rented or borrowed with a driver is not a covered “auto”.

**E. Primary and Noncontributory If Required By Written Contract or Written Agreement**

**SECTION IV – BUSINESS AUTO CONDITIONS, B. General Conditions, 5. Other Insurance c.**, the following is added and supersedes any provision to the contrary:

This Coverage Form’s Covered Autos Liability Coverage is primary to and will not seek contribution from any other insurance available to an “insured” under your policy provided that:

- (1)** Such “insured” is a Named Insured under such other insurance; and
- (2)** You have agreed in writing in a contract or agreement that this insurance would be primary and would not seek contribution from any other insurance available to such “insured”.

THIS ENDORSEMENT CHANGES THE POLICY. PLEASE READ IT CAREFULLY.

## ADDITIONAL INSURED – CONTRACTORS – OPERATIONS AND COMPLETED OPERATIONS – WITH ADDITIONAL INSURED REQUIREMENT IN CONSTRUCTION CONTRACT

This endorsement modifies insurance provided under the following:

### COMMERCIAL GENERAL LIABILITY COVERAGE PART

#### 1. Additional Insured – Operations

**A. Section II – Who Is An Insured** is amended to include as an additional insured:

- (1) Any person or organization for whom you are performing operations when you and such person or organization have agreed in writing in a contract or agreement that such person or organization be added as an additional insured on your policy; and
- (2) Any other person or organization you are required to add as an additional insured under the contract or agreement described in Paragraph 1. above.

Such person(s) or organization(s) is an additional insured only with respect to liability for "bodily injury", "property damage" or "personal and advertising injury" caused, in whole or in part, by:

- a. Your acts or omissions; or
- b. The acts or omissions of those acting on your behalf;

in the performance of your ongoing operations for the additional insured.

**B. With respect to Additional Insured - Operations**, coverage is limited as follows:

This insurance does not apply to "bodily injury" or "property damage" occurring after:

- (1) All work, including materials, parts or equipment furnished in connection with such work, on the project (other than service, maintenance or repairs) to be performed by or on behalf of the additional insured(s) at the location of the covered operations has been completed; or

- (2) That portion of "your work" out of which the injury or damage arises has been put to its intended use by any person or organization other than another contractor or subcontractor engaged in performing operations for a principal as a part of the same project.

#### 2. Additional Insured – Completed Operations

**A. Section II – Who Is An Insured** is amended to include as an additional insured:

- (1) Any person or organization for whom you are performing operations when you and such person or organization have agreed in writing in a contract or agreement that such person or organization be added as an additional insured on your policy; and
- (2) Any other person or organization you are required to add as an additional insured under the contract or agreement described in Paragraph 1. above.

Such person(s) or organization(s) is an additional insured only with respect to liability for "bodily injury", "property damage" or "personal and advertising injury" caused, in whole or in part, by:

- a. Your acts or omissions; or
- b. The acts or omissions of those acting on your behalf;

and included in the "products-completed operations hazard".

**B.** With respect to **Additional Insured – Completed Operations**, coverage is limited as follows:

- (1) A person or organization’s status as an insured under Additional Insured – Completed Operations continues only for the period of time required by any written contract or agreement.
- (2) The insurance provided to the additional insured does not apply to “bodily injury”, “property damage” or “personal and advertising injury” arising out of “your work” for which a consolidated (wrap-up) insurance program has been provided by the prime contractor-project manager or owner of the construction project in which you are involved.

**3. Primary and Noncontributory**

The following is added to the **Other Insurance Condition** and supersedes any provision to the contrary:

**Primary And Noncontributory Insurance**

This insurance is primary to and will not seek contribution from any other insurance available to an additional insured under your policy provided that:

- (1) The additional insured is a Named Insured under such other insurance; and
- (2) You have agreed in writing in a contract or agreement that this insurance would be primary and would not seek contribution from any other insurance available to the additional insured.

**4. Other Provisions Applicable to Additional Insured – Operations and Additional Insured – Completed Operations**

- A.** The Amendment of Insured Contract Definition (Endorsement CG 24 26) does not apply to an additional insured.
- B.** The coverage provided under Paragraph **f.** of the definition of “insured contract” under **Section V – Definitions** does not apply to an additional insured under this endorsement unless required by a written contract or agreement.
- C.** The insurance afforded to such additional insured only applies to the extent permitted by law; and

If coverage provided to the additional insured is required by a contract or agreement, the insurance afforded to such additional insured will not be broader than that which you are required by the contract or agreement to provide for such additional insured.

**D.** With respect to the insurance afforded to these additional insureds, the following is added to **Section III – Limits Of Insurance**:

If coverage provided to the additional insured is required by a contract or agreement, the most we will pay on behalf of the additional insured is:

- (1) The minimum amount required by the contract or agreement; or
- (2) The Limits of Insurance shown in the Declarations;

whichever is less.

This endorsement shall not increase the applicable Limits of Insurance shown in the Declarations.

**E.** With respect to the insurance afforded to these additional insureds, the following additional exclusion applies:

This insurance does not apply to:

“Bodily injury”, “property damage” or “personal and advertising injury” arising out of the rendering of, or the failure to render, any professional architectural, engineering or surveying services, including:

- (1) The preparing, approving, or failing to prepare or approve, maps, shop drawings, opinions, reports, surveys, field orders, change orders or drawings and specifications; or
- (2) Supervisory, inspection, architectural or engineering activities.

This exclusion applies even if the claims against an additional insured allege negligence or other wrongdoing in the supervision, hiring, employment, training or monitoring of others by that insured, if the “occurrence” which caused the “bodily injury” or “property damage”, or the offense which caused the “personal and advertising injury”, involved the rendering of or failure to render any professional services by you with respect to your providing engineering, architectural or surveying services in your capacity as an engineer, architect or surveyor.



**ENDORSEMENT FOR  
MOTOR CARRIER POLICIES OF INSURANCE FOR PUBLIC LIABILITY  
UNDER SECTIONS 29 AND 30 OF THE MOTOR CARRIER ACT OF 1980**

Issued to ARROW CONSTRUCTION HOLDINGS, LLC of WA

Dated at 12:00 NOON this 31 day of JANUARY, 20 24

Amending Policy No. CPP 1252546 04 Effective Date DECEMBER 31, 2023

Name of Insurance Company Western National Mutual Insurance Company

Counter signed by  \_\_\_\_\_  
Authorized Company Representative

The policy to which this endorsement is attached provides primary or excess insurance, as indicated by "[X]," for the limits shown:  
 This insurance is primary and the company shall not be liable for amounts in excess of \$ 750,000 for each accident.  
 This insurance is excess and the company shall not be liable for amounts in excess of \$ \_\_\_\_\_ for each accident in excess of the underlying limit of \$ \_\_\_\_\_ for each accident.

Whenever required by the Federal Motor Carrier Safety Administration (FMCSA), the company agrees to furnish the FMCSA a duplicate of said policy and all its endorsements. The company also agrees, upon telephone request by an authorized representative of the FMCSA, to verify that the policy is in force as of a particular date. The telephone number to call is: 952-835-5350.

Cancellation of this endorsement may be effected by the company of the insured by giving (1) thirty-five (35) days notice in writing to the other party (said 35 days notice to commence from the date the notice is mailed, proof of mailing shall be sufficient proof of notice), and (2) if the insured is subject to the FMCSA's registration requirements under 49 U.S.C. 13901, by providing thirty (30) days notice to the FMCSA (said 30 days notice to commence from the date the notice is received by the FMCSA at its office in Washington, D.C.).

**DEFINITIONS AS USED IN THIS ENDORSEMENT**

Accident includes continuous or repeated exposure to conditions or which results in bodily injury, property damage, or environmental damage which the insured neither expected nor intended.  
Motor Vehicle means a land vehicle, machine, truck, tractor, trailer, or semitrailer propelled or drawn by mechanical power and used on a highway for transporting property, or any combination thereof.  
Bodily Injury means injury to the body, sickness, or disease to any person, including death resulting from any of these.

Property Damage means damage to or loss of use of tangible property.  
Environmental Restoration means restitution for the loss, damage, or destruction of natural resources arising out of the accidental discharge, dispersal, release or escape into or upon the land, atmosphere, watercourse, or body of water, of any commodity transported by a motor carrier. This shall include the cost of removal and the cost of necessary measures taken to minimize or mitigate damage to human health, the natural environment, fish, shellfish, and wildlife.  
Public Liability means liability for bodily injury, property damage, and environmental restoration

The insurance policy to which this endorsement is attached provides *automobile liability insurance and is amended to assure compliance by the insured, within the limits stated herein, as a motor carrier of property, with Sections 29 and 30 of the Motor Carrier Act of 1980 and the rules and regulations of the Federal Motor Carrier Safety Administration (FMCSA).*

judgment, within the limits of liability herein described, irrespective of the financial condition, insolvency or bankruptcy of the insured. However, all terms, conditions, and limitations in the policy to which the endorsement is attached shall remain in full force and effect as binding between the insured and the company. The insured agrees to reimburse the company for any payment made by the company on account of any accident, claim, or suit involving a breach of the terms of the policy, and for any payment that the company would not have been obligated to make under the provisions of the policy except for the agreement contained in this endorsement.

In consideration of the premium stated in the policy to which this endorsement is attached, the insurer (the company) agrees to pay, within the limits of liability described herein, any final judgment recovered against the insured for public liability resulting from negligence in the operation, maintenance or use of motor vehicles subject to the financial responsibility requirements of Sections 29 and 30 of the Motor Carrier Act of 1980 regardless of whether or not each motor vehicle is specifically described in the policy and whether or not such negligence occurs on any route or in any territory authorized to be served by the insured or elsewhere. Such insurance as is afforded, for public liability, does not apply to injury to or death of the insured's employees while engaged in the course of their employment, or property transported by the insured, designated as cargo. It is understood and agreed that no condition, provision, stipulation, or limitation contained in the policy, this endorsement, or any other endorsement thereon, or violation thereof, shall relieve the company from liability or from the payment of any final

It is further understood and agreed that, upon failure of the company to pay any final judgment recovered against the insured as provided herein, the judgment creditor may maintain an action in any court of competent jurisdiction against the company to compel such payment.

The limits of the company's liability for the amounts prescribed in this endorsement apply separately to each accident and any payment under the policy because of any one accident shall not operate to reduce the liability of the company for the payment of final judgments resulting from any other accident.

THE SCHEDULE OF LIMITS SHOWN ON THE REVERSE SIDE DOES NOT PROVIDE COVERAGE. The limits shown in the schedule are for information purposes only.

000016 31/326



**SCHEDULE OF LIMITS  
PUBLIC LIABILITY**

Type of carriage	Commodity transported	Jan. 1, 1985
(1) For-hire (In interstate or foreign commerce, with a gross vehicle weight rating of 10,000 or more pounds).	Property (nonhazardous)	\$ 750,000
(2) For-hire and Private (In interstate, foreign, or intrastate commerce, with a gross vehicle weight rating of 10,000 or more pounds).	Hazardous substances, as defined in 49 CFR 171.8, transported in cargo tanks, portable tanks, or hopper-type vehicles with capacities in excess of 3,500 water gallons; or in bulk Divisions 1.1, 1.2, and 1.3 materials, Division 2.3, Hazard Zone A, or Division 6.1, Packing Group 1, Hazard Zone A material; in bulk Division 2.1 or 2.2; or highway route controlled quantities of a Class 7 material, as defined in 49 CFR 173.403.	\$5,000,000
(3) For-hire and Private (In interstate or foreign commerce, in any quantity; or in intrastate commerce, in bulk only; with a gross vehicle weight rating of 10,000 or more pounds).	Oil listed in 49 CFR 172.101; hazardous waste, hazardous materials, and hazardous substances defined in 49 CFR 171.8 and listed in 49 CFR 172.101, but not mentioned in (2) above or (4) below.	\$1,000,000
(4) For-hire and Private (In interstate or foreign commerce, with a gross vehicle weight rating of less than 10,000 pounds).	Any quantity of Division 1.1, 1.2, or 1.3 material; any quantity of a Division 2.3, Hazard Zone A, or Division 6.1, Packing Group 1, Hazard Zone A material; or highway route controlled quantities of a Class 7 material as defined in 49 CFR 173.403.	\$5,000,000

**THIS ENDORSEMENT CHANGES THE POLICY. PLEASE READ IT CAREFULLY.**

## **DESIGNATED CONSTRUCTION PROJECT(S) GENERAL AGGREGATE LIMIT**

This endorsement modifies insurance provided under the following:

COMMERCIAL GENERAL LIABILITY COVERAGE PART

### **SCHEDULE**

<b>Designated Construction Project(s):</b>
Information required to complete this Schedule, if not shown above, will be shown in the Declarations.

- A.** For all sums which the insured becomes legally obligated to pay as damages caused by "occurrences" under Section **I** – Coverage **A**, and for all medical expenses caused by accidents under Section **I** – Coverage **C**, which can be attributed only to ongoing operations at a single designated construction project shown in the Schedule above:
1. A separate Designated Construction Project General Aggregate Limit applies to each designated construction project, and that limit is equal to the amount of the General Aggregate Limit shown in the Declarations.
  2. The Designated Construction Project General Aggregate Limit is the most we will pay for the sum of all damages under Coverage **A**, except damages because of "bodily injury" or "property damage" included in the "products-completed operations hazard", and for medical expenses under Coverage **C** regardless of the number of:
    - a. Insureds;
    - b. Claims made or "suits" brought; or
    - c. Persons or organizations making claims or bringing "suits".
  3. Any payments made under Coverage **A** for damages or under Coverage **C** for medical expenses shall reduce the Designated Construction Project General Aggregate Limit for that designated construction project. Such payments shall not reduce the General Aggregate Limit shown in the Declarations nor shall they reduce any other Designated Construction Project General Aggregate Limit for any other designated construction project shown in the Schedule above.
  4. The limits shown in the Declarations for Each Occurrence, Damage To Premises Rented To You and Medical Expense continue to apply. However, instead of being subject to the General Aggregate Limit shown in the Declarations, such limits will be subject to the applicable Designated Construction Project General Aggregate Limit.



- B.** For all sums which the insured becomes legally obligated to pay as damages caused by "occurrences" under Section **I** – Coverage **A**, and for all medical expenses caused by accidents under Section **I** – Coverage **C**, which cannot be attributed only to ongoing operations at a single designated construction project shown in the Schedule above:
  - 1.** Any payments made under Coverage **A** for damages or under Coverage **C** for medical expenses shall reduce the amount available under the General Aggregate Limit or the Products-completed Operations Aggregate Limit, whichever is applicable; and
  - 2.** Such payments shall not reduce any Designated Construction Project General Aggregate Limit.
- C.** When coverage for liability arising out of the "products-completed operations hazard" is provided, any payments for damages because of "bodily injury" or "property damage" included in the "products-completed operations hazard" will reduce the Products-completed Operations Aggregate Limit, and not reduce the General Aggregate Limit nor the Designated Construction Project General Aggregate Limit.
- D.** If the applicable designated construction project has been abandoned, delayed, or abandoned and then restarted, or if the authorized contracting parties deviate from plans, blueprints, designs, specifications or timetables, the project will still be deemed to be the same construction project.
- E.** The provisions of Section **III** – Limits Of Insurance not otherwise modified by this endorsement shall continue to apply as stipulated.

**THIS ENDORSEMENT CHANGES THE POLICY. PLEASE READ IT CAREFULLY.**

## **SNOW PLOW OPERATIONS COVERAGE**

This endorsement modifies insurance provided under the following:

COMMERCIAL GENERAL LIABILITY COVERAGE PART

Within the "products-completed operations hazard",  
Exclusion **g.** under Section **I – Coverage A – Bodily  
Injury And Property Damage Liability** does not  
apply to any "auto" used for snow plow operations.

THIS ENDORSEMENT CHANGES THE POLICY. PLEASE READ IT CAREFULLY.

## WHO IS AN INSURED AMENDED

This endorsement modifies insurance provided under the following:

### COMMERCIAL LIABILITY UMBRELLA COVERAGE PART

With respect to **SECTION II – WHO IS AN INSURED**, Paragraph 3. is replaced by the following:

3. Any additional insured under any policy of “underlying insurance” will automatically be an insured under this insurance.

Subject to **Section III – Limits Of Insurance**, if coverage provided to the additional insured is required by a contract or agreement, the most we will pay on behalf of the additional insured is:

- a. The minimum amount of insurance required by the contract or agreement, less any amounts payable by any “underlying insurance; or
- b. The amount of insurance available under the applicable Limits of Insurance shown in the Declarations;

whichever is less.

Additional insured coverage provided by this insurance will not be broader than coverage provided by the “underlying insurance”.

**THIS ENDORSEMENT CHANGES THE POLICY. PLEASE READ IT CAREFULLY.**

## **PRIMARY AND NONCONTRIBUTORY – ADDITIONAL INSURED**

This endorsement modifies insurance provided under the following:

### COMMERCIAL LIABILITY UMBRELLA COVERAGE PART

The following is added to **Section IV – Conditions – 5. Other Insurance** and supersedes any provision to the contrary:

#### **Primary And Noncontributory Insurance**

This insurance is primary to and will not seek contribution from any other insurance available to an additional insured under your policy provided that:

- (1) The additional insured is a Named Insured under such other insurance; and
- (2) You have agreed in writing in a contract or agreement that this insurance would be primary and would not seek contribution from any other insurance available to the additional insured.
- (3) The order of payment specified by this endorsement only applies to the extent permitted by law.

The following is added to:

#### **SECTION II – LIMITS OF INSURANCE**

For the purposes of this endorsement only, we will not pay more on behalf of the additional insured and the lesser of:

1. The minimum limits of insurance required in a written contract on a primary and non-contributory basis for such additional insured, but only to the extent the required Limits of Insurance are in excess of the “underlying insurance,” or
2. The Limits of Insurance available after the payment of “ultimate net loss” on any insured’s behalf from any claim or “suit”.

This provision is included within and does not act to increase the limit of insurance stated in the Declarations.

Coverage will not be broader than the coverage provided by the underlying insurance listed in the “Schedule of Underlying Coverages.”

**THIS ENDORSEMENT CHANGES THE POLICY. PLEASE READ IT CAREFULLY.**

**WAIVER OF TRANSFER OF RIGHTS OF RECOVERY  
AGAINST OTHERS TO US**

This endorsement modifies insurance provided under the following:

COMMERCIAL LIABILITY UMBRELLA COVERAGE PART

**SCHEDULE**

**Name Of Person Or Organization:**

As required by written contract

(If no entry appears above, information required to complete this endorsement will be shown in the Declarations as applicable to this endorsement.)

The **Transfer Of Rights Of Recovery Against Others To Us** Condition under **Section IV - Conditions** is amended by the addition of the following:

We waive any right of recovery we may have against the person or organization shown in the Schedule above because of payments we make for injury or damage arising out of your ongoing operations or "your work" done under a contract with that person or organization and included in the "products-completed operations hazard". This waiver applies only to the person or organization shown in the Schedule above.

# WASHINGTON COMMON POLICY CONDITIONS

All Coverage Parts included in this policy are subject to the following conditions.

The conditions in this endorsement replace any similar conditions in the policy that are less favorable to the insured.

## A. Cancellation

1. The first Named Insured shown in the Declarations may cancel this policy by notifying us or the insurance producer in one of the following ways:

- a. Written notice by mail, fax or e-mail;
- b. Surrender of the policy or binder; or
- c. Verbal notice.

Upon receipt of such notice, we will cancel this policy or any binder issued as evidence of coverage, effective on the later of the following:

- a. The date on which notice is received or the policy or binder is surrendered; or
- b. The date of cancellation requested by the first Named Insured.

2. We may cancel this policy by mailing or delivering to the first Named Insured and the first Named Insured's agent or broker written notice of cancellation, including the actual reason for the cancellation, to the last mailing address known to us, at least:

- a. 10 days before the effective date of cancellation if we cancel for nonpayment of premium; or
- b. 45 days before the effective date of cancellation if we cancel for any other reason;

except as provided in Paragraphs 3. and 4. below.

3. We may cancel the Commercial Property Coverage Part and the Capital Assets Program (Output Policy) Coverage Part, if made a part of this policy, by mailing or delivering to the first Named Insured and the first Named Insured's agent or broker written notice of cancellation at least five days before the effective date of cancellation for any structure where two or more of the following conditions exist:

- a. Without reasonable explanation, the structure is unoccupied for more than 60 consecutive days, or at least 65% of the rental units are unoccupied for more than 120 consecutive days, unless the structure is maintained for seasonal occupancy or is under construction or repair;
- b. Without reasonable explanation, progress toward completion of permanent repairs to the structure has not occurred within 60 days after receipt of funds following satisfactory adjustment or adjudication of loss resulting from a fire;
- c. Because of its physical condition, the structure is in danger of collapse;
- d. Because of its physical condition, a vacation or demolition order has been issued for the structure, or it has been declared unsafe in accordance with applicable law;
- e. Fixed and salvageable items have been removed from the structure, indicating an intent to vacate the structure;
- f. Without reasonable explanation, heat, water, sewer and electricity are not furnished for the structure for 60 consecutive days; or
- g. The structure is not maintained in substantial compliance with fire, safety and building codes.

4. If:
  - a. You are an individual;
  - b. A covered auto you own is of the "private passenger type"; and
  - c. The policy does not cover garage, automobile sales agency, repair shop, service station or public parking place operations hazards;

we may cancel the Commercial Automobile Coverage Part by mailing or delivering to the first Named Insured and the first Named Insured's agent or broker written notice of cancellation, including the actual reason for cancellation, to the last mailing address known to us:

- a. At least 10 days before the effective date of cancellation if we cancel for nonpayment of premium; or
  - b. At least 10 days before the effective date of cancellation for any other reason if the policy is in effect less than 30 days; or
  - c. At least 20 days before the effective date of cancellation for other than nonpayment if the policy is in effect 30 days or more; or
  - d. At least 20 days before the effective date of cancellation if the policy is in effect for 60 days or more or is a renewal or continuation policy, and the reason for cancellation is that your driver's license or that of any driver who customarily uses a covered "auto" has been suspended or revoked during policy period.
5. We will also mail or deliver to any mortgage holder, pledgee or other person shown in this policy to have an interest in any loss which may occur under this policy, at their last mailing address known to us, written notice of cancellation, prior to the effective date of cancellation. If cancellation is for reasons other than those contained in Paragraph **A.3.** above, this notice will be the same as that mailed or delivered to the first Named Insured. If cancellation is for a reason contained in Paragraph **A.3.** above, we will mail or deliver this notice at least 20 days prior to the effective date of cancellation.
  6. Notice of cancellation will state the effective date of cancellation. The policy period will end on that date.

7. If this policy is cancelled, we will send the first Named Insured any premium refund due. If we cancel, the refund will be pro rata. If the first Named Insured cancels, the refund will be at least 90% of the pro rata refund unless the following applies:

- a. For Division Two – Equipment Breakdown, if the first Named Insured cancels, the refund will be at least 75% of the pro rata refund.

b. If:

- (1) You are an individual;
  - (2) A covered auto you own is of the "private passenger type";
  - (3) The policy does not cover garage, automobile sales agency, repair shop, service station or public parking place operations hazards; and
  - (4) The first Named Insured cancels;
- the refund will be not less than 90% of any unearned portion not exceeding \$100, plus 95% of any unearned portion over \$100 but not exceeding \$500, and not less than 97% of any unearned portion in excess of \$500.

The cancellation will be effective even if we have not made or offered a refund.

8. If notice is mailed, proof of mailing will be sufficient proof of notice.

#### **B. Changes**

The policy contains all the agreements between you and us concerning the insurance afforded. The first Named Insured shown in the Declarations is authorized to make changes in the terms of this policy with our consent. This policy's terms can be amended or waived only by endorsement issued by us and made a part of this policy.

#### **C. Examination Of Your Books And Records**

We may examine and audit your books and records as they relate to this policy at any time during the policy period and up to three years afterward.

#### **D. Inspection And Surveys**

1. We have the right to:
  - a. Make inspections and surveys at any time;
  - b. Give you reports on the conditions we find; and
  - c. Recommend changes.

2. We are not obligated to make any inspections, surveys, reports or recommendations, and any such actions we do undertake relate only to insurability and the premiums to be charged. We do not make safety inspections. We do not undertake to perform the duty of any person or organization to provide for the health or safety of workers or the public. And we do not warrant that conditions:
  - a. Are safe or healthful; or
  - b. Comply with laws, regulations, codes or standards.
3. Paragraphs 1. and 2. of this condition apply not only to us, but also to any rating, advisory, rate service or similar organization which makes insurance inspections, surveys, reports or recommendations.
4. Paragraph 2. of this condition does not apply to any inspections, surveys, reports or recommendations we may make relative to certification, under state or municipal statutes, ordinances or regulations, of boilers, pressure vessels or elevators.

#### **E. Premiums**

The first Named Insured shown in the Declarations:

1. Is responsible for the payment of all premiums; and
2. Will be the payee for any return premiums we pay.

#### **F. Transfer Of Your Rights And Duties Under This Policy**

Your rights and duties under this policy may not be transferred without our written consent except in the case of death of an individual Named Insured.

If you die, your rights and duties will be transferred to your legal representative but only while acting within the scope of duties as your legal representative. Until your legal representative is appointed, anyone having proper temporary custody of your property will have your rights and duties but only with respect to that property.

#### **G. Nonrenewal**

1. We may elect not to renew this policy by mailing or delivering written notice of nonrenewal, stating the reasons for nonrenewal, to the first Named Insured and the first Named Insured's agent or broker, at their last mailing addresses known to us. We will also mail to any mortgage holder, pledgee or other person shown in this policy to have an interest in any loss which may occur under this policy, at their last mailing address known to us, written notice of nonrenewal. We will mail or deliver these notices at least 45 days before the:
  - a. Expiration of the policy; or
  - b. Anniversary date of this policy if this policy has been written for a term of more than one year.

Otherwise, we will renew this policy unless:

- a. The first Named Insured fails to pay the renewal premium after we have expressed our willingness to renew, including a statement of the renewal premium, to the first Named Insured and the first Named Insured's insurance agent or broker, at least 20 days before the expiration date;
  - b. Other coverage acceptable to the insured has been procured prior to the expiration date of the policy; or
  - c. The policy clearly states that it is not renewable and is for a specific line, subclassification, or type of coverage that is not offered on a renewable basis.
2. If:
    - a. You are an individual;
    - b. A covered auto you own is of the "private passenger type"; and
    - c. The policy does not cover garage, automobile sales agency, repair shop, service station or public parking place operations hazards;



the following applies to nonrenewal of the Commercial Automobile Coverage Part in place of **G.1.**:

- a.** We may elect not to renew or continue this policy by mailing or delivering to you and your agent or broker written notice at least 20 days before the end of the policy period, including the actual reason for nonrenewal. If the policy period is more than one year, we will have the right not to renew or continue it only at an anniversary of its original effective date. If we offer to renew or continue and you do not accept, this policy will terminate at the end of the current policy period. Failure to pay the required renewal or continuation premium when due shall mean that you have not accepted our offer.
- b.** We will not refuse to renew Liability Coverage or Collision Coverage solely because an "insured" has submitted claims under Comprehensive Coverage or Towing And Labor Coverage.
- c.** If we fail to mail or deliver proper notice of nonrenewal and you obtain other insurance, this policy will end on the effective date of that insurance.

**THIS ENDORSEMENT CHANGES THE POLICY. PLEASE READ IT CAREFULLY.**  
**STOP GAP – EMPLOYERS LIABILITY COVERAGE**  
**ENDORSEMENT – WASHINGTON**

This endorsement modifies insurance provided under the following:

COMMERCIAL GENERAL LIABILITY COVERAGE FORM  
**SCHEDULE**

<b>Limits Of Insurance</b>		
Bodily Injury By Accident	\$ 1,000,000	Each Accident
Bodily Injury By Disease	\$ 1,000,000	Aggregate Limit
Bodily Injury By Disease	\$ 1,000,000	Each Employee

(If no entry appears above, the information required to complete this endorsement will be shown in the Declarations as applicable to this endorsement.)

**A. The following is added to Section I - Coverages:**

**COVERAGE - STOP GAP - EMPLOYERS LIABILITY**

**1. Insuring Agreement**

a. We will pay those sums that the insured becomes legally obligated by Washington Law to pay as damages because of "bodily injury by accident" or "bodily injury by disease" to your "employee" to which this insurance applies. We will have the right and duty to defend the insured against any "suit" seeking those damages. However, we will have no duty to defend the insured against any "suit" seeking damages to which this insurance does not apply. We may, at our discretion, investigate any accident and settle any claim or "suit" that may result. But:

- (1) The amount we will pay for damages is limited as described in **Section III - Limits Of Insurance**; and
- (2) Our right and duty to defend end when we have used up the applicable limit of insurance in the payment of judgments or settlements under this coverage.

No other obligation or liability to pay sums or perform acts or services is covered unless explicitly provided for under Supplementary Payments.

**b. This insurance applies to "bodily injury by accident" or "bodily injury by disease" only if:**

**(1) The:**

- (a) "Bodily injury by accident" or "bodily injury by disease" takes place in the "coverage territory";
- (b) "Bodily injury by accident" or "bodily injury by disease" arises out of and in the course of the injured "employee's" employment by you; and
- (c) "Employee", at the time of the injury, was covered under a worker's compensation policy and subject to a "workers compensation law" of Washington; and

**(2) The:**

- (a) "Bodily injury by accident" is caused by an accident that occurs during the policy period; or
- (b) "Bodily injury by disease" is caused by or aggravated by conditions of employment by you and the injured "employee's" last day of last exposure to the conditions causing or aggravating such "bodily injury by disease" occurs during the policy period.

- c. The damages we will pay, where recovery is permitted by law, include damages:

- (1) For:

- (a) Which you are liable to a third party by reason of a claim or "suit" against you by that third party to recover the damages claimed against such third party as a result of injury to your "employee";
- (b) Care and loss of services; and
- (c) Consequential "bodily injury by accident" or "bodily injury by disease" to a spouse, child, parent, brother or sister of the injured "employee";

provided that these damages are the direct consequence of "bodily injury by accident" or "bodily injury by disease" that arises out of and in the course of the injured "employee's" employment by you; and

- (2) Because of "bodily injury by accident" or "bodily injury by disease" to your "employee" that arises out of and in the course of employment, claimed against you in a capacity other than as employer.

## 2. Exclusions

This insurance does not apply to:

- a. **Intentional Injury**

"Bodily injury by accident" or "bodily injury by disease" intentionally caused or aggravated by you, or "bodily injury by accident" or "bodily injury by disease" resulting from an act which is determined to have been committed by you if it was reasonable to believe that an injury is substantially certain to occur.

- b. **Fines Or Penalties**

Any assessment, penalty, or fine levied by any regulatory inspection agency or authority.

- c. **Statutory Obligations**

Any obligation of the insured under a workers' compensation, disability benefits or unemployment compensation law or any similar law.

- d. **Contractual Liability**

Liability assumed by you under any contract or agreement.

- e. **Violation Of Law**

"Bodily injury by accident" or "bodily injury by disease" suffered or caused by any employee while employed in violation of law with your actual knowledge or the actual knowledge of any of your "executive officers".

- f. **Termination, Coercion Or Discrimination**

Damages arising out of coercion, criticism, demotion, evaluation, reassignment, discipline, defamation, harassment, humiliation, discrimination against or termination of any "employee", or arising out of other employment or personnel decisions concerning the insured.

- g. **Failure To Comply With "Workers Compensation Law"**

"Bodily injury by accident" or "bodily injury by disease" to an "employee" when you are:

- (1) Deprived of common law defenses; or

- (2) Otherwise subject to penalty;

because of your failure to secure your obligations or other failure to comply with any "workers compensation law".

- h. **Violation Of Age Laws Or Employment Of Minors**

"Bodily injury by accident" or "bodily injury by disease" suffered or caused by any person:

- (1) Knowingly employed by you in violation of any law as to age; or

- (2) Under the age of 14 years, regardless of any such law.

- i. **Federal Laws**

Any premium, assessment, penalty, fine, benefit, liability or other obligation imposed by or granted pursuant to:

- (1) The Federal Employer's Liability Act (45 USC Section 51-60);

- (2) The Non-appropriated Fund Instrumentalities Act (5 USC Sections 8171-8173);

- (3) The Longshore and Harbor Workers' Compensation Act (33 USC Sections 910-950);

- (4) The Outer Continental Shelf Lands Act (43 USC Section 1331-1356);

- (5) The Defense Base Act (42 USC Sections 1651-1654);

- (6) The Federal Coal Mine Health and Safety Act of 1969 (30 USC Sections 901-942);
- (7) The Migrant and Seasonal Agricultural Worker Protection Act (29 USC Sections 1801-1872);
- (8) Any other workers compensation, unemployment compensation or disability laws or any similar law; or
- (9) Any subsequent amendments to the laws listed above.

**j. Punitive Damages**

Multiple, exemplary or punitive damages.

**k. Crew Members**

"Bodily injury by accident" or "bodily injury by disease" to a master or member of the crew of any vessel or any member of the flying crew of an aircraft.

**B. The Supplementary Payments provisions apply to Coverage - Stop Gap Employers Liability as well as to Coverages A and B.**

**C. For the purposes of this endorsement, Section II - Who Is An Insured, is replaced by the following:**

If you are designated in the Declarations as:

- 1. An individual, you and your spouse are insureds, but only with respect to the conduct of a business of which you are the sole owner.
- 2. A partnership or joint venture, you are an insured. Your members, your partners, and their spouses are also insureds, but only with respect to the conduct of your business.
- 3. A limited liability company, you are an insured. Your members are also insureds, but only with respect to the conduct of your business. Your managers are insureds, but only with respect to their duties as your managers.
- 4. An organization other than a partnership, joint venture or limited liability company, you are an insured. Your "executive officers" and directors are insureds, but only with respect to their duties as your officers or directors. Your stockholders are also insureds, but only with respect to their liability as stockholders.

No person or organization is an insured with respect to the conduct of any current or past partnership, joint venture or limited liability company that is not shown as a Named Insured in the Declarations.

**D. For the purposes of this endorsement, Section III - Limits Of Insurance, is replaced by the following:**

- 1. The Limits of Insurance shown in the Schedule of this endorsement and the rules below fix the most we will pay regardless of the number of:
  - a. Insureds;
  - b. Claims made or "suits" brought; or
  - c. Persons or organizations making claims or bringing "suits".
- 2. The "Bodily Injury By Accident" - Each Accident Limit shown in the Schedule of this endorsement is the most we will pay for all damages covered by this insurance because of "bodily injury by accident" to one or more "employees" in any one accident.
- 3. The "Bodily Injury By Disease" - Aggregate Limit shown in the Schedule of this endorsement is the most we will pay for all damages covered by this insurance and arising out of "bodily injury by disease", regardless of the number of "employees" who sustain "bodily injury by disease".
- 4. Subject to Paragraph D.3. of this endorsement, the "Bodily Injury By Disease" - Each "Employee" Limit shown in the Schedule of this endorsement is the most we will pay for all damages because of "bodily injury by disease" to any one "employee".

The limits of the coverage apply separately to each consecutive annual period and to any remaining period of less than 12 months, starting with the beginning of the policy period shown in the Declarations, unless the policy period is extended after issuance for an additional period of less than 12 months. In that case, the additional period will be deemed part of the last preceding period for purposes of determining the Limits of Insurance.

**E. For the purposes of this endorsement, Condition 2. - Duties In The Event Of Occurrence, Claim Or Suit of the Conditions Section IV is deleted and replaced by the following:**

- 2. **Duties In The Event Of Injury, Claim Or Suit**
  - a. You must see to it that we or our agent are notified as soon as practicable of a "bodily injury by accident" or "bodily injury by disease" which may result in a claim. To the extent possible, notice should include:
    - (1) How, when and where the "bodily injury by accident" or "bodily injury by disease" took place;
    - (2) The names and addresses of any injured persons and witnesses; and

- (3) The nature and location of any injury.
- b. If a claim is made or "suit" is brought against any insured, you must:
- (1) Immediately record the specifics of the claim or "suit" and the date received; and
  - (2) Notify us as soon as practicable.
- You must see to it that we receive written notice of the claim or "suit" as soon as practicable.
- c. You and any other involved insured must:
- (1) Immediately send us copies of any demands, notices, summonses or legal papers received in connection with the injury, claim, proceeding or "suit";
  - (2) Authorize us to obtain records and other information;
  - (3) Cooperate with us and assist us, as we may request, in the investigation or settlement of the claim or defense against the "suit";
  - (4) Assist us, upon our request, in the enforcement of any right against any person or organization which may be liable to the insured because of injury to which this insurance may also apply; and
  - (5) Do nothing after an injury occurs that would interfere with our right to recover from others.
- d. No insured will, except at that insured's own cost, voluntarily make a payment, assume any obligation, or incur any expense, other than for first aid, without our consent.
- F. For the purposes of this endorsement, Paragraph 4. of the **Definitions** Section is replaced by the following:
4. "Coverage territory" means:
- a. The United States of America (including its territories and possessions), Puerto Rico and Canada;
  - b. International waters or airspace, but only if the injury or damage occurs in the course of travel or transportation between any places included in a. above; or
  - c. All other parts of the world if the injury or damage arises out of the activities of a person whose home is in the territory described in a. above, but who is away for a short time on your business;
- provided the insured's responsibility to pay damages is determined in the United States (including its territories and possessions), Puerto Rico, or Canada, in a suit on the merits according to the substantive law in such territory, or in a settlement we agree to.
- G. The following are added to the **Definitions** Section:
1. "Workers Compensation Law" means the Workers Compensation Law and any Occupational Disease Law of Washington. This does not include provisions of any law providing non-occupational disability benefits.
  2. "Bodily injury by accident" means bodily injury, sickness or disease sustained by a person, including death, resulting from an accident. A disease is not "bodily injury by accident" unless it results directly from "bodily injury by accident".
  3. "Bodily injury by disease" means a disease sustained by a person, including death. "Bodily injury by disease" does not include a disease that results directly from an accident.
- H. For the purposes of this endorsement, the definition of "bodily injury" does not apply.

THIS ENDORSEMENT CHANGES THE POLICY. PLEASE READ IT CAREFULLY.

## ADDITIONAL INSURED – SCHEDULED – CONTRACTORS – OPERATIONS AND COMPLETED OPERATIONS

This endorsement modifies insurance provided under the following:

COMMERCIAL GENERAL LIABILITY COVERAGE PART

### SCHEDULE

<b>Name of Person or Organization:</b>	AS REQUIRED BY WRITTEN CONTRACT
<b>Location And Description of Operations:</b>	AS REQUIRED BY WRITTEN CONTRACT
Information required to complete this Schedule, if not shown above, will be shown in the Declarations.	

#### 1. Additional Insured – Operations

##### A. Operations Performed For An Additional Insured

**Section II – Who Is An Insured** is amended to include as an additional insured any person or organization shown in the schedule, but only with respect to liability for “bodily injury”, “property damage” or “personal and advertising injury” arising out of your ongoing operations for the additional insured at the location(s) designated and described in this endorsement.

##### B. Limitations

The Operations Performed for Additional Insured coverage is limited as follows:

- (1) This insurance does not apply to “bodily injury” or “property damage” occurring after:
  - a. All work, including materials, parts or equipment furnished in connection with such work, on the project (other than service, maintenance or repairs) to be performed by or on behalf of the additional insured(s) at the location of the covered operations has been completed; or

- b. That portion of “your work” out of which the injury or damage arises has been put to its intended use by any person or organization other than another contractor or subcontractor engaged in performing operations for a principal as a part of the same project.

#### 2. Additional Insured – Completed Operations

##### A. Additional Insured – Completed Operations

**Section II – Who Is An Insured** is amended to include as an additional insured any person or organization shown in the schedule, but only with respect to “bodily injury” or “property damage”, arising out of “your work” performed for that additional insured at the location(s) designated and described in this endorsement and included in the “products-completed operations hazard”.

##### B. Limitations

The Additional Insured – Completed Operations coverage is limited as follows:

- (1) A person or organization’s status as an insured under Additional Insured – Completed Operations continues only for the period of time required by any written contract or agreement.

- (2) The insurance provided to the additional insured does not apply to “bodily injury”, “property damage” or “personal and advertising injury” arising out of “your work” for which a consolidated (wrap-up) insurance program has been provided by the prime contractor-project manager or owner of the construction project in which you are involved.

### 3. Primary and Noncontributory

The following is added to the **Other Insurance** Condition and supersedes any provision to the contrary:

#### **Primary And Noncontributory Insurance**

This insurance is primary to and will not seek contribution from any other insurance available to an additional insured under your policy provided that:

- (1) The additional insured is a Named Insured under such other insurance; and
- (2) You have agreed in writing in a contract or agreement that this insurance would be primary and would not seek contribution from any other insurance available to the additional insured.

### 4. Other Provisions Applicable to Additional Insured – Operations and Additional Insured – Completed Operations

- A. The Amendment of Insured Contract Definition (Endorsement CG 24 26) does not apply to the person or organization scheduled on this endorsement.
- B. The coverage provided under Paragraph f. of the definition of “insured contract” under **Section V – Definitions** does not apply to an additional insured under this endorsement unless required by a written contract or agreement.
- C. The insurance afforded to such additional insured only applies to the extent permitted by law; and

If coverage provided to the additional insured is required by a contract or agreement, the insurance afforded to such additional insured will not be broader than that which you are required by the contract or agreement to provide for such additional insured.

- D. With respect to the insurance afforded to these additional insureds, the following is added to **Section III – Limits Of Insurance**:

If coverage provided to the additional insured is required by a contract or agreement, the most we will pay on behalf of the additional insured is:

- (1) The minimum amount required by the contract or agreement; or
- (2) The Limits of Insurance shown in the Declarations;

whichever is less.

This endorsement shall not increase the applicable Limits of Insurance shown in the Declarations.

- E. With respect to the insurance afforded to these additional insureds, the following additional exclusion applies:

This insurance does not apply to:

- (1) "Bodily injury", "property damage" or "personal and advertising injury" arising out of the rendering of, or the failure to render, any professional architectural, engineering or surveying services, including:

- a. The preparing, approving, or failing to prepare or approve, maps, shop drawings, opinions, reports, surveys, field orders, change orders or drawings and specifications; or
- b. Supervisory, inspection, architectural or engineering activities.

This exclusion applies even if the claims against an additional insured allege negligence or other wrongdoing in the supervision, hiring, employment, training or monitoring of others by that insured, if the “occurrence” which caused the “bodily injury” or “property damage”, or the offense which caused the “personal and advertising injury”, involved the rendering of or failure to render any professional services by you with respect to your providing engineering, architectural or surveying services in your capacity as an engineer, architect or surveyor.

## BUSINESS AUTO ENHANCEMENT EDGE ENDORSEMENT

The Business Auto Enhancement Edge Endorsement is an optional endorsement that provides coverage enhancements. The following is a summary of broadened coverages provided by this endorsement. No coverage is provided by this summary, refer to the following endorsement for changes in your policy.

<b>SUMMARY OF COVERAGES</b>	<b>PAGE</b>
Accidental Airbag Deployment Coverage	5
Audio, Visual and Data Electronic Equipment – Limit Amended	5
Auto Loan/Lease Gap Coverage	5
Blanket Additional Insured	3
Blanket Waiver of Subrogation	5
Broadened Definition of Insured includes:	
• Newly Acquired Organizations for up to 180 Days	2
• Employees as Insureds	2
• Subsidiaries in Which You Own 50% or More	2
Deductible Waiver for Glass Repair	4
Employee Hired Auto	6
Fellow Employee Coverage	3
Hired Auto Physical Damage Coverage	3, 6
Knowledge of Accident, Claim, Suit or Loss	5
Loss Of Use Expenses - Amended	3
Personal Effects	3
Primary and Noncontributory If Required by a Written Contract or Written Agreement	6
Rental Reimbursement Coverage	4
Supplementary Payments - Amended:	
• Bail Bonds up to \$5,000	3
• Loss of Earnings up to \$500/Day	3
Temporary Substitute Vehicle Physical Damage	2
Towing	3
Transportation Expense Limits – Amended	3
Unintentional Failure to Disclose Hazards	6



**THIS ENDORSEMENT CHANGES THE POLICY. PLEASE READ IT CAREFULLY.**

## **BUSINESS AUTO ENHANCEMENT EDGE ENDORSEMENT**

This endorsement modifies the insurance provided under the following:

### **BUSINESS AUTO COVERAGE FORM**

With respect to the coverage provided by this endorsement, the provisions of the Coverage Form apply unless modified by this endorsement. The SECTIONS of the Business Auto Coverage Form identified in this endorsement will be amended as shown below.

#### **SECTION I – COVERED AUTOS COVERAGE AMENDMENTS**

##### **A. Temporary Substitute Vehicle Physical Damage**

**SECTION I – COVERED AUTOS, C. Certain Trailers, Mobile Equipment And Temporary Substitute Autos** is amended by adding the following:

If a covered “auto” you own is out of service because of its:

- a. Breakdown;
- b. Repair;
- c. Servicing;
- d. “Loss”, or
- e. Destruction;

the Physical Damage Coverages provided by the Business Auto Coverage Form for that disabled covered “auto” are extended to any “auto” you do not own while used with the permission of its owner as a temporary substitute for the covered “auto” that is out of service.

#### **SECTION II – COVERED AUTOS LIABILITY COVERAGE AMENDMENTS**

##### **A. Who Is An Insured**

**SECTION II – COVERED AUTOS LIABILITY COVERAGE, A. Coverage, 1. Who Is An Insured** is amended to add:

- d. Any legally incorporated subsidiary of yours in which you own more than 50% of the voting stock on the effective date of this coverage form.

However, “insured” does not include any subsidiary of yours that is an “insured” under any other automobile liability policy or would be an “insured” under such policy but for termination of such policy or the exhaustion on such policy’s limits of insurance.

- e. Any organization which is newly acquired or formed by you and over which you maintain majority ownership. However, coverage under this provision:

- (1) is afforded only for the first 180 days after you acquire or form the organization or until the end of the policy period, whichever comes first;
- (2) does not apply to “bodily injury” or “property damage” that results from an “accident” that occurred before you formed or acquired the organization;
- (3) does not apply to any newly acquired or formed organization that is a joint venture or partnership; and
- (4) does not apply to an “insured” under any other automobile liability policy or would be an “insured” under such a policy but for termination of such policy or the exhaustion of such policy’s limits of insurance.

- f. Any “employee” of yours is an “insured” while using a covered “auto” you don’t own, hire or borrow in your business or your personal affairs.

- g. Any “employee” of yours is an “insured” while operating a covered “auto” hired or rented under a contract or agreement in the “employee’s” name, with your permission, while performing duties related to the conduct of your business.

**B. Blanket Additional Insured**

**SECTION II – COVERED AUTOS LIABILITY COVERAGE, A. Coverage, 1. Who Is An Insured, paragraph c.** is amended to add the following:

Any person or organization who is required under a written contract or agreement between you and that person or organization, that is signed and executed by you before the “bodily injury” or “property damage” occurs and that is in effect during the policy period, to be named as an additional insured is an “insured” for Liability Coverage, but only for damages to which this insurance applies and only to the extent that persons or organization qualifies as an “insured” under the Who Is An Insured provision contained in Section II.

**C. Liability Coverage Extensions – Supplementary Payments**

**SECTION II – COVERED AUTOS LIABILITY COVERAGE, A. Coverage, 2. Coverage Extensions, a. Supplementary Payments** is amended by replacing subparagraphs (2) and (4) with the following:

- (2) Up to \$5,000 for cost of bail bonds (including bonds for related traffic law violations) required because of an “accident” we cover. We do not have to furnish these bonds.
- (4) All reasonable expenses incurred by the “insured” at our request, including actual loss of earnings up to \$500 a day because of time off from work.

**D. Fellow Employee Coverage**

**SECTION II – COVERED AUTOS LIABILITY COVERAGE, B. Exclusions, 5. Fellow Employee,** the following is added:

<b>Co-Employee</b>	<b>Lawsuit</b>	<b>Defense</b>	<b>Cost</b>
<b>Reimbursement</b>			

If a suit seeking damages for “bodily injury” to any fellow “employee” of the “insured” arising out of and in the course of the fellow “employee’s” employment or while performing duties related to the conduct of your business, or a suit seeking damages brought by the spouse, child, parent, brother or sister of that fellow “employee”, is brought against you, we will reimburse reasonable costs that you incur in the defense of such matters. Any reimbursement made pursuant to this sub-section will be in addition to the limits of liability set forth in the Declarations.

**SECTION III – PHYSICAL DAMAGE COVERAGE AMENDMENTS**

**A. Towing**

**SECTION III – PHYSICAL DAMAGE COVERAGE, A. Coverage, 2. Towing,** is amended by adding the following:

**2. Towing**

We will pay up to \$250 for towing and labor costs incurred each time a covered “auto” is disabled. However, the labor must be performed at the place of disablement. This \$250 limit is reduced by any applicable towing limit shown in the declarations.

Regardless of the number of disablements, the maximum amount we will pay under this endorsement for all towing and labor costs combined during any one year is \$2,500.

**B. Transportation Expense – Limits Amended**

**SECTION III – PHYSICAL DAMAGE COVERAGE, A. Coverage, 4. Coverage Extensions, a. Transportation Expenses** is amended by replacing \$20 per day/\$600 maximum limit with \$50 per day/\$1,000 maximum.

**C. Hired Auto Physical Damage – Loss Of Use Expenses – Limits Amended**

**SECTION III – PHYSICAL DAMAGE COVERAGE, A. Coverage, 4. Coverage Extensions, b. Loss of Use Expenses** is amended by replacing the \$20 per day/\$600 maximum limit with \$50 per day/\$750 maximum limit.

**D. Personal Effects Coverage**

**SECTION III – PHYSICAL DAMAGE COVERAGE, A. Coverage, 4. Coverage Extensions** is amended by adding the following:

**c. Personal Effects**

We will pay up to \$500 for “loss” to personal effects, which are:

- (1) Owned by an “insured”; and
- (2) In or on your covered “auto.”

This coverage applies only in the event of the total theft of your covered “auto.” No deductible applies to this coverage

**E. Glass Repair – Deductible Waiver**

**SECTION III – PHYSICAL DAMAGE COVERAGE, A. Coverage, 3. Glass Breakage – Hitting A Bird Or Animal – Falling Objects Or Missiles,** is amended by adding the following:

No deductible will apply to glass breakage if such glass is repaired, in a manner acceptable to us, rather than replaced.

**F. Hired Auto Physical Damage**

**SECTION III – PHYSICAL DAMAGE COVERAGE, A. Coverage** is amended by adding the following:

**5. Hired Auto Physical Damage**

If hired “autos” are covered “autos” for Liability Coverage and if Comprehensive, Specified Causes of Loss, or Collision coverages are provided under this coverage form for any “auto” you own, then the Physical Damage Coverages provided are extended to “autos” you hire of like kind and use, subject to the following:

- a. The most we will pay for any one “loss” is \$50,000 or the actual cash value or cost to repair or replace, whichever is less, minus a deductible;
- b. The deductible will be equal to the largest deductible applicable to any owned “auto” for that coverage. Any Comprehensive deductible does not apply to “loss” caused by fire or lightning;
- c. Hired Auto Physical Damage coverage is excess over any other collectible insurance; and
- d. Subject to the above limit, deductible and excess provisions we will provide coverage equal to the broadest coverage applicable to any covered “auto” you own.

If a limit for Hired Auto Physical Damage is indicated in the Declarations, then that limit replaces, and is not added to, the \$50,000 limit indicated above.

**G. Rental Reimbursement**

**SECTION III – PHYSICAL DAMAGE COVERAGE A. Coverage,** is amended by adding the following:

**6. Rental Reimbursement**

This coverage applies only to a covered “auto” of the private passenger or light truck type as follows:

- a. We will pay for rental reimbursement expenses incurred by you for the rental of a private passenger or light truck type “auto” because of “loss” to a covered private passenger or light truck type “auto”. Payment applies in addition to the otherwise applicable amount of each coverage you have on a covered private passenger or light truck type “auto.” No deductibles apply to this coverage.
- b. We will pay only for those expenses incurred during the policy period beginning 24 hours after the “loss” and ending, regardless of the policy’s expiration, with the lesser of the following number of days:
  - (1) The number of days reasonably required to repair or replace the covered private passenger or light truck type “auto”. If “loss” is caused by theft, this number of days is added to the number of days it takes to locate the covered private passenger or light truck type “auto” and return it to you; or
  - (2) 30 days.
- c. Our payment is limited to the lesser of the following amounts:
  - (1) Necessary and actual expenses incurred, or
  - (2) \$50 per day, up to a maximum of \$1,000.

- d. This coverage does not apply while there are spare or reserve private passenger or light truck type “autos” available to you for your operations.
- e. If “loss” results from the total theft of a covered “auto” of the private passenger or light truck type, we will pay under this coverage only that amount of your rental reimbursement expenses which is not already provided for under **SECTION III – PHYSICAL DAMAGE COVERAGE, A. Coverage, 4. Coverage Extensions.**

For the purposes of this Rental Reimbursement coverage, light truck is defined as a truck with a gross vehicle weight of 10,000 lbs. or less as defined by the manufacturer as the maximum loaded weight the auto is designed to carry.

**H. Accidental Airbag Deployment Coverage**

**SECTION III – PHYSICAL DAMAGE COVERAGE, A. Coverage** is amended by adding the following:

**7. Accidental Airbag Deployment Coverage**

We will pay to reset or replace factory installed airbag(s) in any covered “auto” for accidental discharge, other than discharge due to a collision loss.

This coverage is applicable only if comprehensive coverage applies to the covered “auto”.

This coverage is excess over any other collectible insurance or reimbursement by manufacturer’s warranty.

**I. Auto Loan/Lease Gap Coverage**

**SECTION III PHYSICAL DAMAGE COVERAGE, Item A., Coverage,** is amended by adding the following:

**8. Auto Loan/Lease Gap Coverage**

This coverage applies only to a covered “auto” described or designated in the Schedule or in the Declarations as including physical damage coverage.

In the event of a covered total “loss” to a covered “auto” described or designated in the Schedule or in the Declarations, we will pay any unpaid amount due on the lease or loan for a covered “auto” less:

- a. The amount paid under the Physical Damage Coverage Section on the policy; and
- b. Any:
  - (1) Overdue lease/loan payments at the time of the “loss”;

- (2) Financial penalties imposed under a lease for excessive use, abnormal wear and tear or high mileage;
- (3) Security deposits not returned by the lessor;
- (4) Costs for extended warranties, Credit Life Insurance, Health, Accident or Disability Insurance purchased with the loan or lease; and
- (5) Carry-over balances from previous loans or leases.

**J. Audio, Visual and Data Electronic Equipment – Limit Amended**

**SECTION III - PHYSICAL DAMAGE COVERAGE, C. Limits of Insurance, 1.b.** is amended by replacing the \$1,000 limit with a \$2,500 limit.

**SECTION IV – BUSINESS AUTO CONDITIONS AMENDMENTS**

**A. Duties In The Event Of Accident, Claim, Suit Or Loss Amended**

**SECTION IV – BUSINESS AUTO CONDITIONS, A. Loss Conditions, 2. Duties In The Event Of Accident, Claim, Suit Or Loss, a.** is amended by adding the following:

This condition applies only when the “accident” or “loss” is known to:

- (1) You, if you are an individual;
- (2) A partner, if you are a partnership;
- (3) An executive officer or insurance manager, if you are a corporation; or
- (4) A member or manager, if you are a limited liability company.

But this section does not amend the provisions relating to notification of police, protection or examination of the property which was subject to the “loss”.

**B. Blanket Waiver of Subrogation**

**Section IV – BUSINESS AUTO CONDITIONS, A. Loss Conditions, 5. Transfer of Rights of Recovery Against Others to Us,** is amended by adding the following exception:

However, we waive any right of recovery we may have against any person or organization to the extent required of you by a written contract signed and executed prior to any “accident” or “loss”, provided that the “accident” or “loss” arises out of operations contemplated by such contract. The waiver applies only to the person or organization designated in such contract.

**C. Unintentional Failure to Disclose Hazards**

**SECTION IV – BUSINESS AUTO CONDITIONS, B. General Conditions, 2. Concealment, Misrepresentation Or Fraud**, is amended by adding the following paragraph:

If you unintentionally fail to disclose any hazards existing at the inception date of the policy, or during the policy period in connection with any additional hazards, we will not deny coverage under this Coverage Part because of such failure.

**D. Employee Hired Auto**

**SECTION IV – BUSINESS AUTO CONDITIONS, B. General Conditions, 5. Other Insurance**, paragraph b. is deleted and replaced by the following:

- b. For Hired Auto Physical Damage Coverage, the following are deemed to be a covered “auto” you own:
- (1) Any covered “auto” you lease, hire, rent or borrow.
  - (2) Any covered “auto” hired or rented by your “employee” under a contract in that individual “employee’s” name, with your permission, while performing duties related to the conduct of your business.

However, any “auto” that is leased, hired, rented or borrowed with a driver is not a covered “auto”.

**E. Primary and Noncontributory If Required By Written Contract or Written Agreement**

**SECTION IV – BUSINESS AUTO CONDITIONS, B. General Conditions, 5. Other Insurance c.**, the following is added and supersedes any provision to the contrary:

This Coverage Form’s Covered Autos Liability Coverage is primary to and will not seek contribution from any other insurance available to an “insured” under your policy provided that:

- (1) Such “insured” is a Named Insured under such other insurance; and
- (2) You have agreed in writing in a contract or agreement that this insurance would be primary and would not seek contribution from any other insurance available to such “insured”.

## COMMERCIAL GENERAL LIABILITY ENHANCEMENT ENDORSEMENT

The Commercial General Liability Enhancement Endorsement is an optional endorsement that provides coverage enhancements. The following is a summary of broadened coverages provided by this endorsement. No coverage is provided by this summary, refer to following endorsement for changes in your policy.

<b>SUMMARY OF COVERAGES</b>	<b>PAGE</b>
Bodily Injury And Property Damage Liability	
• Non Owned Watercraft Up To 50 Feet.....	2
Property Damage Liability	
• Elevators.....	3
• Fire, Lightning, Explosion Or Sprinkler Leakage Exception .....	3
• Borrowed Equipment (\$25,000 Per Occurrence, \$50,000 Aggregate, \$2,500 Deductible Per Occurrence .....	3
Supplementary Payments – Amended	
• Bail Bonds Up To \$5,000.....	3
• Loss of Earnings Up To \$500/Day .....	3
Who Is An Insured Amendments	
• Employee Bodily Injury To A Co-Employee .....	4
• Newly Formed Or Acquired Organizations For Up To 180 Days .....	4
• Blanket Additional Insured – Vendors – As Required By Contract .....	4
• Blanket Additional Insured – Lessor Of Leased Equipment .....	6
• Blanket Additional Insured – Managers Or Lessors Of Premises .....	6
• Blanket Additional Insured – State Or Governmental Agency Or Subdivision Or Political Subdivision – Permits Or Authorizations .....	7
• Blanket Additional Insured – State Or Governmental Agency Or Subdivision Or Political Subdivision – Permits Or Authorizations Relating To Premises .....	8
Damage To Premises Rented To You – \$300,000.....	9
Medical Payments Increased Limit – \$10,000 Or Amount Shown on Declarations .....	9
Conditions	
• Knowledge of Occurrence, Offense, Claim Or Suit Amended .....	9
• Unintentional Failure To Disclose Hazards .....	9
• Waiver of Subrogation .....	10
Insured Contract Amended .....	10
Personal And Advertising Injury Redefined	
• Televised, Videotaped Or Electronic Publication .....	10

**THIS ENDORSEMENT CHANGES THE POLICY. PLEASE READ IT CAREFULLY**

**COMMERCIAL GENERAL LIABILITY ENHANCEMENT ENDORSEMENT**

This endorsement modifies the insurance provided under the following:

COMMERCIAL GENERAL LIABILITY COVERAGE FORM

With respect to the coverage provided by this endorsement, the provisions of the Coverage Form apply unless modified by this endorsement. The SECTIONS of the Commercial General Liability Coverage Form identified in this endorsement will be amended as shown below.

**SECTION I – COVERAGES AMENDMENTS**

**COVERAGE A – BODILY INJURY AND PROPERTY DAMAGE LIABILITY**

**A. Non Owned Aircraft Or Watercraft**

Item 2. Exclusions, Paragraph g. is replaced by the following:

**g. Aircraft, Auto Or Watercraft**

“Bodily injury” or “property damage” arising out of the ownership, maintenance, use or entrustment to others of any aircraft, “auto” or watercraft owned or operated by or rented or loaned to any insured. Use includes operation and “loading or unloading”.

This exclusion applies even if the claims against any insured allege negligence or other wrongdoing in the supervision, hiring, employment, training or monitoring of others by that insured, if the “occurrence” which caused the “bodily injury” or “property damage” involved in the ownership, maintenance, use or entrustment to others of any aircraft, “auto” or watercraft that is owned or operated by or rented or loaned to any insured.

This exclusion does not apply to:

- (1) A watercraft while ashore on premises you own or rent;
- (2) A watercraft you do not own that is:
  - (a) Less than 50 feet long; and
  - (b) Not being used to carry persons or property for a charge;

This Subparagraph (2) applies to any person, who with your expressed or implied consent, either uses or is responsible for the use of the watercraft;

- (3) Parking an “auto” on, or on the ways next to, premises you own or rent, provided the “auto” is not owned by or rented or loaned to you or the insured;
- (4) Liability assumed under any “insured contract” for the ownership, maintenance or use of aircraft or watercraft; or
- (5) “Bodily injury” or “property damage” arising out of:
  - (a) The operation of machinery or equipment that is attached to, or part of, a land vehicle that would qualify under the definition of “mobile equipment” if it were not subject to a compulsory or financial responsibility law or other motor vehicle insurance law where it is licensed or principally garaged; or
  - (b) The operation of any of the machinery or equipment listed in Paragraph f. (2) or f. (3) of the definition of “mobile equipment”.

## B. Damage To Property Coverage Extensions

Item 2. **Exclusions**, Paragraph j. is replaced by the following:

### j. Damage To Property

“Property damage” to:

- (1) Property you own, rent, or occupy, including any costs or expenses incurred by you, or any other person, organization or entity, for repair, replacement, enhancement, restoration or maintenance of such property for any reason, including prevention of injury to a person or damage to another’s property;
- (2) Premises you sell, give away or abandon, if the “property damage” arises out of any part of those premises;
- (3) Property loaned to you;
- (4) Personal property in the care, custody or control of the insured;
- (5) That particular part of real property on which you or any contractors or subcontractors working directly or indirectly on your behalf are performing operations, if the “property damage” arises out of those operations; or
- (6) That particular part of any property that must be restored, repaired or replaced because “your work” was incorrectly performed on it.

Paragraphs (1), (3) and (4) of this exclusion do not apply to “property damage” (other than damage by fire, lightning, explosion or sprinkler leakage) to premises, including the contents of such premises, rented to you for a period of seven or fewer consecutive days. A separate limit of insurance applies to Damage To Premises Rented To You as described in **SECTION III – LIMITS OF INSURANCE**. However, the provisions of this paragraph do not apply if coverage for Damage To Premises Rented To You is excluded by endorsement.

Paragraph (2) of this exclusion does not apply if the premises are “your work” and were never occupied, rented or held for rental by you.

Paragraphs (3) and (4) of this exclusion do not apply to the use of elevators.

Paragraphs (3), (4), (5) and (6) of this exclusion do not apply to liability assumed under a sidetrack agreement.

Paragraph (4) of this exclusion does not apply to “property damage” to borrowed equipment while not being used to perform operations at the jobsite. Subject to Paragraph 2. of **SECTION III – LIMITS OF INSURANCE**, the rules below fix the most we will pay for “property damage” under this provision:

- (1) \$25,000 any one “occurrence”, regardless of the number of persons or organizations who sustain damages because of that “occurrence”;
- (2) \$50,000 annual aggregate; and
- (3) We will pay only for damages in excess of \$2,500 as a result of any one “occurrence”, regardless of the number of persons or organizations who sustain damages because of that “occurrence”. We may, or if required by law, pay all or any part of any deductible amount, if applicable, to effect settlement of any claim or “suit”. Upon notice of our payment of a deductible amount, you shall promptly reimburse us for the part of the deductible amount we paid.

Paragraph (6) of this exclusion does not apply to “property damage” included in the “products-completed operations hazard”.

The insurance provided for “property damage” from the use of elevators and for “property damage” to borrowed equipment is excess over any other valid and collectible property insurance (including any deductible portion thereof) available to the insured whether primary, excess, contingent or on any other basis.

## C. Damage To Premises Rented To You

Item 2. **Exclusions**, the last paragraph is replaced by the following:

Exclusions c. through n. do not apply to damage by fire, lightning, explosion or sprinkler leakage to premises while rented to you or temporarily occupied by you with permission of the owner. A separate limit of insurance applies to this coverage as described in Paragraph 6. of **SECTION III – LIMITS OF INSURANCE**.



## COVERAGE B – PERSONAL AND ADVERTISING INJURY LIABILITY

### D. Personal And Advertising Injury

Item 2. **Exclusions** is amended by replacing Sub-paragraphs **b.** and **c.** with the following:

#### b. Material Published With Knowledge Of Falsity

“Personal and advertising injury” arising out of oral, written, televised, videotaped or electronic publication, in any manner, of material, if done by or at the direction of the insured with knowledge of its falsity.

#### c. Material Published Prior To Policy Period

“Personal and advertising injury” arising out of oral, written, televised, videotaped or electronic publication, in any manner, of material whose first publication took place before the beginning of the policy period.

## SUPPLEMENTARY PAYMENTS – COVERAGES A AND B

### E. Supplementary Payments – Coverages A and B

Item 1. is amended by replacing Subparagraphs **b.** and **d.** with the following:

- b.** Up to \$5,000 for cost of bail bonds required because of accidents or traffic law violations arising out of the use of any vehicle to which the Bodily Injury Liability Coverage applies. We do not have to furnish these bonds.
- d.** All reasonable expenses incurred by the insured at our request to assist us in the investigation or defense of the claim or “suit”, including actual loss of earnings up to \$500 a day because of time off from work.

## SECTION II – WHO IS AN INSURED AMENDMENTS

### A. Employee Bodily Injury To A Co-Employee

Paragraph 2. **a. (1)** is replaced by the following:

However, none of these “employees” or “volunteer workers” are insureds for “bodily injury” or “personal and advertising injury”:

- (a)** To you, to your partners or members (if you are a partnership or joint venture), to your members (if you are a limited liability company), to a co-“employee” while in the course of his or her employment or performing duties related to the conduct of your business, or to your other “volunteer workers” while performing duties related to the conduct of your business;
- (b)** To the spouse, child, parent, brother or sister of the co-“employee” or “volunteer worker” as a consequence of Paragraph **(1)(a)** above;
- (c)** For which there is any obligation to share damages with or repay someone else who must pay damages because of the injury described in Paragraph **(1)(a)** or **(b)** above; or
- (d)** Arising out of his or her providing or failing to provide professional health care services.

However, if a suit seeking damages for “bodily injury” or “personal and advertising injury” to any co-“employee” or other “volunteer worker” arising out of and in the course of the co-“employee’s” or “volunteer worker’s” employment or while performing duties related to the conduct of your business, or a suit seeking damages brought by the spouse, child, parent, brother or sister of the co-“employee” or other “volunteer worker”, is brought against you or a co-“employee” or a “volunteer worker”, we will reimburse the reasonable costs that you incur in providing a defense to the co-“employee” or “volunteer worker” against such matters. Any reimbursement made pursuant to this sub-section will be in addition to the limits of liability set forth in the Declarations.

### B. Newly Acquired Organizations

Paragraph 3. **a.** is replaced by the following:

- a.** Coverage under this provision is afforded only until the 180<sup>th</sup> day after you acquire or form the organization or the end of the policy period, whichever is earlier;

The following are added:

**C. Blanket Additional Insured – Vendors – As Required By Contract**

1. **Section II – Who Is An Insured** is amended to include as an additional insured any person(s) or organization(s) (referred to throughout this endorsement as vendor) with whom you have agreed in a written contract, executed prior to loss, to name as an additional insured, but only with respect to "bodily injury" or "property damage" arising out of "your products" which are distributed or sold in the regular course of the vendor's business.

However,

- a. The insurance afforded to such vendor only applies to the extent permitted by law; and
  - b. If coverage provided to the vendor is required by a contract or agreement, the insurance afforded to such vendor will not be broader than that which you are required by the contract or agreement to provide for such vendor.
2. With respect to the insurance afforded to these vendors, the following additional exclusions apply:
- a. The insurance afforded the vendor does not apply to:
    - (1) "Bodily injury" or "property damage" for which the vendor is obligated to pay damages by reason of the assumption of liability in a contract or agreement. This exclusion does not apply to liability for damages that the vendor would have in the absence of the contract or agreement;
    - (2) Any express warranty unauthorized by you;
    - (3) Any physical or chemical change in the product made intentionally by the vendor;
    - (4) Repackaging, except when unpacked solely for the purpose of inspection, demonstration, testing, or the substitution of parts under instructions from the manufacturer, and then repackaged in the original container;
    - (5) Any failure to make such inspections, adjustments, tests or servicing as the vendor has agreed to make or normally undertakes to make in the usual course of business, in connection with the distribution or sale of the products;
    - (6) Demonstration, installation, servicing or repair operations, except such operations performed at the vendor's premises in connection with the sale of the product;
    - (7) Products which, after distribution or sale by you, have been labeled or relabeled or used as a container, part or ingredient of any other thing or substance by or for the vendor; or
    - (8) "Bodily injury" or "property damage" arising out of the sole negligence of the vendor for its own acts or omissions or those of its employees or anyone else acting on its behalf. However, this exclusion does not apply to:
      - (i) The exceptions contained in Subparagraphs (4) or (6); or
      - (ii) Such inspections, adjustments, tests or servicing as the vendor has agreed to make or normally undertakes to make in the usual course of business, in connection with the distribution or sale of the products.
3. This Provision **C.** does not apply:
- a. To any insured person or organization from whom you have acquired such products, or any ingredient, part or container, entering into, accompanying or containing such products;
  - b. To any vendor for which coverage as an additional insured specifically is scheduled by endorsement; or
  - c. When liability included within the "products-completed operations hazard" has been excluded for such product either by the provisions of the coverage part or by endorsement.
4. With respect to the insurance afforded to these vendors, the following is added to **Section III – Limits Of Insurance**:
- If coverage provided to the vendor is required by a contract or agreement, the most we will pay on behalf of the vendor is:
- a. The minimum amount required by the contract or agreement; or
  - b. The Limits of Insurance shown in the Declarations;

whichever is less.

This endorsement shall not increase the applicable Limits of Insurance shown in the Declarations.

5. With respect to the insurance afforded to these additional insureds, the following additional exclusion applies:

This insurance does not apply to:

- a. "Bodily injury", "property damage" or "personal and advertising injury" arising out of the rendering of, or the failure to render, any professional architectural, engineering or surveying services, including:

- (1) The preparing, approving, or failing to prepare or approve, maps, shop drawings, opinions, reports, surveys, field orders, change orders or drawings and specifications; or
- (2) Supervisory, inspection, architectural or engineering activities.

This exclusion applies even if the claims against an additional insured allege negligence or other wrongdoing in the supervision, hiring, employment, training or monitoring of others by that insured, if the "occurrence" which caused the "bodily injury" or "property damage", or the offense which caused the "personal and advertising injury", involved the rendering of or failure to render any professional services by you with respect to your providing engineering, architectural or surveying services in your capacity as an engineer, architect or surveyor.

#### **D. Blanket Additional Insured – Lessor Of Leased Equipment**

1. **Section II – Who Is An Insured** is amended to include as an additional insured any person(s) or organization(s) from whom you lease equipment when you and such person(s) or organization(s) have agreed in writing in a contract or agreement, executed prior to loss, that such person(s) or organization(s) be added as an additional insured on your policy. Such person(s) or organization(s) is an insured only with respect to liability for "bodily injury", "property damage" or "personal and advertising injury" caused by your negligent acts or omissions in the maintenance, operation or use of equipment leased to you by such person(s) or organization(s).

However, the insurance afforded to such additional insured:

- a. Only applies to the extent permitted by law; and
- b. Will not be broader than that which you are required by the contract or agreement to provide for such additional insured.
- c. Does not apply to any "occurrence" which takes place after the equipment lease expires;

A person's or organization's status as an additional insured under this endorsement ends when their contract or agreement with you for such leased equipment ends.

2. With respect to the insurance afforded to the Lessor, the following additional exclusions apply: "Bodily injury" or "property damage" arising out of:
- (1) The assumption of liability in a contract or agreement. This exclusion does not apply to liability for damages that the Lessor would have in the absence of the contract or agreement;
  - (2) Any express warranty made by the Lessor;
  - (3) The demonstration, installation, servicing, inspections, adjustments, tests, repair, or maintenance operations by or for the Lessor;
  - (4) The negligence or strict liability of the Lessor for its own acts or omissions or those of its employees or anyone else acting on its behalf; or
  - (5) Any failure on the part of the Lessor to provide information, instructions and/or warnings with respect to the maintenance, use or operation of the equipment.
3. With respect to the insurance afforded to these additional insureds, the following is added to **Section III – Limits Of Insurance**:

If coverage provided to the additional insured is required by a contract or agreement, the most we will pay on behalf of the additional insured is:

- a. The minimum amount required by the contract or agreement; or
- b. The Limits of Insurance shown in the Declarations;

whichever is less.

This endorsement shall not increase the applicable Limits of Insurance shown in the Declarations.

4. With respect to the insurance afforded to these additional insureds, the following additional exclusion applies:

This insurance does not apply to:

- a. "Bodily injury", "property damage" or "personal and advertising injury" arising out of the rendering of, or the failure to render, any professional architectural, engineering or surveying services, including:

(1) The preparing, approving, or failing to prepare or approve, maps, shop drawings, opinions, reports, surveys, field orders, change orders or drawings and specifications; or

(2) Supervisory, inspection, architectural or engineering activities.

This exclusion applies even if the claims against an additional insured allege negligence or other wrongdoing in the supervision, hiring, employment, training or monitoring of others by that insured, if the "occurrence" which caused the "bodily injury" or "property damage", or the offense which caused the "personal and advertising injury", involved the rendering of or failure to render any professional services by you with respect to your providing engineering, architectural or surveying services in your capacity as an engineer, architect or surveyor.

#### **E. Blanket Additional Insured – Managers Or Lessors Of Premises**

1. **Section II – Who Is An Insured** is amended to include as an additional insured any person(s) or organization(s) with whom you have agreed in a written contract, executed prior to loss, to name as an additional insured, but only with respect to liability arising out of the ownership, maintenance or use of that part of the premises leased to you, subject to the following additional exclusions:

This insurance does not apply to:

- a. Any "occurrence" which takes place after you cease to be a tenant in that premises.
- b. Structural alterations, new construction or demolition operations performed by or on behalf of such additional insured.

However:

- a. The insurance afforded to such additional insured only applies to the extent permitted by law; and
- b. If coverage provided to the additional insured is required by a contract or agreement, the insurance afforded to such additional insured will not be broader than that which you are required by the contract or agreement to provide for such additional insured.

2. With respect to the insurance afforded to these additional insureds, the following is added to **Section III – Limits Of Insurance**:

If coverage provided to the additional insured is required by a contract or agreement, the most we will pay on behalf of the additional insured is:

- a. The minimum amount required by the contract or agreement; or
- b. The Limits of Insurance shown in the Declarations;

whichever is less.

This endorsement shall not increase the applicable Limits of Insurance shown in the Declarations.

3. With respect to the insurance afforded to these additional insureds, the following additional exclusion applies:

This insurance does not apply to:

- a. "Bodily injury", "property damage" or "personal and advertising injury" arising out of the rendering of, or the failure to render, any professional architectural, engineering or surveying services, including:

(1) The preparing, approving, or failing to prepare or approve, maps, shop drawings, opinions, reports, surveys, field orders, change orders or drawings and specifications; or

(2) Supervisory, inspection, architectural or engineering activities.

This exclusion applies even if the claims against an additional insured allege negligence or other wrongdoing in the supervision, hiring, employment, training or monitoring of others by that insured, if the "occurrence" which caused the "bodily injury" or "property damage", or the offense which caused the "personal and advertising injury", involved the rendering of or failure to render any professional services by you with respect to your providing engineering, architectural or surveying services in your capacity as an engineer, architect or surveyor.

**F. Blanket Additional Insured – State Or Governmental Agency Or Subdivision Or Political Subdivision – Permits Or Authorizations**

**Section II – Who Is An Insured** is amended to include as an additional insured any state or governmental agency or subdivision or political subdivision with whom you have agreed in a written contract, executed prior to loss, to name as an additional insured, subject to the following provisions:

1. This insurance applies only with respect to operations performed by you or on your behalf for which the state or governmental agency or subdivision or political subdivision has issued a permit or authorization.

However:

- a. The insurance afforded to such additional insured only applies to the extent permitted by law; and
- b. If coverage provided to the additional insured is required by a contract or agreement, the insurance afforded to such additional insured will not be broader than that which you are required by the contract or agreement to provide for such additional insured.

2. This insurance does not apply to:

- a. "Bodily injury", "property damage" or "personal and advertising injury" arising out of operations performed for the federal government, state or municipality; or
- b. "Bodily injury" or "property damage" included within the "products-completed operations hazard".

3. With respect to the insurance afforded to these additional insureds, the following is added to **Section III – Limits Of Insurance**:

If coverage provided to the additional insured is required by a contract or agreement, the most we will pay on behalf of the additional insured is:

- a. The minimum amount required by the contract or agreement; or
- b. The Limits of Insurance shown in the Declarations;

whichever is less.

This endorsement shall not increase the applicable Limits of Insurance shown in the Declarations.

4. With respect to the insurance afforded to these additional insureds, the following additional exclusion applies:

This insurance does not apply to:

- a. "Bodily injury", "property damage" or "personal and advertising injury" arising out of the rendering of, or the failure to render, any professional architectural, engineering or surveying services, including:
  - (1) The preparing, approving, or failing to prepare or approve, maps, shop drawings, opinions, reports, surveys, field orders, change orders or drawings and specifications; or
  - (2) Supervisory, inspection, architectural or engineering activities.

This exclusion applies even if the claims against an additional insured allege negligence or other wrongdoing in the supervision, hiring, employment, training or monitoring of others by that insured, if the "occurrence" which caused the "bodily injury" or "property damage", or the offense which caused the "personal and advertising injury", involved the rendering of or failure to render any professional services by you with respect to your providing engineering, architectural or surveying services in your capacity as an engineer, architect or surveyor.

**G. Blanket Additional Insured – State Or Governmental Agency Or Subdivision Or Political Subdivision – Permits Or Authorizations Relating To Premises**

**Section II – Who Is An Insured** is amended to include as an additional insured any state or governmental agency or subdivision or political subdivision with whom you have agreed in a written contract, executed prior to loss, to name as an additional insured, subject to the following provision:

1. This insurance applies only with respect to the following hazards for which the state or governmental agency or subdivision or political subdivision has issued a permit or authorization in connection with premises you own, rent or control and to which this insurance applies:

- a. The existence, maintenance, repair, construction, erection or removal of advertising signs, awnings, canopies, cellar entrances, coal holes, driveways, manholes, marquees, hoist away openings, sidewalk vaults, street banners or decorations and similar exposures; or
- b. The construction, erection or removal of elevators; or

c. The ownership, maintenance or use of any elevators covered by this insurance.

However,

- a. The insurance afforded to such additional insured only applies to the extent permitted by law; and
- b. If coverage provided to the additional insured is required by a contract or agreement, the insurance afforded to such additional insured will not be broader than that which you are required by the contract or agreement to provide for such additional insured.

2. With respect to the insurance afforded to these additional insureds, the following is added to **Section III – Limits Of Insurance**:

If coverage provided to the additional insured is required by a contract or agreement, the most we will pay on behalf of the additional insured is:

- a. The minimum amount required by the contract or agreement; or
- b. The Limits of Insurance shown in the Declarations;

whichever is less.

This endorsement shall not increase the applicable Limits of Insurance shown in the Declarations.

3. With respect to the insurance afforded to these additional insureds, the following additional exclusion applies:

This insurance does not apply to:

- a. "Bodily injury", "property damage" or "personal and advertising injury" arising out of the rendering of, or the failure to render, any professional architectural, engineering or surveying services, including:
  - (1) The preparing, approving, or failing to prepare or approve, maps, shop drawings, opinions, reports, surveys, field orders, change orders or drawings and specifications; or
  - (2) Supervisory, inspection, architectural or engineering activities.

This exclusion applies even if the claims against an additional insured allege negligence or other wrongdoing in the supervision, hiring, employment, training or monitoring of others by that insured, if the "occurrence" which caused the "bodily injury" or "property damage", or the offense which caused the "personal and advertising injury", involved the rendering of or failure to render any professional services by you with respect to your providing engineering, architectural or surveying services in your capacity as an engineer, architect or surveyor.

## SECTION III – LIMITS OF INSURANCE AMENDMENTS

### A. Damage To Premises Rented To You

Paragraph 6. is replaced by the following:

- 6. Subject to Paragraph 5. above, the most we will pay under Coverage A for damages because of "property damage" to any one premises, while rented to you, or in the case of damage by fire, lightning, explosion or sprinkler leakage, while rented to you or temporarily occupied by you with permission of the owner is the greater of:
  - a. \$300,000; or
  - b. The amount shown next to the Damage To Premises Rented To You Limit in the Declarations.

However, the provisions of this paragraph do not apply if Damage To Premises Rented To You Coverage is excluded by endorsement.

### B. Medical Expense Limit

Paragraph 7. is replaced with the following:

- 7. Subject to Paragraph 5. above, the most we will pay under Coverage C for all medical expenses because of "bodily injury" sustained by any one person is the greater of:
  - a. \$10,000; or
  - b. The amount shown next to the Medical Expense Limit in the Declarations.

This insurance does not apply if coverage for Medical Expenses is excluded either by the provisions of the coverage part or by endorsement.

## SECTION IV – COMMERCIAL GENERAL LIABILITY CONDITIONS AMENDMENTS

### A. Knowledge Of Occurrence

Item 2. **Duties In The Event Of Occurrence, Offense, Claim or Suit** is amended by adding the following:

- e. You must give us or our authorized representative prompt notice of an “occurrence”, claim or loss only when the “occurrence”, claim or loss is known to:
  - (1) You, if you are an individual;
  - (2) A partner, if you are a partnership;
  - (3) An executive officer or insurance manager, if you are a corporation; or
  - (4) A member or manager, if you are a limited liability company.

### B. Other Insurance

Item 4. **Other Insurance, b. Excess Insurance (1) (a) (ii)** is replaced by the following:

- (ii) That is fire, lightning, explosion or sprinkler leakage insurance for premises rented to you or temporarily occupied by you with permission of the owner;

### C. Unintentional Failure To Disclose Hazards

Item 6. **Representations** is replaced by the following:

#### 6. Representations And Unintentional Failure To Disclose Hazards

- a. By accepting this policy, you agree:
  - (1) The statements in the Declarations are accurate and complete;
  - (2) Those statements are based upon representations you made to us; and
  - (3) We have issued this policy in reliance upon your representations.
- b. If you unintentionally fail to disclose any hazards existing at the inception date of your policy, we will not deny coverage under this Coverage Part because of such failure. However, this provision does not affect our right to collect additional premium or exercise our right of cancellation or non-renewal.

### D. Waiver of Subrogation

Item 8. **Transfer of Rights of Recovery Against Others to Us** is hereby amended by the addition of the following:

We waive any right of recovery we may have because of payments we make for injury or damage arising out of your ongoing operations or "your work" done under a written contract, executed prior to loss, requiring such waiver with that person or organization and included in the "products-completed operations hazard". However, our rights may only be waived prior to the "occurrence" giving rise to the injury or damage for which we make payment under this Coverage Part. The insured must do nothing after a loss to impair our rights. At our request, the insured will bring "suit" or transfer those rights to us and help us enforce those rights.

## SECTION V – DEFINITIONS AMENDMENTS

### A. Insured Contract Amended

Paragraph 9. a. is replaced by the following:

- a. A contract for a lease of premises. However, that portion of the contract for a lease of premises that indemnifies any person or organization for damage by fire, lightning, explosion or sprinkler leakage to premises while rented to you or temporarily occupied by you with permission of the owner is not an “insured contract”;

### B. Personal And Advertising Injury Redefined

Paragraph 14. d. and e. are replaced by the following:

- d. Oral, written, televised, videotaped or electronic publication of material that slanders or libels a person or organization or disparages a person’s or organization’s goods, products or service;
- e. Oral, written, televised, videotaped or electronic publication of material that violates a person’s right of privacy;



STATE OF WASHINGTON

Department of Labor & Industries

## Certificate of Workers' Compensation Coverage

May 1, 2024

WA UBI No.	603 037 300
L&I Account ID	185,472-01
Legal Business Name	MOVHER LLC
Doing Business As	MOVHER LLC
Workers' Comp Premium Status:	Account is current.
Estimated Workers Reported (See Description Below)	Quarter 1 of Year 2024 "11 to 20 Workers"
Account Representative	Employer Services Help Line, (360) 902-4817
Licensed Contractor?	No

### What does "Estimated Workers Reported" mean?

Estimated workers reported represents the number of full time position requiring at least 480 hours of work per calendar quarter. A single 480 hour position may be filled by one person, or several part time workers.

### Industrial Insurance Information

Employers report and pay premiums each quarter based on hours of employee work already performed, and are liable for premiums found later to be due. **Industrial insurance accounts have no policy periods, cancellation dates, limitations of coverage or waiver of subrogation** (See [RCW 51.12.050](#) and [51.16.190](#)).





**License Information:**

[New search](#) [Back to results](#)

**Entity name:** ARROW CONCRETE AND ASPHALT SPECIALTIES, LLC

**Business name:** ARROW CONCRETE AND ASPHALT SPECIALTIES, LLC.

**Entity type:** [Limited Liability Company](#)

**UBI #:** 601-619-703

**Business ID:** 001

**Location ID:** 0001

**Location:** Active

**Location address:** 12301 E EMPIRE AVE  
SPOKANE VALLEY WA 99216-1231

**Mailing address:** 9915 E TRENT AVE  
SPOKANE VALLEY WA 99206-4204

**Excise tax and reseller permit status:** [Click here](#)

**Secretary of State status:** [Click here](#)

**Endorsements**

Endorsements held at this location	License #	Count	Details	Status	Expiration date	First issuance date
<a href="#">Colville General Business - Non-Resident</a>				Active	Jul-31-2024	Jul-10-2023
<a href="#">Deer Park General Business - Non-Resident</a>				Active	Apr-30-2024	May-09-2017
<a href="#">Liberty Lake General Business - Non-Resident</a>				Active	Apr-30-2024	Aug-16-2021
<a href="#">Millwood General Business</a>				Active	Apr-30-2024	Oct-14-2019
<a href="#">Minor Work Permit</a>				Active	Apr-30-2024	Jul-01-2004
<a href="#">Richland General Business - Non-Resident</a>				Active	Feb-28-2025	Mar-05-2024
<a href="#">Spokane General Business - Non-Resident</a>	T12011346BUS			Active	Apr-30-2024	Oct-15-2012
<a href="#">Spokane Valley General Business</a>				Active	Apr-30-2024	Apr-24-2009

**Governing People** May include governing people not registered with Secretary of State



**Governing people**

**Title**

ARROW CONSTRUCTION HOLDINGS LLC

**Registered Trade Names**

**Registered trade names**

**Status**

**First issued**

ARROW CONCRETE AND ASPHALT SPECIALTIES, LLC.

Active

Feb-07-2023

[View Additional Locations](#)

The Business Lookup information is updated nightly. Search date and time: 4/12/2024 8:40:18 AM

**Contact us**

How are we doing?

**Take our survey!**

Don't see what you expected?

**Check if your browser is supported**



**Agenda Sheet for City Council:****Committee:** Public Safety **Date:** 06/03/2024**Committee Agenda type:** Discussion**Date Rec'd**

5/29/2024

**Clerk's File #**

ORD C36527

**Cross Ref #**

OPR 2024-0460

**Project #****Council Meeting Date:** 06/10/2024**Submitting Dept**

FIRE

**Bid #****Contact Name/Phone**

ANNE RAVEN (509)625-7091

**Requisition #****Contact E-Mail**

ARAVEN@SPOKANECITY.ORG

**Agenda Item Type**

Special Budget Ordinance

**Council Sponsor(s)**

PDILLON MCATHCART LNAVARRETE

**Agenda Item Name**

SPECIAL BUDGET ORDINANCE - CO-RESPONSE AGREEMENT AND EXPANSION

**Agenda Wording**

Special budget ordinance appropriating revenue and expenditures related to agreement between SFD and the University of Washington towards the expansion of the Behavioral Response Unit program.

**Summary (Background)**

Spokane Fire is requesting approval of agreement with the University of WA towards the expansion of the Behavioral Response Unit program. Fire will provide services and do all things necessary for, or incidental to, the performance work, as set forth in the Scope of Work. Upon completion of benchmark services, Fire will receive up to \$100,000 in 2024 and another \$100,000 in 2025. Special budget ordinance is requested to appropriate \$100,000 that will be used to procure two vehicles.

Lease? NO Grant related? NO Public Works? NO

**Fiscal Impact**

Approved in Current Year Budget? NO

Total Cost \$ 100,000

Current Year Cost \$ 100,000

Subsequent Year(s) Cost \$ 100,000

**Narrative**

SFD will receive \$100,000 in payments in 2024 and an additional \$100,000 in 2025 upon benchmark completion of deliverables per agreement with Univ. of Washington.

**Amount****Budget Account**

Revenue \$ 100,000 # 1970-35130-99999-34221-99999

Expense \$ 100,000 # 1970-35130-94220-56404-99999

Select \$ #

Select \$ #

\$ #

\$ #



**Continuation of Wording, Summary, Approvals, and Distribution**

**Agenda Wording**

**Summary (Background)**

**Approvals**

<b><u>Dept Head</u></b>	O'BERG, JULIE
<b><u>Division Director</u></b>	O'BERG, JULIE
<b><u>Accounting Manager</u></b>	SCHMITT, KEVIN
<b><u>Legal</u></b>	PICCOLO, MIKE
<b><u>For the Mayor</u></b>	PICCOLO, MIKE

**Additional Approvals**

<b><u>MANAGEMENT &amp;</u></b>	STRATTON, JESSICA

**Distribution List**

	Fire Accounting fireaccounting@spokanecity.org
Kevin Schmitt kschmitt@spokanecity.org	Anne Raven araven@spokanecity.org
Julie O'Berg joberg@spokanecity.org	Sue Raymon sraymon@spokanecity.org

## Council Briefing Paper

### Public Safety & Community Health Committee

<b>Committee Date</b>	June 3rd, 2024
<b>Submitting Department</b>	Fire
<b>Contact Name</b>	Anne Raven
<b>Contact Email &amp; Phone</b>	<a href="mailto:araven@spokanecity.org">araven@spokanecity.org</a> 625-7091
<b>Council Sponsor(s)</b>	Councilmembers Dillon, Cathcart & Navarrete
<b>Select Agenda Item Type</b>	<input checked="" type="checkbox"/> Discussion    Time Requested: 5min
<b>Agenda Item Name</b>	Special Budget Ordinance – Co-Response Agreement and Expansion
<b>Grant Item</b>	<input type="checkbox"/> Yes <input checked="" type="checkbox"/> No
<b>Proposed Council Action</b>	<input checked="" type="checkbox"/> Approval to proceed to Legislative Agenda
<b>Summary</b>  <b>What is the specific purpose or need for the budget adjustment?</b>  <b>What changes or developments have triggered this request?</b>	<p>The Spokane Fire Department is requesting approval of agreement with the University of Washington towards the expansion of the department's BRU program.</p> <p>SFD will provide services, and otherwise do all things necessary for or incidental to the performance work, as set forth in the Scope of Work. Upon completion of benchmark services, SFD will receive up to \$100,000 in 2024 and another \$100,000 in 2025.</p> <p>Special budget ordinance is requested to appropriate \$100,000 that will be used to procure two vehicles assigned to the BRU/CARES unit. Additional CARES members cannot perform their duties without assigned vehicles.</p>
<b>Fiscal Impact</b> <b>Approved in current year budget?</b> <input type="checkbox"/> Yes <input checked="" type="checkbox"/> No <input type="checkbox"/> N/A Total Cost: <u>\$100,000</u> Current year cost: \$100,000 Subsequent year(s) cost: \$100,000  <b>Funding Source</b> <input checked="" type="checkbox"/> One-time <input type="checkbox"/> Recurring <input type="checkbox"/> N/A Specify funding source: Program revenue Is this funding source sustainable for future years, months, etc? Yes – funds will be spent on one-time expenses  <b>Expense Occurrence</b> <input checked="" type="checkbox"/> One-time <input type="checkbox"/> Recurring <input type="checkbox"/> N/A  Other budget impacts: (revenue generating, match requirements, etc.)	
<b>Operations Impacts (If N/A, please give a brief description as to why)</b>  <ul style="list-style-type: none"> <li>• What are the net impacts this adjustment will have on the specifically affected line items? <i>Net zero impact on the Fire/EMS fund as the department will receive \$100,000 in currently unbudgeted revenues.</i></li> <li>• What operational changes will occur because of this adjustment?</li> </ul>	

*Expansion of the BRU/CARES unit in the Spokane Fire Department*

- What are the potential risks or consequences of not approving the budget adjustment?

*New personnel would be without transportation and be unable do homeless outreach, home visits, substance use disorder outreach, meeting with stakeholders, community education and public engagement opportunities.*

- Describe how this proposal aligns with current City Policies, including the Comprehensive Plan, Sustainability Action Plan, Capital Improvement Program, Neighborhood Master Plans, Council Resolutions, and others?

*Aligns with the plans to address the opioid use disorder, homelessness, and provide services to other vulnerable populations in our community.*

**What current racial and other inequities might this special budget ordinance address?**

***The CARES Teams need updated vehicles to be operational. The focus of the work at CARES is to address the inequities that the most vulnerable people in Spokane face. The team addresses the barriers people encounter when trying to access services. Finding the right services and resources that are culturally appropriate and respectful is central to the goals of CARES.***

ORDINANCE NO C36527

An ordinance amending Ordinance No. C36467, passed by the City Council November 27, 2023, and entitled, "An ordinance adopting the Annual Budget of the City of Spokane for 2024, making appropriations to the various funds of the City of Spokane government for the fiscal year ending December 31, 2024, and providing it shall take effect immediately upon passage," and declaring an emergency.

WHEREAS, subsequent to the adoption of the 2024 budget Ordinance No. C36467, as above entitled, and which passed the City Council November 27, 2023, it is necessary to make changes in the appropriations of the Fire/EMS Fund, which changes could not have been anticipated or known at the time of making such budget ordinance; and

WHEREAS, this ordinance has been on file in the City Clerk's Office for five days; - Now, Therefore,

The City of Spokane does ordain:

Section 1. That in the budget of the Fire/EMS fund, and the budget annexed thereto with reference to the Fund, the following changes be made:

- 1) Increase revenue by \$100,000.
  - A) Of the increased revenue, \$100,000 is provided by University of Washington solely for EMS services.
- 2) Increase appropriation by \$100,000.
  - A) Of the increased appropriation, \$100,000 is to be provided solely for vehicles.

Section 2. It is, therefore, by the City Council declared that an urgency and emergency exists for making the changes set forth herein, such urgency and emergency arising from agreement for the expansion of the SFD BRU Unit and because of such need, an urgency and emergency exists for the passage of this ordinance, and also, because the same makes an appropriation, it shall take effect and be in force immediately upon its passage.

Passed by the City Council on \_\_\_\_\_

\_\_\_\_\_  
Council President

Attest:

Approved as to form:

\_\_\_\_\_  
City Clerk

\_\_\_\_\_  
Assistant City Attorney

\_\_\_\_\_  
Mayor

\_\_\_\_\_  
Date

\_\_\_\_\_  
Effective Date

**Agenda Sheet for City Council:****Committee:** Urban Experience **Date:** 05/13/2024**Committee Agenda type:** Discussion**Date Rec'd**

5/13/2024

**Clerk's File #**

ORD C36528

**Cross Ref #****Project #****Council Meeting Date:** 06/10/2024**Submitting Dept**

MAYOR

**Bid #****Contact Name/Phone**

ADAM 6776

**Requisition #****Contact E-Mail**

AMCDANIEL@SPOKANECITY.ORG

**Agenda Item Type**

First Reading Ordinance

**Council Sponsor(s)**

BWILKERSON ZZAPPONE

**Agenda Item Name**

0520 - MAYOR'S OFFICE STREAMLINING LICENSE REQUIREMENTS FOR ALL

**Agenda Wording**

This ordinance streamlines licensing requirements for all ages venues by eliminating separate and additional requirements for All Ages Venues and Teen Clubs by rolling it up into the general regulations for Entertainment Facilities.

**Summary (Background)**

This ordinance streamlines licensing requirements for all ages venues by eliminating separate and additional requirements for All Ages Venues and Teen Clubs by rolling it up into the general regulations for Entertainment Facilities. The ordinance also removes outdated dancing regulations and language about the size and lighting of dance floors better regulated through the building or fire codes. The ordinance also updates the code section to reflect the City's current noise ordinance.

Lease? NO

Grant related? NO

Public Works? NO

**Fiscal Impact**

Approved in Current Year Budget? N/A

Total Cost

\$

Current Year Cost

\$

Subsequent Year(s) Cost

\$

**Narrative**

The licensing costs remain the same. There is no fiscal impact of this ordinance.

**Amount****Budget Account**

Select

\$

#

Select

\$

#

Select

\$

#

Select

\$

#

\$

#

\$

#





## Continuation of Wording, Summary, Approvals, and Distribution

### Agenda Wording

### Summary (Background)

#### **Approvals**

##### Dept Head

JONES, GARRETT

##### Division Director

##### Accounting Manager

BUSTOS, KIM

##### Legal

SCHOEDEL, ELIZABETH

##### For the Mayor

PICCOLO, MIKE

#### **Additional Approvals**

#### **Distribution List**

amcdaniel@spokanecity.org

zzappone@spokanecity.org

## Committee Agenda Sheet

### Urban Experience Committee

<b>Committee Date</b>	5/13/2024
<b>Submitting Department</b>	Mayor's Office   Council Office
<b>Contact Name</b>	Adam McDaniel   Councilmember Zack Zappone
<b>Contact Email &amp; Phone</b>	<a href="mailto:amcdaniel@spokanecity.org">amcdaniel@spokanecity.org</a>   zzappone@spokanecity.org
<b>Council Sponsor(s)</b>	<u>Zappone at the request of the Mayor's Office; Wilkerson</u>
<b>Select Agenda Item Type</b>	<input type="checkbox"/> Consent <input checked="" type="checkbox"/> Discussion    Time Requested: 5minutes
<b>Agenda Item Name</b>	Streamlining license requirements for All Ages Venues
<b>Proposed Council Action</b>	<input checked="" type="checkbox"/> Approval to proceed to Legislative Agenda <input type="checkbox"/> Information Only
<b>Summary (Background)</b>	This ordinance streamlines licensing requirements for all ages venues by eliminating separate and additional requirements for All Ages Venues and Teen Clubs by rolling it up into the general regulations for Entertainment Facilities. The ordinance also removes outdated dancing regulations and language about the size and lighting of dance floors better regulated through the building or fire codes. The ordinance also updates the code section to reflect the City's current noise ordinance.
<b>Fiscal Impact</b>	<p><b>Approved in current year budget?</b>    <input type="checkbox"/> Yes    <input type="checkbox"/> No    <input checked="" type="checkbox"/> N/A</p> <p>Total Cost: <u>\$0</u></p> <p>    Current year cost: \$0</p> <p>    Subsequent year(s) cost:</p> <p><b>Narrative:</b> <u>The licensing costs remain the same. There is no fiscal impact of this ordinance.</u></p> <p><b>Funding Source</b>    <input type="checkbox"/> One-time    <input type="checkbox"/> Recurring    <input checked="" type="checkbox"/> N/A</p> <p>Specify funding source: Select Funding Source*</p> <p>Is this funding source sustainable for future years, months, etc?</p> <p><b>Expense Occurrence</b>    <input type="checkbox"/> One-time    <input type="checkbox"/> Recurring    <input checked="" type="checkbox"/> N/A</p> <p>Other budget impacts: (revenue generating, match requirements, etc.)</p>
<b>Operations Impacts (If N/A, please give a brief description as to why)</b>	<p>What impacts would the proposal have on historically excluded communities?</p> <p>This ordinance attempts to make it easier to operate and provide all ages venues and entertainment to provide more entertainments opportunities for young people in the city of Spokane.</p> <p>How will data be collected, analyzed, and reported concerning the effect of the program/policy by racial, ethnic, gender identity, national origin, income level, disability, sexual orientation, or other existing disparities?</p> <p>No additional data will be collected or reported on this ordinance other than entertainment facility licenses tracked by Taxes and Licensing.</p> <p>How will data be collected regarding the effectiveness of this program, policy or product to ensure it is the right solution?</p>

No additional data will be collected or reported on this ordinance other than entertainment facility licenses tracked by Taxes and Licensing.

Describe how this proposal aligns with current City Policies, including the Comprehensive Plan, Sustainability Action Plan, Capital Improvement Program, Neighborhood Master Plans, Council Resolutions, and others?

Comprehensive Plan SH 3.1 Support for the Arts

Comprehensive Plan ED 7.6 Development Standards and Permitting Process

ORDINANCE NO C36528

An ordinance streamlining licensing requirements for entertainment facilities and all ages venues; repealing Sections 10.23A.040 and 10.23A.60 of the Spokane Municipal Code; amending Sections 04.04.020, 10.23A.020, 10.23A.030 and 10.70.100 of the Spokane Municipal Code.

**WHEREAS**, in 2017, the City Council unanimously passed Ordinance C35500 to streamline license fees for cabarets, teen clubs, and all ages venues by creating a general entertainment facilities license with one standard fee; and

**WHEREAS**, Ordinance C35500 also removed references to “immoral and obscene dancing” and removed parking requirements for concerts, carnivals, and festivals; and

**WHEREAS**, some municipal code sections remain that reference teen clubs and all ages venues; and

**WHEREAS**, there is a desire to streamline all entertainment facilities licensing and regulations.

**NOW, THEREFORE**, the City of Spokane does ordain:

**Section 1.** That Section 04.04.020 of Chapter 04.04 of the Spokane Municipal Code is amended to read as follows

**Section 04.04.020 Activities Requiring Registrations and Licenses**

- A. A person, including principals and agents, needs a current and valid license issued under this chapter to begin or to continue, directly or indirectly, any activity provided for in Division II of Title 10 SMC, whether as a commercial business or for nonprofit or charitable purposes.
- B. Persons pursuing ordinary vocations and businesses on private property by private means need a class I license and registration, for such activities as:
  - 1. peddling merchandise, and
  - 2. solicitation of money or things of value.
- C. Persons conducting activities which have a potential to cause social or economic evil, or useful occupations which may under certain circumstances become a public or private nuisance offensive or dangerous to health, safety, morals, or good order, need a class II license for such activities as:
  - 1. maintaining places and devices of amusement (~~(, including teen clubs, cabarets,)~~) and entertainment facilities;

2. keeping of animals;
3. building relocation;
4. certain contracting;
5. commercial use and sale of fireworks;
6. private or special police;
7. dealing in used goods;
8. operating for-hire vehicles

D. Persons claiming a private right in or making extraordinary use of public property need a class III license for such activities as:

1. moving buildings;
2. operating cable television;
3. certain contracting;
4. collecting garbage or commercial recyclables ([SMC 13.02.0204](#));
5. distributing natural gas;
6. maintaining mechanical newspaper vendors;
7. operating telephone and telegraph equipment;
8. operating sidewalk cafes; and
9. doing commercial tree work.

**Section 2.** That Section 10.23A.020 of Chapter 10.23A of the Spokane Municipal Code is amended to read as follows:

**Section 10.23A.020 License Required**

- A. No person may conduct or maintain an entertainment or amusement facility without first obtaining an entertainment facility license.

- B. The entertainment facility license is a class IIA license as provided in [chapter 4.04 SMC](#).
- C. Anyone conducting or operating a business, event, or venue where concerts, dances, carnivals, or circuses (~~((, teen club, all-ages venue, or a cabaret))~~) are presented to the public as a regular course of doing business shall have a license or permit issued under this chapter, unless otherwise exempted by this chapter.

**Section 3.** That Section 10.23A.030 of Chapter 10.23A of the Spokane Municipal Code is amended to read as follows:

**Section 10.23A.030 Special Regulations for Entertainment Facilities**

- A. No person under the age of eighteen years may be in a premise licensed under this section between the hours of two a.m. and six a.m., nor shall any licensee permit such minor to be on the premises between those hours.
- B. No licensee may conduct any dancing activity between the hours of two a.m. and six a.m. without prior special permission of the license officer.

~~((C. No licensee or employee may do, or permit to be done:~~

- ~~1. soliciting of dancing partners or the purchase of refreshments on a commission basis; or~~
- ~~2. dancing with patrons or customers on a commission or tip basis;~~

~~D. A licensee with a dance floor must maintain illumination at a minimum level of three foot-candles at a plane three feet above the dance floor.))~~

E. C. The operator of an entertainment facility:

- 1. shall not permit music to emanate off the premises in violation of (~~([chapter 10.08D, SMC](#) (noise control))~~) [SMC 10.70](#), except where outdoor entertainment venues are provided in approved outdoor patio areas;

~~((2. shall keep the portion of the premises devoted to the preparation of food entirely separate from the dance floor~~

- ~~3. if dancing is permitted, shall provide a dance floor of not less than one hundred fifty square feet with each side being at least ten feet long;~~
- ~~4. if there is an elevated dance floor, shall provide a dance floor not higher than eighteen inches above the surrounding floor or closer than six feet from~~

~~the nearest patron))~~

5. 2. shall ensure the subject premises comply with all applicable building, fire, and zoning codes; and

~~((F.))~~ D. Outdoor entertainment venues may be provided in approved outdoor patio areas pursuant to the following:

1. Sound levels shall be in compliance with (~~(chapter 10.08D, SMC)~~) SMC 10.70.
2. Sound levels must be turned down or terminated in response to neighborhood complaints or as directed by a police officer.
3. No outdoor entertainment allowed after ten p.m., provided that, at the time of the initial permit application, a venue may request and shall receive a permit allowing for extended hours to midnight on Friday and Saturday if the venue is located no closer than one hundred feet from a residential zone, which shall be measured from the property lines between the venue and the nearest residential property.

~~((G.))~~ E. A violation under this section is a class one civil infraction for each violation.

**Section 4.** That Section 10.23A.040 of Chapter 10.23A of the Spokane Municipal Code is repealed.

**Section 5.** That Section 10.23A.060 of Chapter 10.23A of the Spokane Municipal Code is repealed.

**Section 6.** That Section 10.70.100 of Chapter 10.70 of the Spokane Municipal Code is amended to read as follows:

#### **Section 10.70.100 Entertainment Facilities**

- A. Entertainment facilities and amusement facilities as defined in 10.23A.010(B) SMC (~~(and including, adult cabarets and teen clubs)~~) must obtain permits and comply with the requirements under chapter 10.23A SMC.
- B. Entertainment facilities and amusement facilities (~~(including adult cabarets and teen clubs)~~) which are granted a permit for indoor entertainment under chapter 10.23A SMC are prohibited from allowing sound that is plainly audible to a person of normal sensitivities fifty feet from the establishment. Doors to the facilities must remain closed during business hours, except for ingress and egress.

C. Entertainment facilities which are granted a permit for outdoor entertainment are prohibited from allowing sound that is plainly audible to a person of normal sensitivities more than one hundred feet from the facility.

D. Enforcing authority: police department.

PASSED by the City Council on \_\_\_\_\_

\_\_\_\_\_  
Council President

Attest:

Approved as to form:

\_\_\_\_\_  
City Clerk

\_\_\_\_\_  
City Attorney

\_\_\_\_\_  
Mayor

\_\_\_\_\_  
Date

\_\_\_\_\_  
Effective Date