

TABLE OF CONTENTS

CITY OF SPOKANE STANDARD PLANS – SECTION H

X-### = Revised Standard Plan
***X-### = New Standard Plan

[Back to Main TOC](#)

<u>Plan No.</u>	<u>Plan Title</u>	<u>Current Plan Date</u>
H-101	Monument Frame and Cover	5/07
H-102	<i>See Std. Plan J-112E</i>	
H-103	Standard Bench Mark	5/07
H-104	Monument Frame Riser Ring	5/07
H-105	Monument Installation	9/19

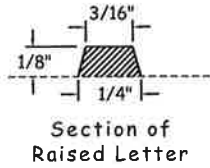

NOTES:
 Per Section 9-22.1, the casting shall be Gray-Iron casting, AASHTO M 105, Class 30B. The cover and seat shall be machined so as to have perfect contact around the entire circumference and full width of bearing surface.

Approximate Weights:
 Case: 60#
 Cover: 19#
 Total: 79#

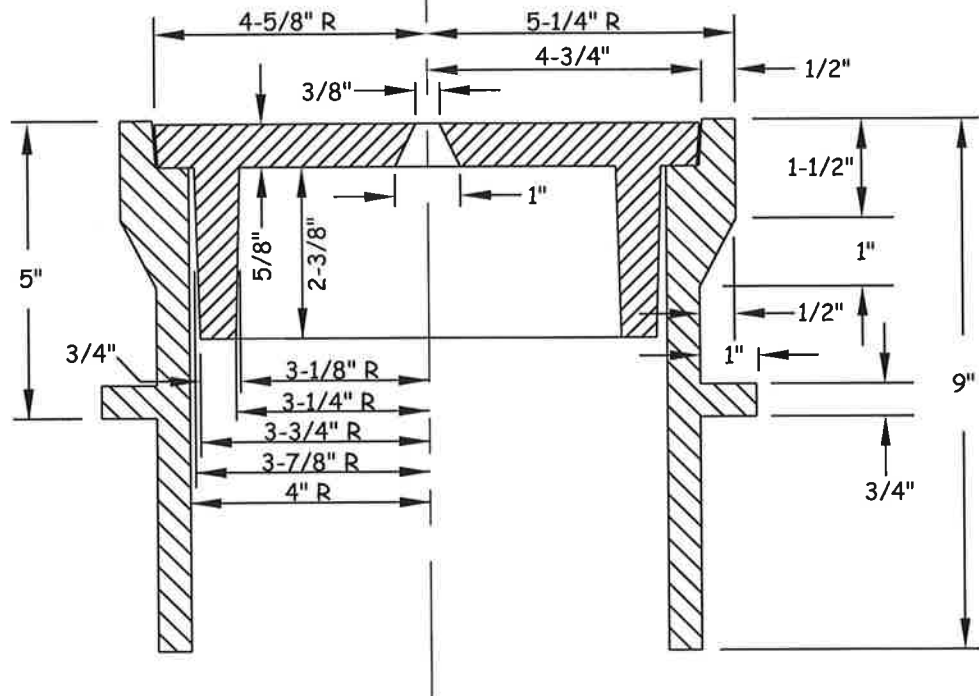

APPROVED BY

 DIRECTOR, ENGINEERING SERVICES TOM L. ARNOLD, P.E.

 PRINCIPAL ENGINEER, DESIGN GARY S. NELSON, P.E.

ADOPTED: 2/1986
 REVISED: 05/2007
 SUPERSEDES: 7/1991
 CHECKED BY: JAG
 SCALE: NTS
 DWG/REV. BY: PCF/RLB

MONUMENT FRAME AND COVER

ENGINEERING SERVICES
 CITY OF SPOKANE, WASHINGTON

STANDARD
 PLAN No.
 H-101

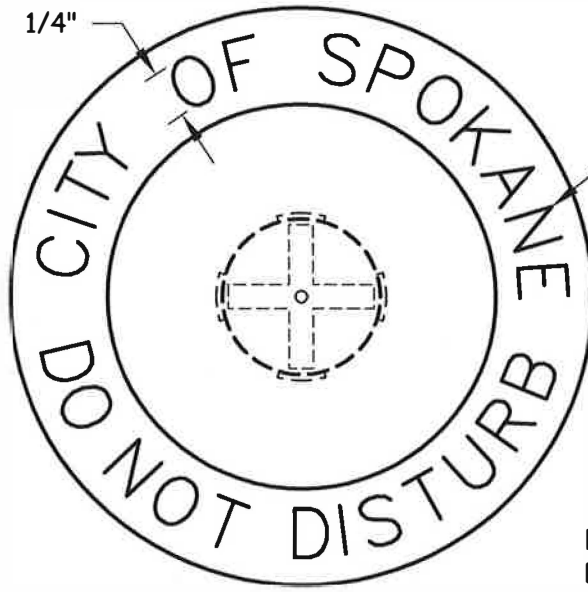
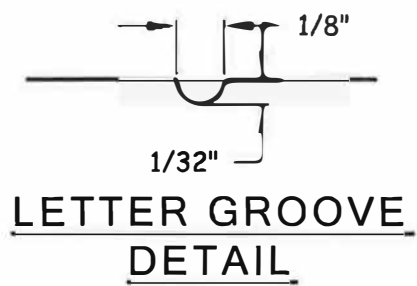
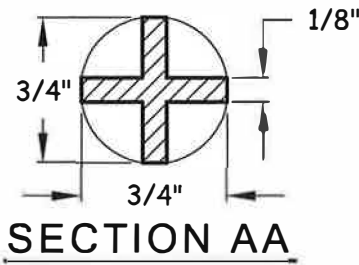

LETTERS MADE W/ $\frac{1}{8}$ "
GROOVE, $\frac{1}{32}$ " DEEP
(SEE DETAIL)

NOTE: CAST BRASS
DISC FROM YELLOW
BRASS SAE 41.

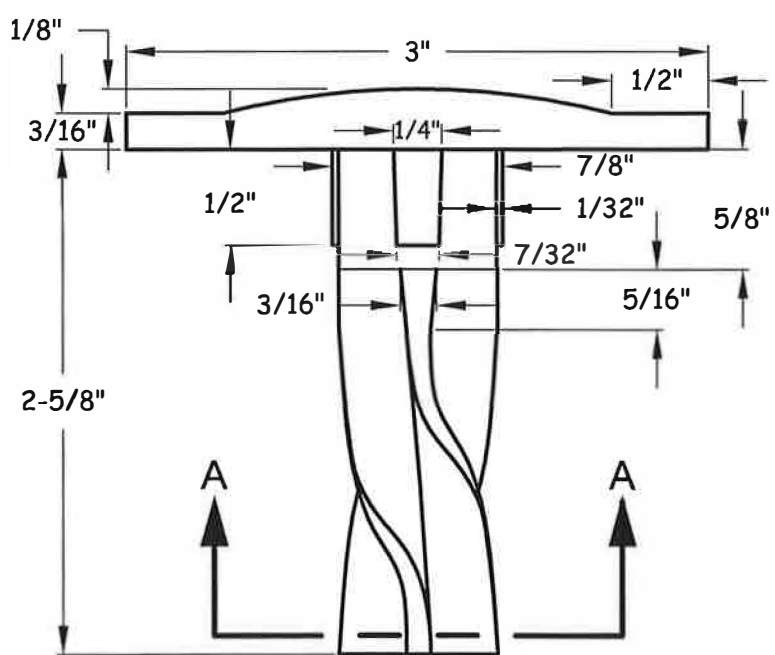

APPROVED BY
Tom L. Arnold
DIRECTOR, ENGINEERING SERVICES TOM L. ARNOLD, P.E.
Gary S. Nelson
PRINCIPAL ENGINEER, DESIGN GARY S. NELSON, P.E.

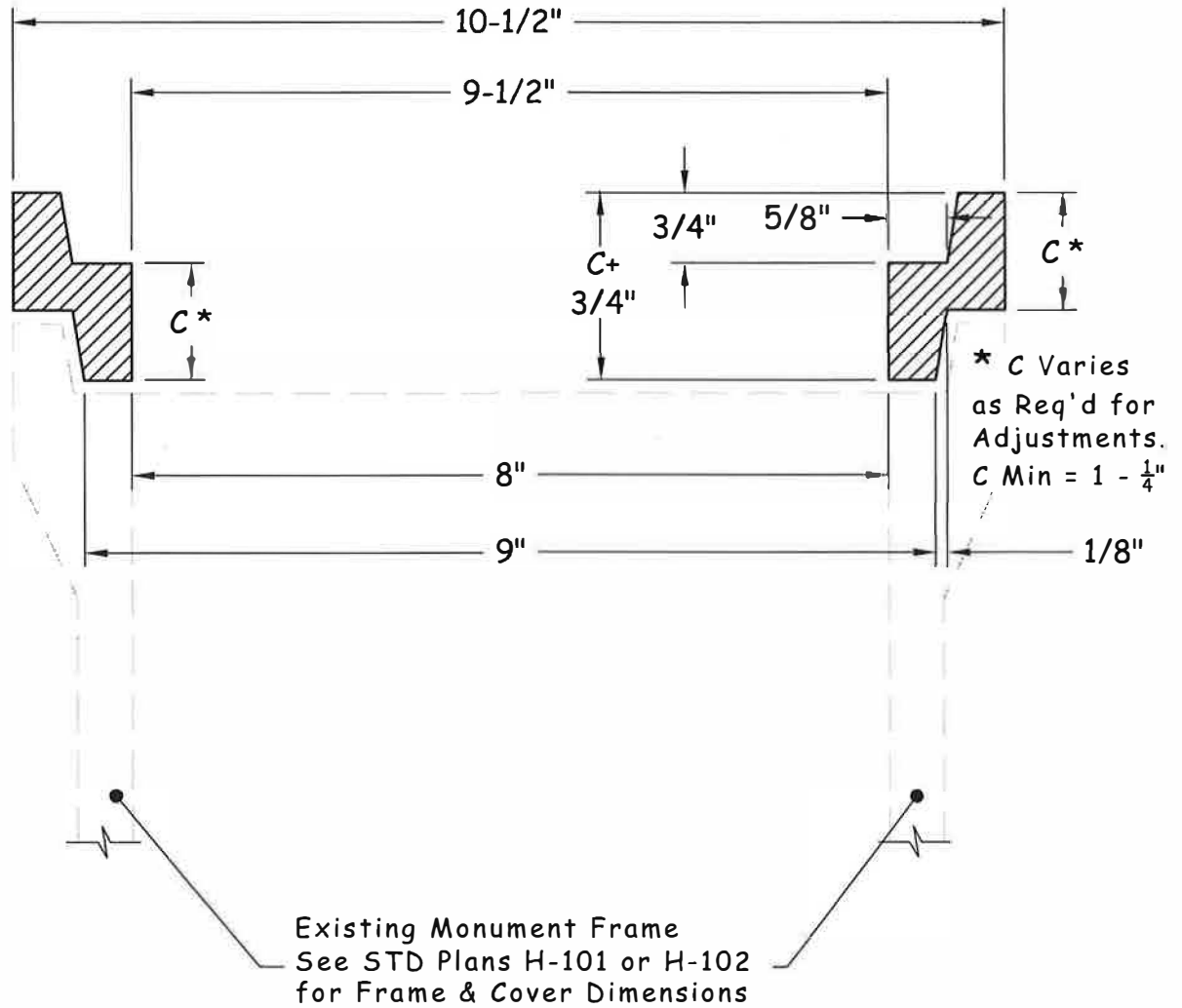

ADOPTED: 02/1986
REVISED: 05/2007
SUPERSEDES: H-102, 02/86
CHECKED BY: JAG
SCALE: NTS
DWG/REV. BY: SRM

STANDARD BENCH MARK
ENGINEERING SERVICES
CITY OF SPOKANE, WASHINGTON
STANDARD PLAN No. H-103



NOTES:

Per section 9-22.1, the casting shall be Gray-Iron casting, AASHTO M 105, class 30B. The seat of the riser shall be machined so as to have perfect contact around the entire circumference and full width of bearing surface.

APPROVED BY

 DIRECTOR, ENGINEERING SERVICES TOM L. ARNOLD, P.E.

 PRINCIPAL ENGINEER, DESIGN GARY S. NELSON, P.E.

ADOPTED: 02/1986
 REVISED: 05/2007
 SUPERSEDES: H-101A, 02/86
 CHECKED BY: JAG
 SCALE: NTS
 DWG/REV. BY: SRM



MONUMENT FRAME RISER RING

ENGINEERING SERVICES
 CITY OF SPOKANE, WASHINGTON

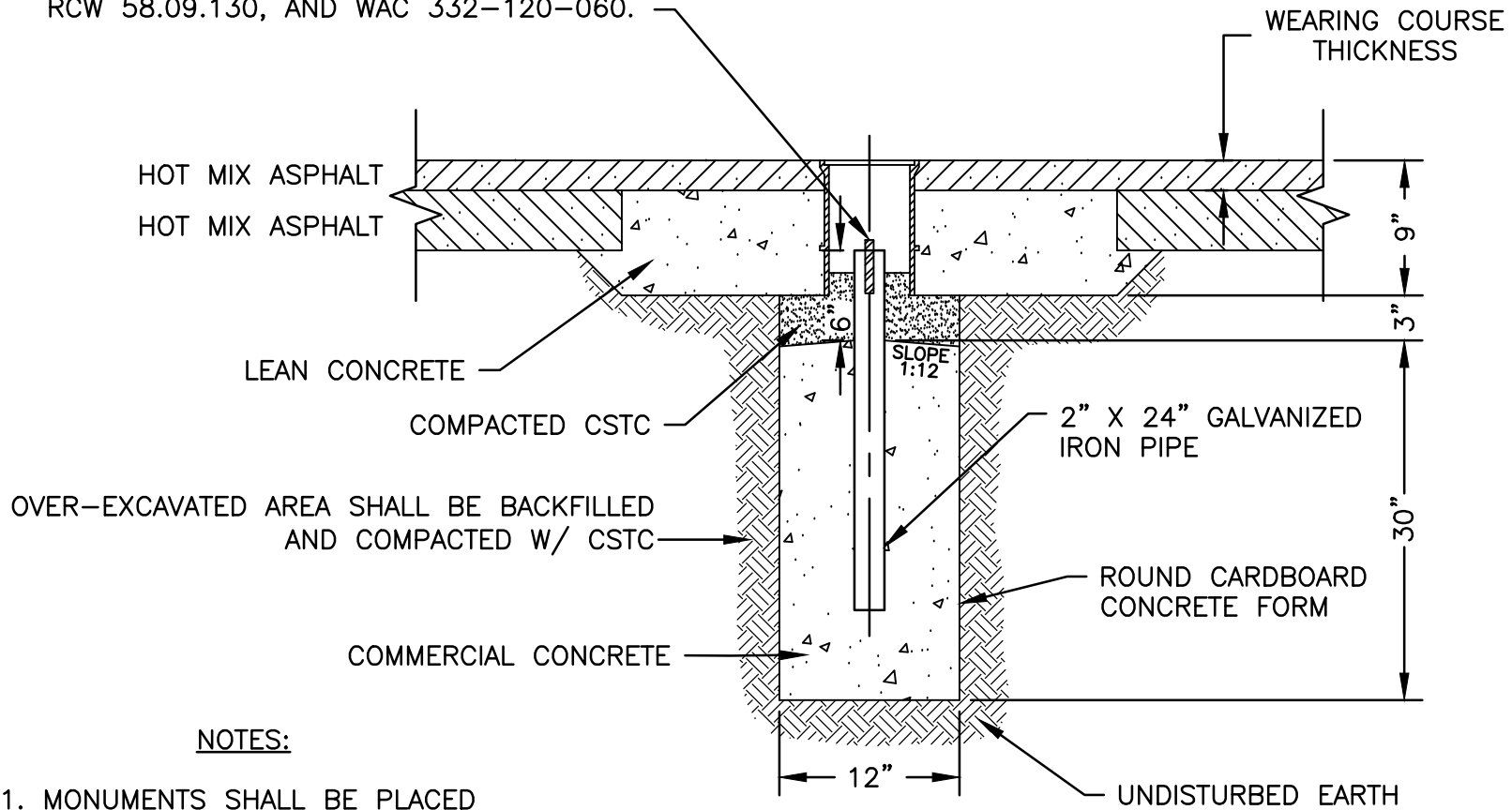

STANDARD
 PLAN No.
 H-104

FILL GALVANIZED IRON PIPE W/QUICK SET CONCRETE.
 INSERT ANY SUITABLE MONUMENT PER RCW 58.09.120,
 RCW 58.09.130, AND WAC 332-120-060.



NOTES:

1. MONUMENTS SHALL BE PLACED BY A PROFESSIONAL LAND SURVEYOR LICENSED IN THE STATE OF WASHINGTON.
2. MONUMENTS SHALL PLACED PRIOR TO HMA WEARING COURSE.

<p>APPROVED BY</p>  <p>ENGINEERING SERVICES DIRECTOR KYLE TWOHIG</p>  <p>CITY ENGINEER DAN BULLER, P.E.</p>	<p>ADOPTED: _____</p> <p>REVISED: 09/2019</p> <p>SUPERSEDES: 04/2012</p> <p>CHECKED BY: SJS</p> <p>SCALE: NTS</p> <p>DWG/REV. BY: LWK/MLD</p>	<p style="text-align: center;">MONUMENT INSTALLATION</p> <p style="text-align: center;">ENGINEERING SERVICES CITY OF SPOKANE, WASHINGTON</p>	<p>STANDARD PLAN No. H-105</p>
---	---	---	---