

TABLE OF CONTENTS

CITY OF SPOKANE STANDARD PLANS – SECTION Z

- B-101B** = Revised Standard Plan
 ***W-108A = New Standard Plan
 #A-1 = Renumbered Standard Plan

[Back to Main TOC](#)

<u>Plan No.</u>	<u>Plan Title</u>	<u>Current Plan Date</u>
Z-101	Manhole –48"	10/19
Z-102	Manhole –54" & 60"	10/19
Z-103	Manhole – 72"	10/19
Z-104	Manhole – 96"	10/19
Z-105	Manhole –48", Shallow	10/19
Z-106	Manhole –72", Shallow	10/19
Z-106A	Manhole –96", Shallow	10/19
Z-107	Type V Manhole	10/19
Z-108	Manhole – Reducing Slab, Reinforcement Details	4/04
Z-109	Manhole Step Details	4/12
Z-110	Manhole – Interior Channel Drop	5/07
Z-111	Manhole – Interior D.I.P. Drop	10/19
Z-112	Manhole – Exterior D.I.P. Drop	10/19
Z-113	Manhole – Pipe Invert Elevations	4/04
Z-114	Sewer Cleanout	10/19
Z-115	Side Sewer – Riser Connection	2/18
Z-116	Side Sewer – Typical Connection	1/17
Z-117	Manhole Channel Detail	2/19
Z-118	CB, DW & MH Base Slab and Foundation Details (previously B-122)	12/98

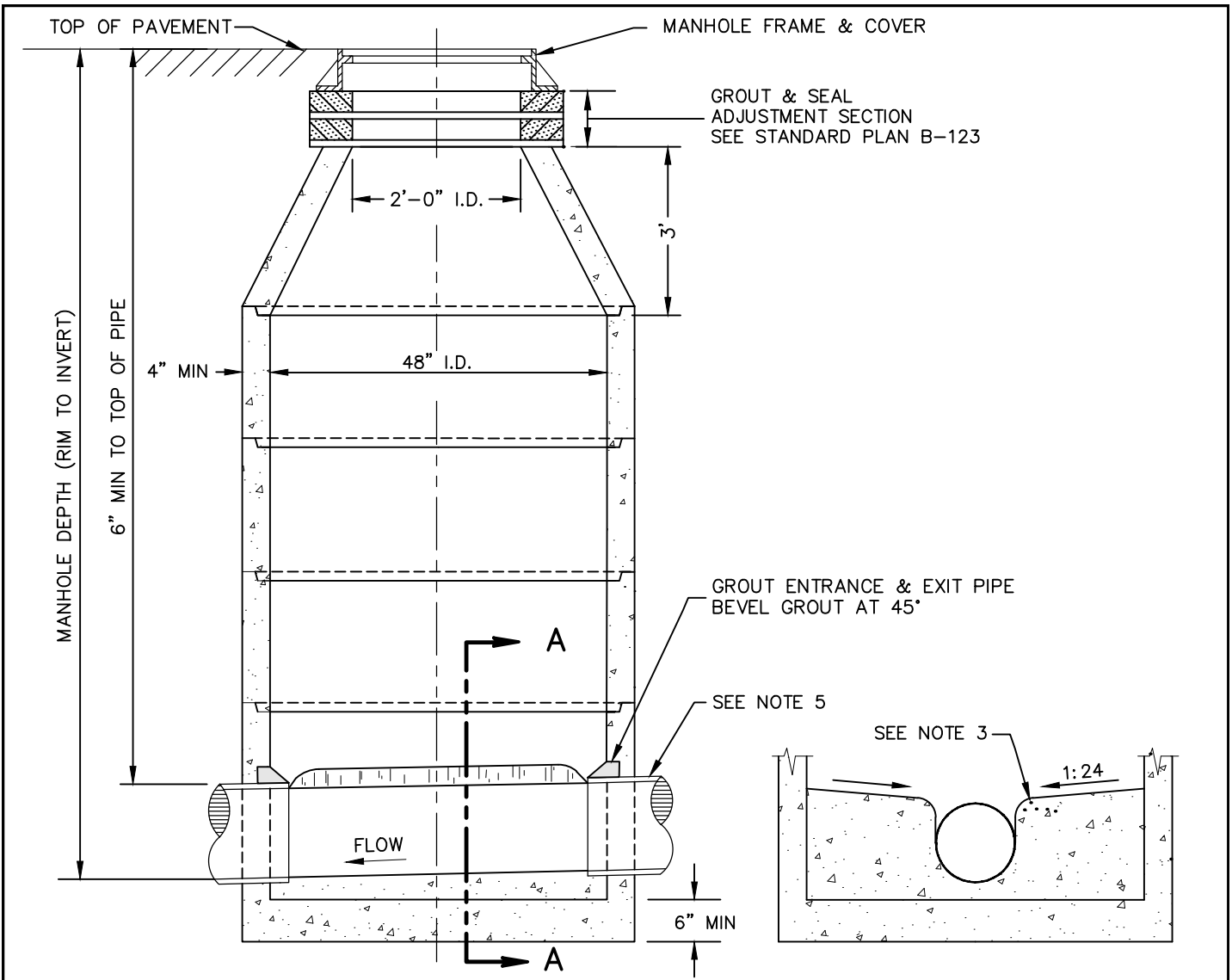

SECTION A-A

NOTES:

1. SEE STANDARD PLANS A-12/A-13 FOR MANHOLE FRAME & COVER, AND Z-118 FOR BASE & FOUNDATION.
2. MANHOLE STEPS ARE REQUIRED, SEE Z-109.
3. FORM SHELF & SMOOTH CONTINUOUS CHANNEL WITH COMMERCIAL GRADE CONCRETE.
4. MANHOLES EXCEEDING A 20 FT DEPTH SHALL HAVE BARREL SECTIONS WITH MINIMUM 54" DIAMETER, SEE Z-102.
5. MAX PIPE DIA = 24". ANGULAR RUNS EXCEEDING 45° OR ADDITIONAL JUNCTIONS MAY REQUIRE LARGER MANHOLE. DESIGN VERIFICATION IS REQUIRED.
6. SEE STANDARD PLAN A-8 FOR ADJUSTMENT SECTION REQUIREMENTS.

<p style="text-align: center;">APPROVED BY</p> <p style="text-align: center;">ENGINEERING SERVICES DIRECTOR KYLE TWOHIG</p> <p style="text-align: center;">CITY ENGINEER DAN BULLER, P.E.</p>	<p>ADOPTED: _____</p> <p>REVISED: 10/2019</p> <p>SUPERSEDES: 04/2018</p> <p>CHECKED BY: SJS</p> <p>SCALE: NTS</p> <p>REVISED BY: LWK/MLD</p>	<p>MANHOLE - 48"</p> <p>ENGINEERING SERVICES CITY OF SPOKANE, WASHINGTON</p>	<p>STANDARD PLAN No. Z-101</p>
---	--	---	---

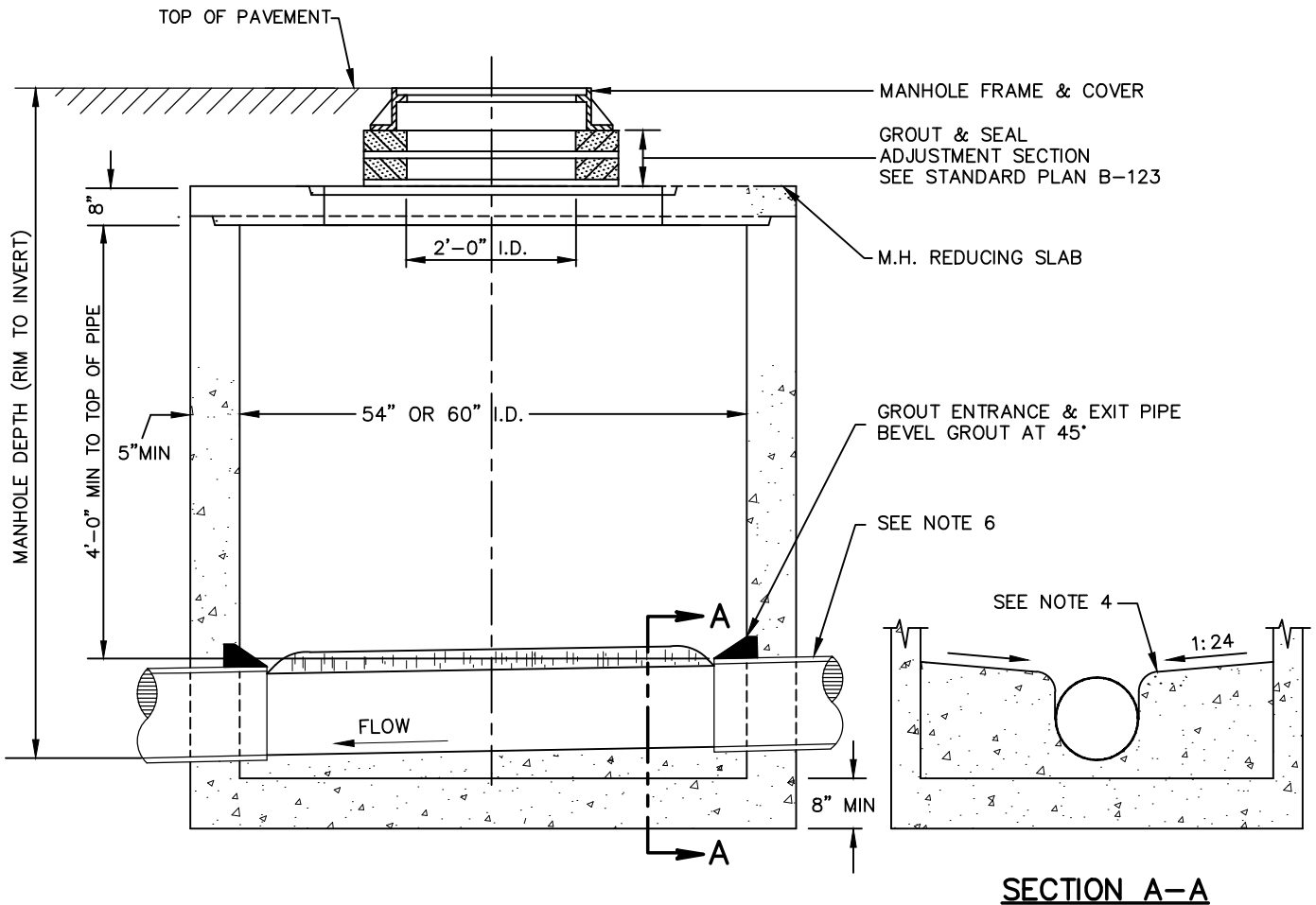

NOTES:

1. SEE STANDARD PLANS A-12/A-13 FOR MANHOLE FRAME & COVER, AND Z-118 FOR BASE & FOUNDATION.
2. MANHOLE STEPS ARE REQUIRED, SEE Z-109.
3. FORM SHELF & SMOOTH CONTINUOUS CHANNEL WITH COMMERCIAL GRADE CONCRETE.
4. REDUCING SLAB SHALL BE INSTALLED WITH A 24" OPENING CENTERED ON THE SLAB.
5. MAX PIPE DIA. = 30" FOR 54" MANHOLE AND 36" FOR 60" MANHOLE. ANGULAR RUNS EXCEEDING 45° OR ADDITIONAL JUNCTIONS MAY REQUIRE LARGER MANHOLE. DESIGN VERIFICATION IS REQUIRED.
6. SEE STANDARD PLAN A-8 FOR ADJUSTMENT SECTION REQUIREMENTS.

APPROVED BY

 ENGINEERING SERVICES DIRECTOR KYLE TWOHIG
 CITY ENGINEER DAN BULLER, P.E.

ADOPTED: _____
 REVISED: 10/2019
 SUPERSEDES: 04/2018
 CHECKED BY: SJS
 SCALE: NTS
 REVISED BY: LWK/MLD

MANHOLE - 54" & 60"			ENGINEERING SERVICES CITY OF SPOKANE, WASHINGTON	STANDARD PLAN No. Z-102

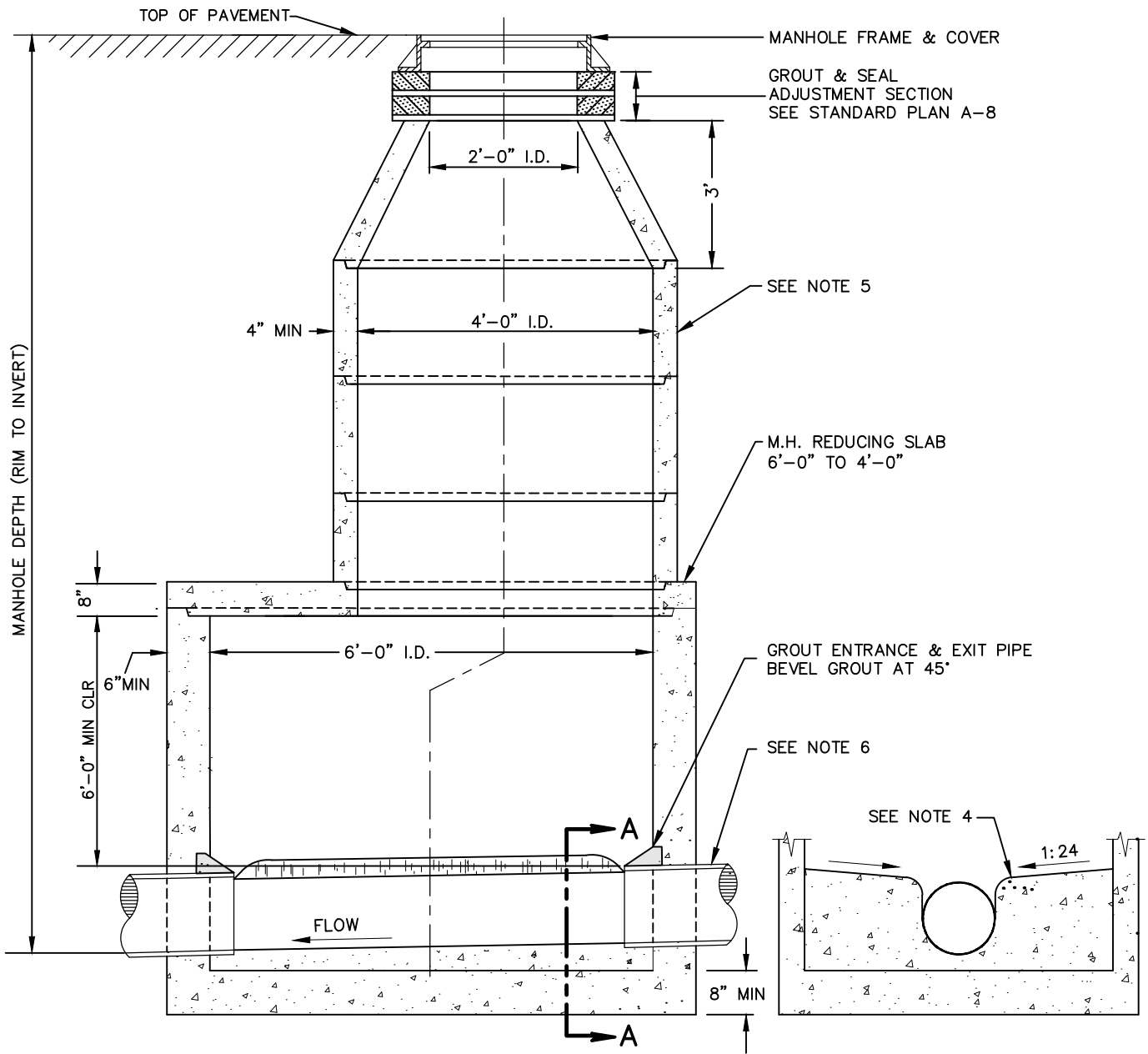

SECTION A-A

NOTES:

1. SEE STANDARD PLANS A-12/A-13 FOR MANHOLE FRAME & COVER, AND Z-118 FOR BASE & FOUNDATION.
2. MANHOLE STEPS ARE REQUIRED, SEE Z-109.
3. ACCESS HOLE TO BE CENTERED OVER CHANNEL.
4. FORM SHELF & SMOOTH CONTINUOUS CHANNEL WITH COMMERCIAL GRADE CONCRETE.
5. MANHOLES EXCEEDING A 20 FT DEPTH SHALL HAVE BARREL SECTIONS 54" I.D. OR GREATER IN WHICH CASE A BARREL DIA X 24" REDUCING SLAB SHALL BE USED IN PLACE OF THE CONE, 24" OPENING CENTERED ON SLAB.
6. MAX PIPE DIA. = 48" ANGULAR RUNS EXCEEDING 45° OR ADDITIONAL JUNCTIONS MAY REQUIRE LARGER MANHOLE. DESIGN VERIFICATION IS REQUIRED.
7. SEE STANDARD PLAN A-8 FOR ADJUSTMENT SECTION REQUIREMENTS.

<p style="text-align: center;">APPROVED BY</p> <p style="text-align: center;">ENGINEERING SERVICES DIRECTOR KYLE TWOHIG</p> <p style="text-align: center;">CITY ENGINEER DAN BULLER, P.E.</p>	<p>ADOPTED: _____</p> <p>REVISED: 10/219</p> <p>SUPERSEDES: 04/2018</p> <p>CHECKED BY: SJS</p> <p>SCALE: NTS</p> <p>REVISED BY: LWK/MLD</p>	<p style="font-size: 1.2em; font-weight: bold;">MANHOLE - 72"</p> <p style="text-align: center;">ENGINEERING SERVICES CITY OF SPOKANE, WASHINGTON</p>	<p>STANDARD PLAN No. Z-103</p>
---	---	---	---

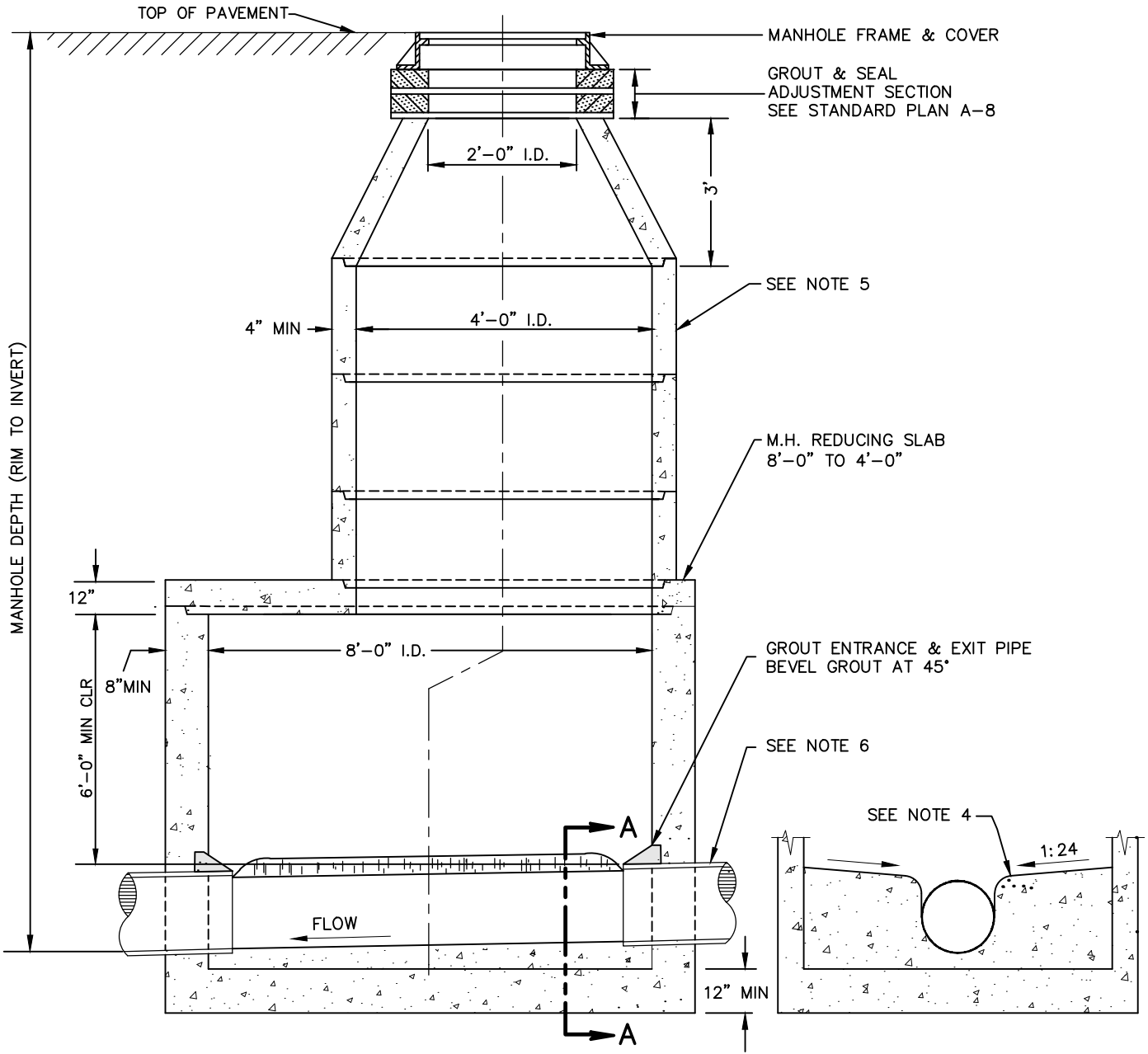

SECTION A-A

NOTES:

1. SEE STD PLANS A-12/A-13 FOR MANHOLE FRAME & COVER, AND Z-118 FOR BASE & FOUNDATION.
2. MANHOLE STEPS ARE REQUIRED, SEE Z-109.
3. ACCESS HOLE TO BE CENTERED OVER CHANNEL.
4. FORM SHELF & SMOOTH CONTINUOUS CHANNEL WITH COMMERCIAL GRADE CONCRETE.
5. MANHOLES EXCEEDING A 20 FT DEPTH SHALL HAVE BARREL SECTIONS 54" I.D. OR GREATER.
6. MAX PIPE DIA. = 72" ANGULAR RUNS EXCEEDING 45° OR ADDITIONAL JUNCTIONS MAY REQUIRE LARGER MANHOLE. DESIGN VERIFICATION IS REQUIRED.
7. SEE STANDARD PLAN A-8 FOR ADJUSTMENT SECTION REQUIREMENTS.

APPROVED BY

 ENGINEERING SERVICES DIRECTOR
 KYLE TWOHIG

 CITY ENGINEER
 DAN BULLER, P.E.

ADOPTED: _____
 REVISED: 10/2019
 SUPERSEDES: 04/2018
 CHECKED BY: SJS
 SCALE: NTS
 REVISED BY: LWK/MLD

MANHOLE - 96"		ENGINEERING SERVICES CITY OF SPOKANE, WASHINGTON	STANDARD PLAN No. Z-104
CITY OF SPOKANE, WASHINGTON			

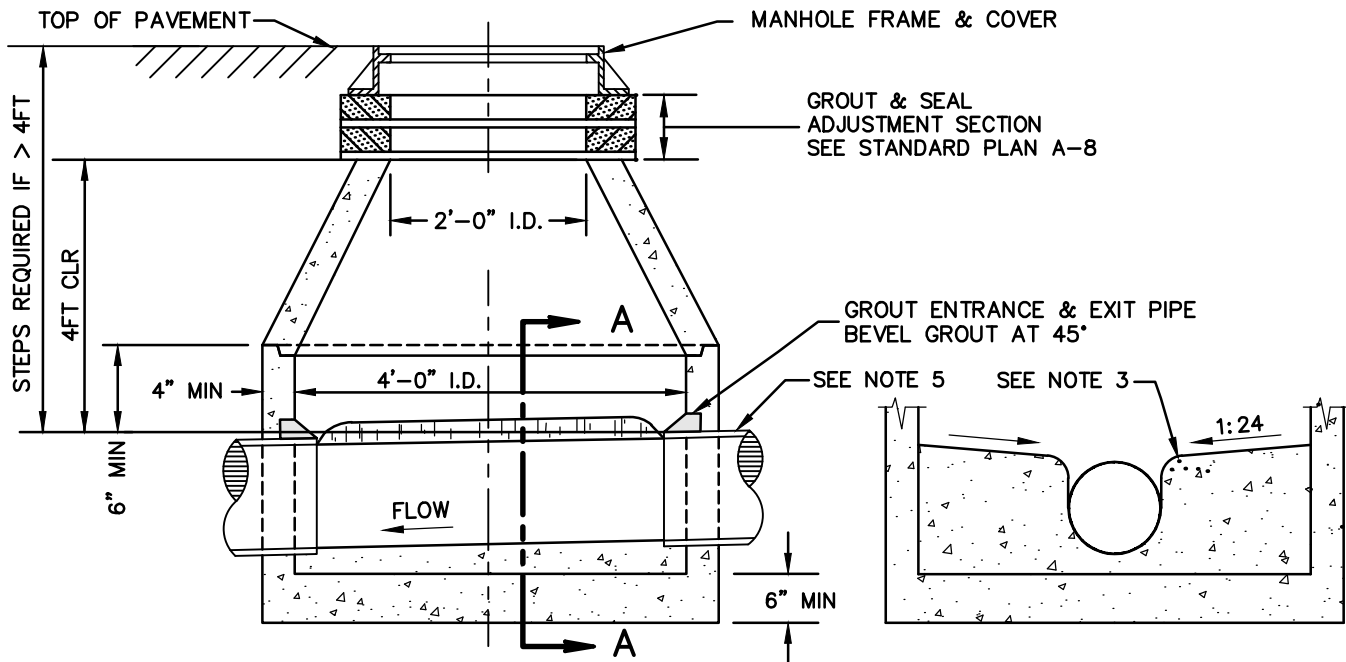

SECTION A-A

NOTES:

1. SEE STANDARD PLANS A-12/A-13 FOR MANHOLE FRAME & COVER, AND Z-118 FOR BASE & FOUNDATION.
2. SEE Z-109 FOR MANHOLE STEP DETAILS IF REQUIRED.
3. FORM SHELF & SMOOTH CONTINUOUS CHANNEL WITH COMMERCIAL GRADE CONCRETE.
4. IN GENERAL, SHALLOW MANHOLES ARE NOT ALLOWED. THIS DETAIL MAY BE ALLOWED WITH PRIOR PERMISSION OF THE SEWER DEPARTMENT ENGINEER WHERE SUFFICIENT VERTICAL CLEARANCE DOES NOT EXIST TO CONSTRUCT THE MANHOLE SHOWN ON Z-101. THIS DETAIL WILL NOT BE PERMITTED IN NEW INSTALLATIONS.
5. IN EXTREME SITUATIONS AND WITH APPROVAL OF THE SEWER DEPARTMENT ENGINEER, THE PIPE MAY BE LOCATED IN THE CONE AND THE BASE SLAB POURED IN PLACE.
6. SEE STANDARD PLAN A-8 FOR ADJUSTMENT SECTION REQUIREMENTS.

<p style="text-align: center;">APPROVED BY</p> <p style="text-align: center;">ENGINEERING SERVICES DIRECTOR KYLE TWOHIG</p> <p style="text-align: center;">CITY ENGINEER DAN BULLER, P.E.</p>	<p>ADOPTED: _____</p> <p>REVISED: <u>10/2019</u></p> <p>SUPERSEDES: <u>04/2018</u></p> <p>CHECKED BY: <u>SJS</u></p> <p>SCALE: <u>NTS</u></p> <p>REVISED BY: <u>LWK/MLD</u></p>	<p>MANHOLE - 48" SHALLOW</p> <p>ENGINEERING SERVICES CITY OF SPOKANE, WASHINGTON</p>	<p>STANDARD PLAN No. Z-105</p>
---	---	---	---

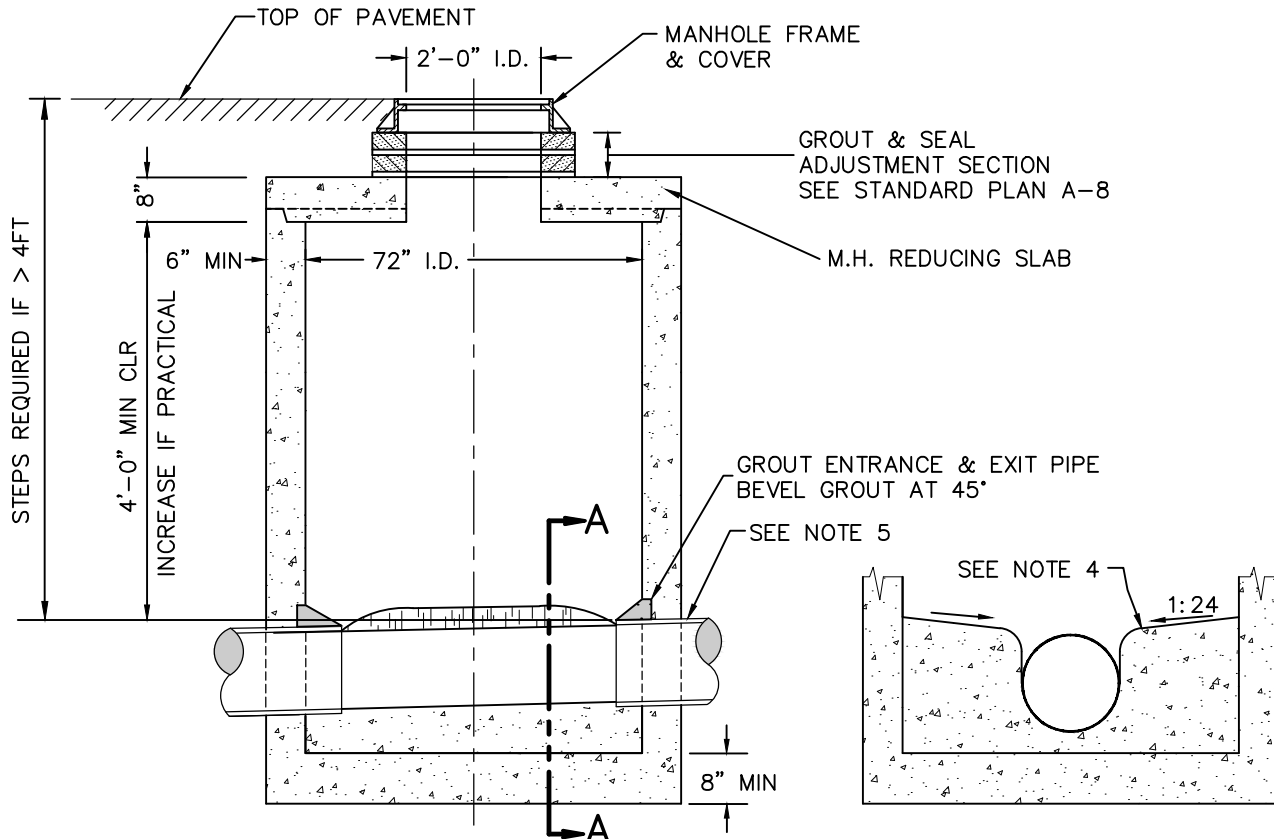

SECTION A-A

NOTES:

1. SEE STANDARD PLANS A-12/A-13 FOR FRAME & COVER, AND Z-118 FOR BASE & FOUNDATION.
2. SEE Z-109 FOR MANHOLE STEP DETAILS IF REQUIRED.
3. REDUCING SLAB SHALL BE INSTALLED WITH 24" OPENING CENTERED ON THE SLAB.
4. FORM SHELF & SMOOTH CONTINUOUS CHANNEL WITH COMMERCIAL GRADE CONCRETE.
5. MAX PIPE DIA. = 48". ANGULAR RUNS EXCEEDING 45° OR ADDITIONAL JUNCTIONS MAY REQUIRE LARGER MANHOLE. DESIGN VERIFICATION IS REQUIRED.
6. SEE STANDARD PLAN A-8 FOR ADJUSTMENT SECTION REQUIREMENTS.

<p style="text-align: center;">APPROVED BY</p> <p style="text-align: center;">ENGINEERING SERVICES DIRECTOR KYLE TWOHIG</p> <p style="text-align: center;">CITY ENGINEER DAN BULLER, P.E.</p>	<p>ADOPTED: _____</p> <p>REVISED: 10/2019</p> <p>SUPERSEDES: 04/2018</p> <p>CHECKED BY: SJS</p> <p>SCALE: NTS</p> <p>REVISED BY: LWK/MLD</p>	<p>MANHOLE – 72" SHALLOW</p> <p>ENGINEERING SERVICES CITY OF SPOKANE, WASHINGTON</p>	<p>STANDARD PLAN No. Z-106</p>
---	--	---	---

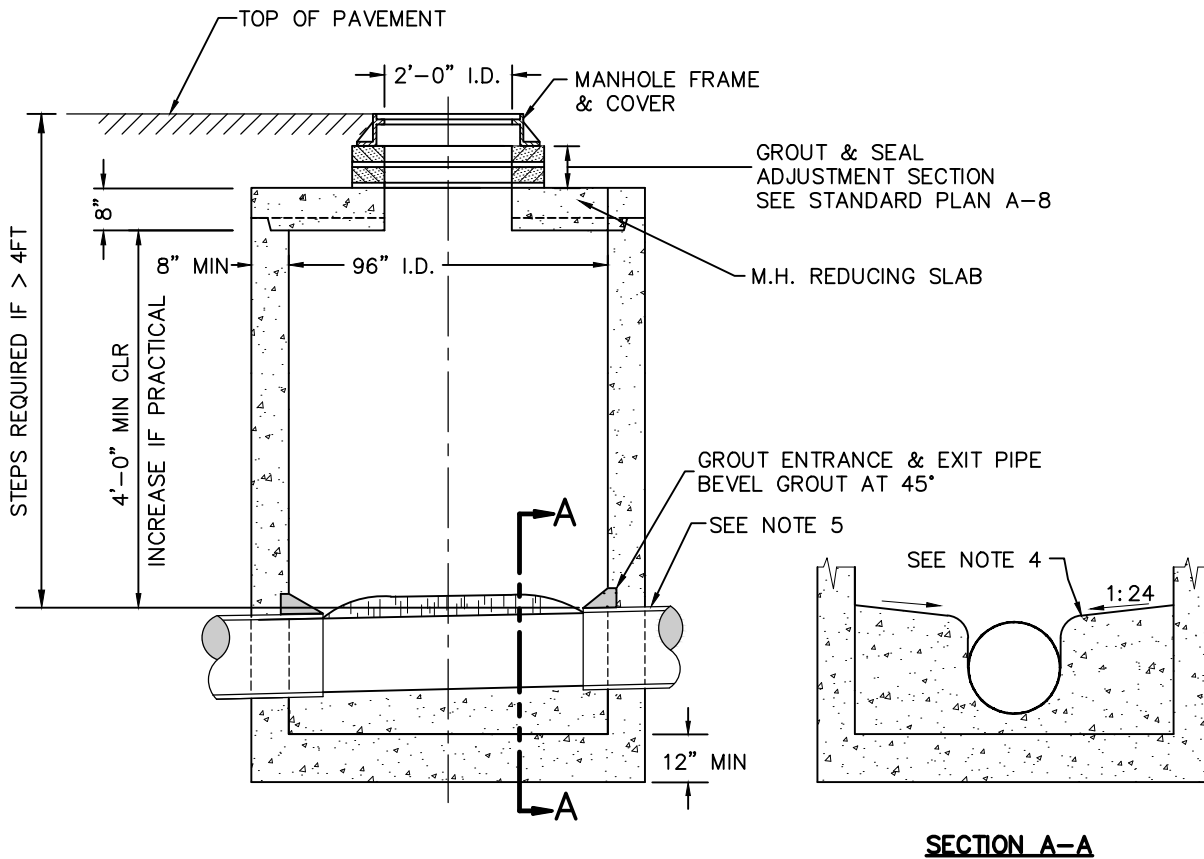

NOTES:

1. SEE STANDARD PLANS A-12/A-13 FOR FRAME & COVER, AND Z-118 FOR BASE & FOUNDATION.
2. SEE Z-109 FOR MANHOLE STEP DETAILS IF REQUIRED.
3. REDUCING SLAB SHALL BE INSTALLED WITH 24" OPENING CENTERED ON THE SLAB.
4. FORM SHELF & SMOOTH CONTINUOUS CHANNEL WITH COMMERCIAL GRADE CONCRETE.
5. MAX PIPE DIA. = 72". ANGULAR RUNS EXCEEDING 45° OR ADDITIONAL JUNCTIONS MAY REQUIRE LARGER MANHOLE. DESIGN VERIFICATION IS REQUIRED.
6. SEE STANDARD PLAN A-8 FOR ADJUSTMENT SECTION REQUIREMENTS.

<p style="text-align: center;">APPROVED BY</p> <p style="text-align: center;">ENGINEERING SERVICES DIRECTOR KYLE TWOHIG</p> <p style="text-align: center;">CITY ENGINEER DAN BULLER, P.E.</p>	<p>ADOPTED: _____</p> <p>REVISED: 10/2019</p> <p>SUPERSEDES: 04/2018</p> <p>CHECKED BY: SJS</p> <p>SCALE: NTS</p> <p>REVISED BY: LWK/MLD</p>	<p>MANHOLE – 96" SHALLOW</p> <p>ENGINEERING SERVICES CITY OF SPOKANE, WASHINGTON</p>	<p>STANDARD PLAN No. Z-106A</p>
---	--	---	--

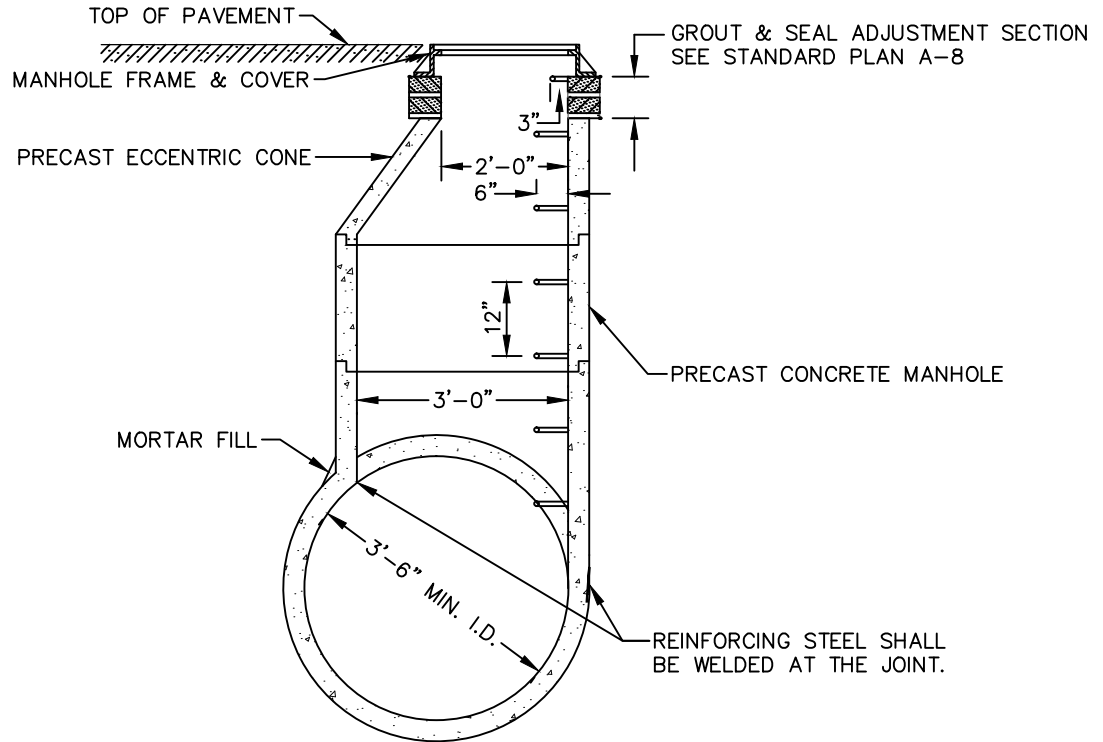

SECTION A-A

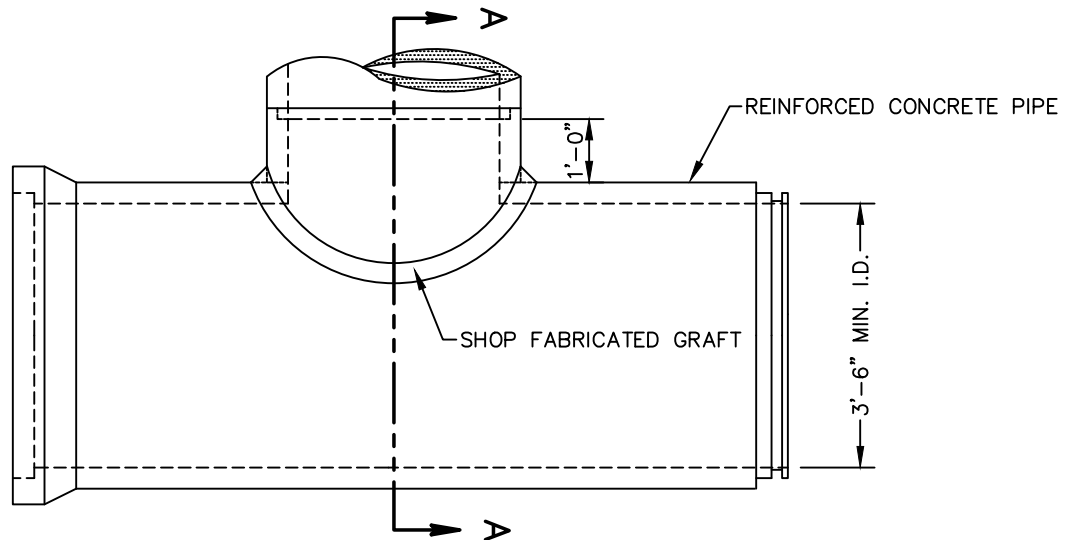

NOTES:

1. SEE SECTIONS 7-05 & 9-12.4 FOR PRECAST CONCRETE MANHOLES.
2. SEE STANDARD PLANS A-12 & A-13 FOR MANHOLE FRAME & COVER.
3. SEE STANDARD PLAN Z-109 FOR M.H. STEP DETAILS.
4. CONE & BARREL JOINT(S) MAY BE EITHER TONGUE & GROOVE OR REVERSE TONGUE & GROOVE.
5. CONE ADJUSTMENT SECTION & BARREL JOINT(S) TO BE SEALED PER SECS 7-05 & 9-04.
6. ADDITIONAL REINFORCING AND/OR SPECIAL BEDDING FOR THE REINFORCED CONC PIPE SHALL BE AS SPECIFIED.
7. RISER DIA MAY BE 4'-0" FOR REINFORCED CONC PIPE SIZES 4'-0" & LARGER.
8. SEE STANDARD PLAN A-8 FOR ADJUSTMENT SECTION REQUIREMENTS.

<p style="text-align: center;">APPROVED BY</p> <p style="text-align: center;">ENGINEERING SERVICES DIRECTOR KYLE TWOHIG</p> <p style="text-align: center;">CITY ENGINEER DAN BULLER, P.E.</p>	<p>ADOPTED: _____</p> <p>REVISED: 10/2019</p> <p>SUPERSEDES: 01/2017</p> <p>CHECKED BY: JAG</p> <p>SCALE: NTS</p> <p>DWG/REV. BY: MDH/MLD</p>	<p>MANHOLE – TYPE V</p> <p>ENGINEERING SERVICES CITY OF SPOKANE, WASHINGTON</p>	<p>STANDARD PLAN No. Z-107</p>
---	---	--	---

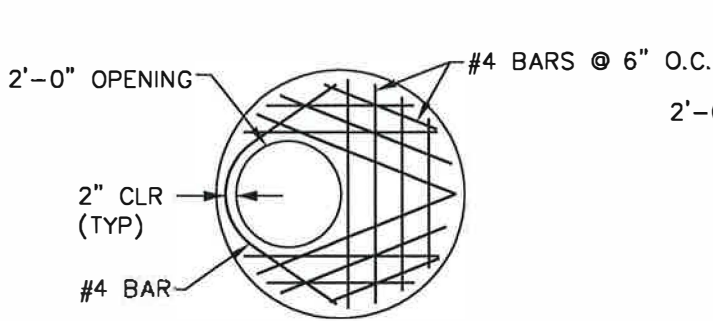

SLAB FOR 4'-0" I.D. MANHOLE

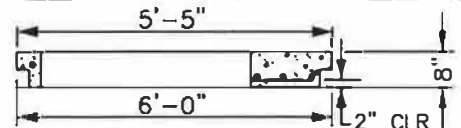
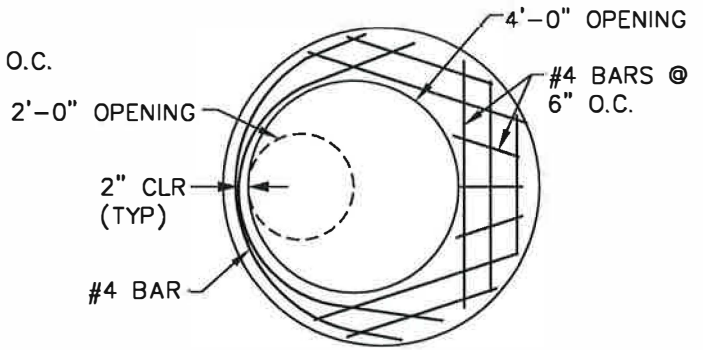

SLAB FOR 4'-6" I.D. MANHOLE

SLAB FOR 5'-0" I.D. MANHOLE

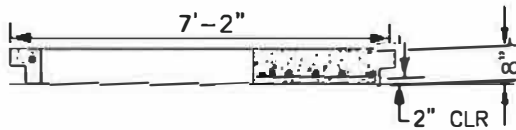
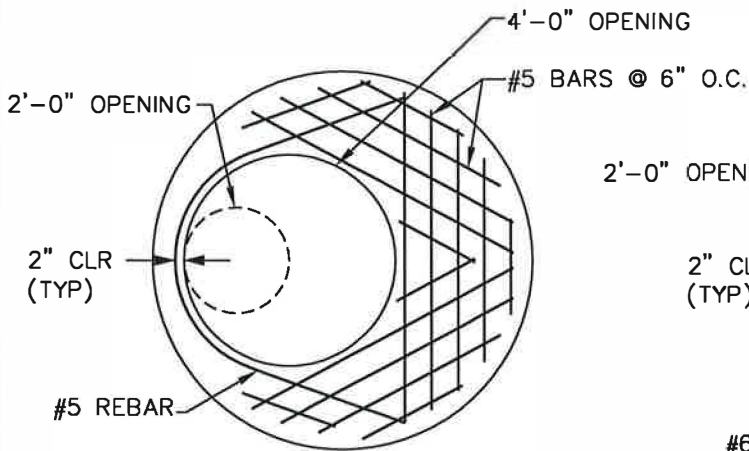

SLAB FOR 6'-0" I.D. MANHOLE

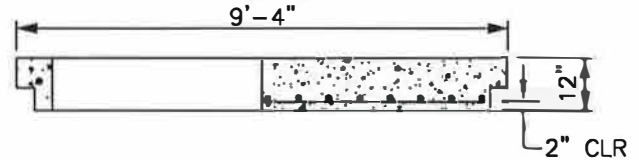
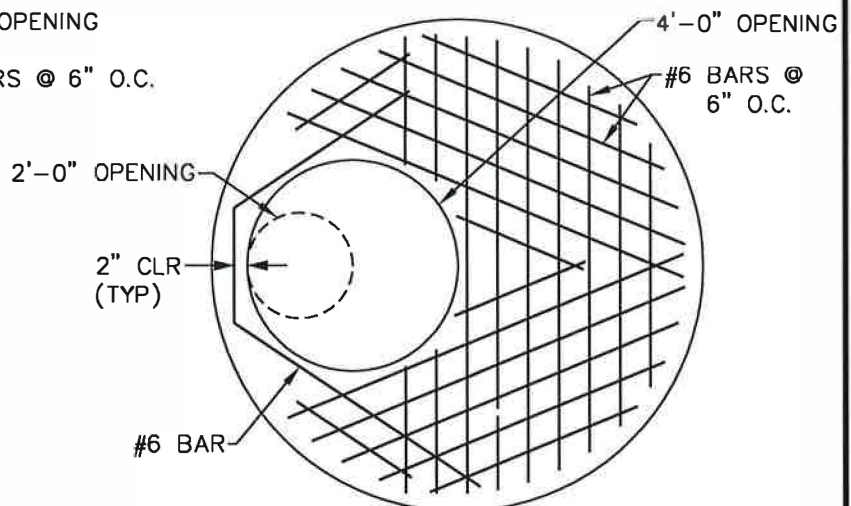

SLAB FOR 8'-0" I.D. MANHOLE

NOTES:

1. PLACE REBAR NEAR BTM FACE OF SLAB AT INDICATED CLEARANCES.
2. REINFORCING STEEL SHALL BE STD DEFORMED BAR; YIELD STRESS, $F_y = 40$ KSI.

APPROVED BY

 DIRECTOR, ENGINEERING SERVICES TOM L. ARNOLD, P.E.

 PRINCIPAL ENGINEER, DESIGN KEN M. BROWN, P.E.

ADOPTED: 2/86
 REVISED: 4/2004
 SUPERSEDES:
 SCALE: NTS
 DWG/REV. BY: MDH

MANHOLE - REDUCING SLAB
 REINFORCEMENT DETAILS
 ENGINEERING SERVICES
 CITY OF SPOKANE, WASHINGTON
 STANDARD PLAN No. Z-108

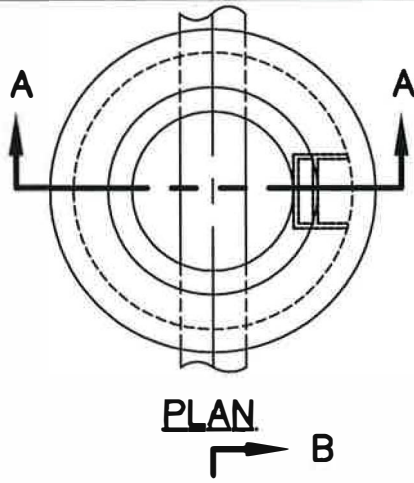

PLAN

B

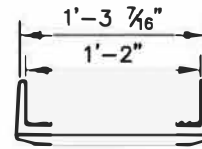
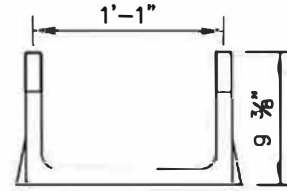

MANHOLE STEP

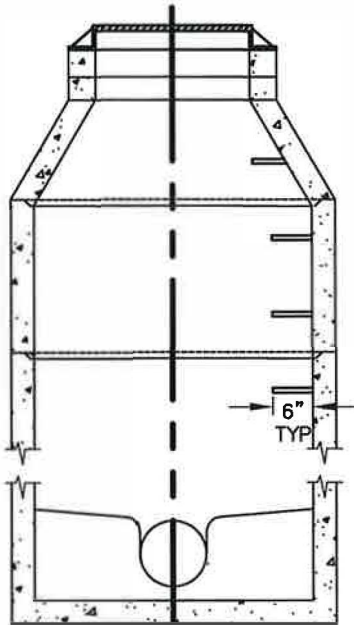

SECTION A-A

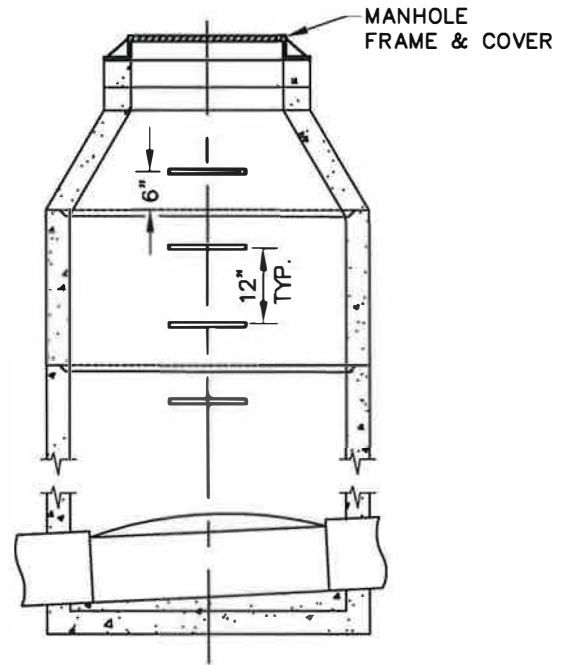

SECTION B-B

NOTES:

1. MANHOLE STEPS SHALL BE GROUTED INTO THE PRECAST CONCRETE WALL. STEPS SHALL BE UNIFORMLY SPACED AT 12" O.C. VERTICALLY, LEVELED HORIZONTALLY, & ALIGNED ALONG THE MANHOLE'S C/L.
2. MANHOLES W/ OUT REDUCING SLABS SHALL HAVE THE STEPS LOCATED ABOVE THE SHELF. MANHOLES WITH REDUCING SLABS SHALL HAVE THE STEPS CENTERED BELOW THE SLAB ACCESS HOLE & THE UPSTREAM PIPE.
3. MANHOLE STEPS SHALL BE POLYPROPYLENE W/ANTI-SLIP TREAD DESIGN & TWO REFLECTORS PER STEP.

APPROVED BY

 DIRECTOR, ENGINEERING SERVICES PERRY M. TAYLOR, P.E.

 PRINCIPAL ENGINEER, CONST. KENNETH M. BROWN, P.E.

ADOPTED: 02/1986
 REVISED: 04/2012
 SUPERSEDES: 09/2010
 CHECKED BY: SJS
 SCALE: NTS
 REVISED BY: LWK

MANHOLE STEP DETAILS			ENGINEERING SERVICES CITY OF SPOKANE, WASHINGTON	STANDARD PLAN No. Z-109

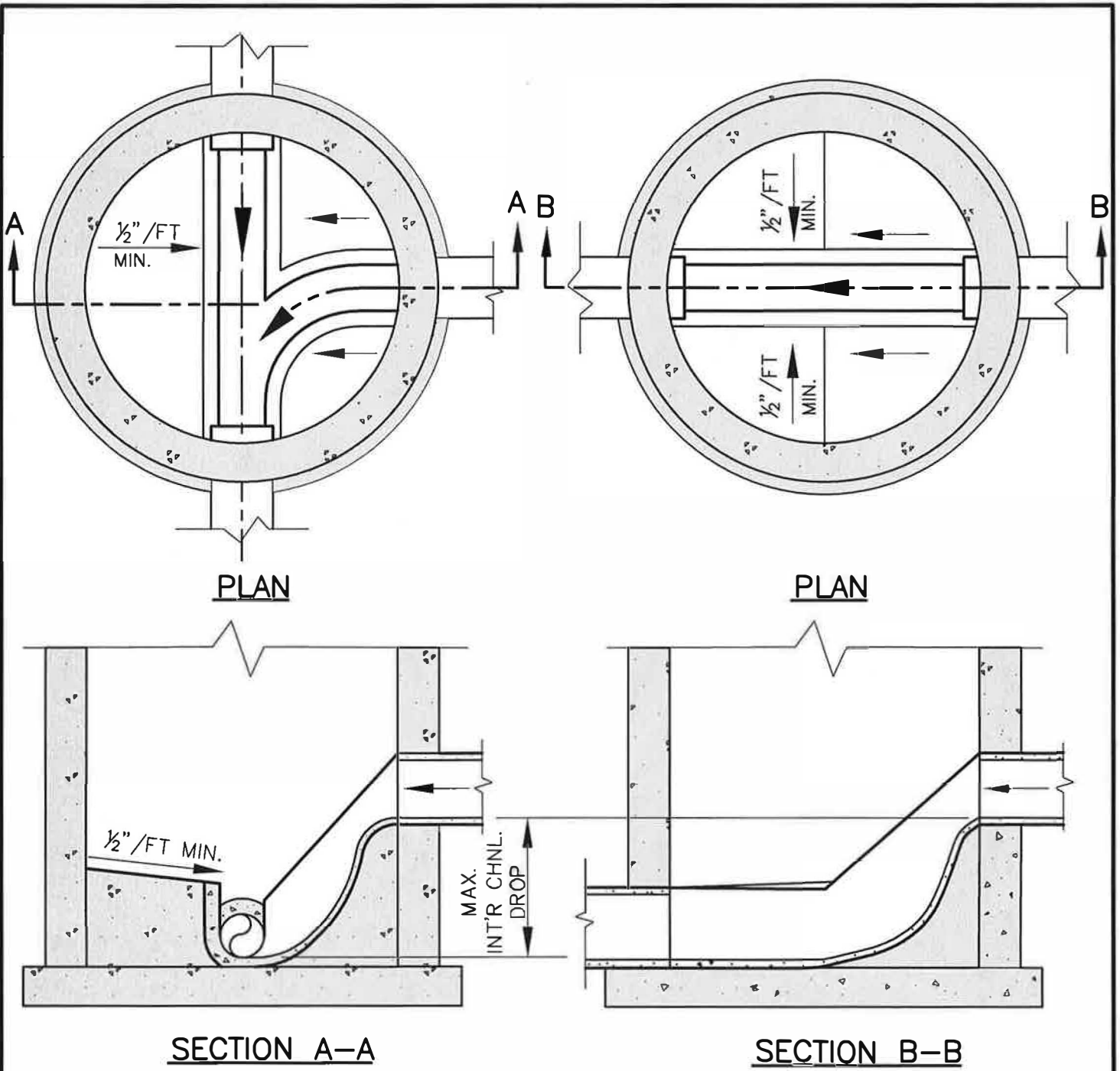

MANHOLE I.D. INCHES	MAX. INT'R CHNL. DROP INCHES
48	18
54	22
72	30
96	40

APPROVED BY

 DIRECTOR, ENGINEERING SERVICES TOM L. ARNOLD, P.E.

 PRINCIPAL ENGINEER, DESIGN GARY S. NELSON, P.E.

ADOPTED: 2/86
 REVISED: 05/2007
 SUPERSEDES: 12/98
 CHECKED BY: JAG
 SCALE: NTS
 DWG/REV. BY: DGB/MDH

MANHOLE - INTERIOR CHANNEL DROP
 ENGINEERING SERVICES
 CITY OF SPOKANE, WASHINGTON
 STANDARD PLAN No. Z-110

DROP CHANNEL TO BE ALIGNED W/ DIRECTION OF SEWER CHANNEL FLOW

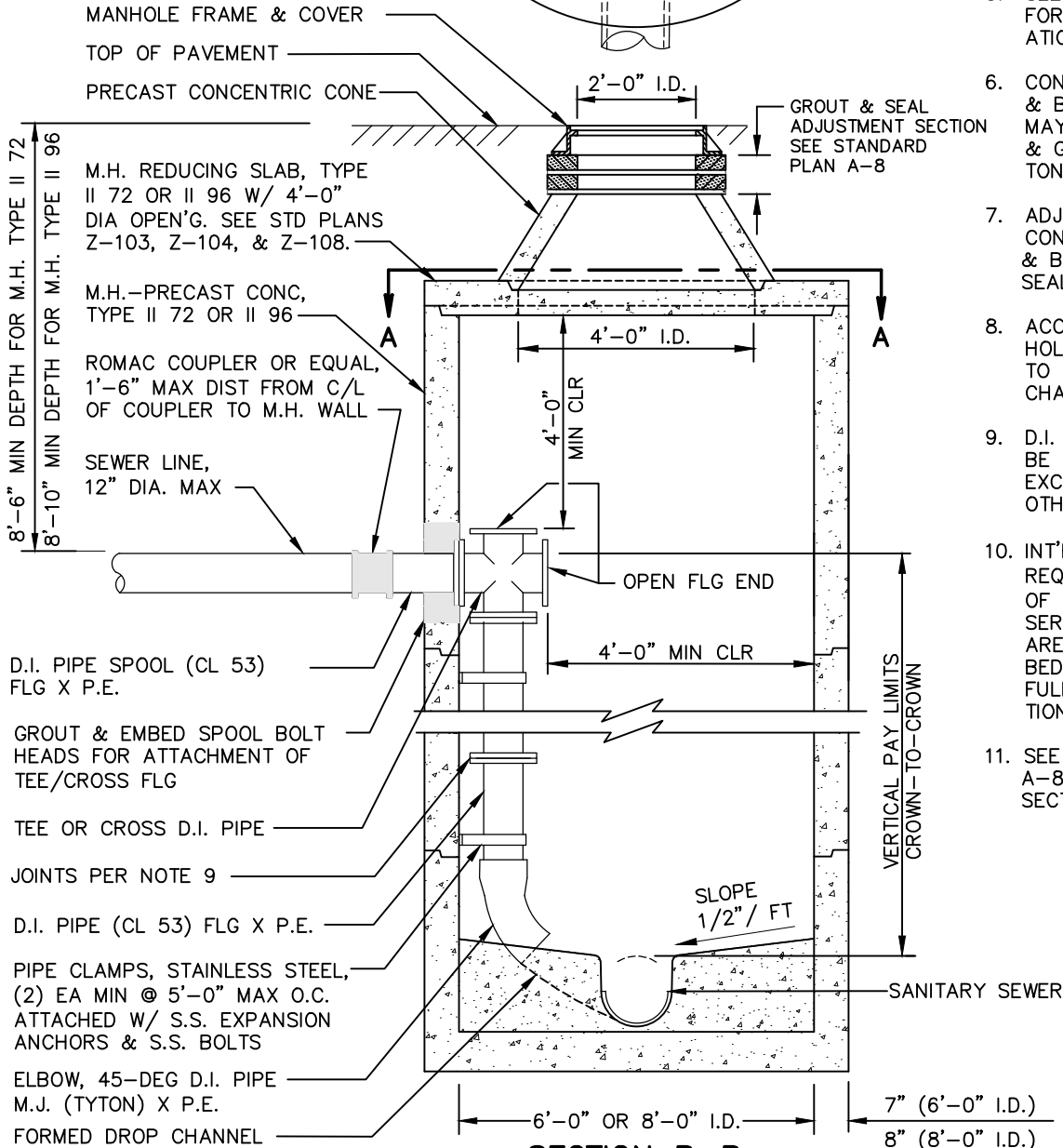
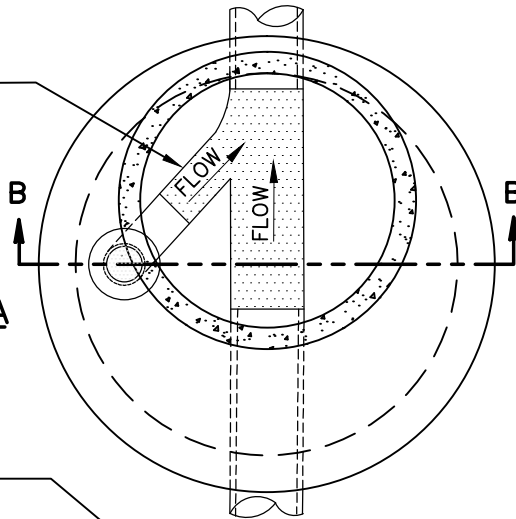
SECTION A-A



SECTION B-B

NOTES:

1. SEE SECTIONS 7-05 & 9-12.4 FOR PRECAST CONCRETE MANHOLES.
2. SEE STD PLANS A-12 & A-13 FOR MANHOLE FRAME & COVER.
3. SEE STD PLAN Z-108 FOR MANHOLE REDUCING SLABS.
4. SEE STD PLAN Z-109 FOR MANHOLE STEP DETAILS.
5. SEE STD PLAN Z-118 FOR BASE & FOUNDATION DETAILS.
6. CONE, REDUCING SLAB & BARREL JOINTS MAY BE EITHER TONGUE & GROOVE OR REVERSE TONGUE & GROOVE.
7. ADJUSTMENT SECTION, CONE, REDUCING SLAB & BARREL JOINTS TO BE SEALED PER SEC 7-05.3.
8. ACCESS HOLES OF MANHOLE & REDUCING SLAB TO BE CENTERED OVER CHANNEL.
9. D.I. PIPE JOINTS SHALL BE FLANGE JOINTS, EXCEPT AS NOTED OTHERWISE.
10. INT'R DROPS SHALL REQ'D THE APPROVAL OF THE CITY ENGR SERVICES DEPT. DROPS ARE UTILIZED WHERE BEDROCK PREVENTS FULL-DEPTH EXCAVATION.
11. SEE STANDARD PLAN A-8 FOR ADJUSTMENT SECTION REQUIREMENTS.

APPROVED BY

[Signature]
 ENGINEERING SERVICES DIRECTOR
 KYLE TWHIG
 CITY ENGINEER
 DAN BULLER, P.E.

ADOPTED: _____
 REVISED: 10/2019
 SUPERSEDES: 01/2017
 CHECKED BY: JAG
 SCALE: NTS
 DWG/REV. BY: MDH/TSS

MANHOLE-INTERIOR D.I.P. DROP



ENGINEERING SERVICES
 CITY OF SPOKANE, WASHINGTON

STANDARD
 PLAN No.
Z-111

DROP CHANNEL TO BE ALIGNED W/ DIRECTION OF SEWER CHANNEL FLOW. SHAPE CHANNEL TO PROVIDE SMOOTH SWEEPING TRANSITION.

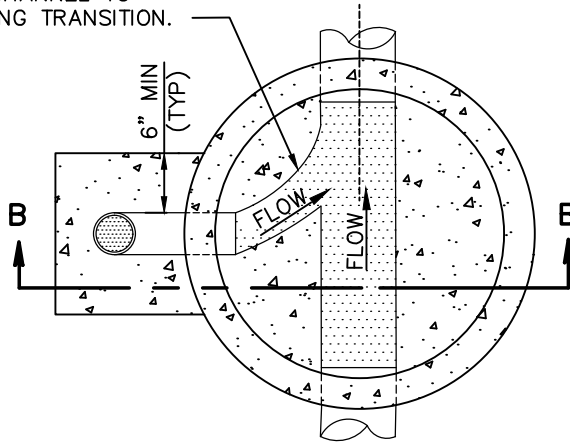

SECTION A-A

NOTES:

1. SEE SECS 7-05 & 9-12.4 FOR PRECAST CONCRETE MANHOLES.
2. SEE STD PLANS A-12 & A-13 FOR MANHOLE FRAME & COVER.
3. SEE STD Z-109 FOR MANHOLE STEP DETAILS.
4. SEE STD PLAN Z-118 FOR BASE & FOUNDATION DETAILS.
5. CONE & BARREL JOINTS MAY BE EITHER TONGUE & GROOVE OR REVERSE TONGUE & GROOVE.
6. ADJUSTMENT SECTION, CONE & BARREL JOINTS TO BE SEALED PER SEC 7-05.3.
7. ACCESS HOLE TO BE CENTERED OVER CHANNEL.
8. D.I. PIPE JOINTS SHALL BE MECHANICAL JOINTS.
9. EXT'R PIPE DROPS SHALL REQUIRE THE APPROVAL OF THE CITY ENGR SERVICES DEPT. DROPS ARE UTILIZED WHERE BEDROCK PREVENTS FULL-DEPTH EXCAVATION.
10. GROUT ENTIRE CIRCUMFERENCE OF PIPE ANNULUS AROUND PIPE PENETRATION.
11. SEE STANDARD PLAN A-8 FOR ADJUSTMENT SECTION REQUIREMENTS.

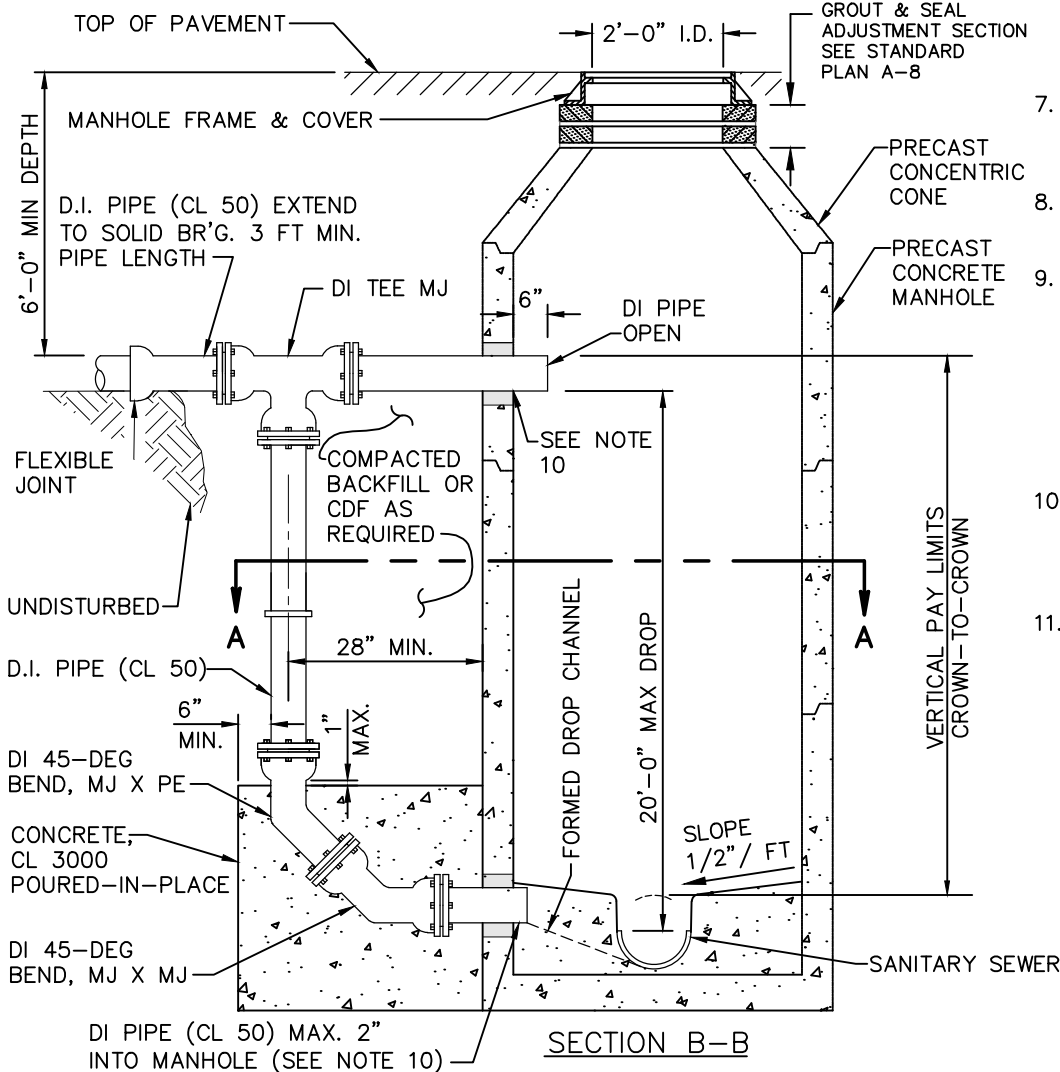

SECTION B-B

APPROVED BY

[Signature]
 ENGINEERING SERVICES DIRECTOR
 KYLE TWHIG
 CITY ENGINEER
 DAN BULLER, P.E.

ADOPTED: _____
 REVISED: 10/2019
 SUPERSEDES: 01/2017
 CHECKED BY: JAG
 SCALE: NTS
 DWG/REV. BY: MDH/MLD

MANHOLE - EXTERIOR D.I.P. DROP



ENGINEERING SERVICES
 CITY OF SPOKANE, WASHINGTON

STANDARD
 PLAN No.
Z-112

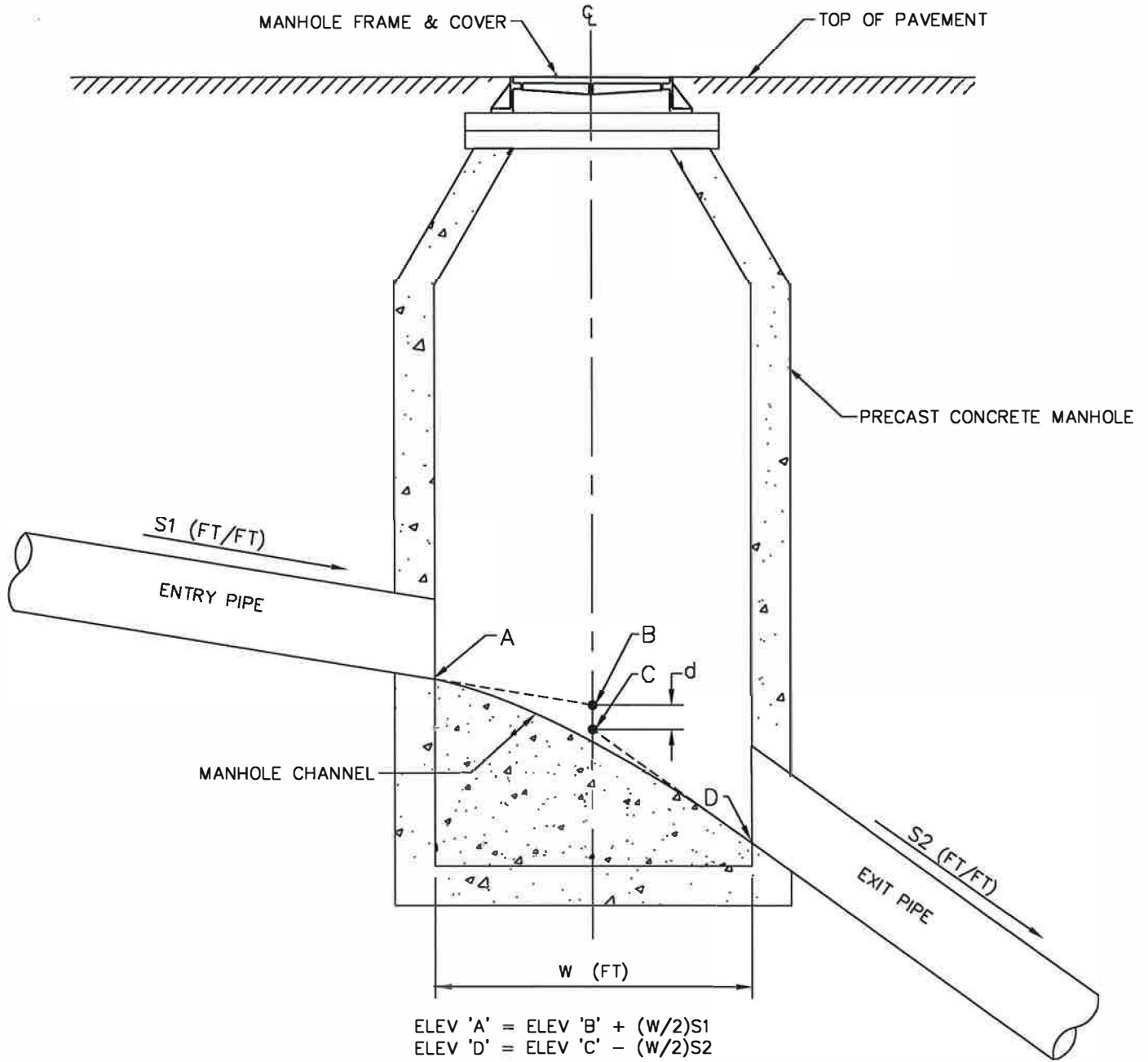

NOTES:

1. ELEV 'A' IS THE INVERT ELEVATION OF THE ENTRY PIPE @ THE MANHOLE WALL ON GRADE S1.
2. ELEV'S 'B' & 'C' ARE THE DESIGN INVERT ELEVATIONS OF THE ENTRY/EXIT PIPES @ THE MANHOLE C/L.
3. ELEV 'D' IS THE INVERT ELEVATION OF THE EXIT PIPE @ THE MANHOLE WALL ON GRADE S2.
4. DIMENSION 'd' IS THE REQ'D MIN CHANNEL DROP PER DESIGN STD 4.2-6.
5. SEE STD PLANS Z-110, Z-111, & Z-112 FOR CHANNEL DROPS IN EXCESS OF THE MIN DROP.

APPROVED BY

Thomas J. Arnold
 DIRECTOR, ENGINEERING SERVICES TOM L. ARNOLD, P.E.
K. Brown
 PRINCIPAL ENGINEER, DESIGN KEN M. BROWN, P.E.

ADOPTED: 4/2004
 REVISED:
 SUPERSEDES: Z-111 12/98
 SCALE: NTS
 DWG/REV. BY: MDH/TSS

MANHOLE - PIPE INVERT ELEVATIONS



ENGINEERING SERVICES
 CITY OF SPOKANE, WASHINGTON

STANDARD
 PLAN No.
 Z-113

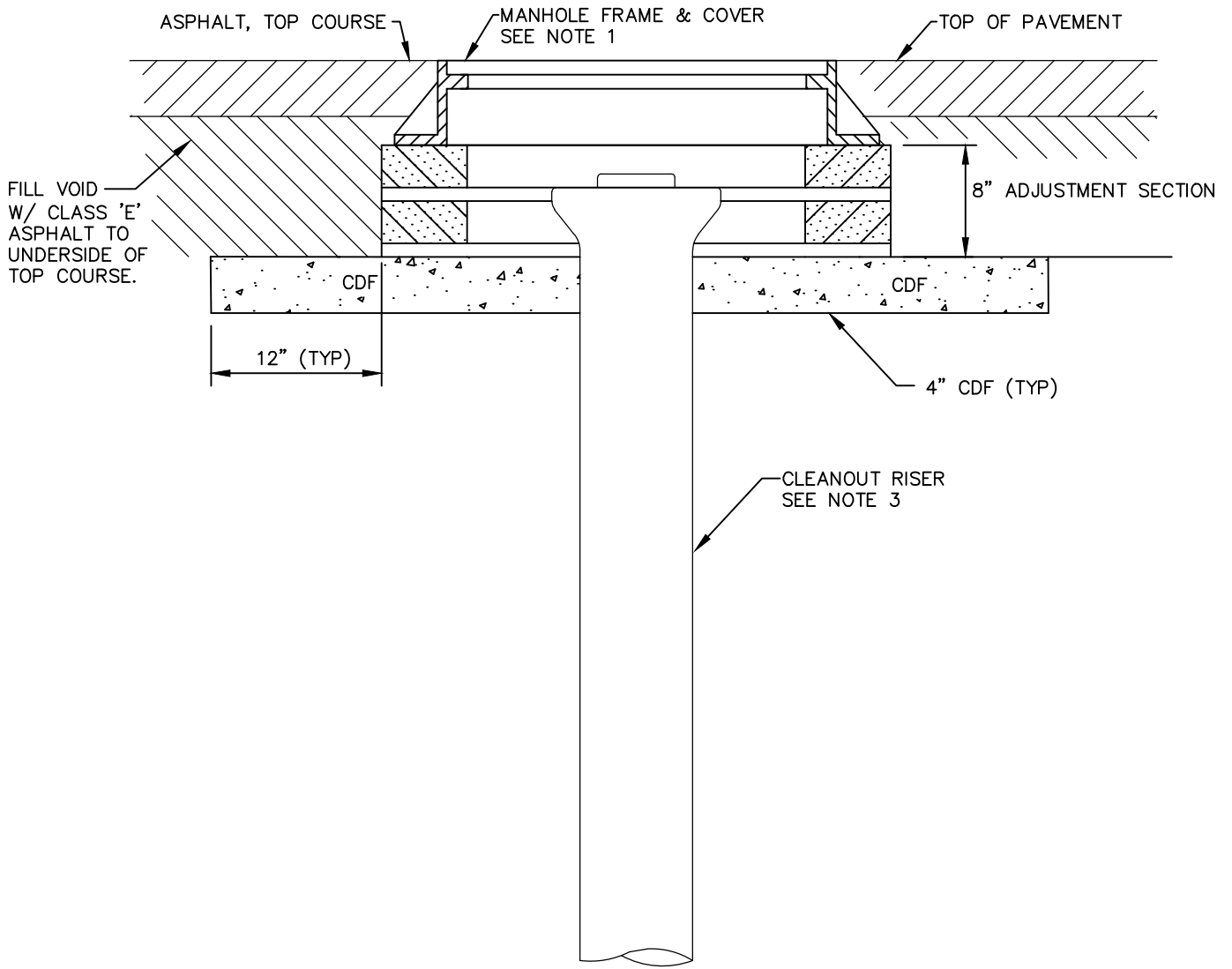

NOTES:

1. SEE STD PLANS A-12 & A-13 FOR MANHOLE FRAME & COVER.
2. ACCESS HOLE TO BE CENTERED OVER CLEANOUT.
3. TOP OF CLEANOUT SHALL EXTEND TO A POINT NOT LESS THAT 6" NOR MORE THAN 12" BELOW TOP OF MANHOLE COVER. CLEANOUTS SHALL BE PLUGGED W/ A REMOVABLE STOPPER WHICH SHALL PREVENT PASSAGE OF DIRT OR WATER.

<p style="text-align: center;">APPROVED BY</p> <p style="text-align: center;">ENGINEERING SERVICES DIRECTOR KYLE TWOHIG</p> <p style="text-align: center;">CITY ENGINEER DAN BULLER, P.E.</p>	<p>ADOPTED: _____</p> <p>REVISED: 10/2019</p> <p>SUPERSEDES: 4/2004</p> <p>SCALE: NTS</p> <p>DWG/REV. BY: TSS</p>	<p>SEWER CLEANOUT</p>
		<p>ENGINEERING SERVICES CITY OF SPOKANE, WASHINGTON</p>
		<p>STANDARD PLAN No. Z-114</p>

SEE STANDARD PLAN Z-116 FOR REQUIREMENTS FOR USE OR TEE OR WYE RISER CONNECTIONS.

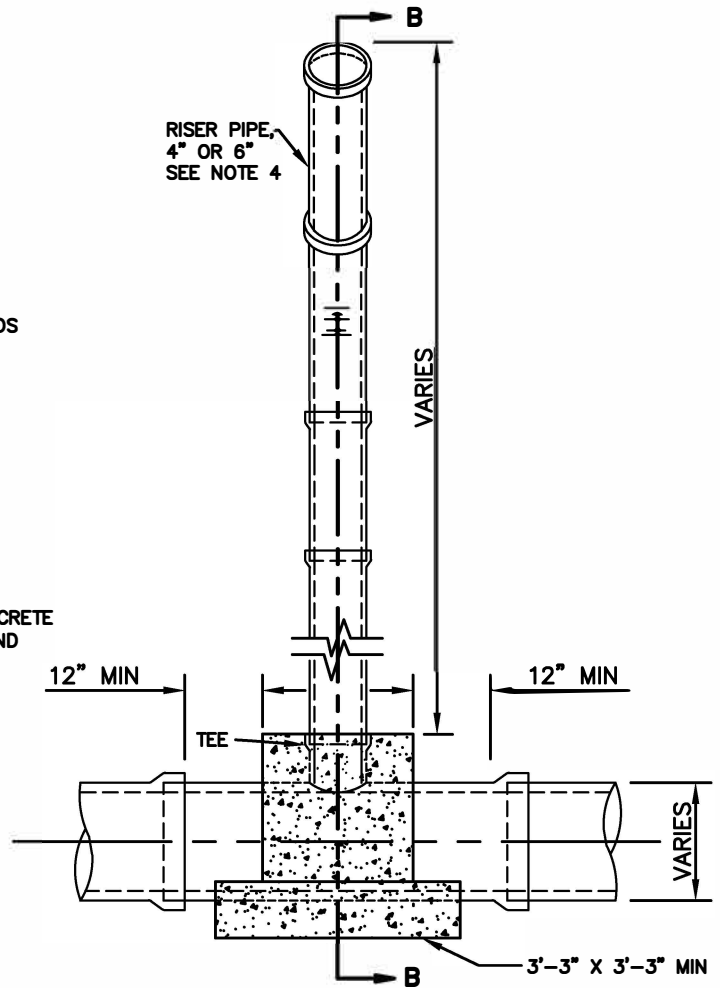
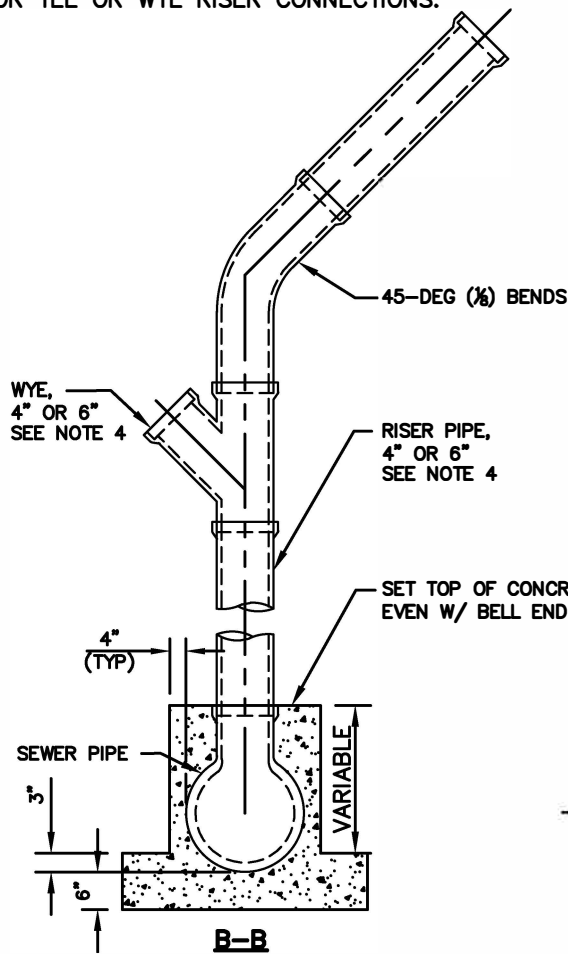

NOTES:

1. SEE SEC 7-17 FOR SANITARY SEWER PIPE.
2. SEE DESIGN STANDARD 4.3 FOR SIDE-SEWERS.
3. CONCRETE SHALL BE CLASS 3000 PER SEC 6-02.
4. A MAX OF (2) SIDE-SEWER BRANCHES ARE ALLOWED OFF A VERTICAL RISER. SIDE-SEWER BRANCHES SHALL BE NO LARGER THAN THE SIZE OF THE VERTICAL RISER. VERTICAL RISER SHALL BE MAX 6" DIAMETER PIPE.
5. USE OF THIS RISER CONNECTION IS FOR SPECIAL CONDITIONS ONLY AND REQUIRES PRIOR APPROVAL OF THE CITY ENGINEER.

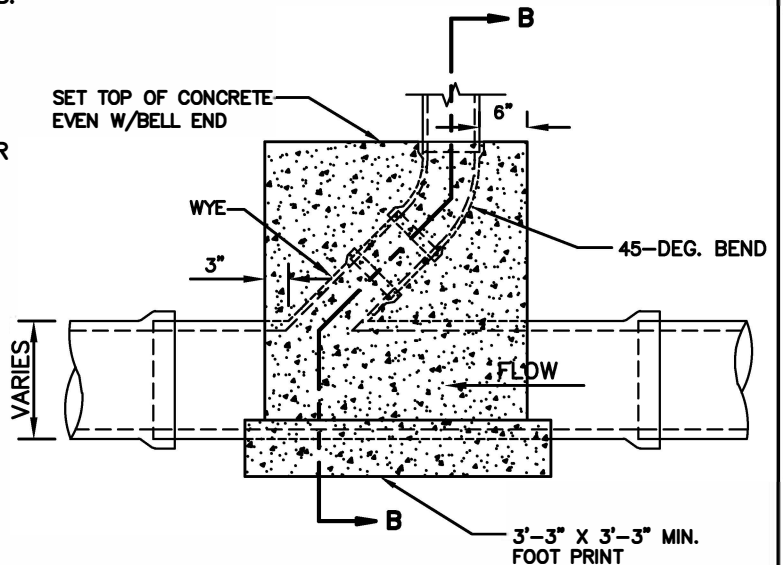

APPROVED BY

 ENGINEERING OPERATIONS MANAGER KYLE TWOHIG

 CITY ENGINEER DANIEL ALBERT BULLER, P.E.

ADOPTED: 4/2004
 REVISED: 02/2018
 SUPERSEDES: 04/2013
 SCALE: NTS
 REVISED BY: MDH/MLD

**SIDE-SEWER
 RISER CONNECTION**

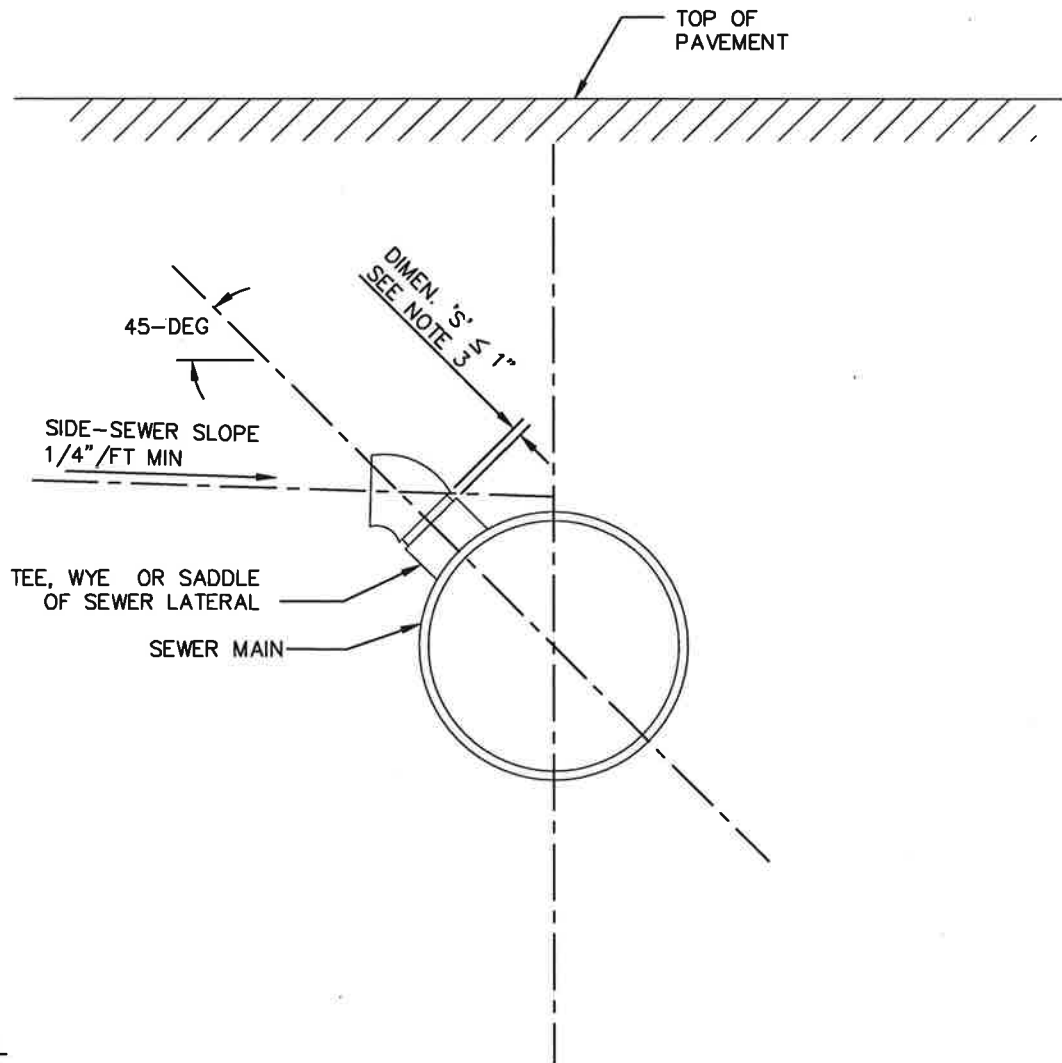

ENGINEERING SERVICES
 CITY OF SPOKANE, WASHINGTON

STANDARD
 PLAN No.
Z-115



NOTES:

1. SEE DESIGN STANDARD 4.3 FOR SIDE-SEWERS.
2. RESIDENTIAL AREAS REQUIRE A 4" MIN SIDE-SEWER STUB. COMMERCIAL AREAS REQUIRE A 6" MIN SIDE-SEWER STUB.
3. DIMENSION 'S' MAY BE INCREASED TO PROVIDE A DESIRED SIDE-SEWER DEPTH @ PROPERTY LINE, IF APPROVED BY THE CITY ENGINEER.
4. THE FIRST SIDE SEWER CONNECTION OF ANY SIZE (4" OR 6") DOWNSTREAM OF AN END OF RUN MANHOLE SHALL BE A WYE CONNECTION.
5. FOR OTHER 4" SIDE SEWER CONNECTIONS, TEES OR WYES MAY BE USED TO CONSTRUCT SIDE SEWER CONNECTIONS.
6. ONLY WYE CONNECTIONS SHALL BE USED FOR 6" SIDE SEWERS CONNECTING TO SEWER MAINS UP TO AND INCLUDING 21" DIAMETER.
7. TEES OR WYES ARE ALLOWED FOR 6" SIDE SEWER CONNECTIONS TO SEWER MAINS LARGER THAN 21" DIAMETER.

<p style="text-align: center;">APPROVED BY</p> <div style="display: flex; justify-content: space-between;"> <div style="text-align: center;">  <small>ENGINEERING OPERATIONS MANAGER</small> <small>CITY ENGINEER</small> </div> <div style="text-align: center;"> <small>KYLE TWOHIG</small>  <small>DANIEL ALBERT BULLER, P.E.</small> </div> </div>	<p>ADOPTED: 4/2004 REVISED: 01/2017 SUPERSEDES: 4/2013 SCALE: NTS DWG/REV. BY: PCF/MLD</p>	<p>SIDE-SEWER TYPICAL CONNECTION</p>		<p>ENGINEERING SERVICES CITY OF SPOKANE, WASHINGTON</p>	<p>STANDARD PLAN No. Z-116</p>
--	--	---	---	---	---

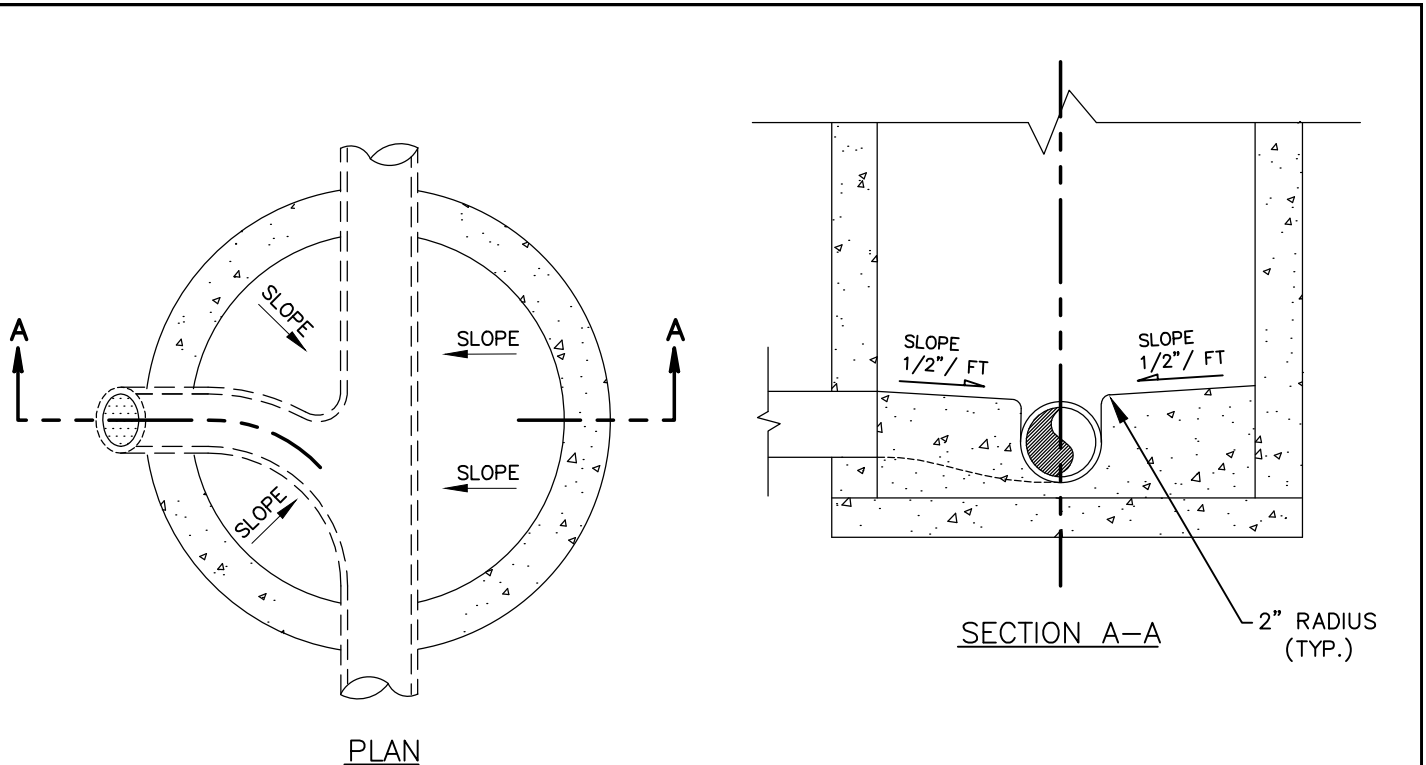

GENERAL NOTES:

1. THE SHELF AND CHANNEL SHALL HAVE A SMOOTH FINISH
2. CONSTRUCT SHELF TO THE CROWN LINE OF PIPE
3. SLOPE BENCHES 1:24

QUADRANT NOTES:

- 1 NO SEWER PIPE (CENTERLINE) SHALL ENTER MANHOLE IN QUADRANT III & IV
- 2 EXCEPT FOR A MANHOLE INLET 180° FROM THE CENTERLINE OF ANY CHANNEL ENTERING IN QUADRANT I OR II SHALL BE A SMOOTH, CONTINUOUS ARC THAT IS A TANGENT TO THE CENTERLINE OF THE OUTLET PIPE AT OUTLET MANHOLE WALL
- 3 MINIMUM RADIUS OF ANY MANHOLE CHANNEL CENTERLINE SHALL BE EQUAL TO THE MANHOLE INSIDE DIAMETER

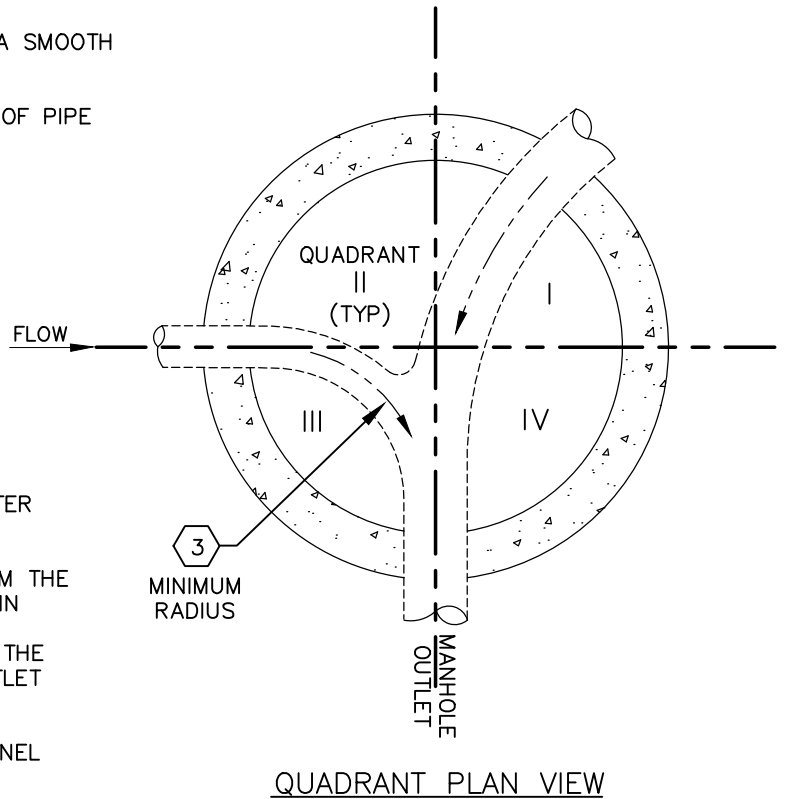

<p style="text-align: center;">APPROVED BY</p> <p style="text-align: center; font-size: small;">ENGINEERING SERVICES DIRECTOR KYLE TWOHIG</p> <p style="text-align: center; font-size: small;">CITY ENGINEER DAN BULLER, P.E.</p>	<p>ADOPTED: <u>02/2019</u></p> <p>REVISED: _____</p> <p>SUPERSEDES: _____</p> <p>CHECKED BY: _____ WRP</p> <p>SCALE: _____ NTS</p> <p>REVISED BY: _____ CDJ</p>	<p>MANHOLE CHANNEL DETAIL – TYPICAL</p> <p>ENGINEERING SERVICES CITY OF SPOKANE, WASHINGTON</p>	<p>STANDARD PLAN No. Z-117</p>
---	---	--	---

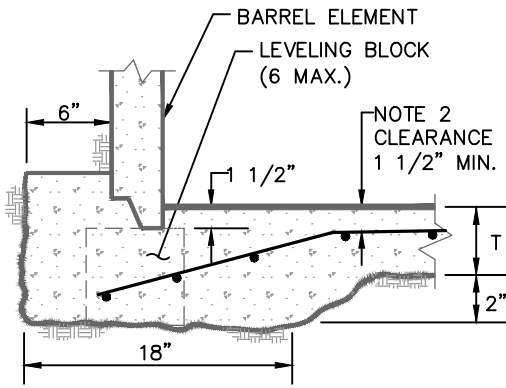

CAST IN PLACE BASE SLAB
(CAST AROUND BARREL)

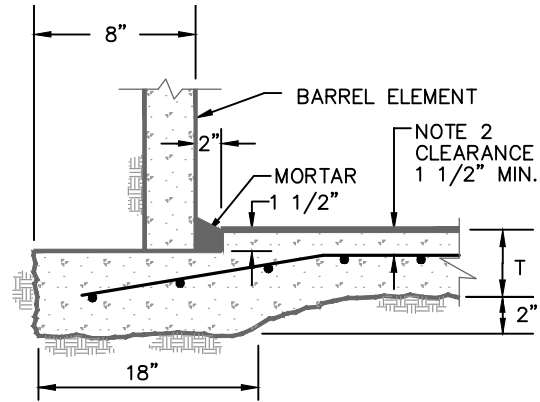

CAST IN PLACE BASE SLAB
(SEPARATE FROM BARREL)

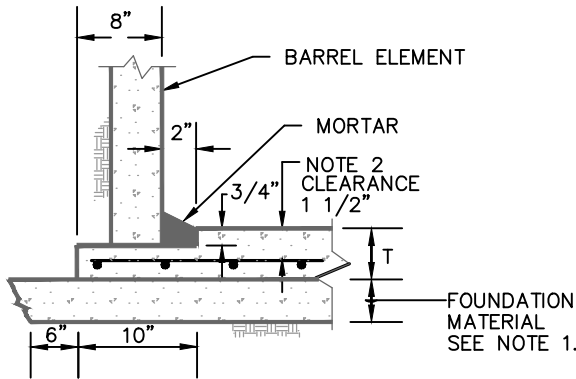

PRECAST BASE SLAB

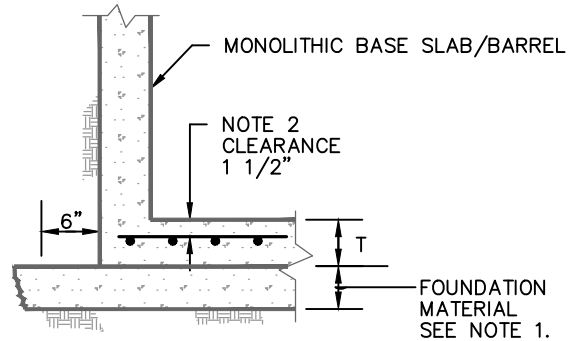

**PRECAST MONOLITHIC
BASE SLAB / BARREL**

GENERAL NOTES:

1. 6" MINIMUM COMPACTED DEPTH OF BEDDING MATERIAL MEETING THE REQUIREMENTS OF THE SPECIAL PROVISIONS, OR 4" OF GROUT AS DIRECTED BY THE ENGINEER. COMPACT BEDDING MATERIAL TO 92%, MINIMUM.
2. SEE SCHEDULE FOR BASE SLAB REINFORCEMENT.
3. SEE PLAN B-102C BASE DETAILS FOR DRYWELLS

BASE SLAB MINIMUM REINFORCEMENT SCHEDULE			
BARREL SIZE	T	METHOD OF SLAB CONSTRUCTION	
		PRECAST OR CAST-IN-PLACE	MONOLITHIC SLAB & BARREL
≤ 48"	6"	#4 @ 10" E.W.	#4 @ 10" E.W.
54"	8"	#4 @ 12" E.W.	#4 @ 12" E.W.
72"	8"	#4 @ 6 1/2" E.W.	#4 @ 10" E.W.
96"	12"	#4 @ 6" E.W.	#4 @ 8" E.W.

APPROVED BY

Katy Allen
DIRECTOR, ENGINEERING SERVICES KATY D. ALLEN, P.E.
Jim R. Smith
PRINCIPAL ENGINEER, DESIGN JIM R. SMITH, P.E.

ADOPTED: 2/90
REVISED: 12/98
SUPERSEDES: 7/91

SCALE: N.T.S.
DWG./REV. BY: REP

**CATCH BASIN, DRYWELL & MANHOLE
BASE SLAB AND FOUNDATION DETAILS**



ENGINEERING SERVICES
CITY OF SPOKANE, WASHINGTON

STANDARD
PLAN No.
Z-118