



Spokane Plan Commission Agenda

Wednesday, June 12, 2024

2:00 PM

Hybrid - Council Briefing Center / Teams
808 W Spokane Falls Blvd, Spokane, WA 99201

Virtual Meeting Link - See Below For Information

TIMES GIVEN ARE AN ESTIMATE AND ARE SUBJECT TO CHANGE

Commission Briefing Session:

2:00 – 2:20	<ol style="list-style-type: none"> 1. Approve 5/22/2024 meeting minutes 2. City Council Liaison Report 3. Community Assembly Liaison Report 4. President Report 5. Transportation Sub-Committee Report 6. Secretary Report 7. Approval of current agenda 	<p>All CM Kitty Klitzke Mary Winkes Greg Francis Mary Winkes Spencer Gardner</p>
-------------	---	--

Workshops:

2:20 – 3:15	<ol style="list-style-type: none"> 1. South Logan TOD Implementation Drafts (SMC 17A.20.160, 17C.111.205, 17C.111.230, 17C.111.420, 17C.120.220, 17C.122, 17C.122T, 17C.123, 17C.230, 17C.300, 17C.415) 	<p>KayCee Downey</p>
3:15 – 3:45	<ol style="list-style-type: none"> 2. Comp Plan Amendment Z24-105COMP Workshop 	<p>KayCee Downey</p>

Public Comment Period:

Citizens are invited to address the Plan Commission on any topic not on the agenda.

Adjournment: The next PC meeting will be held on Wednesday, June 26, 2024

AMERICANS WITH DISABILITIES ACT (ADA) INFORMATION: The City of Spokane is committed to providing equal access to its facilities, programs and services for persons with disabilities. The Council Briefing Center in the lower level of Spokane City Hall, 808 W. Spokane Falls Blvd., is wheelchair accessible and also is equipped with an infrared assistive listening system for persons with hearing loss. Headsets may be checked out (upon presentation of picture I.D.) through the meeting organizer. Individuals requesting reasonable accommodations or further information may call, write, or email Risk Management at 509.625.6221, 808 W. Spokane Falls Blvd, Spokane, WA, 99201; or m_lowmaster@spokanecity.org. Persons who are deaf or hard of hearing may contact Risk Management through the Washington Relay Service at 7-1-1. Please contact us forty-eight (48) hours before the meeting date.

Plan Commission Meeting Information

Wednesday, June 12, 2024

Plan Commission will be held in a hybrid in-person / virtual format. Members of the public are welcome to attend in person at City Hall or online using the following information.

Microsoft Teams [Need help?](#)

Microsoft Teams meeting

Join on your computer, mobile app, or room device.

[Click here to join the meeting](#)

Meeting ID:
213 698 980 677

Meeting ID: 213 698 980 677

Passcode: BgoP4d

Passcode:
BgoP4d

[Download Teams](#) | [Join on the web](#)

Join with a video conferencing device.

cityofspokane@m.webex.com

Video Conference ID: 116 540 092 1

[Alternate VTC instructions](#)

Or call in (audio only)

+1 323-618-1887,,215215222# United States, Los Angeles

Phone Conference ID: 215 215 222#

[Find a local number](#) | [Reset PIN](#)

[Learn More](#) |

No Hearings

Please note that public comments will be taken during the meeting, but the public is encouraged to continue to submit their comments or questions in writing to:

plancommission@spokanecity.org

The audio proceedings of the Plan Commission meetings will be recorded and are available online.

AMERICANS WITH DISABILITIES ACT (ADA) INFORMATION: The City of Spokane is committed to providing equal access to its facilities, programs and services for persons with disabilities. The Council Briefing Center in the lower level of Spokane City Hall, 808 W. Spokane Falls Blvd., is wheelchair accessible and also is equipped with an infrared assistive listening system for persons with hearing loss. Headsets may be checked out (upon presentation of picture I.D.) through the meeting organizer. Individuals requesting reasonable accommodations or further information may call, write, or email Risk Management at 509.625.6221, 808 W. Spokane Falls Blvd, Spokane, WA, 99201; or mlovmaster@spokanecity.org. Persons who are deaf or hard of hearing may contact Risk Management through the Washington Relay Service at 7-1-1. Please contact us forty-eight (48) hours before the meeting date.

Plan Commission Meeting Information

Wednesday, June 12, 2024

Plan Commission will be held in a hybrid in-person / virtual format. Members of the public are welcome to attend in person at City Hall or online using the following information.

Microsoft Teams

Join on your computer, mobile app or room device

[Click here to join the meeting](#)

Meeting ID: 213 698 980 677

Passcode: BgoP4d

Meeting ID:

[Download Teams](#) | [Join on the web](#)

213 698 980 677

Join with a video conferencing device

Passcode: BgoP4d

cityofspokane@m.webex.com

Video Conference ID: 116 540 092 1

[Alternate VTC instructions](#)

Or call in (audio only)

[+1 323-618-1887](tel:+13236181887).,215215222# United States, Los Angeles

Phone Conference ID: 215 215 222#

[Find a local number](#) | [Reset PIN](#)

Please note that public comments will be taken during the meeting, but the public is encouraged to continue to submit their comments or questions in writing to: plancommission@spokanecity.org

The audio proceedings of the Plan Commission meetings will be recorded and are available online.

AMERICANS WITH DISABILITIES ACT (ADA) INFORMATION: The City of Spokane is committed to providing equal access to its facilities, programs and services for persons with disabilities. The Council Briefing Center in the lower level of Spokane City Hall, 808 W. Spokane Falls Blvd., is wheelchair accessible and also is equipped with an infrared assistive listening system for persons with hearing loss. Headsets may be checked out (upon presentation of picture I.D.) through the meeting organizer. Individuals requesting reasonable accommodations or further information may call, write, or email Risk Management at 509.625.6221, 808 W. Spokane Falls Blvd, Spokane, WA, 99201; or mlovmaster@spokanecity.org. Persons who are deaf or hard of hearing may contact Risk Management through the Washington Relay Service at 7-1-1. Please contact us forty-eight (48) hours before the meeting date.

Plan Commission & Committees

Upcoming Agenda Items

June 26, Plan Commission (90 minutes available) Hybrid		
Housing Work Group		
1:00 – 1:30		
Workshop		
Time	Item	Presenter
2:00 – 2:20	Meeting Briefing	Plan Commission
2:20 – 2:50	CPA Z23-474COMP (Mission & Sinto) Workshop	Brandon Whitmarsh
2:50 – 3:20	CPA Z23-476COMP (8 th Avenue) Workshop	Brandon Whitmarsh
3:20 – 3:45	Introduction to Citywide CIP	Jessica Stratton and Kevin Freibott
3:45 – 4:00	Transition to Chambers	
Hearing Items		
Time	Item	Presenter
	South Logan TOD Implementation (SMC 17A.20.160, 17C.111.205, 17C.111.230, 17C.111.420, 17C.120.220, 17C.122, 17C.122T, 17C.123, 17C.230, 17C.300, 17C.415)	KayCee Downey

July 2 – PCTS (Hybrid)		
Time	Item	Presenter
9:00 am – 9:30 am	CANCELLED	PCTS

July 10, Plan Commission (90 minutes available) Hybrid		
Housing Work Group		
1:00 – 1:30		
Workshop		
Time	Item	Presenter
2:00 – 2:20	Meeting Briefing	Plan Commission
2:20 – 2:50	CPA Z23-477COMP (Bemis & Rustle) Workshop	Kevin Freibott
2:50 – 3:20	CPA Z23-478COMP (Assembly & Bemis) Workshop	Kevin Freibott
3:45 – 4:00	Transition to Chambers	
Hearing Items		

AMERICANS WITH DISABILITIES ACT (ADA) INFORMATION: The City of Spokane is committed to providing equal access to its facilities, programs and services for persons with disabilities. The Council Briefing Center in the lower level of Spokane City Hall, 808 W. Spokane Falls Blvd., is wheelchair accessible and also is equipped with an infrared assistive listening system for persons with hearing loss. Headsets may be checked out (upon presentation of picture I.D.) through the meeting organizer. Individuals requesting reasonable accommodations or further information may call, write, or email Risk Management at 509.625.6221, 808 W. Spokane Falls Blvd, Spokane, WA, 99201; or mlovmaster@spokanecity.org. Persons who are deaf or hard of hearing may contact Risk Management through the Washington Relay Service at 7-1-1. Please contact us forty-eight (48) hours before the meeting date.

July 24, Plan Commission (90 minutes available) Hybrid		
Housing Work Group		
1:00 – 1:30		
Workshop		
Time	Item	Presenter
2:00 – 2:20	Meeting Briefing	Plan Commission
2:20 – 2:50	CPA Z23-479COMP (N Indian Trail) Workshop	Kevin Freibott
2:50 – 3:20	Comp Plan Amendment Workshop Wrap-Up	Kevin Freibott
3:45 – 4:00	Transition to Chambers	
Hearing Items		

AMERICANS WITH DISABILITIES ACT (ADA) INFORMATION: The City of Spokane is committed to providing equal access to its facilities, programs and services for persons with disabilities. The Council Briefing Center in the lower level of Spokane City Hall, 808 W. Spokane Falls Blvd., is wheelchair accessible and also is equipped with an infrared assistive listening system for persons with hearing loss. Headsets may be checked out (upon presentation of picture I.D.) through the meeting organizer. Individuals requesting reasonable accommodations or further information may call, write, or email Risk Management at 509.625.6221, 808 W. Spokane Falls Blvd, Spokane, WA, 99201; or mlovmaster@spokanecity.org. Persons who are deaf or hard of hearing may contact Risk Management through the Washington Relay Service at 7-1-1. Please contact us forty-eight (48) hours before the meeting date.

Spokane Plan Commission - Draft Minutes

Wednesday, May 22, 2024

Teams Teleconference

Meeting Minutes: Plan Commission Workshop called to order at 2:00 pm by President Greg Francis.

Attendance for Plan Commission Workshop:

- Board Members Present: Greg Francis (President), Ryan Patterson (Vice President), Tim Williams, Sandra Neperud, Carole Shook, Jesse Bank
- Board Members Not Present: *None*
- Non-Voting Members Present: Kitty Klitzke (Council Member Liaison), Mary Winkes (Community Assembly Liaison)
- Non-Voting Members Not present: *None*
- *Quorum Present: Yes*
- Staff Members Present: Spencer Gardner, Angie McCall, KayCee Downey, Brandon Whitmarsh, Kevin Freibott, Tim Thompson, Amanda Beck, Kevin Picanco, Inga Note

Public Comment: Citizens are invited to address the Plan Commission on any topic not on the agenda. 3 Minutes each.

None

Minutes: Minutes from 5/8/2024 approved unanimously.

Briefing Session:

- **City Council Liaison Report - CM Kitty Klitzke**
 - Council Member Klitzke reported that the moratorium on new plat applications that Council passed could have a lot of implications for the Plan Commission. She stated that there needs to be an understanding of the scope of the problem (including but not limited to evacuation routes, density, street designs, modeling).
- **Community Assembly Liaison Report - Mary Winkes**

No report at this time as they did not meet.
- **Commission President Report - Greg Francis**
 - President Greg Francis reported that he appreciated that Commissioner Neperud informed the group that she will not be here for the June 26th meeting. Since there is such a low number of Plan Commissioners currently and we are in danger of losing quorum and hearings, please attempt to avoid missing meetings if possible.
- **Transportation Subcommittee Report - Mary Winkes**

No report at this time as they did not meet.
- **Secretary Report - Spencer Gardner**
 - Spencer Gardner reminded the group that there is a Hearing today on the Six-Year Streets Plan. Another reminder that there is an expected Hearing on June 26th for the South Logan plan.
 - Council adopted a moratorium on new plat applications (the Grandview Thorpe and Latah area).
 - It has been customary to cancel one Plan Commission meeting in August (typically the second meeting in August). This year we are planning on cancelling the first meeting in August (the 14th) due to accommodating the Growth Management Hearing Board.

Current Agenda: The current agenda was approved unanimously.

Workshop(s):

- South Logan TOD Implementation Drafts (SMC 17A.20.160, 17C.111.205, 17C.111.230, 17C.111.420, 17C.120.220, 17C.122, 17C.122T, 17C.123, 17C.230, 17C.300, 17C.415)
 - Presentation provided by staff member KayCee Downey.
 - Questions asked and answered.
 - Discussion ensued.
- Introduction to 2024 Comprehensive Plan Amendment Docket
 - Presentation provided by staff member Kevin Freibott.
 - Questions asked and answered.
 - Discussion ensued.
- Introduction, Update to 17D.075, Transportation Impact Fees
 - Presentation provided by Inga Note.
 - Questions asked and answered.
 - Discussion ensued.

Workshop Adjourned at 3:35 PM.

Hearing Commenced at 4:00 PM.

Attendance for Plan Commission Hearing:

- Board Members Present: Greg Francis (President), Ryan Patterson (Vice President), Tim Williams, Sandra Neperud, Carole Shook, Jesse Bank
- Board Members Not Present: *None*
- Non-Voting Members Present: Mary Winkes (Community Assembly Liaison)
- *Quorum Present: Yes*
- Six-Year Street Plan Update
 - Presentation provided by Kevin Picanco.
 - Questions asked and answered.
 - Discussion ensued.
 - **Motion: I [VP Ryan Patterson] move that we recommend the update to the Six-Year Street Plan as presented by staff. Seconded by Commissioner Carole Shook. Motion passes unanimously, 6-0.**
Voted for by name: President Greg Francis, Vice President Ryan Patterson, Jesse Bank, Sandra Neperud, Carole Shook, Time Williams.

Hearing Adjourned at 4:22 PM

Next regularly scheduled Plan Commission Meeting is on Wednesday, June 12, 2024.



BRIEFING PAPER
Spokane Plan Commission
South Logan TOD Implementation
June 12, 2024

The [South Logan TOD Plan](#), adopted by resolution ([RES 2024-0015](#)) on January 29, 2024 by City Council, provides a recommended framework and policies to create the envisioned future for the South Logan subarea. Recommendations relevant to the current South Logan Implementation proposed text amendments are below.

Developed from community engagement and outreach received during the 20-month process to create the [South Logan TOD Plan](#), draft Spokane Municipal Code (SMC) text amendments were made available for review. The drafts have since been modified based on feedback. The proposed code changes include:

Area-Specific Code Proposals	Citywide Code Proposals
Hamilton Form-Based Code	Center and Corridor Code
Planned Action Ordinance	Height and Height Transitions
	RMF/RHD Open Space Requirements

A Text Amendment Tracking Sheet, below, outlines what sections of code are being modified through this proposal and in what way – whether minor clean up, substantial change, or reorganization.

The below draft text amendments are based on Plan Commission feedback during prior Workshops discussing draft text amendments (April 24, May 8, May 22). There were no changes made between the drafts in the May 22 agenda packet and the enclosed drafts, aside from the tentative numbering for the Planned Action Ordinance going from 17C.415 to 17C.420.

Next Steps

A public hearing with the proposed text amendments – each code proposal as its own ordinance but presented together for clarity – is scheduled for **June 26, 2024**. A staff report with analysis, comments, and relevant exhibits will be available a week before the hearing for review. Unless directed otherwise by Plan Commission, the draft text amendments included in this packet will be the same included in the public hearing agenda for approval.

A formal public comment period started May 17 and will go through June 17 at 5:00 PM. However, comments will be accepted up until the hearing and give to Plan Commission for consideration.

More information is available on the project webpage at:

<https://my.spokanecity.org/projects/south-logan-transit-oriented-development-project/>

South Logan TOD Implementation

Proposed Text Amendment Tracker



The text amendment tracking sheet provides a summary of proposed changes in each section of the Spokane Municipal Code. The text amendment tracking sheet does not replace reviewing the draft code text amendments as there may be additional details and/or minor changes that were not captured in this document.

Existing SMC Section	New SMC Section	Description of Change
SMC 17A.20.160 “P” Definitions		
Section 17A.20.160 “P” Definitions		<ul style="list-style-type: none"> ○ Added “PAO Responsible Official” to the definitions ○ Added “Planned Action” to the definitions
SMC 17C.111.205 Development Standards Tables		
Section 17C.111.205 Development Standards Tables Table 17C.111.205-2 Building and Siting Standards		<ul style="list-style-type: none"> ○ Increased standard height in RMF to 55-feet from 40-feet ○ Increased standard height in RHD to 75-feet from 40-feet ○ Reduced open space requirements in RMF and RHD depending on unit size, with the minimum being 48 sq. ft. per unit. Prior to housing code changes passed in January 2024, the minimum open space required was 48 sq. ft. ○ Reduced open space requirements in RHD for sites 20,000 sq. ft. or less, allowing a minimum of 36 sq. ft. ○ Added residential units with a continuous pedestrian route to a public park within 200 feet to have a maximum open space requirement per unit of 48 sq. ft.

SMC 17C.111.230 Height

Section 17C.111.230 Height		<ul style="list-style-type: none">○ Replaced the permitted height of 70-feet to 75-feet, allowing for the increased height envisioned for podium development○ Properties currently zoned -70 will not increase to 75-feet with this amendment; a rezone of the property would be required○ Changed the transition adjacent to R1 and R2 from 1:2 to 2:1, reducing the slope to make the permitted height feasible in the more intense zones○ Increased starting height from 30-feet to 40-feet○ Removed height exception of an extra 15-feet for RMF/RHD zones with a maximum height of 40-feet; unnecessary with base height increase proposed in SMC 17C.111.205
----------------------------	--	--

SMC 17C.111.420 Open Spaces

(section name changed from Outdoor Spaces)

Section 17C.111.410 Outdoor Spaces	Section 17C.111.410 Open Spaces	<ul style="list-style-type: none">○ Rename outdoor spaces to open spaces to more accurately reflect spaces already permitted to meet minimums○ Reorganized open space standards by private and common space, rather than ground floor and upper floor space○ Emphasized that open space must be useable and accessible to residents of the development○ Add enclosed pet areas, children’s play areas, and community gardens as permitted common open space amenities○ Removed unnecessary and non-descriptive photographs found in the code
---------------------------------------	------------------------------------	--

SMC 17C.120.220 Height

Section 17C.120.220 Height		<ul style="list-style-type: none"> ○ Replaced the permitted height of 70-feet to 75-feet, allowing for the increased height envisioned for podium development ○ Properties currently zoned -70 will not increase to 75-feet with this amendment; a rezone of the property would be required ○ Changed the transition adjacent to R1 and R2 from 1:2 to 2:1, reducing the slope to make the permitted height feasible in the more intense zones ○ Increased starting height from 30 ft to 40ft
SMC 17C.122 Center and Corridor Zones		
Section 17C.122.070 Center and Corridor Zone Allowed Uses		<ul style="list-style-type: none"> ○ Amended to not allow drive-through businesses in CC1 ○ Drive-through businesses still allowed in CC2 and CC3 except for along designated pedestrian streets ○ Removed unnecessary footnote language
Section 17C.122.080 Floor Area Ratios (FAR)		<ul style="list-style-type: none"> ○ REPEALED ○ Floor Area Ratio (FAR) standards relocated to 17C.122.230
Section 17C.122.090 Public Amenities Allowing Bonus FAR	Section 17C.120.090 Public Amenities Allowing Bonus Height	<ul style="list-style-type: none"> ○ Modified to allow bonus height instead of FAR ○ Allows for 15 feet of additional height if all parking is within an entirely below-grade structure, behind the building, or in an above-ground parking garage; or if at least 20% of the residential units are Affordable; or if public art of 1% of development costs is provided ○ Removed other bonus incentives for public spaces and public art
Section 17C.122.100 Maximum Building Height		<ul style="list-style-type: none"> ○ REPEALED ○ Height standards relocated to 17C.122.210
Section 17C.122.110 Setbacks and Required Sidewalk Width		<ul style="list-style-type: none"> ○ REPEALED ○ Setbacks and sidewalk widths relocated to 17C.122.240 and 17C.122.250

	Section 17C.122.200 Development Standards Table	<ul style="list-style-type: none"> ○ NEW SECTION ○ Consolidates development standards tables ○ Increases heights in NC, DC, and EC from 40ft/55ft/150ft to 55ft/75ft/150ft ○ Removes maximum FAR standards ○ Includes minimum FAR standards in District Centers and Employment Centers
	Section 17C.122.210 Height	<ul style="list-style-type: none"> ○ NEW SECTION ○ Height standards relocated from 17C.122.210 ○ Clarifies how height is measured for code consistency
	Section 17C.122.220 Height Transition	<ul style="list-style-type: none"> ○ NEW SECTION ○ Height Transition standards relocated from 17C.122.100 ○ Changed the transition adjacent to R1 and R2 from 1:2 to 2:1, reducing the slope to make the permitted height feasible in the more intense zones ○ Increased starting height from 30 ft to 40ft
	Section 17C.122.230 Floor Area Ratio	<ul style="list-style-type: none"> ○ NEW SECTION ○ Floor Area Ratio (FAR) standards relocated from 17C.122.070 ○ Explains how FAR is measured.
	Section 17C.122.240 Setbacks	<ul style="list-style-type: none"> ○ NEW SECTION ○ Setback standards relocated from 17C.122.110
	Section 17C.122.250 Sidewalks	<ul style="list-style-type: none"> ○ NEW SECTION ○ Sidewalk standards relocated from 17C.122.110
SMC 17C.122T Center and Corridor Zone Development Tables		
Chapter 17C.122T Center and Corridor Zone Development Tables		<ul style="list-style-type: none"> ○ REPEALED ○ Development tables consolidated and relocated to 17C.122.200
SMC 17C.123 Form Based Code Zones		
Section 17C.123.010 Purpose		<ul style="list-style-type: none"> ○ Minor language updates to reflect the Transit-Oriented Development (TOD) emphasis of the South Logan area

Section 17C.123.020 Code Organization	17C.123.020 Context Area and Shopfront Designations	<ul style="list-style-type: none"> ○ Reorganization of regulations found in 17C.123.030 ○ Consolidation of the four Context Areas in the Hamilton Form-Based Code to one Context Area ○ Removal of Street Types for less variable development patterns; replaced with Shopfront designations for high interest street corners
Section 17C.123.030 Regulating & Street Section Plans	17C.123.030 Building Form	<ul style="list-style-type: none"> ○ Reorganization of regulations found in 17C.123.040 ○ Created Table 17C.123.030-1 to better illustrate development regulations outside of graphics ○ Implemented maximum setback in place of build-to lines for code consistency ○ Established exception to maximum setback for public plazas
Section 17C.123.040 Land Use, Height, Placement and Parking	Section 17C.123.040 Permitted Uses	<ul style="list-style-type: none"> ○ NEW SECTION ○ Changed from a list of prohibited uses to a table of permitted uses to reflect standard organization of code and assist in the implementation and transparency of the Hamilton Form-Based Code
Section 17C.123.050 Streetscape Requirements	Section 17C.123.050 Parking and Pedestrian Connectivity	<ul style="list-style-type: none"> ○ Reorganization of regulations found in 17C.123.040
Section 17C.123.060 Architectural Requirements	Section 17C.123.060 Streetscape Requirements	<ul style="list-style-type: none"> ○ Reorganization of regulations found in 17C.123.050 ○ Consolidated regulations to one Context Area and the Shopfront Designation
Section 17C.123.070 Additional Requirements	Section 17C.123.070 Design Standards	<ul style="list-style-type: none"> ○ Reorganization of regulations found in 17C.123.050 ○ Made some regulations more objective by providing specific guidance meeting the intent of the design standard ○ Incorporated guidelines consistent with the South Logan TOD Subarea Plan
Section 17C.123.080 Building Type Catalogs	17C.123.080 Additional Requirements	<ul style="list-style-type: none"> ○ Removed the visual character catalogs as they did not fully encapsulate the permitted designs

		<p>within the Hamilton Form-Based Code and did not include enforceable regulations</p> <ul style="list-style-type: none"> ○ Reorganization of regulations found in 17C.123.070 ○ Removed allowance of barbed wire within the Hamilton Form-Based Code ○ Permitted accessory outdoor sales so long as the Clear Pedestrian Zone and Buffer Zones are maintained
SMC 17C.230 Parking and Loading		
Section 17C.230.120 Maximum Required Parking Spaces		<ul style="list-style-type: none"> ○ Modified CC parking standards, removing minimum parking requirements but keeping maximum parking standards
Section 17C.230.130 Parking Exceptions		<ul style="list-style-type: none"> ○ Text changes aligning with the modified parking table in 17C.230.120 ○ Remove minimum parking in Center and Corridor, Downtown, and Form Based Code zones ○ Changes to make clear when and where parking requirements apply to residential units and Accessory Dwelling Units for improved code useability
SMC 17C.300 Accessory Dwelling Units		
Section 17C.300.130 Development Standards		<ul style="list-style-type: none"> ○ Text changes to align with 17C.230.130 Parking Exceptions ○ Proposed change made for code consistency
SMC 17C.420 South Logan Planned Action Ordinance		
<i>(please note, the chapter number may change before adoption)</i>		
	Section 17C.420.010 Purpose	<ul style="list-style-type: none"> ○ NEW SECTION ○ Identifies the purpose of the South Logan TOD Planned Action Ordinance
	Section 17C.420.015 Procedures and Criteria for Evaluating and Determining Projects as Planned Action	<ul style="list-style-type: none"> ○ NEW SECTION ○ Identifies the Planned Action Area ○ Identifies the South Logan TOD Final EIS as the regulating environmental analysis for the Planned Action Ordinance

		<ul style="list-style-type: none"> ○ Identifies thresholds and criteria to qualify for the Planned Action Ordinance ○ Reinforces the requirement of an Inadvertent Discovery Plan and the process for Historic properties ○ Exempts projects subject to the Shoreline Master Program from qualifying ○ Exempts drive thru facilities from qualifying
	Section 17C.420.020 Planned Action Permit Process and Application	<ul style="list-style-type: none"> ○ NEW SECTION ○ Identifies the permit and application process for the Planned Action Ordinance
	Section 17C.420.025 Monitoring and Review	<ul style="list-style-type: none"> ○ NEW SECTION ○ Establishes a mandate for the City to monitor the progress of development in the Planned Action area and to review the state of the Planned Action Ordinance no later than 5 years from the effective date

17C.420* SOUTH LOGAN TOD PLANNED ACTION ORDINANCE

The proposed South Logan TOD Planned Action Ordinance is an area-specific Spokane Municipal Code Text Amendment that will apply to new development covered by the [South Logan Final Environmental Impact Statement \(FEIS\)](#). Projects that meet the threshold criteria found within the Planned Action Ordinance and comply with any required mitigation as identified in the FEIS are exempt from additional State Environmental Policy Act (SEPA) application and review.

The Planned Action Ordinance is a new code chapter, with no pre-existing language. The proposal also includes the addition of two definitions, in Section 2. Underlined text represents the proposed additions. Text without an underline in Section 2 is existing and not proposed to be modified.

Section 1. That there is adopted Chapter 17C.420 SMC to read as follows:

Chapter 17C.420 South Logan TOD Planned Action 17C.420.010 Purpose

The purposes of this chapter are to:

- A. Designate the South Logan TOD Subarea shown in Figure 17C.420.015-A of this Chapter as a Planned Action Area for purposes of environmental review and permitting of designated Planned Action projects pursuant to RCW.43.21C.440;
- B. Combine environmental analysis, land use plans, development regulations, and City codes and ordinances together with the mitigation measures in the South Logan TOD Final Environmental Impact Statement (FEIS) to mitigate environmental impacts and process Planned Action development applications in the Planned Action Area;
- C. Confirm that the South Logan TOD FEIS meets the requirements of a Planned Action FEIS pursuant to SEPA;
- D. Establish criteria and procedures for the designation of certain projects within the Planned Action Area as Planned Action projects consistent with RCW 43.21C.440;
- E. Provide clear definition as to what constitutes a Planned Action project within the Planned Action Area, identify the criteria for Planned Action project approval, and determine how development project applications that qualify as Planned Action projects will be processed by the City;
- F. Streamline and expediate the land use permit review process by relying on the South Logan TOD FEIS; and

* Please note, the chapter number may change before adoption

- G. Apply the mitigation framework contained in this Ordinance for the processing of Planned Action project applications and incorporate the applicable mitigation measures into the underlying project permit conditions in order to address the impacts of future development contemplated by this Ordinance.

17C.420.015 Procedures and Criteria for Evaluating and Determining Projects as Planned Actions

To qualify for a Planned Action designation, a project application shall comply with the following procedures and criteria for evaluation.

- A. Planned Action Area.

The Planned Action designation shall apply to the approximately 342-acre South Logan TOD area, which is generally bounded by E Augusta Avenue and E Indiana Avenue on the north, N Perry Street and the Spokane River on the east, N Lidgerwood Street on the west, and the Spokane River on the south, and that is specifically shown in Figure 17C.420.015-A, “Planned Action Area.”

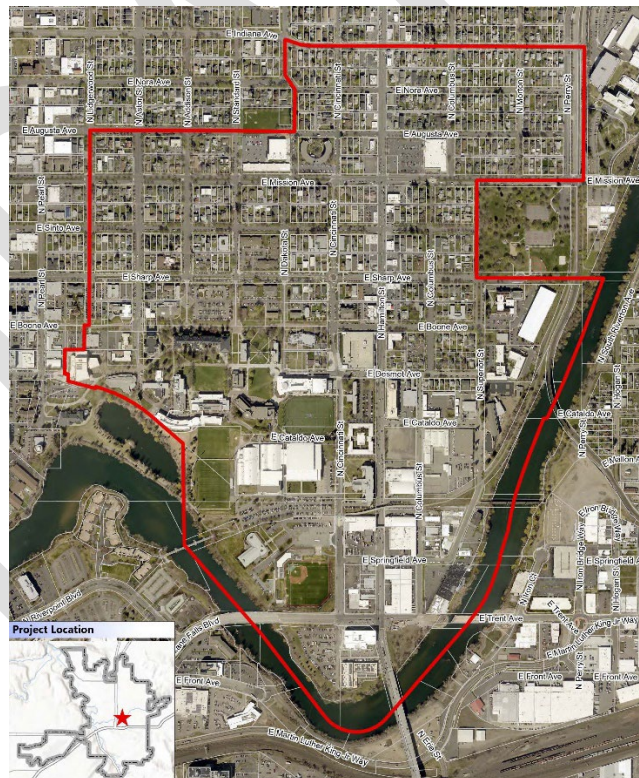

Figure 17C.420.015-A: Map of Planned Action Area

- B. Environmental Document.

* Please note, the chapter number may change before adoption

A Planned Action determination for a site-specific implementing project application shall be based on the environmental analysis contained in the South Logan TOD Final EIS adopted by the City on January 29, 2024 (RES 2024-0015), which adequately identified and addressed environmental impacts of the Planned Action. The mitigation measures contained in the FEIS, [Exhibit A](#), are based upon the findings of the South Logan TOD EIS and shall, along with adopted City regulations, provide the framework that the City will use to review and to impose appropriate conditions on qualifying Planned Action projects.

C. Planned Action Projects Designation.

Land uses and activities described in the South Logan TOD FEIS, subject to the thresholds described in subsection D of this section and the mitigation measures contained in [Exhibit A](#), are designated Planned Actions or Planned Action projects pursuant to [RCW 43.21C.440](#) and [WAC 197-11-172](#) (“Planned Action Project”). A development application for a site-specific Planned Action project located within the South Logan TOD Planned Action area that meets the criteria set forth in subsection D of this section and applicable laws, codes, development regulations and standards, may be designated a Planned Action Project pursuant to the process in SMC Section 17C.420.020.

D. Planned Action Qualifications.

The following thresholds shall be used to determine if a site-specific development proposed within the South Logan TOD Planned Action area qualifies as a Planned Action Project and has had its environmental impacts evaluated in the South Logan TOD FEIS:

1. Qualifying Uses.

a. Planned Action Categories.

The primary land uses and levels of development as envisioned in the South Logan TOD Preferred Alternative and as reviewed in the South Logan TOD FEIS, along with conditional and accessory uses permitted in the associated zones, are considered Planned Actions. The primary uses include residential, commercial, and mixed-use development.

2. Planned Action Project Primary Uses.

* Please note, the chapter number may change before adoption

A Planned Action Project may be a single Planned Action use, or a combination of Planned Action uses within a mixed-use development. A land use can qualify as a Planned Action Project when:

- a. It is within the Planned Action Area; and
 - b. It complies with the land use plan map designation of the property identified in the South Logan TOD Preferred Alternative or has a lower intensity designation; and
 - c. Is within one or more of the primary uses described in Subsection D.1 above; or
 - d. It is a permitted accessory use or appurtenant to a permitted use.
3. Public Services.

The following public services, infrastructure, and utilities may also qualify as Planned Action Projects: streets and non-motorized improvements, utilities, parks, trails, civic, cultural, governmental, and similar facilities developed consistent with the South Logan TOD FEIS mitigation measures, City design standards, critical area regulations, and the Spokane Municipal Code.

4. Development Thresholds.
- a. The following amount of increase in housing is contemplated by the Planned Action:

Increase in New Housing Units ¹	2,954
Associated Population Increase	6,735

¹ Includes equivalent housing added in college dormitories.

- b. If future development proposals in the South Logan TOD Planned Action area exceed the development thresholds specified in this chapter, further environmental review may be required pursuant to [WAC 197-11-172](#). Further, if the proposed development would alter the assumptions and analysis in the South Logan TOD FEIS, further environmental review may be required.
5. Building Heights.

* Please note, the chapter number may change before adoption

Building heights shall not exceed the maximums identified and reviewed in the South Logan TOD Final FEIS and South Logan TOD Plan.

6. Transportation.

- a. The Preferred Alternative is anticipated to generate approximately 928 new PM peak-hour vehicle trips. This equates to approximately 9 percent higher traffic volumes in the area compared to the 2045 No Action alternative.

- b. Trip Threshold.

Uses or activities that would exceed the forecasted trips shown above would not qualify as Planned Actions and would require additional transportation review.

- c. City Engineer Discretion.

The City Engineer or their designee shall have discretion to determine incremental and total trip generation, consistent with the Institute of Traffic Engineers (ITE) Trip Generation Manual (latest edition) or an alternative manual accepted by the City Engineer, for each project permit application proposed under this planned action.

- d. Transportation Improvements and Mitigation.

- i. On-Site and Off-Site Improvements.

The Planned Action may require on-site and off-site transportation improvements to mitigate significant adverse impacts as development occurs. These transportation improvements are identified in the South Logan TOD FEIS and South Logan TOD Plan. The City shall have the discretion to adjust the allocation of responsibility for required improvements between individual Planned Action projects based on their identified impacts.

- ii. Hamilton and Trent.

The intersection of N Hamilton Street/E Trent Avenue is forecasted to operate at LOS E during the 2045 No Action and LOS F with full development of Planned Action projects. Any

development must implement measures to restore the LOS and delay to its pre-development level of LOS E.

7. Elements of the Environment and Degree of Impacts.

A proposed project that would result in a significant change in the type or degree of impacts to any of the elements of the environment analyzed in the South Logan TOD FEIS, EIS addendum, and/or supplemental EIS, would not qualify as a Planned Action.

8. Changed Conditions.

Should environmental conditions change significantly from those analyzed in the FEIS, the City's PAO Responsible Official may determine that the Planned Action designation is no longer applicable until a supplemental environmental review is conducted.

9. Additional Mitigation Fees.

The City may adopt and apply such other fees as may be deemed necessary and appropriate to mitigate impacts to other capital facilities in the Planned Action area and to accommodate planned growth. Such fees, if adopted, shall be in addition to the fee required in subsection (D)(4)(d) of this section, and shall apply only to required improvements that are not addressed in this subsection.

10. Inadvertent Discovery Plan.

An Inadvertent Discovery Plan (IDP) should be implemented into the scope of work for all projects within the Planned Action area. The IDP should outline procedures to perform in the event of a discovery of archaeological materials or human remains. The IDP should always be kept at the project site during all project activities. If any artifacts or human remains are found upon excavation, the Tribal Historic Preservation Office (THPO), Washington State Department of Archaeology and Historic Preservation (DAHP), and Spokane Historic Preservation Office shall be immediately notified and the work in the immediate area cease.

11. Historic Preservation Design Review.

Properties individually placed on the Spokane Register of Historic Places or located within one of Spokane's designated historic districts must meet all requirements of the Spokane Historic Preservation Office, including

* Please note, the chapter number may change before adoption

obtaining a Certificate of Appropriateness from the Spokane Historic Landmarks Commission or the Historic Preservation Officer for proposed changes or additions to historic structures when necessary.

12. Demolitions.

Buildings fifty years of age or greater at time of demolition permit submittal shall provide a Level 2 Site Inventory Form unless determined by the Historic Preservation Officer and Planning Director to not be of historic significance.

13. Shoreline Master Program.

Areas within the Planned Action area subject to the Shoreline Master Program are not exempt from permitting or SEPA review through the FEIS and must comply with Chapter 17E.060 SMC Shoreline Regulations.

14. Uses.

Drive-thru facilities, including accessory drive-thru features, are not exempt from SEPA review and do not qualify as Planned Action Projects.

E. Planned Action Review Criteria.

1. The City's PAO Responsible Official may designate as "Planned Actions," pursuant to RCW 43.21C.030, applications that meet all of the following conditions:

- a. The proposal is located within the Planned Action Area identified in SMC 17C.420.015, or is an off-site improvement directly related to the proposed development within the Planned Action Area; and
- b. The proposed uses and activities are consistent with those described in the FEIS and subsection D of this section; and
- c. The proposal is within the Planned Action thresholds and other criteria of subsection D of this section; and
- d. The proposal is consistent with the City of Spokane Comprehensive Plan and the South Logan TOD Plan; and
- e. The proposal's significant adverse environmental impacts have been identified in the South Logan TOD FEIS; and

* Please note, the chapter number may change before adoption

- f. The proposal's significant impacts have been mitigated by the application of measures identified in Exhibit A, and other applicable City regulations, together with any modifications or variances or special permits that may be required; and
 - g. The proposal complies with all applicable local, state, and/or federal laws and regulations, and the PAO Responsible Official determines that these constitute adequate mitigation; and
 - h. Adequate infrastructure improvements are in place, or will be in place at completion of the project, to support the development of the project; and
 - i. The proposal is not an essential public facility as defined by RCW 36.70A.200, unless the essential public facility is part of or accessory to a residential, office, school, commercial, recreational, or service that is designated as a Planned Action.
2. The City shall base its decision on designation as a Planned Action project on review of a Planned Action checklist, or an alternative form developed consistent with applicable provisions of Chapter 43.21C RCW, and review of the application and supporting documentation.
 3. A proposal that meets the criteria of this section shall be considered to qualify and be designated as a Planned Action, consistent with the requirements of RCW 43.21C.440, WAC 197-11-164 et seq., and this chapter.
- F. Effect of Planned Action.
1. Designation as a Planned Action project means that a qualifying proposal has been reviewed in accordance with this chapter and found to be consistent with its development parameters and thresholds, and with the environmental analysis contained in the South Logan TOD FEIS.
 2. Upon determination by the City's PAO Responsible Official that the proposal meets the criteria of section (D) of this section and qualifies as a Planned Action, the proposal shall not require a SEPA threshold determination, preparation of an EIS, or be subject to further review pursuant to SEPA.

17C.420.020 Planned Action Permit Process and Application

Applications for Planned Actions shall be reviewed pursuant to the following process:

* Please note, the chapter number may change before adoption

- A. Applications shall be made on forms provided by the City, including an approved Planned Action Checklist, and shall meet the applicable requirements of the Spokane Municipal Code.
- B. After the City receives a complete application, the PAO Responsible Official shall determine whether the project qualifies as a Planned Action Project under this chapter.
- C. Once a project is determined to qualify as a Planned Action Project under this chapter, the City shall:
 - 1. Notify the applicant and the project shall proceed in accordance with the applicable permit review procedures; and
 - 2. Notify Spokane Tribe of Indians, Spokane Historic Preservation Office, internal City Departments, utility providers, and other partner agencies as deemed appropriate by the assigned project manager of the pending development under South Logan TOD FEIS. The notice required by this section may be combined with the public notice required or provided with the underlying permit and may take the form of the environmental checklist or other project review form. Notice provided shall not be less than 14 days.
- D. If a project does not qualify as a Planned Action under this chapter, the City shall notify the applicant. The notice shall describe the elements of the application that result in failure to qualify as a Planned Action.
 - 1. Projects that fail to qualify as Planned Actions may incorporate or otherwise use relevant elements of the South Logan TOD Plan and FEIS to meet SEPA requirements. The City may limit the scope of the SEPA review for the non-qualifying project to those issues and environmental impacts not previously addressed in the Planned Action.

17C.420.025 Monitoring and Review

- A. The City shall monitor the progress of development in the designated Planned Action area to ensure that it is consistent with the assumptions of this chapter and the South Logan TOD FEIS regarding the type and amount of development and associated impacts, and with the mitigation measures and improvements planned for the Planned Action Area.
- B. This Planned Action Ordinance shall be reviewed no later than five (5) years from its effective date to determine the continuing relevance of its assumptions and findings with respect to environmental conditions in the Planned Action area, the

* Please note, the chapter number may change before adoption

impacts of development, and required mitigation measures. Based upon this review, the City may propose amendments to this ordinance and/or may supplement or revise the South Logan TOD FEIS.

Section 2. That SMC Section 17A.20.160 is amended to read as follows:

17A.20.160 “P” Definitions

A. Painted Wall Highlights.

See SMC 17C.240.015.

B. Painted Wall Sign.

See SMC 17C.240.015.

C. PAO Responsible Official.

The Planning Director, serving in the capacity of administrative official of the lead agency.

D. Parcel.

See “Lot” (SMC 17A.020.120).

E. Parkway.

A thoroughfare designated as a collector or arterial, with a median reflecting the park-like character implied in the name - SMC 17D.050A.040.U.

F. Party of Record.

Any person who has appeared at a hearing of the hearing examiner by presenting testimony or making written comment.

G. Paved Area.

1. An uncovered, hard-surfaced area or an area covered with a perforated hard surface (such as “Grasscrete”) that is able to withstand vehicular traffic or other heavy-impact uses.
2. Graveled areas are not paved areas.

H. Pedestrian Buffer Strips (PBS).

* Please note, the chapter number may change before adoption

A hard-surfaced or planted area(s) between travel or parking lanes and sidewalks, also called planting strips. PBS improves safety by separating vehicles and pedestrians and provide space for drainage, street trees and snow storage.

I. Pedestrian Path.

A continuous, unobstructed, reasonably direct route between an on-site parking lot and a Primary Building Entry designed and suitable for pedestrian use. Minimum requirements for Pedestrian Paths are listed in [Section 17C.123.040](#) of the FBC.

J. Pedestrian-Scaled Fixtures (lighting).

Pole-mounted light fixtures placed and designed to illuminate foot-traffic areas including exterior lots, pathways or sidewalks. For purposes of the HFBC, Pedestrian-Scaled Fixtures are defined by height as measured from ground to bottom of shade or bulb.

K. Pedestrian-Scaled Signs.

[See SMC 17C.240.015.](#)

L. Pedestrian Street.

1. A street designated on the official zoning map as a pedestrian street where development standards are required to promote a pedestrian friendly street. Pedestrian streets offer a pleasant and safe walking environment. Design features include minimal interruptions of the sidewalk by driveways, publicly usable site furnishing such as benches, tables, and bike racks, and visually interesting buildings close to the sidewalk.

M. Performance Guarantee.

A “financial guarantee” providing for and securing to the City the actual construction and installation of the required improvements.

N. Performance/Warranty Retainer.

A “financial guarantee” both providing for and securing to the City the actual construction and installation of such improvements, and securing to the City the successful operation of the improvements for two years after the City’s final inspection and acceptance of the improvements.

O. Permanent Erosion and Sediment Control Measures.

A combination of plants, mulch, sod, matting, erosion control blankets, and permanent structures that will provide long-term soil stabilization.

* Please note, the chapter number may change before adoption

P. Permanent Sign.

[See SMC 17C.240.015.](#)

Q. Permanent Stabilization.

See Permanent Erosion and Sediment Control Measures.

R. Permeable Sediment.

Sediment permitting the flow of water.

S. Person.

Any natural person, whether acting individually or in a representative capacity, partnership, joint venture, corporation, or other legal entity.

T. Pier.

Any platform structure, fill, or anchored device in or floating upon water bodies to provide moorage for watercraft engaged in commerce, including, but not limited to, wharves, mono-buoys, quays, ferry terminals, and fish weighing station.

U. Planned Action.

A Planned Action means one or more types of project action that:

1. Are designated Planned Actions by an ordinance or resolution; and
2. In conjunction with, or to implement, an adopted comprehensive plan or subarea plan that have had the significant impacts adequately addressed in an Environmental Impact Statement under the requirements of WAC 197-11-64; and
3. Is exempt from additional SEPA review for all elements covered under the Environmental Impact Statement of the adopted comprehensive plan or subarea plan.
4. Is defined in WAC 197-11-164.

V. Planned Capacity.

For all capital facilities, except transportation, capacity for a concurrency facility that does not exist, but for which the necessary facility construction, expansion, or modification project is contained in the current adopted City of Spokane

* Please note, the chapter number may change before adoption

comprehensive plan, capital improvement program and scheduled to be completed within six years. (RCW 36.70A.020).

W. Planned Capacity for Transportation Facilities.

Capacity for transportation facilities, including roads and transit, that does not exist, but where transportation improvements or strategies to accommodate the impacts of development are made concurrent with the development.

1. These strategies may include:
 - a. increased public transportation service,
 - b. ride sharing programs,
 - c. demand management, and
 - d. other transportation systems management strategies.
2. For transportation facilities, “concurrent with the development” shall mean that improvements or strategies are in place at the time of development, or that a financial commitment is in place to complete the improvements or strategies within six years (RCW 36.70A.070(6)(b)).

X. Planned Unit Development (PUD).

1. A planned unit development is a project permit for an overlay zone, approved by the hearing examiner, which does not fully comply with all of the development standards of the base zone in which it is located, but is approved based on superior or innovative design
2. The City may permit a variety of types, design, and arrangement of structures and enable the coordination of project characteristics with features of a particular site in a manner consistent with the public health, safety, and welfare.

Y. Plans.

Planning documents, which are developed by the various departments of the City, pertaining to the orderly development of public facilities.

Z. Planting Zone.

Area for street trees, ground cover or other plantings; typically included herein as a portion of overall sidewalk width reserved for locating permanent trees and tree grates.

* Please note, the chapter number may change before adoption

AA. Plat – Final.

A map or representation of a subdivision, showing thereon the division of a tract or parcel of land into lots, blocks, streets, alleys, or other divisions and dedications and containing all elements and requirements set forth in this chapter and chapter 58.17 RCW.

BB. Plat – Preliminary.

1. A neat and approximate drawing of a proposed subdivision showing the general layout of streets, alleys, lots, blocks, and other elements of a subdivision required by this chapter and chapter 58.17 RCW.
2. The preliminary plat shall be the basis for the approval or disapproval of the general layout of a subdivision.

CC. Plaza.

Areas generally open to the public on a controlled basis and used for passive recreational activities and relaxation.

Plazas are paved areas typically provided with amenities, such as seating, drinking, and ornamental fountains, art, trees, and landscaping, for use by pedestrians.

DD. Plinth.

The base or platform upon which a building wall or column appears to rest, helping establish pedestrian-scaled elements and aesthetically tying the building to the ground.

EE. Pollutant.

Any substance which is prohibited or limited by applicable laws or regulations, which is released or discharged in conjunction with development. Any substance that causes or contributes to violation of air, land, or water quality standards, released or discharged.

FF. Pollution.

Contamination, or other alteration of the physical, chemical, or biological properties of air, land, water or wetlands, or such discharge of any liquid, gaseous, solid, radioactive, or other substance into air, land, water, or wetlands as will or is likely to cause a nuisance or render such air, land, water, or wetlands harmful, detrimental, or injurious to the public health, safety, or welfare, or to domestic, commercial, industrial, agricultural, recreational, or other legitimate beneficial uses, or to livestock, wildlife, fish, native vegetation, or other aquatic life.

* Please note, the chapter number may change before adoption

GG. Potential Geologically Hazardous Areas.

Areas designated on maps maintained in the City's planning and economic development services department. They are classified "potential" because they have not been confirmed by field investigation nor do they necessarily include the full extent of all geologically hazardous areas within the City. The maps are intended to alert property owners, purchasers, developers, etc., to the possible existence of significant geological hazards, which may warrant further geotechnical study.

HH. Practicable Alternative.

An alternative that is available and capable of being carried out after taking into consideration cost, existing technology, and logistics in light of overall project purposes and having less impact to critical areas. It may involve using an alternative site in the general region that is available to the applicant and may feasibly be used to accomplish the project.

II. Predevelopment Meetings.

Meetings between City or agency staff and an applicant or their representatives prior to formal submission of a detailed application. They are intended to provide an overview of the regulatory requirements, application process, and procedural submission requirements.

JJ. Principal Buildings.

Where multiple buildings occupy a single lot, those buildings that are associated with the prevailing use of that site.

KK. Primary Building Entry.

Access or entrance of first rank, importance or value, visually associated with the prevailing ground-floor use of a building.

LL. Primary Building Walls.

Any exterior building wall that faces a street and contains a public entrance to the occupant's premises or tenant space. If an individual tenant space does not have a street facing wall, or does not have a street facing wall containing a public entrance, then the primary building wall for that individual tenant space is any wall containing a public entrance that faces a parking area on the site. (See Figure 1, [SMC 17C.240.130](#), Primary Building Walls)

MM. Primary Container.

* Please note, the chapter number may change before adoption

The container that is in direct contact with the material of concern during the course of normal transport, use, or storage.

NN. Primary Drainage Basin.

The basin of the stream or tributary within which a project is proposed, not including basins of major tributaries. For the purpose of this regulation the primary drainage basin of:

1. Latah Creek is not a part of the primary drainage basin of the Spokane River,
2. Marshall Creek is not a part of the primary drainage basin of Latah Creek.

OO. Primary Structure.

1. A structure or combination of structures of chief importance or function on a site. In general, the primary use of the site is carried out in a primary structure.
2. The difference between a primary and accessory structure is determined by comparing the size, placement, similarity of design, use of common building materials, and the orientation of the structures on a site.

PP. Primary Use.

1. An activity or combination of activities of chief importance on the site. One of the main purposes for which the land or structures are intended, designed or ordinarily used.
2. A site may have more than one primary use.

QQ. Principal Arterials.

A street serving major activity centers, providing a high degree of mobility and serving the longest trip demands within the urban area.

RR. Priority Habitats.

Habitat areas determined by WDFW to have unique or significant value to many species and that meet one or more of the following criteria:

1. High wildlife density.
2. High species diversity.

* Please note, the chapter number may change before adoption

3. Important wildlife breeding habitat.
4. Important wildlife seasonal ranges.
5. Important movement corridors.
6. Limited availability.
7. High vulnerability to habitat alteration.

SS. Priority Species.

A wildlife species requiring protective measures for their perpetuation due to their population status, their sensitivity to habitat alteration, and/or their recreational importance.

TT. Private Street.

Roadway which is not controlled or maintained by a public authority, and which serve two or more properties.

UU. Project Permit or Project Permit Application.

Any land use or environmental permit or license required for a project action, including, but not limited to, building permits, short plats, subdivisions, binding site plans, planned unit developments, conditional uses, shoreline substantial development permits, site plan review, permits, or approvals required by the critical area ordinance, and site specific rezones authorized by a comprehensive plan or subarea plan, but excluding the adoption or amendment of a comprehensive plan, subarea plan, or development regulations, except as otherwise specifically identified under RCW 36.70B.140.

VV. Projecting Sign.

[See SMC 17C.240.015.](#)

WW. Protected Species.

A general classification of animals by WDFW that includes all those species not classified as listed, game, fur-bearing, or non-protected. This also includes all birds not classified as game or non-protected.

XX. Proximity.

That two or more properties are either adjacent or separated by a street or alley.

* Please note, the chapter number may change before adoption

YY. Public Access.

The public's right to get to and use the City's public waters, the water/land interface and associated shoreline area. It includes physical access that is either lateral (areas paralleling the shore) or perpendicular (an easement or public corridor to the shore), and/or visual access facilitated by means such as scenic streets and overlooks, viewing towers, and other public sites or facilities.

ZZ. Public Facilities.

Any City-owned, operated, or contracted public facility or service in whole, or in part, whether existing or planned, including, but not limited to:

1. parks,
2. recreation facilities,
3. playgrounds,
4. streets,
5. transportation facilities,
6. open spaces,
7. fire facilities,
8. storm water drainage ponds, and
9. all such appurtenances and improvements.

AAA. Public Property.

Any City-owned real property, air space, or other interest in real estate, including streets, alleys, or other public rights-of-way, owned by or controlled by this municipality or any other governmental unit.

BBB. Public Way.

1. A dedicated "public way" is a tract of land:
 - a. conveyed or reserved by deed,
 - b. dedicated by plat, or

* Please note, the chapter number may change before adoption

- c. acquired by decree of court,
 - d. which has been accepted and dedicated by action of the city council to the public right-of-way and for secondary use as an easement for public utilities.
2. An “alley” is a public way, usually not exceeding sixteen feet in width, designed or intended to provide secondary access to abutting properties.

DRAFT

17C.123 FORM BASED CODE ZONES

The proposed amendments to the Hamilton Form-Based Code (FBC) is an area-specific Spokane Municipal Code Text Amendment that implement recommendations from the [South Logan TOD Plan](#). These changes are intended to make strategic adjustments to the existing FBC to enhance transit-oriented development opportunities, while retaining standards that ensure future development is pedestrian-oriented and contributes to the area. The proposal includes consolidating the context areas and street types within the area to improve useability and predictability, identifying Shopfront designations for targeted intensity, integrating visual regulations into standard tables and code format, and general reorganization. The reorganization of the code has resulted in large sections of the Hamilton FBC to be “repealed” and relocated, as noted in the text amendment tracking sheet.

*Text with ~~((**strikethrough**))~~ is proposed to be repealed/modified with underlined text representing proposed text. Text without a strikethrough or underline is existing and not proposed to be modified.*

Section 1. That SMC Section 17C.123.010 is amended to read as follows:

Section 17C.123.010 Purpose

~~((The form-based zoning categories implement the centers and corridors goals and policies and land use map designations of the comprehensive plan. This form-based code)) The Hamilton Form-Based Code (FBC) is designed to foster an economically vibrant, walkable, mixed-use environment along the Hamilton Street corridor within the boundaries of the code. This code regulates land development by setting careful and coherent controls on building form, coupled with performance-based parameters relative to building use and ~~((density))~~ intensity. ~~((This greater emphasis on physical form is intended to produce safe, attractive and enjoyable public spaces, including a healthy mix of uses.))~~ Through emphasis on physical form, the Hamilton FBC promotes connectivity and livability with safe, accessible public spaces, a healthy mix of uses, and access to transit.~~

~~((The FBC is a pilot program and is configured as a plug-in set of regulations, replacing existing zoning and design guidelines within the FBC Limits. This pilot program is consistent with the Logan Identify Plan. All code provisions expressed herein present development requirements unless otherwise indicated, including information preceded by the word “Guidelines.” Additional, specific City of Spokane standards may be required as referenced.))~~

Where not otherwise regulated within this Chapter, development within the Hamilton FBC area shall meet all applicable regulations of the Spokane Municipal Code.

Section 2. That SMC Section 17C.123.020 is amended to read as follows:

17C.123.020 ((~~Code Organization~~)) Context Area and Store Front Designations

~~((Using this code: Criteria for development within the code boundaries is expressed in six sections. Use of the FBC, relating to each of these sections, is described below:~~

~~A. Regulating & Street Section Plans.~~

~~Find the property of interest, noting its location relative to the “Context Areas” established by the Regulating Plan, as well as the location of any “Shopfront Streets” abutting the property. These elements direct many of the allowances provided in the FBC.~~

~~B. Height, Placement & Coverage.~~

~~Using criteria from the Regulating Plan, note the allowed maximum building heights; build-to-lines; minimum building frontages, and impervious surface coverage allowances detailed in this section.~~

~~C. Parking Criteria & Site Access.~~

~~Using criteria from the Regulating Plan and the Street Section Plan, note the various allowances regarding off-street surface parking, lot placement, lot and site lighting.~~

~~D. Streetscape Requirements.~~

~~Using type criteria from the Street Section Plan, note the basic configuration and feature specifications for sidewalks and pedestrian buffer zones within the FBC Limits.~~

~~E. Architectural Requirements.~~

~~Using criteria from the Regulating Plan, note the various façade treatments, screening, detailing and other requirements specific to the appearance and public-realm function of buildings.~~

~~F. Additional Requirements.~~

~~This section identifies additional requirement not covered by the HFBC.~~

~~G. Building Type Catalogs.~~

~~This section provides a visual catalog of desired building characteristics.))~~

The Hamilton Form-Based Code (FBC) area is regulated by a Context Area. Identified intersections are assigned Shopfront designations, which include additional requirements and allowances.

A. Context Area.

Context Area 1 (CA1) is the implementing zone of the Hamilton FBC. Figure 17C.123.010-A illustrates the location of the C1 zoning.



Figure 17C.123.010-A
Context Area Map

B. Shopfront Designations.

Shopfront designations are assigned to key intersections within the Hamilton FBC to allow for increased height and pedestrian-oriented design. Figure 17C.123.010-B illustrates the location of the Shopfront designations.



**Figure 17C.123.010-B
Shopfront Designations**

Section 3. That SMC Section 17C.123.030 is amended to read as follows:

17C.123.030 ((Regulating & Street Section Plans)) Building Form

~~((This section provides and describes the FBC Regulating Plan and Street Section Plan –two map illustrations showing the location and limits of various features and physical characteristics required under this code. The Regulating Plan also indicates placement and extents of “Shopfront Street” areas, triggering specific use, building placement and other requirements.~~

~~A.——Regulating Plan.~~

~~The Regulating Plan for the FBC is included here as Figure 17C.123.030-1, and provides the organizing framework for many of the requirements described herein. The Regulating Plan divides land within the code boundaries into four distinctive context areas and identifies shopfront streets, listed and described as follows:~~

- ~~1.—— CA 1: Context Area 1 provides for and supports the most intense development patterns, generally allowing greater height and building intensities than other context areas. CA-1 is intended to grow as a mixed-use center and focal point for the neighborhood and corridor, supporting significant commercial offerings, service activities, and high-density housing.~~

- ~~2. CA-2: Context Area 2 provides for and supports mid-range development intensities, allowing somewhat lesser height and building intensities than CA-1. CA-2 is intended to grow as a second-tier mixed-use center for the neighborhood and corridor, supporting commercial offerings, service activities, and high-density housing.~~
- ~~3. CA-3: Context Area 3 provides for and supports low to mid-range development intensities, allowing lesser height and building intensities than CA-1 or CA-2. CA-3 is intended to grow as a second-tier mixed-use area for the neighborhood and corridor, providing continuity along Hamilton by linking CA-1 and CA-2, while at the same time acting as a transition zone between the corridor environment and CA-4 and neighborhood areas immediately outside the HFBC Limits.~~
- ~~4. CA-4: Context Area 4 provides for and supports low to mid-range development intensities, allowing lesser height and building intensities than other context areas. CA-4 is intended to grow as a third-tier mixed-use area for the neighborhood and corridor, acting as a transition zone between the corridor environment and lower-density residential development immediately outside the FBC Limits. Though a mix of uses are allowed in CA-4, the area is envisioned as generally residential in scale and character.~~
- ~~5. Shopfront Street: provides for areas where specific uses, building placement, and other requirements apply. The shopfront street is generally applied to areas where business or retail use level with and directly along the public right-of-way is seen as critical.~~

~~B. Street Section Plan.~~

~~The Context Area Zones are complemented by the Street Section Plan which is included here as Figure 17C.123.030-2 and guides public and private development within the FBC Limits. The Street Section Plan defines four section types and describes amenities based upon the intended use, desired qualities, and community objectives. Right-of-ways shall not be vacated as the space is needed to incorporate the elements described in street designations below. Curb to property line and the sidewalk width shall not be reduced in order to allow for future Street Section elements. The four section types are listed and generally described in order of intensity, as follows:~~

- ~~1. Street Type 1 (Hamilton Street): Type 1 provides for and supports a mixed-use corridor environment (CA-1, CA-2, CA-3). Type 1 streets have wide, well-maintained sidewalks and pedestrian amenities to encourage strolling, walking, and shopping. They maintain a Planting Zone and Clear Pedestrian Zone on each side of the street.~~

2. ~~Street Type 2 (Mission Avenue): Type 2 provides for and supports a blend of mixed-use and residential environments (CA-1, CA-4). Type 2 serves existing east/west arterial needs, and includes a median with turn lanes (at Hamilton), a Planting Zone and Clear Pedestrian Zone on each side of the street.~~
3. ~~Street Type 3 (Includes Sinto, Sharp, Boone): Type 3 provides for and supports a mixed-use district environment (CA-2, CA-3, CA-4). Type 3 includes a Planting Zone and Clear Pedestrian Zone on each side of the street.~~
4. ~~Street Type 4 (Includes Augusta and Dakota): Type 4 provides for and supports an environment bridging between mixed-use and residential areas (CA-4). Type 4 includes a Planting Zone and Clear Pedestrian Zone on each side of the street.))~~



~~((Figure 17C.123.030-1 Regulating Plan for the Form Based Code))~~

[NOTE: Delete graphic above]

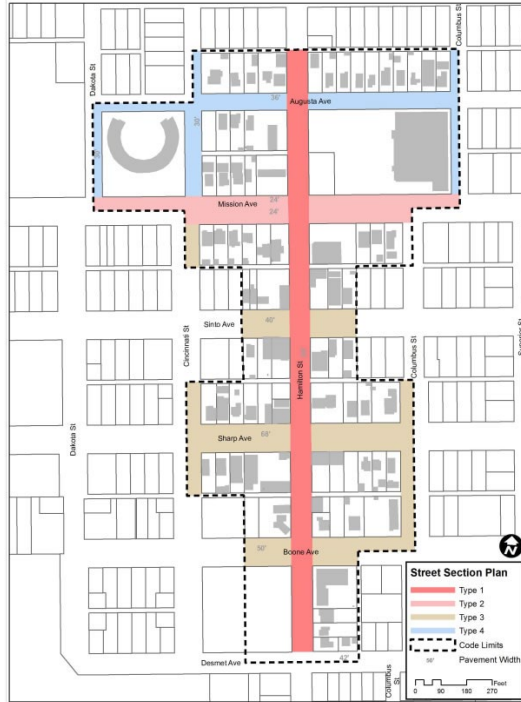

((Figure 17C.123.030-2 Street Section Plan for the Form Based Code))

[NOTE: Delete graphic above]

Within the Hamilton Form-Based Code (FBC), an emphasis is placed on building form and location in order to ensure a vibrant mixed-use environment that supports a range of transportation options, including transit, walking, and rolling.

A. Building Form Standards.

Table 17C.123.030-1 Hamilton FBC Building Form		
	<u>CA1</u>	<u>Shopfront</u>
<u>Maximum Height [1]</u>	<u>75 ft.</u>	<u>150 ft.</u>
<u>Impervious Surface Maximum</u>	<u>100%</u>	<u>100%</u>
<u>Setbacks</u>		
<u>Minimum Front Setback [2]</u>	<u>0 ft.</u>	<u>0 ft.</u>
<u>Maximum Front Setback [2] [3]</u>	<u>15 ft.</u>	<u>0 ft.</u> <u>10 ft. along Hamilton</u>
<u>Minimum Interior Side Lot Line</u>	<u>0 ft.</u>	
<u>Minimum Interior Side Lot Line – adjacent to RMF or RHD</u>	<u>5 ft.</u>	
<u>Minimum Rear</u>	<u>0 ft.</u>	
<u>[1] Development of 70 feet or more shall meet all applicable requirements of SMC 17C.250 Tall Building Standards.</u>		

[2] When the existing sidewalk width is less than 12 feet, structures shall be allowed no closer than 12 feet from the back of the curb.

[3] A public plaza meeting all requirements of SMC 17C.123.030C(1)(2)(i) may extend the maximum setback an additional 10 feet

B. Height.

1. Building height is the vertical distance from the average grade to the highest point of the roof or structure.
2. Height Exceptions.
 - a. Pitched roofs may extend above the height limit, but if the space within the pitched roof is habitable, it shall only be used for residential purposes.
 - b. For flat roofs, open roof structures (pergolas, arbors) and architectural roof structures (turrets, etc.) may extend beyond the height limit by no more than 12'.
 - c. For flat roofs, enclosed roof structures (penthouses) may extend above the height limit by no more than 18' from the roof line if set back at least 20' from all street lot lines.

C. Building Placement.

1. Shopfront Designations.
 - a. Building placement along Shopfront Streets shall prioritize street corner locations, precluding the development of parking, open spaces, or other lot features at street corners.
 - b. Exceptions.
 - i. Public Plaza.

A plaza or courtyard, with a minimum area of four hundred square feet or two percent of the total interior floor space of the development, whichever is greater, may be located between a building and the street corner so long as the plaza:

 - a. is a level space accessible to the public;
 - b. is at least ten feet in width;
 - c. is within thirty inches of the grade of the sidewalk providing access to it;

- d. has no more than sixty percent of the area covered in vegetation; and
- e. includes seating, pedestrian-scale lighting, decorative paving, and other pedestrian furnishings.

Section 4. That SMC Section 17C.123.040 is amended to read as follows:

17C.123.040 ((~~Land Use, Height, Placement and Parking~~)) Permitted Uses

~~((This section provides a broad range of allowable use categories within the Regulating Plan limits, specifying permitted and prohibited uses according to building story reflecting the development patterns expressed in the Regulating Plan. This section also regulates building height, placement, frontage and impervious surface coverage, specifying each within the Context Areas provided in the Regulating Plan and managing the transition between high-intensity mixed-use areas and low-intensity residential areas outside the limits of this form-based code. This section also regulates parking, parking lot location and treatment, and site lighting, consistent with the Regulating Plan. Conformance with these standards is critical to establishing the type of pedestrian and vehicular access patterns needed for the area to thrive as a vibrant, walkable district.~~

~~A. Use Provisions.~~

~~Use regulations are provided in figures 17.123.040-D through 17.123.040-G for all areas within the Regulating Plan. Uses deemed unsuitable for areas within the Regulating Plan area are specifically identified.~~

~~B. Building Height.~~

~~The height of buildings shall be measured from mean grade to top of cornice or roof eave and shall meet the specifications provided in figures 17.123.040-D through 17.123.040G. Building height measurements express regulatory standards.~~

- ~~1. Maximum height limits in CA-1, CA-2, and CA-3 are allowed only within 100' to 114' of the Hamilton right of way line to match the platting pattern along Hamilton. Beyond 100' from Hamilton, proposals shall be designed with respect for the height, scale and character of adjacent zone as described in Figure 17C.123.040-A:))~~

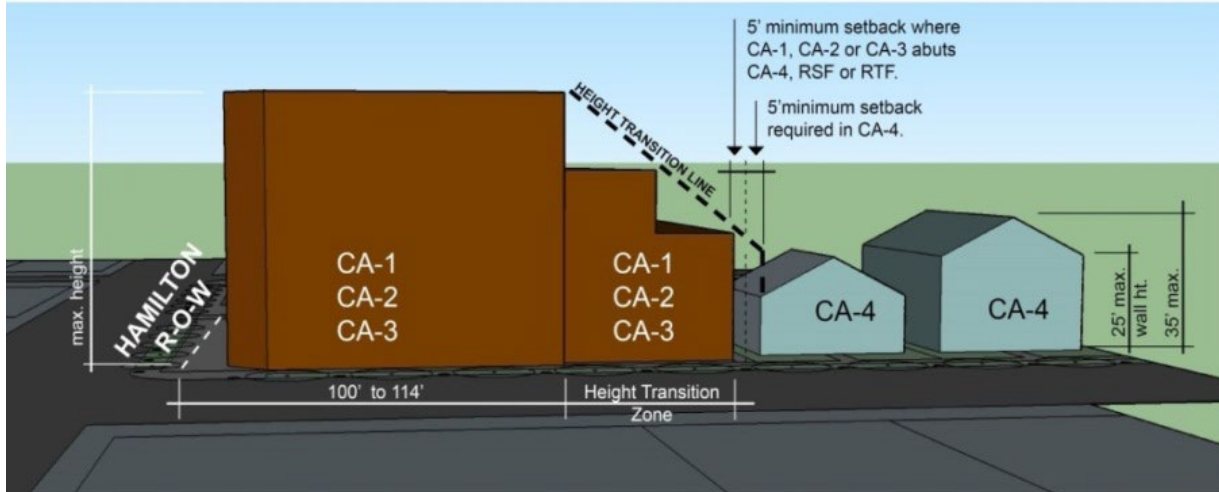

((Figure 17C.123.040A: The maximum height designation for CA-1, CA-2, CA-3 is allowed within 100' to 114' of the Hamilton right of way line to match the platting pattern along Hamilton. Beyond this point, the maximum height may not exceed a transition line to the maximum wall height allowed in the adjacent zone.))

[NOTE: Delete graphic above]

~~((C. Story listings are provided for reference purposes only, expressing typical outcomes for listed heights. Allowable height exceptions apply to the overall distance extending beyond the measured building height, as follows:~~

- ~~1. Pitched roofs may extend above the height limit, but if the space within the pitched roof is habitable, it shall only be used for residential purposes.~~
- ~~2. For flat roofs, Open Roof Structures (pergolas, arbors) and Architectural Roof Structures (turrets, etc.) may extend beyond the height limit by no more than 12'.~~
- ~~3. For flat roofs, enclosed structures (penthouses) may extend above the height limit by no more than 18' from the roof line if set back no less than 20'.~~

~~D. Shopfront Street Provisions.~~

~~Building placement along Shopfront Streets shall prioritize street corner locations, precluding the development of parking, open spaces or other lot features at street corners.~~

~~E. Impervious Surface Coverage.~~

~~Impervious surfaces shall not exceed the maximum impervious surface percentages (calculated on the basis of the lot) specified in Table 17C.123.040-4.))~~

((Table 17C.123.040-1 Impervious Surface Coverage				
	CA-1	CA-2	CA-3	CA-4
Maximum Impervious Surface	90%	80%	70%	50%))

~~((F.—Parking~~

- ~~1.—Off-Street Surface Parking: Off-street surface parking shall not be placed between the street right-of-way and the building fronting the street.~~
- ~~2.—Parking Space and Aisle Dimensions: Standards for parking space and aisle dimension can be found in SMC 17C.230.140.~~
- ~~3.—Bicycle Parking: Requirements for bicycle parking are found in SMC 17C.230.200. Bicycle parking provided in the streetscape can contribute to requirements in SMC 17C.230.200.~~
- ~~4.—Other Provisions: Additional parking requirements are stated in 17C.230 SMC, Parking and Loading. The FBC supersedes the location and amount requirements for parking; these standards are identified for each context area in figures 17.123.040-D through 17.123.040-G.~~

~~G.—Surface parking and site lighting.~~

~~Surface parking lot and site lighting shall contribute to the character and safety of the site and adjacent rights of way, while not disturbing adjacent properties. Surface lot and site lighting shall adhere to the following standards:—~~

- ~~1.—Lighting types — Pedestrian-scale fixtures shall be used for all lighting illuminating required Pedestrian Paths. Vehicle-scale fixtures may be used for general surface lot and site lighting. (See Figure 17C.123.040-B)~~
- ~~2.—Performance — Parking lot and site lighting shall provide adequate night visibility and security by distributing a minimum of two foot-candles to a maximum of six foot-candles of illumination at ground level. All lighting shall be shielded from producing off-site glare, directing light downward and away from adjacent properties.~~
- ~~3.—Driveways/Site Access — Driveway widths shall not exceed 24 feet, and curb cuts shall not exceed 30 feet for combined entry/exits.—~~
- ~~4.—Pedestrian Walkways — Within surface lots containing more than 30 parking stalls, pedestrian-friendly walkways shall be provided between the surface lots and building entrances. Pedestrian Paths shall be not less than five feet wide and be clearly defined, using at least two of the following:—~~
 - ~~a.—Six-inch vertical curbing~~
 - ~~b.—Textured paving, including across vehicle lanes~~

c. ~~Continuous landscaped area at a minimum of 3 feet wide on at least one side of the walkway~~

H. ~~Shopfront Street Provisions – If fronting on a Shopfront Street, above-ground parking structures shall provide continuous ground-level commercial or office spaces and uses along the street, except at ingress and egress points into the structure. (See Figure 17C.123.040-C.)~~

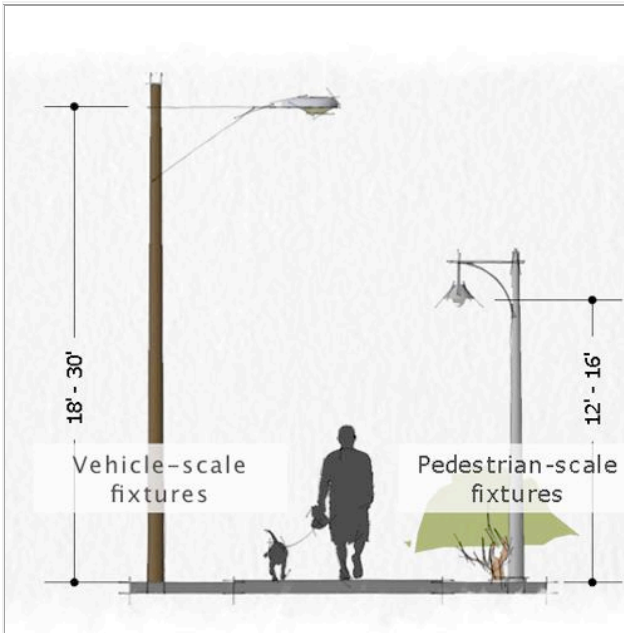

~~((Figure 17C.123.040-B: Unless otherwise specified, Vehicle-Scale and Pedestrian Scale lighting fixtures must meet height criteria illustrated here.))~~

~~[NOTE: Delete graphic above]~~

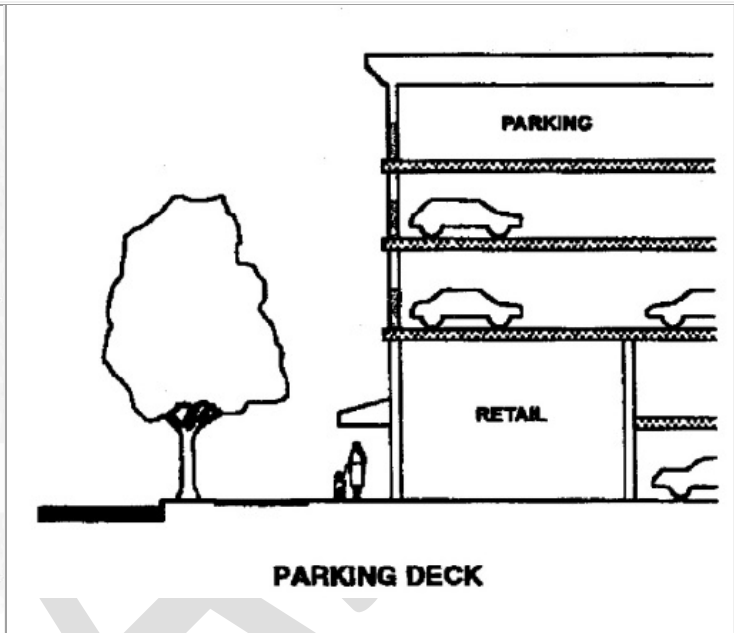

~~((Figure 17C.123.040-C: Parking garages (decks) along shopfront streets must provide ground-level retail, commercial or office space fronting the street.))~~

~~[NOTE: Delete graphic above]~~

~~((I. Regulatory Cutsheets – The information presented in the tables in figures 17.123.040-D through 17.123.040-G represent the regulations for height, parking, land uses, build-to-lines, and building frontage for all Context Areas.~~

~~J. Figure 17C.123.040-H supplements the regulatory cutsheets by providing visual representation for build-to-lines, interior lot lines and other standards.))~~

Figure 17C.123.040-D
Context Area 1 (CA-1)

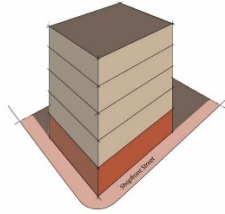

Images above are representational only and are not to be considered regulatory. The Rendering Plan, this chapter's general provisions and the information contained in the table to the right constitute the regulatory framework related to land use, height, parking, build-to-line, coverage and setbacks.

¹Build-to-line shall establish a 12-foot minimum and up to 22' maximum space from the back of the curb to the building along Street Type 1. If existing width is less than 12' structures shall be allowed no closer than 12' from the back of the curb.

Shoptone within 100' 114' of front lot property line	66' (five stories)	Height max.
Beyond 100' 114' Hamilton property line	Transition Standards as identified in 17C.123.060-A	
Maximum surface parking	2 spaces/500 of floor area	Parking
Landscaping	See Section SAC 17C.200	
Location	To side or rear of building	Land uses
Additional Parking Requirements	See Sections: SAC 17C.230.100 SAC 17C.230.120 SAC 17C.230.130 SAC 17C.230.140 SAC 17C.230.200	
Residential, except where prohibited		
Non-residential all floors		
Prohibited uses		
Single-family detached and townhouses		
Minor accessory, storage or warehouse		
Adult businesses		
Residential uses on adjacent street (ground floor)		
Structural parking on shoptone (ground floor)		
Accessory uses		
Drive-through facilities		
Street Type 1	3' min - 12' max ¹	Build-to-line
Street Type 2 and 4	0'	
When within 50' of CA4	0'	Setback from lot line
Street Type 3	Not applicable	
Alley	0'	Building coverage limit
Interior lot line	0'	
Interior lot line if abutting CA-4	0'	
Street Type 1	80%	Building coverage limit
Street Type 2	60%	
Street Type 3	N/A	
Street Type 4	0%	

[NOTE: Delete graphic above]

Figure 17C.123.040-E
Context Area 2 (CA-2)

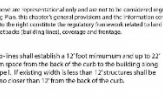
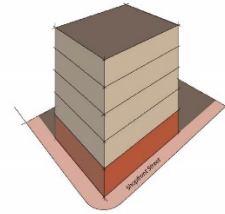

Images above are representational only and are not to be considered regulatory. The Rendering Plan, this chapter's general provisions and the information contained in the table to the right constitute the regulatory framework related to land use, height, parking, setbacks and build-to-line.

¹Build-to-line shall establish a 12-foot minimum and up to 22' maximum space from the back of the curb to the building along Street Type 1. If existing width is less than 12' structures shall be allowed no closer than 12' from the back of the curb.

Shoptone within 100' 114' of front lot property line	66' (five stories)	Height max.
Beyond 100' 114' Hamilton property line	Transition Standards as identified in 17C.123.060-A	
Maximum surface parking	2 spaces/500 of floor area	Parking
Landscaping	See Section SAC 17C.200	
Location	To side or rear of building	Land uses
Additional Parking Requirements	See Sections: SAC 17C.230.100 SAC 17C.230.120 SAC 17C.230.130 SAC 17C.230.140 SAC 17C.230.200	
Residential, except where prohibited		
Non-residential all floors		
Prohibited uses		
Single-family detached and townhouses		
Minor accessory, storage or warehouse		
Adult businesses		
Residential uses on adjacent street (ground floor)		
Structural parking on shoptone (ground floor)		
Accessory uses		
Drive-through facilities		
Street Type 1	3' min - 12' max ¹	Build-to-line
Street Type 2	0'	
Street Type 3	0'	Setback from lot line
Street Type 4	0'	
Alley	0'	Building coverage limit
Interior lot line	0'	
Interior lot line if abutting CA-4	0'	
Street Type 1	80%	Building coverage limit
Street Type 2	60%	
Street Type 3	N/A	
Street Type 4	N/A	

[NOTE: Delete graphic above]

Figure 17C.123.040-F
Context Area 3 (CA-3)

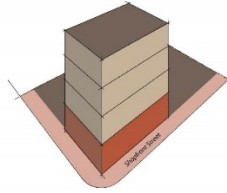

Images above are representational only and are not to be considered regulatory. The Regulatory Plan, this chapter's general provisions and the information contained in the table to the right control the regulatory framework related to land use, height, parking, setbacks, building form, coverage and formage.

¹ Build-to-line shall be a 12-foot minimum and up to 22' maximum space from the back of the curb to the building along Street Type 1. If existing width is less than 12' setbacks shall be allowed no closer than 12' from the back of the curb.

Shoofront of 2 in 100' - 114' of frame from property line	54' (floor slates)	Height max.
Beyond 100' - 114' Shoofront	Transitions Standard as identified in 17C.123.040-A	
Minimum off-street parking	2 spaces/100 of floor area	Parking
Landscaping	Section SMC 17C.200	
Location	To side or rear of building	Land Uses
Additional Parking Requirements	See Sections SMC 17C.200.100 SMC 17C.200.120 SMC 17C.200.140 SMC 17C.200.140 SMC 17C.200.200	
Residential	Residential, except where good-based	Build-to-line
Non-Residential	Non-Residential all floors	
Prohibited uses:	Highly toxic materials and hazardous wastes Aerosol emitters, storage or combustion All air conditioners Required use of night-time sound-attenuating devices Signs and lighting on street front (except for transit) Auto-Restoration Drive Through Facilities	Setback Time
Street Type 1	None - 10' max ¹	
Street Type 2	None - 10' max ¹	Setback Time
Street Type 3, 4	0'	
Alley	0'	Building Formage min.
Interior lot line	0'	
Street Type 1	75%	Building Formage min.
Street Type 2	60%	
Street Type 3	N/A	
Street Type 4	N/A	

[NOTE: Delete graphic above]

Figure 17C.123.040-F
Context Area 4 (CA-4)

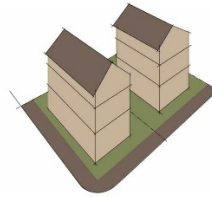

Images above are representational only and are not to be considered regulatory. The Regulatory Plan, this chapter's general provisions and the information contained in the table to the right control the regulatory framework related to land use, height, parking, setbacks, building form, coverage and formage.

¹ Attached garage or carport entrance is required to be setback twenty feet from the property line.

² See SMC 17C.116.200(2)(f) setbacks regarding the use of front yard averaging.

Roof Height	35 feet	Height max.
Wall Height	25 feet	
Minimum off-street parking	1 space/ dwelling unit	Parking
Landscaping	See Section SMC 17C.200	
Location	See Section SMC 17C.200	Land Uses
Additional Parking Requirements	See Sections SMC 17C.200.100 SMC 17C.200.120 SMC 17C.200.140 SMC 17C.200.145	
Residential	Residential (on ground floor)	Build-to-line
Non-Residential	Non-Residential Development shall have a Residential Component from Residential and be no more than 1,000 of floor area	
Prohibited uses:	All industrial categories Parking garage (except attached), auto-repair, auto body, car washing and drive through Alleys Auto-Restoration Drive Through Facilities	Setback Time
Street Type 1	10'	
Street Type 2	10'	Setback Time
Street Type 3	10'	
Street Type 4	10'	Building Formage min.
Alley	0'	
Interior lot line	0'	Building Formage min.
Street Type 1	60%	
Street Type 2	60%	
Street Type 3	None	

[NOTE: Delete graphic above]

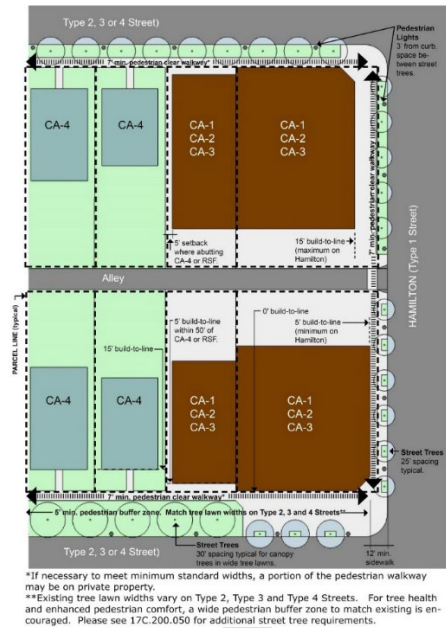

((Figure 17C.123.040-H Visual Diagram))

[NOTE: Delete graphic above]

A. Permitted Uses.

Uses permitted in the residential zones are listed in Table 17C.123.040-1 with a "P." These uses are allowed if they comply with the development standards and other standards of this chapter.

B. Limited Uses.

Uses permitted that are subject to limitations are listed in Table 17C.123.040-1 with an "L." These uses are allowed if they comply with the limitations as listed in the footnotes following the table and the development standards and other standards of this chapter. The paragraphs listed below contain the limitations and correspond with the bracketed [] footnote numbers from Table 17C.123.040-1.

C. Conditional Uses.

Uses that are allowed if approved through the conditional use review process are listed in Table 17C.123.040-1 with a "CU." These uses are allowed provided they comply with the conditional use approval criteria for that use, the development standards, and other standards of this chapter. The conditional use review process and approval criteria are stated in SMC 17C.320, Conditional Uses.

D. Uses Not Permitted.

Uses listed in Table 17C.123.040-1 with an "N" are not permitted. Existing uses in categories listed as not permitted are subject to the standards chapter 17C.210 SMC, Nonconforming Situations.

**Table 17C.123.040-1
Hamilton Form-Based Code Primary Uses**

<u>Use is:</u>	<u>CA1</u>	<u>Shopfront</u>
<u>P – Permitted</u>		
<u>N – Not Permitted</u>		
<u>L – Allowed, but special limitations</u>		
<u>CU – Conditional Use review required</u>		
<u>Residential Categories</u>		
<u>Group Living [1]</u>	<u>L/CU</u>	<u>L/CU</u>
<u>Single-Unit Residential Household Living</u>	<u>N</u>	<u>N</u>
<u>Other Residential Household Living</u>	<u>P</u>	<u>L [2]</u>
<u>Commercial Categories</u>		
<u>Adult Business</u>	<u>N</u>	<u>N</u>
<u>Commercial Outdoor Recreation</u>	<u>N</u>	<u>N</u>
<u>Commercial Parking</u>	<u>N</u>	<u>N</u>
<u>Structured Parking</u>	<u>P</u>	<u>L [3]</u>
<u>Drive-through Facility</u>	<u>N</u>	<u>N</u>
<u>Major Event Entertainment</u>	<u>P</u>	<u>N</u>
<u>Office</u>	<u>P</u>	<u>P</u>
<u>Quick Vehicle Servicing</u>	<u>N</u>	<u>N</u>
<u>Retail Sales and Service</u>	<u>P</u>	<u>P</u>
<u>Mini-storage Facilities</u>	<u>N</u>	<u>N</u>
<u>Vehicle Repair</u>	<u>N</u>	<u>N</u>
<u>Industrial Categories</u>		
<u>High Impact Uses</u>	<u>N</u>	<u>N</u>
<u>Industrial Service</u>	<u>N</u>	<u>N</u>
<u>Manufacturing and Production</u>	<u>N</u>	<u>N</u>
<u>Railroad Yards</u>	<u>N</u>	<u>N</u>
<u>Warehouse and Freight Movement</u>	<u>N</u>	<u>N</u>
<u>Waste-related</u>	<u>N</u>	<u>N</u>
<u>Wholesale Sales</u>	<u>N</u>	<u>N</u>
<u>Institutional Categories</u>		
<u>Basic Utilities</u>	<u>P</u>	<u>N</u>
<u>Colleges [4]</u>	<u>L</u>	<u>L</u>
<u>Community Service</u>	<u>P</u>	<u>P</u>
<u>Daycare</u>	<u>P</u>	<u>P</u>
<u>Medical Center</u>	<u>N</u>	<u>N</u>
<u>Parks and Open Areas</u>	<u>N</u>	<u>N</u>
<u>Religious Institutions</u>	<u>P</u>	<u>P</u>
<u>Schools</u>	<u>P</u>	<u>P</u>
<u>Other Categories</u>		
<u>Agriculture</u>	<u>N</u>	<u>N</u>
<u>Aviation and Surface Passenger Terminals</u>	<u>N</u>	<u>N</u>
<u>Detention Facilities</u>	<u>N</u>	<u>N</u>
<u>Essential Public Facilities</u>	<u>CU</u>	<u>CU</u>

<u>Mining</u>	<u>N</u>	<u>N</u>
<u>Rail Lines and Utility Corridors</u>	<u>N</u>	<u>N</u>
<u>[1] Must comply with the regulations found in SMC 17C.190.100.</u>		
<u>[2] Residential uses are not permitted on the ground floor in Shopfront designated areas.</u>		
<u>[3] Structured parking is not permitted on the ground floor in Shopfront designated areas.</u>		
<u>[4] The accessory uses of housing, retail, and offices are permitted. Lecture halls, food halls, health and sports facilities, laboratories, and other accessory uses not specifically allowed are not permitted within the Hamilton Form-Based Code. Dormitory style housing must comply with the regulations found in SMC 17C.190.100 for group living.</u>		

Section 5. That SMC Section 17C.123.050 is amended to read as follows:

Section 17C.123.050 ((Streetscape Requirements)) Parking and Pedestrian Connectivity

~~((This section identifies features and specifications for commercial and residential streets and alleys within FBC Limits, keyed to the street types identified in the Street Section Plan and to Shopfront Street areas noted on the Regulating Plan. These criteria work to establish the type of active, economically vibrant public realm sought by the community, balancing vehicular access with the safety and convenience of pedestrians and other non-motorized modes of travel.~~

~~A. Streetscape Requirements.~~

~~Required streetscape features and dimensions of those elements are identified in Table 17C.123.050-1.))~~

((Table 17C.123.050-1 Streetscape Requirements [1]					
	Type 1	Type 2	Type 3	Type 4	Alley
Sidewalks					
Overall Width (each side)	12' to 22'	12'	12'	12'	N/A
Type	A	A	A	A	N/A
Clear Pedestrian Zone	7'	7'	7'	7'	N/A
Planting Zone (each side)	5'	5'	5'	5'	N/A
Street Furnishings					
Lighting, types	P [3]	P[3]	P[3]	P[3]	V
Planting, types	S	S/M	S/M	S	N/A
Benches	R	R	R	N/R	N/A
Trash receptacles	R	R	R	N/R	N/A
Bicycle parking	N/R	N/R	N/R	N/R	N/A

~~[1] See City of Spokane Department of Engineering Design Standards for additional specifications.~~

~~[2] Minimum size; Existing tree lawn widths vary on Type 2, 3 and 4 Streets. Additional setbacks, if any, should match existing tree lawn widths in the CA-4 zone. Please see 17C.200 for additional street tree requirements.~~

~~[3] See Figure 17C.123.050-B (below) for Pedestrian Scale Lighting Standards
Parking Stall types: "A" = 8.5' W x 18' L parallel stalls; "B" = 9' W x 16' L angled stalls, back in (60°?)~~

~~Sidewalk types: "A" = 4' x 2' scored concrete~~

~~Lighting types: "P" = Pedestrian scale; "V" = Vehicle scale~~

~~Planting types: "S" = Street trees; "M" = Median planting~~

~~Benches, Trash receptacles, Bicycle parking: "R" = Required; "N/R" = Not required))~~

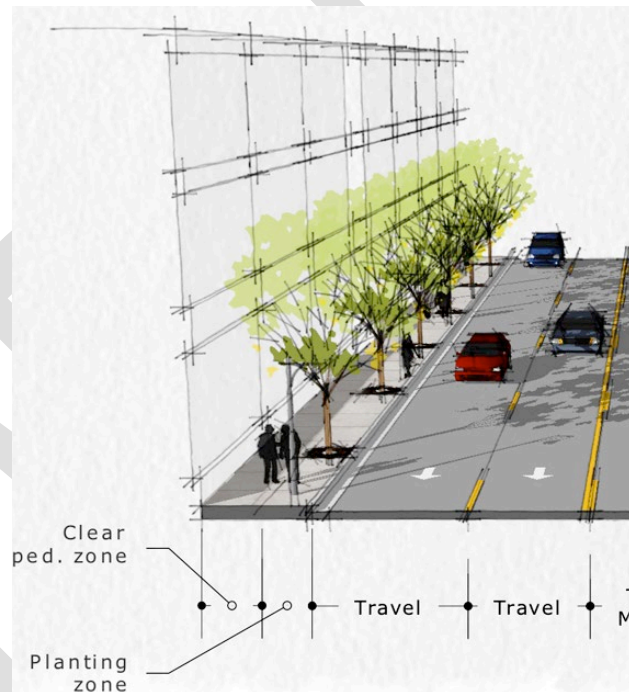

~~((Figure 17C.123.050-A—Desired Frontage Characteristics.))~~

[NOTE: Delete graphic above]

~~((A.—Sidewalks:~~

~~The composition and color of sidewalks shall be as described in Table 17C.123.050-1, and shall be continued as they cross vehicular driveways (See Figure 17C.123.050-E).~~

- ~~1. When the existing sidewalk width is less than 12 feet structures shall be allowed no closer than 12 feet from the back of the curb.~~
- ~~2. When the existing sidewalk width is greater than the bare minimum of 12 feet the sidewalk environment shall be designed to meet the intent of the Street Type designation of the street. Existing sidewalk width shall not be reduced or encroached upon by new development.~~

~~B. Street Furnishings, Placement.~~

~~Street furnishings including light poles, benches, and trash receptacles shall be placed between tree locations within the Planting Zone. Street furnishings shall not impede the clear view triangle. Temporary and intermittent sidewalk encroachments including café seating, planters, ramps, steps, and sandwich board signs may be located in the Planting Zone without restriction, or in the Clear Pedestrian Zone provided a pathway of at least six (6) feet wide remains free of such obstructions (See Figure 17C.123.050-F). Bicycle parking is encouraged where the requirement for the Planting Zone and Clear Pedestrian Zone can be met. Bicycle parking provided in the streetscape can contribute to requirements in SMC 17C.230.200(1)(b). Street furnishings required in Table 17C.123.050-1 are to be provided in all Context Areas as follows:~~

- ~~1. Planting — Street trees must be installed and maintained by the adjacent property in all streets bordering development. Generally, street trees should be spaced on average 25 feet apart. At a minimum, street trees shall provide a continuous row of City-approved trees spaced according to mature canopy size, plus one or more types of City-approved ground cover. Additional requirements for landscaping are stated in chapter 17C.200, Landscaping and Screening.~~
- ~~2. Lighting — City-approved Traditional Series pedestrian scale lighting as shown in Figure 17C.123.050-B (flower basket optional) shall be provided and spaced at an average 50 to 60 feet apart, generally midway between required street trees and centered thirty-six (36") from the curb to ensure a uniform distance from the street edge along the entire street.~~
- ~~3. City approved benches and trash receptacles shall be provided for all buildings larger than 10,000 sf. Buildings less than this size are encouraged to include such amenities.))~~

Hamilton FBC Pedestrian Light Standards

C.1. The City of Spokane Traditional Series pedestrian acorn light (flower basket optional) shall be installed at an average 25' spacing generally spaced midway between street trees and centered thirty-six inches (36") from the curb to ensure a uniform distance from street edge along the entire street.

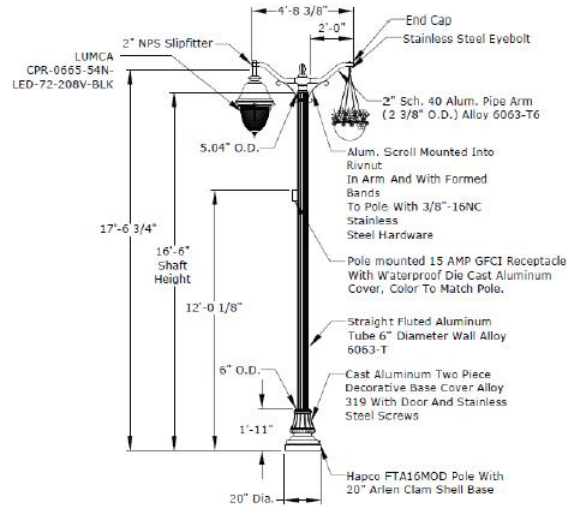

Traditional Series Light Fixture
Not to Scale

~~((Figure 17C.123.050-B))~~

[NOTE: Delete graphic above]



((Figure 17C.123.050-E: Curb cuts and driveways may not interrupt sidewalk material and pattern requirements. Ramps may not encroach on Clear Pedestrian Zones.))

[NOTE: Delete graphic above]



((Figure 17C.123.050-F: Temporary sidewalk encroachments are allowed in the Planting Zone, or in the Clear Pedestrian Zone as per Table 17C.123.050-4.))

[NOTE: Delete graphic above]

The Hamilton Form-Based Code (FBC) establishes parking standards that support pedestrian and vehicular movement within and through the area to provide a safe and convenient environment for transit, walking, biking, and rolling.

A. Dimensional standards and other off-street parking requirements are found in SMC 17C.230.200 unless otherwise modified in this chapter.

B. Minimum Parking.

For all uses within the Hamilton FBC area, there are no minimum vehicular off-street parking spaces.

C. Maximum Parking.

A maximum of 2 spaces for every 500 square feet of floor area is permitted.

D. Parking Location.

1. Off-Street Surface Parking.

a. Off-street surface parking shall not be placed between the street right-of-way and the building fronting the street.

2. Shopfront Designated Areas.

If fronting on a Shopfront designation, above-ground parking structures shall provide continuous ground level commercial or office spaces and uses along the street, except at ingress and egress points into the structure. (See Figure 17C.123.040-A).

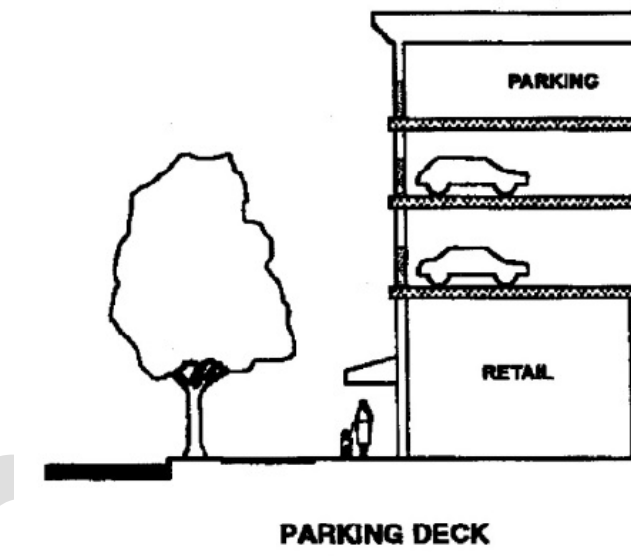

Figure 17C.123.40-A

3. Bicycle Parking.

Requirements for bicycle parking are found in SMC 17C.230.200. Bicycle parking provided in the streetscape can contribute to requirements in SMC 17C.230.200.

4. Site Lighting.

Surface parking lot and site lighting shall contribute to the visibility and safety of the site and adjacent rights-of-way, while not disturbing adjacent properties. Surface lot and site lighting shall adhere to the following standards:

a. Lighting types.

Pedestrian-scale fixtures shall be used for all lighting illuminating required Pedestrian Paths. Vehicle-scale fixtures may be used for general surface lot and site lighting. Lighting shall meet the dimensions of Figure 17C.123.40-B.

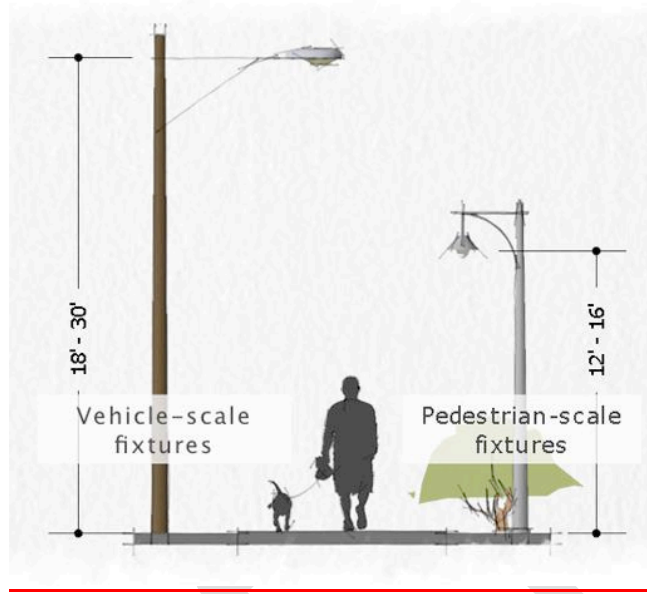

Figure 17C.123.40-B

b. Performance.

Parking lot and site lighting shall provide adequate night visibility and security by distributing a minimum of two foot-candles to a maximum of six foot-candles of illumination at ground level. All lighting shall be shielded from producing off-site glare, directing light downward and away from adjacent properties.

5. Driveways/Site Access.

Driveway widths shall not exceed 24 feet, and curb cuts shall not exceed 30 feet for combined entry/exits.

6. Pedestrian Walkways.

a. Within surface lots containing more than 30 parking stalls, pedestrian-friendly walkways shall be provided between the surface lots and building entrances.

b. Pedestrian Paths shall be not less than five feet wide and be clearly defined, using at least two of the following:

i. Six-inch vertical curbing

ii. Textured paving, including across vehicle lanes

iii. Continuous landscaped area at a minimum of 3 feet wide on at least one side of the walkway.

Section 6. That SMC Section 17C.123.060 is amended to read as follows:

Section 17C.123.060 (~~(Architectural Requirements)~~) Streetscape Requirements

~~((This section identifies general architectural requirements and guidelines, articulating basic façade requirements, roofline objectives, mechanical screening and other considerations. These requirements and guidelines establish important functional and aesthetic characteristics sought by the community and expressed by the Regulating Plan, ensuring the proper “fit” within the surrounding neighborhood.~~

~~A. Building Base.~~

~~For CA-1, CA2, CA3 and all Shopfront Street areas, building façades shall include a visually prominent plinth or base, helping establish pedestrian-scaled features and aesthetically tying the building to the street level. Building bases shall measure between 9” and 16” above adjacent grade, and utilize at least one of the following:~~

- ~~1. “Heavier” material composition, such as a stronger, more permanent material than used on upper portions of the façade.~~
- ~~2. A horizontal projection showing visible thickening of the wall surface that may be accompanied by a change of material and/or color.~~
- ~~3. A horizontal architectural line or feature, such as a belt course or secondary cornice, at or below the top of the first story and providing visual separation between the first two floors (See Figure 17C.123.060-A).~~

~~B. Primary Building Entries.~~

~~For CA-1, CA2, CA3 and all Shopfront Street areas, Primary Building Entries shall face the street and be made visually prominent, including the use of a recommended accent material and at least one of the following:~~

- ~~1. Recessed entrance. Recessed entrance shall be recessed at least 3’ from the building face.~~
- ~~2. Canopy or awning. Canopy or awning shall extend at least 5’ from the building face, with a minimum height clearance of 8’ above the sidewalk.~~
- ~~3. Inclusion of a volume that protrudes from the rest of building surface or an Architectural Roof Structure element physically or visually integrated with the Primary Building Entry (See Figure 17C.123.060-B).~~
- ~~4. For mixed-use buildings, entrances to residential, office or other upper story uses shall be clearly distinguishable in form and location from retail entrances.))~~



~~((Figure 17C.123.060-A: Illustration of building base, pedestrian-scale signs and other building elements described in the FBC.))~~

~~[NOTE: Delete graphic above]~~



~~((Figure 17C.123.060-B: Primary Building Entrances must face the street and be made visually prominent using one or more architectural approaches listed in 17C.123.070-B.))~~

~~[NOTE: Delete graphic above]~~

~~C. Street level Detailing.~~

~~For CA-1, CA2, CA3 and all Shopfront Street areas, street-level façades shall help create a more welcoming, aesthetically rich pedestrian environment by incorporating at least four of the following elements:~~

- ~~1. Canopies or awnings spanning at least 25% of the building façade. Canopy or awning shall extend at least 5' from the building face and shall not be closer than 2' from the curb, with a minimum height clearance of 8' above the sidewalk.~~
- ~~2. Pedestrian-Scaled Signs, mounted to the building or permanent overhang.~~
- ~~3. Decorative sconce, lantern or similar lighting, mounted to the building.~~
- ~~4. Projecting windowsills.~~
- ~~5. Decorative kick plates for entry doors.~~
- ~~6. Hanging planters supported by brackets mounted to the building.~~

~~D. Façade Transparency.~~

~~Building façades shall include substantial glazing, providing visual connectivity between activities inside and outside a building. Regarding glazing, the following provisions shall apply:~~

- ~~1. If fronting along a Shopfront Street, ground floor glazing shall be at least ten feet (10') in height and no more than three feet (3') above adjacent sidewalk or grade.~~
- ~~2. If facing a public street, upper floor façades shall include a minimum of 30% clear glass windows.~~
- ~~3. The total glazing expressed as a minimum percentage of ground floor façades shall meet the specifications provided in Table 17C.123.060-1.~~

Table 17C.123.060-1 Glazing minimums, ground floor facades*				
	CA-1	CA-2	CA-3	CA4
Along Shopfront Street	60%	60%	50%	N/A
Along Non-Shopfront Street	40%	30%	30%	30%
*Glazing percentages may include windows and doors.				

~~E. Blank Walls.~~

~~Minimizing blank or undifferentiated façade walls helps ensure that buildings contribute to an engaging pedestrian environment. In all CA areas, blank façade walls longer than 30' along any public right-of-way shall be enhanced or screened by incorporating the following:~~

- ~~1. Vegetation such as espalier trees and/or vines planted adjacent to the wall surfaces.~~
- ~~2. Architectural detailing, such as reveals, contrasting materials, bas-relief detailing, artwork, murals, or decorative trellises.~~
- ~~3. Roof Lines.~~

~~F. In all CA areas, roofline elements shall adhere to the following standards:~~

- ~~1. Pitched or sloping roofs shall have a minimum slope of 4:12 and a maximum slope of 12:12 (rise:run).~~
- ~~2. Buildings with flat roofs shall include an extended parapet on all building sides, creating a defined cornice or prominent top edge.~~
- ~~3. Non-Enclosed, Enclosed and Architectural Roof Structure elements as defined by this code in are exempt from sections 17C.123.060 F.1 and~~

~~17C.123.060 F.2. Height limitations for such elements are provided in 17C.123.040.~~

~~G. Equipment Screening.~~

~~In all CA zones visible from public rights-of-way, mechanical and electrical equipment including HVAC units, transformers, antennae and receiving dishes shall be screened from view, adhering to the following standards:-~~

- ~~1. Rooftop mechanical and electrical equipment shall be screened by a parapet wall, enclosed within roof volumes or other building elements designed as an integral part of the building's architecture.~~
- ~~2. Ground-level mechanical and electrical equipment shall be enclosed within secondary building elements, or screened by features designed to coordinate with the architectural character of the primary structure. Picket or chain-link fencing may not be used (See Figure 17C.123.060 C).~~

~~H. Service Area Screening.~~

~~In all CA zones, service, loading and trash collection areas shall be hidden or screened from view along public rights-of-way, and shall not face any public street or residential area unless no other location is possible. Service areas shall be hidden from view using a screen wall constructed of masonry, wood or metal, designed to coordinate with the architectural character of the primary structure. Screen walls shall also include one or more of the following:~~

- ~~1. Vegetation such as espalier trees and/or vines planted adjacent to the wall surfaces.~~
- ~~2. Architectural detailing, such as reveals, contrasting materials, bas-relief detailing, artwork, murals, or decorative trellises.~~

~~I. Sign Standards.~~

~~For sign standards applying to all CA zones, see City of Spokane Municipal Code, Chapter 17C.240. For the purposes of signs standards CA1 and CA2 shall be evaluated as CC1 zone; CA3 shall be evaluated as CC2; and CA4 shall be evaluated as a residential zone.~~

~~J. Materials.~~

~~Use of quality building materials ensures that projects contribute to the overall value and character of properties within and adjacent to HFBC Limits. Buildings shall employ durable and high-quality materials, such as steel, glass, brick, stone, and/or wood. (See Figure 17C.123.060 D).))~~

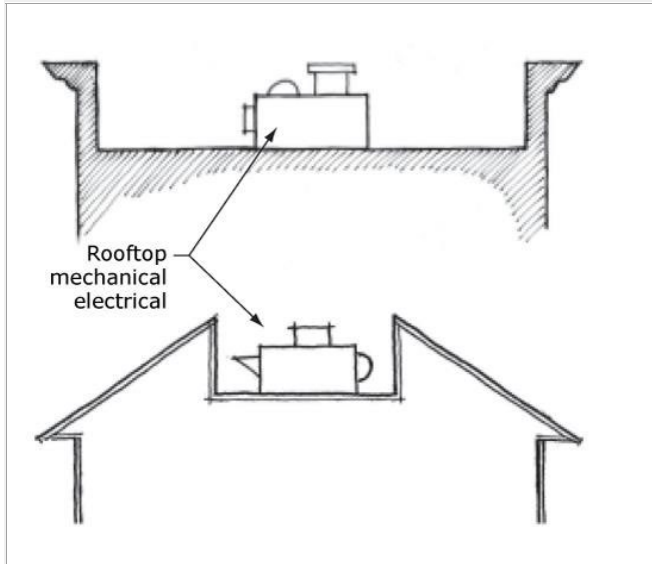

~~((Figure 17C.123.060-C: Rooftop and ground-level equipment must be screened from view along public rights-of-way. Here mechanical systems are hidden by cornice and roof elements.))~~

~~[NOTE: Delete graphic above]~~



~~((Figure 17C.123.060-D: The HFBC provides standards and guidelines regarding building materials, helping realize community expectations for the corridor and neighborhood.))~~

~~[NOTE: Delete graphic above]~~

~~((K.—Guidelines.~~

~~In addition to the material standards defined in this section, the following guidelines are included to further define community expectations for projects within all CA zones within Regulating Plan limits. The guidelines presented in this section are optional and intended to express desirable characteristics for the district.~~

- ~~1.—The use of sustainably harvested, salvaged, recycled/reused products is encouraged wherever possible.~~
- ~~2.—Optional—Recommended entry treatments include special paving materials such as ceramic tile; ornamental ceiling treatments; decorative light fixtures; decorative door pulls, escutcheons, hinges, and other hardware.~~
- ~~3.—Authentic materials and methods of construction should be used to the greatest degree possible. Materials made to simulate higher value materials and construction types may be used for reasons of economy, but should be durable and closely match the proportions, surface finishes, and colors of the materials they simulate.~~

- ~~4. When veneers are used, detailing and installation should give the appearance of full-depth material, avoiding the exposure of veneer sides, including use of wrap-around corner pieces.~~
- ~~5. The location and spacing of panel or expansion joints should be incorporated into the façade composition. Castings should be shaped to form architectural profiles that create bases, cornices, pilasters and other elements contributing to the façade composition.~~
- ~~6. Cladding and/or accent materials on the primary building should be carried over onto additions, accessory buildings and site features.~~
- ~~7. Recommended cladding materials include:
 - ~~a. Brick. Red brick is characteristic of the Spokane region, although other colors may be used as well. Full size brick veneer is preferable to thin brick tile.~~
 - ~~b. Stone. Granite, limestone, sandstone, and river rock are preferred stone types. Stone veneer and cast stone simulating these types is allowable.~~
 - ~~c. Cast concrete. Precast or exposed site-cast structural concrete is acceptable. Pigments, special aggregates and surface textures should be exploited to achieve architectural effects.~~
 - ~~d. Concrete block. Where used, creativity in selecting block sizes, surface textures, course patterns and colors is encouraged.~~
 - ~~e. Wood. Horizontal sidings such as clapboard, tongue-in-groove, shingles or shakes, or vertical sidings such as board and batten are acceptable. Trim elements should be used for all wood siding types. Heavy timber detailing and exposed bracing may be used where appropriate to the building style.~~
 - ~~f. Fiber cement or cementitious siding. Fiber cement planks, panels and shingles and are an acceptable substitute for wood siding when used in the formats described above under "Wood."~~
 - ~~g. Stucco. Stucco, cement plaster or stucco-like finishes such as EIFS may be used along ground floor portions of rear or side service and parking exposures, provided the building base treatment used along the street façade is continued. Stucco of any type should not be used along ground floor portions of street exposures.~~~~

8. ~~Accent materials are typically used at building entrances, window and door frames, wall bases, cornices, wainscot materials and for copings, trim, and other special elements. Recommended accent materials include:~~
 - a. ~~Brick. Red brick is characteristic of the Spokane region, although other colors may be used as well. Full size brick veneer is preferable to thin brick tile.~~
 - b. ~~Stone. Granite, limestone, sandstone, and river rock are preferred stone types. Stone veneer and cast stone simulating these types is allowable.~~
 - c. ~~Cast concrete. Precast or exposed site-cast structural concrete is acceptable. Pigments, special aggregates and surface textures should be exploited to achieve architectural effects.~~
 - d. ~~Concrete block. Where used, creativity in selecting block sizes, surface textures, course patterns and colors is encouraged.~~
 - e. ~~Tile. Ceramic, terra cotta and cementitious tile, whether glazed or unglazed is acceptable.~~
 - f. ~~Metal. Profile, corrugated and other sheet, rolled or extruded metal is acceptable. Metal accents should have trim elements to protect edges, and be of adequate thickness to resist dents and impacts. Surfaces should be treated with a high quality, fade-resistant coating system or paint such as Kynar and Tnemec. Copper, zinc and weathering steel may be left exposed.~~
9. ~~Rooflines. Varied roof planes, cornice elements, overhanging eave and roof decks are encouraged, as they increase visual interest and help implement desired character objectives.~~
10. ~~Recommended materials for roofs exposed and visible from public rights of way include:~~
 - a. ~~Metal seam roofing. Finishes should be anodized, fluoro-coated or painted. Copper, zinc and weathering steel may be left exposed.~~
 - b. ~~Slate or slate-like materials.~~
 - c. ~~Sheet metal shingles.~~
 - d. ~~Asphalt shingles. Projects using asphalt shingles should use the highest quality commercial grade materials, and be provided with adequate trim elements.~~

11. ~~Special Paving. Cobblestones or a stamped concrete cobblestone or brick pattern are recommended for special paving and pedestrian buffer strips~~
12. ~~Frontage Types. Figure 17C.123.060E clarifies expectations for how buildings will meet the street.))~~

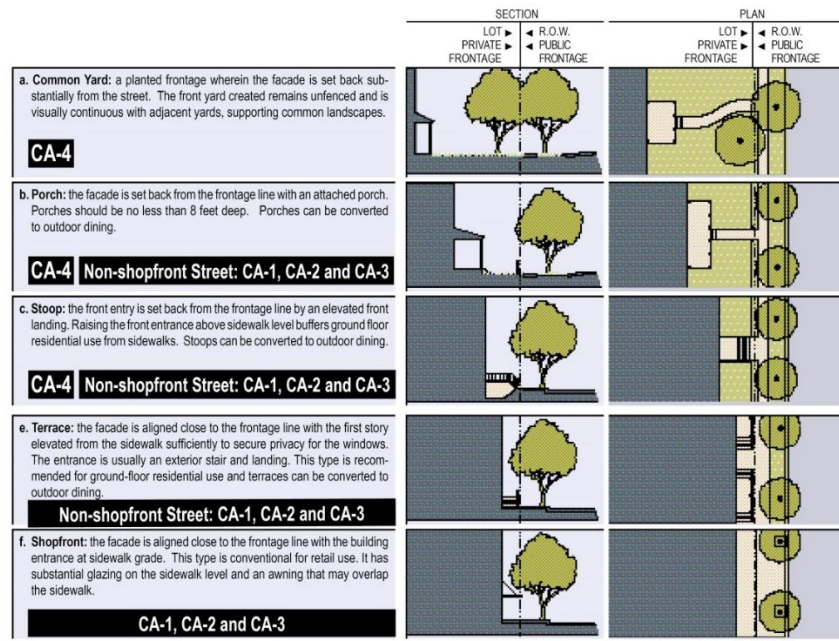

~~((Figure 17C.123.060-E: Frontage Types))~~

[NOTE: Delete graphic above]

This section of the Hamilton Form-Based Code (FBC) identifies features and specifications for area streets and alley. The standards work to establish the type of active, economically vibrant public realm sought by the area community, balancing vehicular access with the safety and convenience of transit, walking, biking, and rolling.

A. Streetscape Requirements.

Required streetscape features and dimensions of those elements are identified in Table 17C.123.050-1.

Table 17C.123.060-1			
Streetscape Requirements [1]			
	CA1	Shopfront	Alley
Sidewalks			
Overall Width (each side)	12 ft.		N/A

Type	4' x 2' scored concrete		N/A
Clear Pedestrian Zone	7 ft. [2]		N/A
Buffer Zone (each side) [3]	5 ft.		N/A
Street Furnishings			
Lighting, types [4]	P	P	V
Planting, types [5]	S	S/M	N/A
Benches [6] [7]	R	R	N/A
Trash receptacles [6] [7]	R	R	N/A
Bicycle parking [6] [7]	N/R	R	N/A
[1] See City of Spokane Department of Engineering Design Standards for additional specifications.			
[2] Along Columbus Street, a 10-foot wide Clear Pedestrian Zone is required.			
[3] A reduced width may be permitted with an approved alternative planting system, such as modular suspended pavement systems, with the approval of Urban Forestry.			
[4] "P" = Pedestrian scale; "V" = Vehicle scale			
[5] "S" = Street trees; "M" = Median planting			
[6] "R" = Required; "N/R" = Not required			
[7] Buildings less than 10,000 sf. are encouraged to include such amenities but are not required.			

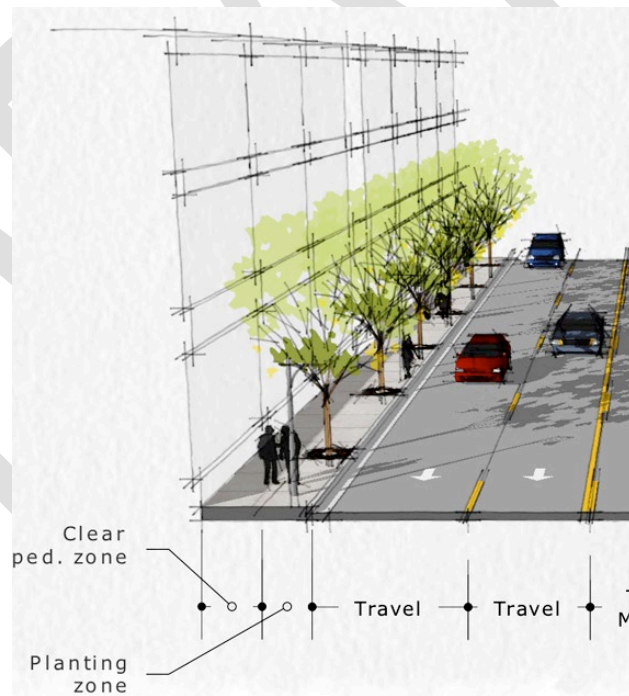

Figure 17C.123.050-A –
Desired Frontage Characteristics.

B. Sidewalks.

The composition and color of sidewalks shall be as described in Table 17C.123.050-1 and shall be continued as they cross-vehicular driveways (See Figure 17C.123.050-B).

1. When the existing sidewalk width is less than 12 feet, structures shall be allowed no closer than 12 feet from the back of the curb.
2. When the existing sidewalk width is greater than the bare minimum of 12 feet, the existing sidewalk width shall not be reduced or encroached upon by new development.

C. Street Furnishings.

Street furnishings including light poles, benches, and trash receptacles shall be placed between tree locations within the Planting Zone. Street furnishings shall not impede the clear view triangle. Street furnishings required in Table 17C.123.050-1 are to be provided as follows:

1. Planting.

Street trees must be installed and maintained by the adjacent property in all streets bordering development. Generally, street trees should be spaced on average 25 feet apart. At a minimum, street trees shall provide a continuous row of City-approved trees spaced according to mature canopy size, plus one or more types of City-approved ground cover. Additional requirements for landscaping are stated in chapter 17C.200 SMC, Landscaping and Screening.

2. Lighting.

City-approved Traditional Series pedestrian scale lighting as shown in Figure 17C.123.050-C (flower basket optional) shall be provided and spaced at an average 50 to 60 feet apart, generally midway between required street trees and centered thirty-six (36") from the curb to ensure a uniform distance from the street edge along the entire street.

Hamilton FBC Pedestrian Light Standards

C.1. The City of Spokane Traditional Series pedestrian acorn light (flower basket optional) shall be installed at an average 25' spacing generally spaced midway between street trees and centered thirty-six inches (36") from the curb to ensure a uniform distance from street edge along the entire street.

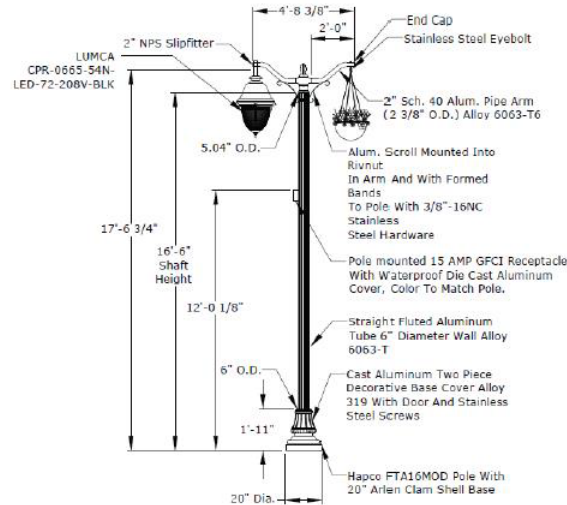

Traditional Series Light Fixture
Not to Scale

Figure 17C.123.050-C

D. Bicycle Parking.

Bicycle parking is encouraged where the requirement for the Planting Zone and Clear Pedestrian Zone can be met. Bicycle parking provided in the streetscape can contribute to requirements in SMC 17C.230.200.

E. Temporary Encroachments.

Temporary and intermittent sidewalk encroachments including café seating, planters, ramps, steps, and sandwich board signs may be located in the Planting Zone without restriction, or in the Clear Pedestrian Zone provided a pathway of at least six (6) feet wide remains free of such obstructions (See Figure 17C.123.050-D).



Figure 17C.123.050-D – Temporary sidewalk encroachments are allowed in the Planting Zone, or in the Clear Pedestrian Zone as per Table 17C.123.050-1.

F. City approved benches and trash receptacles shall be provided for all buildings larger than 10,000 sf. Buildings less than this size are encouraged to include such amenities.

Section 7. That SMC Section 17C.123.070 is amended to read as follows:

Section 17C.123.070 ((Additional Requirements)) Design Standards

~~((A.—Drive Through Facilities:~~

~~Drive-Through Facilities are prohibited in all Context Areas of the FBC.~~

~~B.—Nonconforming Situations:~~

~~Existing development that does not conform to the development standards of this chapter is subject to the standards of chapter 17C.210 SMC, Nonconforming Situations.~~

~~C. Nuisance-related Impacts.~~

- ~~1. Off-site impacts. All nonresidential uses including their accessory uses must comply with the standards of Chapter 17C.220, Off-Site Impacts.~~
- ~~2. Other nuisances are further regulated by state and local laws.~~

~~D. Outdoor Activities~~

- ~~1. The standards of this section are intended to assure that outdoor sales, display, storage, and work activities:~~
 - ~~a. will be consistent with the desired character of the zone;~~
 - ~~b. will not be a detriment to the overall appearance of an area;~~
 - ~~c. will not have adverse impacts on adjacent properties, especially those with residential uses; and~~
 - ~~d. will not have an adverse impact on the environment.~~
- ~~2. Outdoor activities associated with permitted uses shall be permitted subject to the standards of the zone and as described below.~~
- ~~3. Outdoor Sales and Display Areas.~~
 - ~~a. In the CA1—CA3 zones, outdoor sales, and display areas are limited to forty percent of lot area or one thousand five hundred square feet, whichever is less.~~
 - ~~b. Outdoor sales and display areas for uses in the industrial use categories are not allowed in the CA zones.~~
 - ~~c. In the CA 4 zone, outdoor sales and display areas are prohibited.~~
- ~~4. Outdoor Storage Areas.~~
 - ~~a. Outdoor storage areas are not permitted in the CA1—CA3 zones.~~
 - ~~b. Outdoor storage areas in CA4 zones are subject to the standards of SMC 17C.110.270 Exterior Storage—Residential Zones.~~

~~5. Outdoor Activity Area Improvements.~~

- ~~a. Outdoor activities shall be screened and landscaped according to the provisions of chapter 17C.200 SMC, Landscaping and Screening.~~
- ~~b. In order to control dust and mud, all vehicle circulation areas must be paved.~~

~~E. Fences~~

- ~~1. Purpose: The fence standards promote the positive benefits of fences without adversely impacting the community or endangering public or vehicle safety. Fences near streets are kept low in order to allow visibility into and out of the site and to ensure visibility for motorists. Fences in any required side or rear setback are limited in height so as to not conflict with the purpose for the setback.~~
- ~~2. Type of Fences The standards apply to walls, fences, and screens of all types whether open, solid, wood, metal, wire, masonry, or other material.~~
- ~~3. Location, Height, and Design.~~
 - ~~a. Street Setbacks.~~
 - ~~i. No fence or other structure is allowed within twelve feet from the back of the curb, consistent with the required sidewalk width of SMC 17C.123.060.~~
 - ~~ii. Fences up to three and one-half feet high are allowed in a required street setback that is measured from a front lot line.~~
 - ~~iii. Fences up to six feet high are allowed in required setback that is measured from a side lot line.~~
 - ~~iv. Fences shall not reduce the required setback width of SMC 17C.123.060.~~
 - ~~v. Fences up to six feet high are allowed in required side or rear setbacks except when the side or rear setback abuts a pedestrian connection. When the side or rear setback abuts a pedestrian connection, fences are limited to three and one-half feet in height.~~

~~vi. The height for fences that are not in required setbacks is the same as the regular height limits of the zone.~~

~~b. Sight-obscuring Fences and Walls.~~

~~i. Any required or non-required sight-obscuring fences, walls, and other structures over three and one-half feet high, and within fifteen feet of a street lot line shall either be placed on the interior side of a L2 see-through buffer landscaping area at least five feet in depth (See chapter 17C.200 SMC, Landscaping and Screening), or meet the treatment of blank walls intent outlined in SMC 17C.122.060 Initial Design Standards and Guidelines for Center and Corridors.~~

~~4. Prohibited Fences.~~

~~a. No person may erect or maintain a fence or barrier consisting of or containing barbed, razor, concertina, or similar wire except that up to three strands of barbed wire may be placed atop a lawful fence exceeding six feet in height above grade.~~

~~b. No person may maintain a fence or barrier charged with electricity.~~

~~c. A fence, wall, or other structure shall not be placed within a public right-of-way without an approved covenant as provided in SMC 17G.010.160 and any such structure is subject to the height requirement for the adjoining setback.~~

~~d. No permanent fence may reduce the required sidewalk width.~~

~~5. Visibility at Intersections.~~

~~a. A fence, wall, hedge, or other improvement may not be erected or maintained at the corner of a lot so as to obstruct the view of travelers upon the streets~~

~~b. Subject to the authority of the traffic engineer to make adjustments and special requirements in particular cases, no fence exceeding a height of thirty-six inches above the curb may be inside the:~~

~~i. right isosceles triangle having sides of fifty feet measured along the curb line of each intersecting residential street; or~~

~~ii. right triangle having a fifteen-foot side measured along the curb line of the residential street and a seventy-five-foot side along the curb line of the intersecting arterial street, except~~

~~that when the arterial street has a speed limit of thirty-five miles per hour, the triangle has a side along such arterial of one hundred twenty-two feet; or~~

~~iii. right isosceles triangle having sides of seven feet measured along the right-of-way line of an alley and:~~

~~1. the inside line of the sidewalk; or~~

~~2. if there is no sidewalk, a line seven feet inside the curb line.~~

~~6. Enclosures for Pools, Hot Tubs, or Ponds.~~

~~a. A person maintaining a swimming pool, hot tub, pond, or other impoundment of water exceeding five thousand gallons and eighteen inches or more in depth and located on private property is required to construct and maintain an approved fence by which the pool or other water feature is enclosed and inaccessible by small children.~~

~~b. The required pool enclosure must be at least fifty-four inches high and may be a fence, wall, building, or other structure approved by the building services department.~~

~~c. If the enclosure is a woven wire fence, it is required to be built to discourage climbing.~~

~~d. No opening, except a door or gate may exceed four inches in any dimension.~~

~~e. Any door or gate in the pool enclosure, except when part of the occupied dwelling unit, must have self-closing and self-locking equipment by which the door or gate is kept secure when not in use. A latch or lock release on the outside of the door or gate must be at least fifty-four inches above the ground.~~

~~f. Outside of the door or gate must be at least fifty-four inches above the ground.~~

~~7. Reference to Other Standards.~~

~~1. Building permits are required by the building services department for all fences including the replacement of existing fences. A permit is not required to repair an existing fence.~~

~~F. Creation of new lots is subject to the standards of chapter 17G.080 SMC.))~~

All development within the Hamilton Form-Based Code (FBC) must address the following design standards, administered pursuant to SMC 17C.111.015 Design Standards Administration. When existing development is expanded, only those portions of the development that are new or renovated must meet the standards in this section.

This section also includes Guidelines that further define community desires for new development and redevelopment within the Hamilton FBC area. The Guidelines are optional and intended to express the desired built form for the area.

A. Building Base.

Building façades shall include a visually prominent plinth or base, helping establish pedestrian-scaled features and aesthetically tying the building to the street level. Building bases shall measure between 9 inches and 16 inches above adjacent grade, and utilize at least one of the following:

1. A horizontal projection of at least 3 inches that may be accompanied by a change of material and/or color.
2. A horizontal architectural line or feature, such as a belt course or secondary cornice, at or below the top of the first story and providing visual separation between the first two floors (See Figure 17C.123.060-A).



Figure 17C.123.060-A – Illustration of building base, pedestrian scale signs and other building elements described in the FBC.

B. Primary Building Entries.

1. Primary building entries shall face the street and be made visually prominent, including at least one of the following:
 - a. An entrance recessed at least 3' from the building face.
 - b. A canopy or awning that extends at least 5' from the building face, with a minimum height clearance of 8' above the sidewalk.
2. For mixed-use buildings, entrances to residential, office or other upper story uses shall be clearly distinguishable in form and location from retail entrances.

C. Street-level Detailing.

Street-level façades shall help create a more welcoming, aesthetically rich pedestrian environment by incorporating at least four of the following elements:

1. Canopies or awnings spanning at least 25% of the building façade.
2. Canopy or awning shall extend at least 5' from the building face and shall not be closer than 2' from the curb, with a minimum height clearance of 8' above the sidewalk.
3. Pedestrian-Scaled Signs, mounted to the building or permanent overhang.
4. Decorative sconce, lantern, or similar lighting, mounted to the building.
5. Projecting windowsills.
6. Decorative kick plates for entry doors.
7. Hanging planters supported by brackets mounted to the building.

D. Façade Transparency.

Building façades shall include substantial glazing, providing visual connectivity between activities inside and outside a building. Regarding glazing, the following provisions shall apply:

1. If within a Shopfront Designation, ground floor glazing facing a public right-of-way shall be at least ten feet (10') in height and no more than three feet (3') above adjacent sidewalk or grade.
2. The total glazing expressed as a minimum percentage of ground floor façades shall meet the specifications provided in Table 17C.123.060-1.

Table 17C.123.070-1		
Glazing minimums, ground floor facades [1]		
	CA1	Shopfront
<u>Non-Residential – within 10-ft. of the sidewalk</u>	<u>40%</u>	<u>60%</u>

<u>Non-Residential – more than 10-ft. from the sidewalk</u>	<u>15%</u>	<u>15%</u>
<u>Residential</u>	<u>15%</u>	<u>15%</u>
<u>[1] Glazing percentages may include windows and doors.</u>		

E. Ground Floor Residential.

In addition to other standards specific to residential development found within this chapter and in order to increase the privacy of residents and provide an effective transition between the public and private realm, ground floor residential within 10-ft. of a sidewalk shall:

1. Be elevated a minimum of 30 inches from grade, with alternatives approved by the Planning Director to accommodate units meeting residential visitability standards found in SMC 17C.111.600;
2. Incorporate a patio, porch, deck, or stoop with covered entry between the entry and sidewalk; and
3. Integrate L3 Open Area Landscaping, as defined in SMC 17C.200.030 Landscape Types, between the sidewalk and building.

F. Blank Walls.

Minimizing blank or undifferentiated façade walls helps ensure that buildings contribute to an engaging pedestrian environment. Blank façade walls longer than 30' along any public right-of-way shall be enhanced or screened by incorporating the following:

1. Public art such as murals;
2. Vegetation such as espalier trees and/or vines planted adjacent to the wall surfaces;
3. Architectural detailing, such as reveals, contrasting materials, bas-relief detailing, or decorative trellises; or
4. Roof Lines.

G. Roof Lines.

1. Pitched or sloping roofs shall have a minimum slope of 4:12 and a maximum slope of 12:12 (rise:run).
2. Buildings with flat roofs shall include an extended parapet on all building sides, creating a defined cornice or prominent top edge.
3. Non-Enclosed, Enclosed, and Architectural Roof Structure elements as defined by this code are exempt from sections 17C.123.060(G)(1) and 17C.123.060(G)(2). Height limitations for such elements are provided in Table 17C.123.030-1.

H. Equipment Screening.

Mechanical and electrical equipment including HVAC units, transformers, antennae and receiving dishes visible from public rights-of-way shall be screened from view, adhering to the following standards:

1. Rooftop mechanical and electrical equipment shall be screened their full height by a parapet wall, enclosed within roof volumes or other building elements designed as an integral part of the building's architecture.
2. Ground-level mechanical and electrical equipment shall be enclosed within secondary building elements or screened by features designed to coordinate with the architecture of the primary structure. Year-round vegetative screening the height of the equipment at planting is permitted. Picket or chain-link fencing may not be used (See Figure 17C.123.060-B).

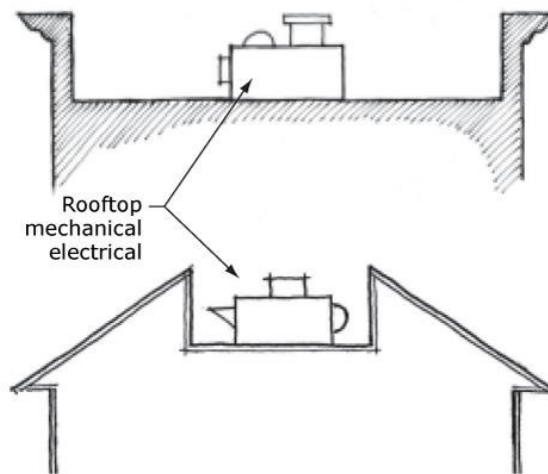

Figure 17C.123.060-B – Rooftop and ground-level equipment must be screened from view along public rights-of-way. Here mechanical systems are hidden by cornice and roof elements.

I. Service Area Screening.

Service, loading, and trash collection areas shall be hidden or screened from view along public rights-of way and shall not face any public street or residential area unless no other location is possible. Service areas shall be hidden from view using a screen wall constructed of masonry, wood, or metal, designed to coordinate with the architecture of the primary structure. Screen walls shall also include one or more of the following:

1. Vegetation such as espalier trees and/or vines planted adjacent to the wall surfaces.
2. Architectural detailing, such as reveals, contrasting materials, bas-relief detailing, or decorative trellises.
3. Public art such as murals.

J. Sign Standards.

See City of Spokane Municipal Code, Chapter 17C.240 for sign standards. Signs within the CA zone are subject to the standards and guidelines contained in the Initial Design Standards and Guidelines for Centers and Corridors.

- K. Swimming pool, hot tub, pond, or other impoundment of water exceeding five thousand gallons and eighteen inches or more in depth must be located within a fully enclosed building.

L. Guidelines.

In addition to the material standards defined in this section, the following guidelines are included to further define community expectations for projects within the Hamilton FBC area. The guidelines presented in this section are optional and intended to express desirable characteristics for the district.

1. Sustainable Design.

- a. The use of sustainably harvested, salvaged, recycled, and reused products is encouraged wherever possible.
- b. The rehabilitation of older buildings should be considered before new construction. If removal is required, the deconstruction of existing development is encouraged.
- c. Integration of Green Stormwater Infrastructure (GSI) should be considered in conjunction with property redevelopment.
- d. Property owners are encouraged to replace or reduce ground cover like grass lawns and pavement with native and/or drought tolerant plantings.
- e. The installation and maintenance of green roofs is encouraged.

2. Trail-Oriented Development.

For properties along the Centennial Trail, development is encouraged to orient towards the trail, which can be accomplished by:

- a. Having patios and decks that overlook the trail.
- b. Having an increased level of façade transparency to increase “eyes on the trail”.
- c. Having a covered entry facing the trail.

d. Avoiding tall fences and blank walls facing the trail.

3. Building Entries.

Recommended entry treatments include special paving materials such as ceramic tile; ornamental ceiling treatments; decorative light fixtures; decorative door pulls, escutcheons, hinges, and other hardware.

4. Building Materials.

a. Authentic materials and methods of construction should be used to the greatest degree possible. Materials made to simulate higher-value materials and construction types may be used for reasons of economy, but should be durable and closely match the proportions, surface finishes, and colors of the materials they simulate.

b. When veneers are used, detailing and installation should give the appearance of full-depth material, avoiding the exposure of veneer sides, including the use of wrap-around corner pieces.

c. Cladding and/or accent materials on the primary building should be carried over onto additions, accessory buildings, and site features.

d. Recommended cladding materials include:

i. Brick. Red brick is characteristic of the Spokane region, although other colors may be used as well. Full size brick veneer is preferable to thin brick tile.

ii. Stone. Granite, limestone, sandstone, and river rock are preferred stone types. Stone veneer and cast stone simulating these types is allowable.

iii. Cast concrete. Precast or exposed site-cast structural concrete is acceptable. Pigments, special aggregates, and surface textures should be exploited to achieve architectural effects.

iv. Concrete block. Where used, creativity in selecting block sizes, surface textures, course patterns and colors is encouraged.

v. Wood. Horizontal sidings such as clapboard, tongue-in-groove, shingles or shakes, or vertical sidings such as board and batten are acceptable. Trim elements should be used for all wood siding types. Heavy timber detailing and exposed bracing may be used where appropriate to the building style.

vi. Fiber-cement or cementitious siding. Fiber-cement planks, panels and shingles and are an acceptable substitute for

wood siding when used in the formats described above under "Wood."

- vii. Stucco. Stucco, cement plaster or stucco-like finishes such as EIFS may be used along ground floor portions of rear or side service and parking exposures, provided the building base treatment used along the street façade is continued. Stucco of any type should not be used along ground floor portions of street exposures.
- e. Accent materials are typically used at building entrances, window and door frames, wall bases, cornices, wainscot materials and for copings, trim, and other special elements. Recommended accent materials include:
 - i. Brick. Red brick is characteristic of the Spokane region, although other colors may be used as well. Full size brick veneer is preferable to thin brick tile.
 - ii. Stone. Granite, limestone, sandstone, and river rock are preferred stone types. Stone veneer and cast stone simulating these types is allowable.
 - iii. Cast concrete. Precast or exposed site-cast structural concrete is acceptable. Pigments, special aggregates and surface textures should be exploited to achieve architectural effects.
 - iv. Concrete block. Where used, creativity in selecting block sizes, surface textures, course patterns and colors is encouraged.
 - v. Tile. Ceramic, terra cotta and cementitious tile, whether glazed or unglazed is acceptable.
 - vi. Metal. Profile, corrugated and other sheet, rolled or extruded metal is acceptable. Metal accents should have trim elements to protect edges, and be of adequate thickness to resist dents and impacts. Surfaces should be treated with a high quality, fade-resistant coating system or paint such as Kynar and Tnemec. Copper, zinc and weathering steel may be left exposed.
- f. The location and spacing of panel or expansion joints should be incorporated into the façade composition. Castings should be shaped to form architectural profiles that create bases, cornices, pilasters and other elements contributing to the façade composition.

5. Rooflines.

Varied roof planes, cornice elements, overhanging eave and roof decks are encouraged, as they increase visual interest and help implement desired character objectives.

a. Recommended materials for roofs exposed and visible from public rights of way include:

i. Metal seam roofing. Finishes should be anodized, fluoro-coated or painted. Copper, zinc and weathering steel may be left exposed.

ii. Slate or slate-like materials.

iii. Sheet metal shingles.

iv. Asphalt shingles. Projects using asphalt shingles should use the highest quality commercial grade materials and be provided with adequate trim elements.

6. Special Paving.

Cobblestones or a stamped concrete cobblestone or brick pattern are recommended for special paving and pedestrian buffer strips.

Section 8. That SMC Section 17C.123.080 is amended to read as follows:

Section 17C.123.080 ((~~Building Type Catalogs~~)) Additional Requirements

A. Outdoor Activities

The standards of this section are intended to assure that outdoor sales, display, storage, and work activities will not have adverse impacts on adjacent properties or the environment, while providing the envisioned built form within the area.

1. Outdoor Sales and Display Areas.

a. Outdoor sales and display areas are limited to forty percent of lot area or one thousand five hundred square feet, whichever is less, in the CA1 zone.

b. Outdoor sales and display areas for uses in the industrial use categories are not allowed in the CA1 zone.

c. In the Shopfront designations, accessory outdoor sales are permitted so long as the Clear Pedestrian Zone and Buffer Zone is maintained.

d. In the Shopfront designations, outdoor display areas are prohibited.

2. Outdoor Storage Areas.

a. Outdoor storage areas are not permitted.

3. Outdoor Activity Area Improvements.

- a. Outdoor activities shall be screened and landscaped according to the provisions of chapter 17C.200 SMC, Landscaping and Screening.
- b. In order to control dust and mud, all vehicle circulation areas must be paved.

B. Fences.

The fence standards avoid adverse impacts on the area while protecting public or vehicle safety. Fences near streets are kept low in order to allow visibility into and out of the site and to ensure visibility for motorists. Fences in any required side or rear setback are limited in height so as to not conflict with the purpose for the setback.

1. Type of Fences.

The standards apply to walls, fences, and screens of all types whether open, solid, wood, metal, wire, masonry, or other material.

2. Location, Height, and Design

a. Street Setbacks.

- i. No fence or other structure is allowed within twelve feet from the back of the curb, consistent with the required sidewalk width of SMC 17C.123.050.
- ii. Fences up to three and one-half feet high are allowed in a required street setback.
- iii. Fences up to six feet high are allowed in required side or rear setbacks except when the side or rear setback abuts a pedestrian connection. When the side or rear setback abuts a pedestrian connection, fences are limited to three and one-half feet in height.
- iv. Fences shall not reduce the required setback width of SMC 17C.123.030.

b. Sight-obscuring Fences and Walls.

- i. Any required or non-required sight-obscuring fences, walls, and other structures over three and one-half feet high, and within fifteen feet of a street lot line shall either be placed on the interior side of a L2 see-through buffer landscaping area at least five feet in depth (See chapter 17C.200 SMC, Landscaping and Screening), or meet the treatment of blank

walls intent outlined in SMC 17C.122.060 – Initial Design Standards and Guidelines for Center and Corridors.

c. Fencing Material.

- i. Fence materials within the public right-of-way or within eight feet of a street lot line should be wrought iron or similar in appearance, aluminum, metal, or similar material.
- ii. Walls visible from streets shall be masonry, stone, brick, or similar construction.
- iii. Chain link fencing is not allowed that is visible from and/or adjacent to a public street.

3. Prohibited Fences.

- a. No person may erect or maintain a fence or barrier consisting of or containing barbed, razor, concertina, or similar wire.
- b. No person may maintain a fence or barrier charged with electricity.
- c. A fence, wall, or other structure shall not be placed within a public right-of-way without an approved covenant as provided in SMC 17G.010.160 and any such structure is subject to the height requirement for the adjoining setback.
- d. No permanent fence may reduce the required sidewalk width.

4. Visibility at Intersections.

A fence, wall, hedge, or other improvement may not be erected or maintained at the corner of a lot so as to obstruct the view of travelers upon the streets.

- 6. Subject to the authority of the traffic engineer to make adjustments and special requirements in particular cases, no fence exceeding a height of thirty-six inches above the curb may be located within the Clear View Triangle, as defined in Section 17A.020.030 “C” Definitions.

Context Area 1 (CA-1)

Hamilton FBC Building Character Visual Catalog

This visual catalog showcases the type, form, and general character of desired development within Context Area 1. Images are representational only.



CA-1 Non-Shopfront

See also CA-2, CA-3 and CA-4 Non-Shopfront.



CA-1 Corner

See also CA-2 and CA-3 Corner.



CA-1 Shopfront

See also CA-2 and CA-3 Shopfront.



CA-1 - 1 to 5 Story Buildings

[NOTE: Delete graphic above]

Context Area 2 (CA-2)

Hamilton FBC Building Character Visual Catalog

This visual catalog showcases the type, form, and general character of desired development within Context Area 2. Images are representational only.



CA-2 Non-Shopfront

See also CA-3 and CA-4 Non-Shopfront.



CA-2 Corner

See also CA-3 Corner.

CA-2 Shopfront

See also CA-3 Shopfront.



CA-2 - 1 to 4 Story Buildings

[NOTE: Delete graphic above]

Context Area 3 (CA-3)

Hamilton FBC Building Character Visual Catalog

This visual catalog showcases the type, form, and general character of desired development within Context Area 3. Images are representational only.



CA-3 Non-Shopfront

See also CA-4.



CA-3 Corner



CA-3 Shopfront



CA-3 - 1 to 2 Story Buildings

[NOTE: Delete graphic above]

Context Area 4 (CA-4)

Hamilton FBC Building Character Visual Catalog

This visual catalog showcases the type, form, and general character of desired development within Context Area 4. Images are representational only.

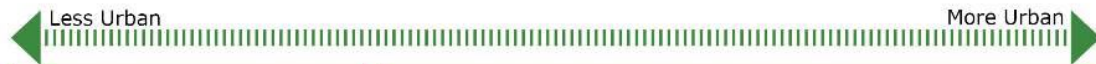

CA-4 Small Footprint



CA-4 Medium Footprint



[NOTE: Delete graphic above]

Context Area 4 (CA-4)

Hamilton FBC Building Character Visual Catalog

This visual catalog showcases the type, form, and general character of desired development within Context Area 4. Images are representational only.



CA-4 Large Footprint



Image borrowed from daybreakutah.com



Image borrowed from daybreakutah.com

[NOTE: Delete graphic above]

17C.111.230/17C.120.220 HEIGHT

The proposed Spokane Municipal Code Text Amendments related to building height are citywide and not limited to the South Logan Project Area. The citywide changes implement recommendations from the [South Logan TOD Plan](#), with citywide implementation ensuring consistency of height and height transitions throughout Spokane. The proposal includes replacing the allowed height of 70-feet with 75-feet to better permit podium-style development, as well as reducing the distance of and modifying the slope of required height transitions adjacent to R1 and R2 zones in order to increase the feasibility of development building to the allowed maximum height allowances.

Text with (~~strikethrough~~) is proposed to be repealed/modified with underlined text representing proposed text. Text without a strikethrough or underline is existing and not proposed to be modified.

Section 1. That SMC Section 17C.111.230 is amended to read as follows:

17C.111.230 Height

A. Purpose.

The height standards promote a reasonable building scale and relationship of one residence to another and they promote privacy for neighboring properties. The standards contained in this section reflect the general building scale and placement of houses in the City's neighborhoods.

B. Height Standards.

The maximum height standards for all structures are stated in Table 17C.111.205-2. The building height shall be measured using the following method (see Figure 17C.111.230-A):

1. Building height is the vertical distance from the average grade to the highest point of the roof or structure that is not listed as an exception to the maximum building height limits as listed in Section 17C.111.230(C).
2. Underground portions of the structure are not included in height calculations. The height of the structure shall be calculated from the point at which the sides meet the surface of the ground.
3. "Average grade" means the average of the ground level adjoining the building at all exterior walls. Where the ground level slopes away from the exterior walls, the reference point shall be established by the lowest points within the area between the building and the lot line or where the lot line is

more than 6 feet from the building, use the reference point between the structure and a point 6 feet from the building.

4. Measurements shall be taken at the existing grade or finished grade, whichever is lower.
5. Depressions such as window wells, stairwells for exits required by other codes, “barrier free” ramps on grade, and vehicle access driveways into garages shall be disregarded in determining structure height when in combination they comprise less than fifty percent of the facade on which they are located. In such cases, the grade for height measurement purposes shall be a line between the grades on either side of the depression.

FIGURE 17C.110.230-A: Height Measurement

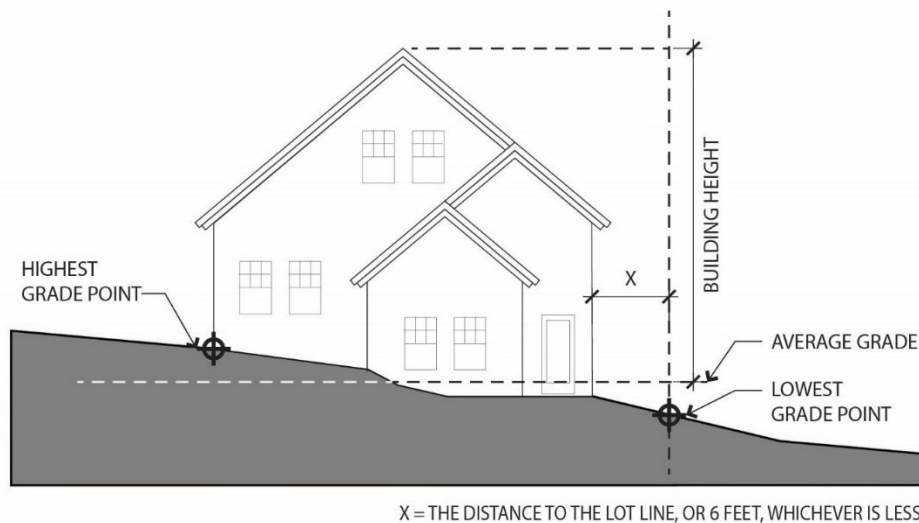

Figure 17C.111.230-A Height Measurement

6. For purposes of measuring building height in residential zones, the following terms shall be interpreted as follows:
 - a. “Grade” means the ground surface contour (see also “existing grade” and “finished grade”).
 - b. “Fill” means material deposited, placed, pushed, pulled or transported to a place other than the place from which it originated.

- c. "Finished grade" means the grade upon completion of the fill or excavation.
- d. "Excavation" means the mechanical removal of earth material.
- e. "Existing grade" means the natural surface contour of a site, including minor adjustments to the surface of the site in preparation for construction.

C. Exceptions to the maximum height standard are stated below:

- 1. Exceptions to the maximum structure height in the RMF and RHD zones are designated on the official zoning map by a dash and a height listed after the zone map symbol (i.e., RHD-150). Changes to the height limits in the RMF and RHD zones require a rezone. Height limits are forty feet, fifty-five feet, (~~seventy feet~~) seventy-five feet, or one hundred fifty feet depending on location.

~~((2. In RMF and RHD zones where the maximum structure height is forty feet, pitched roof structures are allowed an additional fifteen feet above the maximum height standard stated in Table 17C.111.205-2, provided that the roof incorporates all of the following:~~

- ~~a. pitched roof forms having slopes between 4:12 and 12:12; and~~
- ~~b. a minimum of one roof plane that intersects the maximum height plane (see Figure 17C.111.230-B for eligible examples); and~~
- ~~c. establishes sense of "top" per SMC 17C.111.455.))~~

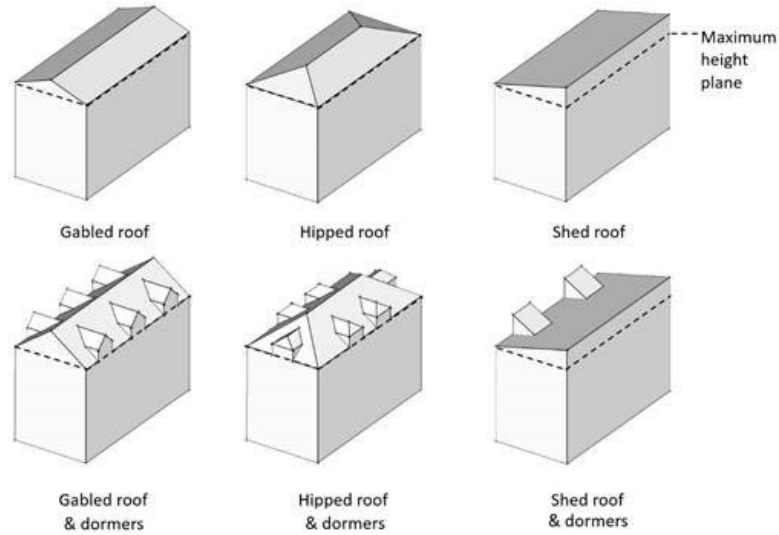

~~((Figure 17C.111.230-B: Roof Type Examples for Height Exception))~~

[NOTE: Delete graphic above]

~~((3))~~2. In the RMF and RHD zones, height does not include up to three feet of the above-grade portions of basement parking, where the elevation of the first residential finished floor is three feet or less above the lowest elevation of the existing grade or finished grade, whichever is lower. See Figure ~~((17C.111.230-C))~~ 17C.111.230-B.

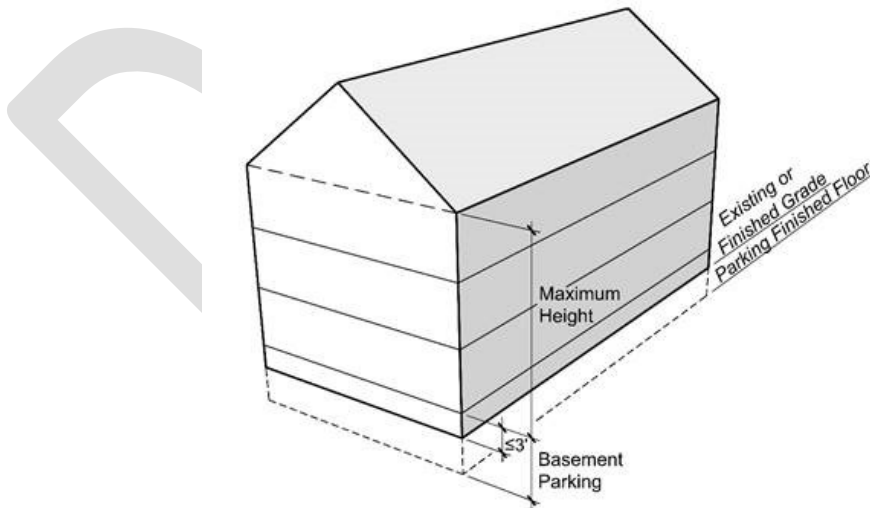

Figure ~~((17C.111.230-C))~~ 17C.111.230-B: Basement Parking Excluded from Height

~~((4))~~3. Buildings and structures over fifty feet in height must follow the design, setback and dimensional standards found in [chapter 17C.250 SMC](#), Tall Building Standards

~~((5))~~4. Adjacent to R1 and R2 Zones.

To provide a gradual transition and enhance the compatibility between the more intensive commercial zones and adjacent R1 and R2 residential zones:

a. For all development within ~~((one hundred fifty))~~ forty feet of any R1 or R2 residential zone the maximum building height is as follows:

i. Starting at a height of ~~((thirty))~~ forty feet ~~((the residential zone boundary))~~ at R1 and R2 property boundaries, additional building height may be added at a ratio of ~~((one))~~ 2 to ~~((two))~~ 1 ~~((one-foot))~~ two feet of additional building height for every ~~((two feet))~~ one foot of additional horizontal distance from the closest ~~((single-family))~~ R1 or ~~((two-family))~~ R2 ~~((residential-zone))~~ zoned property. ~~((The building height transition requirement ends one hundred fifty feet from the R1 or R2 residential zone and then full building height allowed in the zone applies.))~~

ii. The building height transition requirement ends forty feet from the R1 or R2 zoned property line and then full building height allowed in the zone applies.

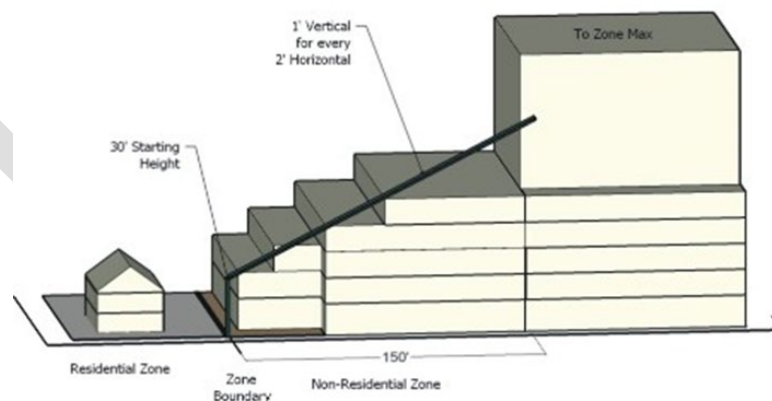

[NOTE: Delete graphic above]

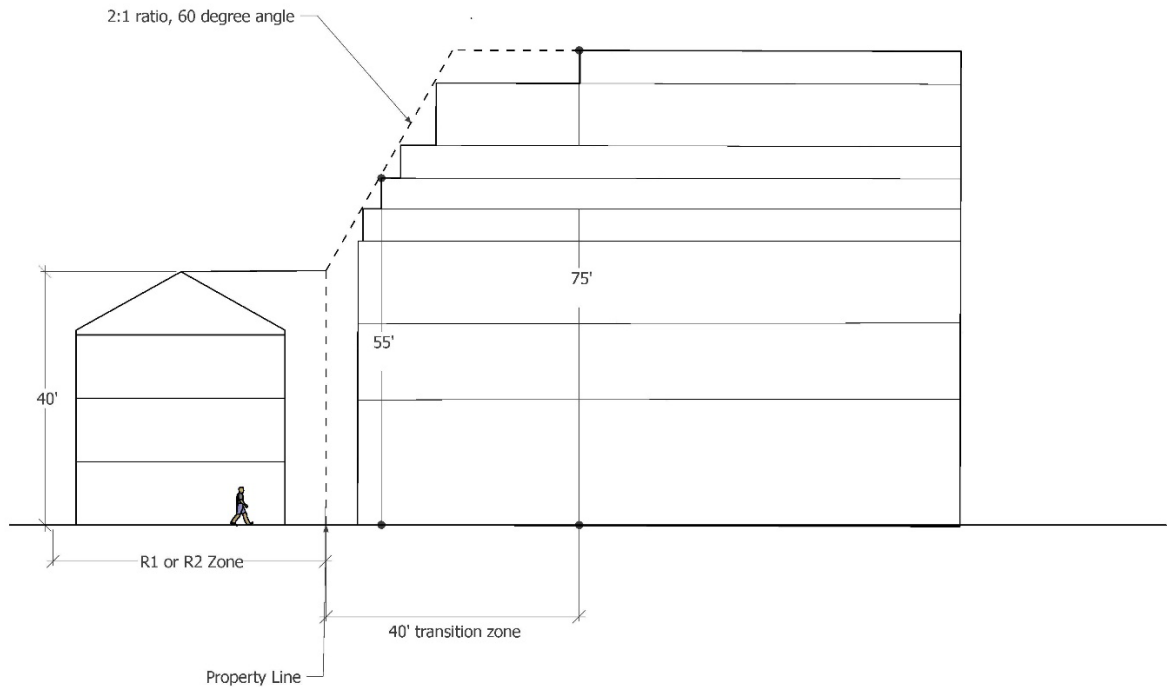

Figure 17C.111.230-C: Height Transition

~~((6. In the RMF zone within forty feet of a common boundary with a R1 zone, the maximum height is forty feet.))~~

~~((7))~~ 5. Projections Allowed.

Chimneys, flagpoles, satellite receiving dishes and other similar items with a width, depth or diameter of three feet or less may extend above the height limit, as long as they do not exceed three feet above the top of the highest point of the roof. If they are greater than three feet in width, depth or diameter, they are subject to the height limit.

~~((8))~~ 6. In addition to the projections allowed under subsection (7) above, in the RMF and RHD zones, the following projections above the roof height are allowed:

- a. Parapets and rooftop railings may extend four feet above the height limit.
- b. Walls or fences located between individual rooftop decks may extend six feet above the height limit if the wall or fence is set back at least four feet from the edges of the roof.

- c. Stairway enclosures that provide rooftop access and cumulatively cover no more than ten percent of the roof area may extend up to ten feet above the height limit, provided that the enclosures are setback at least fifteen feet from all roof edges on street facing facades.

~~((9))~~7. Farm Buildings.

Farm buildings such as silos, elevators and barns are exempt from the height limit as long as they are set back from all lot lines at least one foot for every foot in height.

- ~~((10))~~8. Utility power poles and public safety facilities are exempt from the height limit.

- ~~((14))~~9. Radio and television antennas are subject to the height limit of the applicable zoning category.

- ~~((12))~~10. Wireless communication support towers are subject to the height requirements of [chapter 17C.355A SMC](#), Wireless Communication Facilities.

- ~~((13))~~11. Uses approved as a conditional use may have building features such as a steeple or tower which extends above the height limit of the underlying zone. Such building features must set back from the side property line adjoining a lot in a residential zone a distance equal to the height of the building feature or one hundred fifty percent of the height limit of the underlying zone, whichever is lower.

D. Special Height Districts.

Special height districts are established to control structure heights under particular circumstances such as preservation of public view or airport approaches. See [chapter 17C.170 SMC](#), Special Height Overlay Districts.

E. Accessory Structures.

The height of any accessory structure located in the rear yard, including those attached to the primary residence, is limited to twenty feet in height, except a detached ADU above a detached accessory structure may be built to twenty-five (25) feet in height.

Section 2. That SMC Section 17C.120.220 be amended to read as follows:

17C.120.220 Height

A. Purpose

The height limits are intended to control the overall scale of buildings. The height limits in the O, NR and NMU zones discourage buildings that visually dominate adjacent residential areas. The height limits in the OR, CB and GC zones allow for a greater building height at a scale that generally reflects Spokane's commercial areas. Light, air and the potential for privacy are intended to be preserved in single-family residential zones that are close to commercial zones.

B. Height Standards

The height standards for all structures are stated in [Table 17C.120-2](#). Exceptions to the maximum height standard are stated below.

1. Maximum Height.

Exceptions to the maximum structure height are designated on the official zoning map by a dash and a height listed after the zone map symbol (i.e., CB-150). Changes to the height limits require a rezone. Height limits are ~~((thirty-five feet,))~~ forty feet, fifty-five feet, ~~((seventy feet))~~ seventy-five feet, or one hundred fifty feet depending on location.

2. Buildings and structures over fifty feet in height must follow the design, setback and dimensional standards found in [chapter 17C.250 SMC](#), Tall Building Standards.

3. Adjacent to ~~((Single-family))~~ R1 and ~~((Two-family Residential))~~ R2 Zones.

To provide a gradual transition and enhance the compatibility between the more intensive commercial zones and adjacent ~~((single-family))~~ R1 and ~~((two-family))~~ R2 residential zones:

a. For all development within one hundred fifty feet of ~~((any single-family or two-family residential zone))~~ R1 or R2 zoned properties the maximum building height is as follows:

i. Starting at a height of ~~((thirty))~~ forty feet at ~~((the residential zone boundary))~~ R1 and R2 property boundaries, additional building height may be added at a ratio of ~~((4))~~ 2 to ~~((2))~~ 1 ~~((one-foot))~~ two feet of additional building height for every ~~((two-feet))~~ one foot of additional horizontal distance from the closest ~~((single-family))~~ R1 or ~~((two-family))~~ R2 ~~((residential zone))~~ zoned property line. ~~((The building height transition~~

requirement ends one hundred fifty feet from the single-family or two-family residential zone and then full building height allowed in the zone applies.))

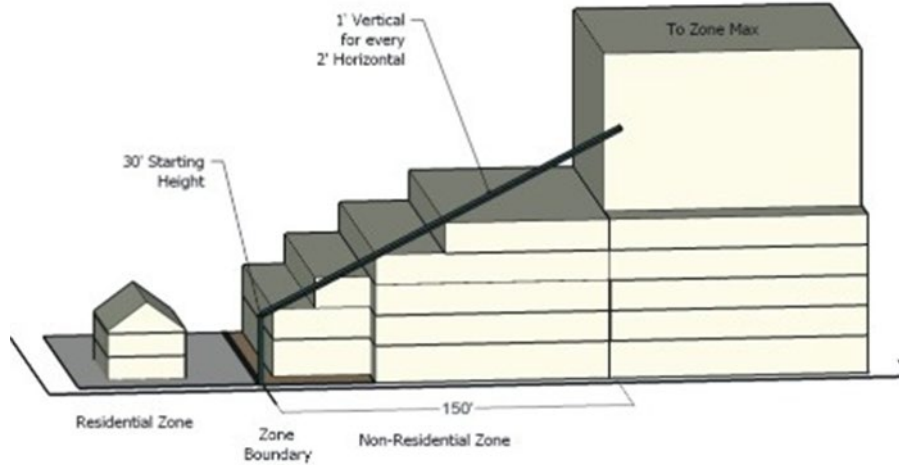

[NOTE: Delete graphic above]

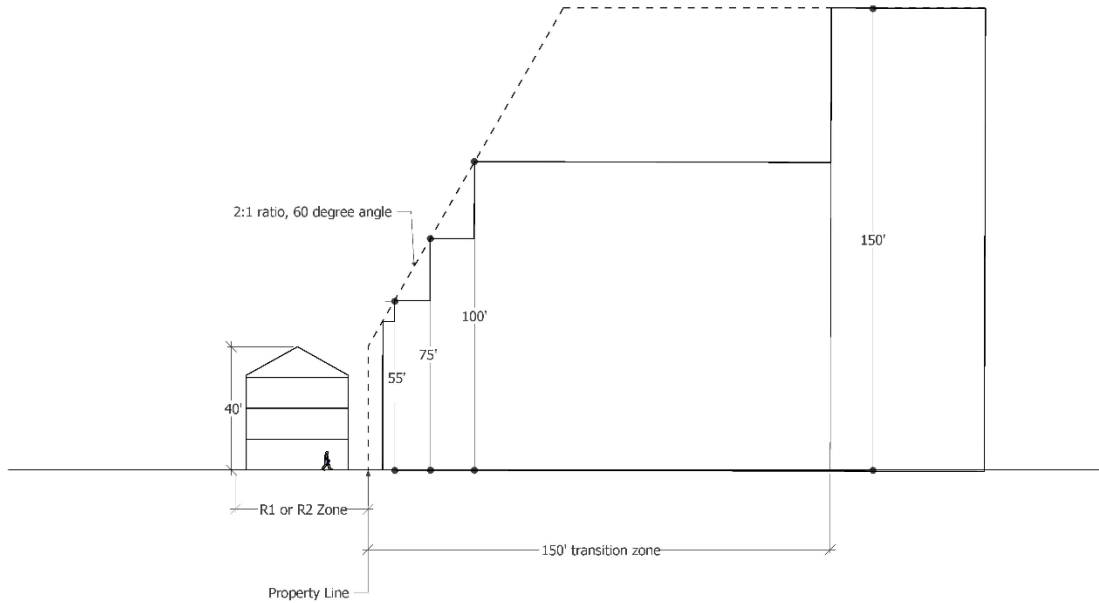

Figure 17C.120.220: Height Transition

4. Projections Allowed.

Chimneys, flag poles, satellite receiving dishes, and other similar items with a width, depth or diameter of five feet or less may rise ten feet above the height limit, or five feet above the highest point of the roof, whichever is greater. If they are greater than five feet in width, depth or diameter, they are subject to the height limit.

5. Rooftop Mechanical Equipment.

All rooftop mechanical equipment must be set back at least fifteen feet from all roof edges that are parallel to street lot lines. Elevator mechanical equipment may extend up to sixteen feet above the height limit. Other rooftop mechanical equipment which cumulatively covers no more than ten percent of the roof area may extend ten feet above the height limit.

6. Radio and television antennas, utility power poles, and public safety facilities are exempt from the height limit except as provided in chapter 17C.355A SMC, Wireless Communication Facilities.

C. Special Height Districts

Special height districts are established to control structure heights under particular circumstances such as preservation of public view or airport approaches. See [chapter 17C.170 SMC](#), Special Height Overlay Districts.

17C.122 CENTER & CORRIDOR TEXT AMENDMENTS

The proposed Spokane Municipal Code Text Amendments related to Center and Corridor zoning are citywide and not limited to the South Logan Project Area. The citywide changes implement recommendations from the [South Logan TOD Plan](#), with citywide implementation ensuring consistency. The South Logan TOD Plan anticipated [Section 17C.400.040 Pilot Center and Corridors Development Standards](#) would be made permanent. As an interim ordinance, the purpose is to identify which regulations should be kept and which should be adjusted or removed. The proposed regulations make permanent, with adjustments informed by the pilot period and through analysis from the [Centers and Corridors Study](#), the interim citywide regulations. The proposal includes adjusting height standards, not permitting drive-thrus in the CC1 zone or along Pedestrian Street designations, implementing height bonuses instead of FAR bonuses, modifying parking requirements, as well as consolidation and reorganization for improved useability.

Text with (~~strikethrough~~) is proposed to be repealed/modified with underlined text representing proposed text. Text without a strikethrough or underline is existing and not proposed to be modified.

The proposed Center & Corridor text amendments also include a number of new sections, largely due to reorganization. These sections do not include strikethrough or underlined text. These new sections and proposed changes are noted in the text amendment tracking sheet.

Section 1. That SMC Section 17C.122.070 Center and Corridor Zone Allowed Uses is amended to read as follows:

Section 17C.122.070 Center and Corridor Zone Allowed Uses

The uses allowed in the (~~center~~) Center and (~~corridor~~) Corridor zones are shown in Table 17C.122.070-1.

TABLE 17C.122.070-1 CENTER AND CORRIDOR ZONE ALLOWED USES			
Use is: P – Permitted N – Not Permitted L – Allowed, but special limitations CU – Conditional use review required	CC Zone Type		
	Core Zones		Transition Zone
	CC1	CC2	CC4
Residential (*)	P	P	P
Hotels, including Bed and Breakfast Inns	P	P	N
Commercial, Financial, Retail, Personal Services (for neighborhood centers (NC) – See Note 1 below)	P [1]	P [1]	L [4]

Eating and Drinking Establishments (((for neighborhood centers (NC) — See Note 2 below)))	P [2]	P [2]	N
Restaurants without Cocktail Lounges	P	P	L [4]
Professional and Medical Offices	P	P	L [4]
Entertainment, Museum and Cultural	P	P	N
Government, Public Service or Utility Structures, Social Services and Education	P	P	P
Religious Institutions	P	P	P
Parks and Open Space	P	P	P
Structured Parking*	P	P	P
Public Parking Lot	P	P	N
Limited Industrial (if entirely within a building) (((for neighborhood centers (NC) — See Note 3 below)))	P [3]	P [3]	N
Heavy Industrial	N	N	N
Drive-through Businesses ((on Pedestrian Streets))	N	((N)) P [5]	((N)) P [5]
Motor Vehicles Sales, Rental, Repair or Washing	N	P	N
Automotive Parts and Tires (with exterior storage or display)	N	P	N
Gasoline Sales (serving more than six vehicles)	N	P	N
Gasoline Sale (serving six vehicles or less)	P	P	P
Self-storage or Warehouse	N	P	N
Adult Business (subject to chapter 17C.305 SMC special provisions)	N	N	N
Winery and Microbreweries	P	P	N
Mobile Food Vending	P (([5])) [6]	P (([5])) [6]	P (([5])) [6]

~~((* Uses especially encouraged through greater FAR and bonuses.))~~

Notes:

[1] Retail uses having more than forty thousand ~~((gsf))~~ gross floor area are not permitted in neighborhood centers designated by the comprehensive plan.

[2] Eating and drinking establishments larger than five thousand ~~((gsf))~~ gross floor area are not permitted in neighborhood centers designated by the comprehensive plan.

[3] Limited industrial uses having more than twenty thousand ~~((gsf))~~ gross floor area are not permitted in neighborhood centers designated by the comprehensive plan.

[4] Residential uses are required to be mixed on the same parcel as proposed office and retail uses. Nonresidential uses are limited to three thousand square feet per parcel. In neighborhood centers, nonresidential uses are only allowed on parcels with frontage on an arterial street. Nonresidential uses in the CC4 zone are not allowed within sixty feet of a single-family and two-family residential zone or further than three hundred feet (neighborhood center only) from a CC core comprehensive plan designation.

~~[5] Drive-through businesses are not permitted along designated Pedestrian Streets.~~

~~((5))~~ **6** All mobile food vendors shall have a valid mobile food vending license issued pursuant to [SMC 10.51.010](#).

Section 2. That SMC Section 17C.122.080 Floor Area Ratio (FAR) is repealed.

Section 3. That SMC Section 17C.122.090 is amended to read as follows:

Section 17C.122.090 Public Amenities Allowing Bonus ((FAR)) Height

~~((A. — Minor Amenities.~~

~~Each public amenity from the following list may allow an increase of two-tenths FAR from the basic allowable FAR to the maximum FAR.~~

~~1. — Additional Streetscape Features.~~

~~Seating, trees, pedestrian scaled lighting and special paving in addition to any that are required by the design standards and guidelines.~~

~~2. — Canopy Over the Public Sidewalk.~~

~~A virtually continuous canopy structure. A canopy is a permanent architectural element projecting out from a building facade over a sidewalk or walkway. A canopy shall be at least five feet in horizontal width and be no less than eight feet and no more than twelve feet above grade.~~

~~3. — Alley Enhancements.~~

~~Decorative paving, pedestrian scaled lighting, special paving and rear entrances intended to encourage pedestrian use of the alley.~~

~~4. — Preferred Materials on Building.~~

~~Use of brick and stone on the building facades that face streets.~~

~~5. — An amenity specifically identified and described in an adopted neighborhood plan.~~

~~6. — Building to the Street.~~

~~Buildings complying with the “Buildings Along the Street” design guidelines (page 4 of the center and corridor design guidelines) so that at least fifteen percent of the frontage of the site consists of building facades.~~

~~B. — Major Amenities.~~

~~Each public amenity from the following list may allow an increase of five-tenths FAR from the basic allowable FAR to the maximum FAR.~~

~~1. Exterior Public Space(s).~~

~~A plaza or courtyard, with a minimum area of four hundred square feet or two percent of the total interior floor space of the development, whichever~~

~~is greater. A plaza or a courtyard is a level space accessible to the public, at least ten feet in width, with a building façade on at least one side. The elevation of the courtyard or plaza shall be within thirty inches of the grade of the sidewalk providing access to it. For courtyards, at least sixty percent of the green shall be planted with trees, ground cover and other vegetation. For plazas, at least fifteen percent, but no more than sixty percent of the space shall be planted with trees, ground cover and other vegetation. Courtyards and plazas shall also include seating, pedestrian-scale lighting, decorative paving and other pedestrian furnishings. The use of artists to create fixtures and furnishings is strongly encouraged.~~

~~2. Public Art.~~

~~Public art includes sculptures, murals, inlays, mosaics and other two-dimensional or three-dimensional works, as well as elements integrated into the design of a project (e.g. fountain) that are designed and crafted by one or more artists. Such artists must be listed on a registry of either the Washington state arts commission or the Spokane arts commission. To receive the FAR bonus, public art must be documented at a value that is at least one percent of the value of construction.~~

~~3. Through-block pedestrian connection providing a continuous walkway accessible to the public, at least ten feet in width, paved with decorative paving and lighted for nighttime use. It may be covered or open to the sky.~~

~~4. Residential Units.~~

~~Comprising at least twenty five percent of the total floor area.~~

~~5. Structured parking.~~

~~6. If all of the standards and guidelines for Type 1 centers and pedestrian streets are incorporated into a project that is within a Type 2 center.~~

~~C. "Super Bonuses."~~

~~Any development that receives super bonuses shall also provide at least two of the major or minor amenities listed above. In return for providing either of the following, the maximum FAR's may be increased by fifty percent.~~

~~1. Underground Parking.~~

~~All of the parking is provided within a structure that is entirely below grade.~~

~~2. Affordable Housing.~~

~~At least twenty percent of the units are set aside for households making less than eighty percent of the median income for the City as defined by HUD.))~~

A. Development that meets the following conditions may be allowed an additional fifteen feet of height to the maximum height standards in Section 17C.122.200 Development Standards Table.

1. Underground Parking.

a. All off-street parking provided on the site meets one of the following conditions:

i. Parking areas are entirely below the grade of any adjacent streets; or

ii. Surface parking or structured parking at ground level is located entirely behind buildings relative to all adjacent streets; or

iii. Structured parking visible from the street is above ground level with non-parking uses lining the street.

2. Affordable Housing.

a. At least twenty percent of the residential units are set aside for households making less than eighty percent of the Spokane County Area Median Income as defined by the United States Department of Housing and Urban Development.

3. Public Art.

a. May include sculptures, murals, inlays, mosaics, and other two-dimensional or three-dimensional works, as well as elements integrated into the design of a project (e.g., fountain) that are designed and crafted for the aesthetic improvement of the pedestrian realm.

i. To receive the height bonus, public art must be documented at a value that is at least one percent of the value of construction.

Section 4. That SMC Section 17C.122.100 Maximum Building Height is repealed.

Section 5. That SMC Section 17C.122.110 Setbacks and Required Sidewalk Width is repealed.

Section 6. That there is adopted a new Section 17C.122.200 to Chapter 17C.122 SMC to read as follows:

Section 17C.122.200 Development Standards Table

Development standards that apply within Center and Corridor Zones are provided in Table 17C.122.200-2 Center and Corridor Development Standards

Table 17C.122.200-2 Center and Corridor Development Standards				
HEIGHT STANDARDS				
		CC1	CC2	CC4
Neighborhood Center		55 ft [1][2]	55ft [1][2]	55ft [1][2]
District Center or Corridor		75 ft [1][2]	75 ft [1][2]	55 ft [1][2]
Employment Center		150 ft [2]	150 ft [2]	75 ft [2]
FLOOR AREA RATIO (FAR) STANDARDS				
		CC1	CC2	CC4
Neighborhood Center	Minimum FAR	No Minimum	No Minimum	No Minimum
	Maximum FAR	No Maximum	No Maximum	No Maximum
District Center	Minimum FAR	0.5	0.5	0.5
	Maximum FAR	No Maximum	No Maximum	No Maximum
Employment Center	Minimum FAR	1	1	1
	Maximum FAR	No Maximum	No Maximum	No Maximum
SETBACK STANDARDS				
		CC1	CC2	CC4
Minimum setback from street lot line		0 ft.	0 ft.	0 ft. ((3))
Minimum setback from R1 and R2 zoned lots		10 ft. ((4)) 3	10 ft. ((4)) 3	10 ft. ((4)) 3
Minimum setback from all zones except R1 and R2		0 ft. ((4)) 3	0 ft. ((4)) 3	0 ft. ((4)) 3
LOT DIMENSIONS				
		CC1	CC2	CC4
Minimum front lot line width		10 ft.	10 ft.	10 ft.
<p>[1] An additional fifteen ft of height is permitted provided that at least one condition under Section 17C.122.090 Public Amenities Allowing Additional Height is met.</p> <p>[2] Structures over seventy feet in height must follow the standards in Chapter 17C.250 Tall Building Standards.</p> <p>[3] ((When abutting R1 and R2 zoned lots, the minimum structure setback from street lot line is the same as the abutting residential zoning district for the first 60 ft. from the boundary of the abutting residential zoning district. See SMC 17C.120.230 for additional standards and exceptions. This does not apply when a zone boundary is within the public right-of-way.))</p> <p>((4)) Structure setbacks are measured from the lot line.</p>				

Section 7. That there is adopted a new Section 17C.122.210 to Chapter 17C.122 SMC to read as follows:

Section 17C.122.210 Height

A. Height.

The maximum height standards for all structures are stated in Table 17C.122.200-2. The building height shall be measured using the following method (see Figure 17C.122.210-A):

1. Building height is the vertical distance from the average grade to the highest point of the roof or structure.
2. Underground portions of the structure are not included in height calculations. The height of the structure shall be calculated from the point at which the sides meet the surface of the ground.
3. "Average grade" means the average of the ground level adjoining the building at all exterior walls. Where the ground level slopes away from the exterior walls, the reference point shall be established by the lowest points within the area between the building and the lot line or where the lot line is more than 6 feet from the building, use the reference point between the structure and a point 6 feet from the building.
4. Measurements shall be taken at the existing grade or finished grade, whichever is lower.
5. Depressions such as window wells, stairwells for exits required by other codes, "barrier-free" ramps on grade, and vehicle access driveways into garages shall be disregarded in determining structure height when in combination they comprise less than fifty percent of the facade on which they are located. In such cases, the grade for height measurement purposes shall be a line between the grades on either side of the depression.
6. Public amenities allowing additional height can be found in Section 17C.122.090 Public Amenities Allowing Bonus Height.
7. For buildings over 70 feet tall, Chapter 17C.250 Tall Building Standards apply.

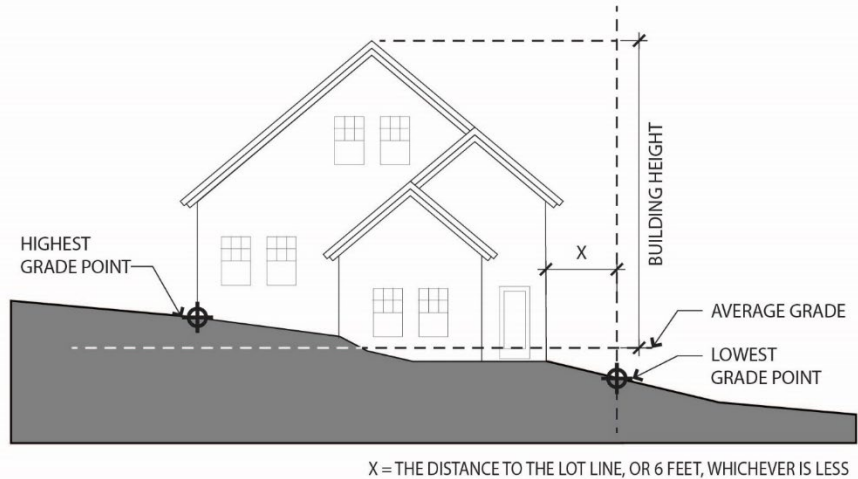

Figure 17C.122.210-A

Section 8. That there is adopted a new Section 17C.122.220 to Chapter 17C.122 SMC to read as follows:

Section 17C.122.220 Height Transition

A. Purpose.

The following exception to the maximum building height standards is to provide a gradual transition and enhance the compatibility between the more intensive center zones and adjacent low and moderate residential zones.

B. Applicability.

For all development adjacent to R1 or R2 zoned properties the maximum building height is as follows:

1. Starting at a height of 40 ft. at R1 and R2 property boundaries, additional building height may be added at a ratio of 2 to 1 (two feet of additional building height for every one foot of additional horizontal distance from the closest R1 or R2 zoned property line).
2. The building height transition requirement ends 150 ft. from the R1 or R2 zoned property line. Beyond the transition, the maximum building height of the zone applies.

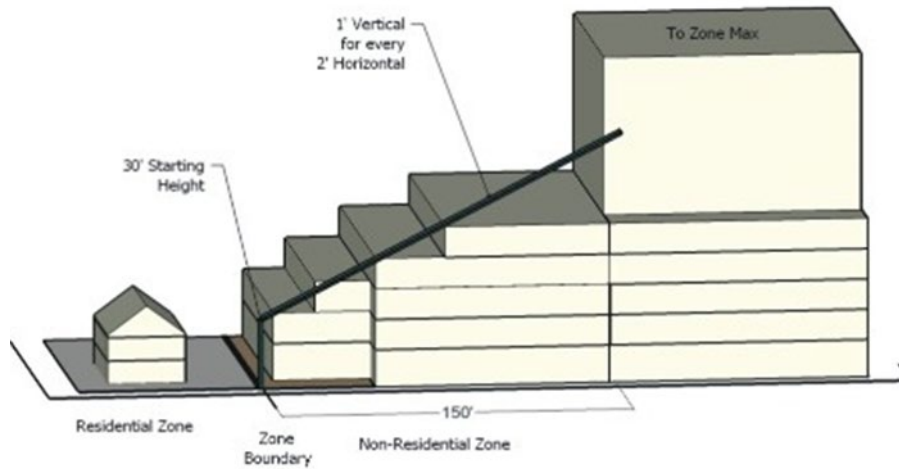

[NOTE: Delete graphic above]

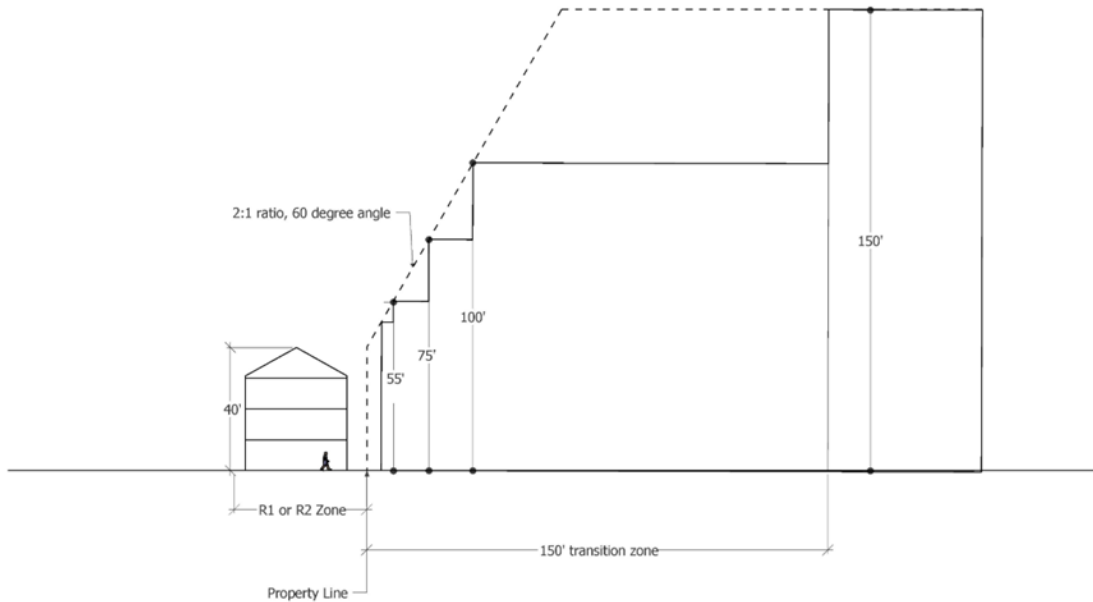

Figure 17C.122.220-A: Height Transition

Section 9. That there is adopted a new Section 17C.122.230 to Chapter 17C.122 SMC to read as follows:

Section 17C.122.230 Floor Area Ratio

- A. Floor Area Ratio (FAR).

FAR standards are stated in Table 17C.122.200-2. FAR is the measurement of the building's gross floor area in relation to the size of the lot. A structure that has the same gross floor area as the area of the lot is considered to have a FAR of 1, if the structure has half the gross floor area as the area of the lot the FAR is 0.5. In addition to other dimensional standards FAR is used to ensure the intensity of the structure is appropriate to the zoning.

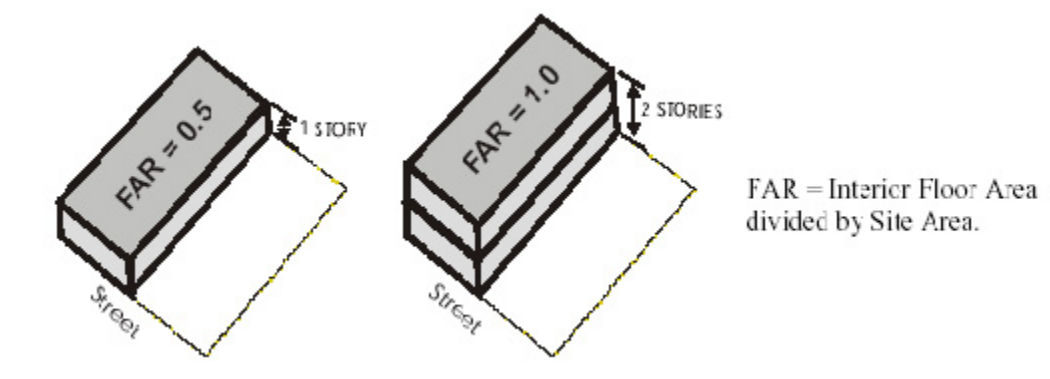

Section 10. That there is adopted a new Section 17C.122.240 to Chapter 17C.122 of the Spokane Municipal Code that SMC to read as follows:

Section 17C.122.240 Setbacks

A. Setbacks.

Setback Standards are stated in Table 17C.122.200-2. Setbacks in Centers and Corridors ensure that there is adequate space between the structure's facade and the street allowing for ample space for the pedestrian realm.

1. The minimum setback from street lot lines is zero feet and buildings shall be no closer than twelve feet from the back of the curb except as provided in 17C.122.240(A)(2).
2. This width may be reduced, by approval of the Planning Director, if the existing sidewalk is less than twelve feet wide between the back of the curb and the existing building setback line of the adjacent building(s). In no case shall the setback be reduced below nine feet from the back of the curb.

Section 11. That there is adopted a new Section 17C.122.250 to Chapter 17C.122 SMC to that read as follows:

Section 17C.122.250 Sidewalks

A. Sidewalks.

1. Sidewalks shall be at least twelve feet wide and consist of a clear walking path at least seven feet wide (in addition to a planting zone for street trees per SMC 17C.200.050) except as provided in 17C.122.240(A)(2).

Section 12. That Chapter 17C.122T entitled “Center and Corridor Zone Development Tables” is repealed.

Section 13. That SMC Section 17C.230.120 is amended to read as follows:

Section 17C.230.120 Maximum Required Parking Spaces

A. Purpose.

Limiting the number of spaces allowed promotes efficient use of land, enhances urban form, encourages use of alternative modes of transportation, provides for better pedestrian movement, and protects air and water quality. The maximum ratios in this section vary with the use the parking it is accessory to. These maximums will accommodate most auto trips to a site based on typical peak parking demand for each use.

B. Maximum Number of Parking Spaces Allowed.

Standards in a plan district or overlay zone may supersede the standards in this subsection.

1. Surface Parking.

The maximum number of parking spaces allowed is stated in Table 17C.230.120-1 and Table 17C.230.130-1, except as specified in subsection (B)(2) of this section.

2. Structure Parking.

Parking provided within a building or parking structure is not counted when calculating the maximum parking allowed.

TABLE 17C.230.120-1 PARKING SPACES BY ZONE [1] (Refer to Table 17C.230.130-1 for Parking Spaces Standards by Use)		
ZONE	SPECIFIC USES	REQUIREMENT
RA, R1, R2, RMF, RHD	All Land Uses	Minimum and maximum standards are shown in Table 17C.230.130-1 .

O, OR, NR, NMU, CB, GC, Industrial		
((CC1, CC2, CC3 [2])	Nonresidential	Minimum ratio is 1 stall per 1,000 gross square feet of floor area. Maximum ratio is 4 stalls per 1,000 gross square feet of floor area.
	Residential	Minimum ratio is 1 stall per 1,000 gross square feet of floor area or a minimum of 1 stall per dwelling unit plus one per bedroom after 3 bedrooms. Maximum ratio is the same as for nonresidential uses.
CC4 [2]	Nonresidential	Minimum ratio is 2 stalls per 1,000 gross square feet of floor area. Maximum ratio is 4 stalls per 1,000 gross square feet of floor area.
	Residential	Minimum ratio is 1 stall per 1,000 gross square feet of floor area or a minimum of 1 stall per dwelling unit, whichever is less. Maximum ratio is the same as for nonresidential uses.))
CC1, CC2, CC3, CC4 [2]	<u>Nonresidential</u>	<u>There is no minimum parking requirement. Maximum ratio is 4 stalls per 1,000 gross square feet of floor area.</u>
	<u>Residential</u>	<u>There is no minimum parking requirement. Maximum ratio is 4 stalls per 1,000 gross square feet of floor area.</u>
Downtown [2]	((<u>All Land Uses</u>)) <u>Nonresidential</u>	((See the Downtown Parking Requirement Map 17C.230-M1 to determine if parking is required. - Minimum ratio for areas shown on the map that require parking is 1 stall per 1,000 gross square feet of floor area or a

		<p>minimum of 1 stall per dwelling unit, whichever is less.))</p> <p><u>There is no minimum parking requirement.</u></p> <p>Maximum ratio is 3 stalls per 1,000 gross square feet of floor area.</p>
	<u>Residential</u>	<p><u>There is no minimum parking requirement.</u></p> <p><u>Maximum ratio is 3 stalls per 1,000 gross square feet of floor area.</u></p>
FBC [2]	All Land Uses	See SMC 17C.123.040 , Hamilton Form Based Code for off-street parking requirements.
Overlay	All Land Uses	No off-street parking is required. See the No Off-Street Parking Required Overlay Zone Map 17C.230-M2 and No Off-Street Parking Required Overlay Zone Map 17C.230-M3 .
<p>[1] Standards in a plan district or overlay zone may supersede the standards of this table.</p> <p>[2] See exceptions in SMC 17C.230.130, CC and Downtown Zone Parking Exceptions.</p>		

Section 14. That SMC Section 17C.230.130 is amended to read as follows:

Section 17C.230.130 Parking Exceptions

- A. In (~~center and corridor downtown, and FBC CA1, CA2, and CA3 zones any new building or building addition with a floor area less than three thousand square feet shall have no parking requirement~~), all Center and Corridor zones, all Downtown zones, and all Form-Based Code no parking is required.
- B. In the (~~neighborhood retail~~) Neighborhood Retail zone, any existing building, new building, or building addition, having a floor area less than three thousand square feet shall have no parking requirement. In addition, if a building has a floor area of five thousand square feet or less, the parking requirement will be determined after deducting the three thousand square foot exemption from the building’s floor area. For example, the parking requirement for a four thousand square foot building would be based on one thousand square feet of floor area –

i.e., a four thousand square foot building size minus the three thousand square foot exemption.

- C. The Planning Director may approve ratios that are higher than the maximum or lower than the minimum if sufficient factual data is provided to indicate that a different amount is appropriate. The applicant assumes the burden of proof. Approval of parking above the maximum shall be conditioned upon increasing the amount of required landscaping by thirty percent. Approval of parking below the minimum shall be conditioned upon the project contributing towards a pedestrian and transit supportive environment both next to the immediate site and in the surrounding area. When determining if a different amount of parking is appropriate, the Director shall consider the proximity of the site to frequent transit service, the intensity of the zoning designation of the site and surrounding sites, and the form of the proposed use.
- D. If property owners and businesses establish a parking management area program with shared parking agreements, the Planning Director may reduce or waive parking requirements.
- E. Existing legal nonconforming buildings that do not have adequate parking to meet the standards of this section are not required to provide off-street parking when remodeling which increases the amount of required parking occurs within the existing structure.
- F. Attached Housing.
The following exceptions apply only to attached housing (defined in SMC 17A.020.010) in the RMF and RHD zones. Distances are measured in a straight line between the zone/overlay boundary to the lot line of the site containing the development.
 - 1. On a lot at least partially within one thousand three hundred twenty feet of CC, CA, or DT zone or CC3 zoning overlay, the minimum number of off-street vehicle parking spaces required is fifty percent less than the minimum required for Residential Household Living in Table 17C.230.130-1.
 - 2. On a lot farther than one thousand three hundred twenty feet of a CC, CA, or DT zone or CC3 zoning overlay, the minimum number of off-street vehicle parking spaces required is thirty percent less than the minimum required for Residential Household Living in Table 17C.230.130-1.
- G. Parking is not required for residential development on sites located within one-half mile of a transit stop.

TABLE 17C.230.130-1 PARKING SPACES BY USE [1]
--

(Refer to Table 17C.230.120-1 for Parking Space Standards by Zone)
CU = Conditional Use

RESIDENTIAL CATEGORIES

USE CATEGORIES	SPECIFIC USES	MINIMUM PARKING	MAXIMUM PARKING
Group Living		1 per 4 residents	None
<u>Residential Household Living within one-half mile of a transit stop</u>		<u>None</u>	<u>None</u>
Residential Household Living <u>outside of one-half mile of a transit stop</u> [2] [3]		<p>((1 per unit plus 1 per bedroom after 3 bedrooms [3]; Accessory Dwelling Unit (ADU) — see Note [4]; Single Resident Occupancy (SRO) are exempt))</p> <p><u>On lots smaller than 6,000 square feet, only one parking space per unit is required regardless of bedroom count.</u></p> <p><u>On lots 6,000 square feet or larger, each unit with 3 or fewer bedrooms shall provide one parking space per unit and each unit with 4 or more bedrooms shall provide a minimum of two parking spaces per unit.</u></p>	None

COMMERCIAL CATEGORIES

USE CATEGORIES	SPECIFIC USES	MINIMUM PARKING	MAXIMUM PARKING
-----------------------	----------------------	------------------------	------------------------

Adult Business		1 per 500 sq. ft. of floor area	1 per 200 sq. ft. of floor area
Commercial Outdoor Recreation		20 per acre of site	30 per acre of site
Commercial Parking		Not applicable	None
Drive-through Facility		Not applicable	None
Major Event Entertainment		1 per 8 seats or per CU review	1 per 5 seats or per CU review
Office	General Office	1 per 500 sq. ft. of floor area	1 per 200 sq. ft. of floor area
	Medical/Dental Office	1 per 500 sq. ft. of floor area	1 per 200 sq. ft. of floor area
Quick Vehicle Servicing		1 per 500 sq. ft. of floor area	1 per 200 sq. ft. of floor area
Retail Sales and Service	Retail, Personal Service, Repair-oriented	1 per 330 sq. ft. of floor area	1 per 200 sq. ft. of floor area
	Restaurants and Bars	1 per 250 sq. ft. of floor area	1 per 60 sq. ft. of floor area
	Health Clubs, Gyms, Lodges, Meeting Rooms and similar continuous entertainment, such as Arcades and Bowling Alleys	1 per 330 sq. ft. of floor area	1 per 180 sq. ft. of floor area
	Temporary Lodging	1 per rentable room; for associated uses	1.5 per rentable room; for associated uses such as

		such as Restaurants, see above	Restaurants, see above
	Theaters	1 per 4 seats or 1 per 6 feet of bench area	1 per 2.7 seats or 1 per 4 feet of bench area
	Retail sales and services of large items, such as appliances, furniture and equipment	1 per 1,000 sq. ft. of floor area	1 per 200 sq. ft. of floor area
Mini-storage Facilities		Same as Warehouse and Freight Movement	Same as Warehouse and Freight Movement
Vehicle Repair		1 per 750 sq. ft. of floor area	1 per 200 sq. ft. of floor area

INDUSTRIAL CATEGORIES

USE CATEGORIES	SPECIFIC USES	MINIMUM PARKING	MAXIMUM PARKING
Industrial Services, Railroad Yards, Wholesale Sales		1 per 1,000 sq. ft. of floor area	1 per 200 sq. ft. of floor area
Manufacturing and Production		1 per 1,000 sq. ft. of floor area	1 per 200 sq. ft. of floor area
Warehouse and Freight Movement		1 per 1,000 sq. ft. of floor area for the first 3,000 sq. ft of floor area and then 1 per 3,500 sq. ft. of floor area thereafter	1 per 200 sq. ft. of floor area
Waste-related		Per CU review	Per CU review

INSTITUTIONAL CATEGORIES

USE CATEGORIES	SPECIFIC USES	MINIMUM PARKING	MAXIMUM PARKING
-----------------------	----------------------	------------------------	------------------------

Basic Utilities		None	None
Colleges		1 per 600 sq. ft. of floor area exclusive of dormitories, plus 1 per 4 dorm rooms	1 per 200 sq. ft. of floor area exclusive of dormitories, plus 1 per 2.6 dorm room
Community Service		1 per 500 sq. ft. of floor area	1 per 200 sq. ft. of floor area
Daycare		1 per 500 sq. ft. of floor area	1 per 200 sq. ft. of floor area
Medical Centers		1 per 500 sq. ft. of floor area	1 per 200 sq. ft. of floor area
Parks and Open Areas		Per CU review for active areas	Per CU review for active areas
Religious Institutions		1 per 100 sq. ft. of main assembly area or per CU review	1 per 60 sq. ft. of main assembly area
Schools	Grade, Elementary, Junior High	1 per classroom	2.5 per classroom
	High School	7 per classroom	10.5 per classroom
OTHER CATEGORIES			
USE CATEGORIES	SPECIFIC USES	MINIMUM PARKING	MAXIMUM PARKING
Agriculture		None or per CU review	None or per CU review
Aviation and Surface Passenger Terminals		Per CU review	Per CU review
Detention Facilities		Per CU review	Per CU review
Essential Public Facilities		Per CU review	Per CU review
Wireless Communication Facilities		None or per CU review	None or per CU review

Rail Lines and Utility Corridors		None	None
<p>[1] The Planning Director may approve different amounts of parking spaces under the exceptions listed in SMC 17C.230.130.</p> <p>(([2] Parking is not required for residential development on sites located within one-half mile of a transit stop.))</p> <p><u>[2] For purposes of calculating parking, an Accessory Dwelling Unit shall count as a full dwelling unit. Studio and one-bedroom ADUs require no additional parking.</u></p> <p>(([3] For middle housing developed in the R1 and R2 zones, the following standards apply:</p> <ul style="list-style-type: none"> • On lots smaller than 6,000 square feet, only one parking space per unit is required regardless of bedroom count. • On lots 6,000 square feet or larger, each unit with 4 or more bedrooms must provide a minimum of two parking spaces.)) <p><u>[3] Single Room Occupancy housing is exempted from parking requirements.</u></p> <p>(([4] Parking requirements for ADUs are provided in SMC 17C.300.130(A)(4.))</p>			

Section 15. That SMC Section 17C.300.130 is amended to read as follows:

Section 17C.300.130 Development Standards

A. Development Standards – Requirements for All Accessory Dwelling Units.

All accessory dwelling units must meet the following:

1. Creation.

An accessory dwelling unit may only be created through the following methods:

- a. Converting existing living area, attic, basement or garage.
- b. Adding floor area.
- c. Constructing a detached accessory dwelling unit on a site with an existing residential use.
- d. Constructing a residential use with an internal or detached accessory dwelling unit.
- e. In the R1, R2, RMF, or RHD zone, constructing an attached or detached accessory dwelling unit on a site with any existing or new principal structure (including non-residential uses or structures). Any structure shall comply with all applicable building, fire, and engineering standards.

2. Number of Residents.

The total number of individuals that reside in all units on the site may not exceed any lawful limits on occupant load per square foot or generally applicable health and safety provisions as established by applicable building or fire code, as provided in RCW 35.21.682.

3. Location of Entrances for Internal ADUs.

Only one entrance may be located on the facade of the structure facing the street, unless the principal structure contained additional entrances before the accessory dwelling unit was created. An exception to this regulation is entrances that do not have access from the ground such as entrances from balconies or decks.

4. Parking.

a. Studio and one-bedroom ADUs require no additional parking. ~~((One additional off-street parking space is required for the accessory dwelling unit with more than one bedroom, plus one per bedroom after two bedrooms. Existing required parking for the principal structure must be maintained.))~~

~~((b. As an exception to subsection (a), no additional off-street parking space is required for the ADU within one-quarter mile of stops for a bus or other transit mode providing actual fixed route service at intervals of no less frequently than fifteen minutes for at least five hours during the peak hours of operation on weekdays, defined as a major transit stop under RCW 36.70A.696.))~~

b. Parking for Accessory Dwelling Units is provided in Table 17C.230.130-1 under Residential Household Living. For purposes of determining required parking, an Accessory Dwelling Unit is a full dwelling unit.

B. Additional Development Standards for Detached ADUs.

1. Setbacks.

Except for conversion of existing accessory structures, the accessory dwelling unit must be:

a. as specified for setbacks in [Table 17C.111.205-2](#) for accessory structures and

2. Height.

The maximum height allowed for a detached accessory dwelling unit is provided in [Table 17C.111.205-2](#).

3. Bulk Limitation.

The building coverage for the detached accessory dwelling unit may not be larger than the building coverage of the principal structure.

- a. On lots five thousand five hundred square feet or larger, the combined building coverage of all detached accessory structures may not exceed fifteen percent of the total area of the site.
- b. On lots smaller than five thousand five hundred square feet, the combined building coverage of all detached accessory structures may not exceed twenty percent of the total area of the site.

4. Conversion of Existing Detached Accessory Structures.

- a. Conversion of an existing detached accessory structure that is in a front building setback required by [Table 17C.111.205-2](#) is not allowed. Conversion of an existing detached accessory structure that is in a rear or side building setback is allowed as provided by [SMC 17C.111.235](#), Setbacks, and [SMC 17C.111.240](#), Accessory Structures.
- b. If the accessory dwelling unit is proposed for an existing detached accessory structure that meets any of the standards of subsections (B)(2) and (3) of this section, alterations that will move the structure out of conformance with the standards that are met are not allowed.
- c. If the accessory dwelling unit is proposed as a conversion of an existing detached accessory structure or a portion of the building, and any floor area is added to the existing detached accessory structure to accommodate an ADU, then the entire structure must meet the underlying zoning development standards.

C. Utilities and Addressing.

The ADU must utilize those municipal utilities and address established for the principal dwelling unit.

D. Code Compliance.

The ADU must meet all technical code standards of this title including building, electrical, fire, and plumbing code requirements and permits.

17C.111.205/17C.111.420 RMF & RHD TEXT AMENDMENTS

The proposed Spokane Municipal Code Text Amendments related to building height are citywide and not limited to the South Logan Project Area. The citywide changes implement recommendations from the [South Logan TOD Plan](#), with citywide implementation ensuring consistency of height and multifamily open space requirements throughout Spokane. The proposal includes increased default maximum heights to the RMF (Residential Multifamily) and RHD (Residential High Density) zones as well as adjustments to open space requirements to increase feasibility of higher intensity infill development. Proposed open space requirements include allowing proximity to a public park to count towards open space requirements, which is proposed to apply to all residential zones, and having different minimum open space requirements depending on unit size and infill site status in RMF and RHD.

Text with ((~~strikethrough~~)) is proposed to be repealed/modified with underlined text representing proposed text. Text without a strikethrough or underline is existing and not proposed to be modified.

Section 1. That SMC Section 17C.111.205 be amended to read as follows:

Section 17C.111.205 Development Standards Tables

Development standards that apply within the residential zones are provided in Tables 17C.111.205-1 through 17C.111.205-3.

TABLE 17C.111.205-1					
LOT DEVELOPMENT STANDARDS [1]					
	RA	R1	R2	RMF	RHD
DENSITY STANDARDS					
Maximum density on sites 2 acres or less [2][3]	No maximum	No maximum	No maximum	No maximum	No maximum
Maximum density on sites larger than 2 acres [2]	10 units/acre	10 units/acre	20 units/acre	No maximum	No maximum
Minimum density [2]	4 units/acre	4 units/acre	10 units/acre	15 units/acre	15 units/acre
LOT DIMENSIONS FOR SUBDIVISIONS AND SHORT SUBDIVISIONS					
Minimum lot area	7,200 sq. ft.	1,200 sq. ft.	1,200 sq. ft.	1,200 sq. ft.	1,200 sq. ft.
Minimum lot width with no driveway approach [4]	40 ft.	15 ft.	15 ft.	15 ft.	15 ft.
Minimum lot width with driveway approach [4]	40 ft.	36 ft.	36 ft.	25 ft.	25 ft.

Minimum lot width within Airfield Overlay Zone	40 ft.	40 ft.	36 ft.	25 ft.	25 ft.
Minimum lot depth	80 ft.	80 ft.	40 ft.	N/A	N/A
Minimum lot frontage	40 ft.	Same as minimum lot width	Same as minimum lot width	Same as minimum lot width	Same as minimum lot width
MINIMUM LOT DIMENSIONS FOR UNIT LOT SUBDIVISIONS					
Minimum parent lot area	No minimum	No minimum	No minimum	No minimum	No minimum
Maximum parent lot area	2 acres	2 acres	2 acres	2 acres	2 acres
Minimum child lot area	No minimum	No minimum	No minimum	No minimum	No minimum
Minimum child lot depth	No minimum	No minimum	No minimum	No minimum	No minimum
LOT COVERAGE					
Maximum total building coverage [5][6][7]	50%	65%	80%	100%	100%
Maximum lot impervious coverage without engineer's stormwater drainage plan - not in ADC [5][8]	50%	60%	60%	N/A	N/A
Maximum lot impervious coverage without engineer's stormwater drainage plan - inside ADC [5][8]	40%	40%	40%	N/A	N/A
Notes:					
[1] Plan district, overlay zone, or other development standards contained in Title 17C SMC may supersede these standards.					
[2] See SMC 17C.111.210 for applicability of minimum and maximum density standards in the residential zones.					
[3] Development within Airfield Overlay Zones is further regulated as described in SMC 17C.180.090, Limited Use Standards.					
[4] Lots with vehicle access only from an alley are not considered to have a "driveway approach" for the purposes of this standard.					
[5] Lot and building coverage calculation includes all primary and accessory structures.					
[6] Building coverage for attached housing is calculated based on the overall development site, rather than individual lots.					

[7] Developments meeting certain criteria relating to transit, Centers & Corridors, or housing affordability are given a bonus for building coverage. See SMC 17C.111.225 for detailed eligibility criteria.

[8] Projects may exceed impervious coverage requirements by including an engineer's drainage plan in submittals, subject to review by the City Engineer as described in SMC 17D.060.135. "ADC" means Area of Drainage Concern.

TABLE 17C.111.205-2					
BUILDING AND SITING STANDARDS [1]					
	RA	R1	R2	RMF	RHD
PRIMARY BUILDINGS					
Floor area ratio	N/A	N/A	N/A	N/A	N/A
Maximum building footprint per primary building - lot area 7,000 sq. ft. or less	N/A	2,450 sq. ft.	2,450 sq. ft.	N/A	N/A
Maximum building footprint per primary building - lot area more than 7,000 sq. ft.	N/A	35%	35%	N/A	N/A
Maximum building height [2]	35 ft.	40 ft.	40 ft.	((40)) <u>55</u> ft.	((40)) <u>75</u> ft.
Minimum Setbacks					
Front	15 ft.	10 ft.	10 ft.	10 ft.	10 ft.
Interior side lot line - lot width 40 ft or less [3]	3 ft.	3 ft.	3 ft.	3 ft.	3 ft.
Interior side lot line - lot width more than 40 ft [4] [5]	5 ft.	5 ft.	5 ft.	5 ft.	5 ft.
Street side lot line – all lot widths	5 ft.	5 ft.	5 ft.	5 ft.	5 ft.
Attached garage or carport entrance from street	20 ft.	20 ft.	20 ft.	20 ft.	20 ft.
Rear	25 ft.	15 ft.	15 ft.	10 ft.	10 ft.
ACCESSORY DWELLING UNITS					
Maximum building footprint for accessory dwelling unit - lot area 5,500 sq. ft. or less	1,100 sq. ft.	1,100 sq. ft.	1,100 sq. ft.	1,100 sq. ft.	1,100 sq. ft.
Maximum building footprint for accessory dwelling unit - lots larger than 5,500 sq. ft.	15%	15%	15%	15%	15%
Maximum building height	25 ft.	25 ft.	25 ft.	25 ft.	25 ft.

Minimum side lot line setbacks [5] [6]	Same as Primary Structure				
Minimum rear setback with alley [4] [5] [6]	0 ft.	0 ft.	0 ft.	0 ft.	0 ft.
Minimum rear setback no alley	5 ft.	5 ft.	5 ft.	5 ft.	5 ft.
OTHER ACCESSORY STRUCTURES					
Maximum lot coverage for accessory structures – lots 5,500 sq. ft. or less	20%	20%	20%	See Primary Structure	See Primary Structure
Maximum lot coverage for accessory structures – lots larger than 5,500 sq. ft.	20%	15%	15%	See Primary Structure	See Primary Structure
Maximum building height	30 ft.	20 ft.	20 ft.	35 ft.	35 ft.
Minimum side lot line setbacks [4] [5] [6]	Same as Primary Structure				
Minimum rear setback with alley	0 ft.	0 ft.	0 ft.	0 ft.	0 ft.
Minimum rear setback no alley	5 ft.	5 ft.	5 ft.	5 ft.	5 ft.
OPEN SPACE [7]					
Minimum ((outdoor area)) <u>open space</u> per unit (([7])) [8]	250 sq. ft.	250 sq. ft.	250 sq. ft.	((200 sq. ft.)) <u>Studio: 48 sq. ft. per unit</u> <u>1- bedroom: 75 sq. ft. per unit</u> <u>2+ bedrooms: 150 sq. ft. per unit</u>	<u>Studio: 48 sq. ft. per unit</u> <u>1-bedroom: 75 sq. ft. per unit</u> <u>2+ bedrooms: 100 sq. ft. per unit</u> <u>Sites 20,000 sq. ft. or less: 36 sq. ft. per unit</u>

Minimum common ((outdoor area)) <u>open space</u> per unit as a substitute for private area - first six units	200 sq. ft.	200 sq. ft.	200 sq. ft.	((150-sq. ft.)) <u>Studio: 48 sq. ft. per unit</u> <u>1- bedroom: 75 sq. ft. per unit</u> <u>2+ bedrooms: 150 sq. ft. per unit</u>	<u>Studio: 48 sq. ft. per unit</u> <u>1-bedroom: 75 sq. ft. per unit</u> <u>2+ bedrooms: 100 sq. ft. per unit</u> <u>Sites 20,000 sq. ft. or less: 36 sq. ft. per unit</u>
Minimum common ((outdoor area)) <u>open space</u> per unit as a substitute for private area - all units after six	150 sq. ft.	150 sq. ft.	150 sq. ft.	((100-sq. ft.)) <u>Studio: 36 sq. ft. per unit</u> <u>1- bedroom: 48 sq. ft. per unit</u> <u>2+ bedrooms: 48 sq. ft. per unit</u>	<u>Studio: ((48)) 36 sq. ft. per unit</u> <u>1-bedroom: 48 sq. ft. per unit</u> <u>2+ bedrooms: 48 sq. ft. per unit</u> <u>Sites 20,000 sq. ft. or less: 25 sq. ft. per unit</u>

Notes:

[1] Plan district, overlay zone, or other development standards contained in Title 17C SMC may supersede these standards.

[2] Base zone height may be modified according to SMC 17C.111.230, Height.

[3] Certain elements such as covered porches may extend into the front setback. See SMC 17C.111.235, Setbacks.

[4] There is an additional angled setback from the interior side lot line. Refer to SMC 17C.111.230(C) and 17C.111.235(E) for more detail.

[5] Setbacks for a detached accessory structure and a covered accessory structure may be reduced to zero feet with a signed waiver from the neighboring property owner as specified in SMC 17C.111.240(C).

[6] Accessory structures may be subject to an additional side setback adjacent to streets as specified in 17C.111.240(C)(5).

[7] Residential units with a continuous pedestrian route as defined in SMC Section 17C.111.420(B) from the property boundary to a public park within 800 feet shall have a minimum of not more than 36 square feet of open space per unit.

~~[[7]]~~ [8] Common ~~((outdoor area))~~ open space may be substituted for private ~~((outdoor area))~~ open space according to SMC 17C.111.310.

TABLE 17C.111.205-3 DEVELOPMENT STANDARDS FOR PROPERTIES QUALIFYING FOR DEVELOPMENT BONUS [1] [2]					
	RA	R1	R2	RMF	RHD
LOT COVERAGE					
Maximum total building coverage	N/A	80%	90%	100%	100%
PRIMARY BUILDINGS					
Floor area ratio	N/A	N/A	N/A	N/A	N/A
Maximum building footprint per primary building - lot area 7,000 sq. ft. or less	N/A	2,450 sq. ft.	2,450 sq. ft.	N/A	N/A
Maximum building footprint per primary building - lot area more than 7,000 sq. ft.	N/A	35%	35%	N/A	N/A
Notes:					
[1] Standards not addressed in this table are consistent with the general standards in Tables 17C.111.205-1 and 17C.111.205-2.					
[2] Criteria to qualify for Development Bonuses is outlined in SMC 17C.111.225.					

Section 2. That SMC Section 17C.111.420 be amended to read as follows:

Section 17C.111.420 ((Outdoor)) Open Spaces

A. Purpose.

To create pedestrian friendly, usable areas through the use of plazas, courtyards, rooftop decks, and other ((outdoors)) open spaces for the enjoyment and health of the residents.

B. ((Outdoor)) Open Spaces Implementation.

1. Minimum Required Space.

((4))a. Each multifamily development shall ((set)) provide ((a minimum of forty-eight square feet of)) the minimum ((outdoor)) open space area for each living unit in the complex, including those units occupied by the owner or building management personnel, as identified in Table 17C.111.205-2. Open spaces may be provided individually, such as by balconies, or combined into a larger common open space. ((Private outdoor spaces can count towards this outdoor common space provision.)) Developments in RMF and RHD may provide both private and common open space to meet the minimum requirement; however, each unit must provide either the full private or common open space to count towards the minimum required space. (R)

b. Residential units with a continuous pedestrian route from the building entrance to a public park within 800 ft are not required to provide more than 36 square feet of open space per unit. For purposes of this requirement, an unsignalized crossing of a minor arterial road or greater shall not be considered a continuous pedestrian route.



Trellis and special landscape defines private courtyard area

[NOTE: Delete graphic above]

2. ~~((Ground Level Units))~~ Private Open Space.

~~((The outdoor area for ground level units is a type of private outdoor space and must be directly accessible from the unit. The area must be surfaced with lawn, pavers, decking or sport court paving which allows the area to be used for recreational purposes. User amenities, such as tables, benches, trees, planter boxes, garden plots, drinking fountains, spas or pools, may be placed in the outdoor area. It may be covered, such as a covered patio, but it may not be fully enclosed. (R)))~~

Private open space area is typically developed for passive recreational use. Examples include balconies, patios, and private rooftop decks.



[NOTE: Delete graphic above]

a. Private open space must be directly accessible from the unit. (R)

b. Private open space must be surfaced with landscaping, pavers, decking, or sport court paving which allows the area to be used for recreational purposes. (R)

c. Private open space may be covered, such as a covered balcony, but may not be fully enclosed. (R)

d. Berms, low walls, fences, hedges and/or landscaping shall be used to define private open spaces such as yards, decks, terraces, and patios from each other and from the street right-of-way. The material or plantings between private open spaces shall be a maximum of four feet in height and visually permeable, such as open rails, ironwork, or trellis treatment to encourage interaction between neighbors. Material or plantings between units and right-of-way shall meet applicable fencing restrictions. (P)

3. ~~((Upper Level Units))~~ Common Open Space.

~~((Upper level units are a type of private outdoor space. For upper level units, the required outdoor area may be provided individually, such as by~~

~~balconies, or combined into a larger area. If combined into a larger area, it must comply with the following requirements. (R))~~

~~Common open space area may be developed for active or passive recreational use. Examples include play areas, plazas, rooftop patios, picnic areas, fitness centers, pools, tennis courts, and open recreational facilities.~~

- a. ~~The total amount of required ((outdoor area for upper level units)) common open space is the cumulative amount of the required area per dwelling unit for ((individual)) common areas, minus any ((upper level)) units that provide individual ((outdoor areas)) open space (if provided). However, a combined required ((outdoor area)) open space must comply with the minimum area ((and dimension requirements for combined outdoor areas)) and meet ADA Standards for Accessible Design.~~
- b. ~~((The combined outdoor area may be developed for active or passive recreational use. Examples include play areas, plazas, rooftop patios, picnic areas, fitness centers, pools, tennis courts, and open recreational facilities. The area)) Common open space must be surfaced with ((lawn)) landscaping, pavers, decking, or sport court paving, which allows the area to be used for recreational purposes. ((User amenities, such as tables, benches, trees, planter boxes, garden plots, drinking fountains, spas or pools may be placed in the outdoor area. It may be covered, such as a covered patio, but it may not be fully enclosed.)) (R).~~
- c. ~~Common open space may be covered, such as a covered patio, but may not be fully enclosed unless the open space is an equipped interior fitness area or furnished meeting space not reservable by individual residents. (R)~~
- d. ~~Common open spaces with active uses used to meet these guidelines shall not be located within required buffer areas, if prohibited by critical area or shoreline regulations. (R)~~
- e. ~~Common open spaces shall provide at least three of the following amenities to accommodate a variety of ages and activities. Amenities include: (P)~~
 - i. ~~Site furnishings (benches, tables, bike racks)~~
 - ii. ~~Picnic or outdoor grilling areas~~
 - iii. ~~Patios, plazas, or courtyards~~
 - iv. ~~Tot lots or other children's play areas~~
 - v. ~~Enclosed pet areas that make up no more than fifty percent of the required common open space~~

vi. Community gardens accessible for use by residents

vii. Open lawn

viii. Play fields

ix. Sports courts, such as tennis or basketball courts, and pools that make up no more than fifty percent of the required common open space

x. Interior equipped fitness areas that make up no more than fifty percent of the required common open space

f. If common open spaces are located adjacent to a street right-of-way, landscaping should be used to provide a buffer between outdoor spaces and the street right-of-way. (P)

~~((4. Common outdoor spaces shall provide at least three of the following amenities to accommodate a variety of ages and activities. Amenities include: (P)~~

~~a. Site furnishings (benches, tables, bike racks).~~

~~b. Picnic areas.~~

~~c. Patios, plazas or courtyards.~~

~~d. Tot lots.~~

~~e. Gardens.~~

~~f. Open lawn.~~

~~g. Play fields.~~

~~h. Sports courts, such as tennis or basketball courts (no more than fifty percent of required outdoor common space), equipped interior fitness areas, or pools.))~~



[NOTE: Delete graphic above]



Basketball court provided in common outdoor area

[NOTE: Delete graphic above]

- ~~((5. Common outdoor spaces shall be easily visible and accessible to multifamily residents. (P))~~
- ~~6. Berms, low walls, fences, hedges and/or landscaping shall be used to define private ((outdoor)) open spaces such as yards, decks, terraces, and patios from each other and from the street right-of-way. (P)~~
- ~~7. Walls, hedges, and fences shall be used to define and ensure a sense of privacy in outdoor private spaces. The material or plantings should be a maximum of four feet (high and visually permeable, such as open rails, ironwork, or trellis treatment to encourage interaction between neighbors.) (P))~~
- ~~((8))4. Lighting shall be provided within ((outdoor)) open spaces to provide visual interest, as well as an additional security function. Lighting should not cause off-site glare. (R)~~
- ~~((9. If outdoor spaces are located adjacent to a street right-of-way, landscaping should be used to provide a buffer between outdoor spaces and the street right-of-way. (C))~~



Screening by wall and planting

[NOTE: Delete graphic above]

~~((10.—Common outdoor spaces with active uses used to meet these guidelines shall not be located within required buffer areas, if prohibited by critical area or shoreline regulations. (R))~~

~~((14))~~5. ~~((Outdoor))~~ Open spaces should not be located adjacent to dumpster enclosures, loading/service areas or other ~~((incompatible uses))~~ facility and/or utility enclosures. (C)

DRAFT



Workshop for Z24-105COMP

SHAPING SPOKANE – THE CITY OF SPOKANE COMPREHENSIVE PLAN

Document Date: June 5, 2024

On June 12 the Plan Commission is scheduled to discuss the first of six workshops on the [2023/2024 Comprehensive Plan Amendments](#). The 60-day public comment period for these applications began on June 10 and runs through August 9, 2024, during which time each of the proposals will be presented to you for your consideration. For detailed information on the Comprehensive Plan Amendment procedures, please see [Spokane Municipal Code \(SMC\) 17G.020](#).

This first proposal concerns the recommended Land Use Plan Map designation and zoning changes recommended by the South Logan TOD Plan, adopted by City Council on January 29, 2024 ([RES 2024-0015](#)). The Plan provides a framework and policies to create the envisioned future for the South Logan subarea. The adopted South Logan TOD Plan can be found here:

<https://static.spokanecity.org/documents/projects/south-logan-tod/south-logan-tod-final-plan-adopted-2024-01-29.pdf>

Also adopted January 29, 2024 through RES 2024-0015 was the [South Logan TOD Final Environmental Impact Statement \(FEIS\)](#). The FEIS reviewed the environmental impacts, mitigation measures, and potential impacts of the South Logan TOD Plan. The FEIS is serving as the environmental review for the proposed Land Use Plan Map designations and rezones. As such, the final adoption must not exceed the anticipated intensity of the South Logan subarea as envisioned in the Plan without additional environmental review(s).

As the second phase to the ongoing South Logan TOD Implementation, the proposed Land Use Plan Map and zoning designations reflect the 20-month planning process that led up to the adoption of the South Logan TOD Plan and FEIS.

Prior to the workshop, please visit the project webpage at the following link:

<https://my.spokanecity.org/projects/2023-2024-proposed-comprehensive-plan-amendments/south-logan-tod/>

Attachments:

- Existing Land Use Plan Map designations
- Proposed Land Use Plan Map designations
- Existing zoning designations
- Proposed zoning designations



Exhibit B1: Current Land Use Plan Map

Department of Planning & Economic Development



THIS IS NOT A LEGAL DOCUMENT
The information shown on this map is compiled from various sources and is subject to constant revision. Information shown on this map should not be used to determine the location of facilities in relationship to property lines, section lines, streets, etc.

Drawing Scale: 1:8,500

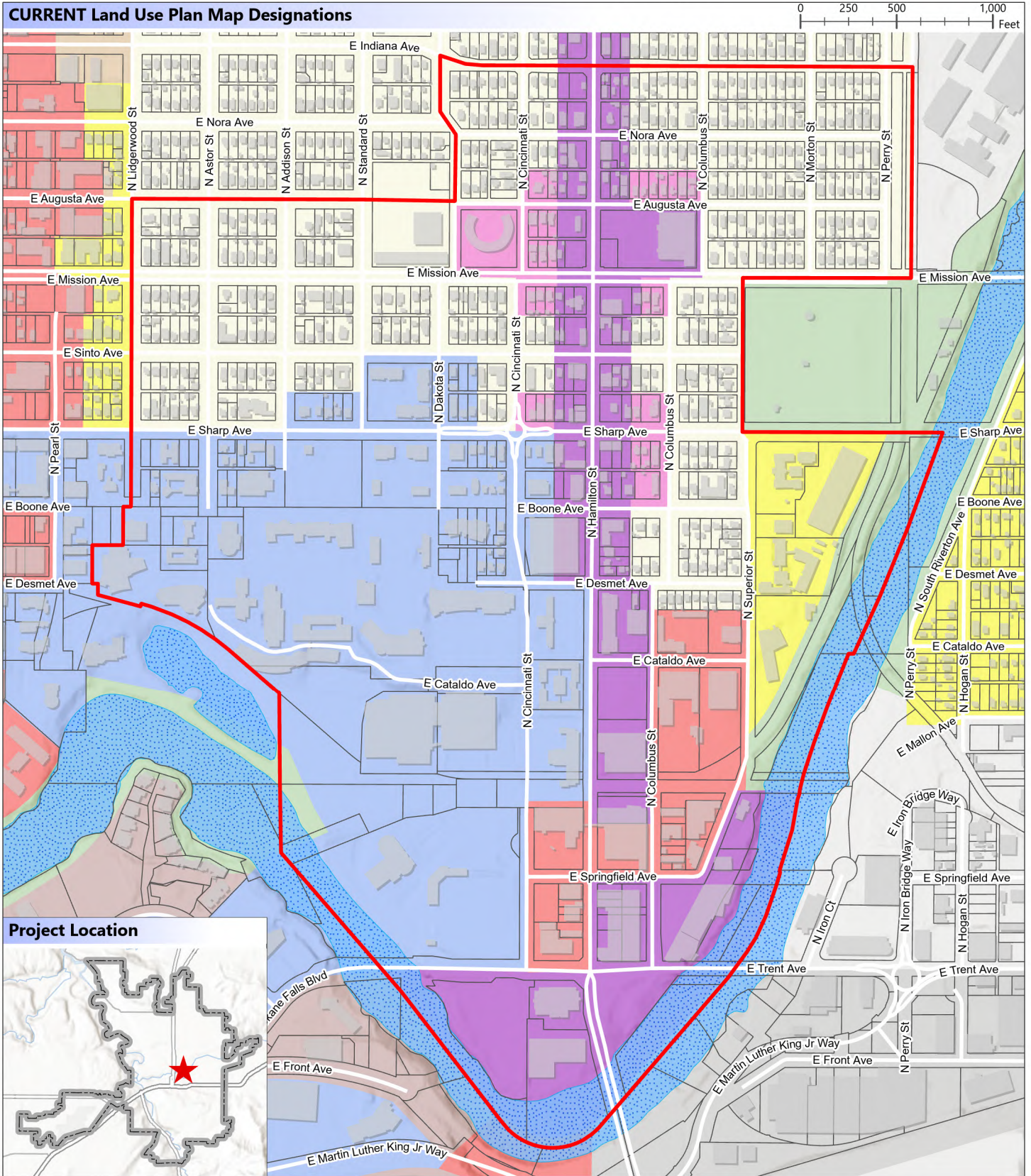

Project Location



- | | | | | | |
|--------------|-----------|-------------------------|---------------|--------------------|------------------|
| Project Area | Parcel | Conservation Open Space | Office | General Commercial | Heavy Industrial |
| Buildings | Waterbody | Residential Low | CC Core | Downtown | Institutional |
| | | Residential Moderate | CC Transition | Light Industrial | |



Exhibit B2: Proposed Land Use Plan Map



Department of Planning & Economic Development

Drawing Scale: 1:8,500

THIS IS NOT A LEGAL DOCUMENT
The information shown on this map is compiled from various sources and is subject to constant revision. Information shown on this map should not be used to determine the location of facilities in relationship to property lines, section lines, streets, etc.

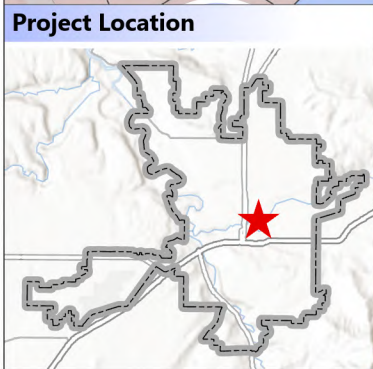
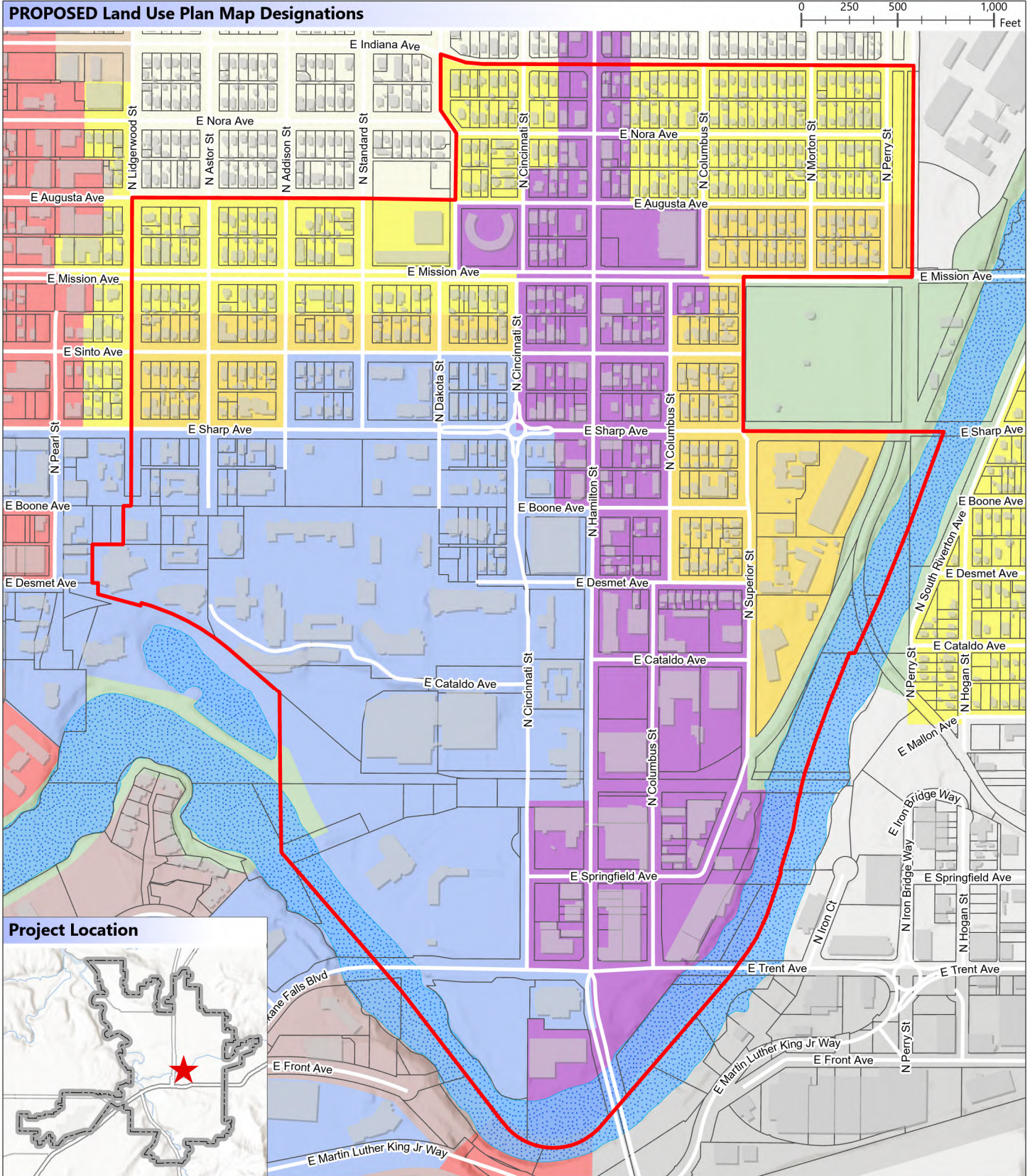

- Project Area
- Parcel
- CC Core
- Downtown
- Light Industrial
- Residential Low
- General Commercial
- Heavy Industrial
- Office
- Residential Moderate
- Buildings
- Waterbody
- Conservation Open Space
- Institutional
- Residential High



Exhibit C1: Current Zoning

Department of Planning & Economic Development



Drawing Scale: 1:8,500

THIS IS NOT A LEGAL DOCUMENT
The information shown on this map is compiled from various sources and is subject to constant revision. Information shown on this map should not be used to determine the location of facilities in relationship to property lines, section lines, streets, etc.

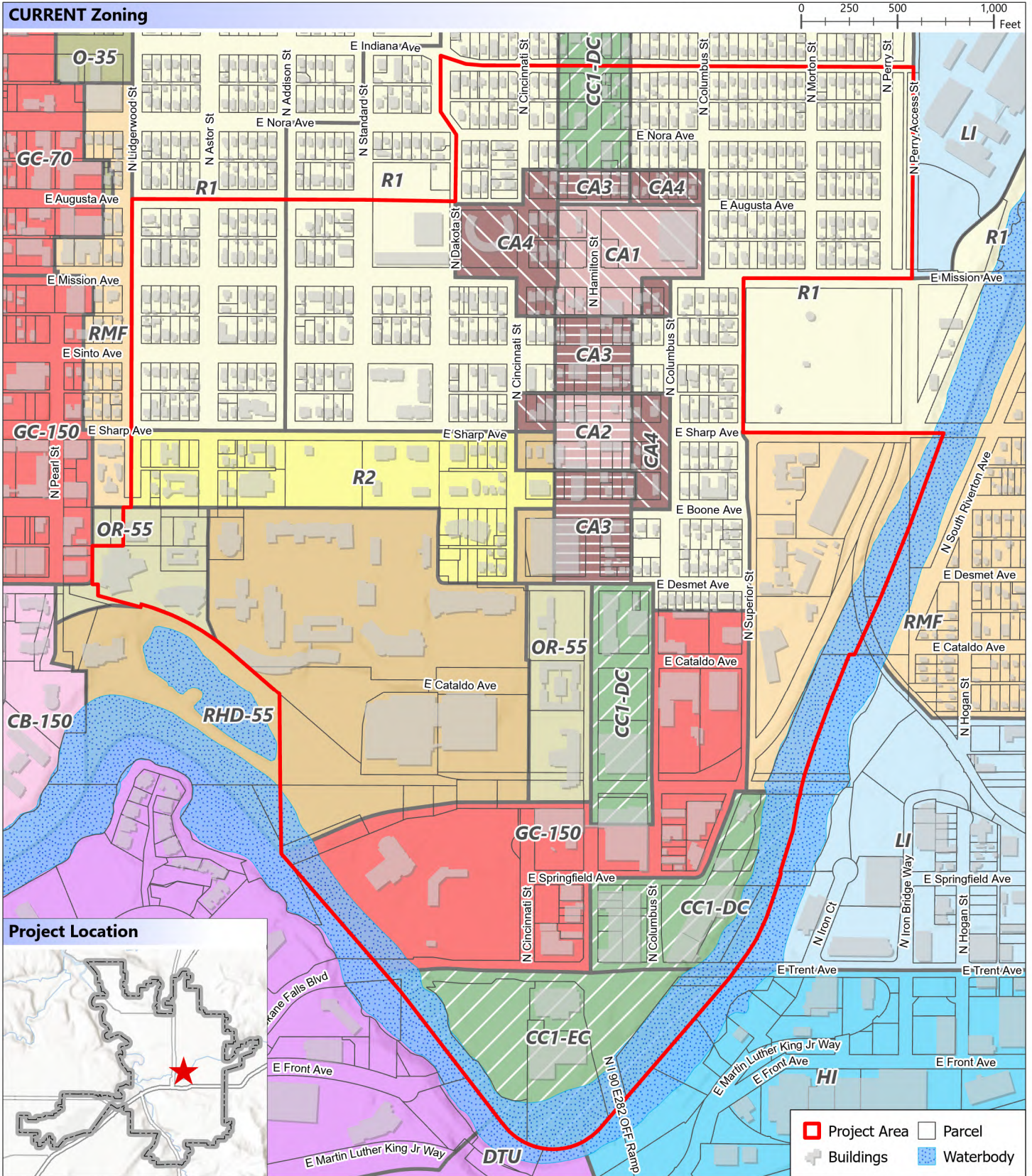

- | | | | | | |
|----------------------------|---------------------|--------------------|------------------|--------------------------|---------------|
| Center and Corridor Type 1 | Downtown University | Context Area 3 | Heavy Industrial | Office Retail | Residential 2 |
| Center and Corridor Type 2 | Context Area 1 | Context Area 4 | Light Industrial | Residential High Density | Residential 1 |
| Community Business | Context Area 2 | General Commercial | Office | Residential Multifamily | |



Exhibit C2: Proposed Zoning

Department of Planning & Economic Development



THIS IS NOT A LEGAL DOCUMENT
The information shown on this map is compiled from various sources and is subject to constant revision. Information shown on this map should not be used to determine the location of facilities in relationship to property lines, section lines, streets, etc.

Drawing Scale: 1:8,500

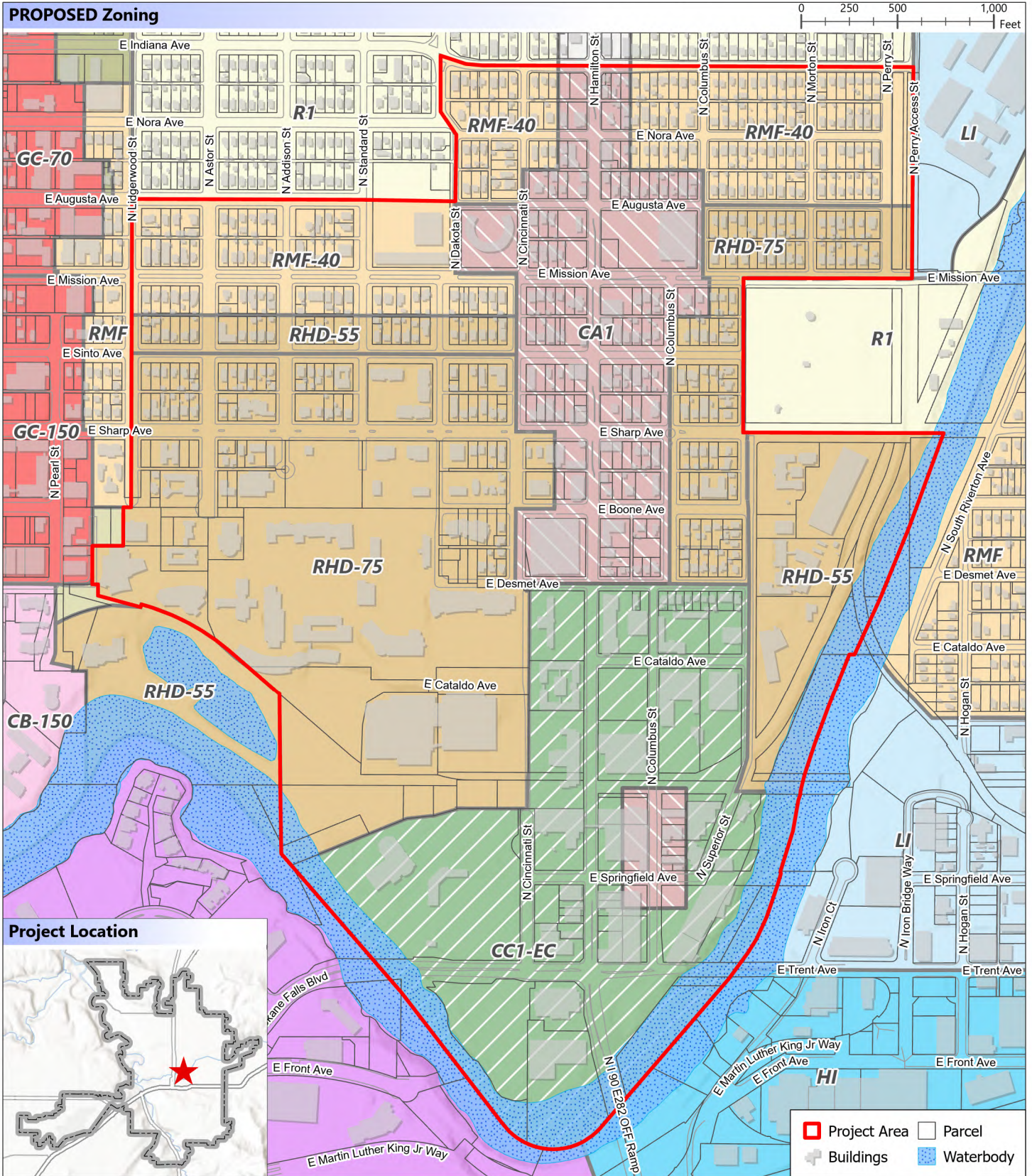

- | | | | | |
|----------------------------|---------------------|------------------|--------------------------|---------------|
| Center and Corridor Type 1 | Downtown University | Heavy Industrial | Office Retail | Residential 1 |
| Center and Corridor Type 2 | Context Area 1 | Light Industrial | Residential High Density | |
| Community Business | General Commercial | Office | Residential Multifamily | |